



**THE DATASHEET OF  
FN2020B-6-06**



## DS91M047 125 MHz Quad M-LVDS Line Driver

Check for Samples: [DS91M047](#)

### FEATURES

- DC - 125 MHz / 250 Mbps Low Jitter, Low Skew, Low Power Operation
- Conforms to TIA/EIA-899 M-LVDS Standard
- Controlled Transition Times (2 ns typ) Minimize Reflections
- 8 kV ESD on M-LVDS Pins Protects Adjoining Components
- Flow-Through Pinout Simplifies PCB Layout
- Industrial Operating Temperature Range (–40°C to +85°C)
- Available in a Space Saving SOIC-16 Package

### APPLICATIONS

- Multidrop / Multipoint Clock and Data Distribution
- High-Speed, Low Power, Short-Reach Alternative to TIA/EIA-485/422
- Clock Distribution in AdvancedTCA (ATCA) and MicroTCA (μTCA, uTCA) Backplanes

### DESCRIPTION

The DS91M047 is a high-speed quad M-LVDS line driver designed for driving clock or data signals to up to four multipoint networks.

M-LVDS (Multipoint LVDS) is a new family of bus interface devices based on LVDS technology specifically designed for multipoint and multidrop cable and backplane applications. It differs from standard LVDS in providing increased drive current to handle double terminations that are required in multipoint applications. Controlled transition times minimize reflections that are common in multipoint configurations due to unterminated stubs.

The DS91M047 accepts LVTTTL/LVCMOS input levels and translates them to M-LVDS signal levels with transition times of greater than 1 ns. The device provides the DE and  $\overline{DE}$  inputs that are ANDed together and control the TRI-STATE outputs. The DE and  $\overline{DE}$  inputs are common to all four drivers.

The DS91M047 has a flow-through pinout for easy PCB layout. The DS91M047 provides a new alternative for high speed multipoint interface applications. It is packaged in a space saving SOIC-16 package.

### TYPICAL APPLICATION

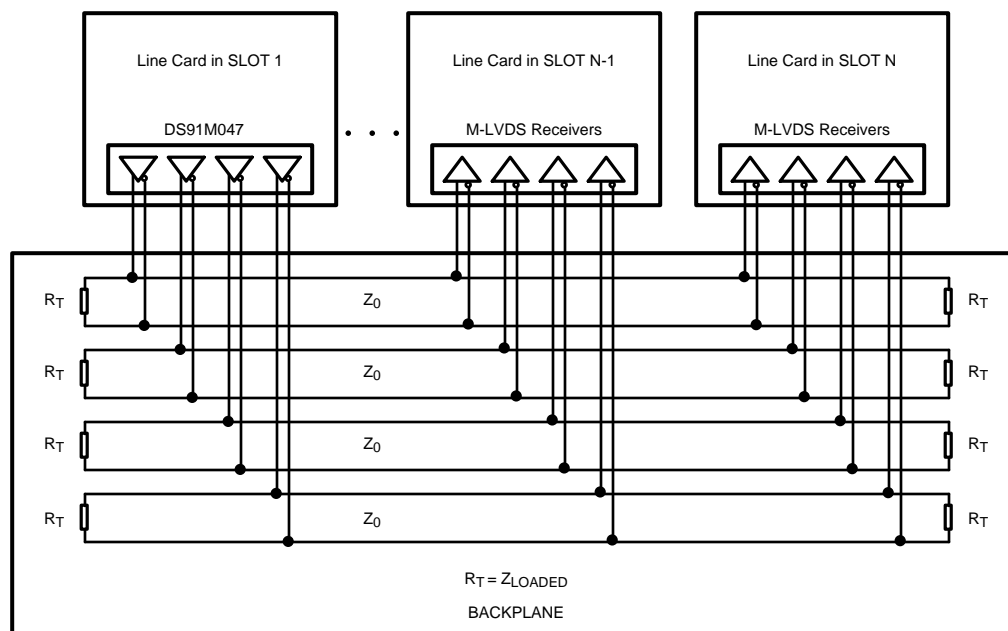

Please be aware that an important notice concerning availability, standard warranty, and use in critical applications of Texas Instruments semiconductor products and disclaimers thereto appears at the end of this data sheet.

All trademarks are the property of their respective owners.

**Connection Diagrams**

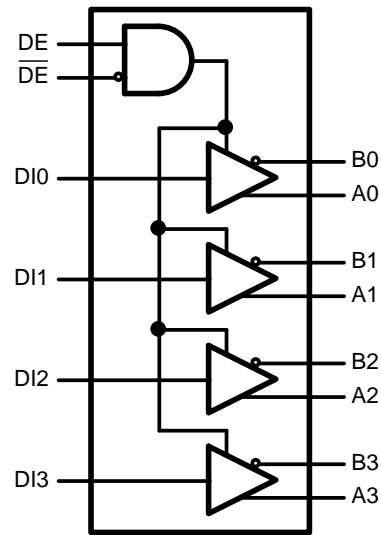
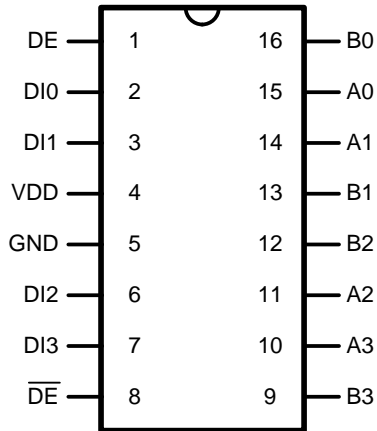

**PIN DESCRIPTIONS**

Pin No.	Name	Description
2, 3, 6, 7	DI	Driver input pin, LVCMOS compatible.
10, 11, 14, 15	A	Non-inverting driver output pin, M-LVDS levels.
9, 12, 13, 16	B	Inverting driver output pin, M-LVDS levels.
1	DE	Driver enable pin: When DE is low, the driver is disabled. When DE is high and DE-bar is low or open, the driver is enabled. If both DE and DE-bar are open circuit, then the driver is disabled.
8	DE-bar	Driver enable pin: When DE-bar is high, the driver is disabled. When DE-bar is low or open and DE is high, the driver is enabled. If both DE and DE-bar are open circuit, then the driver is disabled.
4	V <sub>DD</sub>	Power supply pin, +3.3V ± 0.3V
5	GND	Ground pin

**TRUTH TABLE**

Enables		Input	Outputs	
DE	DE-bar		A	B
H	L	L	L	H
		H	H	L
All other combinations of ENABLE inputs		X	Z	Z



These devices have limited built-in ESD protection. The leads should be shorted together or the device placed in conductive foam during storage or handling to prevent electrostatic damage to the MOS gates.

## ABSOLUTE MAXIMUM RATINGS<sup>(1)(2)</sup>

Power Supply Voltage		-0.3V to +4V
LVCMOS Input Voltage		-0.3V to ( $V_{DD} + 0.3V$ )
M-LVDS Output Voltage		-1.9V to +5.5V
M-LVDS Output Short Circuit Current Duration		Continuous
Junction Temperature		+140°C
Storage Temperature Range		-65°C to +150°C
Lead Temperature Range	Soldering (4 sec.)	+260°C
Maximum Package Power Dissipation @ +25°C	D Package	2.21W
	Derate D Package	19.2 mW/°C above +25°C
Package Thermal Resistance (4-Layer, 2 oz. Cu, JEDEC)	$\theta_{JA}$	+52°C/W
	$\theta_{JC}$	+19°C/W
ESD Susceptibility	HBM	≥8 kV
	MM	≥250V
	CDM	≥1250V

- (1) Absolute Maximum Ratings indicate limits beyond which damage to the device may occur, including inoperability and degradation of device reliability and/or performance. Functional operation of the device and/or non-degradation at the Absolute Maximum Ratings or other conditions beyond those indicated in the is not implied. The Recommended Operating Conditions indicate conditions at which the device is functional and the device should not be operated beyond such conditions.
- (2) If Military/Aerospace specified devices are required, please contact the Texas Instruments Sales Office/Distributors for availability and specifications.

## RECOMMENDED OPERATING CONDITIONS

	Min	Typ	Max	Units
Supply Voltage ( $V_{DD}$ )	+3.0	+3.3	+3.6	V
Voltage at Any Bus Terminal (Separate or Common-Mode)	-1.4		+3.8	V
High Level Input Voltage ( $V_{IH}$ )	2.0		$V_{DD}$	V
Low Level Input Voltage ( $V_{IL}$ )	0		0.8	V
Operating Free Air Temperature ( $T_A$ )	-40	+25	+85	°C

**DC ELECTRICAL CHARACTERISTICS**<sup>(1)(2)(3)(4)</sup>

Over supply voltage and operating temperature ranges, unless otherwise specified.

Symbol	Parameter	Conditions	Min	Typ	Max	Units
<b>LVC MOS DC Specifications</b>						
$V_{IH}$	High-Level Input Voltage		2.0		$V_{DD}$	V
$V_{IL}$	Low-Level Input Voltage		GND		0.8	V
$I_{IH}$	High-Level Input Current	$V_{IH} = 3.6V$	-15	$\pm 1$	15	$\mu A$
$I_{IL}$	Low-Level Input Current	$V_{IL} = 0V$	-15	$\pm 1$	15	$\mu A$
$V_{CL}$	Input Clamp Voltage	$I_{IN} = -18\text{ mA}$	-1.5			V
<b>M-LVDS DC Specifications</b>						
$ V_{AB} $	Differential Output Voltage Magnitude	$R_L = 50\Omega$ , $C_L = 5\text{ pF}$ See <a href="#">Figure 1</a> and <a href="#">Figure 3</a>	480		650	mV
$\Delta V_{AB}$	Change in Differential Output Voltage Magnitude Between Logic States		-50		50	mV
$V_{OS(SS)}$	Steady-State Common-Mode Output Voltage	$R_L = 50\Omega$ See <a href="#">Figure 1</a> and <a href="#">Figure 2</a>	0.30	1.6	2.10	V
$ \Delta V_{OS(SS)} $	Change in Steady-State Common-Mode Output Voltage Between Logic States		0		50	mV
$V_{A(OC)}$	Maximum Steady-State Open-Circuit Output Voltage	See <a href="#">Figure 4</a>	0		2.4	V
$V_{B(OC)}$	Maximum Steady-State Open-Circuit Output Voltage		0		2.4	V
$V_{P(H)}$	Voltage Overshoot, Low-to-High Level Output <sup>(5)</sup>	$R_L = 50\Omega$ , $C_L = 5\text{ pF}$ $C_D = 0.5\text{ pF}$ , see <a href="#">Figure 6</a> and <a href="#">Figure 7</a>			$1.2V_{SS}$	V
$V_{P(L)}$	Voltage Overshoot, High-to-Low Level Output <sup>(5)</sup>		$-0.2V_{SS}$			V
$I_{OS}$	Output Short-Circuit Current <sup>(6)</sup>	See <a href="#">Figure 5</a>	-43		43	mA
$I_A$	Driver High-Impedance Output Current	$V_A = 3.8V$ , $V_B = 1.2V$	0		32	$\mu A$
		$V_A = 0V$ or $2.4V$ , $V_B = 1.2V$	-20		20	$\mu A$
		$V_A = -1.4V$ , $V_B = 1.2V$	-32		0	$\mu A$
$I_B$	Driver High-Impedance Output Current	$V_A = 3.8V$ , $V_B = 1.2V$	0		32	$\mu A$
		$V_A = 0V$ or $2.4V$ , $V_B = 1.2V$	-20		20	$\mu A$
		$V_A = -1.4V$ , $V_B = 1.2V$	-32		0	$\mu A$
$I_{AB}$	Driver High-Impedance Output Differential Current ( $I_A - I_B$ )	$V_A = V_B$ , $-1.4V \leq V \leq 3.8V$	-4		4	$\mu A$
$I_{A(OFF)}$	Driver High-Impedance Output Power-Off Current	$V_A = 3.8V$ , $V_B = 1.2V$ $DE = 0V$ $0V \leq V_{DD} \leq 1.5V$	0		32	$\mu A$
		$V_A = 0V$ or $2.4V$ , $V_B = 1.2V$ $DE = 0V$ $0V \leq V_{DD} \leq 1.5V$	-20		20	$\mu A$
		$V_A = -1.4V$ , $V_B = 1.2V$ $DE = 0V$ $0V \leq V_{DD} \leq 1.5V$	-32		0	$\mu A$
$I_{B(OFF)}$	Driver High-Impedance Output Power-Off Current	$V_A = 3.8V$ , $V_B = 1.2V$ $DE = 0V$ $0V \leq V_{DD} \leq 1.5V$	0		32	$\mu A$
		$V_A = 0V$ or $2.4V$ , $V_B = 1.2V$ $DE = 0V$ $0V \leq V_{DD} \leq 1.5V$	-20		20	$\mu A$
		$V_A = -1.4V$ , $V_B = 1.2V$ $DE = 0V$ $0V \leq V_{DD} \leq 1.5V$	-32		0	$\mu A$

- (1) The [Electrical Characteristics](#) tables list ensured specifications under the listed [Recommended Operating Conditions](#) except as otherwise modified or specified by the Electrical Characteristics Conditions and/or Notes. Typical specifications are estimations only and are not ensured.
- (2) Current into device pins is defined as positive. Current out of device pins is defined as negative. All voltages are referenced to ground except  $V_{OD}$  and  $\Delta V_{OD}$ .
- (3) Typical values represent most likely parametric norms for  $V_{DD} = +3.3V$  and  $T_A = +25^\circ C$ , and at the [Recommended Operating Conditions](#) at the time of product characterization and are not ensured.
- (4)  $C_L$  includes fixture capacitance and  $C_D$  includes probe capacitance.
- (5) Specification is specified by characterization and is not tested in production.
- (6) Output short circuit current ( $I_{OS}$ ) is specified as magnitude only, minus sign indicates direction only.

## DC ELECTRICAL CHARACTERISTICS<sup>(1)(2)(3)(4)</sup> (continued)

Over supply voltage and operating temperature ranges, unless otherwise specified.

Symbol	Parameter	Conditions	Min	Typ	Max	Units
$I_{AB(OFF)}$	Driver High-Impedance Output Power-Off Current ( $I_{A(OFF)} - I_{B(OFF)}$ )	$V_A = V_B, -1.4V \leq V \leq 3.8V$ $DE = 0V$ $0V \leq V_{DD} \leq 1.5V$	-4		4	$\mu A$
$C_A$	Driver Output Capacitance	$V_{DD} = 0V$		7.8		pF
$C_B$	Driver Output Capacitance			7.8		pF
$C_{AB}$	Driver Output Differential Capacitance			3		pF
$C_{A/B}$	Driver Output Capacitance Balance ( $C_A/C_B$ )			1		
$I_{CC}$	Power Supply Current	$R_L = 50\Omega$ (All Outputs) $DI = V_{DD}$ or GND (All Inputs) $DE = V_{DD}, \overline{DE} = GND$ $f = 125\text{ MHz}$		65	75	mA
$I_{CCZ}$	TRI-STATE Power Supply Current	$R_L = 50\Omega$ (All Outputs) $DI = V_{DD}$ or GND (All Inputs) $DE = GND, \overline{DE} = V_{DD}$		19	24	mA

## SWITCHING CHARACTERISTICS<sup>(1)(2)(3)</sup>

Over supply voltage and operating temperature ranges, unless otherwise specified.

Symbol	Parameter	Conditions	Min	Typ	Max	Units
$t_{PHL}$	Differential Propagation Delay High to Low	$R_L = 50\Omega$ $C_L = 5\text{ pF},$ $C_D = 0.5\text{ pF}$ See <a href="#">Figure 6</a> and <a href="#">Figure 7</a>	1.5	3.1	5.0	ns
$t_{PLH}$	Differential Propagation Delay Low to High		1.5	3.1	5.0	ns
$t_{SKD1}$	Differential Pulse Skew $ t_{PHL} - t_{PLH} $ <sup>(4)(5)</sup>		0	70	140	ps
$t_{SKD2}$	Channel-to-Channel Skew <sup>(4)(6)</sup>		0	70	200	ps
$t_{SKD3}$	Differential Part-to-Part Skew <sup>(4)(7)</sup> (Constant $T_A$ and $V_{DD}$ )		0	0.8	1.5	ns
$t_{SKD4}$	Differential Part-to-Part Skew <sup>(8)</sup>		0		3.5	ns
$t_{TLH}$	Rise Time <sup>(4)</sup>		1.1	2.0	3.0	ns
$t_{THL}$	Fall Time <sup>(4)</sup>		1.1	2.0	3.0	ns
$t_{PHZ}$	Disable Time High to Z	$R_L = 50\Omega$ $C_L = 5\text{ pF},$ $C_D = 0.5\text{ pF}$ See <a href="#">Figure 8</a> and <a href="#">Figure 9</a>		7	12.5	ns
$t_{PLZ}$	Disable Time Low to Z			7	12.5	ns
$t_{PZH}$	Enable Time Z to High			7	12.5	ns
$t_{PZL}$	Enable Time Z to Low			7	12.5	ns
$f_{MAX}$	Maximum Operating Frequency	See <sup>(4)</sup>	125			MHz

- (1) The [Electrical Characteristics](#) list ensured specifications under the listed [Recommended Operating Conditions](#) except as otherwise modified or specified by the Electrical Characteristics Conditions and/or Notes. Typical specifications are estimations only and are not ensured.
- (2) Typical values represent most likely parametric norms for  $V_{DD} = +3.3V$  and  $T_A = +25^\circ C$ , and at the [Recommended Operating Conditions](#) at the time of product characterization and are not ensured.
- (3)  $C_L$  includes fixture capacitance and  $C_D$  includes probe capacitance.
- (4) Specification is specified by characterization and is not tested in production.
- (5)  $t_{SKD1}, |t_{PLHD} - t_{PHLD}|$ , Pulse Skew, is the magnitude difference in differential propagation delay time between the positive going edge and the negative going edge of the same channel.
- (6)  $t_{SKD2}$ , Channel-to-Channel Skew, is the difference in propagation delay ( $t_{PLHD}$  or  $t_{PHLD}$ ) among all output channels.
- (7)  $t_{SKD3}$ , Part-to-Part Skew, is defined as the difference between the minimum and maximum differential propagation delays. This specification applies to devices at the same  $V_{DD}$  and within  $5^\circ C$  of each other within the operating temperature range.
- (8)  $t_{SKD4}$ , Part-to-Part Skew, is the differential channel-to-channel skew of any event between devices. This specification applies to devices over recommended operating temperature and voltage ranges, and across process distribution.  $t_{SKD4}$  is defined as  $|Max - Min|$  differential propagation delay.

**PARAMETER MEASUREMENT INFORMATION**

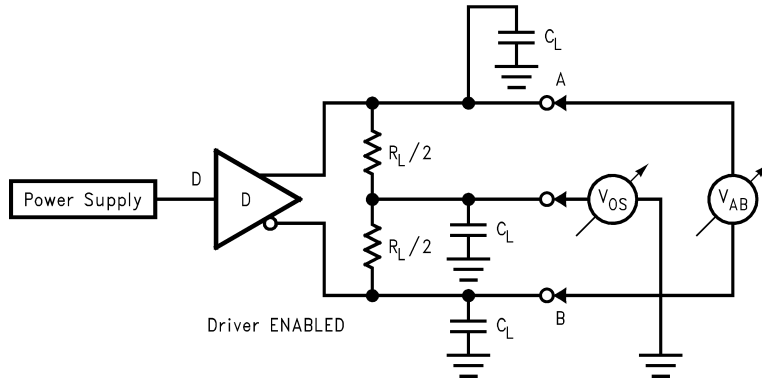

**Figure 1. Differential Driver Test Circuit**

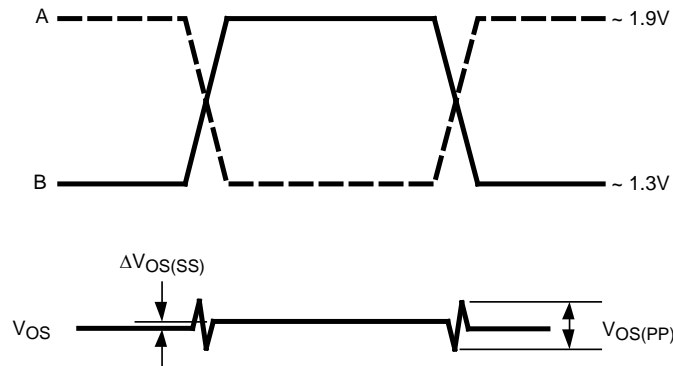

**Figure 2. Differential Driver Waveforms**

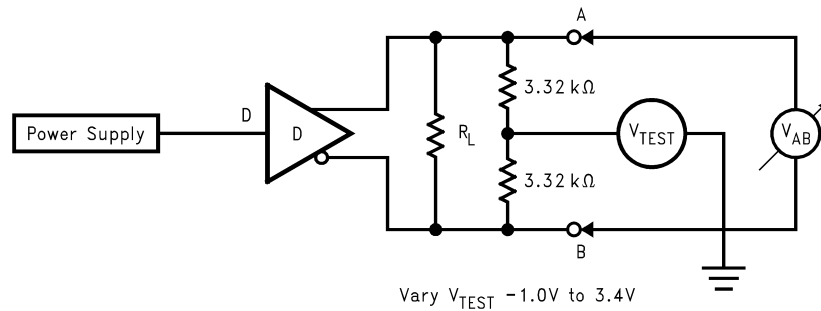

**Figure 3. Differential Driver Full Load Test Circuit**

PARAMETER MEASUREMENT INFORMATION (continued)

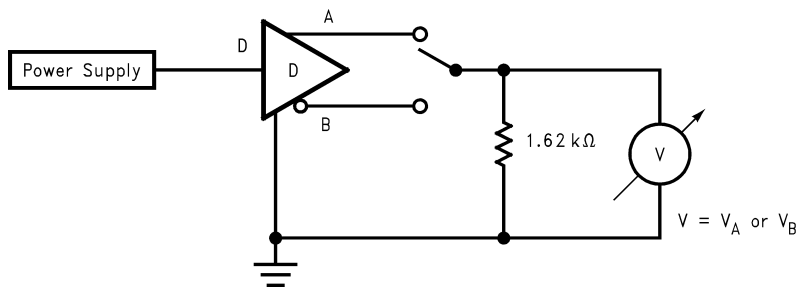

Figure 4. Differential Driver DC Open Test Circuit

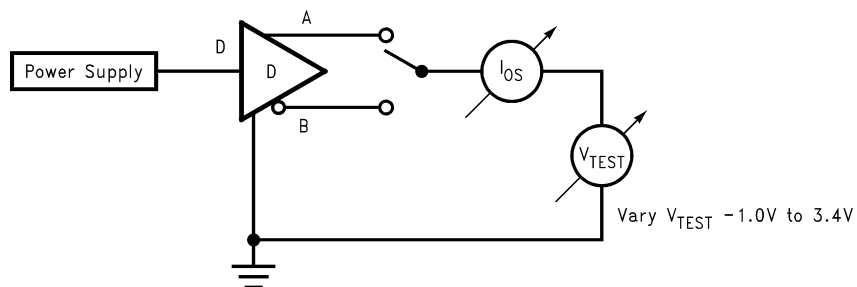

Figure 5. Differential Driver Short-Circuit Test Circuit

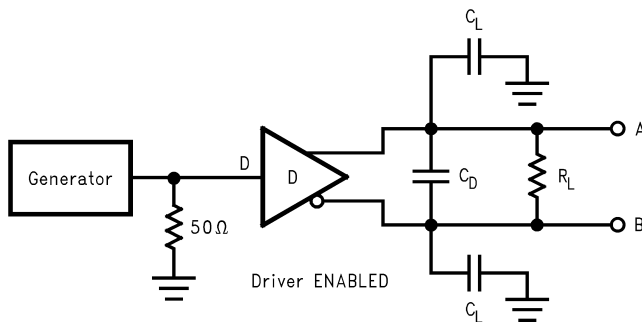
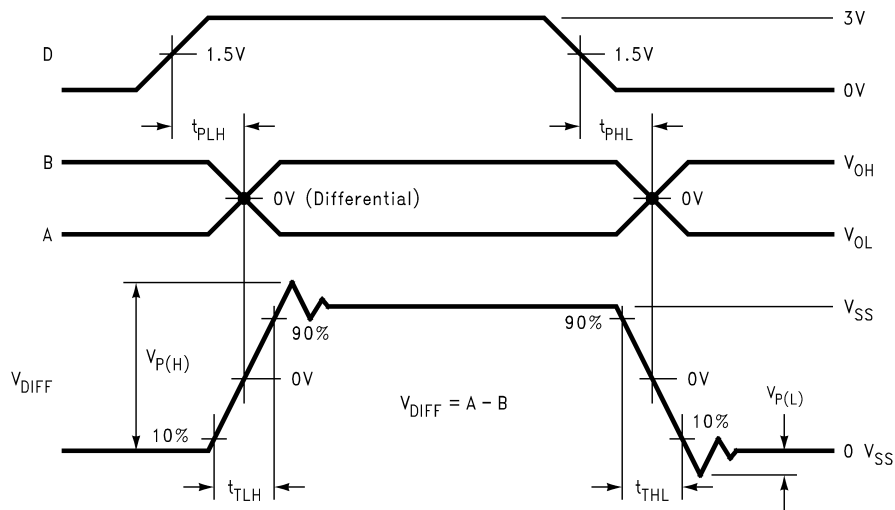
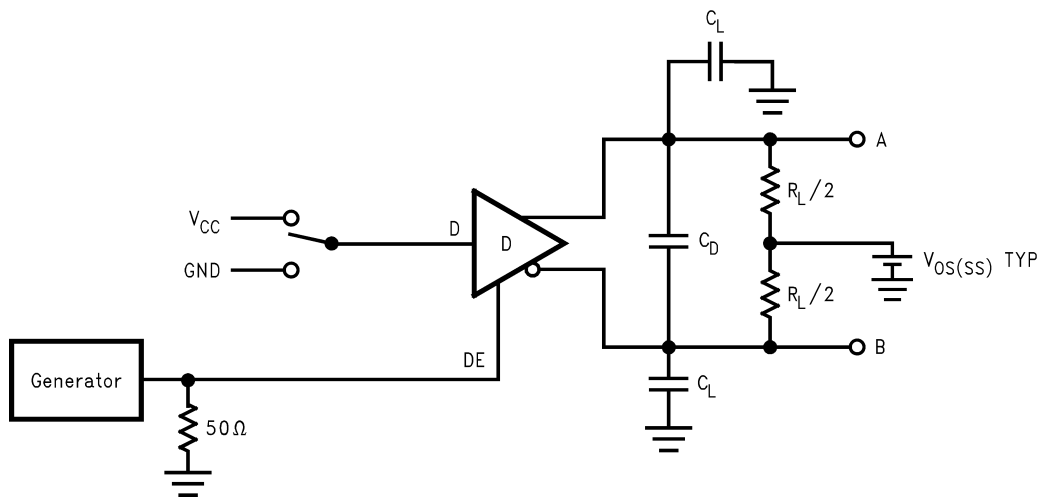

Figure 6. Driver Propagation Delay and Transition Time Test Circuit

**PARAMETER MEASUREMENT INFORMATION (continued)**



**Figure 7. Driver Propagation Delay and Transition Time Waveforms**



**Figure 8. Driver TRI-STATE Delay Test Circuit**

PARAMETER MEASUREMENT INFORMATION (continued)

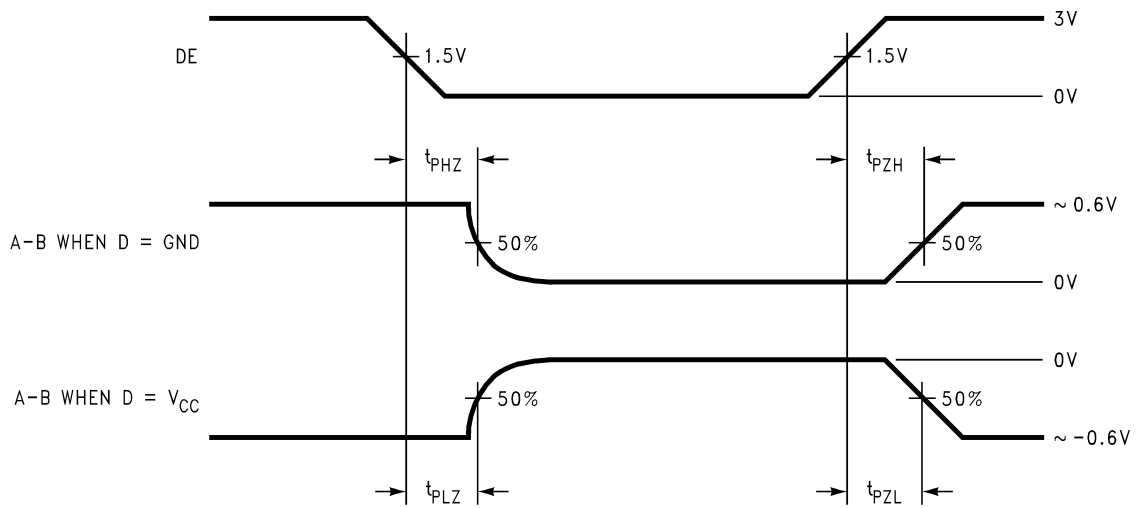

Figure 9. Driver TRI-STATE Delay Waveforms

**TYPICAL PERFORMANCE CHARACTERISTICS**

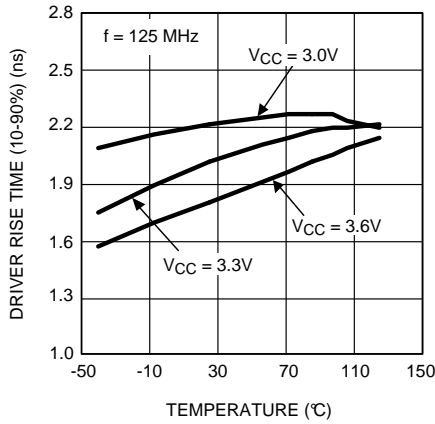

Figure 10. Driver Rise Time as a Function of Temperature

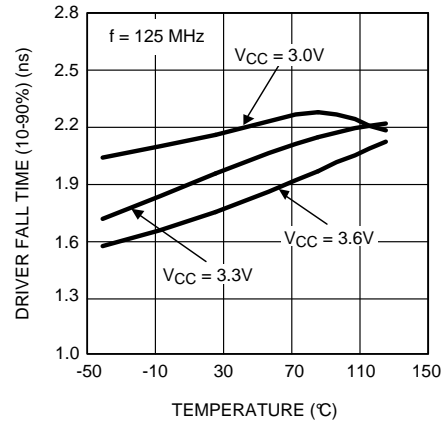

Figure 11. Driver Fall Time as a Function of Temperature

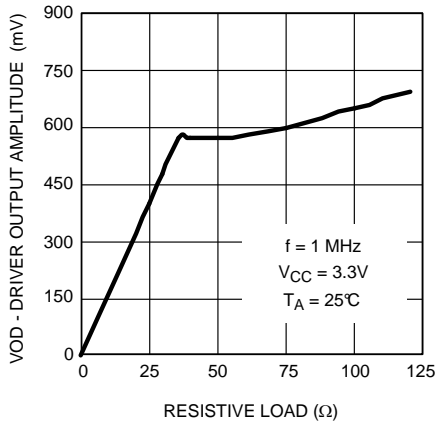

Figure 12. Driver Output Signal Amplitude as a Function of Resistive Load

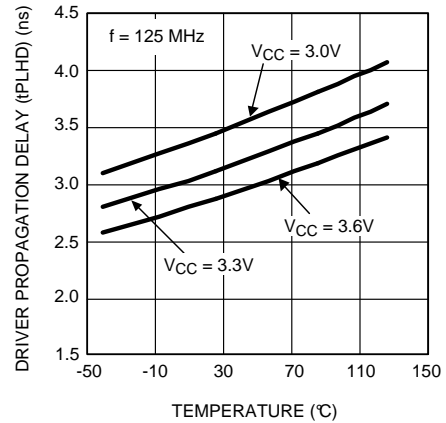

Figure 13. Driver Propagation Delay (tPLHD) as a Function of Temperature

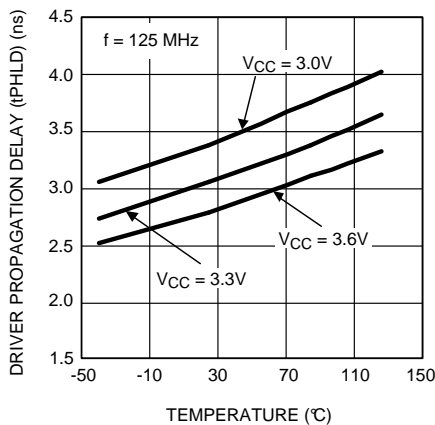

Figure 14. Driver Propagation Delay (tPHLD) as a Function of Temperature

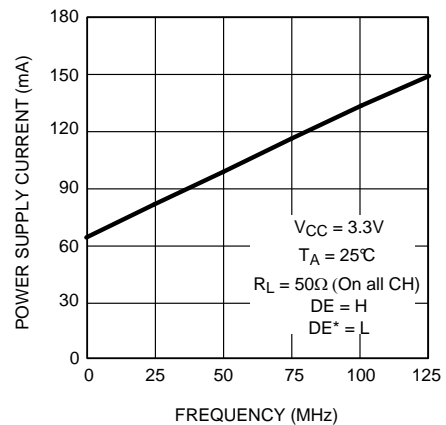



Figure 15. Driver Power Supply Current as a Function of Frequency

---

**REVISION HISTORY**

<b>Changes from Revision D (April 2013) to Revision E</b>	<b>Page</b>
<hr/> <ul style="list-style-type: none"><li>• Changed layout of National Data Sheet to TI format .....</li></ul>	<hr/> <a href="#">10</a>

**PACKAGING INFORMATION**

Orderable Device	Status (1)	Package Type	Package Drawing	Pins	Package Qty	Eco Plan (2)	Lead finish/ Ball material (6)	MSL Peak Temp (3)	Op Temp (°C)	Device Marking (4/5)	Samples
DS91M047TMA/NOPB	ACTIVE	SOIC	D	16	48	RoHS & Green	SN	Level-1-260C-UNLIM	-40 to 85	DS91M047 TMA	
DS91M047TMAX/NOPB	ACTIVE	SOIC	D	16	2500	RoHS & Green	SN	Level-1-260C-UNLIM	-40 to 85	DS91M047 TMA	

(1) The marketing status values are defined as follows:

**ACTIVE:** Product device recommended for new designs.

**LIFEBUY:** TI has announced that the device will be discontinued, and a lifetime-buy period is in effect.

**NRND:** Not recommended for new designs. Device is in production to support existing customers, but TI does not recommend using this part in a new design.

**PREVIEW:** Device has been announced but is not in production. Samples may or may not be available.

**OBsolete:** TI has discontinued the production of the device.

(2) **RoHS:** TI defines "RoHS" to mean semiconductor products that are compliant with the current EU RoHS requirements for all 10 RoHS substances, including the requirement that RoHS substance do not exceed 0.1% by weight in homogeneous materials. Where designed to be soldered at high temperatures, "RoHS" products are suitable for use in specified lead-free processes. TI may reference these types of products as "Pb-Free".

**RoHS Exempt:** TI defines "RoHS Exempt" to mean products that contain lead but are compliant with EU RoHS pursuant to a specific EU RoHS exemption.

**Green:** TI defines "Green" to mean the content of Chlorine (Cl) and Bromine (Br) based flame retardants meet JS709B low halogen requirements of <=1000ppm threshold. Antimony trioxide based flame retardants must also meet the <=1000ppm threshold requirement.

(3) MSL, Peak Temp. - The Moisture Sensitivity Level rating according to the JEDEC industry standard classifications, and peak solder temperature.

(4) There may be additional marking, which relates to the logo, the lot trace code information, or the environmental category on the device.

(5) Multiple Device Markings will be inside parentheses. Only one Device Marking contained in parentheses and separated by a "~" will appear on a device. If a line is indented then it is a continuation of the previous line and the two combined represent the entire Device Marking for that device.

(6) Lead finish/Ball material - Orderable Devices may have multiple material finish options. Finish options are separated by a vertical ruled line. Lead finish/Ball material values may wrap to two lines if the finish value exceeds the maximum column width.

**Important Information and Disclaimer:**The information provided on this page represents TI's knowledge and belief as of the date that it is provided. TI bases its knowledge and belief on information provided by third parties, and makes no representation or warranty as to the accuracy of such information. Efforts are underway to better integrate information from third parties. TI has taken and continues to take reasonable steps to provide representative and accurate information but may not have conducted destructive testing or chemical analysis on incoming materials and chemicals. TI and TI suppliers consider certain information to be proprietary, and thus CAS numbers and other limited information may not be available for release.

In no event shall TI's liability arising out of such information exceed the total purchase price of the TI part(s) at issue in this document sold by TI to Customer on an annual basis.



**TAPE AND REEL INFORMATION**

**QUADRANT ASSIGNMENTS FOR PIN 1 ORIENTATION IN TAPE**



\*All dimensions are nominal

Device	Package Type	Package Drawing	Pins	SPQ	Reel Diameter (mm)	Reel Width W1 (mm)	A0 (mm)	B0 (mm)	K0 (mm)	P1 (mm)	W (mm)	Pin1 Quadrant
DS91M047TMAX/NOPB	SOIC	D	16	2500	330.0	16.4	6.5	10.3	2.3	8.0	16.0	Q1

**TAPE AND REEL BOX DIMENSIONS**

\*All dimensions are nominal

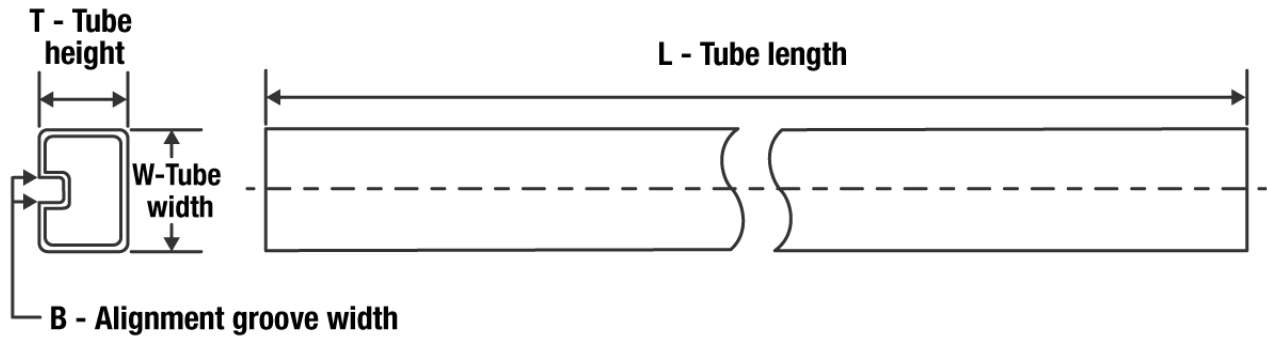
Device	Package Type	Package Drawing	Pins	SPQ	Length (mm)	Width (mm)	Height (mm)
DS91M047TMAX/NOPB	SOIC	D	16	2500	367.0	367.0	35.0

**TUBE**

\*All dimensions are nominal

Device	Package Name	Package Type	Pins	SPQ	L (mm)	W (mm)	T (μm)	B (mm)
DS91M047TMA/NOPB	D	SOIC	16	48	495	8	4064	3.05

D (R-PDSO-G16)

PLASTIC SMALL OUTLINE

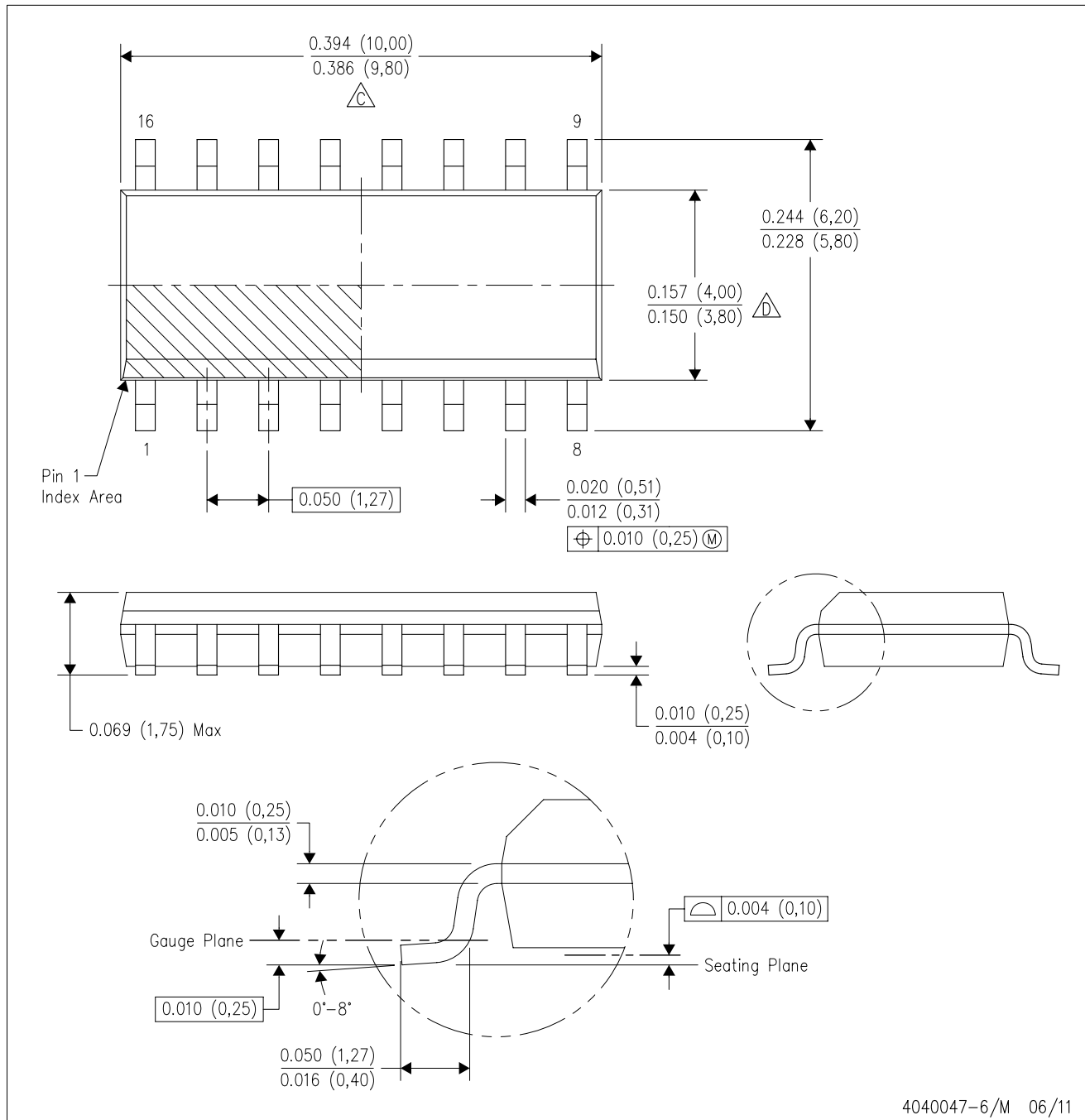

- NOTES:
- A. All linear dimensions are in inches (millimeters).
  - B. This drawing is subject to change without notice.
  - C. Body length does not include mold flash, protrusions, or gate burrs. Mold flash, protrusions, or gate burrs shall not exceed 0.006 (0,15) each side.
  - D. Body width does not include interlead flash. Interlead flash shall not exceed 0.017 (0,43) each side.
  - E. Reference JEDEC MS-012 variation AC.

## IMPORTANT NOTICE AND DISCLAIMER

TI PROVIDES TECHNICAL AND RELIABILITY DATA (INCLUDING DATA SHEETS), DESIGN RESOURCES (INCLUDING REFERENCE DESIGNS), APPLICATION OR OTHER DESIGN ADVICE, WEB TOOLS, SAFETY INFORMATION, AND OTHER RESOURCES "AS IS" AND WITH ALL FAULTS, AND DISCLAIMS ALL WARRANTIES, EXPRESS AND IMPLIED, INCLUDING WITHOUT LIMITATION ANY IMPLIED WARRANTIES OF MERCHANTABILITY, FITNESS FOR A PARTICULAR PURPOSE OR NON-INFRINGEMENT OF THIRD PARTY INTELLECTUAL PROPERTY RIGHTS.

These resources are intended for skilled developers designing with TI products. You are solely responsible for (1) selecting the appropriate TI products for your application, (2) designing, validating and testing your application, and (3) ensuring your application meets applicable standards, and any other safety, security, regulatory or other requirements.

These resources are subject to change without notice. TI grants you permission to use these resources only for development of an application that uses the TI products described in the resource. Other reproduction and display of these resources is prohibited. No license is granted to any other TI intellectual property right or to any third party intellectual property right. TI disclaims responsibility for, and you will fully indemnify TI and its representatives against, any claims, damages, costs, losses, and liabilities arising out of your use of these resources.



TI's products are provided subject to [TI's Terms of Sale](#) or other applicable terms available either on [ti.com](http://ti.com) or provided in conjunction with such TI products. TI's provision of these resources does not expand or otherwise alter TI's applicable warranties or warranty disclaimers for TI products.

TI objects to and rejects any additional or different terms you may have proposed.

Mailing Address: Texas Instruments, Post Office Box 655303, Dallas, Texas 75265  
Copyright © 2022, Texas Instruments Incorporated

## Looking for pricing, stock, or lifecycle information?

Click below to explore more details on WIN SOURCE:

-  [View FN2020B-6-06 on WIN SOURCE](#)
-  [Schaffner EMC Inc. Information](#)

## Optimize Your Supply Chain with WIN SOURCE Solutions

-  Global Sourcing Solution
-  Obsolete Management
-  Cost Control Management
-  Shortage Management
-  Alternative Solution
-  Excess Inventory Management