



**THE DATASHEET OF
FC1-10-01-T-K-TR**



FLAT FLEXIBLE CABLE (FCC) JUMPER & SOCKET

(1.00 mm) .0394" PITCH • FJ/ZF1/FC1 SERIES

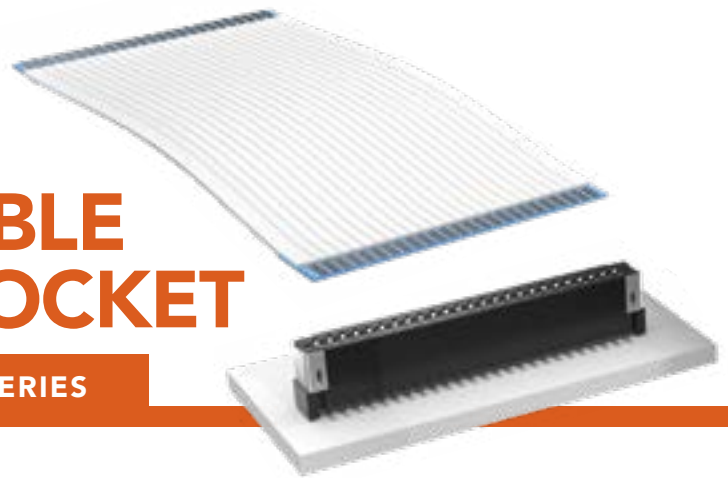

FJ

Mates:
FC1, ZF1

ZF1/FC1

Mates:
FJ

SPECIFICATIONS

FJ

Conductor:
Tin Plated Copper
Conductor Resistance:
300 Ω/km max
Operating Temp Range:
-30 °C to +80 °C
Voltage Rating:
300 VAC

ZF1

Insulator Material:
Liquid Crystal Polymer
Contact Material:
Phosphor Bronze
Plating:
Sn over 40 μ" (1.02 μm) Ni
Weld Tab: Phosphor Bronze
Operating Temp Range:
-55 °C to +105 °C

FC1

Insulator Material:
Liquid Crystal Polymer
Contact Material:
Phosphor Bronze
Plating:
Sn over 50 μ" (1.27 μm) Ni
Operating Temp Range:
-55 °C to +105 °C
Max Cycles:
25 with FJ

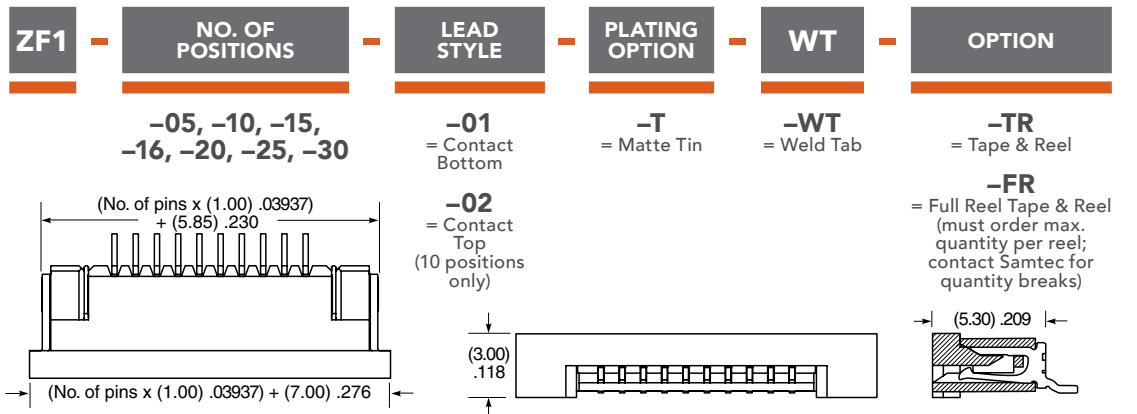
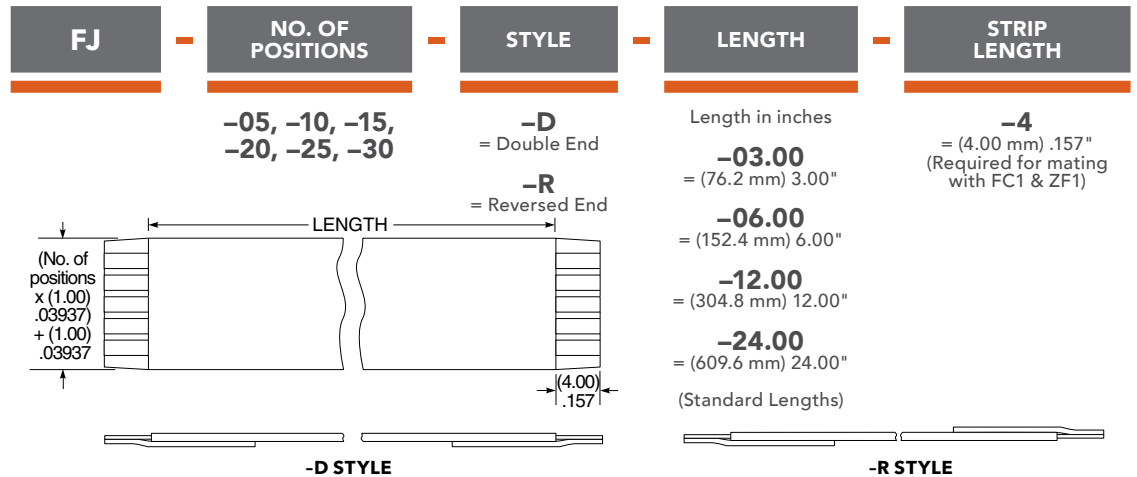

PROCESSING

ZF1/FC1

Lead-Free Solderable:
Yes
SMT Lead Coplanarity:
(0.10 mm) .004" max

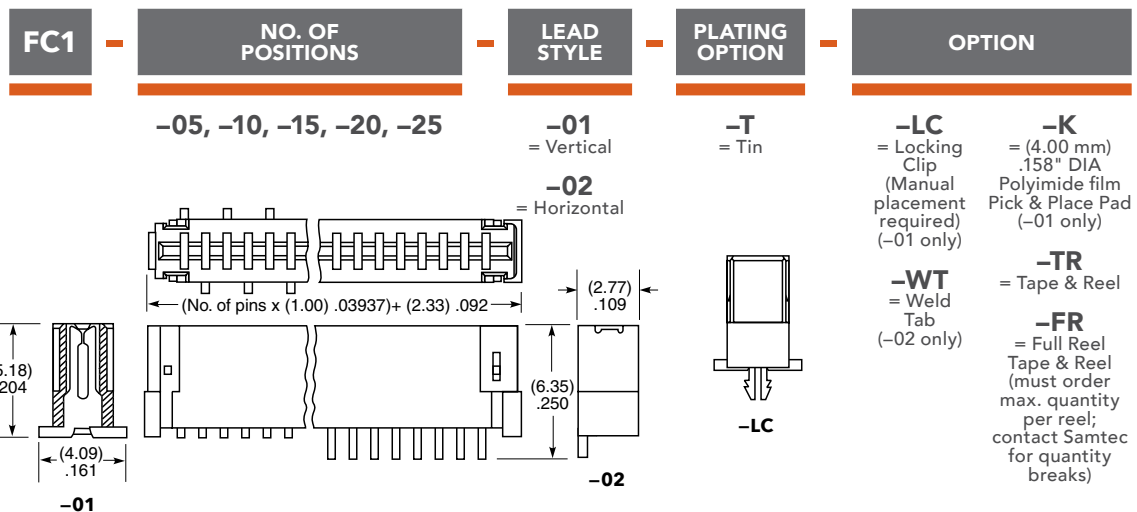



Notes:

FJ Stiffener color will be blue or black at Samtec's discretion.

Some sizes, styles and options are non-standard, non-returnable.

Looking for pricing, stock, or lifecycle information?

Click below to explore more details on WIN SOURCE:

-  [View FC1-10-01-T-K-TR on WIN SOURCE](#)
-  [Samtec Inc. Information](#)

Optimize Your Supply Chain with WIN SOURCE Solutions

-  Global Sourcing Solution
-  Obsolete Management
-  Cost Control Management
-  Shortage Management
-  Alternative Solution
-  Excess Inventory Management