



**THE DATASHEET OF
F2932NBGP8**



GENERAL DESCRIPTION

The F2932 is a high reliability, low insertion loss, 50 Ω SP2T absorptive RF switch designed for a multitude of wireless and other RF applications. This device covers a broad frequency range from 50 MHz to 8000 MHz. In addition to providing low insertion loss, the F2932 also delivers high linearity and high isolation performance while providing a 50 Ω termination to the unused RF input port.

The F2932 uses a single positive supply voltage of 2.7 V to 5.5 V supporting three states using either 3.3 V or 1.8 V control logic.

COMPETITIVE ADVANTAGE

The F2932 provides the following advantages

- ✓ Insertion Loss = 0.79 dB*
 - ✓ RFX to RFC Isolation = 67 dB*
 - ✓ IIP3 = +64 dBm*
 - ✓ Active Port Operating Power Handling = 34 dBm
 - ✓ Term Port Operating Power Handling = 27 dBm
 - ✓ Extended Temperature Range = -40°C to 105°C
- * 2 GHz

APPLICATIONS

- Base Station 2G, 3G, 4G
- Portable Wireless
- Repeaters and E911 systems
- Digital Pre-Distortion
- Point to Point Infrastructure
- Public Safety Infrastructure
- WIMAX Receivers and Transmitters
- Military Systems, JTRS radios
- RFID handheld and portable readers
- Test / ATE Equipment

FEATURES

- High Isolation:
 - 70 dB @ 1 GHz
 - 67 dB @ 2 GHz
 - 65 dB @ 3 GHz
 - 66 dB @ 4 GHz
- High Linearity:
 - IIP2 of 111 dBm
 - IIP3 of 64 dBm @ 2 GHz
- Wide Single Positive Supply Voltage Range
- 3.3 V and 1.8 V compatible control logic
- Operating temperature -40 °C to +105 °C
- 4 mm x 4 mm 16 pin QFN package

FUNCTIONAL BLOCK DIAGRAM

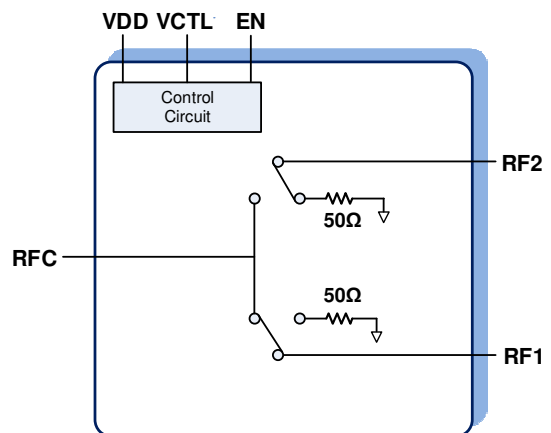

ORDERING INFORMATION

F2932NBGP8

Green

Tape & Reel

ABSOLUTE MAXIMUM RATINGS

| Parameter / Condition | | Symbol | Min | Max | Unit |
|-------------------------------------|----------------------------------------------|------------------------|------|---------------------------------------|------|
| V _{DD} to GND | | V _{DD} | -0.3 | +6.0 | V |
| VCTL, EN to GND | | V _{logic} | -0.3 | Lower of 3.6, V _{DD} +0.3 | V |
| RF1, RF2, RFC to GND | | V _{RF} | -0.3 | +0.3 | V |
| RF Input Power ¹ | RF1 or RF2 as an input (Connected to RFC) | P _{RF12} | | 36 | dBm |
| | RFC as an input (Connected to RF1 or RF2) | P _{RF12} | | 36 | |
| | RFC as an input (All off state) | P _{RF12_OFF} | | 30 | |
| | RF1 or RF2 as input (Terminated states) | P _{RF12_TERM} | | 30 | |
| | RF1 and RF2 as inputs (All Off State) | P _{RF12_OFF} | | 30 ² | |
| Maximum Junction Temperature | | T _{Jmax} | | +140 | °C |
| Storage Temperature Range | | T _{ST} | -65 | +150 | °C |
| Lead Temperature (soldering, 10s) | | T _{LEAD} | | +260 | °C |
| ESD Voltage – HBM (Per JESD22-A114) | | V _{ESDHBM} | | Class 2 (2500V) | |
| ESD Voltage – CDM (Per JESD22-C101) | | V _{ESDCDM} | | Class C3 (1000V) | |

Note 1: V_{DD} = 2.7 V to 5.5 V, 50 MHz ≤ F_{RF} ≤ 8000 MHz, T_c = 105 °C, Z_s = Z_L = 50 ohms.

Note 2: Each port.

Stresses above those listed above may cause permanent damage to the device. Functional operation of the device at these or any other conditions above those indicated in the operational section of this specification is not implied. Exposure to absolute maximum rating conditions for extended periods may affect device reliability.

PACKAGE THERMAL AND MOISTURE CHARACTERISTICS

| | |
|-----------------------------------------------------------------------------|----------|
| θ _{JA} (Junction – Ambient) | 60 °C/W |
| θ _{JC} (Junction – Case) The Case is defined as the exposed paddle | 3.9 °C/W |
| Moisture Sensitivity Rating (Per J-STD-020) | MSL 1 |

F2932 RECOMMENDED OPERATING CONDITIONS

| Parameter | Symbol | Condition | Min | Typ | Max | Units |
|------------------------------------------------------------------------------|----------------------|-----------------------------------------------------|----------------------|-----|------|-------------|
| Supply Voltage | V_{DD} | | 2.7 | | 5.5 | V |
| Operating Temp Range | T_{CASE} | Exposed Paddle Temperature | -40 | | +105 | $^{\circ}C$ |
| RF Frequency Range | F_{RF} | | 50 | | 8000 | MHz |
| RF Continuous Input CW Power (Non-Switched) ¹ | P_{RF} | RFC connected to RF1 or RF2 ² | $T_C = 85^{\circ}C$ | | 34 | dBm |
| | | | $T_C = 105^{\circ}C$ | | 34 | |
| | | RF1/ RF2 Input, Terminated State ^{3, 4} | $T_C = 85^{\circ}C$ | | 27 | |
| | | | $T_C = 105^{\circ}C$ | | 27 | |
| | | RFC Input, All off State | $T_C = 85^{\circ}C$ | | 27 | |
| | | $T_C = 105^{\circ}C$ | | 27 | | |
| RF Continuous Input Power (RF Hot Switching CW) ¹ | P_{RFSW} | RFC Input, switching between RF1 and RF2. | $T_C = 85^{\circ}C$ | | 30 | dBm |
| | | | $T_C = 105^{\circ}C$ | | 30 | |
| | | RFC Input, switching into or out of All off State. | $T_C = 85^{\circ}C$ | | 27 | |
| | | | $T_C = 105^{\circ}C$ | | 27 | |
| | | RF1 or RF2 as input, switched between RFC and Term. | $T_C = 85^{\circ}C$ | | 27 | |
| | | | $T_C = 105^{\circ}C$ | | 27 | |
| RF1 and RF2 as inputs, switching into or out of All off State ⁴ . | $T_C = 85^{\circ}C$ | | 27 | | | |
| | $T_C = 105^{\circ}C$ | | 27 | | | |
| RF1/2 Port Impedance | Z_{RFx} | | | 50 | | Ω |
| RFC Port Impedance | Z_{RFC} | | | 50 | | |

Note 1: Levels based on: $V_{DD} = 3.1\text{ V to }5.5\text{ V}$, $50\text{ MHz} \leq F_{RF} \leq 8000\text{ MHz}$, $Z_S = Z_L = 50\text{ ohms}$. See Figure 1 for power handling derating vs RF frequency.

Note 2: Input could be: RFC, RF1, or RF2 (applied to only one input).

Note 3: Any RF1 / RF2 termination state. Power level specified is for each port.

Note 4: Power level specified is for each port.

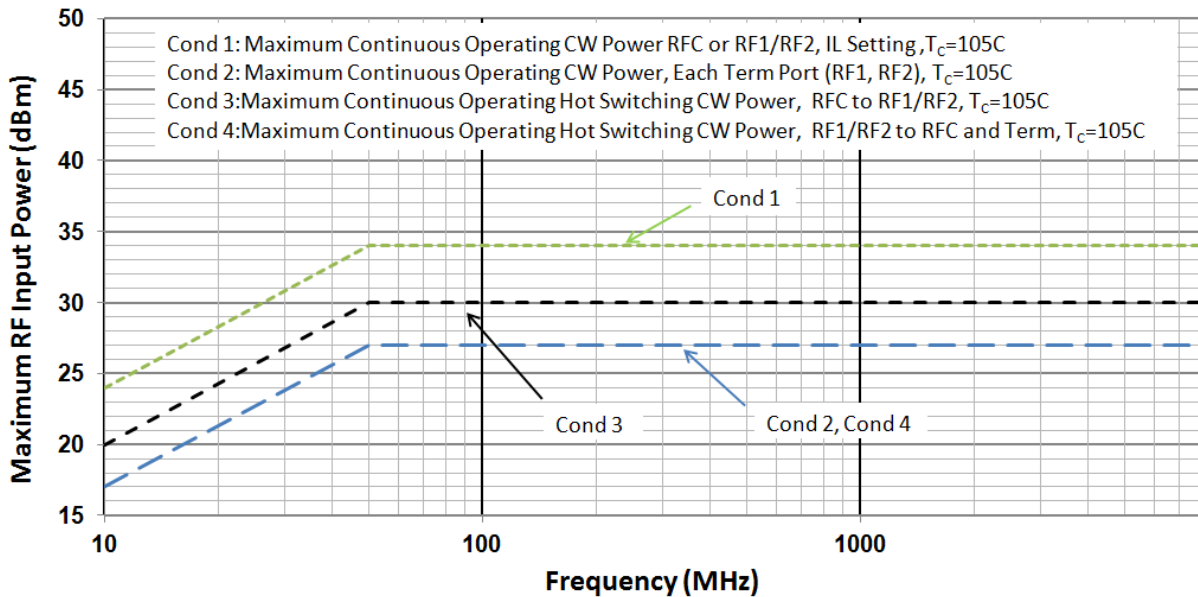

Figure 1: Maximum RF Input Operating Power vs. RF Frequency

F2932 SPECIFICATION

Typical Application Circuit, $V_{DD} = 5.0\text{ V}$, $T_C = +25\text{ }^\circ\text{C}$, $F_{RF} = 2000\text{ MHz}$, Driven Port = RF1 or RF2, input power = 10 dBm, $Z_S = Z_L = 50\text{ ohms}$, PCB board trace and connector losses are de-embedded unless otherwise noted.

| Parameter | Symbol | Condition | Min | Typ | Max | Units |
|------------------------------------|------------------|-------------------------|-----------------------|------|--------------------------------------------|---------------|
| Logic Input High Threshold | V_{IH} | | 1.1 | | Lower of (3.6, V_{DD}) | V |
| Logic Input Low Threshold | V_{IL} | | -0.3 | | 0.6 | V |
| Logic Current | I_{IH}, I_{IL} | For each control pin | -1 | | +1 | μA |
| DC Current | I_{DD} | $V_{DD} = 3.3\text{ V}$ | | 200 | 260¹ | μA |
| | | $V_{DD} = 5.0\text{ V}$ | | 260 | 325 | |
| Insertion Loss RFC to RF1 / RF2 | IL | 50 MHz | | 0.68 | | dB |
| | | 1 GHz | | 0.73 | | |
| | | 2 GHz | | 0.79 | 1.1 | |
| | | 3 GHz | | 0.82 | | |
| | | 4 GHz | | 0.93 | | |
| | | 6 GHz | | 1.06 | | |
| | | 8 GHz | | 1.6 | | |
| Isolation RFC to RF1 / RF2 | ISOC | 50 MHz | 77² | 79 | | dB |
| | | 1 GHz | 68 | 70 | | |
| | | 2 GHz | 63 | 67 | | |
| | | 3 GHz | 62 | 65 | | |
| | | 4 GHz | 60 | 66 | | |
| | | 6 GHz | 53 | 63 | | |
| | | 8 GHz | | 45 | | |
| Isolation RF1 to RF2 | ISOX | 50 MHz | | 86 | | dB |
| | | 1 GHz | | 64 | | |
| | | 2 GHz | | 58 | | |
| | | 3 GHz | | 54 | | |
| | | 4 GHz | | 51 | | |
| | | 6 GHz | | 45 | | |
| | | 8 GHz | | 37 | | |
| Return Loss RFC, RF1, RF2 | RF_{RL} | 50 MHz | | 25 | | dB |
| | | 1 GHz | | 25 | | |
| | | 2 GHz | | 23 | | |
| | | 3 GHz | | 24 | | |
| | | 4 GHz | | 20 | | |
| | | 6 GHz | | 18 | | |
| | | 8 GHz | | 14 | | |
| Return Loss RF1, RF2 Terminated | RF_{RLTERM} | 50 MHz | | 40 | | dB |
| | | 1 GHz | | 31 | | |
| | | 2 GHz | | 35 | | |
| | | 3 GHz | | 23 | | |
| | | 4 GHz | | 17 | | |
| | | 6 GHz | | 19 | | |
| | | 8 GHz | | 22 | | |

Note 1: Items in min/max columns in **bold italics** are Guaranteed by Test.

Note 2: Items in min/max columns that are not bold/italics are Guaranteed by Design Characterization.

F2932 SPECIFICATION (CONT.)

Typical Application Circuit, $V_{DD} = 5.0\text{ V}$, $T_C = +25\text{ }^\circ\text{C}$, $F_{RF} = 2000\text{ MHz}$, Driven Port = RF1 or RF2, input power = 10 dBm, $Z_S = Z_L = 50\text{ ohms}$, PCB board trace and connector losses are de-embedded unless otherwise noted.

| Parameter | Symbol | Condition | Min | Typ | Max | Units |
|----------------------------------------|----------------------|-----------------------------------------------------------------------------------------------------------------------------------------------------------------|---------|------|------|------------------|
| Input 1dB Compression ³ | ICP _{1dB} | 50 MHz | | 33.2 | | dBm |
| | | 1 GHz | | 35.5 | | |
| | | 2 GHz | | 36.5 | | |
| | | 3 GHz | | 36.1 | | |
| | | 4 GHz | | 35.3 | | |
| Input 0.1dB Compression ³ | ICP _{0.1dB} | $V_{DD} = 5.0\text{ V}$ | 50 MHz | | 30.4 | dBm |
| | | | 2 GHz | | 32.3 | |
| | | | 3 GHz | | 32.6 | |
| | | | 4 GHz | | 32.2 | |
| | | $V_{DD} = 3.1\text{ V}$ | 50 MHz | | 30.1 | |
| | | | 2 GHz | | 32.1 | |
| | | | 3 GHz | | 32.6 | |
| | | | 4 GHz | | 32.1 | |
| Input IP2 | IIP2 | $F_{RF1} = 2000\text{ MHz}$, $F_{RF2} = 1990\text{ MHz}$ $RF_{IN} = RF1\text{ or }RF2$ $P_{IN} = +20\text{ dBm / tone}$ $F_{IP2} = F_{RF1} + F_{RF2}$ | | 111 | | dBm |
| Input IP3 | IIP3 | RF Input = RF1 or RF2 $P_{IN} = +15\text{ dBm/tone}$ $\Delta F = 1\text{ MHz}$ | 50 MHz | | 58 | dBm |
| | | | 1 GHz | | 64 | |
| | | | 2 GHz | | 64 | |
| | | | 2.5 GHz | | 63.4 | |
| | | | 4 GHz | | 63.6 | |
| Non-RF Driven Spurious ⁴ | Spur _{MAX} | At any RF port when externally terminated into 50 Ω | | -114 | | dBm |
| Switching Time ⁵ | T _{SW} | 50% control to 90% RF | | 210 | | ns |
| | | 50% control to 10% RF | | 115 | | |
| | | 50% control to RF settled to within +/- 0.1 dB of I.L. value | | 225 | | |
| Maximum Switching Rate ⁶ | SW _{RATE} | | | 25 | | kHz |
| Maximum Video Feed-through on RF Ports | VID _{FT} | 5 MHz to 1000 MHz Measured with 20 ns risetime, 0 to 3.3 V control pulse | | 12 | | mV _{pp} |

Note 1: Items in min/max columns in ***bold italics*** are Guaranteed by Test.

Note 2: Items in min/max columns that are not bold/italics are Guaranteed by Design Characterization.

Note 3: The input 1 dB compression point is a linearity figure of merit. Refer to the Recommended Operating Conditions section for the specified maximum operating power levels.

Note 4: Spurious due to on-chip negative voltage generator. Typical generator fundamental frequency is 5.2 MHz.

Note 5: $F_{RF} = 1\text{ GHz}$.

Note 6: Minimum time required between switching of states = 1/ (Maximum Switching Rate).

Control Mode

Table 1 - Switch Control Truth Table

| VCTL | EN | RFC to RF1 | RFC to RF2 |
|------|----|------------|------------|
| 0 | 0 | OFF | ON |
| 1 | 0 | ON | OFF |
| 0 | 1 | OFF | OFF |
| 1 | 1 | OFF | OFF |

TYPICAL OPERATING CONDITIONS (TOC)

Unless otherwise noted for the TOC graphs on the following pages, the following conditions apply.

- $V_{DD} = 3.3 \text{ V}$
- $T_C = +25 \text{ }^\circ\text{C}$ ($T_C = \text{Temperature of Exposed Paddle}$)
- $F_{RF} = 2000 \text{ MHz}$
- $Z_S = Z_L = 50 \text{ } \Omega$
- $P_{IN} = +10 \text{ dBm}$ for all small signal tests.
- $P_{IN} = +15 \text{ dBm}$ /tone applied to RF1 or RF2 port for two tone linearity tests.
- Two tone frequency spacing = 1 MHz.
- RF1 or RF2 is the driven RF port and RFC is the output port.
- All unused RF ports terminated into 50 ohms.
- For Insertion Loss and Isolation plots, RF trace and connector losses are de-embedded (see EVKIT Board and Connector loss plot).
- Plots for Isolation and Insertion Loss over temperature and voltage are for a typical path. For performance of a specific path, refer to the online S-Parameter file.

TYPICAL OPERATING CONDITIONS (- 1 -)

RF1 to RFC Insertion Loss

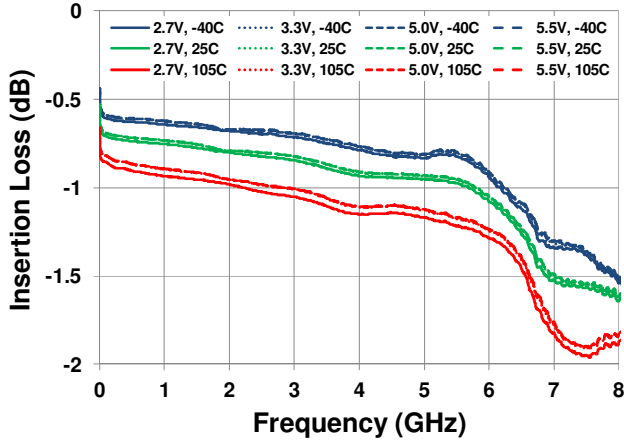

RF2 to RFC Insertion Loss

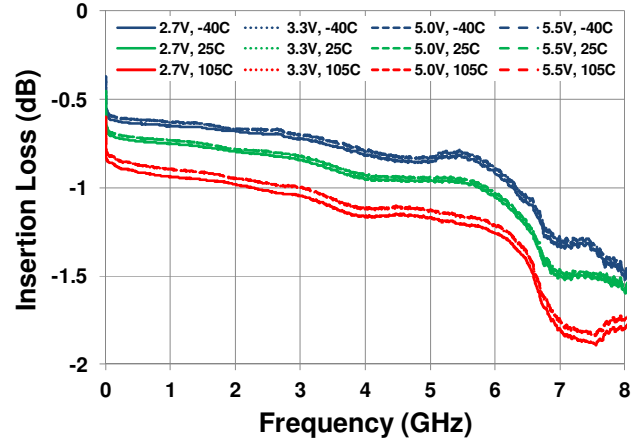

RF1 Port Match [On State]

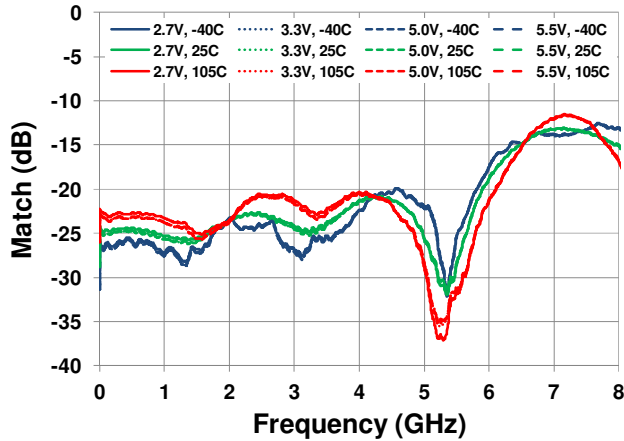

RF2 Port Match [On State]

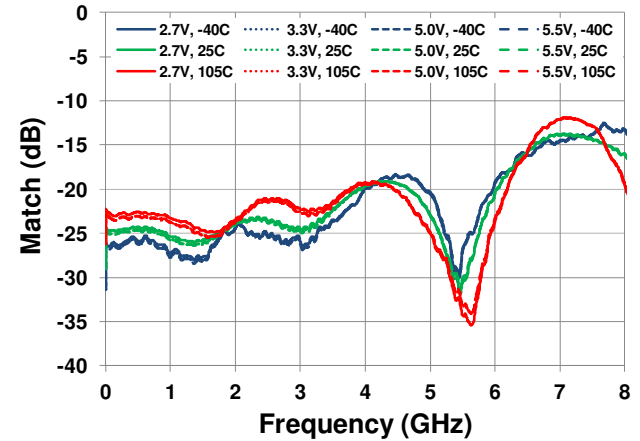

RF1 Port Match [Terminated State]

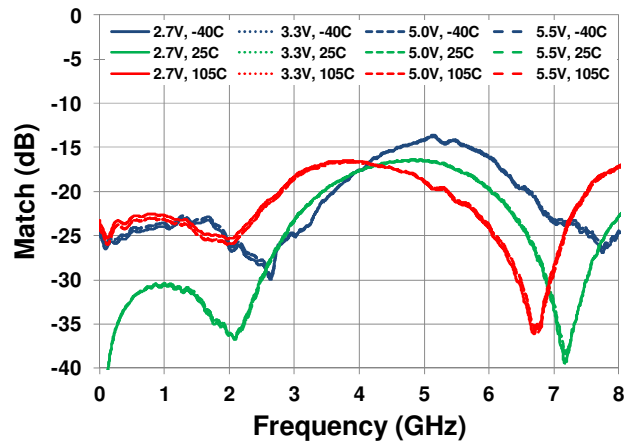

RF2 Port Match [Terminated State]

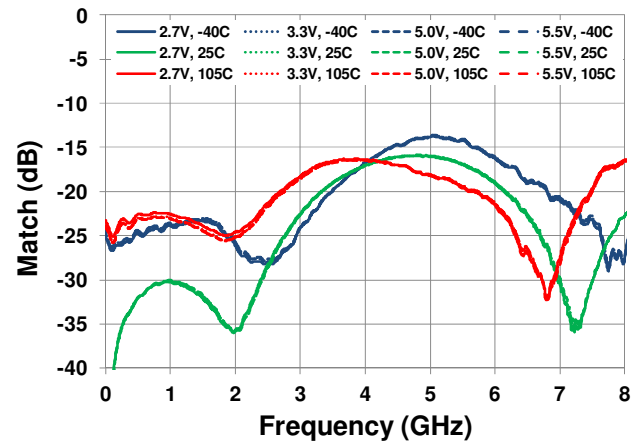

TYPICAL OPERATING CONDITIONS (- 2 -)

RFC Port Match [RF1 On State]

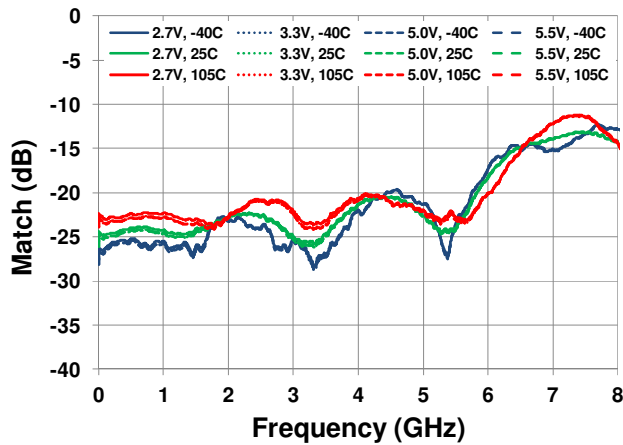

RFC Port Match [RF2 On State]

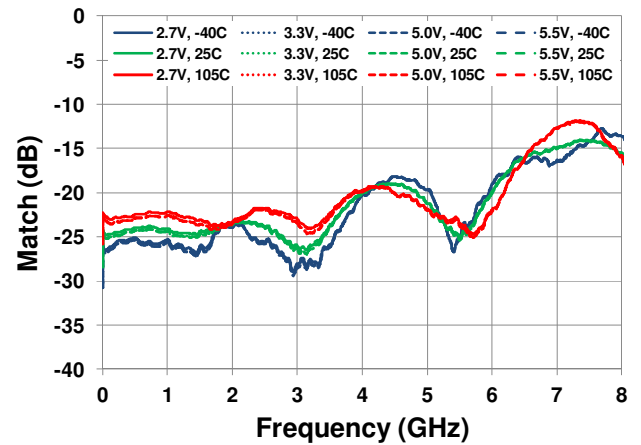

RF1 to RFC Isolation [RF2 On State]

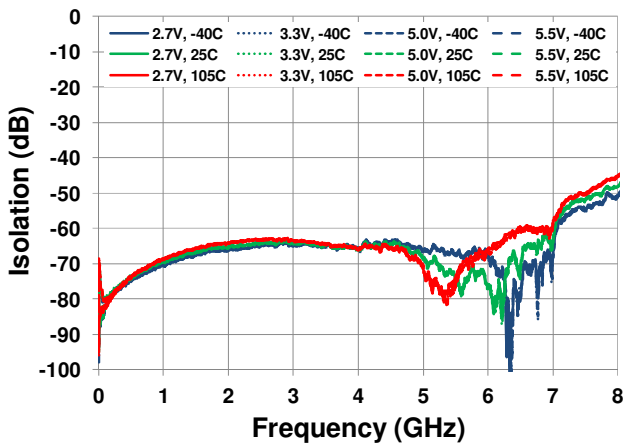

RF2 to RFC Isolation [RF1 On State]

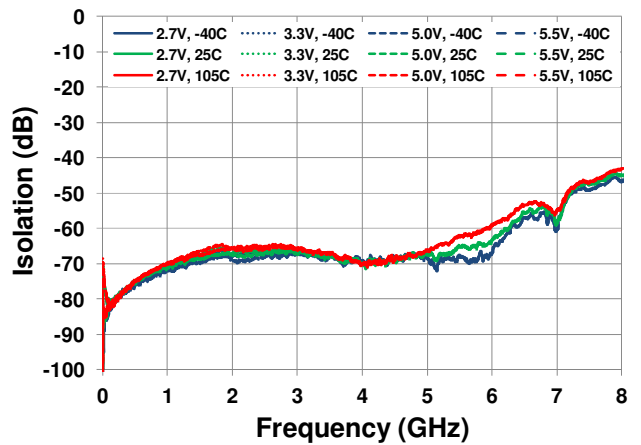

RF1 to RF2 Isolation [RF1 On State]

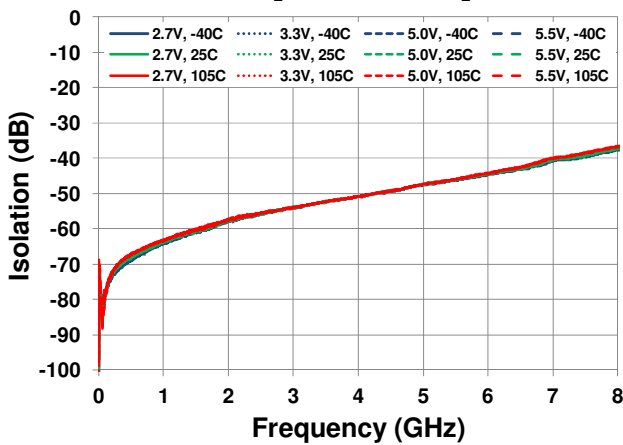

RF2 to RF1 Isolation [RF2 On State]

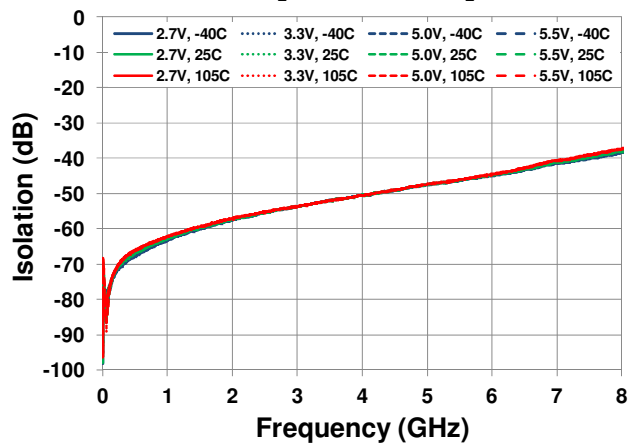

TYPICAL OPERATING CONDITIONS (- 3 -)

RF1 to RFC Isolation [All Off State]

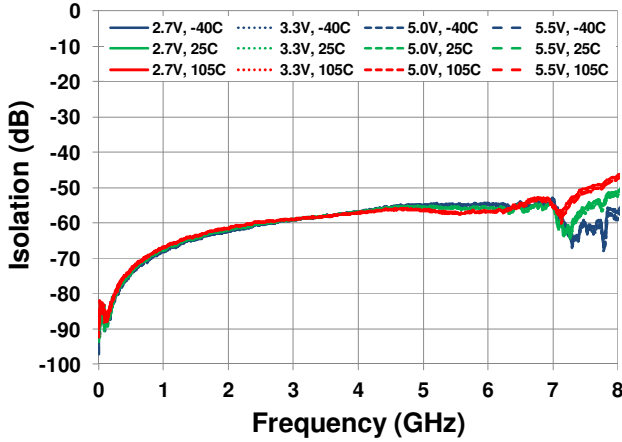

RF2 to RFC Isolation [All Off State]

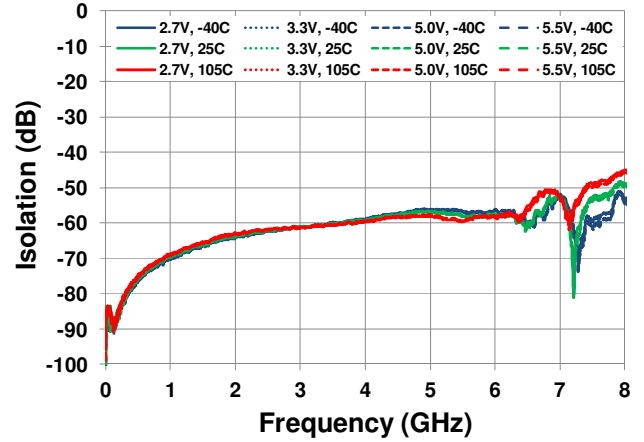

RF1 to RF2 Isolation [All Off State]

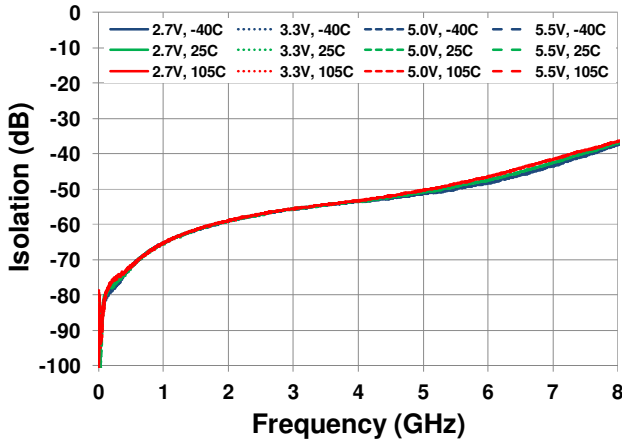

EVKIT PCB and Connector Thru Loss

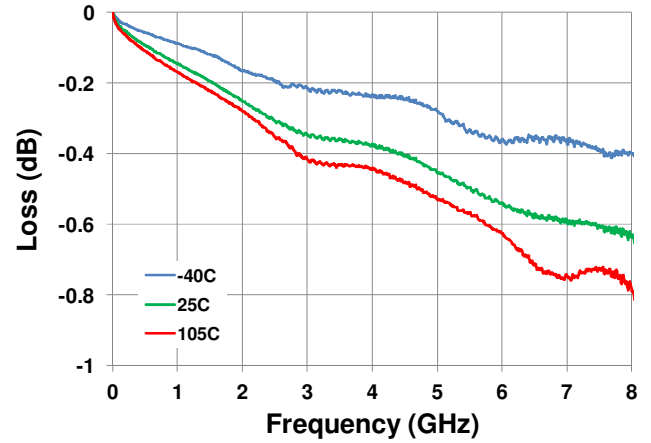

Input IP3 RF1 Port [T_C operating = -40C to 105C]

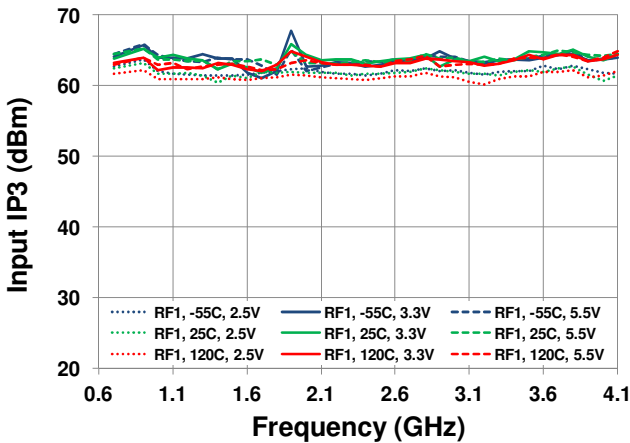

Input IP3 RF2 Port [T_C operating = -40C to 105C]

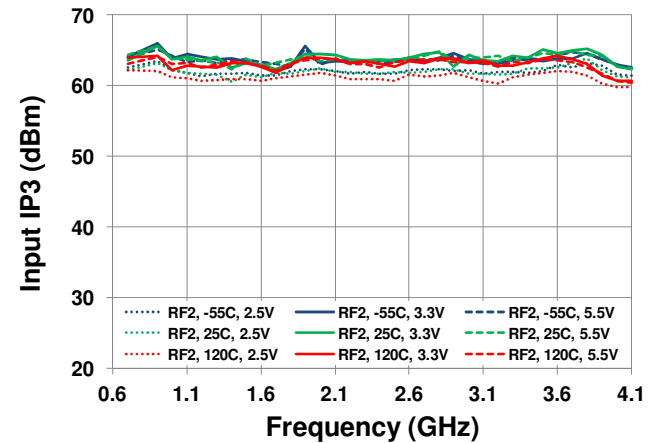

TYPICAL OPERATING CONDITIONS (- 4 -)

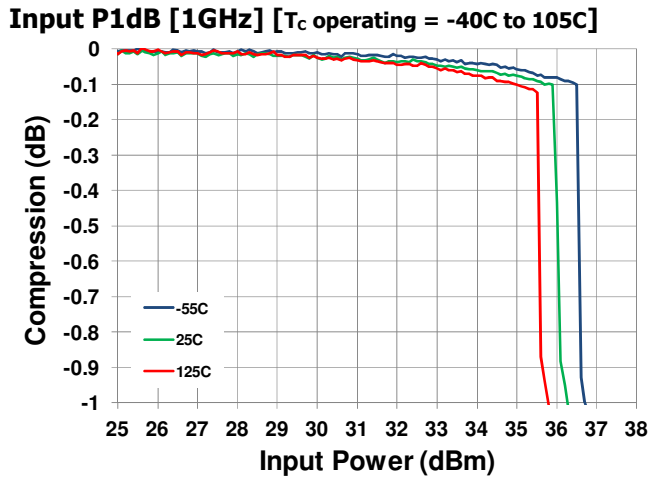

PACKAGE DRAWING

(4 mm x 4 mm 16-pin QFN), NBG16

Note: The F2932 uses EPAD Option P1 and Lead Option Z1

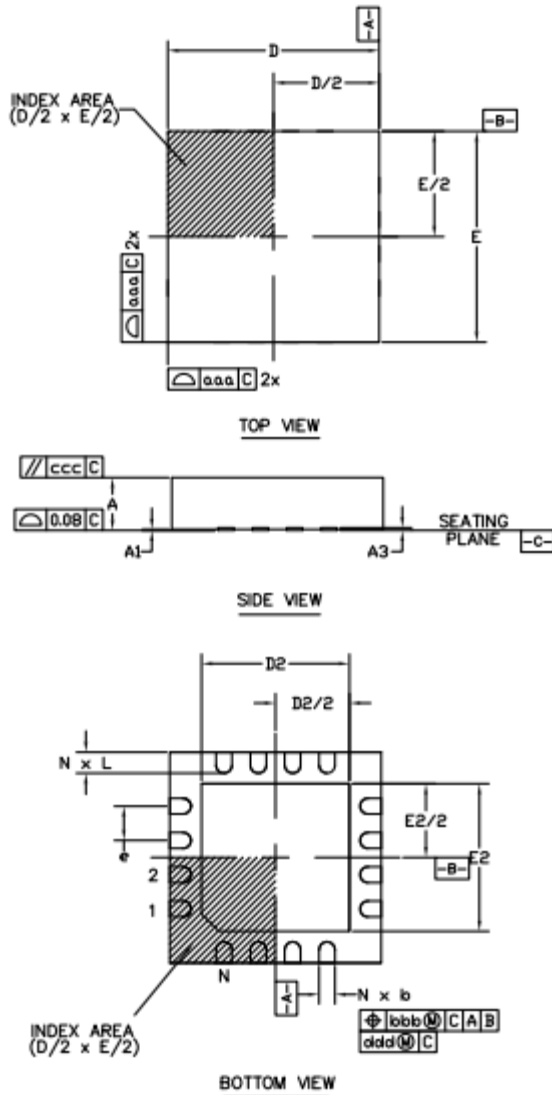

| SYMBOL | MIN | NOM | MAX |
|--------|----------|------|------|
| A | 0.80 | 0.90 | 1.00 |
| A1 | 0.00 | 0.02 | 0.05 |
| A3 | 0.02 ref | | |
| b | 0.25 | 0.30 | 0.35 |
| D | 4.0 | | |
| E | 4.0 | | |
| e | 0.65 | | |
| N | 16 | | |
| ND | 4 | | |
| NE | 4 | | |
| aaa | 0.15 | | |
| bbb | 0.10 | | |
| ccc | 0.10 | | |
| ddd | 0.05 | | |

EPAD OPTION:

| | P1 | | |
|----|------|------|------|
| | MIN | NOM | MAX |
| D2 | 2.30 | 2.40 | 2.50 |
| E2 | 2.30 | 2.40 | 2.50 |

LEAD OPTION:

| | Z1 | | |
|---|------|------|------|
| | MIN | NOM | MAX |
| L | 0.45 | 0.55 | 0.65 |

NOTES:

1. All dimensions in mm.
2. The dimension and tolerancing meet ASME Y-14.5M-1994.

LAND PATTERN DIMENSION

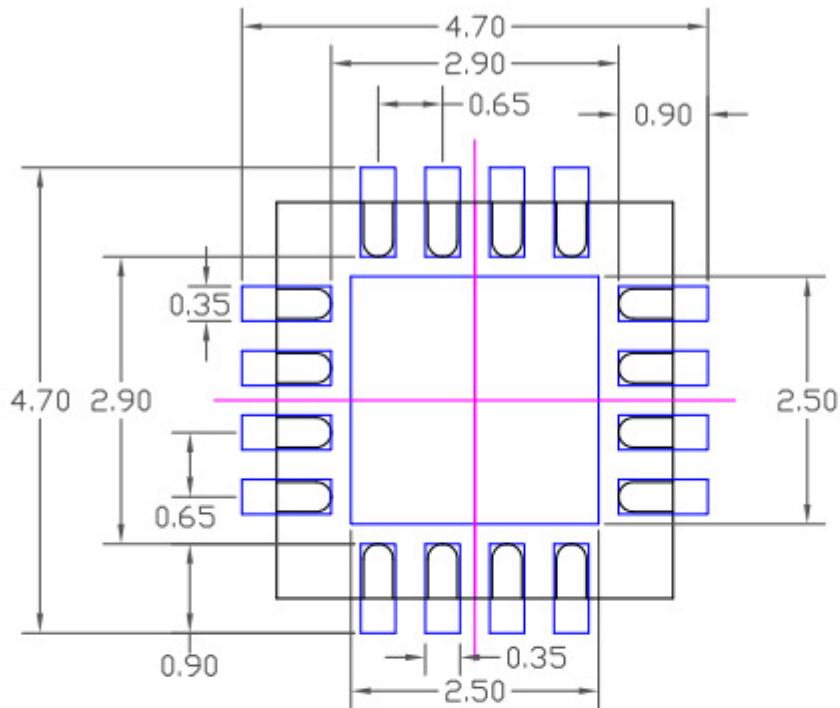

P1/Z1 OPTION

RECOMMENDED LAND PATTERN DIMENSION

NOTE:

- 1) ALL dimensions are in mm, Angles in degrees.
- 2) Top down view, as view on PCB.
- 3) Land Pattern in BLUE.NSMD Land Pattern Assumed
- 4) Land Pattern Recommendation as per IPC-7351B generic requirement for surface mount design and Land Pattern.

PIN DIAGRAM

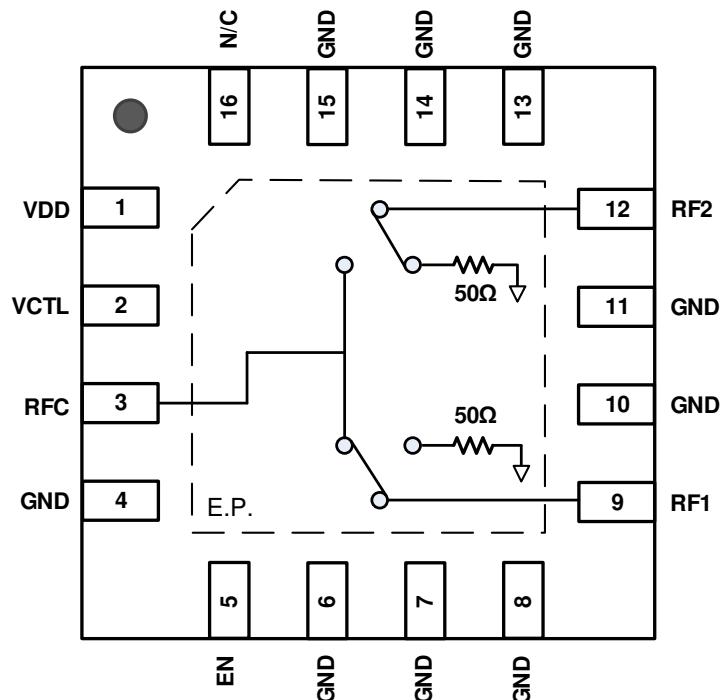

PIN DESCRIPTION

| PIN | NAME | FUNCTION |
|------------------------------------|------|--------------------------------------------------------------------------------------------------------------------------------------------------------------------------------------------------------------------------------------------------------------------------------|
| 1 | VDD | Power Supply. Bypass to GND with capacitors shown in the Typical Application Circuit as close as possible to pin. |
| 2 | VCTL | Controls the selected path when EN is low. Is disabled when EN is logic high. See Table 1. |
| 3 | RFC | RF Common Port. Matched to 50 Ω when one of the 2 RF ports is selected. If this pin is not 0 V DC, then an external coupling capacitor must be used. |
| 4, 6, 7, 8, 10, 11, 13, 14, 15, 16 | GND | Ground. Also, internally connected to the ground paddle. Ground this pin as close to the device as possible. |
| 5 | EN | EN as a logic low allows VCTL to control the selected switch path. With EN set to logic high puts the part in all paths off state and disables the control of VCTL. See Table 1. |
| 9 | RF1 | RF1 Port. Matched to 50 Ω. If this pin is not 0 V DC, then an external coupling capacitor must be used. |
| 12 | RF2 | RF2 Port. Matched to 50 Ω. If this pin is not 0 V DC, then an external coupling capacitor must be used. |
| 17 | — EP | Exposed Pad. Internally connected to GND. Solder this exposed pad to a PCB pad that uses multiple ground vias to provide heat transfer out of the device and into the PCB ground planes. These multiple ground vias are also required to achieve the specified RF performance. |

APPLICATIONS INFORMATION

Default Start-up

There are no internal pull-up or pull-down resistors on the VCTL or EN pins.

Logic Control

Control pins VCTL and EN are used to set the state of the SP2T switch (see Table 1).

Power Supplies

A common VCC power supply should be used for all pins requiring DC power. All supply pins should be bypassed with external capacitors to minimize noise and fast transients. Supply noise can degrade noise figure and fast transients can trigger ESD clamps and cause them to fail. Supply voltage change or transients should have a slew rate smaller than $1\text{ V} / 20\ \mu\text{s}$. In addition, all control pins should remain at 0 V (+/- 0.3 V) while the supply voltage ramps or while it returns to zero.

Control Pin Interface

If control signal integrity is a concern and clean signals cannot be guaranteed due to overshoot, undershoot, ringing, etc., the following circuit at the input of each control pin is recommended. This applies to control pin 2 (VCTL) and pin 5 (EN) as shown below.

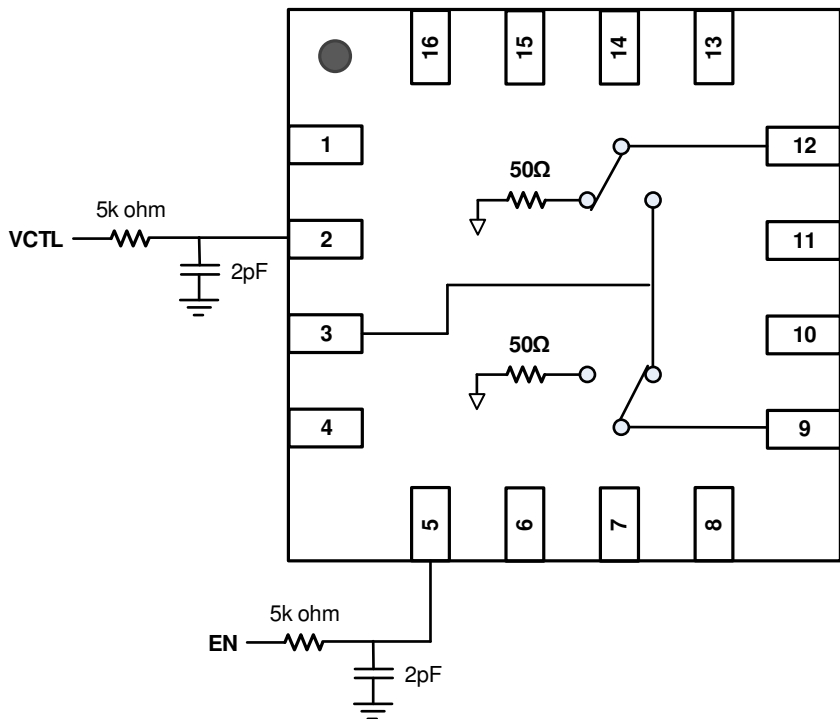

EVKIT PICTURES

TOP VIEW

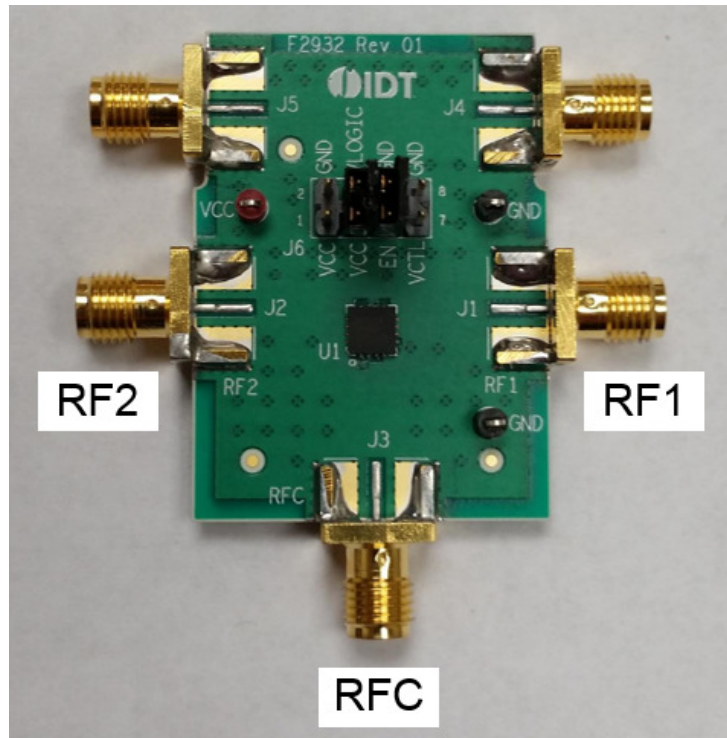

BOTTOM VIEW

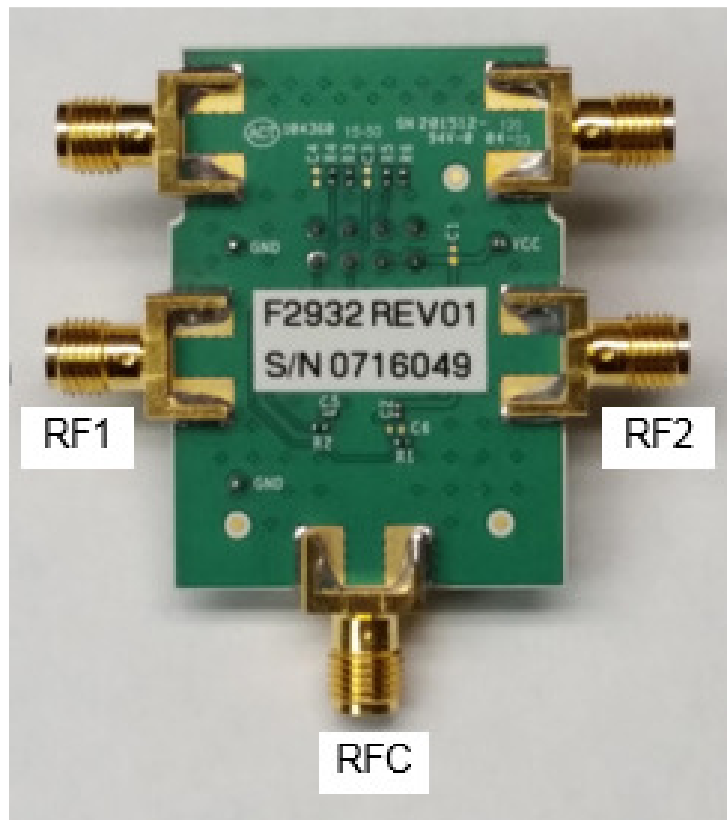

EVKIT / APPLICATIONS CIRCUIT

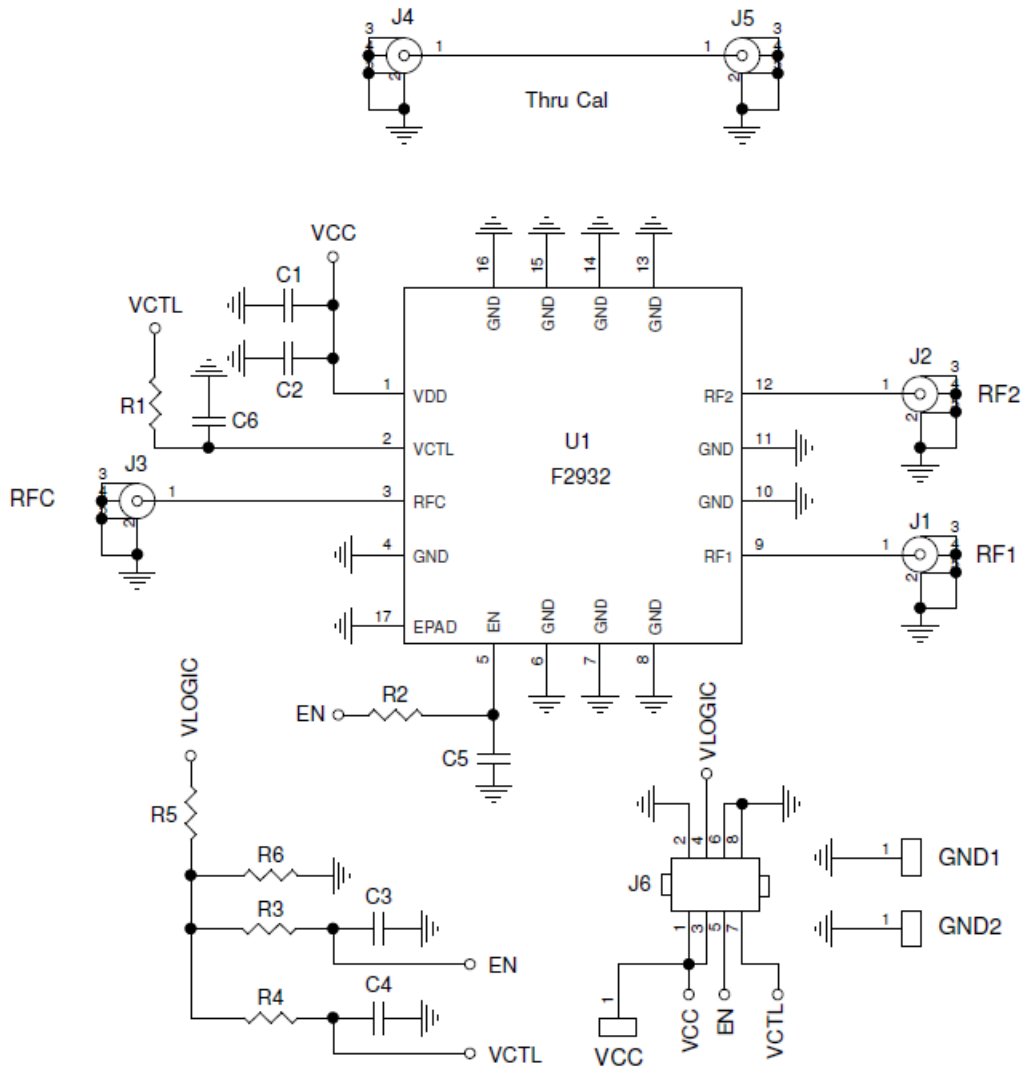

EVKIT BOM

| Part Reference | QTY | DESCRIPTION | Mfr. Part # | Mfr. |
|----------------|-----|-----------------------------------------------------------|-------------------|----------------------|
| C1 | 0 | Not Installed (0402) | | |
| C2 | 1 | 0.1 μ F \pm 10%, 16V, X7R, Ceramic Capacitor (0402) | GRM155R71C104K | Murata |
| C3, C4, C6 | 0 | Not Installed (0402) | | |
| C5 | 1 | 100 pF \pm 5%, 50V, C0G, Ceramic Capacitor (0402) | GRM1555C1H101J | Murata |
| R1, R2 | 2 | 100 Ω \pm 1%, 1/10W, Resistor (0402) | ERJ-2RKF1000X | Panasonic |
| R3, R4 | 2 | 100k Ω \pm 1%, 1/10W, Resistor (0402) | ERJ-2RKF1003X | Panasonic |
| R5 | 1 | 15k Ω \pm 1%, 1/10W, Resistor (0402) | ERJ-2RKF1502X | Panasonic |
| R6 | 1 | 18k Ω \pm 1%, 1/10W, Resistor (0402) | ERJ-2RKF1802X | Panasonic |
| J1 – J5 | 5 | SMA Edge Launch (0.375 inch pitch ground tabs) | 142-0701-851 | Emerson Johnson |
| J6 | 1 | CONN HEADER VERT 4x2 POS GOLD | 67997-108HLF | FCI |
| U1 | 1 | SP2T Switch 4 mm x 4 mm QFN16-EP | F2932NBGP | IDT |
| VCC | 1 | Test Point Loop (Red) | 5000 | Keystone Electronics |
| GND1, GND2 | 2 | Test Point Loop (Black) | 5001 | Keystone Electronics |
| | 1 | Printed Circuit Board | F2932 EVKIT REV 1 | IDT |

TOP MARKINGS

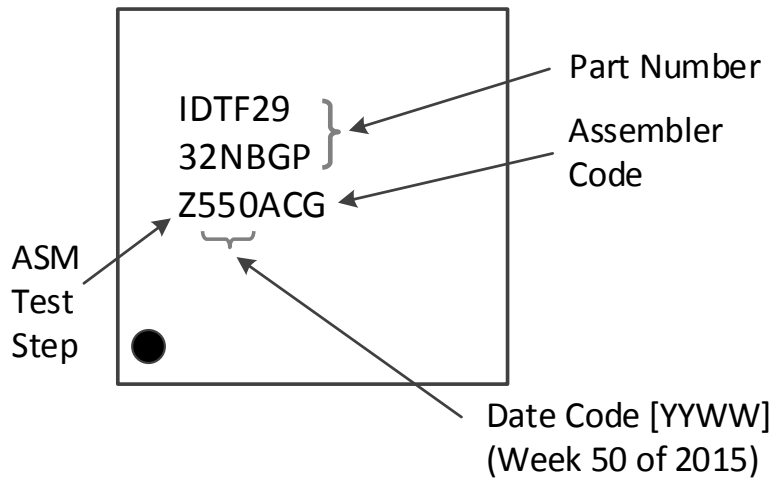

EVKIT OPERATION

External Supply Setup

Set up a VCC power supply in the voltage range of 2.7 V to 5.5 V and disable the power supply output.

Logic Control Setup

Using the EVKIT to manually set the control logic:

On connector J6 connect a 2-pin shunt from pin 3 (VCC) to pin 4 (VLOGIC). This connection provides the VCC voltage supply to the Eval Board logic control pull up network. Resistors R5 and R6 form a voltage divider to set the V_{high} level over the 2.7 V to 5.5 V VCC range for manual logic control.

Connector J6 has 2 logic input pins: EN (pin 5) and VCTL (pin 7). See Table 1 for Logic Truth Table. With the pullup network enabled (as noted above) these pins can be left open to provide a logic high through pull up resistors R3 and R4. To set a logic low for EN and VCTL connect 2-pin shunts on J6 from pin 5 (EN) to pin 6 (GND) and from pin 7 (VCTL) to pin 8 (GND).

Note that when using the on board R5 / R6 voltage divider the current draw from the VCC supply will be higher by approximately $VCC / 33k \Omega$.

Using external control logic:

Pins 3, 4, 6, and 8 of J6 should have no external connection. External logic controls are applied to J6 pin 5 (EN) and pin 7 (VCTL). See Table 1 for Logic Truth Table.

Turn on Procedure

Setup the supplies and Eval Board as noted in the **External Supply Setup** and **Logic Control Setup** sections above.

Connect the preset disabled VCC power supply to the red VCC loop and ground to GND1 or GND2.

Enable the VCC supply.

Set the desired logic setting using J6 pin 5 (EN) and pin 7 (VCTL) to achieve the desired Table 1 setting. Note that external control logic should not be applied without VCC being present.

Turn off Procedure

If using external control logic for EN and VCTL then set them to a logic low.

Disable the VCC supply.

Revision History Sheet

| Rev | Date | Page | Description of Change |
|------------|-------------|-------------|------------------------------|
| 0 | 2016-Feb-26 | | Initial release |
| 1 | 2016-May-03 | 1-5, 13, 15 | Updates |

IMPORTANT NOTICE AND DISCLAIMER

RENESAS ELECTRONICS CORPORATION AND ITS SUBSIDIARIES (“RENESAS”) PROVIDES TECHNICAL SPECIFICATIONS AND RELIABILITY DATA (INCLUDING DATASHEETS), DESIGN RESOURCES (INCLUDING REFERENCE DESIGNS), APPLICATION OR OTHER DESIGN ADVICE, WEB TOOLS, SAFETY INFORMATION, AND OTHER RESOURCES “AS IS” AND WITH ALL FAULTS, AND DISCLAIMS ALL WARRANTIES, EXPRESS OR IMPLIED, INCLUDING, WITHOUT LIMITATION, ANY IMPLIED WARRANTIES OF MERCHANTABILITY, FITNESS FOR A PARTICULAR PURPOSE, OR NON-INFRINGEMENT OF THIRD-PARTY INTELLECTUAL PROPERTY RIGHTS.

These resources are intended for developers who are designing with Renesas products. You are solely responsible for (1) selecting the appropriate products for your application, (2) designing, validating, and testing your application, and (3) ensuring your application meets applicable standards, and any other safety, security, or other requirements. These resources are subject to change without notice. Renesas grants you permission to use these resources only to develop an application that uses Renesas products. Other reproduction or use of these resources is strictly prohibited. No license is granted to any other Renesas intellectual property or to any third-party intellectual property. Renesas disclaims responsibility for, and you will fully indemnify Renesas and its representatives against, any claims, damages, costs, losses, or liabilities arising from your use of these resources. Renesas' products are provided only subject to Renesas' Terms and Conditions of Sale or other applicable terms agreed to in writing. No use of any Renesas resources expands or otherwise alters any applicable warranties or warranty disclaimers for these products.

(Disclaimer Rev.1.01 Jan 2024)

Corporate Headquarters

TOYOSU FORESIA, 3-2-24 Toyosu,
Koto-ku, Tokyo 135-0061, Japan
www.renesas.com

Trademarks



Renesas and the Renesas logo are trademarks of Renesas Electronics Corporation. All trademarks and registered trademarks are the property of their respective owners.

Contact Information

For further information on a product, technology, the most up-to-date version of a document, or your nearest sales office, please visit www.renesas.com/contact-us/.

Looking for pricing, stock, or lifecycle information?

Click below to explore more details on WIN SOURCE:

-  [View F2932NBGP8 on WIN SOURCE](#)
-  [Renesas Electronics America](#) Information

Optimize Your Supply Chain with WIN SOURCE Solutions

-  Global Sourcing Solution
-  Obsolete Management
-  Cost Control Management
-  Shortage Management
-  Alternative Solution
-  Excess Inventory Management