



THE DATASHEET OF EVQ-PPBA25



6.0 mm×3.5 mm Square Thin type
 Light Touch Switches
 for Reflow Soldering

Japan

Type: **EVQPP**



■ Features

- 6.0 mm×3.5 mm square thin type: 2.5 mm in height
- Excellent clear click feeling
- Reflow soldering available
- Dustproof structure

■ Recommended Applications

- Operating signal input switches for portable CD players, MD players, and communications equipment

■ Explanation of Part Numbers

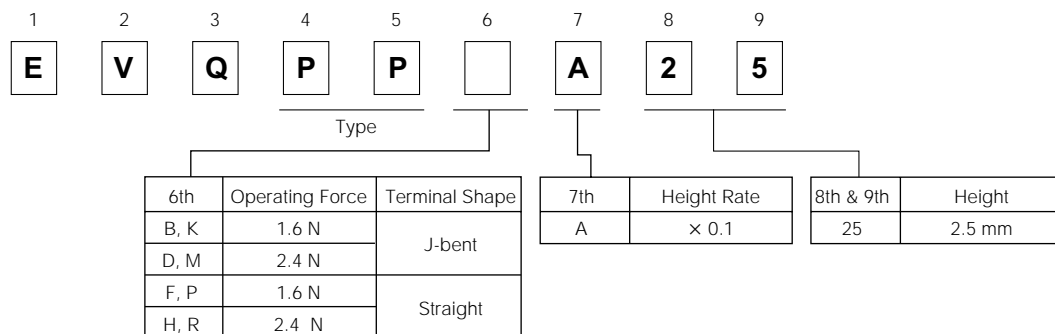



■ Specifications

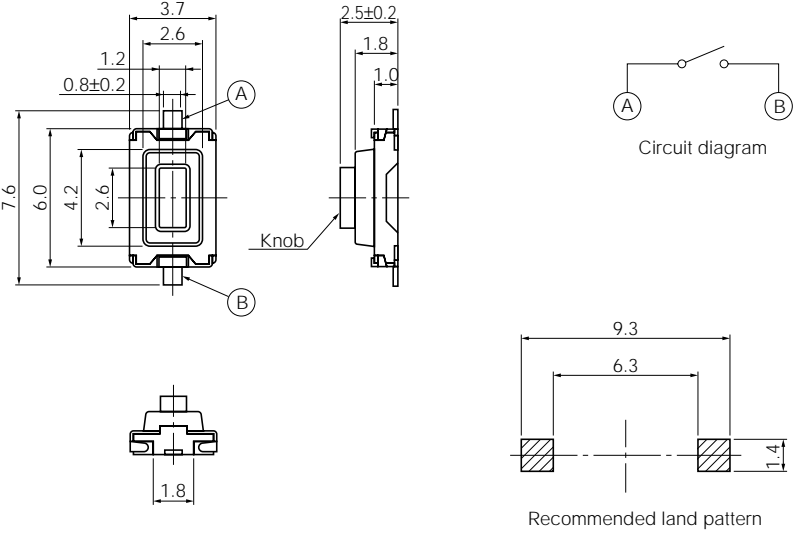

Type		Snap action / Push-on type SPST	
Electrical	Rating	50 mA 12 Vdc max. (Resistive load)	
	Contact Resistance	100 mΩ max.	
	Insulation Resistance	100 MΩ min. (at 100 Vdc)	
	Dielectric Withstanding Voltage	250 Vac for 1 minute	
	Bouncing	10 ms max. (ON, OFF)	
Mechanical	Operating Force	1.6 N±0.5 N	2.4 N±0.6 N
	Travel	0.25 mm ^{+0.2} / _{-0.1} mm	
Endurance	Operating Life	50000 cycles min.	30000 cycles min.
	Operating Temperature	-40 °C to +85 °C (45 % to 85 % RH)	
	Storage Temperature	-40 °C to +85 °C (Bulk) -20 °C to +60 °C (Taping)	
Minimum Quantity/Packing Unit		4000 pcs. Embossed Taping (Reel Pack)	
Quantity/Carton		20000 pcs.	

Design and specifications are each subject to change without notice. Ask factory for the current technical specifications before purchase and/or use. Should a safety concern arise regarding this product, please be sure to contact us immediately.

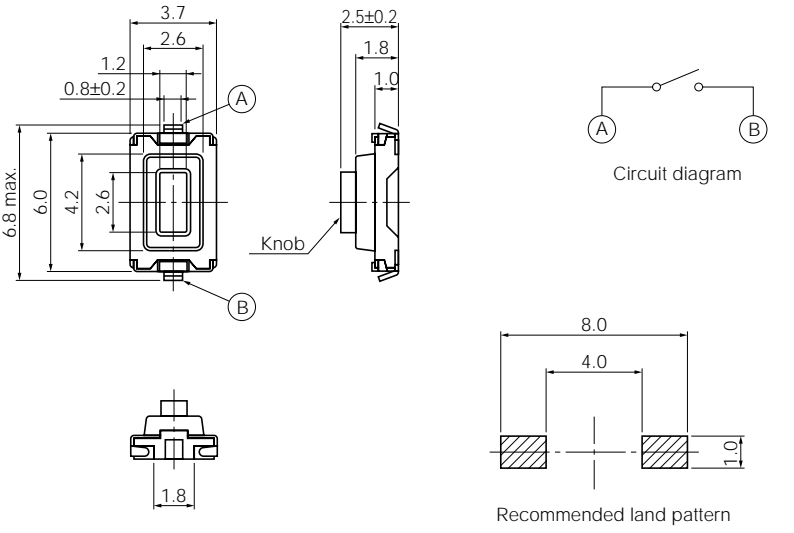
■ Dimensions in mm (not to scale)

<p>No. 1</p> <p>EVQPPF EVQPPH</p> <p>(Embossed Taping)</p> <p>With straight terminals Without ground terminal</p> 				
<p>Part Numbers</p>	<p>Operating Force</p>	<p>Height</p>	<p>Push Plate Color</p>	<p>Operating Life</p>
<p>EVQPPFA25</p>	<p>1.6 N</p>	<p>2.5 mm</p>	<p>Black</p>	<p>50000 cycles</p>
<p>EVQPPHA25</p>	<p>2.4 N</p>	<p>2.5 mm</p>	<p>White</p>	<p>30000 cycles</p>
<p>No. 2</p> <p>EVQPPB EVQPPD</p> <p>(Embossed Taping)</p> <p>With J-bent terminals Without ground terminal</p> 				
<p>Part Numbers</p>	<p>Operating Force</p>	<p>Height</p>	<p>Push Plate Color</p>	<p>Operating Life</p>
<p>EVQPPBA25</p>	<p>1.6 N</p>	<p>2.5 mm</p>	<p>Black</p>	<p>50000 cycles</p>
<p>EVQPPDA25</p>	<p>2.4 N</p>	<p>2.5 mm</p>	<p>White</p>	<p>30000 cycles</p>

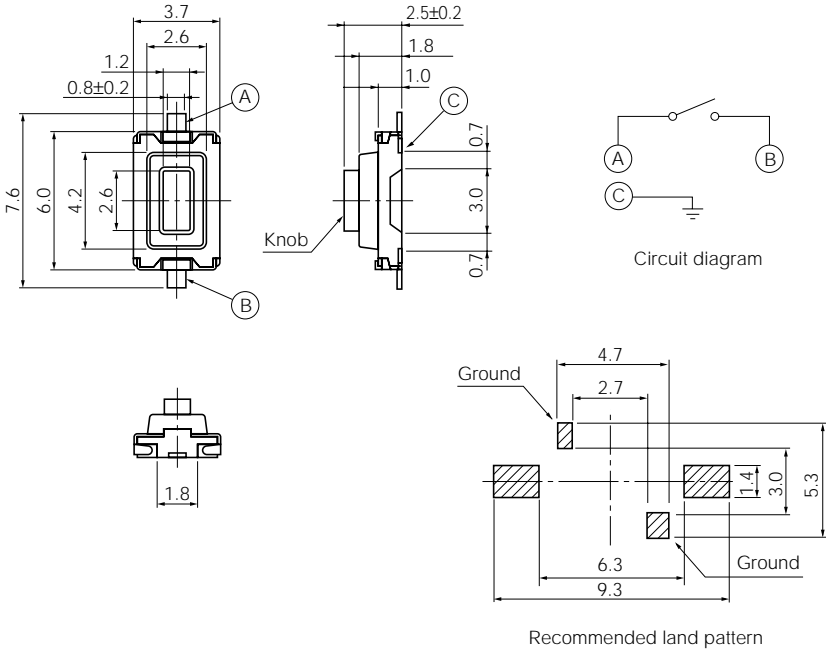
■ Dimensions in mm (not to scale)

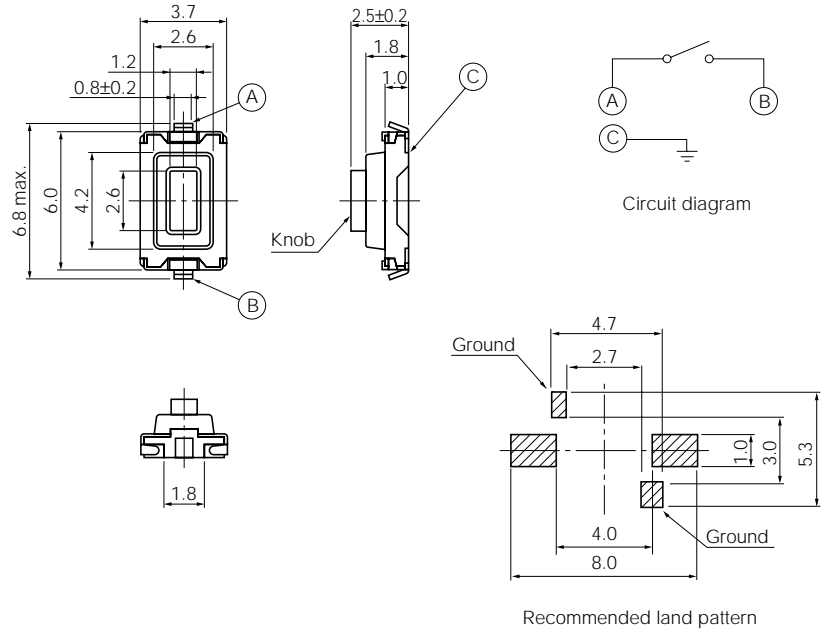
<p>No. 3</p> <p>EVQPPP EVQPPR</p> <p>(Embossed Taping)</p> <p>With straight terminals With ground terminal</p> 				
<p>Part Numbers</p>	<p>Operating Force</p>	<p>Height</p>	<p>Push Plate Color</p>	<p>Operating Life</p>
<p>EVQPPPA25</p>	<p>1.6 N</p>	<p>2.5 mm</p>	<p>Black</p>	<p>50000 cycles</p>
<p>EVQPPRA25</p>	<p>2.4 N</p>	<p>2.5 mm</p>	<p>White</p>	<p>30000 cycles</p>
<p>No. 4</p> <p>EVQPPK EVQPPM</p> <p>(Embossed Taping)</p> <p>With J-bent terminals With ground terminal</p> 				
<p>Part Numbers</p>	<p>Operating Force</p>	<p>Height</p>	<p>Push Plate Color</p>	<p>Operating Life</p>
<p>EVQPPKA25</p>	<p>1.6 N</p>	<p>2.5 mm</p>	<p>Black</p>	<p>50000 cycles</p>
<p>EVQPPMA25</p>	<p>2.4 N</p>	<p>2.5 mm</p>	<p>White</p>	<p>30000 cycles</p>

Recommended Reflow Soldering Conditions

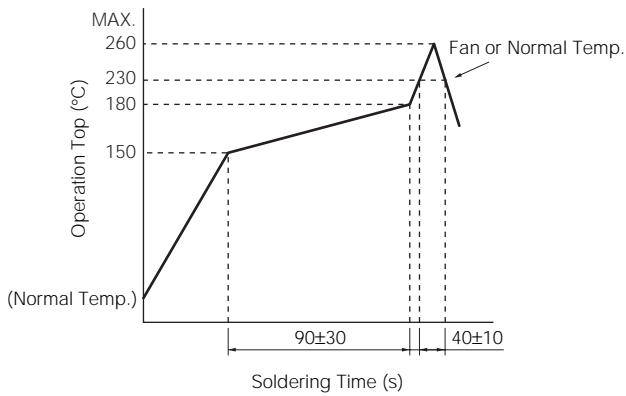

Embossed Carrier Taping

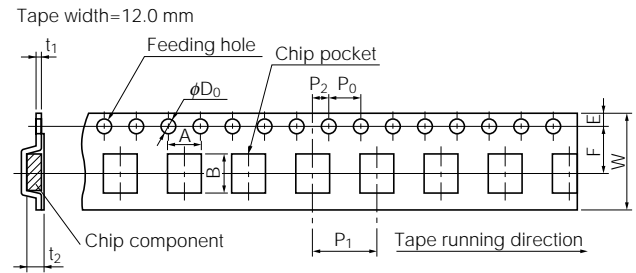

Unit: mm

Part No.	Height	A	B	W	F	E	P ₁	P ₂	P ₀	D ₀ Dia.	t ₁	t ₂
EVQPP	2.5	4.45±0.20	8.3 max.	12.0±0.3	5.5±0.1	1.75±0.10	8.0±0.1	2.0±0.1	4.0±0.1	1.5 ^{+0.1} ₋₀	0.30±0.05	2.55±0.20

Standard Reel Dimensions in mm (not to scale)

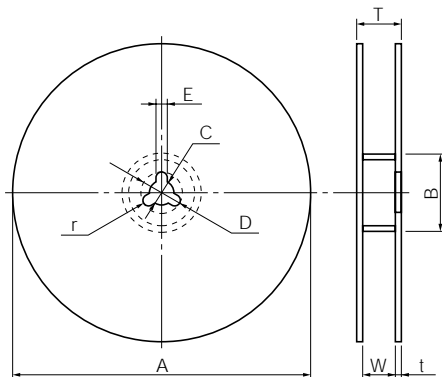



Item	A	B	C	D	E
Rate (mm)	φ370.0±2.0	φ50.0 min.	φ13.0±0.5	φ21.0±1.0	2.0±0.5

Item	W	T	t	r
Rate (mm)	14.0±1.5	—	1.0 to 3.0	1.0±0.5

Looking for pricing, stock, or lifecycle information?

Click below to explore more details on WIN SOURCE:

-  [View EVQ-PPBA25 on WIN SOURCE](#)
-  [Panasonic Information](#)

Optimize Your Supply Chain with WIN SOURCE Solutions

-  Global Sourcing Solution
-  Obsolete Management
-  Cost Control Management
-  Shortage Management
-  Alternative Solution
-  Excess Inventory Management