





**THE DATASHEET OF  
ESD5Z3V3**



**SPECIFICATION SHEET**

<b>SPECIFICATION SHEET NO.</b>	N0310- SOD523Z3V3S0ZE
<b>DATE</b>	Mar. 10, 2021
<b>REVISION</b>	A0
<b>DESCRIPTION</b>	SMD Plastic-Encapsulate ESD Protection Diodes, SOD-523 series, 2 pads ESD5Z3V3 Type, TVs for ESD protection, Polarity: Unipolar Reverse Working Voltage : 3.3V, Power Dissipation : 150mW Operating Temp. Range -55°C ~+150°C, Package in Tape/Reel, 3000pcs/Reel RoHS/RoHS III compliant
<b>CUSTOMER</b>	
<b>CUSTOMER PART NUMBER</b>	
<b>CROSS REF. PART NUMBER</b>	
<b>ORIGINAL PART NUMBER</b>	MDD ESD5Z3V3
<b>PART CODE</b>	SOD523Z3V3S0ZE

<b>VENDOR APPROVE</b>			
Issued/Checked/Approved			
DATE: March 10, 2021			

<b>CUSTOMER APPROVE</b>	
DATE:	

**SMD ESD PROTECTION DIODES (TUBE) SOD-523 SERIES**

**MAIN FEATURE**

- IEC61000-4-2 Levels 4 ESD Protection
- Protects one directional I/O line
- Low clamping voltage
- Low leakage current
- Working voltages : : 2.5V,3.3V,5V,6V,7V,12V,15V



**APPLICATION**

- Cell Phone Handsets and Accessories
- Microprocessor based equipment
- Personal Digital Assistants (PDA's)
- Notebooks, Desktops, and Servers
- Portable Instrumentation
- Peripherals

**RFQ**

[Request For Quotation](#)

**PART CODE GUIDE**

SOD523	Z3V3	S	OZE
1	2	3	4

- 1) **SOD523**: SMD Plastic-Encapsulate ESD Protection Diodes, SOD-523 series, 2 pads
- 2) **Z3V3**: Type code for original part number ESD5Z3V3
- 3) **S**: Package code, Package in Tape/Reel, 3000pcs/Reel
- 4) **OZE**: Marking code for "ZE" on the case surface, Different Marking for different specification.

**MORE ITEMS AVAILABLE**

SOD523Z2V5S0ZD	<b>SOD523Z3V3SOZE</b>	SOD523Z5V0S0ZF	SOD523Z6V0S0ZG	SOD523Z7V0S0ZH
SOD523Z12VS0ZM	SOD523Z15VS0ZN			

**SMD ESD PROTECTION DIODES (TUBE) SOD-523 SERIES**

**DIMENSION (Unit: Inch/mm)**

Image for reference

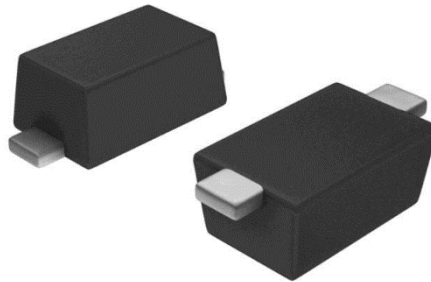

Marking: ZE

SOD-523

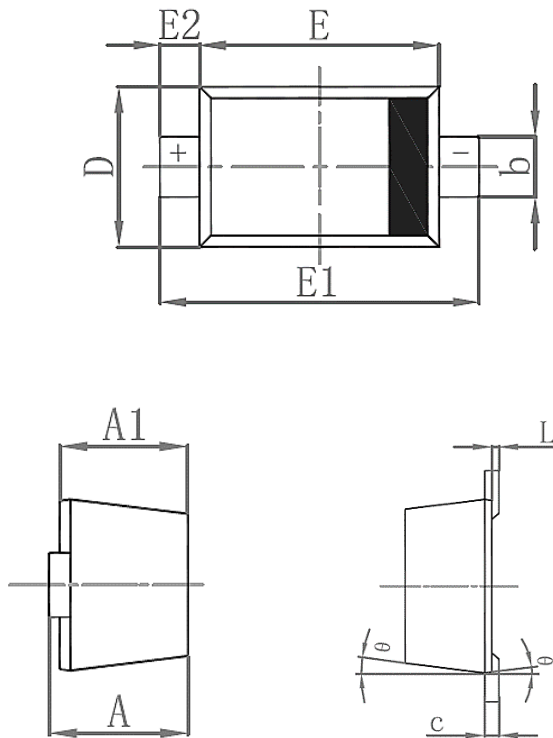

Symbol	Value ( mm )		
	Min.	Typ.	Max.
A	0.51		0.770
A1	0.50		0.70
b	0.250		0.350
c	0.080		0.150
D	0.750		0.850
E	1.10		1.30
E1	1.50		1.70
E2	0.20		
L	0.010		0.070
K	7°		

**Recommend Pad Layout**

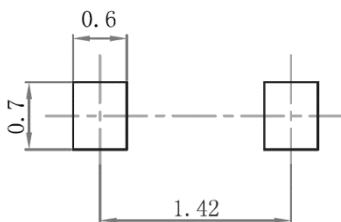

**Circuit Diagram**

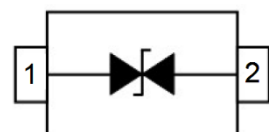

**SMD ESD PROTECTION DIODES (TUBE) SOD-523 SERIES**
**MECHANICAL DATA**

Case	Terminals	Polarity	Mounting Position	Weight per piece
JEDEC SOT-23 molded plastic body	Matte tin plated	Polarity symbol marking on case	Any	0.00019 Ounce, 0.00591 grams

**ABSOLUTE MAX. RATINGS AT Ta=25 °C (unless otherwise specified)**

Parameter	SYMBOLS	VALUE	UNITS
		LIMIT	
ESD per IEC 61000-4-2 (Air)	V ESD	+/-30	KV
ESD per IEC 61000-4-2 (Contact)	V ESD	+/-22	KV
ESD Voltage per human body model	ESD	16	KV
ESD Voltage per machine model	ESD	400	KV
Total Power Dissipation on FR-5 Board (Note 1) @ Ta=25°C	P D	150	mW
Operating Temperature Range	TOPT	-55 ~+ 150	°C
Storage Temperature Range	T STG	-55 ~ +150	°C
Lead Solder Temperature – Maximum (10 Second Duration)	T L	260 (10s)	°C

Note: :1. FR-5=1.0x0.75x0.62 in

**SMD ESD PROTECTION DIODES (TUBE) SOD-523 SERIES**
**RELIABILITY**

Number	Experiment Items	Experiment Method And Conditions	Reference Documents
1	Solder Resistance Test	Test 260°C± 5°C for 10 ± 2 sec. Immerse body into solder 1/16" ± 1/32"	MIL-STD-750D METHOD-2031.2
2	Solderability Test	230°C ±5°C for 5 sec.	MIL-STD-750D METHOD-2026.1 0
3	Pull Test	1 kg in axial lead direction for 10 sec.	MIL-STD-750D METHOD-2036.4
4	Bend Test	0.5Kg Weight Applied To Each Lead, Bending Arcs 90 °C ± 5 °C For 3 Times	MIL-STD-750D METHOD-2036.4
5	High Temperature Reverse Bias Test	TA=100°C for 1000 Hours at VR=80% Rated VR	MIL-STD-750D METHOD-1038.4
6	Forward Operation Life Test	TA=25°C Rated Average Rectified Current	MIL-STD-750D METHOD-1027.3
7	Intermittent Operation Life Test	On state: 5 min with rated IRMS Power Off state: 5 min with Cool Forced Air. On and off for 1000 cycles.	MIL-STD-750D METHOD-1036.3
8	Pressure Cooker Test	15 PSIG, TA=121°C, 4 hours	MIL-S-19500 APPENOIXC
9	Temperature Cycling Test	-55°C~+125°C; 30 Minutes For Dwelled Time 5 minutes for transferred time. Total: 10 cycles.	MIL-STD-750D METHOD-1051.7
10	Thermal Shock Test	0°C for 5 minutes., 100°C for 5minutes, Total: 10 cycles	MIL-STD-750D METHOD-1056.7
11	Forward Surge Test	8.3ms Single Sale Sine-wave One Surge.	MIL-STD-750D METHOD-4066.4
12	Humidity Test	TA=65°C, RH=98% for 1000 hours.	MIL-STD-750D METHOD-1021.3
13	High Temperature Storage life Test	150°C for 1000 Hours	MIL-STD-750D METHOD-1031.5

**SMD ESD PROTECTION DIODES (TUBE) SOD-523 SERIES**

**SUGGESTED REFLOW PROFILE (For Reference Only)**

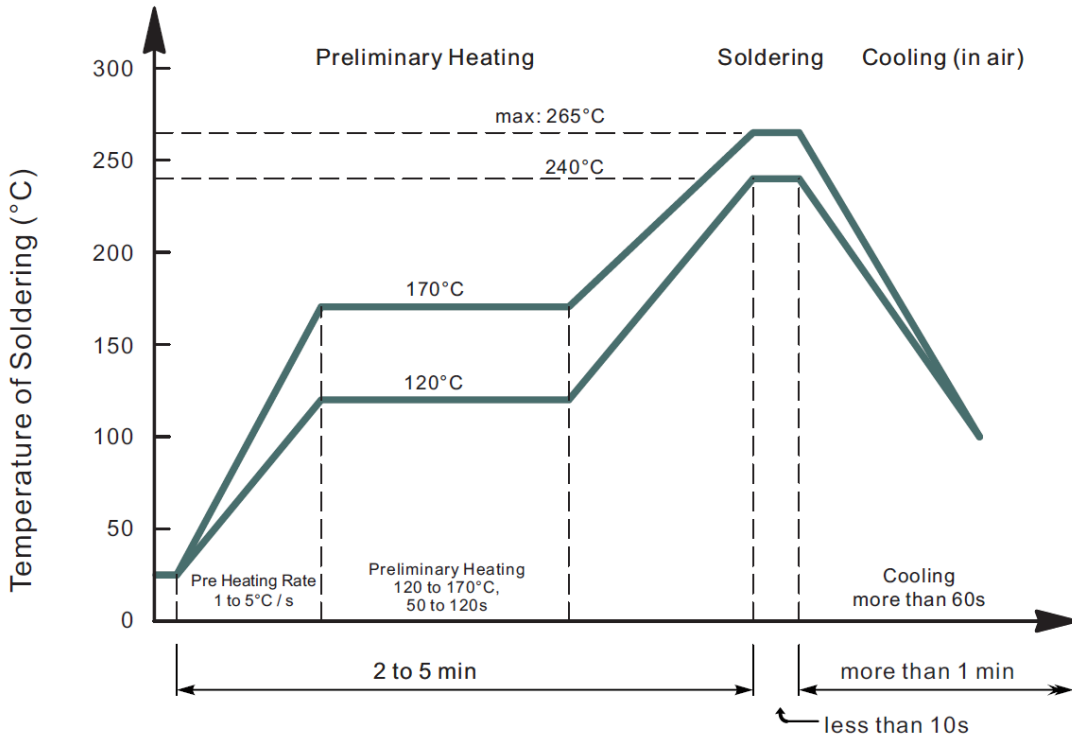

- Recommended peak temperature is over 245°C, If peak temperature is below 245 °C, you may adjust the following parameters; time length of peak temperature (longer), time length of soldering (longer), thickness of solder paste (thicker)
- Welding shall not exceed 2 times
- Remark: lead free solder paste (96.5 sn/3.0 Ag/0.5Cu)

**SMD ESD PROTECTION DIODES (TUBE) SOD-523 SERIES**

**RATINGS AND CHARACTERISTIC CURVES (For Reference Only)**

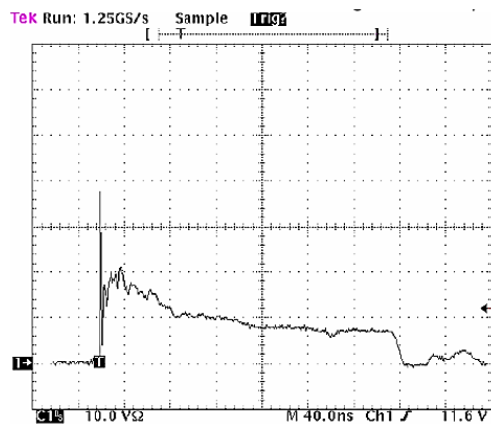

Figure 1. ESD Clamping Voltage Screenshot  
Positive 8 kV contact per IEC 61000-4-2

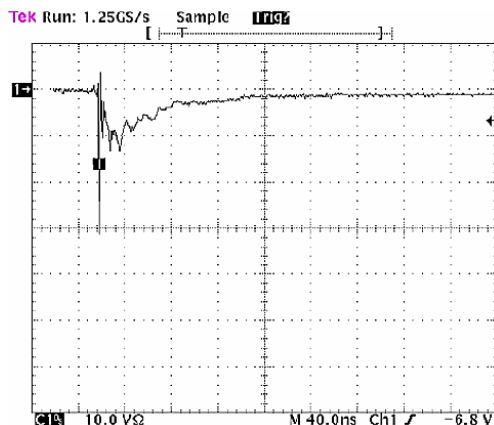
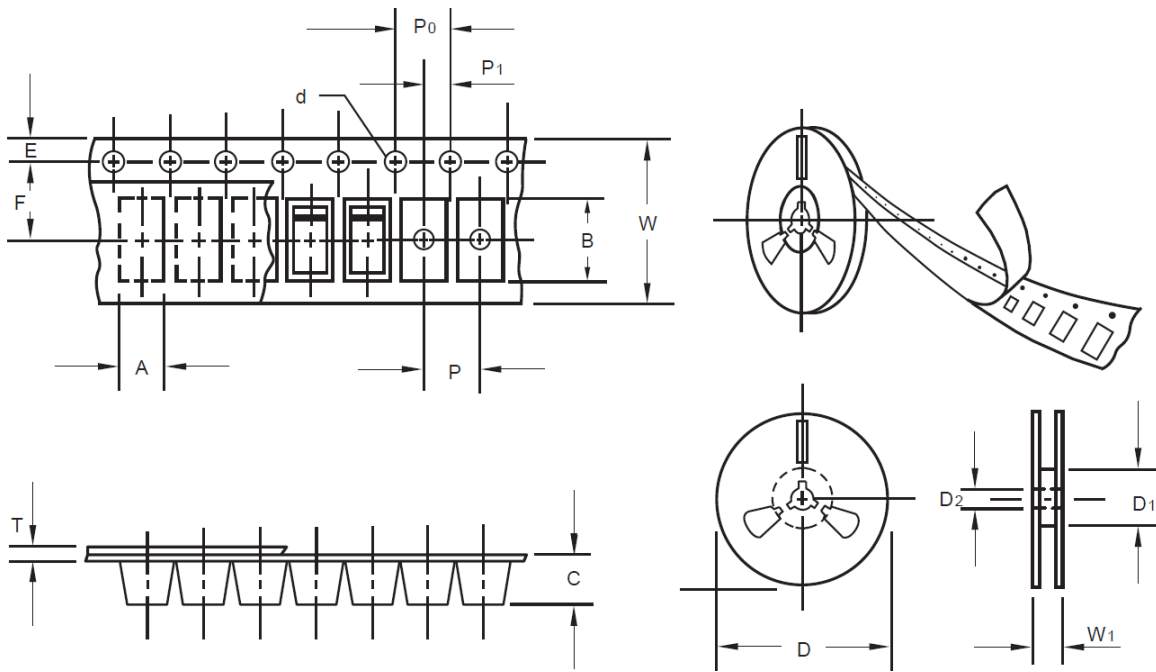

Figure 2. ESD Clamping Voltage Screenshot  
Negative 8 kV contact per IEC 61000-4-2

**SMD ESD PROTECTION DIODES (TUBE) SOD-523 SERIES**

**TAPE/REEL (Unit: mm)**

All Devices are packed in accordance with EIA standard RS-481-A and specifications.



Item	Symbol	Tolerance	SOD-523
Carrier width	A	0.1	2.10
Carrier Length	B	0.1	4.00
Carrier Depth	C	0.1	1.60
Sprocket hole	d	0.05	1.55
13" Reel outside diameter	-	-	-
13" Reel inner diameter	-	-	-
7" Reel outside diameter	D	2.0	178.00
7" Reel inner diameter	D1	Min.	50.00
Feed hole diameter	D2	0.5	13.00
Sprocket hole position	E	0.1	1.75
Punch hole position	F	0.1	3.50
Punch hole pitch	P	0.1	4.00
Sprocket hole pitch	P0	0.1	4.00
Embossment center	P1	0.1	2.00
Overall tape thickness	T	0.1	0.25
Tape width	W	0.3	8.15
Reel width	W1	1.0	10.50

**SMD ESD PROTECTION DIODES (TUBE) SOD-523 SERIES**

**PACKAGE**

Case Code	Reel Size	MPQ (pcs)	Component Spacing (mm)	Qty. Per Box (pcs)	Inner Box L*W*H (mm)	Reel Size (mm)	Carton size L*W*H (mm)	Qty. Per Carton (pcs)	G. W (kg)
SOD-523	7"	3,000		45,000	183*188*80	178	400*400*250	180,000	9

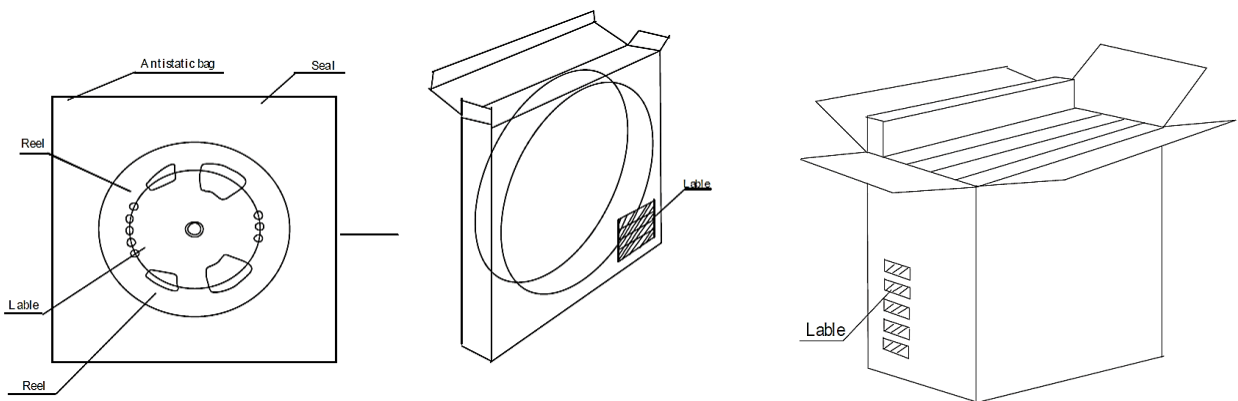

**DISCLAIMER**

NextGen Component, Inc. reserves the right to make changes to the product(s) and or information contained herein without notice. No liability is assumed as a result of their use or application. No rights under any patent accompany the sale of any such product(s) or information





## Looking for pricing, stock, or lifecycle information?

Click below to explore more details on WIN SOURCE:

 [View ESD5Z3V3 on WIN SOURCE](#)

 [MDD Information](#)

## Optimize Your Supply Chain with WIN SOURCE Solutions

-  Global Sourcing Solution
-  Obsolete Management
-  Cost Control Management
-  Shortage Management
-  Alternative Solution
-  Excess Inventory Management