



**THE DATASHEET OF
EFJ-N1695J5B**



Ceramic Resonators, Chip Type

Type: **JN** (16 to 50 MHz)

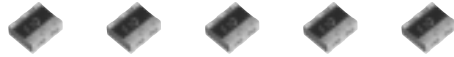

■ Features

- Low Profile Type (1.2 mm maximum in thickness)
- Designed for lead free soldering
- Wide Oscillation Frequency : 16 to 50 MHz
- High reliability against soldering heat and mechanical stress

■ Recommended Applications

- Clock generator for microprocessors
- Carrier between telecommunication equipment (Telephone to telephone, personal computer to printer)

■ Precautions for Safety (See Page 237 to 238)

■ Explanation of Part Numbers

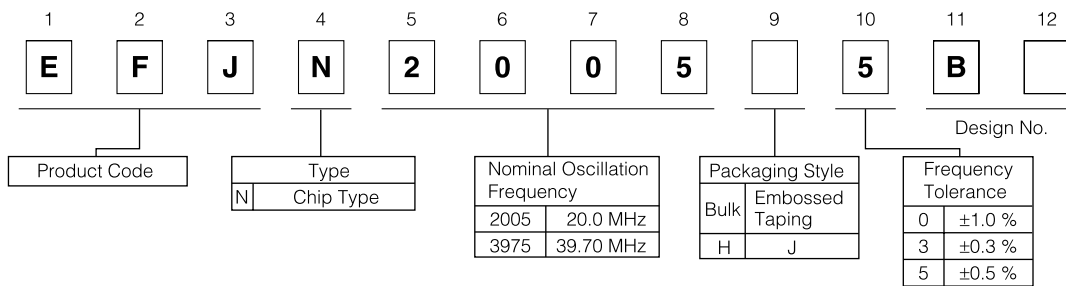

■ Ratings and Characteristics

Part Number		Oscillation Frequency (fo)	Loop Gain (G)	Weight (g)	Temperature Characteristics
Bulk Pack	Embossed Taping				
EFJN1695H5B	EFJN1695J5B	16.93 MHz ±0.5 %	14 dB min.	0.022	Maximum frequency drift: ±0.2 %, -20 to 80 °C
EFJN2005H5B	EFJN2005J5B	20.00 MHz ±0.5 %			
EFJN2505H5B	EFJN2505J5B	25.00 MHz ±0.5 %	10 dB min.		
EFJN3205H5B	EFJN3205J5B	32.00 MHz ±0.5 %			
EFJN3385H5B	EFJN3385J5B	33.868 MHz ±0.5 %			
EFJN4005H5B	EFJN4005J5B	40.00 MHz ±0.5 %			

- Operating Temperature Range: -20 to 80 °C
- Frequency Drift : 0.2% max./10 years

Note:
Also available are types other than above standard products in the frequency range of 16.0 to 50.0 MHz.

■ Dimensions in mm (not to scale)

● Bulk

[Type JN] EFJN□□□□H□B

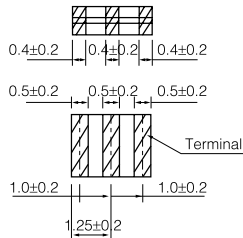
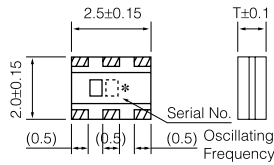

Thickness changes with Products
(40 MHz : 0.80 mm)

● Embossed Taping

[Type JN] EFJN□□□□J□B

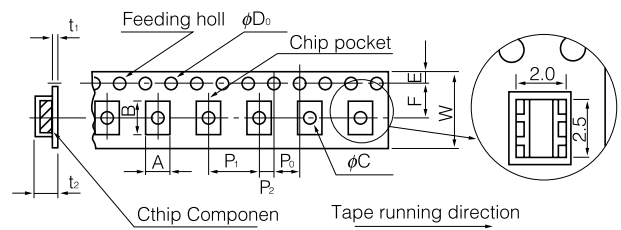

Dim. (mm)	A	B	W	F	E	P ₁
	2.3	2.8	8.0±0.2	3.5±0.1	1.75±0.1	4.0±0.1
Dim. (mm)	P ₂	P ₀	φD ₀	t ₁	t ₂	φC
	2.0±0.1	4.0±0.1	1.5 ^{+0.1}	0.35	1.65	1.0

■ Test Circuits Diagram

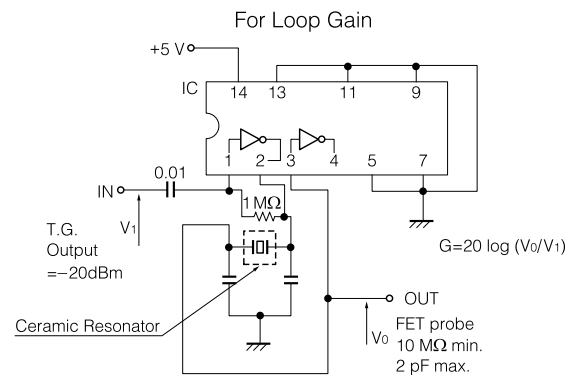
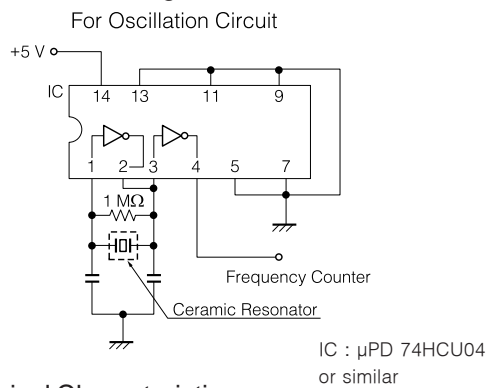

■ Typical Characteristics

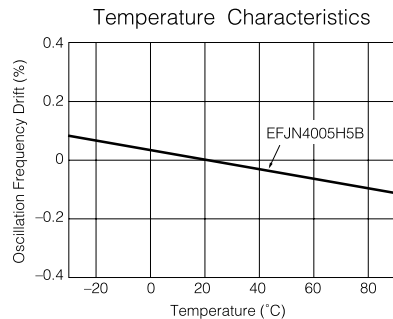

■ Recommended Land Dimensions

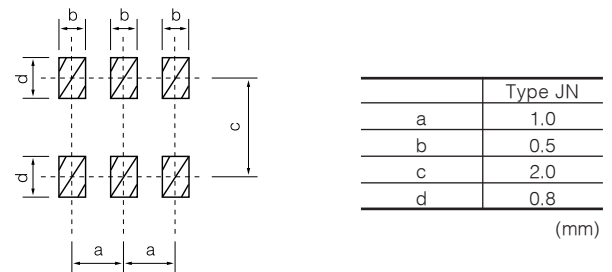

■ Packaging Specifications

Supplied in bulk or taped & reel packing style

● Standard Packing Quantity

Embossed Taping	Bulk
3000 pcs./reel	500 pcs./bag

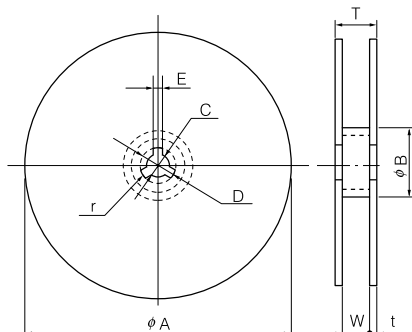

● Dimensions for Reel in mm (not to scale)



Dim. (mm)	φA	φB	C	D	E
	180±5	60 min.	13±0.2	21±0.8	2.0±0.5
Dim. (mm)	W	T	t	r	
	9.0 ^{+1.0} _{-0.5}	14.0 max.	2.5 max.	1.0	

Looking for pricing, stock, or lifecycle information?

Click below to explore more details on WIN SOURCE:

-  [View EFJ-N1695J5B on WIN SOURCE](#)
-  [Panasonic Information](#)

Optimize Your Supply Chain with WIN SOURCE Solutions

-  Global Sourcing Solution
-  Obsolete Management
-  Cost Control Management
-  Shortage Management
-  Alternative Solution
-  Excess Inventory Management