



**THE DATASHEET OF
EFC6604R-TR**



MOSFET – Power, for 1-Cell Lithium-ion Battery Protection, Dual N-Channel 12 V, 13 A, 9.0 mΩ EFC6604R

This Power MOSFET features a low on-state resistance. This device is suitable for applications such as power switches of portable machines. Best suited for 1-cell lithium-ion battery applications.

Features

- 2.5 V Drive
- 2 kV ESD HBM
- Common-Drain Type
- ESD Diode-Protected Gate
- This Device is Pb-Free, Halogen Free/BFR Free and is RoHS Compliant

Applications

- 1-Cell Lithium-ion Battery Charging and Discharging Switch

Specifications

ABSOLUTE MAXIMUM RATINGS (T_A = 25°C)

Parameter	Symbol	Value	Unit
Source-to-Source Voltage	V _{SSS}	12	V
Gate-to-Source Voltage	V _{GSS}	±12	V
Source Current (DC)	I _S	13	A
Source Current (Pulse) PW ≤ 10 μs, duty cycle ≤ 1%	I _{SP}	60	A
Total Dissipation (Note 1)	P _T	1.6	W
Junction Temperature	T _J	150	°C
Storage Temperature	T _{STG}	-55 to +150	°C

Stresses exceeding those listed in the Maximum Ratings table may damage the device. If any of these limits are exceeded, device functionality should not be assumed, damage may occur and reliability may be affected.

THERMAL RESISTANCE RATINGS

Parameter	Symbol	Value	Unit
Junction to Ambient (Note 1)	R _{θJA}	78.1	°C/W

1. Surface mounted on ceramic substrate (5000 mm² x 0.8 mm)

PIN ASSIGNMENT

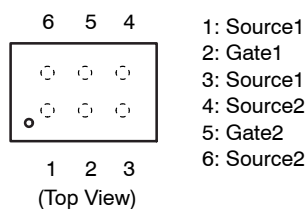

V _{SSS}	R _{SS(on)} Max	I _S Max
12 V	9.0 mΩ @ 4.5 V	13 A
	9.7 mΩ @ 4.0 V	
	10.0 mΩ @ 3.8 V	
	12.7 mΩ @ 3.1 V	
	17.7 mΩ @ 2.5 V	

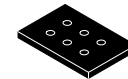

WLCSP6 1.91x1.46 / EFCP1915-6CE-020
CASE 614AC

MARKING DIAGRAM

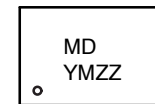

- MD = Specific Device Code
Y = Year of Production
M = Assembly Operation Month
ZZ = Assembly Lot Number

ELECTRICAL CONNECTION

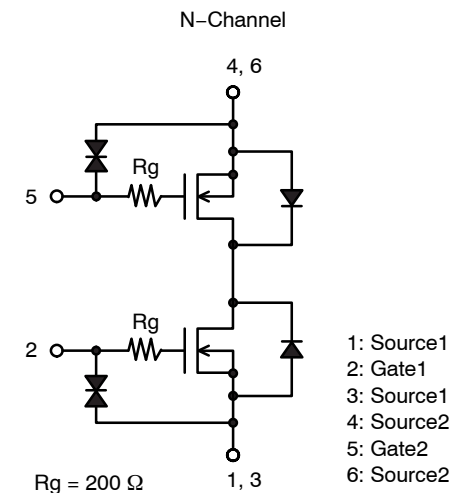

ORDERING INFORMATION

Device	Package	Shipping
EFC6604R-TR	WLCSP6 (Pb-Free and Halogen Free)	5000 / Tape & Reel

†For information on tape and reel specifications, including part orientation and tape sizes, please refer to our Tape and Reel Packaging Specifications Brochure, BRD8011/D.

ELECTRICAL CHARACTERISTICS (T_A = 25°C)

Parameter	Symbol	Conditions	Min	Typ	Max	Unit	
Source-to-Source Breakdown Voltage	V _{(BR)SSS}	I _S = 1 mA, V _{GS} = 0 V	Test Circuit 1	12	-	-	V
Zero-Gate Voltage Source Current	I _{SSS}	V _{SS} = 10 V, V _{GS} = 0 V	Test Circuit 1	-	-	1	μA
Gate-to-Source Leakage Current	I _{GSS}	V _{GS} = ±8 V, V _{SS} = 0 V	Test Circuit 2	-	-	±1.0	μA
Gate Threshold Voltage	V _{GS(th)}	V _{SS} = 6 V, I _S = 1 mA	Test Circuit 3	0.5	-	1.3	V
Forward Transconductance	g _{FS}	V _{SS} = 6 V, I _S = 3 A	Test Circuit 4	-	13.7	-	S
Static Source-to-Source On-State Resistance	R _{SS(on)1}	I _S = 3 A, V _{GS} = 4.5 V	Test Circuit 5	6.0	7.5	9.0	mΩ
	R _{SS(on)2}	I _S = 3 A, V _{GS} = 4.0 V	Test Circuit 5	6.4	8.1	9.7	mΩ
	R _{SS(on)3}	I _S = 3 A, V _{GS} = 3.8 V	Test Circuit 5	6.7	8.4	10.0	mΩ
	R _{SS(on)4}	I _S = 3 A, V _{GS} = 3.1 V	Test Circuit 5	7.8	9.8	12.7	mΩ
	R _{SS(on)5}	I _S = 3 A, V _{GS} = 2.5 V	Test Circuit 5	10.0	12.6	17.7	mΩ
Turn-ON Delay Time	t _{d(on)}	V _{SS} = 6 V, V _{GS} = 4.5 V, I _S = 3 A	Test Circuit 6	-	300	-	ns
Rise Time	t _r			-	1200	-	ns
Turn-OFF Delay Time	t _{d(off)}			-	5200	-	ns
Fall Time	t _f			-	3900	-	ns
Total Gate Charge	Q _g	V _{SS} = 6 V, V _{GS} = 4.5 V, I _S = 13 A	Test Circuit 7	-	29	-	nC
Forward Source-to-Source Voltage	V _{F(S-S)}	I _S = 3 A, V _{GS} = 0 V	Test Circuit 8	-	0.75	1.2	V

Product parametric performance is indicated in the Electrical Characteristics for the listed test conditions, unless otherwise noted. Product performance may not be indicated by the Electrical Characteristics if operated under different conditions.

Test circuits are example of measuring FET1 side.

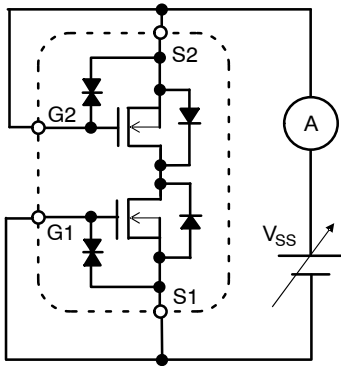

Figure 1. Test Circuit 1 - V_{SSS} / I_{SSS}

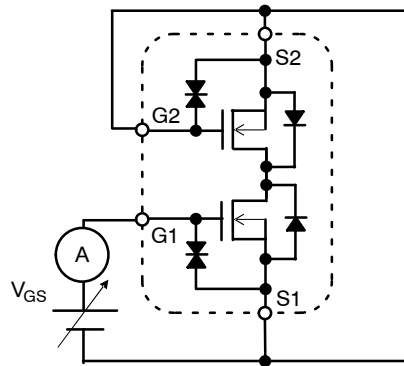

Figure 2. Test Circuit 2 - I_{GSS}

When FET1 is measured, Gate and Source of FET2 are short-circuited.

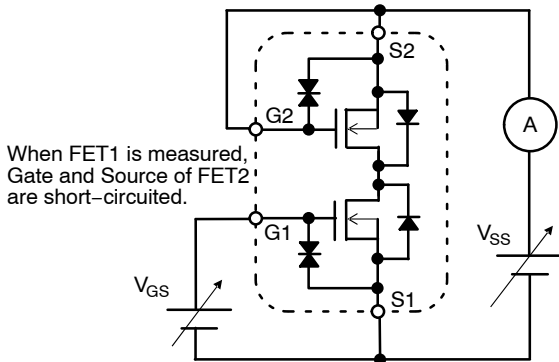

Figure 3. Test Circuit 3 - V_{GS(th)}

When FET1 is measured, Gate and Source of FET2 are short-circuited.

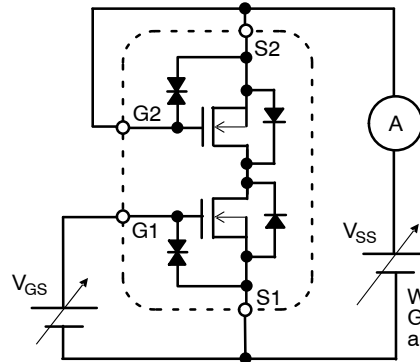

Figure 4. Test Circuit 4 - g_{FS}

When FET1 is measured, Gate and Source of FET2 are short-circuited.

TEST CIRCUITS (continued)

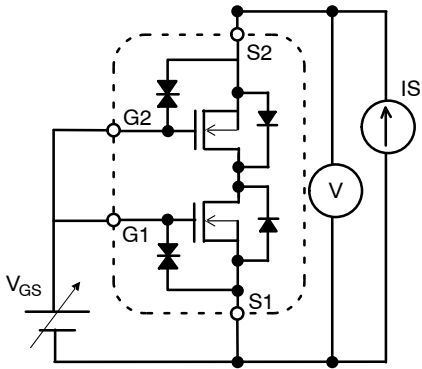

Figure 5. Test Circuit 5 - $R_{SS(on)}$

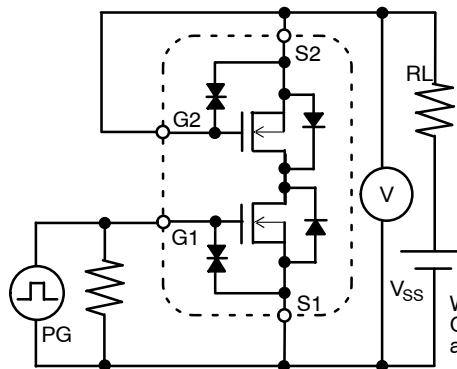

Figure 6. Test Circuit 6 - $t_{d(on)}$, t_r , $t_{d(off)}$, t_f

When FET1 is measured, Gate and Source of FET2 are short-circuited.

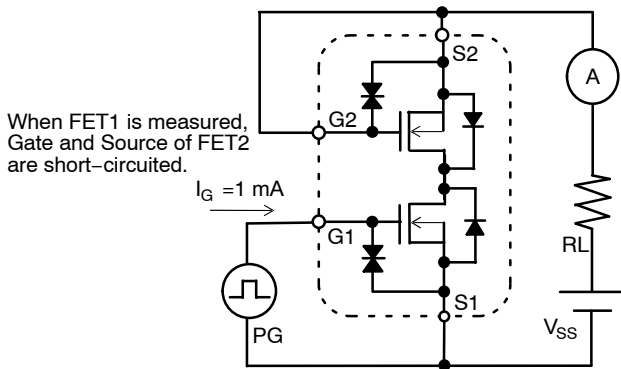

Figure 7. Test Circuit 7 - Q_g

When FET1 is measured, Gate and Source of FET2 are short-circuited.

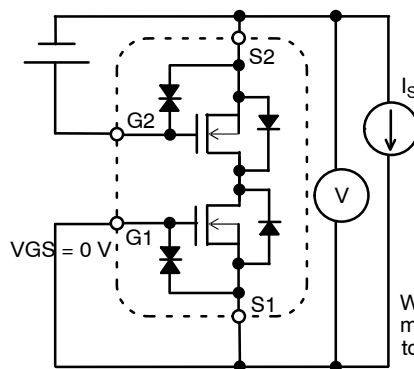

Figure 8. Test Circuit 8 - $V_{F(S-S)}$

When FET1 is measured, +4.5 V is added to V_{GS} of FET2.

When FET2 is measured, the position of FET1 and FET2 is switched.

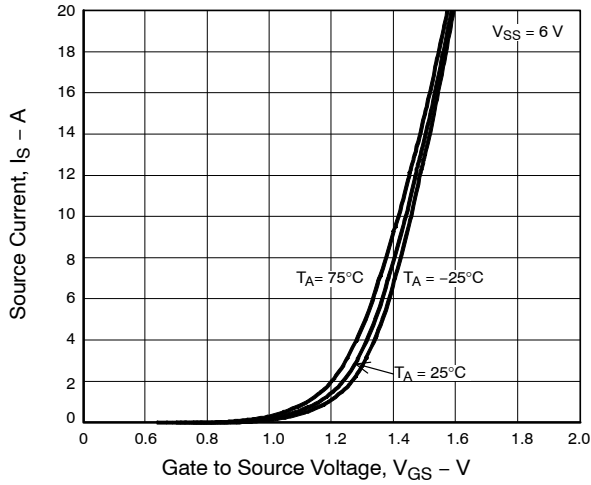

Figure 9. $I_S - V_{GS}$

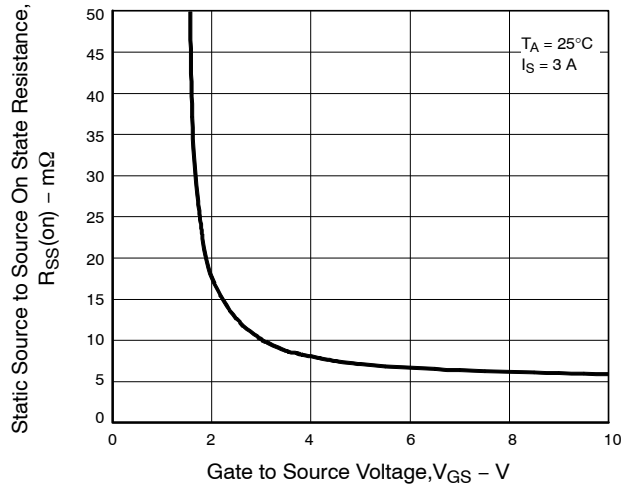

Figure 10. $R_{SS(on)} - V_{GS}$

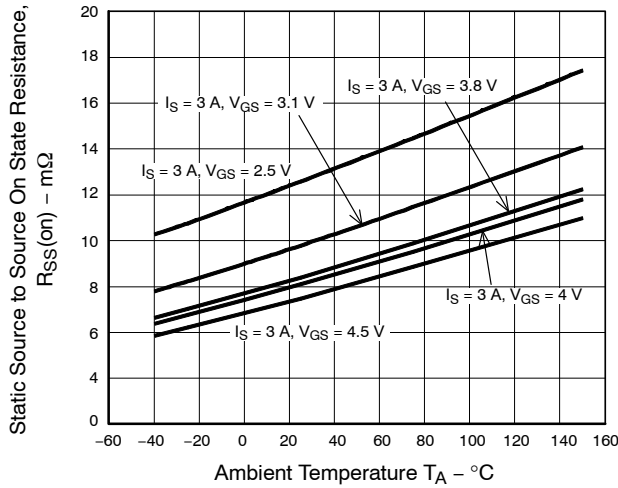

Figure 11. $R_{SS(on)} - T_A$

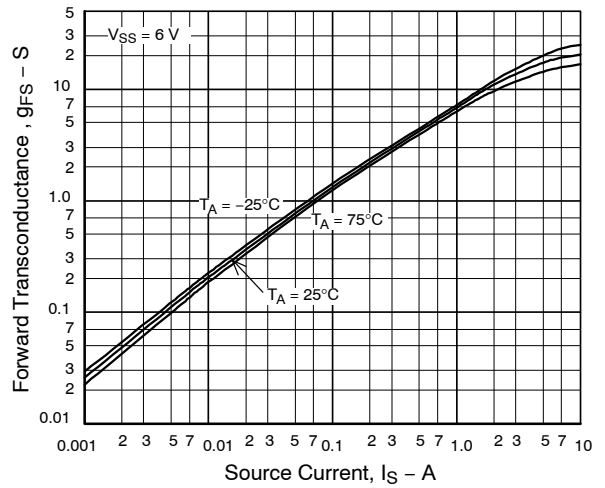

Figure 12. $g_{FS} - I_S$

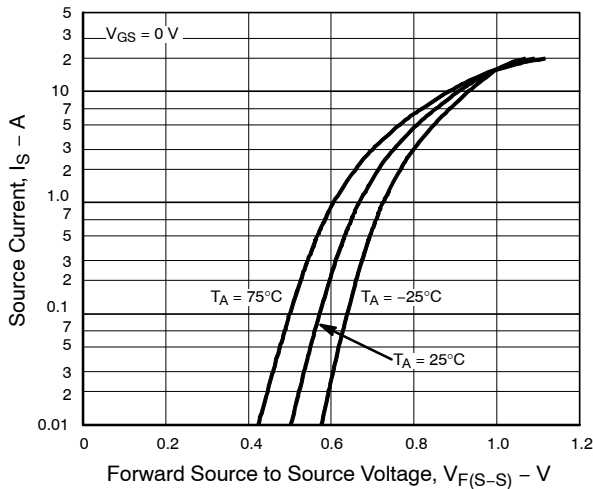

Figure 13. $I_S - V_{F(S-S)}$

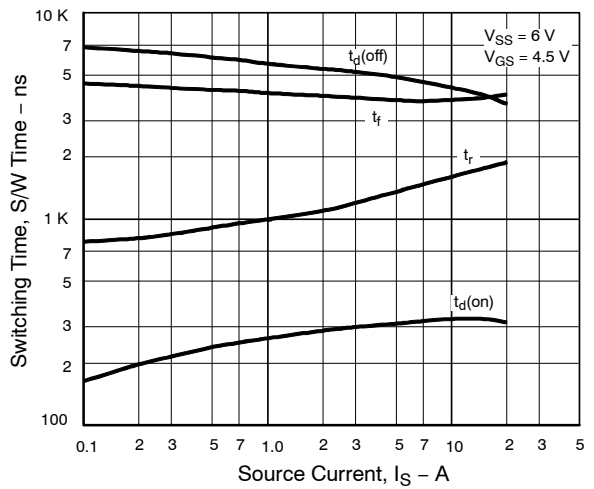

Figure 14. S/W Time - I_S

EFC6604R

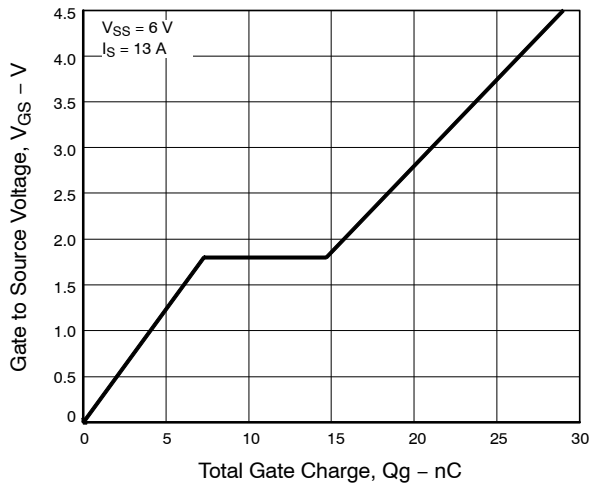

Figure 15. $V_{GS} - Q_g$

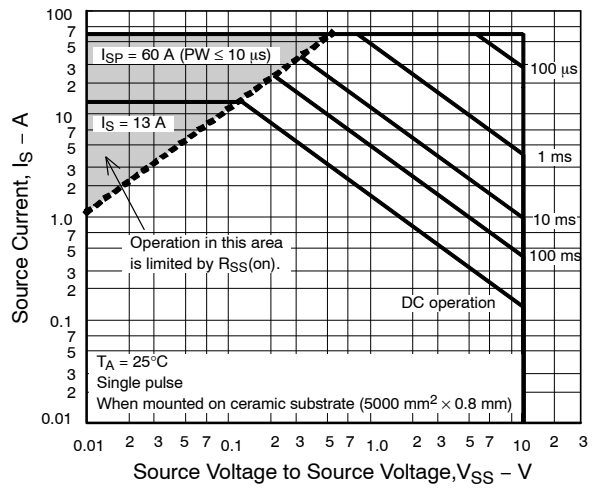

Figure 16. SOA

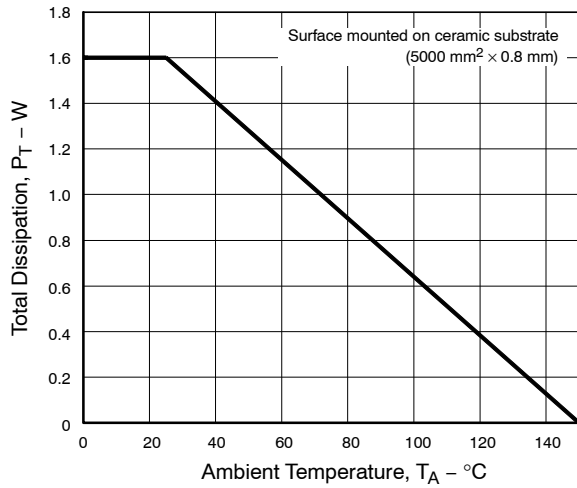

Figure 17. $P_T - T_A$

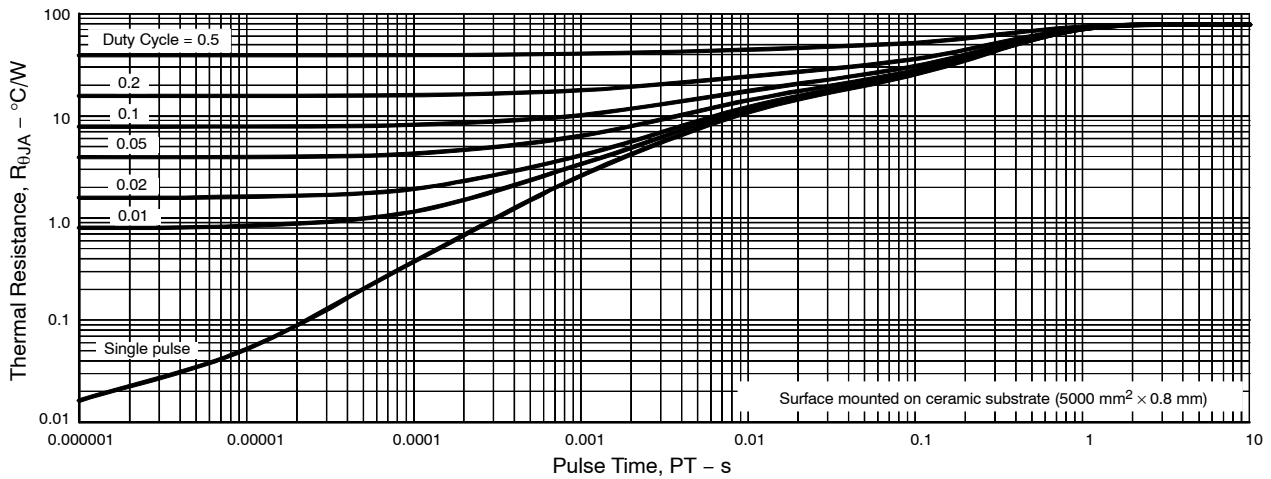

Figure 18. $R_{\theta JA} - \text{Pulse Time}$

Note on usage: Since the EFC6604R is a MOSFET product, please avoid using this device in the vicinity of highly charged objects. Please contact sales for use except the designated application.

MECHANICAL CASE OUTLINE

PACKAGE DIMENSIONS

ON Semiconductor®



SCALE 4:1

WLCSP6 1.91x1.46 / EFCP1915-6CE-020
CASE 614AC
ISSUE B

DATE 09 JAN 2015

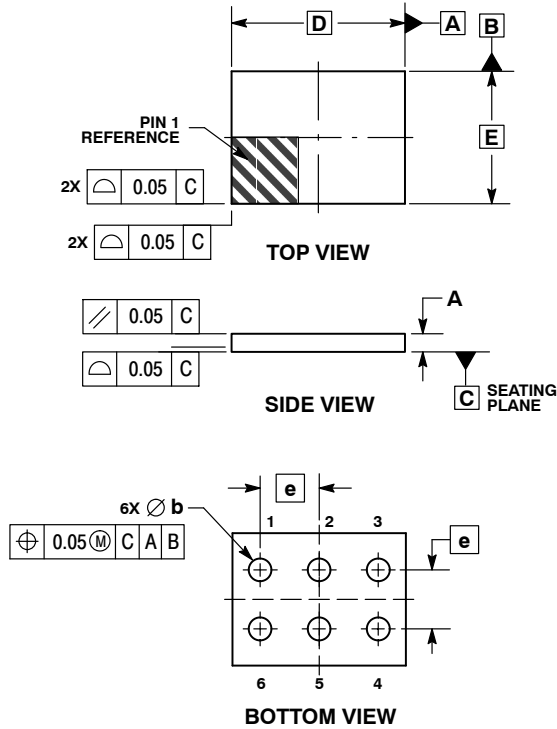

- NOTES:
1. DIMENSIONING AND TOLERANCING PER ASME Y14.5M, 1994.
 2. CONTROLLING DIMENSION: MILLIMETERS.

DIM	MILLIMETERS	
	MIN	MAX
A	0.18	0.22
b	0.27	0.33
D	1.91 BSC	
E	1.46 BSC	
e	0.65 BSC	

RECOMMENDED SOLDERING FOOTPRINT*

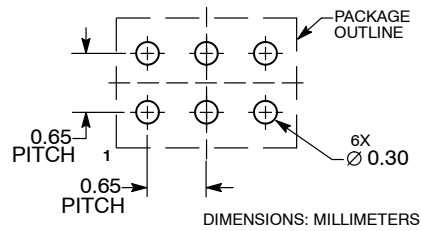

*For additional information on our Pb-Free strategy and soldering details, please download the ON Semiconductor Soldering and Mounting Techniques Reference Manual, SOLDERRM/D.

DOCUMENT NUMBER:	98AON89490E	Electronic versions are uncontrolled except when accessed directly from the Document Repository. Printed versions are uncontrolled except when stamped "CONTROLLED COPY" in red.
DESCRIPTION:	WLCSP6 1.91X1.46 / EFCP1915-6CE-020	PAGE 1 OF 1

ON Semiconductor and are trademarks of Semiconductor Components Industries, LLC dba ON Semiconductor or its subsidiaries in the United States and/or other countries. ON Semiconductor reserves the right to make changes without further notice to any products herein. ON Semiconductor makes no warranty, representation or guarantee regarding the suitability of its products for any particular purpose, nor does ON Semiconductor assume any liability arising out of the application or use of any product or circuit, and specifically disclaims any and all liability, including without limitation special, consequential or incidental damages. ON Semiconductor does not convey any license under its patent rights nor the rights of others.

onsemi, **Onsemi**, and other names, marks, and brands are registered and/or common law trademarks of Semiconductor Components Industries, LLC dba "**onsemi**" or its affiliates and/or subsidiaries in the United States and/or other countries. **onsemi** owns the rights to a number of patents, trademarks, copyrights, trade secrets, and other intellectual property. A listing of **onsemi**'s product/patent coverage may be accessed at www.onsemi.com/site/pdf/Patent-Marking.pdf. **onsemi** reserves the right to make changes at any time to any products or information herein, without notice. The information herein is provided "as-is" and **onsemi** makes no warranty, representation or guarantee regarding the accuracy of the information, product features, availability, functionality, or suitability of its products for any particular purpose, nor does **onsemi** assume any liability arising out of the application or use of any product or circuit, and specifically disclaims any and all liability, including without limitation special, consequential or incidental damages. Buyer is responsible for its products and applications using **onsemi** products, including compliance with all laws, regulations and safety requirements or standards, regardless of any support or applications information provided by **onsemi**. "Typical" parameters which may be provided in **onsemi** data sheets and/or specifications can and do vary in different applications and actual performance may vary over time. All operating parameters, including "Typicals" must be validated for each customer application by customer's technical experts. **onsemi** does not convey any license under any of its intellectual property rights nor the rights of others. **onsemi** products are not designed, intended, or authorized for use as a critical component in life support systems or any FDA Class 3 medical devices or medical devices with a same or similar classification in a foreign jurisdiction or any devices intended for implantation in the human body. Should Buyer purchase or use **onsemi** products for any such unintended or unauthorized application, Buyer shall indemnify and hold **onsemi** and its officers, employees, subsidiaries, affiliates, and distributors harmless against all claims, costs, damages, and expenses, and reasonable attorney fees arising out of, directly or indirectly, any claim of personal injury or death associated with such unintended or unauthorized use, even if such claim alleges that **onsemi** was negligent regarding the design or manufacture of the part. **onsemi** is an Equal Opportunity/Affirmative Action Employer. This literature is subject to all applicable copyright laws and is not for resale in any manner.

ADDITIONAL INFORMATION

TECHNICAL PUBLICATIONS:

Technical Library: www.onsemi.com/design/resources/technical-documentation
onsemi Website: www.onsemi.com

ONLINE SUPPORT: www.onsemi.com/support

For additional information, please contact your local Sales Representative at www.onsemi.com/support/sales

Looking for pricing, stock, or lifecycle information?

Click below to explore more details on WIN SOURCE:

 [View EFC6604R-TR on WIN SOURCE](#)

 [ON Semiconductor](#) Information

Optimize Your Supply Chain with WIN SOURCE Solutions

-  Global Sourcing Solution
-  Obsolete Management
-  Cost Control Management
-  Shortage Management
-  Alternative Solution
-  Excess Inventory Management