



**THE DATASHEET OF
BBT3821-JH**



BBT3821

Octal 2.488Gbps to 3.187Gbps/Lane Retimer

FN7483
Rev.1.00
July 20, 2005

Features

- 8 Lanes of Clock & Data Recovery and Retiming; 4 in Each Direction
- Differential Input/Output
- Wide Operating Data Rate Range: 2.488Gbps to 3.1875Gbps, and 1.244Gbps to 1.59325Gbps
- Ultra Low-Power Operation (195mW typical per lane, 1550mW typical total consumption)
- Low Power Version Available for LX4 Applications
- 17mm Square Low Profile 192 pin 1.0mm Pitch EPGA Package
- Compliant to the IEEE 802.3 10GBASE-LX4(WWDM), 10GBASE-CX4, and XAUI Specifications
- Reset Jitter Domain
- Meets 802.3ae and 802.3ak Jitter Requirements with Significant Margin
- Received Data Aligned to Local Reference Clock for Retransmission
- Increase Driving Distance
- LX4: Up to 40 inches of FR-4 Traces or 500 Meters of MMF Fiber at 3.1875Gbps
- CX4: Over 15 meters of Compatible Cable
- Deskewing and Lane-to-Lane Alignment
- 0.13mm Pure-Digital CMOS Technology
- 1.5V Core Supply, Control I/O 2.5V Tolerant
- Clock Compensation
- Tx/Rx Rate Matching via IDLE Insertion/Deletion up to ± 100 ppm Clock Difference
- Receive Signal Detect and 16 Levels of Receiver Equalization for Media Compensation
- CML CX4 Transmission Output with 16 Settable Levels of Pre-Emphasis, Eight on XAUI Side
- Single-Ended or Differential Input Lower-Speed Reference Clock
- Ease of Testing
- Complete Suite of Ingress-Egress Loopbacks
- Full 802.3ae Pattern Generation and Test, including CJPAT & CRPAT
- PRBS (both $2^{23}-1$ and 13458 byte) Built-In Self Tests, Error Flags and Count Output
- JTAG and AC-JTAG Boundary Scan
- Long Run Length (512 bit) Frequency Lock Ideal for Proprietary Encoding Schemes
- Extensive Configuration and Status Reporting via 802.3 Clause 45 Compliant MDC/MDIO Serial Interface
- Automatic Load of BBT3821 Control and all XENPAK Registers from EEPROM or DOM Circuit

FIGURE 1. FUNCTIONAL BLOCK DIAGRAM

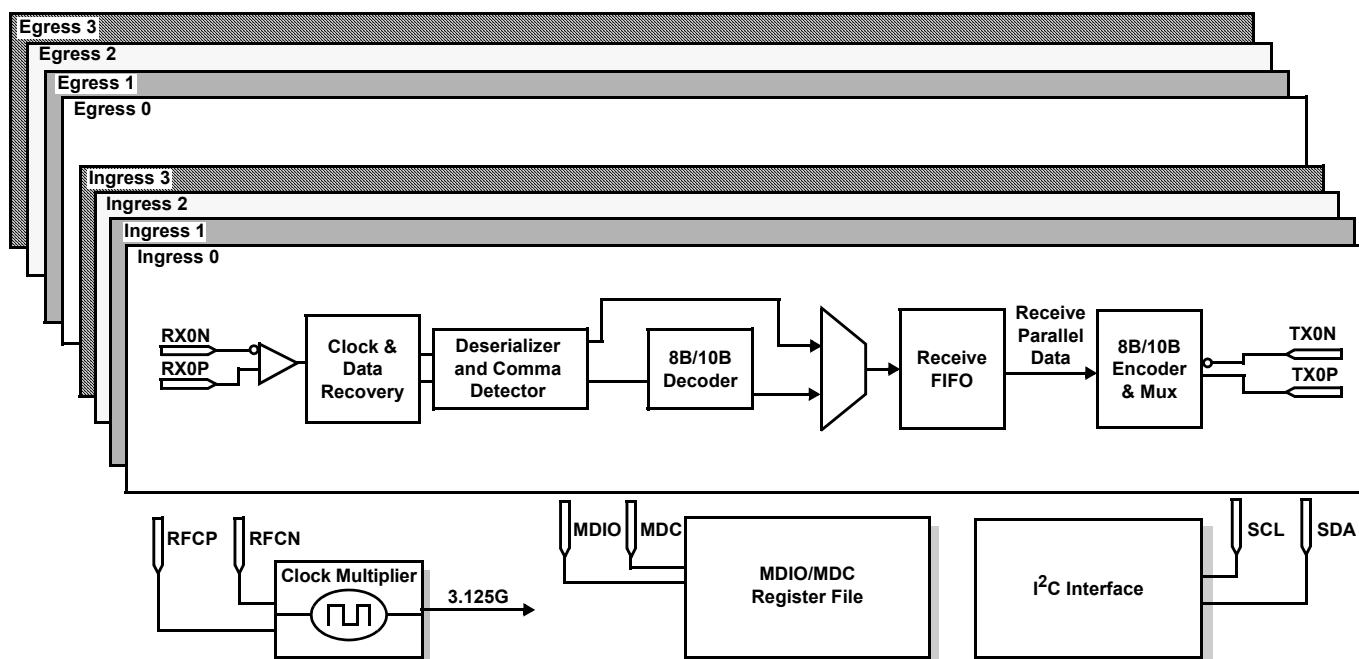

Table of Contents

Features	1
Table of Contents	2
List of Figures	4
List of Tables	5
General Description	9
Functions	9
Receiver Operations	9
Loss of Signal Detection, Termination & Equalization	9
Clock and Data Recovery	10
Byte Alignment (Code-Group Alignment)	10
8b/10b Decoding	10
Receive FIFO	10
Deskew (Lane to Lane) Alignment	10
Clock Compensation	11
Transmitter Operations	11
8b/10b Encoding	11
Pre-Emphasis	11
8b/10b Coding and Decoding	12
8 Bit Mode	12
10 Bit Mode	13
Error Indications	13
Loss of Signal	13
Byte or Lane Synchronization Failure	13
Channel Fault Indications	13
Coding Violation, Disparity & FIFO Errors	13
Loopback Modes	13
PMA Loopback (1.0.0 & 1.C004.[11:8])	13
PHY XS (Serial) Loopback (4.0.14 & 4.C004.[11:8])	14
PCS Parallel Network Loopback (3.C004.[3:0])	14
PCS (Parallel) Loopback (4.C004.[3:0] & Optionally 3.0.14)	14
Serial Test Loopbacks (1.C004.12 & 4.C004.12)	15
Serial Management Interface	15
MDIO Register Addressing	15
I2C Space Interface	16
NVR Registers & EEPROM	16
Auto-Configuring Control Registers	16
DOM Registers	16
General Purpose (GPIO) Pins	17
LASI Registers & I/O	17
Reading Additional EEPROM Space Via the I2C Interface	17
Writing EEPROM Space through the I2C Interface	19

Block Writes to EEPROM Space	19
Byte Writes to EEPROM Space	19
MDIO Registers	19
PMA/PMD DEVICE 1 MDIO REGISTERS	19
IEEE PMA/PMD Registers (1.0 to 1.15/1.000F'h)	21
XENPAK-Defined Registers (1.8000'h to 1.8106'h)	24
XENPAK LASI and DOM Registers (1.9000'h to 1.9007'h & 1.A000'h to 1.A100'h)	27
Vendor-Specific PMA/PMD and GPIO Registers (1.C001'h to 1.C01D'h)	33
PCS DEVICE 3 MDIO REGISTERS	38
IEEE PCS Registers (3.0 to 3.25/3.0019'h)	39
Vendor-Specific PCS Registers (3.C000'h to 3.C00E'h)	41
PHY XS DEVICE 4 MDIO REGISTERS	45
IEEE PHY XS Registers (4.0 to 4.25/4.0019'h)	46
Vendor-Specific PHY XS Registers (4.C000'h to 4.C00B'h)	47
Auto-Configure Register List	51
JTAG & AC-JTAG Operations	53
BIST Operation	53
Pin Specifications	55
Pin Diagram 17x17mm (16*16 Ball Matrix) 192-pin EBGA-B Package	58
Package Dimensions	59
Electrical Characteristics	60
Absolute Maximum Ratings	60
Operating Conditions	60
DC Characteristics	61
AC and Timing Characteristics	63
Timing Diagrams	65
Applications Information	70
CX4/LX4/XAUI Re-timer Setup	70
Recommended Analog Power and Ground Plane Splits	70
Recommended Power Supply Decoupling	71
XENPAK/XPAK/X2 Interfacing	71
CX4 Interfacing	72
LX4 Interfacing	72
MDIO/MDC Interfacing	72
I2C Interfacing	72
DOM Interfacing	72
LASI Interface	73
Ordering Information	75
Intersil Corporation Contact Information	75

List of Figures

Figure 1. FUNCTIONAL BLOCK DIAGRAM	1
Figure 2. DETAILED FUNCTIONAL BLOCK DIAGRAM (BIST OMITTED)	8
Figure 3. PRE-EMPHASIS OUTPUT ILLUSTRATION	11
Figure 4. IEEE AND VENDOR SPECIFIC FAULT AND STATUS REGISTERS (EQUIVALENT SCHEMATIC)	14
Figure 5. LASI EQUIVALENT SCHEMATIC	18
Figure 6. BLOCK DIAGRAM OF BIST OPERATION	54
Figure 7. TOP VIEW OF PINOUT	58
Figure 8. EBGA-192 PACKAGE DIMENSIONS	59
Figure 9. DIFFERENTIAL OUTPUT SIGNAL TIMING	65
Figure 10. LANE TO LANE DIFFERENTIAL SKEW	65
Figure 11. EYE DIAGRAM DEFINITION	65
Figure 12. BYTE SYNCHRONIZATION	66
Figure 13. LANE-LANE ALIGNMENT OPERATION	66
Figure 14. RETRANSMIT LATENCY	66
Figure 15. MDIO FRAME AND REGISTER TIMING	67
Figure 16. MDIO INTERFACE TIMING	67
Figure 17. MDIO TIMING AFTER SOFT RESET (D.0.15)	68
Figure 18. BEGINNING I2C NVR READ AT THE END OF RESET	68
Figure 19. I2C BUS INTERFACE PROTOCOL	68
Figure 20. NVR/DOM SEQUENTIAL READ OPERATION	69
Figure 21. NVR SEQUENTIAL WRITE ONE PAGE OPERATION	69
Figure 22. I2C SINGLE BYTE READ OPERATION	69
Figure 23. SINGLE BYTE WRITE OPERATION	69
Figure 24. I2C OPERATION TIMING	70
Figure 25. VDDPR CLAMP CIRCUIT	74
Figure 26. RESISTIVE DIVIDER CIRCUITS	74

List of Tables

Table 1. VALID 10b/8b DECODER & ENCODER PATTERNS.	12
Table 2. DEVAD DEVICE ADDRESS TABLE.	15
Table 3. MDIO MANAGEMENT FRAME FORMATS.	15
Table 4. MDIO PMA/PMD DEVAD 1 REGISTERS.	19
Table 5. IEEE PMA/PMD CONTROL 1 REGISTER.	21
Table 6. IEEE PMA/PMD STATUS 1 REGISTER.	21
Table 7. IEEE PMA/PMD, PCS, PHY XS, SPEED ABILITY REGISTER.	21
Table 8. IEEE DEVICES IN PACKAGE REGISTERS.	22
Table 9. IEEE PMA/PMD TYPE SELECT REGISTER.	22
Table 10. IEEE PMA/PMD STATUS 2 DEVICE PRESENT & FAULT SUMMARY REGISTER.	22
Table 11. IEEE TRANSMIT DISABLE REGISTER.	23
Table 12. IEEE PMD SIGNAL DETECT REGISTER.	23
Table 13. IEEE EXTENDED PMA/PMD CAPABILITY REGISTER(1).	23
Table 14. IEEE PACKAGE IDENTIFIER REGISTERS.	24
Table 15. XENPAK NVR CONTROL & STATUS REGISTER.	24
Table 16. I2C ONE-BYTE OPERATION DEVICE ADDRESS REGISTER.	24
Table 17. I2C ONE-BYTE OPERATION MEMORY ADDRESS REGISTER.	24
Table 18. I2C ONE-BYTE OPERATION READ DATA REGISTER.	24
Table 19. I2C ONE-BYTE OPERATION WRITE DATA REGISTER.	25
Table 20. NVR I2C OPERATION CONTROL REGISTER.	25
Table 21. NVR I2C OPERATION STATUS REGISTER.	25
Table 22. XENPAK NVR REGISTER COPY.	26
Table 23. XENPAK DIGITAL OPTICAL MONITORING (DOM) CAPABILITY REGISTER.	26
Table 24. XENPAK LASI RX_ALARM CONTROL REGISTER.	27
Table 25. XENPAK LASI TX_ALARM CONTROL REGISTER.	27
Table 26. XENPAK LASI CONTROL REGISTER.	27
Table 27. XENPAK LASI RX_ALARM STATUS REGISTER.	28
Table 28. XENPAK LASI TX_ALARM STATUS REGISTER.	28
Table 29. XENPAK LASI STATUS REGISTER.	29
Table 30. XENPAK DOM TX_FLAG CONTROL REGISTER.	29
Table 31. XENPAK DOM RX_FLAG CONTROL REGISTER.	29
Table 32. XENPAK DOM ALARM & WARNING THRESHOLD REGISTERS COPY.	30
Table 33. XENPAK DOM MONITORED A/D VALUES REGISTER COPY.	30
Table 34. XENPAK OPTIONAL DOM STATUS BITS REGISTER.	31
Table 35. XENPAK DOM EXTENDED CAPABILITY REGISTER.	32
Table 36. XENPAK DOM ALARM FLAGS REGISTER.	32
Table 37. XENPAK DOM WARNING FLAGS REGISTER.	32
Table 38. XENPAK DOM OPERATION CONTROL AND STATUS REGISTER.	33
Table 39. PMA CONTROL 2 REGISTER.	33
Table 40. PMA SERIAL LOOP BACK CONTROL REGISTER.	34
Table 41. PMA PRE-EMPHASIS CONTROL.	34
Table 42. PMA PRE-EMPHASIS CONTROL SETTINGS.	34
Table 43. PMA/PMD EQUALIZATION CONTROL.	35
Table 44. PMA SIG_DET AND LOS DETECTOR STATUS REGISTER.	35
Table 45. PMA/PMD MISCELLANEOUS ADJUSTMENT REGISTER.	35
Table 46. PMA/PMD/PCS/PHY XS SOFT RESET REGISTER.	35

Table 47. GPIO PIN DIRECTION CONFIGURE REGISTER	36
Table 48. GPIO PIN INPUT STATUS REGISTER	36
Table 49. TX_FAULT & GPIO PIN TO LASI CONFIGURE REGISTER	36
Table 50. GPIO PIN OUTPUT REGISTER	36
Table 51. DOM CONTROL REGISTER	37
Table 52. DOM PERIODIC UPDATE WAITING TIME VALUES	37
Table 53. DOM INDIRECT MODE START ADDRESS REGISTERS	37
Table 54. DOM INDIRECT MODE DEVICE ADDRESS REGISTERS	37
Table 55. OPTICAL STATUS & CONTROL PIN POLARITY REGISTER	38
Table 56. MDIO PCS DEVAD 3 REGISTERS	38
Table 57. IEEE PCS CONTROL 1 REGISTER	39
Table 58. IEEE PCS STATUS 1 REGISTER	39
Table 59. IEEE PCS TYPE SELECT REGISTER	39
Table 60. IEEE PCS STATUS 2 DEVICE PRESENT & FAULT SUMMARY REGISTER	40
Table 61. IEEE 10GBASE-X PCS STATUS REGISTER	40
Table 62. IEEE 10GBASE-X PCS TEST CONTROL REGISTER	40
Table 63. PCS CONTROL REGISTER 2	41
Table 64. PCS CONTROL REGISTER 3	41
Table 65. PCS or PHY XS XAUI_EN CONTROL OVERRIDE FUNCTIONS	42
Table 66. PCS INTERNAL ERROR CODE REGISTER	42
Table 67. PCS INTERNAL IDLE CODE REGISTER	42
Table 68. PCS PARALLEL NETWORK LOOP BACK CONTROL REGISTER	43
Table 69. PCS RECEIVE PATH TEST AND STATUS FLAGS	43
Table 70. PMA/PCS OUTPUT CONTROL & TEST FUNCTION REGISTER	43
Table 71. PCS/PHY XS HALF RATE CLOCK CONTROL REGISTER	44
Table 72. BIST CONTROL REGISTER	44
Table 73. BIST ERROR COUNTER REGISTERS	45
Table 74. MDIO PHY XS DEVAD 4 REGISTERS	45
Table 75. IEEE PHY XS CONTROL 1 REGISTER	46
Table 76. IEEE PHY XS STATUS 1 REGISTER	46
Table 77. IEEE PHY XS STATUS 2 DEVICE PRESENT & FAULT SUMMARY REGISTER	46
Table 78. IEEE 10GBASE-X PHY XGXS STATUS REGISTER	47
Table 79. IEEE 10GBASE-X PHY XGXS TEST CONTROL REGISTER	47
Table 80. PHY XS CONTROL REGISTER 2	47
Table 81. PHY XS CONTROL REGISTER 3	48
Table 82. PHY XS INTERNAL ERROR CODE REGISTER	49
Table 83. PHY XS INTERNAL IDLE CODE REGISTER	49
Table 84. PHY XS MISCELLANEOUS LOOP BACK CONTROL REGISTER	49
Table 85. PHY XS PRE-EMPHASIS CONTROL	50
Table 86. PHY XS XAUI PRE-EMPHASIS CONTROL SETTINGS	50
Table 87. PHY XS EQUALIZATION CONTROL	50
Table 88. PHY XS RECEIVE PATH TEST AND STATUS FLAGS	50
Table 89. PHY XS OUTPUT AND TEST FUNCTION CONTROL REGISTER	51
Table 90. PHY XS STATUS 4 LOS DETECTOR REGISTER	51
Table 91. PHY XS CONTROL REGISTER 4	51
Table 92. AUTO-CONFIGURE REGISTERS	51
Table 93. JTAG OPERATIONS	53
Table 94. CLOCK PINS	55

Table 95. XAUI (XENPAK/XPAK/X2) SIDE SERIAL DATA PINS	55
Table 96. PMA/PMD (CX4/LX4) SIDE SERIAL DATA PINS	55
Table 97. JTAG INTERFACE PINS	55
Table 98. MANAGEMENT DATA INTERFACE PINS	56
Table 99. MISCELLANEOUS PINS	56
Table 100. I2C 2-WIRE SERIAL DATA INTERFACE PINS	57
Table 101. VOLTAGE SUPPLY PINS	57
Table 102. ABSOLUTE MAXIMUM RATINGS	60
Table 103. RECOMMENDED OPERATING CONDITIONS	60
Table 104. POWER DISSIPATION AND THERMAL RESISTANCE	60
Table 105. PMA SERIAL PIN I/O ELECTRICAL SPECIFICATIONS, CX4 MODE (3)	61
Table 106. PMA SERIAL PIN I/O ELECTRICAL SPECIFICATIONS, LX4 MODE	61
Table 107. PHY XS SERIAL PIN I/O ELECTRICAL SPECIFICATIONS, XAUI MODE	61
Table 108. EXTERNAL 1.2V CMOS OPEN DRAIN I/O ELECTRICAL SPECIFICATIONS	61
Table 109. 1.5V CMOS INPUT/OUTPUT ELECTRICAL SPECIFICATIONS	62
Table 110. 2.5V TOLERANT OPEN DRAIN CMOS INPUT/OUTPUT ELECTRICAL SPECIFICATIONS	62
Table 111. OTHER DC ELECTRICAL SPECIFICATIONS	62
Table 112. REFERENCE CLOCK REQUIREMENTS	63
Table 113. TRANSMIT SERIAL DIFFERENTIAL OUTPUTS (SEE Figure 9, Figure 10 AND Figure 11)	63
Table 114. RECEIVE SERIAL DIFFERENTIAL INPUT TIMING REQUIREMENTS (SEE Figure 11)	63
Table 115. MDIO INTERFACE TIMING (FROM IEEE802.3AE) (SEE Figure 15 TO Figure 17)	64
Table 116. RESET AND MDIO TIMING (SEE Figure 17)	64
Table 117. RESET AND I2C SERIAL INTERFACE TIMING (SEE Figure 18 AND Figure 24)	64

FIGURE 2. DETAILED FUNCTIONAL BLOCK DIAGRAM (BIST OMITTED)
 (See also Figure 4 & Figure 5 for MDIO and LASI blocks and Figure 6 for BIST operation)

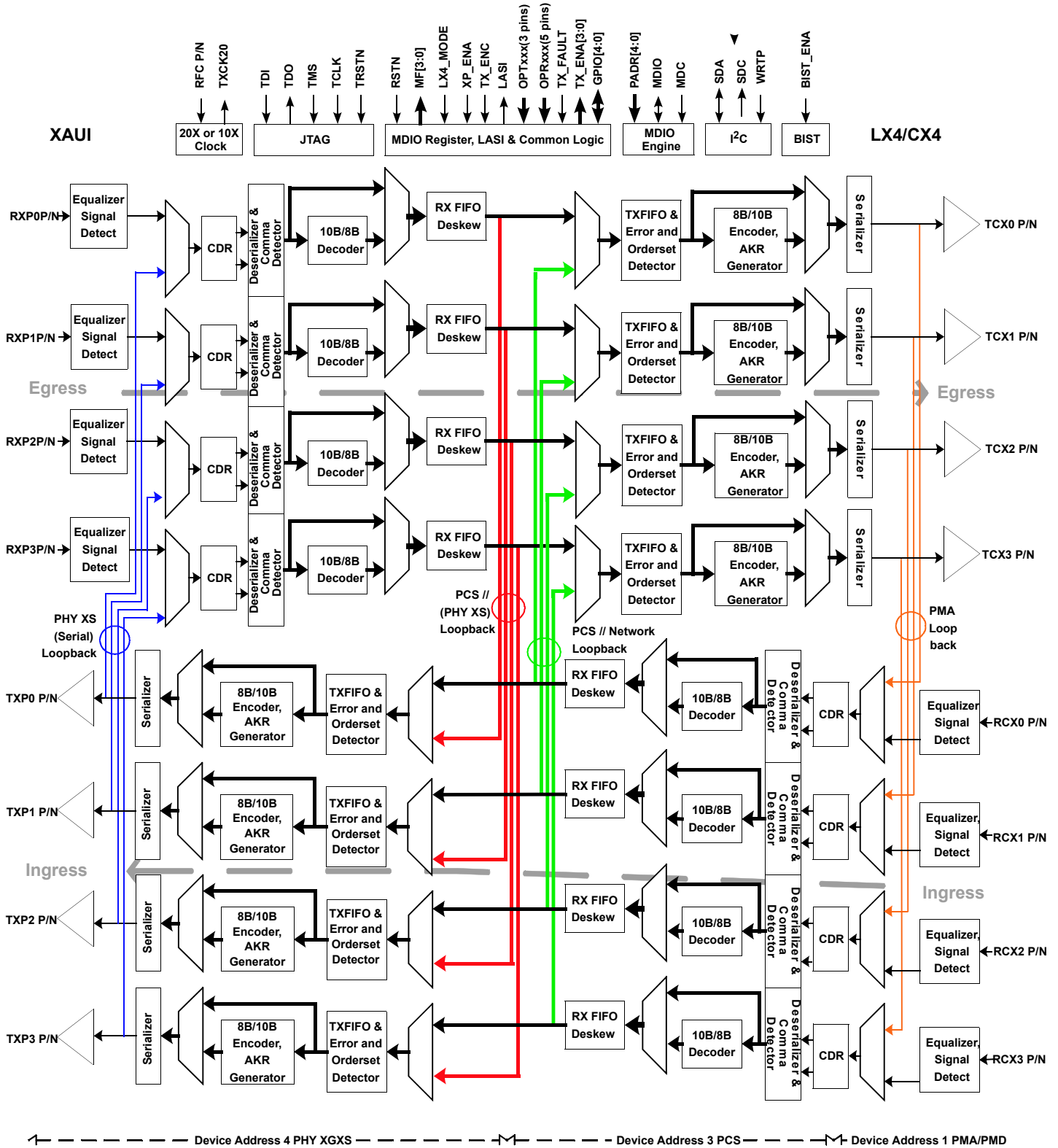

General Description

The nLiten BBT3821 is a fully integrated octal 2.488Gbps to 3.1875Gbps Clock and Data Recovery (CDR) circuit and Retimer ideal for high bandwidth serial electrical or optical communications systems. It extracts timing information and data from serial inputs at 2.488Gbps to 3.1875Gbps, covering 10 Gigabit Fiber Channel (10GFC) and IEEE 802.3 specified 10 Gigabit Ethernet eXtended Attachment Unit Interface (XAUI) rates.

Each BBT3821 accepts two sets of four high-speed differential serial signals, re-times them with a local Reference Clock, reduces jitter, and delivers eight clean high-speed signals. The BBT3821 provides a full-function XAUI-to-10GBASE-CX4 PMA/PMD (compatible with the IEEE 802.3ak specification), and also can be configured to provide the electrical portion of a XAUI-to-10GBASE-LX4 PMA/PMD, needing only laser drivers and photo detectors to be added. In both these applications, the XAUI side can be configured to implement the XENPAK MSA_R3.0 specification, including full NVR and DOM support. The XPAK and X2 specifications currently all reference the XENPAK specification, and are supported in exactly the same manner. The BBT3821 can also be used to enhance a single full-duplex 10 Gigabit XAUI link, extending the driving distance of the high-speed (2.488Gbps to 3.1875Gbps) differential traces to 40 inches of FR4 PCB (assuming a proper impedance-controlled layout).

Each lane can operate independently with a data transfer rate of within ± 100 ppm of either 20x or 10x the local Reference Clock. The reference clock should be 156.25MHz for 10 Gigabit Ethernet XAUI applications, and 159.375MHz for 10 Gigabit Fiber Channel. Other reference frequencies can be used for proprietary rates. For other applications, each of the 8 lanes can be operated independently, within the same data rate and clock restrictions.

The nLiten BBT3821 contains eight clock & data recovery units, 8B/10B decoders and encoders, and elastic buffers which provide the user with a simple interface for transferring data serially and recovering it on the receive side. When recovering an 8B/10B stream, a receive FIFO aligns all incoming serial data to the local reference clock domain, adding or removing IDLE sequences as required. This simplifies implementation of an upstream ASIC by removing the requirement to deal with multiple clock domains. The Retimer can also be configured to operate as eight non-encoded 10-bit Retimers. Allowing long strings of consecutive 1's or 0's (up to 512 bits), the nLiten BBT3821 has the capacity to accommodate proprietary encoded data links at any data rate between 2.488Gbps and 3.1875Gbps (and for half rate operation from 1.244Gbps to 1.59375Gbps).

The device configuration can be done through the use of the two line Management Data Input/Output (MDIO) Interface

specified in IEEE 802.3 Clause 45. The BBT3821 supports a 5-bit Port Address, and DEvice ADresses (DEVAD) 1, 3 & 4. The initial values of the registers default to values controlled, where appropriate, by external configuration pins, and set to optimize the initial configuration for XAUI, CX4, and XENPAK/XPAK/X2 use. Optionally, the BBT3821 configuration can be loaded at power-on or reset from the NVR EEPROM or DOM used for the XENPAK/XPAK/X2 registers.

A full suite of loopback configurations is provided, including the (802.3ae required) XAUI-transmit to XAUI-receive loopback, and also the (802.3ae optional) PHY XGXS loopback (effectively CX4/LX4-receive to CX4/LX4 transmit). Lane-by-lane diagnostic loopback is available through vendor-specific MDIO registers.

The low-power version BBT3821LP-JH is selected for operation as an LX4 device at lowered supply voltages.

Functions

The nLiten BBT3821 serves three main functions:

- Pre-emphasize the output and equalize the input in order to “re-open” the data eye, thus allowing CX4 operation, and also increasing the available driving distance of the high-speed traces in XAUI links.
- Clock compensation by insertion and deletion of IDLE characters when 8B/10B encoding and decoding is enabled.
- Automatic Byte and Lane Alignment, using both disparities of /K/ for Byte alignment and either ||A|| or IDLE to DATA transitions for lane alignment.

Receiver Operations

Loss of Signal Detection, Termination & Equalization

Each receiver lane detects and recovers the serial clock from the received data stream. An equalizer has been added to each receiver input buffer, which boosts high frequency edge response. The boost factor can be selected from 16 values (none to full) through the MDIO Registers, (see Table 43 for the PMA/PMD and Table 87 for the PHY XS).

A nominally 100 Ω on-chip transmission line terminating resistor is integrated with the input equalizer. This eliminates the requirement of external termination resistors. It greatly improves the effectiveness of the termination, providing the best signal integrity possible.

There are also signal detect functions on each input lane, whose “Loss Of Signal” (LOS) and “Signal Detect” (SIG_DET) outputs appear in the MDIO Vendor-Specific registers at address 1.C00A'h (Table 44) and 4.C00A'h (Table 90). The LOS indication reflects the standard XAUI specification, while the SIG_DET indication (CX4 inputs only) implements the CX4 function. These signals can also

be routed to the MF[3:0] pins (see Table 81 and Table 99). The PMA configuration determines which of these signals will be reflected in the IEEE PMD Receive signal detect register at 1.10 (see Table 12), and contribute to the RX_FAULT bit in the IEEE Status Register 2 at address 1.8 (see Table 10) and the LOCAL_FLT bit in the IEEE PMA/PMD Status 1 Register, at address 1.1, (see Table 6). The PHY XGXS LOS will be reflected in the IEEE Status Registers at addresses 4.8 and 4.1 (see Table 77 and Table 76). The threshold of the LOS detectors is controlled via the 'LOS_TH' bits in the MDIO registers at 1.C001'h, see Table 39, for the PMA/PMD, and for the PHY XS at 4.C001'h, see Table 81.

Clock and Data Recovery

When the 8B/10B coding is used, the line rate receive clock is extracted from the transition rich 10-bit coded serial data stream independently on each lane. When 8B/10B coding is not used, longer run length (up to 512 1's and 0's) can be supported. The data rate of the received serial bit stream must be within ± 100 ppm of the nominal bit rate (strictly within ± 200 ppm of the multiplied local reference clock) to guarantee proper reception. The receive clock locks to the input within 2 μ s after a valid input data stream is applied. The received data is de-serialized and byte aligned.

Byte Alignment (Code-Group Alignment)

Unless the CDET bits of the MDIO Registers at address 3.C000'h (for PCS, see Table 63) or 4.C000'h (for PHY XS, see Table 80) are turned off, the respective Byte Alignment Units are activated. Each Byte Alignment Unit searches the coded incoming serial stream for a sequence defined in IEEE 802.3-2002 Clause 36 as a "comma". A comma is the sequence "0011111" or "1100000" depending on disparity, and is uniquely located in a valid 8B/10B coded data stream, appearing as the start of some control symbols, including the /K/ IDLE (K28.5). Comma disparity action can be controlled via the same CDET bits of the registers [3:4].C000'h (see Table 63 and Table 80). Any proprietary encoding scheme used should either incorporate these codes, or arrange byte alignment differently.

Upon detection of a comma, the Byte Alignment Unit shifts the incoming data to align the received data properly in the 10-bit character field. Two possible algorithms may be used for byte alignment. The default is that specified in the IEEE802.3ae-2002 clause 48 specification, and is very robust. This algorithm relies on the 10b/8b decoder, and should not be used with proprietary encoding/decoding schemes. The alternative is to byte-align on any comma pattern. Although quick to align, and normally quite reliable, this method is susceptible to realignment on certain single bit errors or on successive K28.7 characters, but could be preferable for proprietary coding schemes, or during debug. The algorithm selection is controlled via MDIO register PCS_SYNC_EN bits, for the PCS at address 3.C000'h (Table 63), for the PHY XS at address 4.C000'h (Table 80),

unless overridden by the respective XAUI_EN bits in the [3,4].C001'h registers (Table 64 and Table 81). Up to a full code group may be deleted or modified while aligning the "comma" code group correctly to the edges of the RefClock. A comma received at any odd or even byte location, but at the proper byte boundary, will not cause any byte re-alignment.

8b/10b Decoding

The internal 10b decoding specified in the IEEE802.3-2002 specification, section 36.2.4 in Tables 36-1 & 36-2, and discussed in more detail in "8b/10b Coding and Decoding" page 12, is enabled by default in the PCS and PHY XS through the setting of the respective CODECENA bits to 1'b, and may be disabled through the MDIO registers [3,4].C000'h (Table 63 and Table 80) by setting the respective bit to 0'b. Note that the transmit encoding will also be disabled. Although Comma detection will still operate normally, the PCS_SYNC engine (see above) may not operate correctly on a proprietary coding scheme, unless byte sync is performed on K28.5 characters, and no code violations are to be expected in the proprietary data, and so should normally be disabled if the 8b/10b coding is turned off. The 'fallback' byte sync operations described above can still be used, if the encoding scheme meets the "comma" rules; otherwise they should be disabled also via the CDET bits, and the user should expect unsynchronized 10-bit data to be forwarded to the transmitter. No clock compensation is then possible, and a synchronous reference clock should be used throughout.

Receive FIFO

The Receive FIFO performs two functions:

1. Lane to Lane Alignment
2. Clock Compensation

Deskew (Lane to Lane) Alignment

Trunking, also known as deskewing, means the alignment of packet data across multiple lanes. 8 bytes of RXFIFO are dedicated for this lane to lane alignment in each direction.

During high-speed transmission, different active and passive elements in the links may impart varying delays in the four lanes. In trunking mode, multiple lanes share the same clock (the local reference clock), which is used to transfer data for output on the serial transmitter.

Deskewing is accomplished by monitoring the contents of the FIFOs to detect either an /A/ code-group on every lane (an ||A|| Ordered_Set), or the boundary between IDLE sequences and any non-IDLE data (see Table 1); the latter boundary defines the beginning of the packet. The choice of which alignment markers to use can be controlled by the A_ALIGN_DIS bits in MDIO [3,4].C000'h (see for PCS Table 63 and for PHY XS Table 80), unless overridden by the respective XAUI_EN bits in the [3,4].C001'h registers (Table 64 and Table 81) to align on ||A||. When this alignment

data is detected in all four lanes within the span of the Alignment FIFO, the deskewing (lane to lane) alignment operation is performed, and will be held until another $||A||$ or IDLE-to- non-IDLE transition is detected again on the lanes. During this alignment, up to four code groups may be deleted on any lane. For correct operation, the XAUI Lane 0 signals should be connected to the BBT3821 Lane 0 pins.

The deskew algorithm state machines (each implemented according to IEEE 802.3ae) are enabled by setting the DSKW_SM_EN bits (Address [3,4].C000'h, see Table 63 and/or Table 80) to 1 or overriding them with the respective XAUI_EN bits in the [3,4].C001'h registers (Table 64 and Table 81). Note that when one side's DSKW_SM_EN is set to 1, the same side CAL_EN bit (Address [3,4].C000'h, Table 63/Table 80) is ignored. When a DSKW_SM_EN bit is set to 0, lane deskew can still be enabled by setting CAL_EN, but the deskew action will be carried out without hysteresis.

The user has the option to disable trunking, or to enable trunking across each set of 4 lanes, in the PCS (device 3) and PHY XGXS (device 4), under control of the respective PSYNC bits in registers [3,4].C000h. In trunking mode, the lanes may have phase differences, but they are expected to be frequency synchronous. In non-trunking mode, each received serial stream need only be within ± 100 ppm of the nominal bit rate (2.488Gbps to 3.1875Gbps in full-speed mode or 1.244Gbps to 1.59375Gbps in half-speed mode). Setting the PSYNC bits high will enable the trunking mode, so that all transmitted data will be synchronized to the same clock. Note that trunking mode is only possible if 8B/10B Coding is activated, and all lanes have the same half-rate setting (See Table 71).

Clock Compensation

In addition to deskew, the Receive FIFOs also compensate for clock differences. Since the received serial streams can, under worst case conditions, be off by up to ± 200 ppm from the local clock domain, the received data must be adjusted to the local reference clock frequency.

Another 8 bytes of RXFIFO are dedicated for clock compensation. The FIFOs achieve clock tolerance by identifying any of the IDLE patterns (/K/, /A/ or /R/ as defined by the IEEE 802.3ae standard) in the received data and then adding or dropping IDLEs as needed. The Receive FIFO does not store the actual IDLE sequences received but generates the number of IDLEs needed to compensate for clock tolerance differences. The IDLE patterns retransmitted will be determined according to the IEEE 802.3ae algorithm if the appropriate AKR_SM_EN bit is set in Registers [3,4].C001'h (see Table 64 and Table 81).

Transmitter Operations

8b/10b Encoding

The internal 10b encoding specified in the IEEE802.3-2002 specification, section 36.2.4 in Tables 36-1 & 36-2, and discussed in more detail in "8b/10b Coding and Decoding" page 12, is enabled by default in the PCS and PHY XS through the setting of the respective CODECENA bits to 1'b, and may be disabled through the MDIO registers [3,4].C000'h (see Table 63 and Table 80) by setting the respective bit to 0'b. Note that the receive decoding will also be disabled. The (decoded, synchronized and aligned) data is transferred via the transmit FIFOs, (normally) encoded, serialized and re-transmitted on the Serial Output pins, whose effective output impedance is nominally 100 Ω differential.

Pre-Emphasis

In order to compensate for the loss of the high frequency signal component through PCB traces or the CX4 Cable Assembly, sixteen levels of programmable pre-emphasis have been provided on the CX4/LX4 PMA serial transmit lanes, and eight levels on the XAUI PHY XS serial transmit lanes. The output signal is boosted immediately after any transition (see Figure 3). This maximizes the data eye opening at the receiver inputs and enhances the bit error rate performance of the system. The MDIO Registers at Addresses [1,4].C005'h (see Table 41 and Table 85) control the level of pre-emphasis for the PMA/PMD (sixteen levels) and PHY XGXS (eight levels) respectively, settable from none to the maximum. The initial default values of the PMA/PMD register depend on the LX4_MODE configuration pin, and are set to the optimum values for CX4 or XAUI (assumed best for LX4 drivers). Both these registers may be auto-loaded (see Auto-Configuring Control Registers page 16) from an NVR EEPROM on start-up or RESET.

FIGURE 3. PRE-EMPHASIS OUTPUT ILLUSTRATION

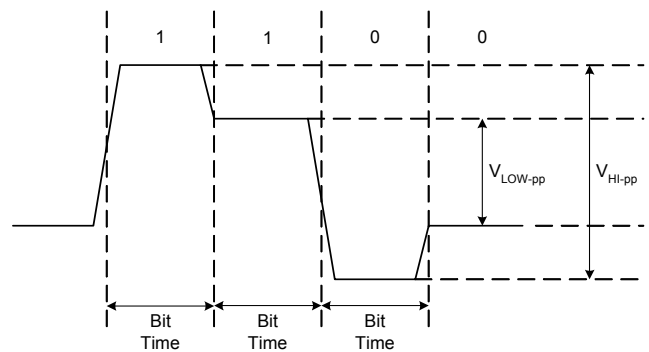

8b/10b Coding and Decoding

8 Bit Mode

If 8B/10B encoding/decoding is turned on, the nLiteN BBT3821 expects to receive a properly encoded serial bit stream. The serial bit stream must be ordered “abcdeifghj” with “a” being the first bit received and “j” the last. If the received data contains an error, the Retimer will re-transmit it as an ERROR or /E/ character. The character transmitted may be controlled via the ERROR code Registers [3,4].C002’h, Table 66 and Table 82. The internal decoding into, and encoding from, the FIFOs is listed in Table 1 below. If the TRANS_EN bit or XAUI_EN bit (MDIO Registers at addresses [3,4].C001’h, see Table 64 and Table 81) are set, all incoming XAUI or CX4/LX4 IDLE patterns will be converted to the (internal) XGMII IDLE pattern set by the respective PCS or PHY XS control registers at addresses [3,4].C003’h, with a default value 107’h, the standard XGMII IDLE code (see Table 67 and Table 83) in the internal FIFOs. The first full column of IDLES after any column containing a non-IDLE will be stored in the respective elasticity FIFO, and all subsequent full IDLE columns will repeat this pattern, until

another column containing a non-idle is received. In addition either of the AKR_SM_EN or XAUI_EN bits in the respective MDIO registers at Addresses [3,4].C001’h is set (see Table 64 and Table 81, these IDLEs will be sequenced on transmission into a pseudo-random pattern of ||A||, ||K||, and ||R|| codes according to the IEEE 802.3ae specified algorithm. If neither of the AKR_SM_EN and XAUI_EN bits are set, the internal IDLEs will all be transmitted as /K/ codes. Elasticity will be achieved by adding or deleting columns of internal IDLEs.

If neither the TRANS_EN bit nor the XAUI_EN bit is set (for either the PCS or the PHY XS), the incoming XAUI IDLE codes will all be decoded to the appropriate XGMII control code values in the respective internal FIFO. If the AKR_EN or XAUI_EN bits are set, they will be sequenced into a pseudo-random pattern of ||A||, ||K||, and ||R|| codes and retransmitted, if not, the Inter Packet Gap (IPG) will be retransmitted as the same XAUI codes as in the first full IDLE column.

For most applications, the XAUI_EN bit high configuration is the most desirable, and is the default.

Table 1. VALID 10b/8b DECODER & ENCODER PATTERNS

RECEIVING SERDES		INTERNAL DATA			TRANSMITTING SERDES			NOTES
SERIAL CODE, CHARACTER	TRANS_EN BIT ⁽⁴⁾	E-BIT	K-BIT	INTERNAL FIFO DATA	AKR_SM_EN ⁽⁴⁾	SERIAL CHARACTER	SERIAL CODE	DESCRIPTION
Valid Data	X	0	0	0-FF’h	X	See 802.3 Table	Valid Data	Same Data Value as Received
/K/ (Sync) K28.5	1	0	1	07’h ⁽²⁾	1	/A/ /K/ /R/		IEEE802.3ae algorithm
	0	0	1	BC ⁽¹⁾	0	/K/	K28.5	Comma (Sync)
/A/ (Align) K28.3	1	0	1	07’h ⁽²⁾	1	/A/ /K/ /R/		IEEE802.3ae algorithm
	0	0	1	7C ⁽¹⁾	0	/A/	K28.3	Align
/R/ (Skip) K28.0	1	0	1	07’h ⁽²⁾	1	/A/ /K/ /R/		IEEE802.3ae algorithm
	0	0	1	1C ⁽¹⁾	0	/R/	K28.0	Alternate Idle (Skip)
/S/ K27.7	X	0	1	FB	1	/S/	K27.7	Start
/T/ K29.7	X	0	1	FD	0	/T/	K29.7	Terminate
K28.1	X	0	1	3C	X		K28.1	Extra comma
/F/ K28.2	X	0	1	5C	X	/F/	K28.2	Signal Ordered_Set
/Q/ K28.4	X	0	1	9C	X	/Q/	K28.4	Sequence Ordered_Set
K28.6	X	0	1	DC	X		K28.6	
K28.7	X	0	1	FC	X		K28.7	Repeat has False Comma
K23.7	X	0	1	F7	X		K23.7	
/E/ K30.7	X	1	1	FE	X	/E/	K30.7	Error Code
Any other	X	1	= ERROR reg. ⁽³⁾		X	Invalid code		Error Code

Note (1): First incoming IDLE only, subsequent IDLEs in that block repeat first received code.

Note (2): Default value, actually set by 'Internal Idle' register, [3:4].C003’h, see Table 67 and Table 83.

Note (3): Value set by 'ERROR Code' register, [3:4].C002’h, see Table 66 and Table 66. The XAUI_EN bit forces it to 1FE’h.

Note (4): If the XAUI_EN bit is set, the BBT3821 acts as though both the TRANS_EN and AKR_EN bits are set.

10 Bit Mode

If a PCS or PHY XS 8B/10B codec is inactive (the respective XAUI_EN AND CODECENA bits are disabled, see Table 63/Table 64 & Table 80/Table 81), no 8b/10b coding or decoding is performed. The incoming bits will be arbitrarily split into 10 bit bundles in the internal FIFO, optionally based on any commas received, but otherwise not checked, and must be retransmitted in the same clock domain, since no elasticity is possible. Therefore the local reference clock must be frequency synchronous with the data source. Only the jitter domain will be reset. System designers must ensure that the data stream is adequately DC-balanced and contains sufficient transition density for proper operation, including synchronization.

Error Indications

An equivalent schematic of the various IEEE-defined and Vendor Specific Fault and Status registers in the BBT3821 is shown in Figure 4. Those register signals that also contribute to the LASI system are indicated (see Figure 5).

Loss of Signal

If the reference clock is missing or at an out-of-range frequency, the PLL in the CMU will fail to lock. This is the only possible internal cause of a PMA 'TX Local Fault' indication in bit 1.8.11 (Table 10), and will cause 'RX Local Fault' in bit 1.8.10 and other consequent fault indications (see Table 6, Table 27 and Table 28).

Loss of the input signal may be caused by poor connections, insufficient voltage swings, or excessive channel loss. If any of these conditions occurs, the Loss Of Signal (LOS) and (CX4) SIG_DET detector outputs on the lane will indicate the fault, and may be monitored via the MDIO system (see Table 6, Table 10, Table 27, Table 28, Table 76 and Table 77). See also the section on "Loss of Signal Detection, Termination & Equalization" on page 9 above. In addition, the MDIO MF_SEL and MF_CTRL register bits (address 4.C001'h, see Table 81) may be set to provide the LOS/SIG_DET indication on the MF[3:0] pins.

Byte or Lane Synchronization Failure

The MDIO system can indicate a failure to achieve Byte Synchronization on any lane, in the PCS register bits 3.24.3:0 (Table 61) or in the PHY XS register bits 4.24.3:0 (Table 78), which shows the lane-by-lane Byte Sync status. A failure here, if not caused by any of the above 'Loss of Signal' conditions, would normally reflect a very high bit error rate, or incorrectly coded data.

Failure of Lane Synchronization is indicated for the PCS by register bit 3.24.12 (Table 61) or for the PHY XS by register bit 4.24.12 (Table 78), and can be caused by failure to detect /A/ characters on every lane of a channel, by excessive skew between /A/s on the lanes of a channel, or by inconsistent skews.

Channel Fault Indications

Any of the above faults (LOS/SIG_DET, Byte Sync, or Lane Align), will (by default) cause a local fault in the relevant receiver. If the PCS_SYNC_EN bit at address [3,4]C000'h (or the XAUI_EN bit at [3:4].C001'h) (see Table 63 to Table 65 and/or Table 80 to Table 81) is set, the internal FIFOs will propagate the local fault indication specified in the IEEE802.3ae-2002 specification (Sections 46.3.4 and 48.2.4.2) as the Sequence Ordered_Set ||LF|| (see Table 48-4), /K28.4/D0.0/D0.0/D1.0/, which will be transmitted as the appropriate XAUI or LX4/CX4 TX output. The BBT3821 lanes 0-3 must be connected to XAUI and LX4/CX4 lanes 0-3 in strict order. Any Sequence Ordered_Set (including ||LF|| and ||RF||) received on an input channel will be retransmitted unchanged on the appropriate output channel.

Coding Violation, Disparity & FIFO Errors

The 8b/10b decoder will detect any code violation, and replace the invalid character by the error character /E/. In the case of a disparity error, the error may be propagated and only flagged at the end of a packet (according to the IEEE 802.3 rules). The BBT3821 will handle this according to those rules. In addition, the MDIO system includes a flag, in registers [3,4].C007'h on bits 11:8 (see Table 69 and Table 88). Similarly, an error in the PCS or PHY XS Elastic (clock compensation) FIFOs will be flagged in bits 7:4 of the same registers. The FIFO errors may also be flagged on the MF[3:0] pins via the MDIO MF_SEL and MF_CTRL register bits (address 4.C001'h, see Table 81).

If a PCS or PHY XS 8B/10B codec is inactive, disparity error and coding violation errors do not apply, and the FIFOs have no active error source.

Loopback Modes

In addition to the IEEE 802.3ae-required loopback modes, the BBT3821 provides a number of additional modes. Each mode is described in detail below, by reference to the Detailed Functional Block Diagram in Figure 2, together with the register bits controlling it.

PMA Loopback (1.0.0 & 1.C004.[11:8])

The PMA loopback is implemented from the output of the TCX[3:0] serializers to the input multiplexers in front of the RCX[3:0] CDRs. All four lanes are controlled by bit 1.0.0, while the individual lanes can be controlled (one at a time) by the 1.C004'h.[11:8] bits. Assuming that this is the only loopback enabled, and that the BIST and test pattern generation features are not enabled, the signal flow is from the RXP[3:0][P/N] pins through almost all the 'egress' channel to the input of the (still active) TCX[3:0] output drivers, then (bypassing the RCX[3:0][P/N] inputs, the equalizers and LOS detectors) back from the CDRs through almost all the 'ingress' channel to the TXP[3:0][P/N] pins.

FIGURE 4. IEEE AND VENDOR SPECIFIC FAULT AND STATUS REGISTERS (EQUIVALENT SCHEMATIC)

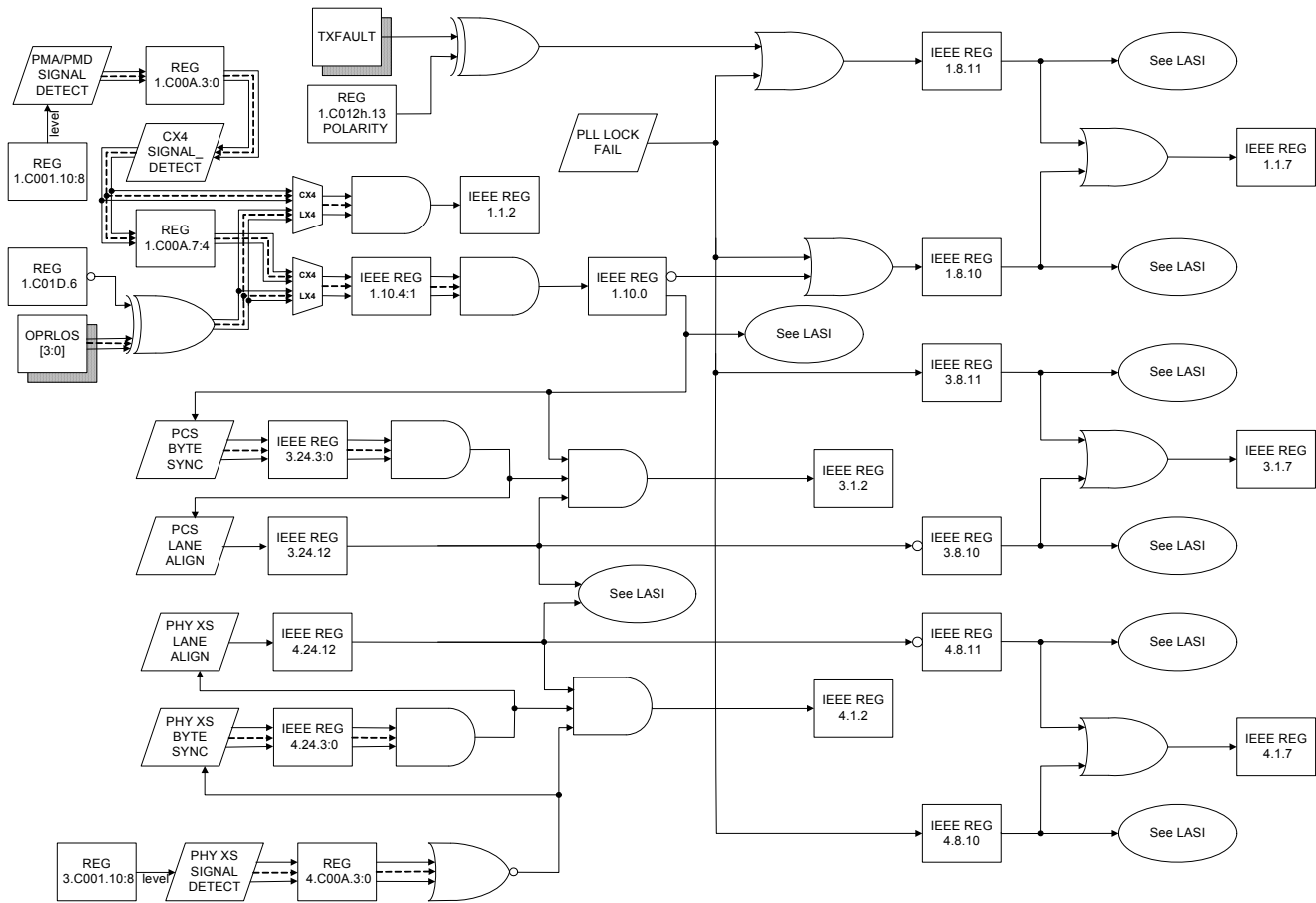

PHY XS (Serial) Loopback (4.0.14 & 4.C004.[11:8])

The PHY XS loopback is implemented from the output of the TXP[3:0] serializers to the input multiplexers in front of the RXP[3:0] CDRs. All four lanes are controlled by bit 4.0.14, while the individual lanes can be controlled (one at a time) by the 4.C004'h.[11:8] bits. Assuming that this is the only loopback enabled, and that the BIST and test pattern generation features are not enabled, the signal flow is from the RCX[3:0][P/N] pins through almost all the 'ingress' channel to the input of the (still active) TXP[3:0] output drivers, then (bypassing the RXP[3:0][P/N] inputs, the equalizers and LOS detectors) back from the CDRs through almost all the 'egress' channel to the TCX[3:0][P/N] pins.

PCS Parallel Network Loopback (3.C004.[3:0])

This loopback is implemented (at the internal XGMII-like level) from the output of the RXFIFOs in the 'ingress' channel to the input of the TXFIFOs in the 'egress' channel. The individual lanes can be controlled (one at a time) by the 3.C004'h.[3:0] bits. Assuming that this is the only loopback enabled, and that the BIST and test pattern generation features are not enabled, the signal flow is from the RCX[3:0][P/N] pins through the PMA/PMD and PCS and again PMA/PMD to the TCX[3:0][P/N] pins. This could also be seen as a 'short' loopback at the XGMII input of the PHY XS.

PCS (Parallel) Loopback (4.C004.[3:0] & Optionally 3.0.14)

This loopback is implemented (at the internal XGMII-like level) from the output of the RXFIFOs in the 'egress' channel to the input of the TXFIFOs in the 'ingress' channel. The individual lanes can be controlled (one at a time) by the 4.C004'h.[3:0] bits. If the enable bit in 3.C001.7 (Table 64) is set, all four lanes can be controlled by bit 3.0.14. Since the latter is specifically excluded by subclause 45.2.3.1.2 of the IEEE 802.3ae-2002 specification for a 10GBASE-X PCS, the default is to NOT enable this loopback bit, and if it is enabled, the BBT3821 does not conform to the IEEE specification. A maintenance request has been submitted to the IEEE to enable this loopback bit as optional, and to allow a 'PCS Loopback Capability' bit in register bit 3.24.10 (see http://www.ieee802.org/3/maint/requests/maint_1113.pdf), but this has so far been rejected, and may never be approved. Assuming that this is the only loopback enabled, and that the BIST and test pattern generation features are not enabled, the signal flow is from the RXP[3:0][P/N] pins through the full PHY XS via the internal XGMII to the TXP[3:0][P/N] pins. This could also be seen as a 'short' loopback at the XGMII input of the PCS.

Serial Test Loopbacks (1.C004.12 & 4.C004.12)

In addition to the above loopbacks, the BBT3821 also offers two serial loopbacks directly between the serial inputs and outputs. These loopbacks use the recovered clock as the timing for the outputs (instead of the multiplied reference clock), so do not reset the jitter or clock domains, and in addition do NOT provide any pre-emphasis on the outputs. Furthermore, on the PMA/PMD side (1.C004.12) the lanes are internally swapped (so the Lane 3 output is from the Lane 0 input, etc.). Because of their limited utility, they are not illustrated in Figure 2 or Figure 6. They are mainly useful for debugging an otherwise intractable system problem. The reference clock still needs to be within locking range of the input frequency. The remainder of the signal path will remain active (as normal), so that if for example 1.C004.12 is set, data coming in on RCX[3:0], in addition to emerging on TCX[0:3] without retiming, etc., will also emerge from TXP[3:0] retimed, as usual.

Serial Management Interface

The nLiten BBT3821 implements the MMD Management Interface defined in IEEE 802.3-2002 Clauses 22 & enhanced in IEEE 802.3ae-2002 Clause 45. This two-pin interface allows serial read/write of the internal control registers and consists of the MDC clock and MDIO data terminals. The PADR[4..0] pins are used to select the 'Port address' to which a given nLiten BBT3821 device responds. The BBT3821 will ignore Clause 22 format frames (on a frame-by-frame basis), based on the second ST (start) bit value. The two formats are shown in Table 3, together with the references to the respective IEEE 802.3 specifications.

MDIO Register Addressing

The PADR[4..0] hardware address pins control the PRTAD (Port Address) value, each port normally consisting of a series of MDIO Managed Devices (MMDs). Each Port may include up to 31 different devices, of which the current specification defines 8 types, and allows vendor specification of two others. The BBT3821 device corresponds to the PMA/PMD, PCS and PHY XGXS defined types, so responds to DEVAD values of 1, 3 and 4 respectively. The Clause 45-accessible registers are listed for each Device Address in the tables referenced in Table 2. Many of these register addresses are IEEE-defined; the 'Vendor Defined' registers are arranged to be as DEVAD independent as possible.

Table 2. DEVAD DEVICE ADDRESS TABLE

DEVAD VALUE	IEEE DEFINITION	REGISTER LIST TABLE
DEVAD = 1 (00001'b)	PMA/PMD Device	Table 4, page 19
DEVAD = 3 (00011'b)	PCS Device	Table 56, page 38
DEVAD = 4 (00100'b)	PHY XS (XGXS) Device	Table 74, page 45

Each individual device may have up to 2¹⁶ (65,536) registers. The BBT3821 implements all the defined registers for 10GBASE PMA/PMD, 10GBASE-X PCS and PHY XS devices, and a few Vendor Specific registers for each DEVAD respectively. The latter have been placed in the blocks beginning at D.C000'h so as to avoid the areas currently defined as for use by the XENPAK module and similar MSA devices, to facilitate use of the BBT3821 in such modules and systems.

Table 3. MDIO MANAGEMENT FRAME FORMATS

CLAUSE 22 FORMAT (FROM TABLE 22-10 IN IEEE STD 802.3-2002 EDITION, FOR REFERENCE)								
OPERN	PRE	ST	OP	PHYAD	REGAD	TA	DATA	IDLE
Read	1....1	01	10	PPPPP	RRRRR	Z0	DDDDDDDDDDDDDDDDDD	Z
Write	1....1	01	01	PPPPP	RRRRR	10	DDDDDDDDDDDDDDDDDD	Z
CLAUSE 45 FORMAT (FROM TABLE 45-64 IN IEEE 802.3.ae-2002)								
OPERN	PRE ⁽¹⁾	ST	OP	PRTAD	DEVAD	TA	ADDRESS/DATA	IDLE
Addr	1....1	00	00	PPPPP	DDDDD	10	AAAAAAAAAAAAAAAAAAAA	Z
Write	1....1	00	01	PPPPP	DDDDD	10	DDDDDDDDDDDDDDDDDD	Z ⁽²⁾
Read	1....1	00	11	PPPPP	DDDDD	Z0	DDDDDDDDDDDDDDDDDD	Z
Read Inc	1....1	00	10	PPPPP	DDDDD	Z0	DDDDDDDDDDDDDDDDDD	Z

Note (1): The 'Preamble' consists of at least 32 bits. After a software reset, a few extra preamble bits may be needed, depending on the MDC clock rate. See timing diagrams in Figure 15 and Figure 17.
 Note (2): The actual register will not be updated until up to three additional MDC cycles have been received. See Figure 15.

I²C Space Interface

In addition to the standard MDIO registers discussed above, the BBT3821 implements the register addresses specified in the XENPAK MSA specification for the NVR, DOM and LASI blocks. The built-in I²C controller can be configured to load these registers with the MSA-specified data on start-up or reset or on demand from an I²C EEPROM (frequently included as part of a DOM circuit) and/or one or four DOM circuits (see below). Optionally, a portion of the NVR space may be used to autoload the various BBT3821 control registers at start-up or reset. These operations are discussed in more detail below.

NVR Registers & EEPROM

If the XP_ENA pin is asserted enabled (high), at the end of hardware RESET or power-up the BBT3821 will attempt to load the NVR area by initiating a NVR-block read through the 1.32768 (1.8000'h) control register (Table 15). See Figure 18. The same will occur if the appropriate command value is written into this register. The I²C interface will attempt to read the A0.00:FF'h I²C space into the 1.8007:8106'h MDIO register space. The Command Status bits in the 1.32768 (1.8000'h) Control register will reflect the status of this operation. Failure may occur if the expected ACK is not received from any address after the number of attempts set in control register 1.32273 (1.8005'h), default 63 (Table 20), or if a collision is detected on the I²C bus. The timing sequence of this Block Read operation is shown in Figure 20. The host can check the checksums against the values at 1.807D, and optionally 1.80AD and 1.8106, and take appropriate action. As soon as the XENPAK MDIO space is loaded, the STA MDIO device may interrogate it. Note that the BBT3821 merely stores the values read from the EEPROM or other device at A0.00-FF'h, and, with a few exceptions, does not interpret them in any way. The exceptions are listed explicitly in Table 22, together with the other uninterpreted groups, and are:

- The Package OUI at 1.32818:32821 (1.8032:5'h), which will be mirrored in the IEEE-defined 1.14:15 (1.E:F'h) space, as required by section 10.8.2 of the XENPAK spec; the allowable values here are specified by the XENPAK, XPAK and X2 specifications;
- The DOM Capability byte at 1.32890 (1.807A), see the DOM Registers section, page 16;
- The Auto-configure size and pointer bytes at 1.33028:9(1.8104:5); (see Auto-Configuring Control Registers, page 16).
- If the Auto-configure operation is enabled, the block of bytes so specified will be written into the BBT3821 control registers, (see Auto-Configuring Control Registers on page 16 and Table 92).

Other registers may be interpreted in future versions of the BBT3821.

Auto-Configuring Control Registers

If the XP_ENA pin is asserted, and the I²C controller can successfully read the I²C NVR space into the MDIO NVR space, the BBT3821 will examine the Auto-configure Pointer value at 1.33029 (1.8105'h). If this is neither 00'h or FF'h, the BBT3821 will use that value (S below) as an offset pointer into the A0.00:FF'h I²C space already copied into the MDIO NVR space, and the number of bytes given in the Auto-configure Size register 1.33028 (1.8104) value (N below) to load N bytes from the NVR data starting from location S into the various BBT3821 configuration control registers. The loading sequence and the correspondence between the NVR block and the control registers is listed in Table 92. The auto-configure engine will behave benignly if the S and N values are misconfigured, so that if $S + N \geq 252$ (for example), the auto-configure block will stop at an S + N value of 252, and not use S, N, or the Checksum value to load a configuration control register. (Hence the exclusion of FF'h as a value for S is no limitation). Similarly, values of $N > 40$ will be ignored.

Note that in a XENPAK/XPAK/X2 module, the value of S should not be between 00'h and 76'h, since this would start the loading from within the MSA-defined region. (Hence the exclusion of 00'h as a value for S is normally no limitation). If the value of S lies between 77'h and A6'h, that portion of the auto-configure data within that band can be overwritten as part of the Customer Writable area defined by the MSA specifications; if this is undesirable, that range of values should also be excluded. On the other hand, this could be used to allow some customization for specific end-user configuration values. If the block overlaps the boundary between the 'Customer Writable' and 'Vendor Specific' areas, the first part would be customer-writable, and the second part not. The order of the configuration registers has been arranged to place those most likely to be useful in such a customer-configuration environment at the beginning of the block. The 'Customer Area Checksum' would be part of the auto-configure block, and some other byte in the 'Customer Writable Area' would need to be adjusted to make the Checksum and the desired configuration value coincide.

The Command Status bits in the NVR Command register (Table 15) at 1.32768.3:2 (1.8000'h.3:2) will reflect the success of both the NVR and (if called for) the auto-configure loading operations.

DOM Registers

If the NVR load operation succeeds, the (newly read-in) XENPAK register at 1.32890 (1.807A'h) is examined, and if the DOM Capability bit is set (bit 6, see Table 23), the I²C interface will attempt to read the DOM values from the I²C device address space specified in the same register (bits 2:0), normally 001'b pointing to A2'h. See Note (2) to Table 23 for details. A full block of data will be read from this space (normally A2.00:FF'h) into the 1.40960:41215 (1.A000: A0FF'h) MDIO register DOM space. See Figure 18 and Figure 20 for details. The DOM control register is implemented in the BBT3821 at

1.41216 (1.A100'h), so that one-time or (by default) periodic updates of the DOM information can be loaded into the MDIO DOM space by writing the appropriate values into it, as shown in Table 38, page 33. The actual automatic update rates selectable in this XENPAK-defined register are controlled by the DOM Control register in the BBT3821 vendor-specific register space at 1.49176 (1.C018'h), which also controls other actions of the DOM interface (see Table 51). In particular, since many available DOM circuits can handle only one lane, bit 2 enables or disables indirect access to separate DOM circuits on the four lanes. If the bit is 0'b, the DOM circuit is directly addressed at Ax.00:FF'h, and is assumed to provide the full four lane data, including the determination of which data is to be treated as the 'furthest out of range' or the 'representative value', as specified in Note 1 to Table 27 in section 11.2.6 of the XENPAK R3.0 specification, to be returned in the XENPAK-defined 1.A060:A06D'h space for a WDM module. If bit 2 of 1.C018'h is set to 1'b, the DOM data is polled from four devices attached to the I²C serial bus, getting 10 bytes from each of them. The 40 bytes of data are stored in the four lane register blocks starting from 1.A0C0'h, 1.A0D0'h, 1.A0E0'h and 1.A0F0'h respectively. The device addresses of these four DOM devices on the 2-wire bus are configured by registers 1.C01B'h and 1.C01C'h (Table 54); the starting memory addresses by registers 1.C019'h and 1.C01A'h (Table 53). Since the BBT3821 has no mechanism to determine out-of-range data, it chooses one of these four 10-byte long groups of data to copy into 1.A060'h:A069'h according to bits 1:0 of 1.C018'h (the 'representative' lane per the above-mentioned XENPAK Note). In addition, the Alarm and Status flags (Table 36 and Table 37) will be loaded from this lane into 1.A070:A075'h.

The BBT3821 assumes that the DOM circuit(s) will have these A/D values and flags at the same relative offsets as those specified in the XENPAK R3.0 and the SFF-8472 specifications.

General Purpose (GPIO) Pins

The BBT3821 includes some flexibly configurable General Purpose Input-Output (GPIO) pins, which may be configured to be inputs or outputs. As inputs, their level may be read directly via the MDIO system, but also they may be configured (again via MDIO registers, see Table 47 through Table 50) to optionally trigger the LASI on either a high or low level. The GPIO pins may also individually be used as outputs, and set high or low, under MDIO control. The GPIO control registers are among those that can be auto-configured on start-up.

LASI Registers & I/O

The BBT3821 implements the Link Alarm Status Interrupt (LASI) interface defined in section 10.13 of the XENPAK specification. The source and nature of these is described above under "Error Indications" on page 13 and in Figure 4. In addition to these specification-defined inputs, the BBT3821 incorporates a number of additional inputs, related

to the possible byte alignment and 8b/10b code violations, which may be used to trigger a LASI. The available inputs depend on the LX4/CX4 select LX4_MODE pin (Table 99), and are detailed in Table 27 and Table 28, and include:

1. Various status bits within the BBT3821, derived from its operations; in particular, the LOS indications, Byte Sync and EFIFO errors, the Fault bits [1,3,4].8.10:11, etc.
2. The Optical Interface Status pins (in LX4 mode), see Table 99.
3. The Alarm flags in 1.A070:1 (Table 36). These bits are gated with the enable bits in 1.9006:7 (Table 30 and Table 31) and the LX4/CX4 LX4_MODE pin (Table 99) to drive bits 1.9004.1 & 1.9003.1 (Table 28 & Table 27).
4. The GPIO pins (Table 100). If configured as inputs, they may be used to optionally trigger the LASI on either a high or low level. See above.

These status inputs can all be read via the LASI Status registers (1.9003 to 1.9005, see Table 27 to Table 29). Any of these inputs, if enabled via the LASI Control Registers, 1.9000 to 1.9002 (Table 24 to Table 26), can drive the LASI pin.

Figure 5 shows an equivalent schematic for the LASI system (an expansion of Figure 21 in the XENPAK specification).

Reading Additional EEPROM Space Via the I²C Interface

The I²C interface will allow single-byte reads from any possible I²C address. The device address and memory address are written into the 1.32769 (1.8001'h) and 1.32770 (1.8002'h) registers respectively (see Table 16 and Table 17), and on issuing a 'Read one byte' command (write 0002'h to 1.32768 = 1.8000'h) the data will be read from the I²C space in the MDIO register at 1.32771 (1.8003'h, see Table 18). For timing sequence, see Figure 22. Note that a 16-bit addressable EEPROM (or equivalent) device on the I²C bus may be read by setting the Long Memory bit 1.32773.8 (1.8005.8'h) to a '1', and writing a full 16-bit memory address value into 1.32770 (1.8002'h). This in principle allows access to almost a full 8MB of I²C space, excluding only the NVR and (optional) DOM device address portions. This 16-bit operation MUST NOT be used on an 8-bit device, since the register address setting operation will attempt to write the low byte of the address into the register at the high byte address. Such a 16-bit memory address device should be located at a device address not used by the NVR or DOM system.

These one-byte operations could be used to read other types of data from (multiple) DOM devices (such as limit lookup tables), or for expanded informational areas. It also facilitates the use of I²C-based DCP (Digital Control Potentiometer) devices for Laser Current control, and other similar setup and monitoring uses.

FIGURE 5. LASI EQUIVALENT SCHEMATIC
(See Also Figure 4)

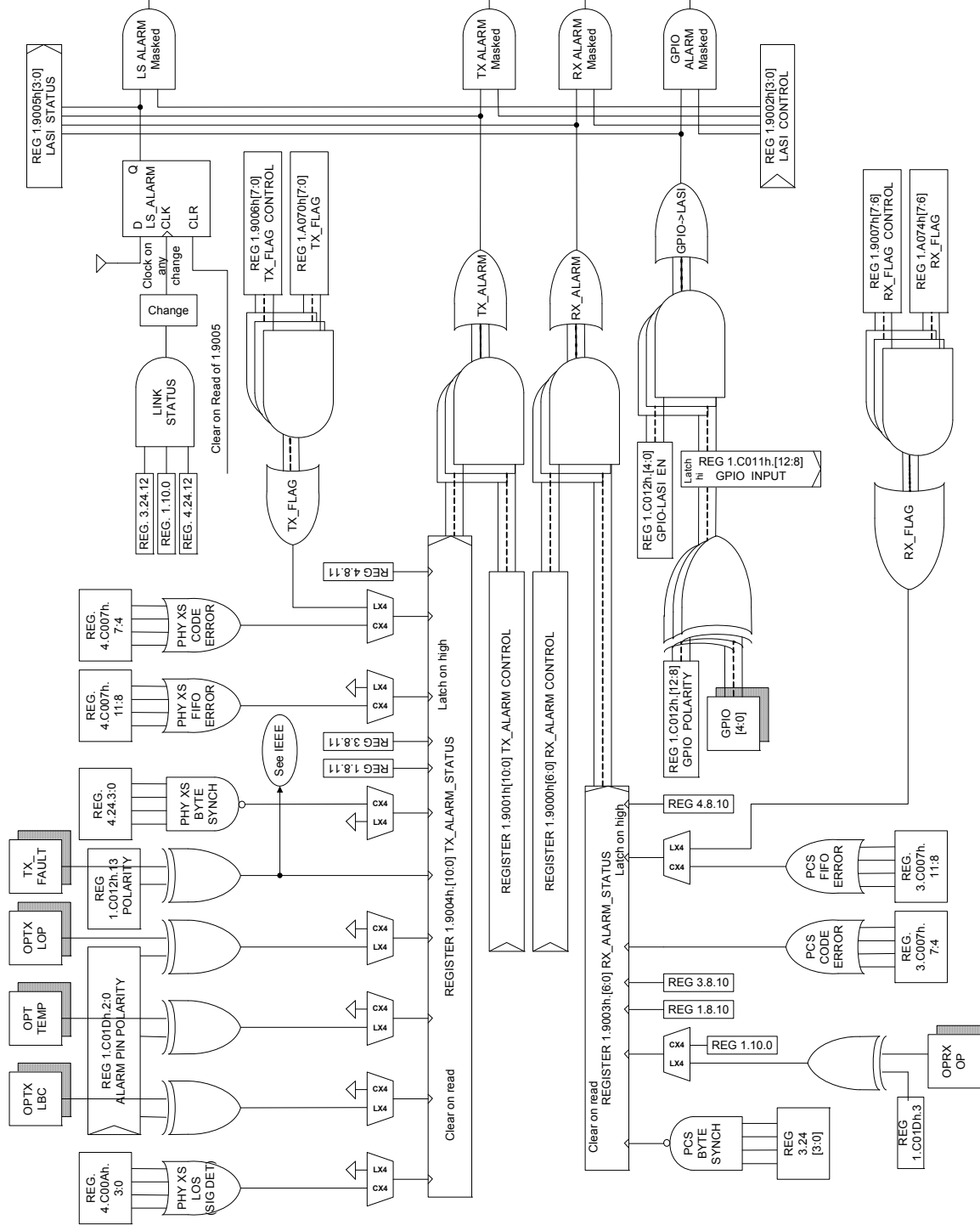

Writing EEPROM Space through the I²C Interface

The BBT3821 permits two methods for writing the requisite values into EEPROM or other I²C devices from the MDIO space into the I²C register space. Many DOM circuits protect their important internal data through some form of password protection, and in general the BBT3821 will allow this to be done without a problem.

BLOCK WRITES TO EEPROM SPACE

The first method is applicable only to the NVR space (I²C address space A0.00:FF'h). If the WRTP (Write Protect) pin is inactive (low), and the NVR Write Size bit (1.32773.7 = 1.8005.7'h) is set to a '1', then issuing a 'Write All NVR' command (write 0023'h to 1.32768 = 1.8000'h) will write the current contents of MDIO registers 1.8007:8106'h into the NVR space. The 'NVR Write Page Size' bits in 1.32773.1:0 (1.8005.1:0'h) control the block size used for the write operation. See Figure 21 for the sequence timing. Normally this operation is only useful for initialization of a module EEPROM space, but it could be used for field upgrades or the like. If the WRTP (Write Protect) pin is high (active, normal condition), OR the Write Size bit (1.32773.7 = 1.8005.7'h) is cleared to a '0', then issuing a 'Write All NVR' command (write 0023'h to 1.32768 = 1.8000'h) will write only the current contents of the MDIO register block within 1.807F:80AE'h to the XENPAK-defined Customer Area, A0.77:A6'h. The actual block write will occur one byte at a time. The block write size controls cannot be used here, since the Customer Area block boundaries do not lie on page-write boundaries of the EEPROM, a feature of the XENPAK specification.

BYTE WRITES TO EEPROM SPACE

The second method is applicable to any part of the I²C space. The write operation is performed one byte at a time. The device address and memory address are written into the 1.32769

(1.8001'h) and 1.32770 (1.8002'h) registers respectively (see Table 16 and Table 17), and the data to be written into the 1.32772 (1.8004'h) register. On issuing a 'Write one byte' command (write 0022'h to 1.32768 = 1.8000'h) the data will be written into the I²C space. See Figure 23 for the timing sequence. Note that if the WRTP (Write Protect) pin is high, or the Write Size bit (1.32773.7 = 1.8005.7'h) is cleared to a '0', writes to any part of the basic NVR space outside the XENPAK-defined Customer Area will be ignored. Also note that a 16-bit addressable EEPROM (or equivalent) device on the I²C bus may be written by setting the Long Memory bit 1.32773.8 (1.8005.8'h) to a '1', and writing a full 16-bit memory address value into 1.32770 (1.8002'h). Note that this 16-bit operation MUST NOT be used on an 8-bit device.

These one-byte operations could be used to load modified Device Address values or protective passwords into multiple DOM devices, or for loading other types of data into them. They are also useful for writing data into I²C interface DCP devices for setting laser currents, etc.

MDIO Registers

In the following tables, the addresses are given in the table headers both in decimal (as used in the IEEE 802.3ae and 802.3ak documents) and in hexadecimal form. Where the registers coincide in structure and meaning, but the Device Addresses differ, the underlying register bits are the same, and may be read or written indiscriminately via any relevant Device Address. For instance a full RESET may be initiated by writing any one of 1.0.15, 3.0.15, or 4.0.15. While the reset is active, reading any of these bits would return a '1' (except that the reset lasts less than the MDIO preamble plus frame time). When the reset operation is complete, reading any of them will return a '0'. Note that extra preambles may be required after such a software RESET (see Figure 17).

Table 4. MDIO PMA/PMD DEVAD 1 REGISTERS

PMA/PMD DEVICE 1 MDIO REGISTERS							
ADDRESS		NAME	DESCRIPTION	DEFAULT	AC ⁽⁵⁾	R/W	DETAILS
DEC	HEX						
1.0	1.0	PMA/PMD Control 1	Reset, Enable serial loop back mode.	2040'h		R/W	Table 5
1.1	1.1	PMA/PMD Status 1	Local Fault and Link Status	0004'h ⁽²⁾		RO/LL	Table 6
1.2:3	1.2:3	ID Code	Manufacturer OUI & Device ID	01839C6V'h		RO	See ⁽¹⁾
1.4	1.4	Speed Abilty	PMA/PMD Speed Ability	0001'h		RO	Table 7
1.5	1.5	Dev in Pkg.	Devices in Package, Clause 22.	001A'h		RO	Table 8
1.6	1.6	Vend Sp Dev	Vendor Specific Devices in Package	0000'h		RO	Table 8
1.7	1.7	PMA/PMD Control 2	PMA/PMD type Selection	P ⁽⁴⁾		RO ⁽⁶⁾	Table 9
1.8	1.8	PMA/PMD Status 2	Fault Summary, Device Ability	B311'h ⁽²⁾		RO (LH)	Table 10
1.9	1.9	PMD TX Dis	Disable PMD Transmit	0000'h		R/W	Table 11
1.10	1.A	PMD Sig Det	PMD Signal Detect	001F'h ⁽²⁾		RO	Table 12

Table 4. MDIO PMA/PMD DEVAD 1 REGISTERS (Continued)

PMA/PMD DEVICE 1 MDIO REGISTERS							
ADDRESS		NAME	DESCRIPTION	DEFAULT	AC ⁽⁵⁾	R/W	DETAILS
DEC	HEX						
1.11	1.B	PMD Ext Ca	PMD Extended Capability	0001'h		RO	Table 13
1.14:15	1E:F	Pkg OUI	PMD Package OUI, etc.	00000000'h ⁽³⁾		R/W	Table 14
1.32768	1.8000	NVR Cntrl	NVR Control & Status Register	0003'h		R/W	Table 15
1.32769	1.8001	I ² C Dev Ad	1-Byte Operation Device Addr.	A2'h		R/W	Table 16
1.32770	1.8002	I ² C Mem Ad	1-Byte Operation Memory Addr.	0000'h		R/W	Table 17
1.32771	1.8003	I ² C RD Data	1-Byte Operation Read Data	0000'h		RO	Table 18
1.32772	1.8004	I ² C WR Data	1-Byte Operation Write Data	0000'h		R/W	Table 19
1.32773	1.8005	I ² C Op Ctl	I ² C Operation Control	004D'h		R/W	Table 20
1.32774	1.8006	I ² C Op Stts	I ² C Operation Status	0000'h		RO/LH	Table 21
1.32775: 33030	1.8007: 8106	NVR Copy Registers	XENPAK NVR Register Copies	Set by EEPROM		R/W	Table 22
1.36864	1.9000	RX AI Ctrl	RX ALARM Control	See Table ⁽⁴⁾	A	R/W	Table 24
1.36865	1.9001	TX AI Ctrl	TX ALARM Control	See Table ⁽⁴⁾	A	R/W	Table 25
1.36866	1.9002	LASI Ctrl	LASI Control	0000'h	A	R/W	Table 26
1.36867	1.9003	RX AI Stts	RX ALARM Status	0000'h ⁽²⁾		RO	Table 27
1.36868	1.9004	TX AI Stts	TX ALARM Status	0000'h ⁽²⁾		RO	Table 28
1.36869	1.9005	LASI Stts	LASI Status	0000'h ⁽²⁾		RO	Table 29
1.36870	1.9006	DOM TX	DOM TX_Flag Control	0000'h	A	R/W	Table 30
1.36871	1.9007	DOM RX	DOM RX_Flag Control	0000'h	A	R/W	Table 31
1.40960: 41215	1.A000 :A0FF	DOM Copy Registers	Alarm & Warning Thresholds, A/D Values, (cf SFF-8472)	Set by DOM devices		RO	Table 32: Table 37
1.41216	1.A100	DOM Ctrl	DOM Control & Status	0000'h		R/W	Table 38
1.49153	1.C001	PMA Ctrl2	PMA Control 2	0000'h	A	R/W	Table 39
1.49156	1.C004	PMA LB	PMA Loopback Control	0000'h	A	R/W	Table 40
1.49157	1.C005	PMA Pre	PMA Pre-emphasis Control	See Table ⁽⁴⁾	A	R/W	Table 41
1.49158	1.C006	PMA Eql	PMA Equalizer Boost Control	See Table ⁽⁴⁾	A	R/W	Table 43
1.49162	1.C00A	SIG_DET	Signal Detect Flags	0000'h ⁽²⁾		RO	Table 44
1.49163	1.C00B	Fine Tune	Adjust pre-emphasis, amplitude	See Table ⁽⁴⁾	A	R/W	Table 45
1.49167	1.C00F	Soft RST	Soft RESET	0000'h		R/W	Table 46
1.49168: 49171	1.C010 :C013	GPIO Cnfg	GPIO Config, Status & Alarm Registers	0000'h ⁽²⁾	A	R/W	Table 47: Table 50
1.49176	1.C018	DOM Control	DOM Control Register	0000'h	A	R/W	Table 51
1.49177:8	1.C019:A	DOM Mem	DOM Indirect Start Addresses	6060'h	A	R/W	Table 53
1.49179:80	1.C01B:C	DOM Dev	DOM Indirect Device Addresses	See Tables	A	R/W	Table 54
1.49181	1.C01D	StatusPolrty	LASI Alarm Pin Polarity	0000'h	A	R/W	Table 55

Note (1): 'V' is a version number. See "JTAG & AC-JTAG Operations" on page 53 for a note about the version number.

Note (2): Read values depend on status signal values. Values shown indicate 'normal' operation.

Note (3): If NVR load operation succeeds, will be overwritten by value loaded, see Table 22.

Note (4): Default value depends on CX4/LX4 select LX4_MODE Pin Value.

Note (5): For rows with "A", the default value may be overwritten by the Auto-Configure operation (See "Auto-Configuring Control Registers" on page 16 and Table 92 for details).

Note (6): IEEE 802.3 shows as R/W, but cannot write any other value than that set by LX4_MODE Pin.

IEEE PMA/PMD REGISTERS (1.0 TO 1.15/1.000F'H)

Table 5. IEEE PMA/PMD CONTROL 1 REGISTER

MDIO REGISTER ADDRESS = 1.0 (1.0000'h)					
BIT(S)	NAME	SETTING	DEFAULT	R/W	DESCRIPTION
1.0.15 3.0.15 4.0.15	Reset	1 = reset 0 = reset done, normal operation	0'b	R/W SC	Writing 1 to this bit will reset the whole chip, including the MDIO registers. ⁽¹⁾
1.0.14	Reserved		0'b		
1.0.13	Speed Select	1 = 10Gbps	1'b	RO	1 = bits 5:2 select speed
1.0.12	Reserved		0'b		
1.0.11	LOPOWER	0 = Normal Power	0'b	R/W	No Low Power Mode, writes ignored
1.0.10:7	Reserved		0'h		
1.0.6	Speed Select	1 = 10Gbps	1'b	RO	1 = bits 5:2 select speed
1.0.5:2	Speed Select	0000 = 10Gbps	0'h	RO	Operates at 10Gbps
1.0.1	Reserved		0'b		
1.0.0	PMA Loopback	1 = Enable loopback 0 = Normal operation	0'b	R/W	Enable serial loop back mode on all four lanes, XAUI in to XAUI out.

Note (1): After this RESET bit is written, the BBT3821 will not begin counting PREAMBLE bits immediately. See Figure 17 for details.

Table 6. IEEE PMA/PMD STATUS 1 REGISTER

MDIO REGISTER ADDRESS = 1.1 (1.0001'h)					
BIT	NAME	SETTING	DEFAULT	R/W	DESCRIPTION
1.1.15:8	Reserved		00'h		
1.1.7	Local Fault	1 = PMA Local Fault	0'b	RO	Derived from Register 1.8.11:10
1.1.6:3	Reserved		0'h		
1.1.2	Rx Link Up	1 = PMA Rx Link Up 0 = PMA/D Rx Link Down	1'b ⁽¹⁾	RO LL ⁽¹⁾	'Up' means CX4/LX4 signal level is OK, and the PLL locked
1.1.1	LoPwrAble	Low Power Ability	0'b	RO	Device does not support a low power mode
1.1.0	Reserved		0'b		

Note (1): This bit is latched low on a detected Fault condition. It is set high on being read.

Table 7. IEEE PMA/PMD, PCS, PHY XS, SPEED ABILITY REGISTER

MDIO REGISTER ADDRESSES = 1.4, 3.4 & 4.4 ([1,3,4].0004'h)					
BIT	NAME	SETTING	DEFAULT	R/W	DESCRIPTION
1.4.15:3 3.4.15:2 4.4.15:1	Reserved for future speeds		000'h		
1.4.2:1 3.4.1	10PASS-T2/ 2BASE-TL	EFM Ability	00'b	RO	Device cannot operate @ 2BASE-TL or 10PASS-T2
1.4.0 3.4.0 4.4.0	10GbpsAble	10Gbps Ability	1'b	RO	Device Able to operate @ 10Gbps

Table 8. IEEE DEVICES IN PACKAGE REGISTERS

MDIO REGISTER ADDRESSES = 1.5, 3.5, 4.5 ([1,3:4].0005'h)					
BIT	NAME	SETTING	DEFAULT	R/W	DESCRIPTION
[1,3:4].5.15:8	Reserved		000'h		
[1,3:4].5.7	Link Partner	Link Partner PMA/PMD present	0'b	RO	Device has no Link Partner
[1,3:4].5.6	10PASS-TS tone table	10PASS-TS tone table present	0'b	RO	Device has no 10PASS-TS tone table
[1,3:4].5.5	DTE XS	DTE XS Present	0'b	RO	Device ignores DEVAD 5
[1,3:4].5.4	PHY XS	PHY XS Present	1'b	RO	Device responds to DEVAD 4
[1,3:4].5.3	PCS	PCS Present	1'b	RO	Device responds to DEVAD 3
[1,3:4].5.2	WIS	WIS Present	0'b	RO	Device ignores DEVAD 2
[1,3:4].5.1	PMD_PMA	PMD/PMA Present	1'b	RO	Device responds to DEVAD 1
[1,3:4].5.0	Cls_22	Clause 22 registers	0'b	RO	Device ignores Clause 22
MDIO REGISTER ADDRESSES = 1.6, 3.6, 4.6 ([1,3:4].0006'h)					
[1,3:4].6.15	VndrDEV2	Vendor Specific DEV2	0'b	RO	Device ignores DEVAD 31
[1,3:4].6.14	VndrDEV1	Vendor Specific DEV1	0'b	RO	Device ignores DEVAD 30
[1,3:4].6.13	Clause 22 extrn.	Clause 22 extension	0'b	RO	Device has no Clause 22 extension
[1,3:4].6.12:0	Reserved		000'h		

Table 9. IEEE PMA/PMD TYPE SELECT REGISTER

MDIO REGISTER ADDRESSES = 1.7 (1.0007'h)					
BIT	NAME	SETTING	DEFAULT	R/W	DESCRIPTION
1.7.15:4	Reserved		000'h		
1.7.3:0	PMA/PMD Type	0100 = 10GBASE-LX4 0000 = 10GBASE-CX4	P'b ⁽¹⁾	RO	LX4_MODE select pin high is LX4 value, low is CX4 value

Note (1): Value depends on the current state of the LX4/CX4 select LX4_MODE pin. Although IEEE 802.3ae specifies R/W bits, only valid values may be written; since the pin controls the available valid value, no meaningful write is possible.

Table 10. IEEE PMA/PMD STATUS 2 DEVICE PRESENT & FAULT SUMMARY REGISTER

MDIO REGISTER ADDRESSES = 1.8 (1.0008'h)					
BIT	NAME	SETTING	DEFAULT	R/W	DESCRIPTION
1.8.15:14	Device present	10 = Device present	10'b	RO	When read as "10", it indicates that a device is present at this device address
1.8.13	TXLocalFit Ability	1 = PMA/PMD can detect TX Fault	1'b	RO	PMA/PMD has the ability to detect a Local Fault on Transmit Path
1.8.12	RXLocalFit Ability	1 = PMA/PMD can detect RX Fault	1'b	RO	PMA/PMD has the ability to detect a Local Fault on Receive Path
1.8.11	TXLocalFit	1 = TX Local Fault; on Egress channel	0'b	RO LH ⁽¹⁾	PLL lock fail (missing REFCLK) or TX_FAULT pin active
1.8.10	RXLocalFit	1 = RX Local Fault; on Ingress channel	0'b	RO LH ^(1,2)	PLL lock fail (missing REFCLK), or Loss of Signal in 1.10 (1.000A'h)
1.8.9	Ext Ability	1 = Extended Ability Register present.	1'b	RO	Device has Extended Ability Register in 1.11 (1.000B'h)
1.8.8	TX Disable	1 = Can Disable TX	1'b	RO	Device can Disable Transmitter
1.8.7	10GBASE-SR	0 = cannot perform	0'b	RO	Device cannot be 10GBASE-SR
1.8.6	10GBASE-LR	0 = cannot perform	0'b	RO	Device cannot be 10GBASE-LR

Table 10. IEEE PMA/PMD STATUS 2 DEVICE PRESENT & FAULT SUMMARY REGISTER (Continued)

MDIO REGISTER ADDRESSES = 1.8 (1.0008'h)					
BIT	NAME	SETTING	DEFAULT	R/W	DESCRIPTION
1.8.5	10GBASE-ER	0 = cannot perform	0'b	RO	Device cannot be 10GBASE-ER
1.8.4	10GBASE-LX4	1 = can perform	1'b	RO	Device can be 10GBASE-LX4
1.8.3	10GBASE-SW	0 = cannot perform	0'b	RO	Device cannot be 10GBASE-SW
1.8.2	10GBASE-LW	0 = cannot perform	0'b	RO	Device cannot be 10GBASE-LW
1.8.1	10GBASE-EW	0 = cannot perform	0'b	RO	Device cannot be 10GBASE-EW
1.8.0	PMA Loopback	1 = can perform	1'b	RO	Device can perform PMA loopback

Note (1): These bits are latched high on any Fault condition detected. They are reset low (cleared) on being read. They will also be reset low on reading the LASI registers 1.9003'h (bit 10, see Table 27) or 1.9004'h (bit 11, see Table 28).

Note (2): The source of 'Loss of Signal' depends on the LX4/CX4 select LX4_MODE pin (see register 1.10, 12, note (1) below).

Table 11. IEEE TRANSMIT DISABLE REGISTER

MDIO REGISTER ADDRESS = 1.9 (1.0009'h)					
BIT	NAME	SETTING	DEFAULT	R/W	DESCRIPTION
1.9.15:5	Reserved				
1.9.4	PMD Dis 3	Disable TX on Lane 3 ⁽¹⁾	0'b	R/W	1 = Disable PMD Transmit on respective Lane ⁽¹⁾ 0 = Enable PMD Transmit on respective Lane (unless TXON/OFF pin is Low)
1.9.3	PMD Dis 2	Disable TX on Lane 2 ⁽¹⁾	0'b	R/W	
1.9.2	PMD Dis 1	Disable TX on Lane 1 ⁽¹⁾	0'b	R/W	
1.9.1	PMD Dis 0	Disable TX on Lane 0 ⁽¹⁾	0'b	R/W	
1.9.0	PMD Dis All	Disable TX on all 4 Lanes	0'b	R/W	

Note (1): In CX4 mode the TCXnP/N pin outputs will be disabled; in LX4 Mode only TX_ENA[n] pin is disabled.

Table 12. IEEE PMD SIGNAL DETECT REGISTER

MDIO REGISTER ADDRESS = 1.10 (1.000A'h)					
BIT	NAME	SETTING	DEFAULT	R/W	DESCRIPTION
1.10.15:5	Reserved				
1.10.4	PMD Rx Ln 3	PMD Signal Det'd	1'b ⁽¹⁾	RO	1 = PMD Signal Detected on respective Lane (Global, all Lanes) 0 = PMD Signal not detected on respective Lane (Global, any Lane)
1.10.3	PMD Rx Ln 2	PMD Signal Det'd	1'b ⁽¹⁾	RO	
1.10.2	PMD Rx Ln 1	PMD Signal Det'd	1'b ⁽¹⁾	RO	
1.10.1	PMD Rx Ln 0	PMD Signal Det'd	1'b ⁽¹⁾	RO	
1.10.0	PMD Rx Glob	PMD Signal Det'd	1'b ⁽¹⁾	RO	

Note (1): These bits reflect the OPRLOS[3:0] pins (Table 99) in LX4 mode, or the CX4 SIGNAL_DETECT function in CX4 mode, depending on the LX4_MODE select pin.

Table 13. IEEE EXTENDED PMA/PMD CAPABILITY REGISTER⁽¹⁾

MDIO Register Addresses = 1.11 (1.000B'h)					
BIT	NAME	SETTING	DEFAULT	R/W	DESCRIPTION
1.11.15:1	Reserved		0000'h	RO	
1.11.0 ⁽¹⁾	10GBASE-CX4	1 = can perform	1'b	RO	Device can be 10GBASE-CX4

Note (1): These values reflect the IEEE 802.3ak 10GBASE-CX4 specification.

Table 14. IEEE PACKAGE IDENTIFIER REGISTERS

MDIO REGISTER ADDRESSES = 1.14:15 (1.000E:F'h)					
BIT	NAME	SETTING	DEFAULT	R/W	DESCRIPTION
1.14.15:0	Package ID	Package OUI bits 3:24 & etc.	00'h	R/W	If NVR is loaded, these are copies of 1.32818:32819 (1.8032:8033'h) & 1.32820:32821 (1.8034:8035'h)
1.15.15:0	Package ID		00'h	R/W	

XENPAK-DEFINED REGISTERS (1.8000'H TO 1.8106'H)**Table 15. XENPAK NVR CONTROL & STATUS REGISTER**

MDIO (XENPAK) REGISTER ADDRESS = 1.32768 (1.8000'h)					
BIT	NAME	SETTING	DEFAULT	R/W	DESCRIPTION
1.32768.15:6	Reserved		000'h	R/W	
1.32768.5	NVR Command ⁽¹⁾	1 = Write NVR 0 = Read NVR	0'b ⁽²⁾	R/W	Write/Read Control for I ² C operation
1.32768.4	Reserved		0'b	RO	
1.32768.3:2	NVR Command Status ⁽³⁾	Current Status of NVR Command	00'b	RO	11 = Command failed 10 = Command in progress/Queued 01 = Command completed with success 00 = Idle
1.32768.1:0	Extended NVR Command	NVR operation to be performed	11'b ⁽²⁾	R/W	10 = read/write one byte ⁽³⁾ 11 = read/write all NVR contents ⁽³⁾ Other values = reserved

Note (1): User writes to these bits are not valid unless the Command Status is Idle. The Command Status will not return to Idle until read after command completion (either Succeed or Failed).

Note (2): At the end of a hardware RESET via the RSTN pin, on powerup, or on a register [1,3,4].0.15 RESET operation, and if the XP_ENA pin is asserted, the BBT3821 will automatically begin an 'all NVR read' operation.

Note (3): The single byte commands are controlled through the bits of the registers at 1.32769:32774 (1.8001:8006'h). The 'block write/read' commands are affected by register 1.32773 (1.8005'h). Additional status is available in 1.327743 (1.8006'h)

Table 16. I²C ONE-BYTE OPERATION DEVICE ADDRESS REGISTER

MDIO REGISTER ADDRESS = 1.32769 (1.8001'h)					
BIT	NAME	SETTING	DEFAULT	R/W	DESCRIPTION
1.32769.15:8	Reserved		00'h	RO	
1.32769.7:0	Device Address	I ² C Device address to access	A2'h	R/W	All I ² C Device addresses are even. Bit 0 cannot be set.

Table 17. I²C ONE-BYTE OPERATION MEMORY ADDRESS REGISTER

MDIO REGISTER, ADDRESS = 1.32770 (1.8002'h)					
BIT	NAME	SETTING	DEFAULT	R/W	DESCRIPTION
1.32770.15:0	Memory Address	I ² C Memory address to access	0000'h ⁽²⁾	R/W	I ² C Memory Address within Device address of 1.32769 (1.8001'h)

Note (1): 8-bit-addressed I²C devices are addressed using bits 7:0. Never set bit 1.32773.8 (1.8005'h.8) for 16-bit address operation with an 8-bit address I²C device.

Table 18. I²C ONE-BYTE OPERATION READ DATA REGISTER

MDIO REGISTER ADDRESS = 1.32771 (1.8003'h)					
BIT	NAME	SETTING	DEFAULT	R/W	DESCRIPTION
1.32771.15:8	Reserved		00'h	RO	
1.32771.7:0	Read Data	I ² C Read Data	00'h	RO	Result of I ² C 1-byte Read operation

Table 19. I²C ONE-BYTE OPERATION WRITE DATA REGISTER

MDIO Register Address = 1.32772 (1.8004'h)					
BIT	NAME	SETTING	DEFAULT	R/W	DESCRIPTION
1.32772.15:8	Reserved		00'h	RO	
1.32772.7:0	Write Data	I ² C Write Data	00'h	R/W	Data to be written by 1-byte Write Operation

Table 20. NVR I²C OPERATION CONTROL REGISTER

MDIO REGISTER ADDRESS = 1.32773 (1.8005'h)					
BIT	NAME	SETTING	DEFAULT	R/W	DESCRIPTION
1.32773.15:9	Reserved		00'h	RO	
1.32773.8	Long Memory ⁽¹⁾	1 = 16 bit 0 = 8 bit	0'b	R/W	Length of address for I ² C device selected
1.32773.7	NVR Write Size		0'b	R/W	1 = Block write all 256 bytes to NVR ⁽²⁾ 0 = Write only 1.807F:AE'h to NVR ⁽³⁾
1.32773.6:4	I ² C Bus Speed	Speed of I ² C SCL clock ⁽⁴⁾ (derived from REF_CLOCK)	100'b	R/W	111 = 400kHz 110 = 200kHz 101 = 150kHz 100 = 100kHz 011 = 40kHz 010 = 20kHz 001 = 10kHz 000 = 4kHz
1.32773.3:2	NVR ACK Error Count	11 = 63 10 = 16 01 = 4 00 = 1	11'b	R/W	Number of ACK failures at any address before I ² C Operation failure is reported
1.32773.1:0	NVR Write Page Size ⁽²⁾	11 = 32 bytes 10 = 16 bytes 01 = 8 bytes 00 = 4 byte	01'b	R/W	The I ² C interface block write operation will issue a STOP and wait for the EEPROM every time after this number of bytes are sent out

Note (1): This bit should only be set if an I²C device which needs a 16-bit address is to be addressed. The NVR and DOM spaces are all 8-bit address sections, and for these areas, this bit should be 0'b.

Note (2): Block 256-byte NVR writes will not occur unless the WRTP pin is set Low. NVR Write Page Size controls Page size for Block operations only.

Note (3): This area corresponds to the XENPAK-defined Customer Area; see XENPAK Spec R3.0 Section 10.12.22. Writes will be performed one byte at a time.

Note (4): The I²C clock speeds listed are approximate. They are derived by division from the CMU, locked to the RFCP/N inputs. At 156.25MHz, the nominal 100kHz clock will actually be 156.25/1.6kHz, just over 97.5kHz. See also the notes to Table 117.

Table 21. NVR I²C OPERATION STATUS REGISTER

MDIO REGISTER ADDRESS = 1.32774 (1.8006'h)					
BIT	NAME	SETTING	DEFAULT	R/W	DESCRIPTION
1.32774.15	XP_ENA	XP_ENA pin		RO	1 = XP_ENA pin high, 0 = low
1.32774.14:4	Reserved		0000'h	RO	
1.32774.3	Vendor Specific Area EXOR sum check	Error Flag	0'b	RO LH	1 = 1.8106 != EXOR(1.80AE:8105) 0 = 1.8106 = EXOR(1.80AE:8105) ⁽²⁾
1.32774.2	Customer Write Area EXOR sum check	Error Flag	0'b	RO LH	1 = 1.80AD != EXOR(1.807E:80AC) 0 = 1.80AD = EXOR(1.807E:80AC) ⁽²⁾
1.32774.1	Reserved		0'b	RO LH ⁽¹⁾	
1.32774.0	NVR Area EXOR sum check	Error Flag	0'b	RO LH	1 = 1.807D != EXOR(1.8007:807C) 0 = 1.807D = EXOR(1.8007:807C) ⁽²⁾

Note (1): These bits are latched high on any internal error condition detected. They are reset low (cleared) on being read.

Note (2): These bits are set if the EXOR sum calculated from the indicated range is not the same as the value read into the listed checksum register. Note that this is NOT the same as the XENPAK-defined checksum calculation. Contact Intersil for a method of reconciling these two checksum calculations.

Table 22. XENPAK NVR REGISTER COPY

MDIO XENPAK/XPAK/X2 NVR REGISTER ADDRESSES = 1.32775:33030 (1.8007:8106'h)						
BYTE ADDRESS		NAME	DESCRIPTION ⁽¹⁾	SUGGESTED VALUE	R/W	DETAILS
DEC	HEX					
1.32775 to 1.32817	1.8007 to 1.8031	NVR Register Copy	XENPAK NVR Register Copies		R/W ⁽²⁾	
1.32818 to 1.32821	1.8032 to 1.8035	PKG OUI	XENPAK/XPAK/X2 Package OUI (bits 3 to 24)	Xenpak = 0008BE XPAK = 000ACB X2 = 000C64	R/W ⁽²⁾	Mirrored to 1.14:15 (1.E:F'h)
1.32822 to 1.32889	1.8036 to 1.8079	NVR Register Copy	XENPAK NVR Register Copies		R/W ⁽²⁾	
1.32890	1.807A	DOM Ctrl	DOM Capability Bits		R/W ⁽²⁾	Table 23
1.32891 1.32892	1.807B 1.807C	NVR Reg Copy	XENPAK NVR Register Copies		R/W ⁽²⁾	
1.32893	1.807D	Basic Chksum	Basic Field Checksum ⁽³⁾	$\Sigma(1.8007:807C)$		
1.32894 to 1.32940	1.807E to 1.80AC	NVR Register Copy	Customer Writable Area ⁽⁴⁾		R/W ⁽²⁾	
1.32941	1.80AD	Cstm Chksum	Customer Area Checksum ⁽⁵⁾	$\Sigma(1.807E:80AC)$		
1.32942 to 1.33027	1.80AE to 1.8103	NVR Register Copy	Vendor Specific Area		R/W ⁽²⁾	
1.33028	1.8104	A/C Size	Auto-configure Size (N)	See page 16 (or 00 or FF'h)		See Table 92
1.33029	1.8105	A/C Pointer	Auto-configure Pointer (S)			
1.33030	1.8106	Vndr Chksum	Vendor Specific Checksum ⁽⁶⁾	$\Sigma(1.80AE:8105)$		

Note (1): Only register values operated on by the BBT3821 are individually listed. The others are merely copied from the I²C NVR space.

Note (2): Although data can be written to these registers, it will be volatile, unless the 'Write NVR' operation as specified in "Writing EEPROM Space through the I2C Interface" on page 19 is performed.

Note (3): Checksum to be calculated from 1.8007'h to 1.807C'h. Host can check for validity.

Note (4): If WRTP pin is high, this is the only area that can be written by the user. See also Note (2) above.

Note (5): Checksum to be calculated from 1.807E'h to 1.80AC'h.

Note (6): Checksum to be calculated from 1.80AE'h to 1.8105'h.

Table 23. XENPAK DIGITAL OPTICAL MONITORING (DOM) CAPABILITY REGISTER

MDIO (XENPAK) REGISTER, ADDRESS = 1.32890 (1.807A'h)					
BIT	NAME	SETTING	SUGGESTED VALUE ⁽¹⁾	R/W ⁽³⁾	DESCRIPTION
1.32890.15:8	Reserved		000'h		
1.32890.7	DOM Ctrl Reg	1 = Implemented 0 = Not implemented	1'b	R/W	DOM Control/Status Register 1.A100'h
1.32890.6	DOM system		1'b	R/W	DOM Implemented
1.32890.5	Lane-by Lane		1'b	R/W	WDM Lane-by-Lane DOM; registers 1.A0C0:A0FF'h valid
1.32890.4	LBC Scale	1 = 10 μ A 0 = 2 μ A		R/W	Laser Bias Scale Factor
1.32890.3	Reserved				
1.32890.2:0	DOM Address		001'b	R/W	I ² C Device Address of (initial) DOM IC ⁽²⁾

Note (1): Suggested values are given, for a full LX4 module with four individual-lane DOM circuits, at least one having the DOM data at Device Address A2'h.

Note (2): Last three significant bits of the (default) DOM I²C Device Address (NB LSB is a read/write flag). Upper bits are assumed to be '1010'b, Device address will be (A0'h + 2*(<1.32890.2:0>)). A device MUST be present at this address for correct operation if bit 6 is set.

Note (3): Although data can be written to this register, it should only be done for writing the NVR, using the 'Write NVR' operation as specified in "Writing EEPROM Space through the I2C Interface" on page 19. The values here should normally only be loaded from the NVR, since they could affect the operation of the BBT3821 if incorrect.

XENPAK LASI AND DOM REGISTERS (1.9000'H TO 1.9007'H & 1.A000'H TO 1.A100'H)**Table 24. XENPAK LASI RX_ALARM CONTROL REGISTER**

MDIO REGISTER, ADDRESS = 1.36864 (1.9000'h)					
BIT	NAME	SETTING	DEFAULT ⁽¹⁾	R/W	DESCRIPTION
1.36864.15:7	Reserved		000'h		
1.36864.6	PCS Byte S	1 = trigger LASI by corresponding bit of 1.36867 (1.9003'h) 0 = LASI ignores corresponding bit of 1.36867 (1.9003'h)	0'b	R/W	PCS Byte Sync Fail LASI Enable
1.36864.5	RX Power		1'b	R/W	Receive Laser Pwr/Sig Det LASI Enable
1.36864.4	PMA LF		1'b	R/W	PMA RX Local Fault LASI Enable
1.36864.3	PCS LF		1'b	R/W	PCS RX Local Fault LASI Enable
1.36864.2	PCS Code		0'b/1'b	R/W	8b/10b Code Violation LASI Enable
1.36864.1	DOM RX		1'b	R/W	DOM RX or RX EFIFO Fault LASI Enable
1.36864.0	PHY RX LF		1'b	R/W	PHY RX Local Fault LASI Enable

Note (1): Where two values are given, Default depends on LX4/CX4 select LX4_MODE pin. First value is LX4 value. The value may be overwritten by the Auto-Configure operation (See "Auto-Configuring Control Registers" on page 16 and Table 92 for details).

Table 25. XENPAK LASI TX_ALARM CONTROL REGISTER

MDIO REGISTER, ADDRESS = 1.36865 (1.9001'h)					
BIT	NAME	SETTING	DEFAULT ⁽¹⁾	R/W	DESCRIPTION
1.36865.15:11	Reserved		000'h		
1.36865.10	PHY S_D	1 = trigger LASI from corresponding bit of 1.36868 (1.9004'h) 0 = LASI ignores corresponding bit of 1.36868 (1.9004'h)	0'b/1'b	R/W	PHY XS Signal Detect LASI Enable
1.36865.9	LBC		1'b/0'b	R/W	Laser Bias Current Fault LASI Enable
1.36865.8	LTEMP		1'b/0'b	R/W	Laser Temperature Fault LASI Enable
1.36865.7	LOP		1'b/0'b	R/W	Laser Output Power Fault LASI Enable
1.36865.6	TX LF		1'b/0'b	R/W	Transmit Local Fault LASI Enable
1.36865.5	Byte Sync		0'b/1'b	R/W	PHY XS Byte Sync Fail LASI Enable
1.36865.4	PMA LF		1'b	R/W	PMA TX Local Fault LASI Enable
1.36865.3	PCS LF		1'b/0'b	R/W	PCS TX Local Fault LASI Enable
1.36865.2	TX EFIFO		0'b/1'b	R/W	Transmit EFIFO Error LASI Enable
1.36865.1	DOM TX/ PHY Code		1'b	R/W	DOM TX or PHY XS 8b/10b Code Violation Fault LASI Enable
1.36865.0	PHY TX LF		1'b	R/W	PHY TX Local Fault LASI Enable

Note (1): Where two values are given, Default depends on LX4/CX4 select LX4_MODE pin. First value is LX4 value. The value may be overwritten by the Auto-Configure operation (See "Auto-Configuring Control Registers" on page 16 and Table 92 for details).

Table 26. XENPAK LASI CONTROL REGISTER

MDIO REGISTER, ADDRESS = 1.36866 (1.9002'h)					
BIT	NAME	SETTING	DEFAULT ⁽¹⁾	R/W	DESCRIPTION
1.36866.15:4	Reserved		000'h		
1.36866.3	GPIO	1 = trigger LASI via bit in 1.36869 (1.9005'h) 0 = LASI ignores bit	0'b	R/W	Enable GPIO pins to trigger LASI ⁽²⁾
1.36866.2	RX_Alarm		0'b	R/W	Enable RX_Alarm to trigger LASI
1.36866.1	TX_Alarm		0'b	R/W	Enable TX_Alarm to trigger LASI
1.36866.0	LS_Alarm		0'b	R/W	Enable Link Status change to trigger LASI

Note (1): The default values may be overwritten by the Auto-Configure operation (See "Auto-Configuring Control Registers" on page 16 and Table 92 for details). Since on Power up or RESET several LASI contributors will initially be in the 'fault' condition (in particular, Byte Synch and Lane Alignment, and their derivatives), it may be advisable for a host to clear these before enabling these to trigger LASI.

Note (2): See description of the General Purpose Input/Output (GPIO) pins and bits for a description of how they contribute to the LASI system.

Table 27. XENPAK LASI RX_ALARM STATUS REGISTER

MDIO REGISTER, ADDRESS = 1.36867 (1.9003'h)					
BIT	NAME	SETTING	DEFAULT	R/W	DESCRIPTION ⁽¹⁾
1.36867.15:6	Reserved		000'h		
1.36867.6	PCS Byte Synch	1 = Alarm Condition is Detected 0 = No Alarm Condition is Detected	0'b	RO/LH	PCS Byte Sync Fail (logical NAND of bits 3.24.[3:0])
1.36867.5	RX Receive Power/Level		0'b	RO/LH	LX4: Receive Laser Power from OPRXOP pin (for polarity see 1.49181) CX4: Loss of Signal Detect ⁽³⁾
1.36867.4	PMA LF		0'b	RO/LH	PMA/PMD RX Local Fault: mirror to bit 1.8.10 ⁽²⁾
1.36867.3	PCS LF		0'b	RO/LH	PCS RX Local Fault: mirror to bit 3.8.10 ⁽²⁾
1.36867.2	PCS Code		0'b	RO/LH	PCS 8b/10b Code Violation in any lane of PCS
1.36867.1	DOM RXFlg/ RX EFIFO		0'b	RO/LH	LX4: DOM RX_Flag (from polling) CX4: RX EFIFO over/underflow Fault
1.36867.0	PHY RX LF		0'b	RO/LH	PHY RX Local Fault Status: mirror to bit 4.8.10 ⁽²⁾

Note (1): Where two descriptions are given, depends on LX4/CX4 select LX4_MODE pin. First value is LX4 value

Note (2): These mirrored bits will be cleared on a read of either this register or of their respective mirroring registers.

Note (3): This bit is derived from the OR of the LOS bits (1.C00A.3:0). In the case of a signal which is close to the LOS threshold value, so that LOS is changing over time for one or more lanes, this bit may give a "FAIL" indication even though the SIGNAL_DETECT function declares the signal "GOOD", and Byte Synch and Lane Align all indicate a "GOOD" signal.

Table 28. XENPAK LASI TX_ALARM STATUS REGISTER

MDIO REGISTER, ADDRESS = 1.36868 (1.9004'h)					
BIT	NAME	SETTING	DEFAULT	R/W	DESCRIPTION ⁽¹⁾
1.36868.15:11	Reserved		000'h		
1.36868.10	PHY S_D	1 = Alarm Condition is Detected 0 = No Alarm Condition is Detected	0'b	RO/ LH	LX4: No fail detected CX4: PHY XS Signal Detect Fail (XAUI)
1.36868.9	LBC		0'b	RO LH	LX4: Laser Bias Current Fault (from OPTXLBC pin, for polarity see 1.49181) CX4: No failure detectable
1.36868.8	LTEMP		0'b	RO LH	LX4: Laser Temperature Fault (from OPTTEMP pin, for polarity see 1.49181) CX4: No failure detectable
1.36868.7	LOP		0'b	RO LH	LX4: Laser Output Power Fault (from OPTXLOP pin, for polarity see 1.49181) CX4: No failure detectable
1.36868.6	TX LF		0'b	RO LH	Transmit Local Fault (from TX_FAULT pin, for polarity see 1.49170)
1.36868.5	Byte Sync		0'b	RO LH	LX4: No fail detected CX4: PHY XS Byte Sync Fail Status
1.36868.4	PMA LF		0'b	RO LH	PMA TX Local Fault Status: mirror to bit 1.8.11 ⁽²⁾
1.36868.3	PCS LF		0'b	RO LH	LX4: PCS TX Local Fault Status: mirror to bit 3.8.11 ⁽²⁾ CX4: No failure detectable
1.36868.2	TX EFIFO		0'b	RO LH	LX4: No fail detected CX4: Transmit EFIFO Error Status
1.36868.1	DOM TX/ PHY Code		0'b	RO LH	LX4: DOM TX_Flag (from polling) CX4: PHY XS 8b/10b Code Violation
1.36868.0	PHY TX LF		0'b	RO LH	PHY TX Local Fault Status: mirror to bit 4.8.11 ⁽²⁾

Note (1): Where two descriptions are given, depends on LX4/CX4 select LX4_MODE pin. First value is LX4 value

Note (2): These mirrored bits will be cleared on read of either this register or their respective registers.

Table 29. XENPAK LASI STATUS REGISTER

MDIO REGISTER, ADDRESS = 1.36869 (1.9005'h)					
BIT	NAME	SETTING	DEFAULT	R/W	DESCRIPTION
1.36869.15:4	Reserved		000'h		
1.36869.3	GPIO Alarm	1 = Alarm Condition is Detected	0'b	RO	Logic OR of signals in register 1.49169.[15:8] (1.C011h), which come from GPIO pins.
1.36869.2	RX_ALARM	0 = No Alarm Condition is Detected	0'b	RO	Logic OR of signals in register 1.36867 RX_ALARM Status register
1.36869.1	TX_ALARM		0'b	RO	Logic OR of signals in register 1.36868 TX_ALARM Status register
1.36869.0	LS_ALARM		0'b	RO LH ⁽¹⁾	Link Status Logic change in AND of "PMD Signal OK" (1.10.0), "PCS Lane Alignment" (3.24.12), and "PHY XS Lane Alignment" (4.24.12)

Note (1): This bit is latched high on any change in the condition detected. It is reset low (cleared) on being read.

Table 30. XENPAK DOM TX_FLAG CONTROL REGISTER

MDIO REGISTER, ADDRESS = 1.36870 (1.9006'h)					
BIT ⁽¹⁾	NAME	SETTING	DEFAULT ⁽²⁾	R/W	DESCRIPTION
1.36870.15:8	Reserved		000'h		
1.36870.7	TTmp_Hi	1 = Enable Alarm 0 = Disable Alarm	0'b	R/W	Transceiver Temp High Alarm Enable
1.36870.6	TTmp_Lo		0'b	R/W	Transceiver Temp Low Alarm Enable
1.36870.5:4	Reserved		0'h	R/W	
1.36870.3	LBC_Hi	1 = Enable Alarm 0 = Disable Alarm	0'b	R/W	Laser Bias Current High Alarm Enable
1.36870.2	LBC_Lo		0'b	R/W	Laser Bias Current Low Alarm Enable
1.36870.1	LOP_Hi		0'b	R/W	Laser Output Power High Alarm Enable
1.36870.0	LOP_Lo		0'b	R/W	Laser Output Power Low Alarm Enable

Note (1): These bits control (select) alarm signals (bits) in register 1.41072 (1.A070'h) to generate the TX_Flag bit of register 1.36868 (1.9004'h) to trigger TX_ALARM and hence LASI.

Note (2): The default values may be overwritten by the Auto-Configure operation (See "Auto-Configuring Control Registers" on page 16 and Table 92 for details).

Table 31. XENPAK DOM RX_FLAG CONTROL REGISTER

MDIO REGISTER, ADDRESS = 1.36871 (1.9007'h)					
BIT ⁽¹⁾	NAME	SETTING	DEFAULT ⁽²⁾	R/W	DESCRIPTION
1.36871.15:8	Reserved		000'h		
1.36871.7	ROP_Hi	1 = Enable Alarm 0 = Disable Alarm	0'b	R/W	Receive Optical Power High Alarm Enable
1.36871.6	ROP_Lo		0'b	R/W	Receive Optical Power Low Alarm Enable
1.36871.5:0	Reserved		00'h		

Note (1): These bits control (select) alarm signals (bits) in register 1.41073 (1.A071'h) to generate the RX_Flag bit of register 1.36867 (1.9003'h) to trigger RX_ALARM and hence LASI.

Note (2): The default value may be overwritten by the Auto-Configure operation (See "Auto-Configuring Control Registers" on page 16 and Table 92 for details).

Table 32. XENPAK DOM ALARM & WARNING THRESHOLD REGISTERS COPY

XENPAK/XPAK/X2 DOM REGISTERS = 1.40960:40999 & 41032:41055 (1.A000:A027'h & A048:A05F'h) ⁽¹⁾						
BYTE ADDRESS		MEMORY ADDRESS	DESCRIPTION	DEFAULT	R/W	DETAILS
DEC	HEX					
1.40960 to 1.40967	1.A000 to 1.A007	00 to 07	Transceiver Temp High & Low Alarm & Warning Thresholds		RO	Byte Order: High Alarm MSB:LSB Low Alarm MSB:LSB High Warning MSB:LSB Low Warning MSB:LSB
1.40968 to 1.40975	1.A008 to 1.A00F	08 to 15	Reserved		RO	
1.40976 to 1.40983	1.A010 to 1.A017	16 to 23	Laser Bias Current High & Low Alarm & Warning Thresholds (Lane 0 or common to all lanes)		RO	
1.40984 to 1.40991	1.A018 to 1.A01F	24 to 31	Laser Output Power High & Low Alarm & Warning Thresholds		RO	
1.40992 to 1.40099	1.A020 to 1.A027	32-39	Receive Optical Power High & Low Alarm & Warning Thresholds		RO	
1.41032 to 1.41055	1.A048 to 1.A05F	72 to 95	Lane-by-Lane Laser Bias Current High & Low Alarm & Warning Thresholds (or Zero)		RO	

Note (1): These 1-byte register values are merely copied by the BBT3821 from the I²C address space on Power-up or RESET, or on a periodic direct DOM update operation (i.e. with Register bit 1.C018'h.2 Table 51 not set) under the control of Register 1.A100'h (Table 38). For further details see Table 27 in the XENPAK MSA Rev 3.0 specification, especially Note 2. If it is desired to write this data into a DOM device through the MDIO interface, it will need to be written one byte at a time via the methods discussed in "MDIO Register Addressing" on page 15.

Table 33. XENPAK DOM MONITORED A/D VALUES REGISTER COPY

MDIO XENPAK/XPAK/X2 DOM REGISTER ADDRESSES = 1.41056:41069 & 1.41152:41215 (1.A060:A06D'h & 1.A0C0:A0FF)						
BYTE ADDRESS		MEMORY ADDRESS	DESCRIPTION ⁽¹⁾	DEFAULT	R/W	DETAILS
DEC	HEX					
1.41056 1.41057	1.A060 1.A061	96 & 97	"Farthest out of range/Representative" Transceiver Temperature ⁽²⁾		RO	MSB:LSB
1.41058 1.41059	1.A062 1.A063	98 & 99	Reserved			
1.41060 1.41061	1.A064 1.A065	100 & 101	"Farthest out of range/Representative" Laser Bias Current ⁽²⁾		RO	MSB:LSB
1.41062 1.41063	1.A066 1.A067	102 & 103	"Farthest out of range/Representative" Laser Output Power ⁽²⁾		RO	MSB:LSB
1.41064 1.41065	1.A068 1.A069	104 & 105	"Farthest out of range/Representative" Receive Optical Power ⁽²⁾		RO	MSB:LSB
1.41066 - 1.41069	1.A06A to 1.406D	106 to 109	Reserved			
1.41070 to 1.41077	1.A06E to 1.A075	110 to 117	DOM Status, Capability, and Alarm Flags ⁽²⁾ . See Table 34 to Table 37		RO	
1.41078 to 1.41151	1.A076 to 1.A0BF	118 to 191	Reserved			
1.41152:3	1.A0C0:1	192:193	Lane 0 Transceiver Temperature ⁽³⁾		RO	MSB:LSB
1.41154:5	1.A0C2:3	194:195	Reserved		RO	MSB:LSB
1.41156:7	1.A0C4:5	196:197	Lane 0 Laser Bias Current ⁽³⁾		RO	MSB:LSB
1.41158:9	1.A0C6:7	198:199	Lane 0 Laser Output Power ⁽³⁾		RO	MSB:LSB
1.41160:1	1.A0C8:9	200:201	Lane 0 Receive Optical Power ⁽³⁾		RO	MSB:LSB
1.41162:7	1.A0CA:F	202:207	Reserved			
1.41168:9	1.A0D0:1	208:209	Lane 1 Transceiver Temperature ⁽³⁾		RO	MSB:LSB

Table 33. XENPAK DOM MONITORED A/D VALUES REGISTER COPY (Continued)

MDIO XENPAK/XPAK/X2 DOM REGISTER ADDRESSES = 1.41056:41069 & 1.41152:41215 (1.A060:A06D'h & 1.A0C0:A0FF)						
BYTE ADDRESS		MEMORY ADDRESS	DESCRIPTION ⁽¹⁾	DEFAULT	R/W	DETAILS
DEC	HEX					
1.41170:1	1.A0D2:3	210:211	Reserved		RO	MSB:LSB
1.41172:3	1.A0D4:5	212:213	Lane 1 Laser Bias Current ⁽³⁾		RO	MSB:LSB
1.41174:5	1.A0D6:7	214:215	Lane 1 Laser Output Power ⁽³⁾		RO	MSB:LSB
1.41176:7	1.A0D8:9	216:217	Lane 1 Receive Optical Power ⁽³⁾		RO	MSB:LSB
1.41178:83	1.A0DA:F	218:223	Reserved			
1.41184:5	1.A0E0:1	224:225	Lane 2 Transceiver Temperature ⁽³⁾		RO	MSB:LSB
1.41186:7	1.A0E2:3	226:227	Reserved		RO	MSB:LSB
1.41188:9	1.A0E4:5	228:229	Lane 2 Laser Bias Current ⁽³⁾		RO	MSB:LSB
1.41190:1	1.A0E6:7	230:231	Lane 2 Laser Output Power ⁽³⁾		RO	MSB:LSB
1.41192:3	1.A0E8:9	232:233	Lane 2 Receive Optical Power ⁽³⁾		RO	MSB:LSB
1.41194:9	1.A0EA:F	234:239	Reserved			
1.41200:1	1.A0F0:1	240:241	Lane 3 Transceiver Temperature ⁽³⁾		RO	MSB:LSB
1.41202:3	1.A0F2:3	242:243	Reserved		RO	MSB:LSB
1.41204:5	1.A0F4:5	244:245	Lane 3 Laser Bias Current ⁽³⁾		RO	MSB:LSB
1.41206:7	1.A0F6:7	246:247	Lane 3 Laser Output Power ⁽³⁾		RO	MSB:LSB
1.41208:9	1.A0F8:9	228:249	Lane 3 Receive Optical Power ⁽³⁾		RO	MSB:LSB
1.41210:5	1.A0FA:F	250:255	Reserved			

Note (1): These 1-byte register values are merely copied by the BBT3821 from the I²C address space on RESET (if enabled), on demand, or periodically under the control of Register 1.A100'h (Table 38).

Note (2): If the 'Indirect DOM Enable' bit (Register bit 1.C018'h.2 Table 51) is not set, a four-lane external DOM device is expected to determine the "Farthest out of range" or "Representative" values for these registers, according to the rules of Note 1 to Table 28 in the XENPAK MSA Rev 3.0 specification. A single one-lane DOM device system will provide the values from the single DOM device here only. If the 'Indirect DOM Enable' bit is set, "Representative" is defined by Register bits 1.C018'h.1:0 (Table 51), and the values from the specified lane's DOM are entered here also.

Note (3): If the 'Indirect DOM Enable' bit (Register bit 1.C018'h.2 Table 51) is not set, a four-lane external DOM device is expected to provide the Lane-by-Lane data. For a single one-lane DOM device system these values are 00'h. The Lane-by-Lane data is obtained from the I²C address space via the pointers defined in Registers 1.C019:C'h (Table 53 & Table 54), if the 'Indirect DOM Enable' bit is set (Register 1.C018'h Table 51).

Table 34. XENPAK OPTIONAL DOM STATUS BITS REGISTER

MDIO REGISTER, ADDRESS = 1.41070 (1.A06E'h)					
BIT	NAME	SETTING	DEFAULT	R/W	DESCRIPTION ⁽¹⁾
1.41070.15:1	Reserved		0000'h		
1.41070.0	Data_Ready_Bar	1 = Not Ready 0 = Ready	0'b ⁽²⁾	RO	High during power-up and first NVR/DOM read. After that set low.

Note (1): This 1-byte register value is merely copied by the BBT3821 from the I²C address space on Power-up or RESET, or on a periodic or on-demand direct DOM update operation (i.e. with Register bit 1.C018'h.2 Table 51 not set) under the control of Register 1.A100'h (Table 38). The BBT3821 takes no action as a result of the values copied.

Note (2): Assumes NVR/DOM read succeeds

Table 35. XENPAK DOM EXTENDED CAPABILITY REGISTER

MDIO REGISTER, ADDRESS = 1.41071 (1.A06F'h)					
BIT	NAME	SETTING	DEFAULT	R/W	DESCRIPTION ⁽¹⁾
1.41071.15:8	Reserved		00'h ⁽¹⁾		
1.41071.7	TT_Able	1 = Indicates Capability Implemented 0 = Not Implemented		RO	Transceiver Temp Monitoring Capable
1.41071.6	LBC_Able			RO	Laser Bias Current Monitoring Capable
1.41071.5	LOP_Able			RO	Laser Output Power Monitoring Capable
1.41071.4	ROP_Able			RO	Receive Optical Power Monitoring Capable
1.41071.3	AL_Able			RO	Alarm Flags for Monitored Quantities
1.41071.2	WN_Able			RO	Warning Flags for Monitored Quantities
1.41071.1	MON_LASI			RO	Monitoring Quantities Input to LASI
1.41071.0	Reserved			RO	Monitoring Capable

Note (1): These 1-byte register values are merely copied by the BBT3821 from the I²C address space on Power-up or RESET, or on a periodic or on-demand direct DOM update operation (i.e. with Register bit 1.C018'h.2 Table 51 not set) under the control of Register 1.A100'h (Table 38). The BBT3821 takes no action as a result of the values copied.

Table 36. XENPAK DOM ALARM FLAGS REGISTER

MDIO REGISTER, ADDRESS = 1.41072:3 (1.A070:1'h)					
BIT	NAME	SETTING	DEFAULT	R/W	DESCRIPTION ⁽¹⁾
1.41072.15:8	Reserved		00'h ⁽¹⁾	RO	
1.41072.7	TT_High	1 = Alarm Set 0 = Alarm Not Set	0'b	RO	Transceiver Temp High Alarm
1.41072.6	TT_Low		0'b	RO	Transceiver Temp Low Alarm
1.41072.5:4	Reserved		00'b		
1.41072.3	LBC_High	1 = Alarm Set 0 = Alarm Not Set	0'b	RO	Laser Bias Current High Alarm
1.41072.2	LBC_Low		0'b	RO	Laser Bias Current Low Alarm
1.41072.1	LOP_High		0'b	RO	Laser Output Power High Alarm
1.41072.0	LOP_Low		0'b	RO	Laser Output Power Low Alarm
1.41073.15:8	Reserved		00'h		
1.41073.7	ROP_High	1 = Alarm Set 0 = Alarm Not Set	0'b	RO	Receive Optical Power High Alarm
1.41073.6	ROP_Low		0'b	RO	Receive Optical Power Low Alarm
1.41073.5:0	Reserved		00'h		

Note (1): These 1-byte register values are copied by the BBT3821 from the I²C address space on Power-up or RESET, or on any DOM read operation. If the 'Indirect DOM Enable' bit (Register bit 1.C018'h.2 Table 51) is not set, a four-lane external DOM device is expected to determine the values for these registers, according to Section 11.3 in the XENPAK MSA Rev 3.0 specification. A single one-lane DOM device system will provide the values from the single DOM device here. If the 'Indirect DOM Enable' bit is set, the values from the "Representative" (as set by Register bits 1.C018'h.1:0 in Table 51) lane DOM are entered here. See "DOM Registers" on page 16. These bits are gated with the enable bits in 1.9006:7 (Table 30 & Table 31) and the LX4/CX4 select LX4_MODE pin to drive bits 1.9004.1 & 1.9003.1 (Table 28 & Table 27), and if enabled via 1.9002 & 1.9001 (Table 25 & Table 24) to drive the LASI pin.

Table 37. XENPAK DOM WARNING FLAGS REGISTER

MDIO REGISTER, ADDRESS = 1.41076:7 (1.A074:5'h)					
BIT	NAME	SETTING	DEFAULT	R/W	DESCRIPTION ⁽¹⁾
1.41076.15:8	Reserved		00'h ⁽¹⁾		
1.41076.7	TT_High	1 = Warning Set 0 = Warn. Not Set	0'b	RO	Transceiver Temp High Warning
1.41076.6	TT_Low		0'b	RO	Transceiver Temp Low Warning
1.41076.5:4	Reserved		00'b		

Table 37. XENPAK DOM WARNING FLAGS REGISTER (Continued)

MDIO REGISTER, ADDRESS = 1.41076:7 (1.A074:5'h)					
BIT	NAME	SETTING	DEFAULT	R/W	DESCRIPTION ⁽¹⁾
1.41076.3	LBC_High	1 = Warning Set 0 = Warning Not Set	0'b	RO	Laser Bias Current High Warning
1.41076.2	LBC_Low		0'b	RO	Laser Bias Current Low Warning
1.41076.1	LOP_High		0'b	RO	Laser Output Power High Warning
1.41076.0	LOP_Low		0'b	RO	Laser Output Power Low Warning
1.41077.15:8	Reserved		00'h		
1.41077.7	ROP_High	1 = Warning Set 0 = Warn. Not Set	0'b	RO	Receive Optical Power High Warning
1.41077.6	ROP_Low		0'b	RO	Receive Optical Power Low Warning
1.41077.5:0	Reserved		00'h		

Note (1): These 1-byte register values are merely copied by the BBT3821 from the I²C address space on Power-up or RESET, or on any DOM read operation. If the 'Indirect DOM Enable' bit (Register bit 1.C018'h.2 Table 51) is not set, a four-lane external DOM device is expected to determine the values for these registers, according Section 11.3 in the XENPAK MSA Rev 3.0 specification. A single one-lane DOM device system will provide the values from the single DOM device here. If the 'Indirect DOM Enable' bit is set, the values from the "Representative" (as defined by Register bits 1.C018'h.1:0 in Table 51), lane DOM are entered here.

Table 38. XENPAK DOM OPERATION CONTROL AND STATUS REGISTER

MDIO REGISTER, ADDRESS = 1.41216 (1.A100'h)					
BIT	NAME	SETTING	DEFAULT	R/W	DESCRIPTION
1.41216.15:4	Reserved		0000'h		
1.41216.3:2	DOM Command Status ⁽¹⁾	Current Status of DOM Command	00'b	RO	11 = Command failed 10 = Command in progress/Queued 01 = Command complete w success 00 = Idle
1.41216.1:0	DOM Command Type ⁽¹⁾	NVR operation to be performed	11'b ⁽²⁾	R/W	00 = Single DOM Read operation 01 = Periodic update, slowest rate ⁽³⁾ 10 = Periodic update, intermediate rate ⁽³⁾ 11 = Periodic update, fastest rate ⁽³⁾

Note (1): User writes to these bits are not valid unless the Command Status is Idle. The Command Status will not return to Idle until being read after command completion (either Succeed or Failed).

Note (2): At the end of a hardware RESETN or a register 1.0.15 RESET operation, if the XP_ENA pin is asserted, and the DOM control bits are set in 1.32890 (1.807A), the BBT3821 will automatically begin a 'Periodic update, fastest rate read' operation.

Note (3): The rates of the periodic reads are determined by bits 4:3 of register 1.49176 (1.C018'h), see Table 51.

VENDOR-SPECIFIC PMA/PMD AND GPIO REGISTERS (1.C001'H TO 1.C01D'H)

Table 39. PMA CONTROL 2 REGISTER

MDIO REGISTER, ADDRESS = 1.49153 (1.C001'h)					
BIT	NAME	SETTING	DEFAULT	R/W	DESCRIPTION
1.49153.15	PMA DC_O_DIS	1 = Disable, 0 = normal	0'b ⁽¹⁾	R/W	PMA DC Offset Disable
1.49153.14	Test	0 = normal	0'b ⁽²⁾ (1)	R/W	User must keep at 0.
1.49153.13	Amplitude adjust		1,0'h ⁽¹⁾ (3)	R/W	Optimizing Setting, TBD ⁽⁴⁾
1.49153.12:11	Reserved		0'h		
1.49153.10:8	PMA_LOS_TH	0'h = 160mV _{p-p} 1'h = 240mV _{p-p} 2'h = 200mV _{p-p} 3'h = 120mV _{p-p} 4'h = 80mV _{p-p} else = 160mV _{p-p}	LX4: ⁽³⁾ 0'h, CX4: 03'h ⁽¹⁾	R/W	Set the threshold voltage for the Loss Of Signal (LOS) detection circuit in PMA/PMD. Nominal levels are listed for each control value. Note that the differential peak-to-peak value is twice that listed.
1.49153.7:0	Reserved		00'h		

Note (1): These values may be overwritten by the Auto-Configure operation (See "Auto-Configuring Control Registers" on page 16 and Table 92 for details).

Note (2): Internal test purposes only.

Note (3): Default values depend on setting of LX4/CX4 select LX4_MODE pin. LX4 value is shown first.

Note (4): Optimum value to meet output templates. Contact BitBlitz for recommended value.

Table 40. PMA SERIAL LOOP BACK CONTROL REGISTER

MDIO REGISTER ADDRESS = 1.49156 (1.C004'h)					
BIT	NAME	SETTING	DEFAULT	R/W	DESCRIPTION
1.49156.15:13	Reserved				
1.49156.12	PMA Test LP	1 = enable 0 = disable	0'h ⁽¹⁾	R/W	Serial Network Test Loopback PMA Serial Loop Back Enable for each individual lane. When high, it routes the internal PMA Serial output to the PMA Serial input.
1.49156.11	PMA SLP_3		0'b ⁽²⁾	R/W	
1.49156.10	PMA SLP_2		0'b ⁽²⁾		
1.49156.9	PMA SLP_1		0'b ⁽²⁾		
1.49156.8	PMA SLP_0		0'b ⁽²⁾		
1.49156.7:0	Reserved				

Note (1): Loopback is from Serial I/P to Serial O/P. Recommended use for test purposes only; the lanes are swapped, and no pre-emphasis is performed.

Note (2): These values may be overwritten by the Auto-Configure operation (See "Auto-Configuring Control Registers" on page 16 and Table 92 for details).

Table 41. PMA PRE-EMPHASIS CONTROL

MDIO REGISTER ADDRESS = 1.49157 (1.C005'h)					
BIT	NAME	SETTING	DEFAULT ⁽¹⁾	R/W	DESCRIPTION
1.49157.15:12	PRE_EMP Lane 3	See Table 42 for settings	00'h/07'h	R/W	Configure the level of PMA pre-emphasis
1.49157.11:8	PRE_EMP Lane 2		00'h/07'h	R/W	
1.49157.7:4	PRE_EMP Lane 1		00'h/07'h	R/W	
1.49157.3:0	PRE_EMP Lane 0		00'h/07'h	R/W	

Note (1): Default values depend on setting of LX4/CX4 select LX4_MODE pin. LX4 value is shown first. The values may be overwritten by the Auto-Configure operation (See "Auto-Configuring Control Registers" on page 16 and Table 92 for details).

Table 42. PMA PRE-EMPHASIS CONTROL SETTINGS

(1)

ADDRESS 1.C005'h BITS 3:0	PRE-EMPHASIS (802.3ak) ⁽²⁾ = (1-V _{LOW} /V _{HI})	PRE-EMPHASIS VALUE = (V _{HI} / V _{LOW})-1	ADDRESS 1.C005'h BITS 3:0	PRE-EMPHASIS (802.3ak) ⁽²⁾ = (1-V _{LOW} /V _{HI})	PRE-EMPHASIS VALUE = (V _{HI} / V _{LOW})-1
0000	0%	0	1000	33.0%	0.493
0001	5.0%	0.053	1001	36.5%	0.575
0010	9.5%	0.105	1010	40.0%	0.667
0011	14.0%	0.163	1011	43.0%	0.754
0100	18.5%	0.227	1100	46.0%	0.852
0101	22.0%	0.282	1101	49.0%	0.961
0110	26.5%	0.361	1110	52.0%	1.083
0111 ⁽³⁾	30.0%	0.429	1111	54.5%	1.198

Note (1): See Figure 3 for illustration of the pre-emphasized waveform and meaning of symbols.

Note (2): This equation is the one used by the IEEE 802.3 CX4 Working Group when discussing pre-emphasis (alias Transmit equalization). The template normalization factor of 0.69 in step 6) of IEEE 802.3akD5.3 Section 54.6.3.6 reflects 0.31 (31%) pre-emphasis according to this equation.

Note (3): This is the Default value set on power-up or RESET if the LX4/CX4 LX4_MODE pin is set for CX4 operation. This setting allows for a small loss in the PCB traces and connectors before the IEEE 802.3akD5.3 defined TP2 compliance measurement point. The value may be overwritten by the Auto-Configure operation (See "Auto-Configuring Control Registers" on page 16 and Table 92 for details).

Table 43. PMA/PMD EQUALIZATION CONTROL

MDIO REGISTER ADDRESS = 1.49158 (1.C006'h)					
BIT	NAME	SETTING	DEFAULT ⁽¹⁾	R/W	DESCRIPTION
1.49158.15:14	Reserved				
1.49158.3:0	PMA_EQ_COEFF	0'h = no boost in equalizer. F'h = boost is maximum	0'h/C'h	R/W	Configuration of the PMA/PMD equalizer

Note (1): Default values depend on setting of LX4/CX4 select LX4_MODE pin. LX4 value is shown first. The value may be overwritten by the Auto-Configure operation (See "Auto-Configuring Control Registers" on page 16 and Table 92 for details).

Table 44. PMA SIG_DET AND LOS DETECTOR STATUS REGISTER

MDIO REGISTER ADDRESS = 1.49162 (1.C00A'h)					
BIT	NAME	SETTING	DEFAULT	R/W	DESCRIPTION
1.49162.15:8	Reserved		00'b		
1.49162.7	SIG_DET_3	1 = CX4 Signal Detect Asserted 0 = CX4 Signal Detect Deasserted	1'b	RO/LL ⁽¹⁾	Signal Detect for PMA lane 3
1.49162.6	SIG_DET_2		1'b		Signal Detect for PMA lane 2
1.49162.5	SIG_DET_1		1'b		Signal Detect for PMA lane 1
1.49162.4	SIG_DET_0		1'b		Signal Detect for PMA lane 0
1.49162.3	PMA_LOS_3	1 = Signal less than threshold 0 = Signal greater than threshold	0'b	RO/LH ⁽²⁾	Loss Of Signal for PMA lane 3
1.49162.2	PMA_LOS_2		0'b		Loss Of Signal for PMA lane 2
1.49162.1	PMA_LOS_1		0'b		Loss Of Signal for PMA lane 1
1.49162.0	PMA_LOS_0		0'b		Loss Of Signal for PMA lane 0

Note (1): These bits are latched low on any SIG_DET failure condition detected. They are reset high on being read.

Note (2): These bits are latched high on any LOS condition detected. They are reset low on being read.

Table 45. PMA/PMD MISCELLANEOUS ADJUSTMENT REGISTER

MDIO REGISTER ADDRESS = 1.49163 (1.C00B'h)					
BIT	NAME	SETTING	DEFAULT	R/W	DESCRIPTION
1.49163.15:10	Reserved		00'h		
1.49163.9:6	Amplitude	Output Control ⁽¹⁾	LX4: 5'h CX4: 3'h	R/W	
1.49163.5:2	Pre-emphasis	Fine Control per lane ⁽¹⁾	LX4: 0'h CX4: F'h	R/W	Bit 5 is for Lane 3, etc.
1.49163.1:0	Reserved	Internal	00'b	R/W	Test Function, do not alter.

Note (1): Default values depend on setting of LX4/CX4 select LX4_MODE pin. LX4 value is shown first. The value may be overwritten by the Auto-Configure operation (See "Auto-Configuring Control Registers" on page 16 and Table 92 for details).

Table 46. PMA/PMD/PCS/PHY XS SOFT RESET REGISTER

MDIO REGISTER ADDRESS = [1,3:4].49167 ([1,3:4].C00F'h)					
BIT	NAME	SETTING	DEFAULT	R/W	DESCRIPTION
1.49167.15 [3,4].49167.15	SOFT_RESET	Write 1 to initiate.	0'b	R/W SC	Reset the entire chip except MDIO register settings ⁽¹⁾
[1,3:4].49167.14:0	Reserved				

Note (1): This reset will NOT cause a reload of the NVR or DOM areas, nor an Auto-Configure operation. It will reset the Byte Sync engine, the Lane Alignment engine, the FIFO pointers, and the I²C controller. The BBT3821 will (if "normally" configured) transmit ||LF|| local fault signals until Byte Sync and Lane Alignment are re-established, and any DOM update in progress may be aborted.

Table 47. GPIO PIN DIRECTION CONFIGURE REGISTER

MDIO REGISTER ADDRESS = 1.49168 (1.C010'h)					
BIT	NAME	SETTING	DEFAULT	R/W	DESCRIPTION
1.49168.15:5	Reserved				
1.49168.4:0	GPIO pins configuration	1 = output 0 = input	00'h ⁽¹⁾	R/W	Controls whether GPIO pin is used as input or output

Note (1): The value may be overwritten by the Auto-Configure operation (See "Auto-Configuring Control Registers" on page 16 and Table 92 for details).

Table 48. GPIO PIN INPUT STATUS REGISTER

MDIO REGISTER ADDRESS = 1.49169 (1.C011'h)					
BIT	NAME	SETTING	R/W	DESCRIPTION	
1.49169.15:13	Reserved				
1.49169.12:8	LASI I/P value	1 = can trigger LASI ⁽¹⁾ 0 = cannot trigger LASI	RO/LH	XOR of GPIO Pin I/P and Invert register 1.49170.13:8.	
1.49169.7:5	Reserved				
1.49169.4:0	GPIO Pin I/P Value	1 = Pin Hi 0 = Pin Lo	RO	Original values from GPIO pins directly.	

Note (1): If any of these bits is set to '1', it triggers LASI if the corresponding bit in 1.49170.5:0 and the GPIO enable bit 1.36866.3 are set high.

Table 49. TX_FAULT & GPIO PIN TO LASI CONFIGURE REGISTER

MDIO REGISTER ADDRESS = 1.49170 (1.C012'h)					
BIT	NAME	SETTING	DEFAULT	R/W	DESCRIPTION
1.49170.15:14	Reserved				
1.49170.13	Invert TX_FAULT	1 = Pin Low, 0 = Pin High to trigger LASI	0'b ⁽²⁾	R/W	Control Polarity of TX_FAULT pin which will trigger LASI (if enabled)
1.49170.12:8	Invert LASI I/P	1 = Invert to LASI 0 = Straight to LASI	00'h ⁽²⁾	R/W	Control XOR of GPIO Pin I/P to LASI I/P register 1.49169.13:8.
1.49170.7:5	Reserved				
1.49170.4:0	Enable LASI I/P	1 = Enable ⁽¹⁾ 0 = Do not Enable	00'h ⁽²⁾	R/W	Enable the GPIO pin value to trigger GPIO_ALARM to LASI

Note (1): If any of these bits is set to '1', it triggers LASI if the corresponding bit in 1.49169.12:8 and the GPIO enable bit 1.36866.3 are set high. The polarity that will trigger LASI is set by bits 1.49170.12:8 above.

Note (2): These values may be overwritten by the Auto-Configure operation (See "Auto-Configuring Control Registers" on page 16 and Table 92 for details).

Table 50. GPIO PIN OUTPUT REGISTER

MDIO REGISTER ADDRESS = 1.49171 (1.C013'h)					
BIT	NAME	SETTING	DEFAULT	R/W	DESCRIPTION
1.49171.15:5	Reserved				
1.49171.4:0	GPIO Pin Output	0 = Low 1 = High	00'h ⁽¹⁾	R/W	Controls GPIO pin level if set as output

Note (1): The value may be overwritten by the Auto-Configure operation (See "Auto-Configuring Control Registers" on page 16 and Table 92 for details).

Table 51. DOM CONTROL REGISTER

MDIO REGISTER ADDRESS = 1.49176 (1.C018'h)					
BIT	NAME	SETTING	DEFAULT ⁽¹⁾	R/W	DESCRIPTION
1.49176.15:6	Reserved				
1.49176.5	Test Control		0'b	R/W	User must keep at 0.
1.49176.4:3	DOM Update period	See Table 52	00'h	R/W	Controls rates at which DOM A/D values are updated
1.49176.2	Indirect DOM Enable	1 = Enable 0 = Disable	0'b ⁽²⁾	R/W	Enable updates from four DOM devices. See Table 33, Table 38
1.49176.1:0	Representative	Lane value	00'b ⁽²⁾	R/W	Select Lane for 1.A060:D'h

Note (1): The values may be overwritten by the Auto-Configure operation (See "Auto-Configuring Control Registers" on page 16 and Table 92 for details).

Note (2): If 'Indirect DOM Enable' is set, then the DOM A/D and Flag values are loaded from the I²C spaces pointed to by the Indirect Mode values in Table 53 and Table 54, and 'Representative' controls which lane's A/D values will appear in 1.A060:D'h. If not, then 'Representative' has no effect, and the full DOM area is updated from a single DOM device. See "DOM Registers" on page 16 for details.

Table 52. DOM PERIODIC UPDATE WAITING TIME VALUES

(Approximate, based on REF_CLOCK = 156.25 MHz; default underlined)

1.41216.1:0 (1.A100'h:1:0) BITS ⁽¹⁾	1.49176.4:3 (1.C018'h) BITS ⁽¹⁾			
	<u>00</u> ⁽²⁾	01	10	11
00	N/A	N/A	N/A	N/A
01	800ms	1000ms	1300ms	1600ms
10	400ms	500ms	600ms	700ms
<u>11</u> ⁽²⁾	<u>100ms</u> ⁽²⁾	150ms	200ms	300ms

Note (1): See Table 38 and Table 51 for these registers.

Note (2): These are the Default values. The value in 1.C018'h may be overwritten by the Auto-Configure operation

Table 53. DOM INDIRECT MODE START ADDRESS REGISTERS

MDIO REGISTER ADDRESSES = 1.49177:8 (1.C019:1A'h)					
BIT	NAME	SETTING	DEFAULT ⁽¹⁾	R/W	DESCRIPTION
1.49177.15:8	Lane 3 DOM	Start Address	60'h	R/W	Start address to read A/D values from DOM monitor device of respective lane
1.49177.7:0	Lane 2 DOM	Start Address	60'h	R/W	
1.49178.15:8	Lane 1 DOM	Start Address	60'h	R/W	
1.49178.7:0	Lane 0 DOM	Start Address	60'h	R/W	

Note (1): The values may be overwritten by the Auto-Configure operation (See "Auto-Configuring Control Registers" on page 16 and Table 92 for details).

Table 54. DOM INDIRECT MODE DEVICE ADDRESS REGISTERS

MDIO REGISTER ADDRESSES = 1.49179:80 (1.C01B:1C'h)					
BIT	NAME	SETTING	DEFAULT ⁽¹⁾	R/W	DESCRIPTION
1.49179.15:9	Lane 3 DOM	Device Address	54'h	R/W	Note: I ² C Device address to read A/D values from DOM monitor device of respective lane is twice set value. Thus 'Default' column addresses are A8'h, A6'h A4'h and A2'h for Lanes 3, 2, 1 & 0 respectively. LSB reflects 'Read' operation value
1.49179.8	Not used, Set by current operation				
1.49179.7:1	Lane 2 DOM	Device Address	53'h	R/W	
1.49179.0	Not used, Set by current operation				
1.49180.15:8	Lane 1 DOM	Device Address	52'h	R/W	
1.49180.7	Not used, Set by current operation				
1.49180.7:1	Lane 0 DOM	Device Address	51'h	R/W	
1.49180.0	Not used, Set by current operation				

Note (1): The values may be overwritten by the Auto-Configure operation (See "Auto-Configuring Control Registers" on page 16 and Table 92 for details).

Table 55. OPTICAL STATUS & CONTROL PIN POLARITY REGISTER

MDIO REGISTER ADDRESS = 1.49181 (1.C01D'h)					
BIT	NAME	SETTING	DEFAULT ⁽¹⁾	R/W	DESCRIPTION
1.49181.15:7	Reserved				
1.49181.6	OPRLOS[3:0]	1 = low -> LOS 0 = high -> LOS	0'b	R/W	Input polarity to 1.10 and enable Byte Synchron in LX4 mode
1.49181.5	TX_ENA[3:0]	1 = Active Low 0 = Active Hi	0'b	R/W	Polarity of TX_ENA outputs
1.49181.4	TX_ENC		0'b	R/W	Polarity of TX_ENC input
1.49181.3	OPRXOP	1 = Pin Low to trigger LASI 0 = Pin High to trigger LASI	0'b	R/W	Control Polarity of respective input pins which will trigger LASI (if enabled)
1.49181.2	OPTTEMP		0'b	R/W	
1.49181.1	OPTXLBC		0'b	R/W	
1.49181.0	OPTXLOP		0'b	R/W	

Note (1): The values may be overwritten by the Auto-Configure operation (See "Auto-Configuring Control Registers" on page 16 and Table 92 for details).

Table 56. MDIO PCS DEVAD 3 REGISTERS

PCS DEVICE 3 MDIO REGISTERS							
ADDRESS		NAME	DESCRIPTION	DEFAULT	AC ⁽²⁾	R/W	DETAILS
DEC	HEX						
3.0	3.0	PCS Control 1	Reset, Enable loop back mode.	2040'h		R/W	Table 57
3.1	3.1	PCS Status 1	PCS Fault, Link Status	0004'h ⁽³⁾		RO LL	Table 58
3.2:3	3.2:3	ID Code	Manufacturer and Device OUI	01839C6V'h		RO	See ⁽¹⁾
3.4	3.4	Speed Ability	10Gbps Ability	0001'h		RO	Table 7
3.5	3.5	IEEE Devices	Devices in Package, Clause 22 capable	001A'h		RO	Table 8
3.6	3.6	Vendor Devices	Vendor Specific Devices in Pkg	0000'h		RO	Table 8
3.7	3.7	PCS Type	IEEE PCS TYPE SELECT REGISTER	0001'h		RO	Table 59
3.8	3.8	PCS Status 2	Device Present, Local Fault, Type Summary	8002'h ⁽³⁾		RO	Table 60
3.14:15	3.E:F	Package ID	Package OUI, etc.	00000000'h		RO	See ⁽⁴⁾
3.24	3.18	PCS-X Status 3	IEEE 10GBASE-X PCS STATUS REGISTER	See ⁽⁵⁾		RO	Table 61
3.25	3.19	PCS Test	IEEE 10GBASE-X PCS TEST CONTROL REGISTER	0000'h		R/W	Table 62
3.49152	3.C000	PCS Control 2	PCS CONTROL REGISTER 2	0F6F'h	A	R/W	Table 63
3.49153	3.C001	PCS Control 3	PCS Control Register 3	0801'h	A	R/W	Table 64
3.49154	3.C002	PCS ERROR	PCS INTERNAL ERROR CODE REGISTER	00FE'h	A	R/W	Table 66
3.49155	3.C003	PCS IDLE	PCS INTERNAL IDLE CODE REGISTER	0007'h	A	R/W	Table 67
3.49156	3.C004	PCS // Loop Back	PCS PARALLEL NETWORK LOOP BACK CONTROL REGISTER	0000'h	A	R/W	Table 68
3.49159	3.C007	Test_Flags	Receive Path Test & Status Flags	0000'h		RO LH	Table 69
3.49160	3.C008	Output Ctrl	Output Control and Test function	AAAA'h		R/W	Table 70
3.49161	3.C009	Half Rate	Half rate clock mode enable	0000'h		R/W	Table 71
3.49164	3.C00C	BIST Ctrl	BIST Control Register	0000'h		R/W	Table 72
3.49165 3.49166	3.C00D 3.C00E	BIST Error	BIST ERROR Counter Registers	0000'h		RO/ RCNR	Table 73
3.49167	3.C00F	Soft Reset	Reset (non MDIO)	0000'h		R/W SC	Table 46

Note (1): 'V' is a version number. See "JTAG & AC-JTAG Operations" on page 53 for a note about the version number.

Note (2): For rows with "A", the default value may be overwritten by the Auto-Configure operation (See "Auto-Configuring Control Registers" on page 16 and Table 92 for details).

Note (3): Read value depends on status signal values. Value shown indicates 'normal' operation.

Note (4): The IEEE 802.3ae specification allows this to be all zeroes. A XENPAK (etc.) host can more readily determine where the NVR registers are if this value is zero.

Note (5): If IEEE 802.3ae (and default) setting for PCS Loopback, 180F'h. If PCS Loopback allowed, 1C0F'h. See Table 61 and Table 64.

IEEE PCS REGISTERS (3.0 TO 3.25/3.0019'H)

Table 57. IEEE PCS CONTROL 1 REGISTER

MDIO REGISTER ADDRESS = 3.0 (3.0000'h)					
BIT(S)	NAME	SETTING	DEFAULT	R/W	DESCRIPTION
3.0.15 1.0.15 4.0.15	Reset	1 = reset 0 = reset done, normal operation	0'b	R/W SC	Writing 1 to this bit will reset the whole chip, including the MDIO registers.
3.0.14 ⁽¹⁾	PCS_LB_EN	Optionally, enable PCS Loopback, otherwise reserved	0'b	R/W	If enabled by EN_PCS_LB (see bit 3.C001'h.7, Table 64) perform PCS Loopback, and is a R/W bit; otherwise, effectively a reserved RO 0'b bit ⁽¹⁾ .
3.0.13	Speed Select	1 = 10Gbps	1'b	RO	1 = bits 5:2 select speed
3.0.12	Reserved		00'h		
3.0.11	LOPOWER	0 = Normal Power	0'b	R/W	No Low Power Mode, writes ignored
3.0.10:7	Reserved				
3.0.6	Speed Select	1 = 10Gbps	1'b	RO	1 = bits 5:2 select speed
3.0.5:2	Speed Select	0000 = 10Gbps	0'h	RO	Operates at 10Gbps
3.0.1:0	Reserved		0'b		

Note (1): This bit is not permitted to be a PCS loopback bit by IEEE 802.3ae-2002 subclause 45.2.3.1.2 in 10GBASE-X PCS devices. Intersil has submitted a maintenance request (#1113) to allow that use of this bit. Many XENPAK hosts, however, expect this loopback (which is mandatory for 10GBASE-R PCS devices). Setting the 3.C001'h.7 bit, (Table 64) will activate this loopback enable bit, but cause the BBT3821 to be non-conforming to the current 802.3 specification. See "Loopback Modes" on page 13).

Table 58. IEEE PCS STATUS 1 REGISTER

MDIO REGISTER ADDRESS = 3.1 (3.0001'h)					
BIT	NAME	SETTING	DEFAULT	R/W	DESCRIPTION
3.1.15:8	Reserved		00'h		
3.1.7	Local Fault	1 = PCS Local Fault	0	RO	Derived from Register 3.0008'h
3.1.6:3	Reserved		0'h		
3.1.2	Rx Link Up	1 = PCS Rx Link Up 0 = PCS Rx Link Down	1 ⁽¹⁾	RO LL ⁽¹⁾	'Up' means CX4/LX4 signal level is OK, Byte Synch and Lane-Lane Alignment have all occurred
3.1.1	LoPwrAble	Low Power Ability	0	RO	Device does not support a low power mode
3.1.0	Reserved		0		

Note (1): This bit is latched low on a detected Fault condition. It is set high on being read.

Table 59. IEEE PCS TYPE SELECT REGISTER

MDIO REGISTER ADDRESS = 3.7 (3.0007'h)					
BIT	NAME	SETTING	DEFAULT	R/W	DESCRIPTION
3.7.15:2	Reserved		000'h		
3.7.1:0	PCS Type	01 = 10GBASE-X	01b	RO ⁽¹⁾	Writes ignored

Note (1): Although the 802.3ae specification describes this register as type R/W, this register cannot have any value other than that reflecting the 10GBASE-X PCS. Thus writing any other value is ignored, and the register is in effect type RO.

Table 60. IEEE PCS STATUS 2 DEVICE PRESENT & FAULT SUMMARY REGISTER

MDIO REGISTER ADDRESS = 3.8 (3.0008'h)					
BIT	NAME	SETTING	DEFAULT	R/W	DESCRIPTION
3.8.15:14	Device present	10 = Device present	10'b	RO	When read as "10", it indicates that a device is present at this device address
3.8.13:12	Reserved				
3.8.11	TX LocalFit	1 = TX Local Fault; on Egress channel	0'b	RO LH ⁽¹⁾	PLL Lock Failure is only PCS TX Fault
3.8.10	RX LocalFit	1 = RX Local Fault; on Ingress channel	0'b	RO LH ⁽¹⁾	Lane Alignment or Byte Alignment not done, or Loss of Signal, from Register 3.24 (3.0018'h)
3.8.9:3	Reserved				
3.8.2	10GBASE-W	0 = cannot perform	0'b	RO	Device cannot be 10GBASE-W
3.8.1	10GBASE-X	1 = can perform	1'b	RO	Device can perform 10GBASE-X
3.8.0	10GBASE-R	0 = cannot perform	0'b	RO	Device cannot be 10GBASE-R

Note (1): These bits are latched high on any Fault condition detected. They are reset low (cleared) on being read. They will also be reset low on reading the LASI registers 1.9003'h (bit 10, see Table 27) or 1.9004'h (bit 11, see Table 28)

Table 61. IEEE 10GBASE-X PCS STATUS REGISTER

MDIO REGISTER ADDRESSES = 3.24 (3.0018'h)					
BIT	NAME	SETTING	DEFAULT	R/W	DESCRIPTION
3.24.15:13	Reserved				
3.24.12	Lane_Align	1 = 4 Lanes Aligned 0 = Lanes not aligned	1'b ⁽¹⁾	RO	1 = All four 3G receive lanes (on ingress path) are aligned
3.24.11	Test_Pattern	Test Pattern Abilities	1'b	RO	1 = The device is able to generate test patterns for 10GBASE-X
3.24.10	PCS Loopback Ability ⁽²⁾ or Reserved	1 = has Optional PCS Loopback Ability.	0'b	RO	If enabled by EN_PCS_LB (see bit 3.C001'h.7, Table 64) indicates PCS Loopback ability, and is a 1'b bit; otherwise, a reserved 0'b bit ⁽²⁾ .
3.24.9:4	Reserved		00'h		
3.24.3	Lane3 Sync	1 = PCS Lane is Synchronized 0 = PCS Lane not Synchronized	1'b ⁽¹⁾	RO	Reflects the PCS_SYNC byte alignment state machine condition; not valid if not enabled in device (see Table 63)
3.24.2	Lane2 Sync		1'b ⁽¹⁾	RO	
3.24.1	Lane1 Sync		1'b ⁽¹⁾	RO	
3.24.0	Lane0 Sync		1'b ⁽¹⁾	RO	

Note (1): The status of these bits depends on the signal conditions. Default shown is for normal operation. The bits contribute to the RX Local Fault bit, see Table 60.

Note (2): See Note (1) to Table 57, Note (2) to Table 64 and/or "PCS (Parallel) Loopback (4.C004.[3:0] & Optionally 3.0.14)" under "Loopback Modes" on page 13. If enabled, this register bit does NOT conform to the IEEE 802.3ae-2002 specification.

Table 62. IEEE 10GBASE-X PCS TEST CONTROL REGISTER

MDIO REGISTER ADDRESS = 3.25 (3.0019'h)					
BIT	NAME	SETTING	DEFAULT	R/W	DESCRIPTION
3.25.15:3	Reserved				
3.25.2	PCS TestPatEn	Transmit Test Pattern Enable	0'b	R/W	0 = Do not Transmit test pattern 1 = Transmit test pattern
3.25.1:0	PCS TestPat Type	Test pattern select	00'b	R/W	11 = Reserved 10 = Mixed frequency test pattern (Continuous /K/ = K28.5) 01 = Low frequency test pattern (repeat 0000011111 = K28.7) 00 = High frequency test pattern (repeat 0101010101 = D10.2)

Note (1): For other test pattern generation capabilities incorporated in the BBT3821, including CJPAT and CRPAT, see Table 72.

VENDOR-SPECIFIC PCS REGISTERS (3.C000'H TO 3.C00E'H)

Table 63. PCS CONTROL REGISTER 2

MDIO REGISTER ADDRESS = 3.49152 (3.C000'h)					
BIT	NAME	SETTING	DEFAULT ⁽¹⁾	R/W	DESCRIPTION
3.49152.15:14	Test Mode	00'b	00'b	R/W	User should leave at 00'b
3.49152.13:12	Reserved				
3.49152.11	PCS Clock PSYNC		1'b	R/W	1 = Synchronize/align four lanes 0 = Do not synchronize/align four lanes
3.49152.10	PCS CODECENA	0 = disable 1 = enable	1'b	R/W	Internal 8B/10B PCS Codec enable/disable
3.49152.9:8	PCS CDET[1:0]	Comma Detect Select	11'b	R/W	These bits individually enable positive and negative disparity "comma" detection. 11 = Enable both positive and negative comma detection 10 = Enable positive comma detection only 01 = Enable negative comma detection only 00 = Disable comma detection
3.49152.7	PCS DSKW_SM_EN	0 = disable ⁽²⁾ 1 = enable	0'b	R/W	Enable De-skew state machine control ⁽³⁾ . Forced enabled by XAUI_EN. May not operate correctly unless the PCS_SYNC_EN bit is also set.
3.49152.6:5	PCS RCLKMODE ⁽⁴⁾	11'b = Local Reference Clock	11'b	R/W	Other values should only be used if incoming data is frequency-synchronous with the local reference clock ⁽⁴⁾
3.49152.4	PCS_SYNC_EN	0 = disable ⁽²⁾ 1 = enable	0'b	R/W	Enable 8b/10b PCS coding synchronized state machine ⁽³⁾ to control the byte alignment (IEEE 'code-group alignment') of the high speed de-serializer
3.49152.3	PCS IDLE_D_EN	1 = enabled 0 = disabled	1'b	R/W	Enables IDLE vs. NON-IDLE detection for lane-lane alignment. Overridden by XAUI_EN, see Table 64
3.49152.2	PCS ELST_EN	1 = enabled 0 = disabled	1'b	R/W	Enable the elastic function of the receiver buffer
3.49152.1	PCS A_ALIGN_DIS	1 = disabled ⁽¹⁾ 0 = enabled	1'b	R/W	Receiver aligns data on incoming "/A/" characters (K28.3). If disabled (default), receiver aligns data on IDLE to non-IDLE transitions (if bit 3 set). Overridden by XAUI_EN, see Table 64
3.49152.0	PCS CAL_EN	1 = enabled 0 = disabled	1'b	R/W	Enable de-skew calculator of receiver Align FIFO

Note (1): The default values may be overwritten by the Auto-Configure operation (See "Auto-Configuring Control Registers" on page 16 and Table 92 for details).

Note (2): These bits are overridden by PCS XAUI_EN, see Table 64 and Table 65.

Note (3): These state machines are implemented according to 802.3ae-2002 clause 48.6.2.

Note (4): If the RCLKMODE bits are set to 10'b, the internal XGMII clock from the PCS to the PHY XS is set to the recovered clock. If the PCS Clock PSYNC bit is set (the default), the recovered clock from Lane 0 is used for all four lanes, if cleared, or if the RCLKMODE bits are set to 01'b or 00'b, each lane uses its own recovered clock. If the incoming data is NOT frequency-synchronous with the local reference clock, data will be corrupted (occasional characters will be lost, or repeated).

Table 64. PCS CONTROL REGISTER 3

MDIO REGISTER ADDRESS = 3.49153 (3.C001'h)					
BIT	NAME	SETTING	DEFAULT	R/W	DESCRIPTION
3.49153.15:12	Reserved				
3.49153.11	PCS XAUI_EN	1 = enable 0 = disable	1'b ⁽¹⁾	R/W	Enables all XAUI features per 802.3ae-2002. It is equivalent to setting the configuration bits listed in Table 65 (but does not change the actual value of the corresponding MDIO registers' bits).
3.49153.10:8	Reserved				
3.49153.7	EN_PCSLB_EN		0'b ⁽¹⁾		Enable 3.0.14 Loopback Control ⁽²⁾

Table 64. PCS CONTROL REGISTER 3 (Continued)

MDIO REGISTER ADDRESS = 3.49153 (3.C001'h)					
BIT	NAME	SETTING	DEFAULT	R/W	DESCRIPTION
3.49153.6	PCS AKR_SM_EN	1 = enable random A/K/R 0 = /K/ only ⁽³⁾	0'b ⁽¹⁾	R/W	Enable pseudo- random A/K/R ⁽⁴⁾ in Inter Packet Gap (IPG) on PCS transmitter side (vs. /K/ only)
3.49153.5	PCS TRANS_EN	1 = enable 0 = disable ⁽³⁾ Overridden by XAUI_EN, see Table 65	0'b ⁽¹⁾	R/W	This bit enables the transceiver to translate an "IDLE" pattern in the internal FIFOs (matching the value of register 3.C003'h) to and from the XAUI IDLE /K/ comma character or /A/, /K/ & /R/ characters.
3.49153.4	Reserved				
3.49153.3	TX_SDR	PCS receive data rate	0'b ⁽¹⁾	R/W	1 = PCS egress takes data from PHY XS at half speed 0 = PCS egress takes data from PHY XS at full speed
3.49153.2:0	Reserved		001'b		

Note (1): These values may be overwritten by the Auto-Configure operation (See "Auto-Configuring Control Registers" on page 16 and Table 92 for details).

Note (2): PCS loopback via bit 3.0.14 (Table 57) is NOT permitted by IEEE 802.3ae-2002 for 10GBASE-X PCS devices. Many XENPAK hosts, however, expect this loopback (which is mandatory for 10GBASE-R PCS devices). Setting this bit will enable this loopback, but cause the BBT3821 to be non-conforming to the current 802.3 specification. See "Loopback Modes" on page 13).

Note (3): These bits are overridden by PCS XAUI_EN, see also Table 65.

Note (4): This state machine is implemented according to IEEE 802.3ae-2002 clause 48.2.6.

Table 65. PCS or PHY XS XAUI_EN CONTROL OVERRIDE FUNCTIONS

BITS OVERRIDDEN BY XAUI_EN Bit, D.49153.11 (D.C001'h.11) = 1'b ⁽¹⁾					
REG. BIT ⁽¹⁾	NAME	OVERRIDE TO	DEFAULT	R/W	DESCRIPTION
D.49153.5	TRANS_EN	1 = enable	0'b	R/W	Translates /A/K/R/ to-from //
D.49153.6	AKR_SM_EN	1 = enable	0'b	R/W	Generate pseudo-random /A/K/R/
D.49152.1	A_ALIGN_DIS	0 = enabled	1'b	R/W	Aligns data on incoming " A "
D.49152.4	PCS_SYNC_EN	1 = enable	0'b	R/W	IEEE Clause 48.2.6 State Machine
D.49152.7	DSKW_SM_EN	1 = enable	0'b	R/W	IEEE Clause 48.2.6 State Machine
D.49154	ERROR Code	FE'h	FE'h	R/W	Internal FIFO ERROR character

Note (1): "D" is either 3 for PCS or 4 for PHY XS. Behavior of the two devices is entirely independent of each other.

Table 66. PCS INTERNAL ERROR CODE REGISTER

MDIO REGISTER, ADDRESS = 3.49154 (3.C002'h)					
BIT	NAME	SETTING	DEFAULT ⁽¹⁾	R/W	DESCRIPTION
3.49154.15:8	Reserved				
3.49154.7:0	PCS ERROR	Desired Value ⁽²⁾	FE'h	R/W	Error Code. These bits allow the internal FIFO ERROR control character to be programmed.

Note (1): The value may be overwritten by the Auto-Configure operation (See "Auto-Configuring Control Registers" on page 16 and Table 92 for details).

Note (2): These bits are overridden to FE'h by XAUI_EN, see Table 64 and Table 65.

Table 67. PCS INTERNAL IDLE CODE REGISTER

MDIO REGISTER ADDRESS = 3.49155 (3.C003'h)					
BIT	NAME	SETTING	DEFAULT ⁽¹⁾	R/W	DESCRIPTION
3.49155.15:8	Reserved				
3.49155.7:0	PCS XG_IDLE	Desired Value	07'h	R/W	IDLE pattern in internal FIFOs for translation to/from XAUI IDLEs

Note (1): The value may be overwritten by the Auto-Configure operation (See "Auto-Configuring Control Registers" on page 16 and Table 92 for details).

Table 68. PCS PARALLEL NETWORK LOOP BACK CONTROL REGISTER

MDIO REGISTER ADDRESS = 3.49156 (3.C004'h)					
BIT	NAME	SETTING	DEFAULT	R/W	DESCRIPTION
3.49156.15:4	Reserved				
3.49156.3	PLP_3	1 = enable PCS Parallel Network loopback ⁽²⁾ 0 = disable	0'b ⁽¹⁾	R/W	PCS Parallel Network Loop Back Enable for each individual lane. When high, routes the CX4/LX4 Serial input to the CX4/LX4 Serial output via the XGMII side of the PCS.
3.49156.2	PLP_2		0'b ⁽¹⁾		
3.49156.1	PLP_1		0'b ⁽¹⁾		
3.49156.0	PLP_0		0'b ⁽¹⁾		

Note (1): The default value may be overwritten by the Auto-Configure operation (See "Auto-Configuring Control Registers" on page 16 and Table 92 for details).

Note (2): Equivalent to a loopback at the XGMII input side of the PHY XS.

Table 69. PCS RECEIVE PATH TEST AND STATUS FLAGS

MDIO REGISTER ADDRESS = 3.49159 (3.C007'h)					
BIT	NAME	SETTING	DEFAULT	R/W	DESCRIPTION
3.49159.15:12	Test Flags		0'h	ROLH	Special test use only
3.49159.11	EFIFO_3	1 = EFIFO error in Lane 0 = no EFIFO error in Lane	0'b		PCS Elasticity FIFO Overflow/Underflow Error Detection ⁽¹⁾
3.49159.10	EFIFO_2		0'b	ROLH	
3.49159.9	EFIFO_1		0'b	ROLH	
3.49159.8	EFIFO_0		0'b	ROLH	
3.49159.7	Code_3	1 = 10b/8b Code error in Lane 0 = no 10b/8b Code error	0'b	ROLH	PCS 10b/8b Decoder Code Violation Detection ⁽¹⁾
3.49159.6	Code_2		0'b	ROLH	
3.49159.5	Code_1		0'b	ROLH	
3.49159.4	Code_0		0'b	ROLH	
3.49159.3:0	Test Flags		0'h	ROLH	Special test use only

Note (1): Note (1): These bits are latched high on any Fault condition detected. They are reset low (cleared) on being read. They will also be reset low on reading the LASI register 1.9003'h (see Table 27)

Table 70. PMA/PCS OUTPUT CONTROL & TEST FUNCTION REGISTER

MDIO REGISTER ADDRESS = 3.49160 (3.C008'h)					
BIT	NAME	SETTING	DEFAULT	R/W	DESCRIPTION
3.49160.15:14	Reserved		10'b	R/W	Test Function, do not alter
3.49160.13	ENA_3	Enable Lane 3 O/P	1'b	R/W	0 = disable (indep. of LX4_MODE)
3.49160.12:10	Reserved		010'b	R/W	Test Function, do not alter
3.49160.9	ENA_2	Enable Lane 2 O/P	1'b	R/W	0 = disable (indep. of LX4_MODE)
3.49160.8:6	Reserved		010'b	R/W	Test Function, do not alter
3.49160.5	ENA_1	Enable Lane 1 O/P	1'b	R/W	0 = disable (indep. of LX4_MODE)
3.49160.12:10	Reserved		010'b	R/W	Test Function, do not alter
3.49160.1	ENA_0	Enable Lane 0 O/P	1'b	R/W	0 = disable (indep. of LX4_MODE)
3.49160.0	Reserved		0'b	R/W	Test Function, do not alter

Table 71. PCS/PHY XS HALF RATE CLOCK CONTROL REGISTER

MDIO REGISTER ADDRESSES = 3.49161 & 4.49161 ([3,4].C009'h)					
BIT	NAME	SETTING	DEFAULT	R/W	DESCRIPTION
3.49161.15:4 4.49161.15:4	Reserved		0'h	R/W	
3.49161.3 4.49161.3	HALF_RATE 3	1'b = half rate clock 0'b = full rate clock	0'b	R/W	Lane 3 is running at half rate clock speed
3.49161.2 4.49161.2	HALF_RATE 2	1'b = half rate clock 0'b = full rate clock	0'b	R/W	Lane 2 is running at half rate clock speed
3.49161.1 4.49161.1	HALF_RATE 1	1'b = half rate clock 0'b = full rate clock	0'b	R/W	Lane 1 is running at half rate clock speed
3.49161.0 4.49161.0	HALF_RATE 0	1'b = half rate clock 0'b = full rate clock	0'b	R/W	Lane 0 is running at half rate clock speed

Table 72. BIST CONTROL REGISTER

MDIO REGISTER ADDRESS = 3.49164 (3.C00C'h)					
BIT	NAME	SETTING	DEFAULT	R/W	DESCRIPTION ⁽¹⁾
3.49164.15	BIST_EN	BIST generator enable	0'b	R/W	1 = Enable BIST generator 0 = Disable BIST generator
3.49164.14:12	Reserved				
3.49164.11	BIST_DIR	Select BIST data output direction	0'b	R/W	1 = BIST to PCS (transmit path) 0 = BIST to XGXS (receive path)
3.49164.10:8	BIST_PAT	Select BIST generator data pattern ⁽⁴⁾	0'h	R/W	000 = CRPAT 001 = CJPAT 010 = PRBS23 with 9 /K/s as IPG 011 = Short PRBS23 pattern ⁽²⁾ 100 = Jumbo Ethernet packet ⁽³⁾ Other = reserved
3.49164.7	BIST_DET	BIST checker enable	0'b	R/W	1 = Enable BIST checker 0 = Disable BIST checker
3.49164.6:4	Reserved				
3.49164.3	BIST_SRC	Select BIST data checker input source	0'b	R/W	0 = PCS to BIST (receive path) 1 = XGXS to BIST (transmit path)
3.49164.2:0	BIST_CHK	Select BIST checker data pattern ⁽⁵⁾	0'h	R/W	000 = CRPAT 001 = CJPAT 010 = PRBS23 with /K/s as IPG 011 = Short PRBS23 pattern ⁽²⁾ 100 = Jumbo Ethernet packet ⁽³⁾ Other = reserved

Note (1): See "BIST Operation" on page 53 for a description of these tests and patterns.

Note (2): This Short pattern is the first 13458 Bytes of the full PRBS 2²³-1 Byte pattern, and also has 9 /K/ per lane as IPG

Note (3): This pattern is an /S/, preamble, the 'Short PRBS23' pattern, one /T/, and 9 /K/s, repeated.

Note (4): A Soft Reset is required to activate the newly selected pattern.

Note (5): The checker expects at least one /K/ on each lane between pattern repeats

Table 73. BIST ERROR COUNTER REGISTERS

MDIO REGISTER ADDRESSES = 3.49165:6 (3.C00D:E'h)					
BIT	NAME	SETTING	DEFAULT	R/W	DESCRIPTION
3.49165.15:8	BIST_ERR_CNT_3	Lane 3 errors	00'h	RCNR ⁽¹⁾	Error byte counter of BIST pattern checker on each Lane
3.49165.7:0	BIST_ERR_CNT_2	Lane 2 errors	00'h	RCNR ⁽¹⁾	
3.49166.15:8	BIST_ERR_CNT_1	Lane 1 errors	00'h	RCNR ⁽¹⁾	
3.49166.7:0	BIST_ERR_CNT_0	Lane 0 errors	00'h	RCNR ⁽¹⁾	

Note (1): The counters do not rollover at FF'h, and are cleared on read. There is also an error flag bit, see register 4.C007, Table 88.

Table 74. MDIO PHY XS DEVAD 4 REGISTERS

PHY XS DEVICE 4 MDIO REGISTERS							
ADDRESS		NAME	DESCRIPTION	DEFAULT	AC (2)	R/W	DETAILS
DEC	HEX						
4.0	4.0	PHYXS Control 1	Reset, Enable loop back mode.	2040'h		R/W	Table 75
4.1	4.1	PHYXS Status 1	PCS Fault, Link Status	0004'h ⁽³⁾		RO (LL)	Table 76
4.2:3	4.2:3	ID Code	Manufacturer and Device OUI	01839C6V'h		RO	See ⁽¹⁾
4.4	4.4	Speed Ability	10Gbps Ability	0001'h		RO	Table 7
4.5	4.5	IEEE Devices	Devices in Package, Clause 22 capable	001A'h		RO	Table 8
4.6	4.6	Vendor Devices	Vendor Specific Devices in Pkg	0000'h		RO	Table 8
4.8	4.8	PHYXS Status 2	Device Present, Local Fault, Type Summary	8000'h ⁽³⁾		RO	Table 77
4.14:15	4.E:F	Package ID	Package OUI, etc.	00000000'h		RO	See ⁽⁴⁾
4.24	4.18	PHYXS Status 3	10GBASE-X PHY XGXS Status	1C0F'h		RO	Table 78
4.25	4.19	PHYXS Test	10GBASE PHY XS Test Control	0000'h		R/W	Table 79
4.49152	4.C000	PHYXS Control 2	PHY XS Control Register 2	0F6F'h	A	R/W	Table 80
4.49153	4.C001	PHYXS Control 3	PHY XS Control Register 3	0800'h	A	R/W	Table 81
4.49154	4.C002	PHYXS ERR	PHY XS Internal ERROR code register	00FE'h	A	R/W	Table 82
4.49155	4.C003	PHYXS IDLE	PHY XS Internal IDLE Code Register	0007'h	A	R/W	Table 83
4.49156	4.C004	PHYXS Loop Back	PHY XS Loop Back Control Register	0000'h	A	R/W	Table 84
4.49157	4.C005	PRE_EMPH	PHY XS Pre-emphasis level	0000'h	A	R/W	Table 85
4.49158	4.C006	Equalization	PHY XS Equalization Control	0000'h	A	R/W	Table 87
4.49159	4.C007	Test_Flags	PHY XS Receive Path Test & Status Flags	0000'h		RO LH	Table 88
4.49160	4.C008	Output Ctrl	Output Control and Test function	AAAA'h		R/W	Table 89
4.49161	4.C009	Half Rate	Half rate clock mode enable	0000'h		R/W	Table 71
4.49162	4.C00A	LOS Det	PHY XS Status 4 LOS Register	0000'h		RO LH	Table 90
4.49163	4.C00B	Reserved	PHY XS Control 4 TXCLK20	0000'h		R/W	Table 91
4.49167	4.C00F	Soft Reset	Reset (non MDIO)	0000'h		R/W SC	Table 46

Note (1): 'V' is a version number. See "JTAG & AC-JTAG Operations" on page 53 for a note about the version number.

Note (2): For rows with "A", the default value may be overwritten by the Auto-Configure operation (See "Auto-Configuring Control Registers" on page 16 and Table 92 for details).

Note (3): Read value depends on status signal values. Value shown indicates 'normal' operation.

Note (4): The IEEE 802.3ae spec allows this to be all zeroes. A XENPAK (etc.) host can more readily determine where the NVR registers are if this value is zero.

IEEE PHY XS REGISTERS (4.0 TO 4.25/4.0019'H)

Table 75. IEEE PHY XS CONTROL 1 REGISTER

MDIO REGISTER ADDRESS = 4.0 (4.0000'h)					
BIT(S)	NAME	SETTING	DEFAULT	R/W	DESCRIPTION
3.0.15 1.0.15 4.0.15	Reset	1 = reset 0 = reset done, normal operation	0'b	R/W SC	Writing 1 to this bit will reset the whole chip, including the MDIO registers.
4.0.14	PHY XS Loopback	1 = Enable loopback 0 = Normal operation	0'b	R/W	Enable PHY XS loop back mode on all four lanes.
3.0.13 4.0.13	Speed Select	1 = 10Gbps	1'b	RO	Operates at 10Gbps & above
4.0.12	Reserved		00'h		
4.0.11	LOPOWER	0 = Normal Power	0'b	R/W	No Low Power Mode, writes ignored
4.0.10:7	Reserved				
3.0.6 4.0.6	Speed Select	1 = 10Gbps	1'b	RO	Operates at 10Gbps & above
3.0.5:2 4.0.5:2	Speed Select	0000 = 10Gbps	0'h	RO	Operates at 10Gbps
4.0.1:0	Reserved		0'b		

Table 76. IEEE PHY XS STATUS 1 REGISTER

MDIO REGISTER ADDRESS = 4.1 (4.0001'h)					
BIT	NAME	SETTING	DEFAULT	R/W	DESCRIPTION
4.1.15:8	Reserved		00'h		
4.1.7	Local Fault	1 = PHY XS Local Fault	0	RO	Derived from Register 4.0008'h
4.1.6:3	Reserved		0'h		
4.1.2	Tx Link Up	1 = XGXS Tx Link Up 0 = XGXS Tx Link Down	1 ⁽¹⁾	RO LL ⁽¹⁾	'Up' means XAUI-side signal level is OK, Byte Synch and Lane-Lane Alignment have all occurred
4.1.1	LoPwrAble	Low Power Ability	0	RO	Device does not support a low power mode
4.1.0	Reserved		0		

Note (1): This bit is latched low on a detected Fault condition. It is set high on being read.

Table 77. IEEE PHY XS STATUS 2 DEVICE PRESENT & FAULT SUMMARY REGISTER

MDIO REGISTER ADDRESSES = 4.8 (4.0008'h)					
BIT	NAME	SETTING	DEFAULT	R/W	DESCRIPTION
4.8.15:14	Device present	10 = Device present	10'b	RO	When read as "10", it indicates that a device is present at this device address
4.8.13:12	Reserved				
4.8.11	TX LocalFit	1 = TX Local Fault; on Egress channel	0'b	RO/ LH ⁽¹⁾	Lane Alignment or Byte Alignment not done, or Loss of Signal. From Reg. 4.24
4.8.10	RX LocalFit	1 = RX Local Fault; on Ingress channel	0'b	RO/ LH ⁽¹⁾	PLL lock failure (lack of RFCP/N signal)
4.8.9:0	Reserved				

Note (1): These bits are latched high on any Fault condition detected. They are reset low (cleared) on being read. They will also be reset low on reading the LASI registers 1.9003'h (bit 10, see Table 27) or 1.9004'h (bit 11, see Table 28)

Table 78. IEEE 10GBASE-X PHY XGXS STATUS REGISTER

MDIO REGISTER ADDRESSES = 4.24 (4.0018'h)					
BIT	NAME	SETTING	DEFAULT	R/W	DESCRIPTION
4.24.15:13	Reserved				
4.24.12	PHY XS Lane_Align	1 = 4 Lanes Aligned 0 = Lanes not aligned	1'b ⁽¹⁾	RO	1 = Four 3G receive lanes (on egress path) are aligned
4.24.11	Test_Pattern	Test Pattern Abilities	1'b	RO	1 = The device is able to generate test patterns for 10GBASE-X
4.24.10	PHYXSLpbk	Loopback Ability	1'b	RO	1 = Device is able to loopback
4.24.9:4	Reserved				
4.24.3	Lane3 Sync	1 = Lane is Synchronized 0 = Lane not Synchronized	1'b ⁽¹⁾	RO	Reflects the PCS_SYNC byte alignment state machine condition; not valid if not enabled in device (see Table 80)
4.24.2	Lane2 Sync		1'b ⁽¹⁾	RO	
4.24.1	Lane1 Sync		1'b ⁽¹⁾	RO	
4.24.0	Lane0 Sync		1'b ⁽¹⁾	RO	

Note (1): The status of these bits depends on the signal conditions. Default shown is for normal operation. The bits contribute to the RX Local Fault bit, see Table 77.

Table 79. IEEE 10GBASE-X PHY XGXS TEST CONTROL REGISTER

MDIO REGISTER ADDRESS = 4.25 (4.0019'h)					
BIT	NAME	SETTING	DEFAULT	R/W	DESCRIPTION
4.25.15:3	Reserved				
4.25.2	PHY XS TestPatEn	Receive Test Pattern Enable	0'b	R/W	0 = Do not enable Receive test pattern 1 = Enable Receive test pattern
4.25.1:0	PHY XS TestPat Type	Test pattern select (see Table 72 for other test patterns generated by the BBT3821)	00'b	R/W	11 = Reserved 10 = Mixed frequency test pattern (Continuous /K/ = K28.5) 01 = Low frequency test pattern (repeat 0000011111 = K28.7) 00 = High frequency test pattern (repeat 0101010101 = D10.2)

VENDOR-SPECIFIC PHY XS REGISTERS (4.C000'H TO 4.C00B'H)**Table 80. PHY XS CONTROL REGISTER 2**

MDIO REGISTER ADDRESS = 4.49152 (4.C000'h)					
BIT	NAME	SETTING	DEFAULT ⁽¹⁾	R/W	DESCRIPTION
4.49152.15:14	Test Mode	00'b	00'b	R/W	User should leave at 00'b
4.49152.13:12	Reserved				
4.49152.11	PHY XS Clock PSYNC		1'b	R/W	1 = Synchronize/align four lanes 0 = Do not synchronize/align four lanes
4.49152.10	PHY XS CODECENA	0 = disable 1 = enable	1'b	R/W	Internal 8B/10B Codec enable/disable
4.49152.9:8	PHY XS CDET[1:0]	Comma Detect Select.	11'b	R/W	These bits individually enable positive and negative disparity "comma" detection. 11 = Enable both positive and negative comma detection 10 = Enable positive comma detection only 01 = Enable negative comma detection only 00 = Disable comma detection
4.49152.7	PHY XS DSKW_SM_EN	0 = disable ⁽²⁾ 1 = enable	0'b	R/W	Enable De-skew state machine control ⁽³⁾ . Forced enabled by PHY XS XAU1_EN. May not operate correctly unless the PHY XS PCS_SYNC_EN bit is also set.
4.49152.6:5	PHY XS RCLKMODE	11'b = Local Reference Clock ⁽⁴⁾	11'b	R/W	Other values should only be used if incoming data is frequency-synchronous with the local reference clock ⁽⁴⁾ .

Table 80. PHY XS CONTROL REGISTER 2 (Continued)

MDIO REGISTER ADDRESS = 4.49152 (4.C000'h)					
BIT	NAME	SETTING	DEFAULT ⁽¹⁾	R/W	DESCRIPTION
4.49152.4	PHY XS PCS_SYNC_EN ⁽⁵⁾	0 = disable ⁽²⁾ 1 = enable	0'b	R/W	Enable 8b/10b PCS coding synchronized state machine ⁽³⁾ to control the byte alignment (IEEE 'code-group alignment') of the high speed de-serializer
4.49152.3	PHY XS IDLE_D_EN	1 = enable 0 = disable	1'b	R/W	Enables IDLE vs. NON-IDLE detection for lane alignment. Overridden by PHY XS XAUI_EN, see Table 88
4.49152.2	PHY XS ELST_EN	1 = enable 0 = disable	1'b	R/W	Enable the elastic function of the PHY XS receiver buffer
4.49152.1	PHY XS A_ALIGN_DIS	1 = disable ⁽²⁾ 0 = enable	1'b	R/W	PHY XS Receiver aligns data on incoming "/A/" characters (K28.3). If disabled (default), receiver aligns data on IDLE to non-IDLE transitions (if bit 3 set). Overridden by PHY XS XAUI_EN, see Table 81
4.49152.0	PHY XS CAL_EN	1 = enable 0 = disable	1'b	R/W	Enable de-skew calculator of PHY XS receiver Align FIFO

Note (1): The values may be overwritten by the Auto-Configure operation (See "Auto-Configuring Control Registers" on page 16 and Table 92 for details).

Note (2): These bits are overridden by PHY XS XAUI_EN, see Table 81 and Table 65.

Note (3): These state machines are implemented according to 802.3ae-2002 clause 48.

Note (4): If the RCLKMODE bits are set to 10'b, the internal XGMII clock from the PHY XS to the PCS is set to the recovered clock. If the PHY XS Clock PSYNC bit is set (the default), the recovered clock from Lane 0 is used for all four lanes, if cleared, or if the RCLKMODE bits are set to 01'b or 00'b, each lane uses its own recovered clock. If the incoming data is NOT frequency-synchronous with the local reference clock, data will be corrupted (occasional characters will be lost, or repeated).

Note (5): This bit name reflects the "embedded" PCS function within an XGXS, see IEEE 802.3 Clause 47.2.1.

Table 81. PHY XS CONTROL REGISTER 3

MDIO REGISTER ADDRESS = 4.49153 (4.C001'h)					
BIT	NAME	SETTING	DEFAULT ⁽¹⁾	R/W	DESCRIPTION
4.49153.15	PHY XS DC_O_DIS	1 = Disable, 0 = normal	0'b	R/W	PHY XS DC Offset Disable
4.49153.14:13	Reserved				
4.49153.12	MF_SEL	Select source of signals for four MF pins	0'b	R/W	1 = Select signals from PMA/PCS to be output on MF pins 0 = Select signals from PHY XGXS to be output on MF pins
4.49153.11	PHY XS XAUI_EN	1 = enable 0 = disable	1'b	R/W	Enables all XAUI features per 802.3ae-2002. It is equivalent to setting the configuration bits listed in Table 65 (but does not change the actual value of the corresponding MDIO registers' bits).
4.49153.10:8	PHY_LOS_TH	0'h = 160mV _{p-p} 1'h = 240mV _{p-p} 2'h = 200mV _{p-p} 3'h = 120mV _{p-p} 4'h = 80mV _{p-p} else = 160mV _{p-p}	000'b	R/W	Set the threshold voltage for the Loss Of Signal (LOS) detection circuit in PHY XS. Nominal levels are listed for each control value. Note that the differential peak-to-peak value is twice that listed
4.49153.7	Reserved				
4.49153.6	PHY XS AKR_SM_EN	1 = enable random A/K/R 0 = /K/ only ⁽²⁾	0'b	R/W	Enable pseudo-random A/K/R ⁽³⁾ in Inter Packet Gap (IPG) on transmitter side (vs. /K/ only)
4.49153.5	PHY XS TRANS_EN	1 = enable 0 = disable ⁽²⁾ Overridden by PHY XS XAUI_EN, see Table 65	0'b	R/W	This bit enables the transceiver to translate an "IDLE" pattern in the internal FIFOs (matching the value of register 4.C003'h) to and from the XAUI IDLE /K/ comma character or /A/, /K/ & /R/ characters.
4.49153.4	Reserved				
4.49153.3	PHY XS TX_SDR	PHY XS receive data rate	0'b	R/W	1 = PHY XS takes data from PCS at half speed 0 = PHY XS takes data from PCS at full speed

Table 81. PHY XS CONTROL REGISTER 3 (Continued)

MDIO REGISTER ADDRESS = 4.49153 (4.C001'h)					
BIT	NAME	SETTING	DEFAULT ⁽¹⁾	R/W	DESCRIPTION
4.49153.2:0	MF_CTRL	0 = BIST_ERR 1 = LOS 2,3 = Reserved 4 = TXFIFO_ERR 5 = AFIFO_ERR 6 = EFIFO_ERR	000'b	R/W	Control the meaning of Multi-function pins MF[3:0] of the 4 lanes in the device selected by MF_SEL above (bit 12)

Note (1): The values may be overwritten by the Auto-Configure operation (See "Auto-Configuring Control Registers" on page 16 and Table 92 for details).

Note (2): These bits are overridden by PHY XS XAUI_EN, see also Table 65.

Note (3): This state machine is implemented according to IEEE 802.3ae-2002 clause 48.

Table 82. PHY XS INTERNAL ERROR CODE REGISTER

MDIO REGISTER, ADDRESS = 4.49154 (4.C002'h)					
BIT	NAME	SETTING	DEFAULT ⁽¹⁾	R/W	DESCRIPTION
4.49154.15:8	Reserved				
4.49154.7:0	PHY XS ERROR	Desired Value ⁽²⁾	FE'h	R/W	Error Code. These bits allow the internal FIFO ERROR control character to be programmed.

Note (1): The values may be overwritten by the Auto-Configure operation (See "Auto-Configuring Control Registers" on page 16 and Table 92 for details).

Note (2): These bits are overridden to FE'h by PHY XS XAUI_EN, see Table 65 and Table 81.

Table 83. PHY XS INTERNAL IDLE CODE REGISTER

MDIO REGISTER ADDRESS = 4.49155 (4.C003'h)					
BIT	NAME	SETTING	DEFAULT ⁽¹⁾	R/W	DESCRIPTION
4.49155.15:8	Reserved				
4.49155.7:0	PHY XS XG_IDLE	Desired Value	07'h	R/W	IDLE pattern in internal FIFOs for translation to/from XAUI IDLEs

Note (1): The default value may be overwritten by the Auto-Configure operation (See "Auto-Configuring Control Registers" on page 16 and Table 92 for details).

Table 84. PHY XS MISCELLANEOUS LOOP BACK CONTROL REGISTER

MDIO REGISTER ADDRESS = 4.49156 (4.C004'h)					
BIT	NAME	SETTING	DEFAULT	R/W	DESCRIPTION
4.49156.15:13	Reserved				
4.49156.12	Test LP	1 = enable	0'b ⁽¹⁾	R/W	Serial Host Test Loopback
4.49156.11	SLP_3	1 = enable PHY XS Network Loopback 0 = disable	0'b ⁽²⁾	R/W	Internal PHY XS Serial Loop Back Enable for each individual lane. When high, it routes the internal XAUI Serial output to the Serial input.
4.49156.10	SLP_2		0'b ⁽²⁾		
4.49156.9	SLP_1		0'b ⁽²⁾		
4.49156.8	SLP_0		0'b ⁽²⁾		
4.49156.7:4	Reserved				
4.49156.3	PLP_3	1 = enable System ("PCS") Parallel Loopback 0 = disable	0'b ⁽²⁾	R/W	PCS Parallel Loop Back Enable for each individual lane. When high, it routes the XAUI Serial input to the Serial output via the full PHY XS.
4.49156.2	PLP_2		0'b ⁽²⁾		
4.49156.1	PLP_1		0'b ⁽²⁾		
4.49156.0	PLP_0		0'b ⁽²⁾		

Note (1): Loopback is from XAUI Serial I/P to Serial O/P. Recommended use for test purposes only; no retiming or pre-emphasis is performed

Note (2): These values may be overwritten by the Auto-Configure operation (See "Auto-Configuring Control Registers" on page 16 and Table 92 for details).

Table 85. PHY XS PRE-EMPHASIS CONTROL

MDIO REGISTER ADDRESS = 4.49157 (4.C005'h)					
BIT	NAME	SETTING	DEFAULT ⁽¹⁾	R/W	DESCRIPTION
4.49157.15:12	Reserved				
4.49157.11:9	PRE_EMP Lane 3	See Table 86 for settings	0'h	R/W	Configure the level of PHY XS pre-emphasis (nominal levels indicated)
4.49157.8:6	PRE_EMP Lane 2		0'h		
4.49157.5:3	PRE_EMP Lane 1		0'h		
4.49157.2:0	PRE_EMP Lane 0		0'h		

Note (1): The values may be overwritten by the Auto-Configure operation (See "Auto-Configuring Control Registers" on page 16 and Table 92 for details).

Table 86. PHY XS XAUI PRE-EMPHASIS CONTROL SETTINGS

ADDRESS 4.C005'h BITS 2:0	PRE-EMPHASIS ⁽¹⁾ (802.3ak) = (1-V _{Low} /V _{Hi})	PRE-EMPHASIS VALUE = (V _{Hi} / V _{Low})-1	ADDRESS 4.C005'h BITS 2:0	PRE-EMPHASIS (802.3ak) = (1-V _{Low} /V _{Hi})	PRE-EMPHASIS VALUE = (V _{Hi} / V _{Low})-1
000	0	0	100	0.50	1.00
001	0.17	0.20	101	0.53	1.28
010	0.28	0.39	110	0.57	1.33
011	0.44	0.79	111	0.60	1.50

Note (1): See Note (2) to Table 42 for a note about the equations and symbols used here.

Table 87. PHY XS EQUALIZATION CONTROL

MDIO REGISTER ADDRESS = 4.49158 (4.C006'h)					
BIT	NAME	SETTING	DEFAULT ⁽¹⁾	R/W	DESCRIPTION
4.49158.15:14	Reserved				
4.49158.3:0	PHY XS EQ_COEFF	0'h = no boost in equalizer. F'h = boost is maximum	0'h	R/W	Configuration of the PHY XS equalizer

Note (1): The value may be overwritten by the Auto-Configure operation (See "Auto-Configuring Control Registers" on page 16 and Table 92 for details).

Table 88. PHY XS RECEIVE PATH TEST AND STATUS FLAGS

MDIO REGISTER ADDRESS = 4.49159 (4.C007'h)					
BIT	NAME	SETTING	DEFAULT	R/W	DESCRIPTION
4.49159.15:12	Test Flags		0'h	ROLH	Special test use only
4.49159.11	EFIFO_3	1 = EFIFO error in Lane 0 = no EFIFO error in Lane	0'b	ROLH	PHY XS Elasticity FIFO Overflow/Underflow Error Detection ⁽¹⁾
4.49159.10	EFIFO_2		0'b		
4.49159.9	EFIFO_1		0'b		
4.49159.8	EFIFO_0		0'b		
4.49159.7	Code_3	1 = 10b/8b Code error in Lane 0 = no 10b/8b Code error	0'b	ROLH	PHY XS 10b/8b Decoder Code Violation Detection ⁽¹⁾
4.49159.6	Code_2		0'b		
4.49159.5	Code_1		0'b		
4.49159.4	Code_0		0'b		
4.49159.3	BIST_ERR_3	1 = BIST error in lane 0 = No BIST error in lane	0'b	ROLH	Lane by lane BIST error checker indicator ^{(1) (2)}
4.49159.2	BIST_ERR_2		0'b		
4.49159.1	BIST_ERR_1		0'b		
4.49159.0	BIST_ERR_0		0'b		

Note (1): These bits are latched high on any Fault condition detected. They are reset low (cleared) on being read. They will also be reset low on reading the LASI register 1.9004'h (see Table 28)

Note (2): See also error counters in registers 3.C00D:E'h (Table 73)

Table 89. PHY XS OUTPUT AND TEST FUNCTION CONTROL REGISTER

MDIO REGISTER ADDRESS = 4.49160 (4.C008'h)					
BIT	NAME	SETTING	DEFAULT	R/W	DESCRIPTION
4.49160.15:14	Reserved		10'b	R/W	Test Function, do not alter
4.49160.13	ENA_3	Enable Lane 3 O/P	1'b	R/W	0 = disable
4.49160.12:10	Reserved		010'b	R/W	Test Function, do not alter
4.49160.9	ENA_2	Enable Lane 2 O/P	1'b	R/W	0 = disable
4.49160.8:6	Reserved		010'b	R/W	Test Function, do not alter
4.49160.5	ENA_1	Enable Lane 1 O/P	1'b	R/W	0 = disable
4.49160.12:10	Reserved		010'b	R/W	Test Function, do not alter
4.49160.1	ENA_0	Enable Lane 0 O/P	1'b	R/W	0 = disable
4.49160.0	Reserved		0'b	R/W	Test Function, do not alter

Table 90. PHY XS STATUS 4 LOS DETECTOR REGISTER

MDIO REGISTER ADDRESS = 4.49162 (4.C00A'h)					
BIT	NAME	SETTING	DEFAULT	R/W	DESCRIPTION
4.49162.15:4	Reserved		00'b		
4.49162.3	PHY_LOS_3	1 = Signal less than threshold 0 = Signal greater than threshold	0'b	RO/LH ⁽¹⁾	Loss Of Signal for lane 3
4.49162.2	PHY_LOS_2		0'b		Loss Of Signal for lane 2
4.49162.1	PHY_LOS_1		0'b		Loss Of Signal for lane 1
4.49162.0	PHY_LOS_0		0'b		Loss Of Signal for lane 0

Note (1): These bits are latched high on any LOS condition detected. They are reset low on being read.

Table 91. PHY XS CONTROL REGISTER 4

MDIO REGISTER ADDRESS = 4.49163 (4.C00B'h)					
BIT	NAME	SETTING	DEFAULT	R/W	DESCRIPTION
4.49163.15:2	Reserved		00'h		
4.49163.1	TXCLK20	0 = disable 1 = enable	0'b	R/W	TXCLK20 pin output
4.49163.0	Test	Internal	0'b	R/W	User must keep at 0'b

Auto-Configure Register List

Table 92. AUTO-CONFIGURE REGISTERS

Auto-configure Pointer is (S), Auto-configure Size is (N), from 1.8106'h & 1.8105'h respectively

NVR ADDRESS		TARGET REGISTER BITS ADDRESS ⁽¹⁾		TARGET NAME ⁽¹⁾	DETAILS
DEC	HEX	DEC	HEX		
S + 0	S + 0	4.49158.[3:0]	4.C006.[3:0]	PHY XS Equalizer Value	Table 87
S + 1	S + 1	4.49157.[7:0]	4.C005.[7:0]	PHY XS Pre-emphasis Lanes 1:0	Table 85
S + 2	S + 2	4.49157.[15:8]	4.C005.[15:8]	PHY XS Pre-emphasis Lanes 3:2	
S + 3	S + 3	1.49158.[3:0]	1.C006.[3:0]	PMA/PMD Equalizer Value	Table 43
S + 4	S + 4	1.49157.[7:0]	1.C005.[7:0]	PMA/PMD Pre-emphasis Lanes 1:0	Table 41
S + 5	S + 5	1.49157.[15:8]	1.C005.[15:8]	PMA/PMD Pre-emphasis Lanes 3:2	
S + 6	S + 6	1.36864.[6:0].	1.9000.[6:0]	LASI RX Alarm Control	Table 24

Table 92. AUTO-CONFIGURE REGISTERS (Continued)

Auto-configure Pointer is (S), Auto-configure Size is (N), from 1.8106'h & 1.8105'h respectively

NVR ADDRESS		TARGET REGISTER BITS ADDRESS ⁽¹⁾		TARGET NAME ⁽¹⁾	DETAILS
DEC	HEX	DEC	HEX		
S + 7	S + 7	1.36865.[7:0]	1.9001.[7:0]	LASI TX Alarm Control	Table 25
S + 8	S + 8	1.36865.[10:8] & 1.36866.[3:0]	1.9001.[10:8], 1.9002.[3:0]	LASI TX Alarm & LASI Control	Table 25 & Table 26
S + 9	S + 9	1.36870.	1.9006	DOM TX flag control	Table 30
S + 10	S + A	1.36871.	1.9007	DOM RX flag control	Table 31
S + 11	S + B	1.49170.[1:0], 1.49168.[5:0]	1.C012.[1:0], 1.C010.[5:0]	GPIO LASI & Pin Direction Configuration	Table 49 & Table 47
S + 12	S + C	1.49170.[11:8,5:2],	1.C012.[11:8,5:2]	GPIO LASI control	Table 49
S + 13	S + D	1.49170.[13:12], 1.49171.[5:0]	1.C012.[13:12], 1.C013.[5:0]	TX_FAULT polarity, GPIO LASI & Output Control	Table 49 & Table 50
S + 14	S + E	1.49176	1.C018	DOM Control	Table 51
S + 15	S + F	1.49177.[7:0]	1.C019.[7:0]	Indirect DOM Mem Address Lane2	Table 53
S + 16	S + 10	1.49177.[15:8]	1.C019.[15:8]	Indirect DOM Mem Address Lane3	
S + 17	S + 11	1.49178.[7:0]	1.C01A.[7:0]	Indirect DOM Mem Address Lane0	
S + 18	S + 12	1.49178.[15:8]	1.C01A.[15:8]	Indirect DOM Mem Address Lane1	
S + 19	S + 13	1.49179.[7:0]	1.C01B.[7:0]	Indirect DOM Dev Address Lane2	Table 54
S + 20	S + 14	1.49179.[15:8]	1.C01B.[15:8]	Indirect DOM Dev Address Lane3	
S + 21	S + 15	1.49180.[7:0]	1.C01C.[7:0]	Indirect DOM Dev Address Lane0	
S + 22	S + 16	1.49180.[15:8]	1.C01C.[15:8]	Indirect DOM Dev Address Lane1	
S + 23	S + 17	1.49181.[7:0]	1.C01D.[7:0]	Optical I/F Pin Polarity Control	Table 55
S + 24	S + 18	4.49152.[7:0]	4.C000.[7:0]	PHY XS control 2	Table 80
S + 25	S + 19	4.49152.[15:8]	4.C000.[15:8]	PHY XS control 2	
S + 26	S + 1A	4.49153.[7:0]	4.C001.[7:0]	PHY XS control 3	Table 81
S + 27	S + 1B	4.49153.[15:8]	4.C001.[15:8]	PHY XS control 3	
S + 28	S + 1C	4.49154.[7:0]	4.C002.[7:0]	PHY XS Error Code	Table 82
S + 29	S + 1D	4.49155.[7:0]	4.C003.[7:0]	PHY XS IDLE Code	Table 83
S + 30	S + 1E	4.49156.[11:8,3:0]	4.C004.[11:8,3:0]	PHY XS Loopback Control	Table 85
S + 31	S + 1F	3.49152.[7:0]	3.C000.[7:0]	PCS control 2	Table 63
S + 32	S + 20	3.49152.[15:8]	3.C000.[15:8]	PCS control 2	
S + 33	S + 21	3.49153.[7:0]	3.C001.[7:0]	PCS control 3	Table 64 & Table 39 ⁽²⁾
S + 34	S + 22	1:3.49153.[15:8]	1:3.C001.[15:8]	PCS control 3/PMA control 2	
S + 35	S + 23	3.49154.[7:0]	3.C002.[7:0]	PCS Error Code	Table 66
S + 36	S + 24	3.49155.[7:0]	3.C003.[7:0]	PCS IDLE Code	Table 67
S + 37	S + 25	1.49156.[11:8] 3.49156.[3:0]	1.C004.[11:8] 3.C004.[3:0]	PCS/PMA Loopback Control	Table 40 & Table 68 ⁽³⁾
S + 38	S + 26	1.49163.[9:2]	1.C00B.[9:2]	Miscellaneous Adjustments	Table 45
S + 39	S + 27	4.49163.[9:2]	4.C00B.[9:2]	BitBlitz Internal Test Control	Table 91

Note (1): The 8 bits of the NVR register (7:0) are mapped to the listed bits of the target in order. Unused bits are always at the MSb (bit 7) end.

Note (2): The target register pair are overlapped, ignoring the 'reserved' bits in one where used bits occur in the same location in the other. Thus the mapping from the NVR register is: 1.C001.[15:12], 3.C001.11, 1.C001.[10:8].

Note (3): The mapping from the NVR register is: 1.C004.[11:8], 3.C004.[3:0]

JTAG & AC-JTAG Operations

Five pins – TMS, TCK, TDO, TRST, and TDI – support IEEE Standards 1149.1-2001 JTAG and 1149.6-2003 AC-JTAG testing. The JTAG test capability has been implemented on all signal pins. Note that the 1149.1-2001 specification has removed the previous requirement that the [000...0] instruction be an entry into EXTEST, and deprecated its use for anything but a non-test function (e.g. BYPASS). The BBT3821 fully conforms to this revision. The AC-JTAG test capability has been implemented on the high-speed differential output and input terminals. The output configuration corresponds to Figure 51 in IEEE 1149.6-2003, except that there is no provision to bring the ‘mission’ signal into the scan chain, since this 3.125Gbps signal has no meaningful value at the (asynchronous) JTAG TCK rate, and the BBT3821 does not support INTEST. The receiver configuration corresponds to Figure 48, using the DC detection mode only, according to method 2 of 6.2.3.1 rule a), and omitting the components needed only for the unsupported INTEST instruction. The EXTEST_PULSE and EXTEST_TRAIN instruction timings are illustrated in Figures 37, 38 and 44 while the (DC) EXTEST waveforms are indicated in Figure 42 in IEEE 1149.6-2003. Provided that the TCK period is sufficiently longer than the AC-coupling time constant, controlled by the (external) capacitors and the input impedance of the BBT3821, (see IEEE 1149.6-2003 clause 6.2.3.1 rule k), the combination of (DC) EXTEST and EXTEST_PULSE or EXTEST_TRAIN scans can detect open or shorted capacitors or wires.

The supported boundary scan operation instruction codes are listed in Table 93:

Table 93. JTAG OPERATIONS

INSTRUCTION	CODE
BYPASS ⁽¹⁾	0000
Sample/Preload	0001
HighZ	0010
Clamp	0011
ID Code	0110
EXTEST	1000
UDR0	1001
EXTEST_PULSE	1011
EXTEST_TRAIN	1100
BYPASS	1111

Note (1): All non-listed codes are also BYPASS.

The Manufacturers ID Code returned when reading the ID Code from the JTAG pins is as follows:-

V0006351'h

where ‘V’ is an internal 4-bit version number. Consult the “Intersil Corporation Contact Information” on page 75 for information as to the meaning of the revision number.

Note that the JTAG and AC-JTAG capability is not currently tested in production.

BIST Operation

In addition to the low, mid and high frequency test patterns defined in IEEE 802.3ae-2002, which are injected (at the 10-bit level) directly into the serializers, and controlled via the “IEEE 10GBASE-X PCS TEST CONTROL REGISTER” on page 40 and the “IEEE 10GBASE-X PHY XGXS TEST CONTROL REGISTER” on page 47, and to further facilitate the exercise of all the BT3821 blocks, the device includes a Built In Self Test (BIST) function. The BIST Data Package Generator sends out a continuous data stream to emulate network traffic. The available BIST data patterns are enabled via the bits in Table 72. The patterns available are:

1. CRPAT pattern per IEEE802.3ae-2002 Annex 48A
2. CJPAT pattern per IEEE802.3ae-2002 Annex 48A
3. A full PRBS23 pattern ($2^{23}-1$ coded bytes, 10 times that many bits) with nine /K/ “comma” characters as interval on each XAUI/CX4 lane.
4. A Short Pseudo-Random data pattern (13458 byte long) with nine /K/ “comma” characters as interval on each XAUI/CX4 lane.
5. Emulation of an Ethernet Jumbo frame: ||S|| + preamble + Random data (4 x 13458 byte long) + ||T|| + IPG;

The ‘PRBS23’-based patterns are derived from a PRBS generator that, after an Inter-Packet Gap (‘IPG’) of 9 /K/ characters, creates a pseudo-random $2^{23} - 1$ byte sequence. The full sequence is used for the ‘PRBS23’ pattern, while the ‘Short PRBS23’ pattern is truncated after 13458 bytes. Each will start again from the beginning, repeating indefinitely. This pattern is generated on each lane, and checked (except for the /K/s, of which one is required for byte synchronization, but all the others are ignored) in the same way.

The ‘Jumbo Ethernet Packet’ is similar, except that the ‘Short PRBS23’ pattern is preceded by an /S/ & one preamble on Lane 0, two preambles on Lanes 1 & 2, and a preamble and SFD on Lane 3, and followed by a /T/ on lane 0. Apart from providing byte sync (byte alignment), the /K/-filled IPG allows for lane alignment (using the IDLE-to-NONIDLE transition alignment engine) and elasticity (by deleting or adding the requisite number of /K/s). The latter, in particular, allows one BBT3821 to check the ‘Short PRBS23’ or ‘Jumbo Ethernet Packet’ generated by another BBT3821 running on an independent clock within ± 100 ppm. The full PRBS23 pattern could be over 300 bytes off in one repeat

under these circumstances, greatly exceeding the elasticity FIFO's range, unless the clocks were synchronized. The CJPAT and CRPAT patterns are those defined by IEEE 802.3ae-2002 Annex 48.

Either the BIST_EN bit (see Table 72) or the BIST_ENA pin (see Table 99 on Page 56) will cause the Serial Transmitter selected by the BIST_DIR bit to put out the pattern selected by the BIST_PAT bits (see Table 72). The BIST_DET bit will enable the Serial Receiver selected by the BIST_SRC bit to search its incoming bit stream for the pattern (separately) selected by the BIST_CHK bits (see Table 72). Once the comma group or IPG has set the byte alignment, the BIST error detector will be enabled, and the decoded pattern will be then be checked. Any bit error will set the error detector for the corresponding lane, and increment the BIST_ERR_CNT counters (see Table 73). These detectors may be monitored via the MF[3:0] pins (see Table 99) and both they and the counters may be read via the MDIO system (see Table 81).

The separate setup for BIST generation and checking means that two BBT3821s may be tested with a different pattern in each direction on the link between them.

The signal flows provided for these BIST patterns are shown in Figure 6. The generator output may be injected (in place of the 'normal' signal flow) into the AKR Randomizer in either the PCS or PHY XS, as controlled by the "BIST CONTROL REGISTER" (see Table 72). The signal may be looped back using the PMA or PHY XS loopbacks (respectively), and checked at the output of the respective Elastic FIFO, or continue on to the other loopback, and checked at the output of the other Elastic FIFO. The internal loopback(s) may be replaced by external loopbacks, and in each 'full loop' case this will test virtually the complete device; if both possible full loops are checked, both complete signal paths are tested. Note that if any external loopback changes the clock domain, the full 'PRBS23' pattern cannot be checked.

FIGURE 6. BLOCK DIAGRAM OF BIST OPERATION

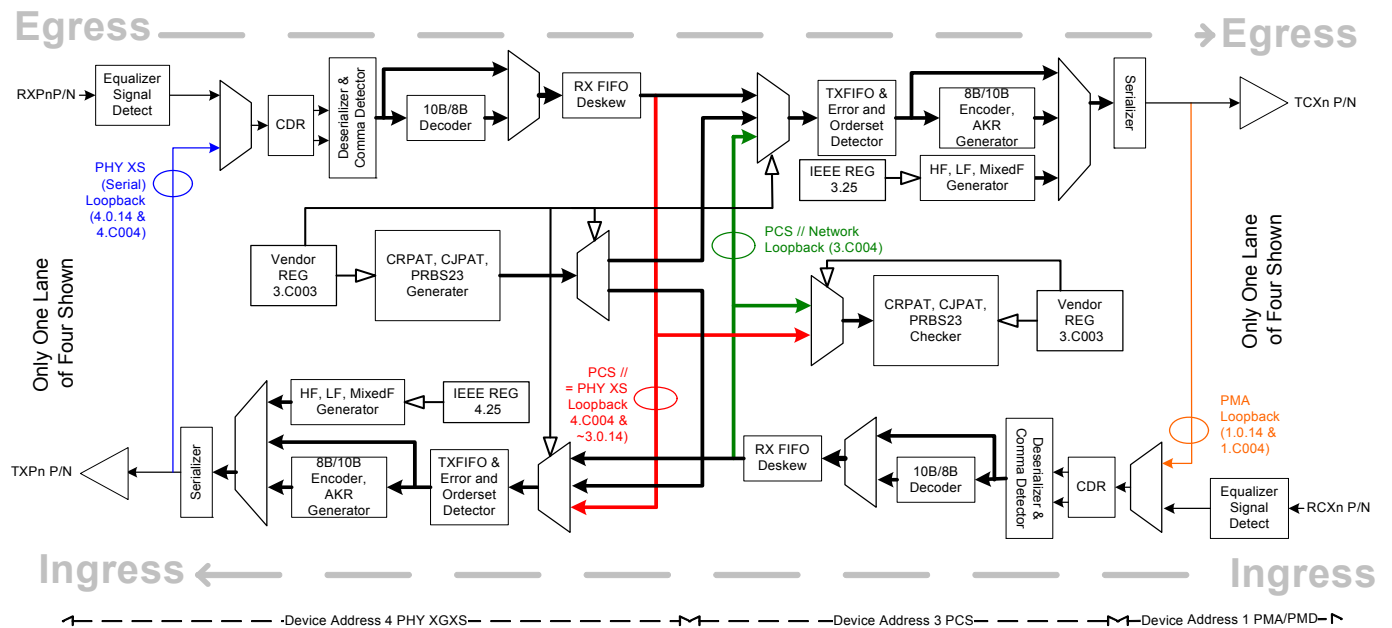

Pin Specifications

Table 94. CLOCK PINS

PIN#	NAME	TYPE	DESCRIPTION
T9/T8	RFCP/RFCN	Input LVPECL	Differential Reference Input Clock. The reference input clock frequency is line rate clock frequency divided by 20 (full rate mode) or 10 (half rate mode). The pins are internally biased at VDDA/2, and should be AC coupled.
C10	TXCLK20	Output 1.5V CMOS	Transmit Clock Output. Divided-by-20 transmit clock output.

Table 95. XAUI (XENPAK/XPAK/X2) SIDE SERIAL DATA PINS

PIN#	NAME	TYPE	DESCRIPTION
T14/T15	TXP0P/TXP0N	Output CML	Transmit Differential Pairs, Lane 0 to 3. CML High speed serial outputs.
P14/P15	TXP1P/TXP1N		
M14/M15	TXP2P/TXP2N		
K14/K15	TXP3P/TXP3N		
H14/H15	RXP0P/RXP0N	Input CML	Receive Differential Pairs, Lane 0 to 3. CML High speed serial inputs. Differentially terminated at 100Ω
F14/F15	RXP1P/RXP1N		
D14/D15	RXP2P/RXP2N		
B14/B15	RXP3P/RXP3N		

Table 96. PMA/PMD (CX4/LX4) SIDE SERIAL DATA PINS

PIN#	NAME	TYPE	DESCRIPTION
A2/A3	TCX0P/TCX0N	Output CML	Transmit Differential Pairs, Lane 0 to 3. CML High speed serial outputs.
C2/C3	TCX1P/TCX1N		
E2/E3	TCX2P/TCX2N		
G2/G3	TCX3P/TCX3N		
R2/R3	RCX0P/RCX0N	Input CML	Receive Differential Pairs, Lane 0 to 3. CML High speed serial inputs. Differentially terminated at 100Ω
N2/N3	RCX1P/RCX1N		
L2/L3	RCX2P/RCX2N		
J2/J3	RCX3P/RCX3N		

Table 97. JTAG INTERFACE PINS

PIN#	NAME	TYPE	DESCRIPTION
D12	TDI	Input (with pullup)	JTAG Input Data. 1.5V CMOS
B12	TDO	Output (open drain)	JTAG Output Data. 1.5V CMOS, 2.5V Tolerant
D8	TMS	Input (with pullup)	JTAG Mode Select. 1.5V CMOS
C12	TCLK	Input (with pulldown)	JTAG Clock. 1.2V CMOS, 2.5V Tolerant, with Schmitt trigger
C8	TRSTN	Input (with pullup)	JTAG Reset. 1.5V CMOS

Table 98. MANAGEMENT DATA INTERFACE PINS

PIN#	NAME	TYPE	DESCRIPTION
P11	MDIO	I/O (open drain output)	Management Address/Data I/O. 1.2V CMOS input, 2.5V Tolerant
R11	MDC	Input	Management Interface Clock. 1.2V CMOS, 2.5V Tolerant, with Schmitt trigger
R12	PADR[4]	Input	Management Port Address Setting 1.2V CMOS
T12	PADR[3]		
P12	PADR[2]		
N12	PADR[1]		
T11	PADR[0]		

Table 99. MISCELLANEOUS PINS

PIN#	NAME	TYPE	DESCRIPTION
N11	MF[0]	Output 1.5V CMOS	Multi-function Outputs, Lanes 0 - 3. The functions of these pins are enabled via the MDIO Interface. The default condition for these pins is PHY XGXS BIST_ERR. See Table 81 (bits MF_SEL and MF_CTRL) for further details.
P10	MF[1]		
B9	MF[2]		
A10	MF[3]		
N10	RSTN	Input	Chip Reset (FIFO Clear) Assert RSTN for at least 10µs from power up. Active low. Schmitt trigger input, 1.2V CMOS, 2.5V tolerant.
D10	BIST_ENA	Input (with pulldown)	Built-In Self Test Enable- Active High. When high, enables internal 2 ²³ -1 byte PRBS test function generator and checker. 1.5V CMOS
A11	LX4_MODE	Input (with pulldown)	CX4/LX4 Mode Select. When high, LX4 mode is selected. When low, CX4 mode is selected. This pin decides the trigger sources of LASI, and the default pre-emphasis and equalization strength of the high speed serial port on the PMA/PMD side. 1.5V CMOS
B11	LASI	Output (open drain)	Link Alarm Status Interrupt Request. When low, pin indicates the existence of an incorrect condition. An external 10-22kΩ pull-up to 1.2V or 1.5V is recommended. 1.2V CMOS, 2.5V tolerant.
D7	OPTXLCB ⁽¹⁾	Input	TX Laser Bias Current. Optical monitoring input. Active level is latched into register bit 1.36868.9 and can be configured to trigger LASI. When this pin is not driven by an external device, it should be pulled inactive (default down). 1.5V CMOS, 2.5V tolerant.
D5	OPTTEMP ⁽¹⁾	Input	Transceiver Temperature. Optical monitoring input. Active level is latched into register bit 1.36868.8 and can be configured to trigger LASI. When this pin is not driven by an external device, it should be pulled inactive (default down). 1.5V CMOS, 2.5V tolerant.
D6	OPTXLOP ⁽¹⁾	Input	TX Laser Output Power. Optical monitoring input. Active level is latched into register bit 1.36868.7 and can be configured to trigger LASI. When this pin is not driven by an external device, it should be pulled inactive (default down). 1.5V CMOS, 2.5V tolerant.
N8	TX_FAULT ⁽²⁾	Input	TX Fault Condition. Transmitter (Egress) external fault input. Active level is latched into register bits 1.10 and 1.36868.6 and can be configured to trigger LASI. When this pin is not driven by an external device, it should be pulled inactive (default down). 1.5V CMOS, 2.5V tolerant.
C5	OPRXOP ⁽¹⁾	Input	Receive Optical Power. Optical monitoring input 4. Active level is latched into register bit 1.36867.5 and can be configured to trigger LASI. When this pin is not driven by an external device, it should be pulled inactive (default down). 1.5V CMOS, 2.5V tolerant.
A6	OPRLOS[3] ⁽¹⁾	Input	Optical Receiver Loss Of Signal. Optical monitoring input 5 – 8. Active (loss) levels are latched into register 1.10 and can be configured to trigger LASI. When these pins are not driven by an external device, they should be pulled inactive (default down). 1.5V CMOS, 2.5V tolerant.
A5	OPRLOS[2] ⁽¹⁾		
A7	OPRLOS[1] ⁽¹⁾		
B7	OPRLOS[0] ⁽¹⁾		
D11	XP_ENA	Input	XENPAK Enable. Enable XENPAK support. Active high. Activates 2-wire serial bus interface. 1.5V CMOS, 2.5V tolerant.

Table 99. MISCELLANEOUS PINS (Continued)

PIN#	NAME	TYPE	DESCRIPTION
D9	TX_ENC ⁽¹⁾	Input	Transmit enable input from XENPAK module input "TX ON/OFF". Controls TX_ENA[3:0]. For normal operation, should be pulled active (default up). 1.2V CMOS
B5	TX_ENA[3] ⁽¹⁾	Output (open drain)	Transmit Laser Driver Enables. They are set active only when TX_ENC pin is active and the corresponding bits in register 1.9 are set low. During RESET stage, these pins are always low. 1.5V CMOS, 2.5V compatible.
B6	TX_ENA[2] ⁽¹⁾		
T5	TX_ENA[1] ⁽¹⁾		
R5	TX_ENA[0] ⁽¹⁾		

Note (1): Active level of these pins is controlled by register 1.49181 (1.C01D'h), see Table 55. If unused, the TX_ENC pin can be tied high, and the register bit not altered. Other unused input pins should be tied low, and the corresponding register bit not altered, so the default value of the register will allow Byte Sync and cause a 'No Fault' indication in the LASI alarm status registers on RESET. See also Table 12, Table 27 and Table 28.

Note (2): Active level of this pin is controlled by register 1.49170 (1.C012'h), see Table 49. Otherwise Note 1 applies.

Table 100. I²C 2-WIRE SERIAL DATA INTERFACE PINS

PIN#	NAME	TYPE	DESCRIPTION
P9	SDA	I/O (open drain)	I²C Serial Address/Data I/O 1.5V CMOS, 2.5V Tolerant and Compatible
P8	SCL	I/O (open drain)	I²C Serial Interface Clock. 1.5V CMOS, 2.5V Tolerant and Compatible
C7	WRTP	Input	I²C Serial Interface Write Protection. When high, no write to protected XENPAK basic NVR area is allowed. 1.5V CMOS, 2.5V Tolerant
R6	GPIO[4]	I/O (open drain)	General Purpose I/O Can be used for optical monitoring and status reporting, and to trigger LASI, or for external control functions. 1.5V CMOS, 2.5V Tolerant and Compatible
P7	GPIO[3]		
N7	GPIO[2]		
N6	GPIO[1]		
P6	GPIO[0]		

Table 101. VOLTAGE SUPPLY PINS

PIN#	NAME	TYPE	DESCRIPTION
C6, C13, H13, J4, N5, N13	VDDPR	Supply	2.5V Protection Voltage Supply. May be same level as VDD if no inputs or outputs go above the VDD level.
A4, A8, A9, A12, A13, B10, N9, P4, P5	VDD	Supply	1.5V Digital and Core Supply
B4, C4, C14, D4, D13, E4, E13, F4, F13, G4, G13, K4, K13, L4, L13, M4, M13, N4, P13, R4, R13, T4, T13	VDDA	Analog Supply	1.5V Analog Supply. Should be decoupled from VDD
R7, T7	VDDAV	Analog Supply	Analog supply for VCO. Should be decoupled from VDDA
R10, T10	VDDAC	Analog Supply	Analog supply for CMU. Should be decoupled from VDDA
A1, A14, A15, A16, B1, B2, B3, B8, B13, B16, C1, C9, C11, C15, C16, D1, D2, D3, D16, E1, E14, E15, E16, F1, F2, F3, F16, G1, G14, G15, G16, H1, H2, H3, H4, H16, J1, J13, J14, J15, J16, K1, K2, K3, K16, L1, L14, L15, L16, M1, M2, M3, M16, N1, N14, N15, N16, P1, P2, P3, P16, R1, R8, R9, R14, R15, R16, T1, T2, T3, T6, T16	GNDA	Ground	Ground. Electrically well grounded. Analog and Digital grounds are tied in the device, but it is recommended that some separation be provided in the PCB planes outside the device, to minimize the coupling between digital signals and the analog sections of the device.

Pin Diagram 17x17mm (16*16 Ball Matrix) 192-pin EBGA-B Package

FIGURE 7. TOP VIEW OF PINOUT

	A	B	C	D	E	F	G	H	J	K	L	M	N	P	R	T	
16	GND	GND	GND	GND	GND	GND	GND	GND	GND	GND	GND	GND	GND	GND	GND	GND	16
15	GND	RXP3 N	GND	RXP2 N	GND	RXP1 N	GND	RXP0 N	GND	TXP3 N	GND	TXP2 N	GND	TXP1 N	GND	TXP0 N	15
14	GND	RXP3 P	VDDA	RXP2 P	GND	RXP1 P	GND	RXP0 P	GND	TXP3 P	GND	TXP2 P	GND	TXP1 P	GND	TXP0 P	14
13	VDD	GND	VDD PR	VDDA	VDDA	VDDA	VDDA	VDD PR	GND	VDDA	VDDA	VDDA	VDD PR	VDDA	VDDA	VDDA	13
12	VDD	TDO	TCLK	TDI									PADR 1	PADR 2	PADR 4	PADR 3	12
11	LX4 MODE	LASI	GND	XP_E NA									MF0	MDIO	MDC	PADR 0	11
10	MF3	VDD	TXCL K20	BIST_ ENA									RSTN	MF1	VDDA C	VDDA C	10
9	VDD	MF2	GND	TX_E NC									VDD	SDA	GND	RFCP	9
8	VDD	GND	TRST N	TMS									TX_F AULT	SCL	GND	RFCN	8
7	OPR LOS1	OPR LOS0	WRTP	OPTX LBC									GPIO 2	GPIO 3	VDDA V	VDDA V	7
6	OPR LOS3	TX_E NA2	VDD PR	OPTX LOP	GPIO 1	GPIO 0	GPIO 4	GND	6								
5	OPR LOS2	TX_E NA3	OPRX OP	OPT TEMP	VDD PR	VDD	TX_E NA0	TX_E NA1	5								
4	VDD	VDDA	VDDA	VDDA	VDDA	VDDA	VDDA	GND	VDD PR	VDDA	VDDA	VDDA	VDDA	VDD	VDDA	VDDA	4
3	TCX0 N	GND	TCX1 N	GND	TCX2 N	GND	TCX3 N	GND	RCX3 N	GND	RCX2 N	GND	RCX1 N	GND	RCX0 N	GND	3
2	TCX0 P	GND	TCX1 P	GND	TCX2 P	GND	TCX3 P	GND	RCX3 P	GND	RCX2 P	GND	RCX1 P	GND	RCX0 P	GND	2
1	GND	GND	GND	GND	GND	GND	GND	GND	GND	GND	GND	GND	GND	GND	GND	GND	1
	A	B	C	D	E	F	G	H	J	K	L	M	N	P	R	T	

Package Dimensions

FIGURE 8. EBGA-192 PACKAGE DIMENSIONS

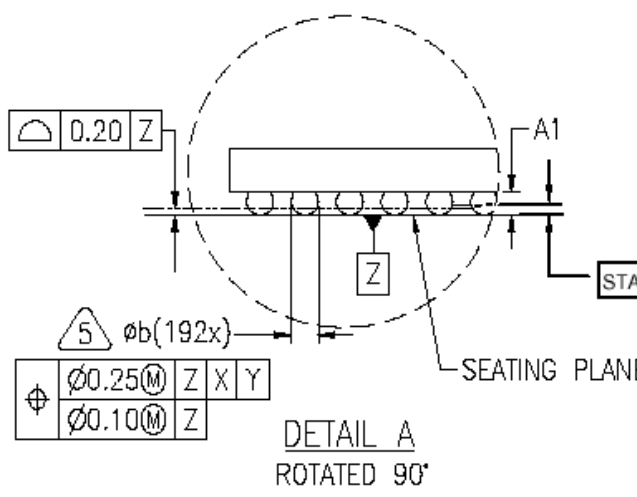
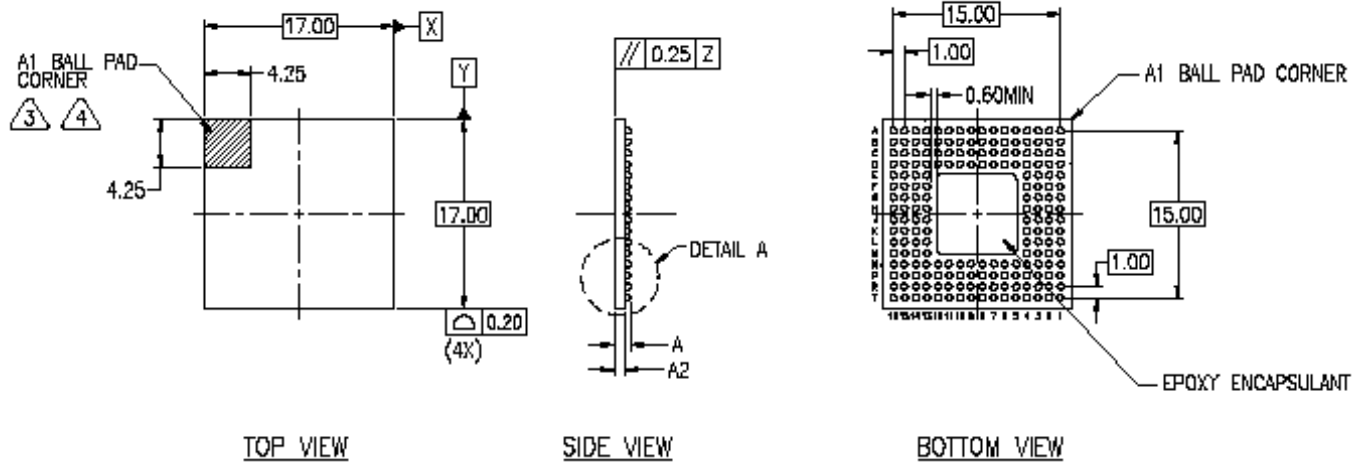

DIMENSION	MINIMUM	NOMINAL	MAXIMUM
A	1.32	1.50	1.70
A1	0.40	0.50	—
A2	0.92	0.99	1.06
b	0.50	0.60	0.70
NUMBER OF BALLS 192			

Electrical Characteristics

Absolute Maximum Ratings

Table 102. ABSOLUTE MAXIMUM RATINGS

SYMBOL	PARAMETER	MIN	MAX	UNITS
V _{DDPR}	2.5V Protection Power Supply Voltage	-0.5, V _{DD} - 0.5	2.6, V _{DD} + 2.0	V
V _{DDA} , V _{DD} , V _{DDAC} , V _{DDAV}	All Other Power Supply Voltages	-0.5	1.65	V
V _{INCML}	CML DC Input Voltage	-0.5	V _{DD} + 0.5	V
I _{OUTCML}	CML Output Current	- 50	+50	mA
V _{INCMS1}	1.2V CMOS Input Voltage	-0.5	V _{DD} + 0.5	V
V _{INCMS2}	1.5V CMOS Input Voltage	-0.5	V _{DD} + 0.5	V
V _{INCMS3}	2.5V Tolerant CMOS Input Voltage	-0.5	2.6	V
T _{stg}	Storage Temperature	- 55	125	°C
T _j	Junction Temperature	- 55	125	°C
T _{SOL}	Soldering Temperature (10s)		220	°C
V _{ESD}	Maximum Input ESD (HBM)	-2000	2000	V

Note (1): These ratings are those which if exceeded may cause permanent damage to the device. Operation at these or any other conditions in excess of those listed under Operating Conditions below is not implied. Continued exposure to these ratings may reduce device reliability.

Operating Conditions

All Standard Device specifications assume T_C = 0°C to +85°C, V_{DDAC} = V_{DDAV} = V_{DD} = V_{DDA} = 1.5V ± 5%, V_{DDPR} = V_{DD} or 2.4V ± 0.1V, unless otherwise specified.

The Low Power Device specifications assume T_C = 0°C to +85°C, V_{DDAC} = V_{DDAV} = V_{DD} = V_{DDA} = 1.355V ± 4%, V_{DDPR} = V_{DD} or 2.4V ± 0.1V, unless otherwise specified.

Table 103. RECOMMENDED OPERATING CONDITIONS

SYMBOL	PARAMETER	MIN	NOM	MAX	UNITS
V _{DDA} , V _{DDAV} , V _{DDAC} & V _{DD}	Core and Serial I/O Power Supply Voltages	(Standard Device) 1.425	1.5	1.575	V
		(Low Power Device) 1.300	1.355	1.410	V
V _{DDPR}	Control I/O Protection Power Supply Voltage	V _{DD}	(1)	2.5	V
T _A	Ambient Operating Temperature ⁽²⁾	0	25	+70	°C
T _C	Case Operating Temperature	0		+85	°C

Note (1): The V_{DDPR} supply should be tied to a level at or above V_{DD}, and at the highest level expected on any "2.5V tolerant" control pin, consistent with the above ratings.

Note (2): For reference only. All testing is performed based on Case Temperature.

Table 104. POWER DISSIPATION AND THERMAL RESISTANCE

SYMBOL	PARAMETER	TYP ⁽¹⁾	MAX ⁽¹⁾	UNITS	
PD	Power Dissipation ⁽²⁾	(Standard Device)	1650	1830	mW
		(Low Power Device)	1350	1475	mW
θ _{JC}	Thermal Resistance, Junction to Case	2.0		°C/W	
θ _{CA}	Thermal Resistance, Case to Ambient (still air, gap filler & cold plate)	13.0		°C/W	
θ _{CA}	Thermal Resistance, Case to Ambient (still air only)	31.0		°C/W	

Note (1): The 'Max' value is at the maximum supply voltages, while the 'Typ' value is at the nominal supply voltages. The power dissipation is not significantly affected by the V_{DDPR} supply (see Table 111 for the distribution of power between the supplies).

Note (2): The operating power varies slightly with the data pattern. The part is tested using a PRBS23 pattern.

DC Characteristics**Table 105. PMA SERIAL PIN I/O ELECTRICAL SPECIFICATIONS, CX4 MODE ⁽³⁾**

SYMBOL	PARAMETER	MIN	TYP	MAX	UNITS
V _{P-PIN}	Peak-To-Peak Differential Voltage Input Requirement ⁽¹⁾	100	>60	2000	mV
V _{P-POUT2}	Peak-To-Peak Differential Voltage Output (Z _O = 100Ω differential load), definition as per IEEE 802.3ak-2004 ⁽²⁾ , Standard Device Only	800	1000	1200	mV
ΔV _{P-POUT2}	Difference between V _{P-POUT2} from Lane to Lane on any group (CX4 or XAUI) ⁽²⁾		75	150	mV
V _{CMO}	Output Common Mode Voltage		V _{DD} -5		V
V _{CMi}	Internal Input Common Mode Voltage		0.4		V

Note (1): Measured at TP3 as defined in the IEEE 802.3ak-2004 specifications. This value is needed in each IPG to maintain the SIG_DET function active. The

BBT3821 will provide a BER < 1 in 10⁻¹² under the conditions of clause 54.6.4.1 of the specification.

Note (2): Measured at TP2 as defined in the IEEE 802.3ak-2004 specifications.

Note (3): CX4 Mode not specified for low power V_{dd} = 1.35V operation; "Standard Device" conditions are required.

Table 106. PMA SERIAL PIN I/O ELECTRICAL SPECIFICATIONS, LX4 MODE

SYMBOL	PARAMETER	UNITS	MIN	TYP	MAX
V _{P-PIN}	Peak-To-Peak Differential Voltage Input Requirement	mV	100	>60	2000
V _{P-POUT2}	Peak-To-Peak Differential Voltage Output (Z _O = 100Ω differential load)	(Standard) mV	800	1100	1600
		(LowPower) ⁽¹⁾ mV	650		
V _{CMO}	Output Common Mode Voltage	V		V _{DD} -5	
V _{CMi}	Internal Input Common Mode Voltage	V		0.4	

Note (1): BBT3821LP-JH only.

Table 107. PHY XS SERIAL PIN I/O ELECTRICAL SPECIFICATIONS, XAUI MODE

SYMBOL	PARAMETER	MIN	TYP	MAX	UNITS
V _{P-PIN}	Peak-To-Peak Differential Voltage Input Requirement	100	>60	2000	mV
V _{P-POUT2}	Peak-To-Peak Differential Voltage Output (Z _O = 100Ω differential load), definition as per 802.3ae-2002	800	1200	1600	mV
V _{CMO}	Output Common Mode Voltage		V _{DD} -6		V
V _{CMi}	Internal Input Common Mode Voltage		0.4		V

Note (1): Measured using CJPAT.

Table 108. EXTERNAL 1.2V CMOS OPEN DRAIN I/O ELECTRICAL SPECIFICATIONS

V_{PULL} = External pullup Voltage, not to exceed V_{DD}

SYMBOL	PARAMETER	MIN	TYP	MAX	UNITS
R _{Pullup}	External pullup resistor for open drain O/P ⁽¹⁾	10		22	kΩ
V _{OL}	Output Low Voltage Level (I _{OL} = 4mA) ⁽²⁾	0	120	200	mV
V _{OH}	Output High Voltage Level ⁽¹⁾	V _{PULL} -0.4		V _{PULL}	V
V _{IL}	Input Low Voltage Level	-0.2		0.360	V
V _{IH}	Input High Voltage Level	0.840		V _{DD} +0.2	V
V _{HYST}	Hysteresis on Schmitt Trigger Inputs ⁽³⁾	100	150		mV
I _{IL}	Input Low Current, V _{IN} = 0.0V	-80			μA
I _{IH}	Input High Current, V _{IN} = V _{DD}		.1	10	μA

Note (1): XENPAK MSA recommended for LASI pin.

Note (2): For MDIO and LASI pins.

Note (3): Only for RSTN and MDC pins.

Table 109. 1.5V CMOS INPUT/OUTPUT ELECTRICAL SPECIFICATIONS

SYMBOL	PARAMETER	MIN	TYP	MAX	UNITS
V _{OL}	Output Low Voltage Level (I _{OL} = 2 mA)	0	200	400	mV
V _{OH}	Open Drain Output High Voltage Level ⁽¹⁾	V _{DD} -0.4		V _{DD}	V
V _{OH}	Output High Voltage Level (I _{OH} = 2mA) ⁽²⁾	V _{DD} -0.4		V _{DD}	V
V _{IL}	Input Low Voltage Level	-0.2		0.3*V _{DD}	V
V _{IH}	Input High Voltage Level	0.7*V _{DD}		V _{DD} +0.2	V
I _{ILPU}	Input Low Current, V _{IN} = 0.0V, with pull-up ⁽³⁾	-100	40		μA
I _{IL}	Input Low Current, V _{IN} = 0.0V	-10	-1		μA
I _{IHPD}	Input High Current, V _{IN} = V _{DD} , w. pull-down ⁽⁴⁾		100	200	μA
I _{IH}	Input High Current, V _{IN} = V _{DD}		1	10	μA

Note (1): Assumes pullup to V_{DD}.

Note (2): For MF[3:0] and TXCLK20 pins only

Note (3): For TDI, TMS, TRSTN pins only

Note (4): For TCLK, BIST_ENA, LX4_MODE pins only

Table 110. 2.5V TOLERANT OPEN DRAIN CMOS INPUT/OUTPUT ELECTRICAL SPECIFICATIONS

V_{PULL} = External pullup Voltage, not to exceed 2.5V or V_{DDPR}

SYMBOL	PARAMETER	MIN	TYP	MAX	UNITS
R _{Pullup}	External pullup resistor for all I/P, open drain O/P	10	15	22	kΩ
V _{OL}	Output Low Voltage Level (I _{OL} = 2mA)	0	200	400	mV
V _{OH}	Output High Voltage Level (I _{OH} = 100μA)	Least of 2.5 & V _{PULL} -0.4	2.5	V _{PULL}	V
V _{IL}	Input Low Voltage Level	-0.2		0.3*V _{DD}	V
V _{IH}	Input High Voltage Level	0.7*V _{DD}		V _{DDPR} +0.2 ⁽¹⁾	V
V _{HYST}	Hysteresis on Schmitt Trigger Inputs ⁽²⁾	100	150		mV
I _{IL}	Input Low Current, V _{IN} = 0.0V	-80			μA
I _{IH}	Input High Current, V _{IN} = 1.5V		.1	10	μA
	Input High Current, V _{IN} = 2.6V or V _{DDPR}			100	μA

Note (1): Input voltage beyond R_{Pullup} pullup resistor; pin should not exceed V_{DDPR} value

Note (2): Only TCK pin.

Table 111. OTHER DC ELECTRICAL SPECIFICATIONS

SYMBOL	PARAMETER	MIN	TYP	MAX	UNITS
I _{DDAV} + I _{DD} + I _{DDA} + I _{DDAC}	Total 1.5V Supply Current, T _A = 25°C		1100		mA
	Total 1.5V Supply Current, T _C = 0 to 85°C ⁽¹⁾			1162 ⁽¹⁾	mA
	Total 1.355V Supply Current, T _C = 0 to 85°C ^(1,2)		1016	1046 ^(1,2)	mA
I _{DDPR}	Protection Voltage Supply Current		0.1	5	mA
I _{DDA}	Analog Supply Current		810		mA
I _{DDAV} · I _{DDAC}	VCO, CMU Supply Current		35		mA
I _{DD}	Digital Core Supply Current		210		mA

Note (1): The Maximum limit is measured using a PRBS23 pattern. The supply current for the CRPAT test pattern is very slightly lower, and for the CJPAT pattern is typically 20mA lower.

Note (2): This Maximum limit refers to the LowPower part only, and is measured at 1.410V.

AC and Timing Characteristics

All specifications assume $T_C = 0^\circ\text{C}$ to $+85^\circ\text{C}$, and $V_{DDAC} = V_{DDAV} = V_{DD} = V_{DDA} = 1.5\text{V} \pm 5\%$ (for the Standard Device) or $V_{DDAC} = V_{DDAV} = V_{DD} = V_{DDA} = 1.35\text{V} \pm 4\%$ (for the Low Power Device), V_{DDPR} between V_{DD} and 2.5V , unless otherwise specified.

Table 112. REFERENCE CLOCK REQUIREMENTS

SYMBOL	PARAMETER	MIN	TYP	MAX	UNITS
F_{REF}	Ref clock frequency range ⁽¹⁾	124.4		159.375	MHz
ΔF_{REF}	Ref clock frequency offset	-100		+100	ppm
T_{REFRF}	Ref clock Rise and Fall Time			1.5	ns
DTC_{REF}	Ref clock duty cycle	45	50	55	%
ΔV_{REF}	Ref Clock Voltage Swing ⁽²⁾	300		1000	mV
V_{CM}	Internal Common Mode Voltage		$V_{DD}/2$		V

Note (1): System requirements are normally much more restrictive, typically ± 100 ppm. This specification refers to the full reference clock frequency range over which the BBT3821 will operate.

Note (2): Single-ended peak-to-peak swing.

Table 113. TRANSMIT SERIAL DIFFERENTIAL OUTPUTS (SEE Figure 9, Figure 10 AND Figure 11)

SYMBOL	PARAMETER	MIN	TYP	MAX	UNIT
	TCXnP/N and TXPxP/N output data rate	2.448		3.1875	Gbps
T_{DR}	Differential Rise time (20%-80%)	60	110	130	ps
T_{DF}	Differential Fall time (20%-80%)	60	110	130	ps
T_{DTOL}	Differential Skew Tolerance		TBD		ps
T_{ODS}	Lane to Lane Differential Skew ⁽²⁾		15		ps
	Differential Output Impedance		100		Ω
	Differential Return Loss (to 2.5GHz)	10			dB
TX_{RJ}	Random Jitter (RMS, 1100 pattern) ⁽¹⁾	2.488Gbps	2	4.5	ps
		3.125Gbps	2.5	4.5	ps
		3.1875	TBD	TBD	ps
	Total Jitter (RMS, PRBS ⁷ pattern)	2.488Gbps		8	ps
		3.125Gbps	6	8	ps
		3.1875		8	ps

Note (1): Strictly the 1100 pattern causes a small additional non-random jitter, so that the true random jitter is slightly less than that shown.

Note (2): Parameter is guaranteed by design

Table 114. RECEIVE SERIAL DIFFERENTIAL INPUT TIMING REQUIREMENTS (SEE Figure 11)

SYMBOL	PARAMETER	MIN	TYP	MAX	UNITS
	RCXnP/N & RXPnP/N Input Data Rate	2.448		3.1875	Gbps
	Input Rate deviation from Reference Clock	-200		+200	ppm
	Bit Synchronization Time			2500	bits
	Frequency Lock after Power-up			2	μs
T_{DTOL}	Input Differential Skew			75	ps
T_{DJ}	Deterministic Jitter ^(1,2)	2.488Gbps	TBD		UI
		3.125Gbps	0.7		UI
		3.1875	TBD		UI
T_{JI}	Total jitter tolerance	2.488Gbps	TBD		UI
		3.125Gbps	0.88		UI
		3.1875	TBD		UI

Note (1): Jitter specifications include all but 10^{-12} of the jitter population.

Note (2): Near end driven by BBT3821 Tx without pre-emphasis.

Table 115. MDIO INTERFACE TIMING (FROM IEEE802.3AE) (SEE Figure 15 TO Figure 17)

SYMBOL	PARAMETER	MIN	TYP	MAX	UNIT
T _{MDCD}	BBT3821 MDIO out delay from MDC	0	5.0	300	ns
T _{MDS}	Setup from MDIO in to MDC	10	1.5		ns
T _{MDH}	Hold from MDC to MDIO in	10	1.5		ns
T _{MDC}	Clock Period MDC ⁽¹⁾	100	400		ns
T _{MDV}	MDC Clock HI or LO time ⁽¹⁾	20	160		ns
T _{Update}	Delay from last data bit to register update ⁽²⁾		2		T _{MDC}
C _{MD}	Input Capacitance			10	pF

Note (1): The BBT3821 will accept a much higher MDC clock rate and shorter HI and LO times than the IEEE802.3 specification (section 22.2.2.11) requires. Such a faster clock may not be acceptable to other devices on the interface.

Note (2): The BBT3821 MDIO registers will not be written until two MDC clocks have occurred after the frame end. These will normally count toward the minimum preamble before the next frame, except in the case of writing a RESET into [1,3,4].0.15, see Figure 17.

Table 116. RESET AND MDIO TIMING (SEE Figure 17)

SYMBOL	PARAMETER	MIN	TYP	MAX	UNITS
T _{RSTBIT}	Reset bit Active width		2		T _{MDC}
T _{MDRST}	Delay from Reset bit to first active preamble count	240	256	282	T _{REFCLK}

Table 117. RESET AND I²C SERIAL INTERFACE TIMING (SEE Figure 18 AND Figure 24)

SYMBOL	PARAMETER	MIN	TYP	MAX	UNITS
T _{RESET}	RSTN Active width	10			μs
T _{WAIT}	Delay from RSTN to I ² C SCL Start		10		ms
T _{TRAIN}	I ² C 'training' (external reset)		30		T _{CLAH_L}
T _{CLAH_L}	Period of I ² C SCL Clock Line (400kHz)	2.5			μs ⁽¹⁾
T _{SCL_DAV}	Setup from I ² C SDA Data Valid to SCL edge	100			ns
T _{SDA_CLV}	Setup, Hold from SDA for START, STOP	600			ns
C _{I2C}	Input Capacitance			10	pF

Note (1): Assuming RFCP-N clock is 156.25MHz, and register bits 1.8005.6:4 set for 400kHz (Table 20). SCL clock period scales with reference clock frequency. Also, per the I²C specification, the SCL 'High' time is stretched by the time taken for SCL to go high after the BBT3821 releases it, to allow an I²C slave to demand additional time. Any RC delays on the SCL line will add to the SCL 'High' time, in increments of approximately 100ns.

Timing Diagrams

FIGURE 9. DIFFERENTIAL OUTPUT SIGNAL TIMING

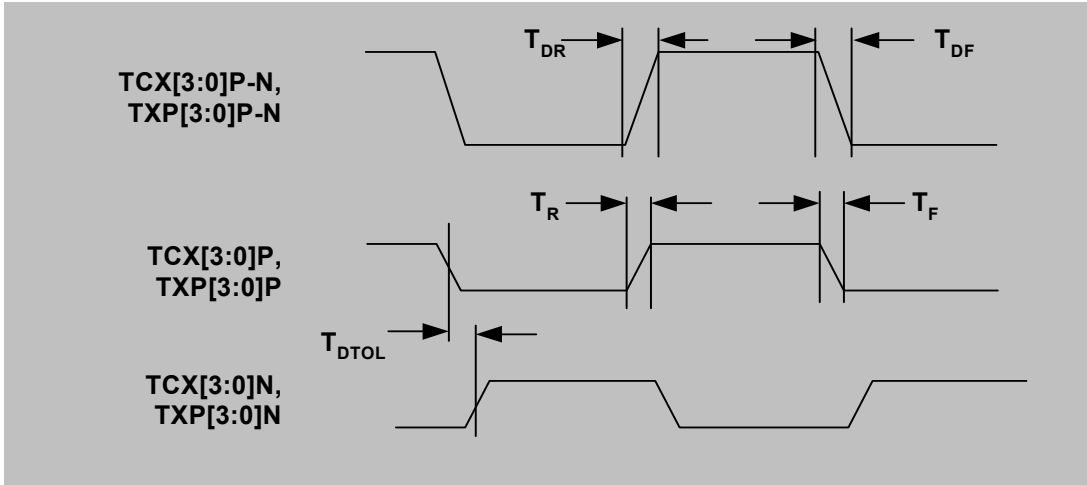

FIGURE 10. LANE TO LANE DIFFERENTIAL SKEW

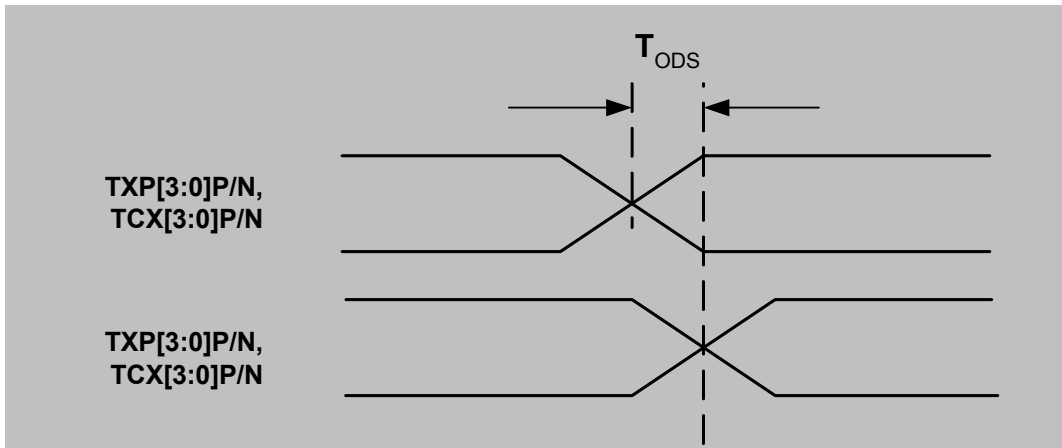

FIGURE 11. EYE DIAGRAM DEFINITION

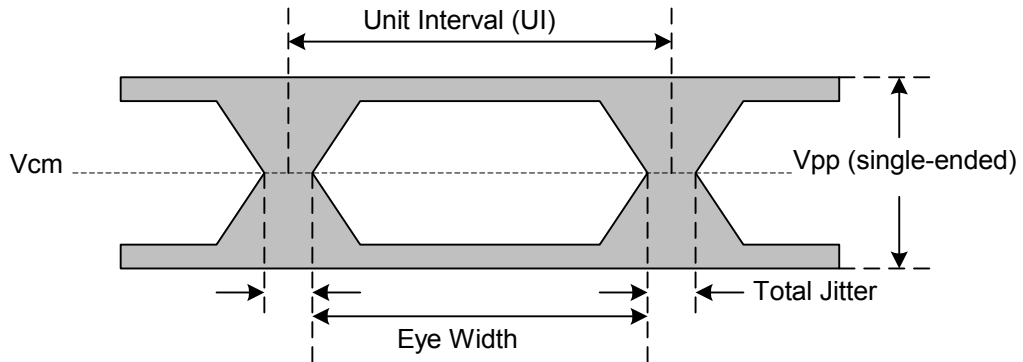

FIGURE 12. BYTE SYNCHRONIZATION

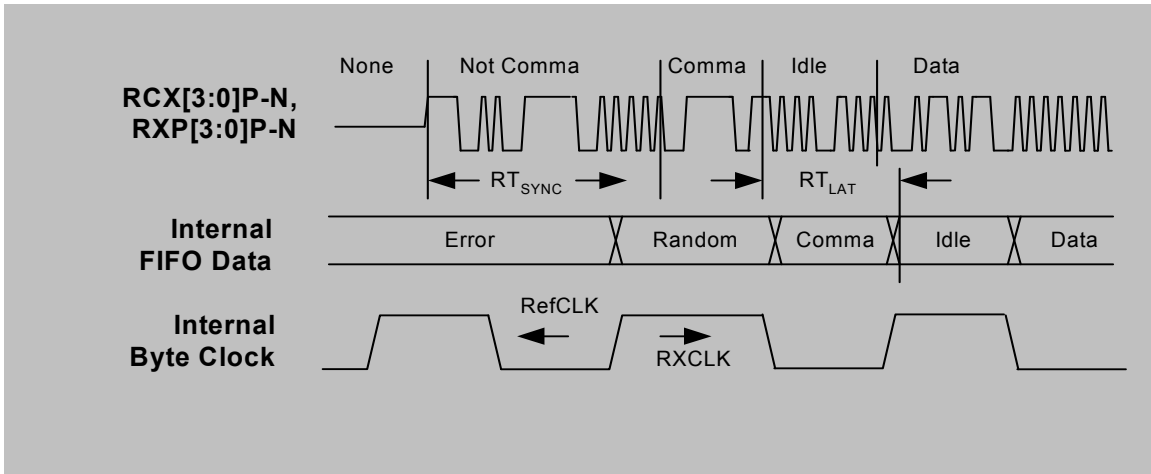

FIGURE 13. LANE-LANE ALIGNMENT OPERATION

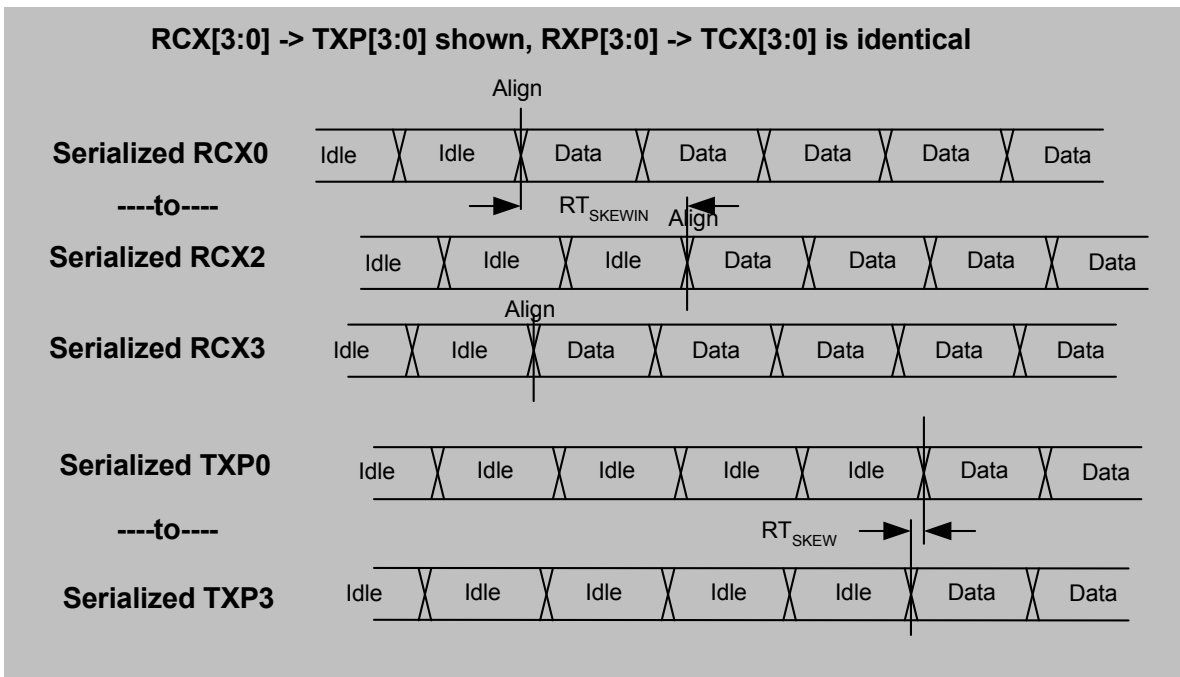

FIGURE 14. RETRANSMIT LATENCY

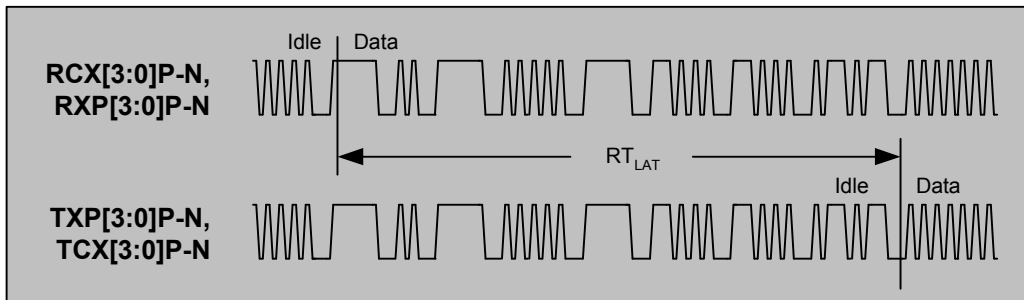

FIGURE 15. MDIO FRAME AND REGISTER TIMING

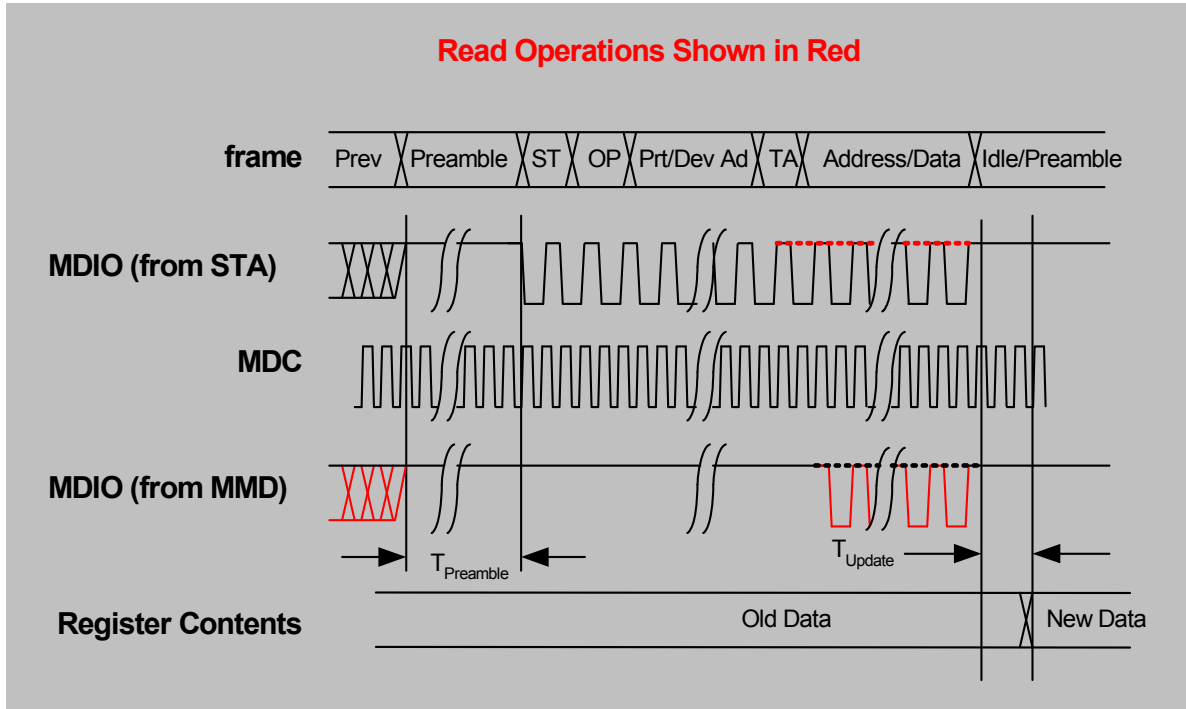

FIGURE 16. MDIO INTERFACE TIMING

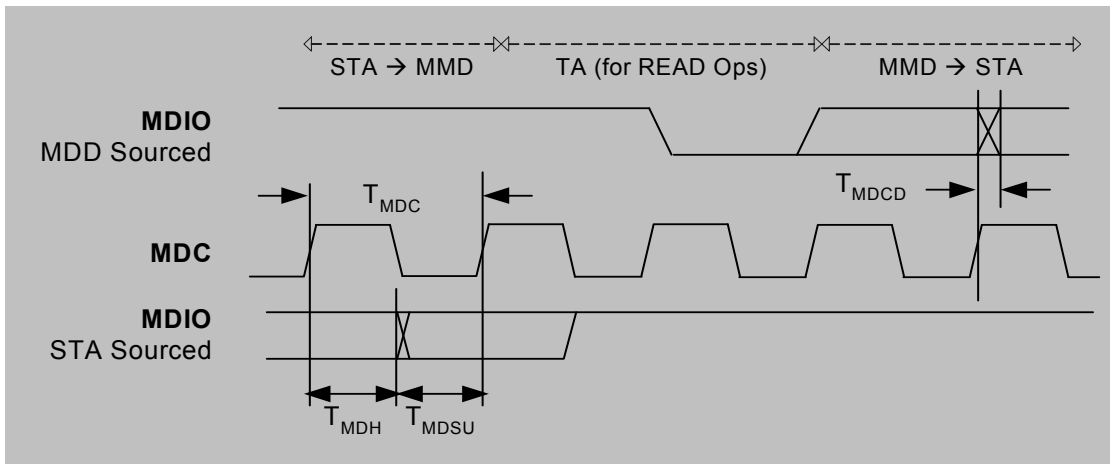

FIGURE 17. MDIO TIMING AFTER SOFT RESET (D.0.15)

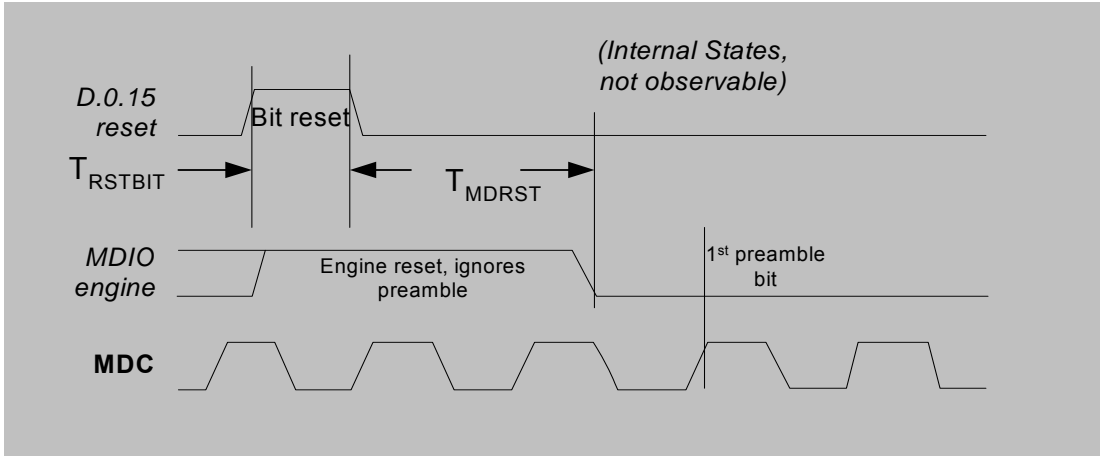

FIGURE 18. BEGINNING I²C NVR READ AT THE END OF RESET

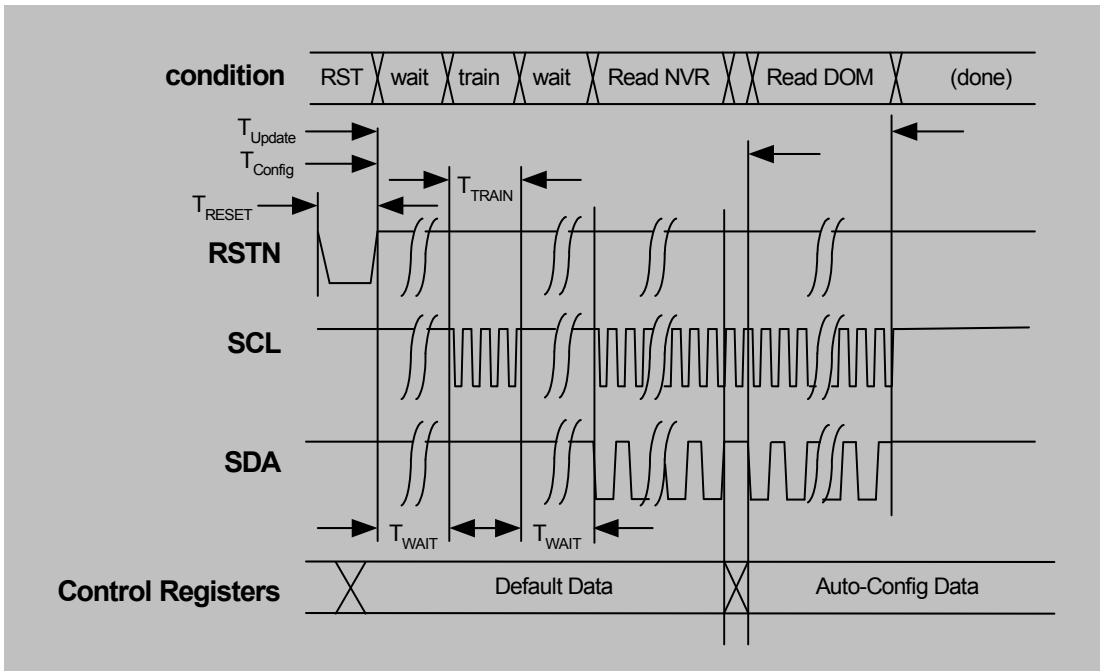

FIGURE 19. I²C BUS INTERFACE PROTOCOL

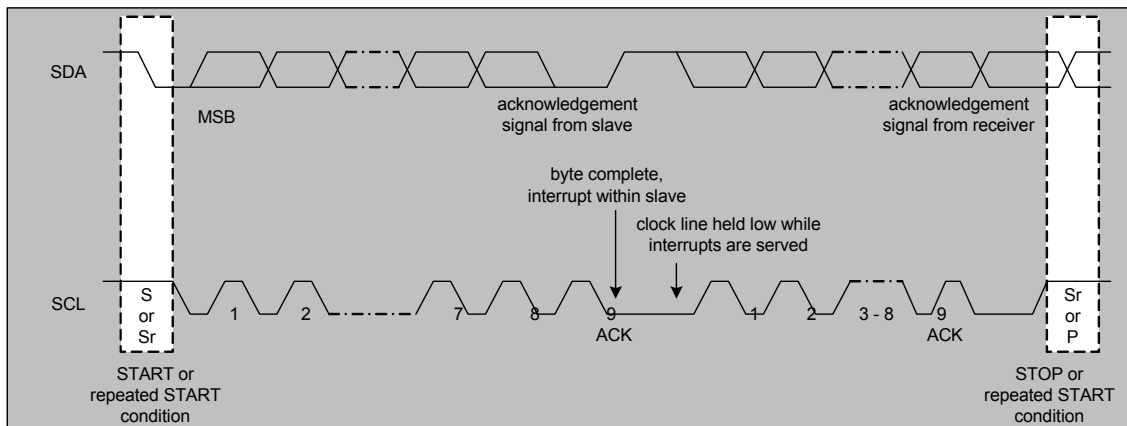

FIGURE 20. NVR/DOM SEQUENTIAL READ OPERATION

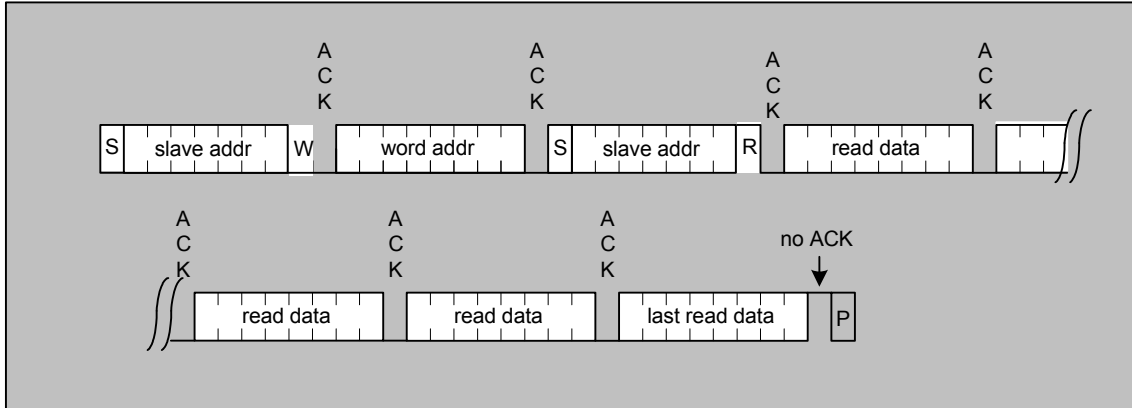

FIGURE 21. NVR SEQUENTIAL WRITE ONE PAGE OPERATION

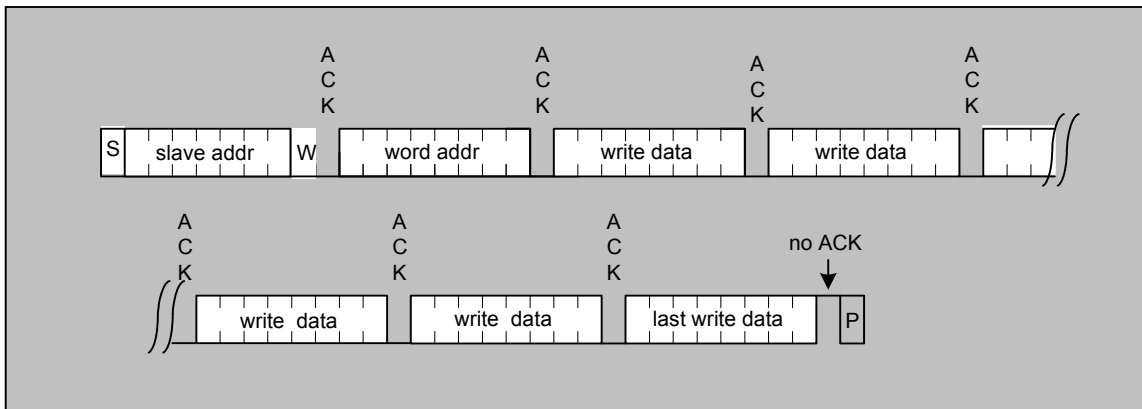

FIGURE 22. I²C SINGLE BYTE READ OPERATION

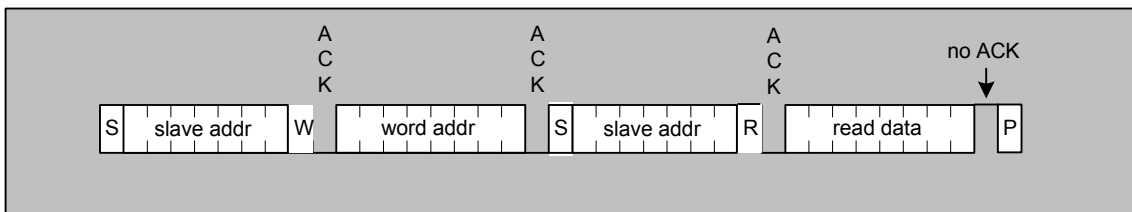

FIGURE 23. SINGLE BYTE WRITE OPERATION

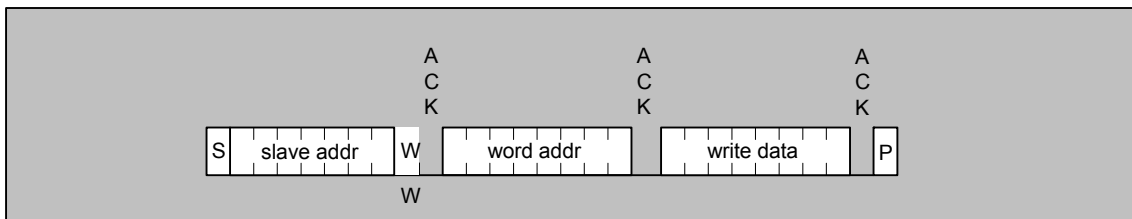
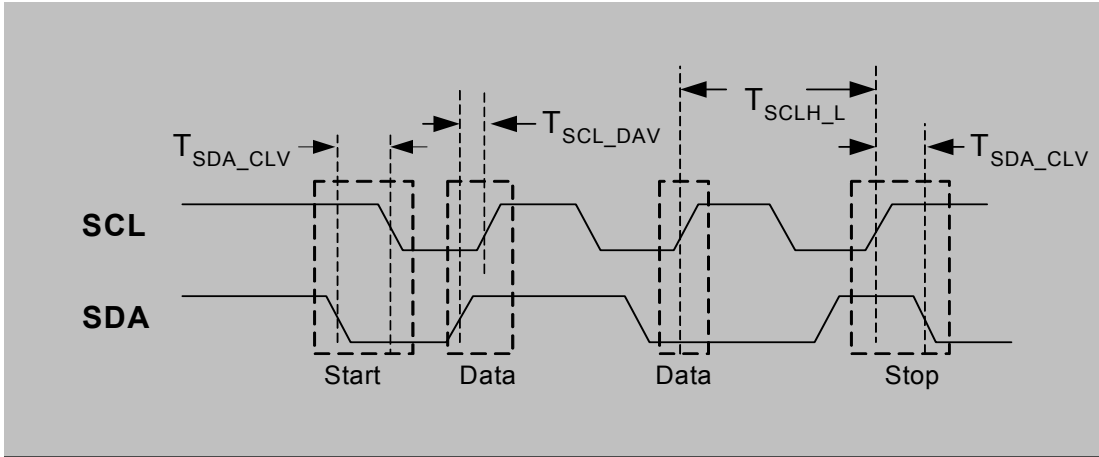

FIGURE 24. I²C OPERATION TIMING

Applications Information

CX4/LX4/XAUI Re-timer Setup

This section discusses the setup for the BBT3821 to be used as a XAUI/CX4/LX4 Retimer. The various descriptions and comments further assume that the device is initially configured in the default condition (i.e. exactly as found after a hardware reset). The BIST_ENA pin should be pulled LOW (to GND); the pin has an internal pulldown to this value. The LX4_MODE select pin should be tied to the appropriate level, depending on whether the BBT3821 is interfaced to a CX4 connection, or a XAUI/LX4 interface (where it is assumed that the electro-optical interface is XAUI-compatible).

Although the BBT3821 will come out of reset with CX4 or XAUI-directed values, some of these default register settings may need to be changed, for optimum operation in any specific application. All of these may be set via the Auto-Configure operation (See “Auto-Configuring Control Registers” on page 16).

The default values of pre-emphasis and receive equalization set by the LX4_MODE select pin may need to be adjusted, particularly if the serial 3Gbps PCB traces on the ‘host’ side (the XAUI or the XENPAK/XPAK/X2 side) are long, (in which case the PHY XS values may need adjustment), or if the connection to a CX4 connector or laser driver and photo detector and limiting amplifier involve extra connectors, long traces, or enhanced edge rates (in which case the PMA/D values should be adjusted).

The default value of the PMA/D and PHY XS XAUI_EN bits is set at ‘1’, and for normal XAUI or CX4/LX4 operation, this is usually the best setting for this use. Byte alignment will follow the IEEE 802.3ae PCS SYNC specification, Lane alignment will follow the DESKEW algorithm in the same specification, and the pseudo-random /A/K/R/ generation in IDLE will also be performed according to the same specifications.

For certain non-10GBASE-X uses, or for debug and problem analysis purposes, and in particular for certain BIST testing, it may be advantageous to change some of the settings. To achieve this, the relevant (PMA/D and/or PHY XS) XAUI_EN bits must be turned off (to ‘0’), since otherwise they will override many of the other registers’ bits (see Table 65). For instance, if it desirable to change Byte Alignment to a simpler algorithm than the IEEE-defined one (if, for example, only three of the four lanes are working), the PCS_SYNC_EN bit(s) (Table 63 and/or Table 80) may be turned off, and (with the respective XAUI_EN bit off), byte (code group) alignment on the working lanes will now function. Similarly, setting the A_ALIGN_DIS bit in the PCS/PHY XS Control Register 2 ([3,4].C000’h) will cause lane alignment to occur on IDLE to non-IDLE transitions across all four lanes, instead of lane alignment on ||A|| (K28.3) character columns when this bit is set to a zero. The internal (pseudo-XGMII) ERROR character can be set to a value other than 1FE’h by writing the value (without the K bit) to register 3.C002’h or 4.C002’h. Similarly, the internal (pseudo-XGMII) IDLE character may be changed using registers 3.C003’h and/or 4.C003’h. The pseudo-random XAUI/CX4/LX4 IDLE /A/K/R/ generator can be disabled by clearing the AKR_SM_EN bit in register 3.C001’h (PCS) or 4.C001’h (PHY XS). To disallow complete regeneration of the Inter Packet Gap (IPG), it would be desirable to clear the TRANS_EN bit in register 3.C001’h/4.C001’h.

Recommended Analog Power and Ground Plane Splits

The BBT3821 high-speed analog circuits as well as high-speed I/O draw power from the analog power (V_{DDA}) and (shared) ground GNDA pins/balls (pins or balls will be used inter-changeably through out this document). In order for the BBT3821 to achieve best performance, the V_{DDA} and GNDA should be kept as “quiet” as possible. There are also

two further analog supplies, V_{DDAC} and V_{DDAV} for the CMU and VCO respectively. These two also need to be kept quiet.

The V_{DDA} , V_{DDAC} , V_{DDAV} and V_{DD} voltage requirements of the standard BBT3821 are all 1.5V (for the Low Power LX4-only version 1.355V). The ripple noise on the $V_{DDA\#}$ voltage rails should be as low as possible for best jitter performance. Therefore, in the layout, each V_{DDA} should be decoupled from the main 1.5V(1.4V) supply by means of cut outs in the power plane, and the power to the individual V_{DDA} areas supplied through ferrite beads (1A capability is recommended). The cut out spacing should be at least 20mil (0.5mm).

A “quiet” analog ground also enhances the jitter performance of the BBT3821 as well. A similar cut out in the ground plane is recommended, to isolate the analog sections from the digital ones.

Recommended Power Supply Decoupling

For the BBT3821, the decoupling for V_{DDA} , V_{DD} , V_{DDAC} , and V_{DDAV} must all be handled individually.

V_{DDA} (1.5V/1.355V) provides power to most of the analog circuits as well as the high speed I/Os. The analog power supply V_{DDA} must have an impedance of less than 0.4Ω from around 50kHz to over 1GHz. This can be achieved by using one 22 μ F (1210 case size, Ceramic), and eleven 0.1 μ F (0402 case size, ceramic), and eleven 0.01 μ F (0402 case size, ceramic) capacitors in parallel. The 0.01 μ F and 0.1 μ F 0402 case size capacitors must be placed right next to the V_{DDA} balls as close as possible. Note that the 22 μ F capacitor must be ceramic for the lowest ESR possible, and must be of 1210 case size or better to achieve this. The 0.01 μ F capacitors should be of case size 0402 or better, offering the lowest ESL to achieve low impedance towards the GHz range. Also, note that the ground of these capacitors must be well connected to GNDA.

Similarly V_{DDAC} and V_{DDAV} (also 1.5V/1.355V) supply the frequency (and hence jitter) determining sections of the BBT3821. They should each be decoupled using one 22 μ F ceramic lowest-ESR-possible capacitor, and one each of 0.01 μ F and 0.1 μ F. The latter especially should be close to the respective balls of the device, with a low impedance trace-path to the device and to GNDA.

The V_{DD} (1.5V/1.355V) supply is the power rail for the BBT3821 core logic circuit. For this supply, at least three 0.1 μ F (0402 case size), three 0.01 μ F (0402 case size) and a 10 μ F (tantalum or ceramic) capacitor are recommended. Place the 0.01 μ F and 0.1 μ F capacitors as close to the V_{DD} balls as possible.

V_{DDPR} (recommended 2.5V or less) is used for certain ESD protection circuits; at least two 0.01 μ F (0402 case size), and two 0.1 μ F (0402 case size) capacitors are recommended. Place the 0.01 μ F and 0.1 μ F capacitors as close to the V_{DDPR} balls as possible. If the V_{DDPR} supply can be

applied faster or earlier than the V_{DD} supply, it is recommended that a limiting clamp be provided to maintain the Absolute Maximum Rating limits of Table 102. A simple example of such a clamp is given in Figure 25, using a small shunt regulator. Since the power dissipation of the regulator is negligible except during the supply power-up time difference, no special heat dissipation precautions are needed.

XENPAK/XPAK/X2 Interfacing

The BBT3821 incorporates a number of features that facilitate interface to the (pin-function-compatible) XENPAK, XPAK and X2 interfaces. The relevant 3.125Gbps serial lines in the BBT3821-JH are brought out in exactly the correct order to be connected to the edge connector, minimizing any layout problems, and the use of vias, in PCB design. Furthermore, the BBT3821 device also incorporates the logic required to handle the TX_ON/OFF and LASI pins, to interface (via an I²C bus) with an EEPROM (or similar device) to load the NVR space with all the MDIO register values specified in the XENPAK MSA R3.0 specification (which are referenced, with only minor OUI-number type changes in the XPAK and X2 specifications), and to transfer Digital Optical Monitoring (DOM) information from typical I²C-interface devices into the XENPAK (etc.) specified MDIO space. If the XP_ENA pin is high at the end of hardware or full MDIO reset, the I²C engine will attempt to read whatever device is on the bus at the A0:00'h address. If it succeeds, it will read the A0:01'h address, and so on, till it reaches A0:FF'h. If at any point the number of I²C Acknowledge (ACK) failures on any address exceeds the limit set in register 1.8005'h (see Table 20) the NVR load will fail, and the result of the operation in 1.8000'h will report the failure.

If a suitable device with 256 bytes at the A0 device address (either a serial EEPROM device like the Atmel AT24C02A or a device such as the Micrel MIC3000 or the Dallas Semiconductor DS1852) is present, the data in it will thus be transferred to the MDIO register space. Most of this data is merely copied to the MDIO space, but a few specific items (listed in Table 22) have additional effects, for example providing the 'Package OUI values for 1.14:15, or the DOM Capability bits in the 1.807A register.

If these DOM Capability bits (listed in Table 23) indicate that the 2-wire bus has a device (again such as the Micrel MIC3000 or the Dallas Semiconductor DS1852) oriented to performing the SFF-8472-defined DOM function, the BBT3821 will attempt to read the data from that device into the MDIO DOM Alarm and Warning Thresholds registers (see Table 32), and the current A/D value and flag registers (see Table 33, Table 36 and Table 37). If the XENPAK DOM Operation Control and Status Register (see Table 38) is set appropriately, the DOM current A/D value and flag registers will be updated periodically from all the DOM device(s), via the DOM device pointers in Table 54 and Table 55. See "I²C Interfacing" below for more details.

CX4 Interfacing

The relevant 3.125Gbps serial lines in the BBT3821-JH are brought out in exactly the correct order to be connected to the CX4 connector, using either the top layer of the PCB for striplines, or an inner layer for microstrip lines, without any necessity for crossing the various leads. There are GNDA pins between each serial line pair, and special care has been taken to facilitate the optimal separation of the TX3 and RX3 line pairs. Increasing the PCB trace separation between these pairs, and adding a strip of GNDA, will decrease the crosstalk effects, which are normally most severe for this pair. Note that the CX4 output will not reliably meet the CX4 specification with the V_{DDA} , V_{DD} , V_{DDAC} , and V_{DDAV} supplies as low as 1.344V (1.4V-4%), so the Low Power version device is not recommended for this usage.

LX4 Interfacing

In LX4 mode, the serial PMA/PMD outputs are by default set up without pre-emphasis, since it is anticipated that the laser driver circuits will be located only a short distance away. This can be overridden by the Auto-configure capability, if desired, to accommodate a lossy or long interconnect, and to provide enhanced high-frequency drive if needed by the laser driver. Similarly, the receiver inputs are set up by default without equalization. Again, this can be overridden by the Auto-configure capability, if desired, to accommodate a lossy or long interconnect, and to compensate for poor high-frequency performance in the photodetectors. Under 'Standard' part conditions, these signals are XAUI-compatible. Under the 'Low Power' supply voltage conditions, the output drive may fall below the XAUI specification. This is normally not a problem for laser drivers, but if Low Power operation is desired, this should be checked.

Many lasers and laser drivers require setting of the laser bias and modulation currents, to optimize the performance. This is frequently done via digitally controlled resistors or current sources, many of which have I²C interfaces for setting the values, often as a function of temperature. By ensuring that the Device Addresses of these circuits are distinct from those of the NVR, and any separate DOM circuits provided, the I²C interface of the BBT3821 can be used to initialize the setups of these circuits. The technique described under "Byte Writes to EEPROM space" on page 19 can always be used in this case. This can be done after a module is fully assembled, if necessary using one of the 'spare' pins on the XENPAK connector, or a GPIO pin, to enable writing to the relevant circuits.

MDIO/MDC Interfacing

The MDIO and MDC lines in the BBT3821 have been designed to maximize compatibility both with older systems, that may use logic levels compatible with 3.3V CMOS designs (such as specified in IEEE 802.3-2002 Clause 22), and newer systems compatible with the levels specified in the 10GE specification IEEE 802.3ae-2002 (based on 1.2V

supplies), and systems using intermediate supply voltages. In general, no problems should occur in any such applications, provided the resistive pull-ups go to no higher than a nominal 2.6V. However, the BBT3821 is inherently a very high-speed device, and the falling-edge-rates generated by the part can be quite high. To avoid problems with excessive coupling between the MDIO line and the MDC line, and consequent generation of false clock-edges on the MDC line, and hence incorrect MDIO operation, the MDC line has been given a Schmitt trigger input.

Note that the MDIO registers will not be written till AFTER up to three additional clocks after the end of a WRITE frame (see Figure 15). It is recommended that MDC run continuously, but if this is not possible, extra clocks should be added after a WRITE. These will count toward the preamble for the next frame (except when the byte written caused a Soft Reset, see Figure 17, and extra preambles may be required).

I²C Interfacing

The I²C interface, normally used to provide the NVR requirements for XENPAK/XPAK/X2 MSA modules, consists of two lines, SCL and SDA. These conform to the I²C specification ('THE I²C-BUS SPECIFICATION, Version 2.1', at URL <http://www.semiconductors.philips.com/acrobat/literature/9398/39340011.pdf>) for Standard-mode (to 100kHz) and Fast-mode (to 400kHz) operation. The BBT3821 is a bus master, and expects to see the NVR EEPROM and/or DOM circuits as slaves. Particularly if Fast-mode operation is desired, the capacitance of and coupling between the SCL and SDA lines should be minimized. Since these lines are 'open drain', the rise time of the SCL line will inherently stretch the 'low' time of the line, as seen by the BBT3821, due to the effect of the RC time constant of the pull-up resistor and the line capacitance. This will slow down the operation of the interface. If the other I²C devices on this bus are 3.3V devices, their V_{IH} levels should be checked to ensure satisfactory logic operation if the pull-up resistors are taken to a nominal 2.5V. If they will work from a lower voltage, the resistors can be taken to any such voltage down to the VDD level. The above reference includes charts for the values of the resistors, based on the capacitance of the line, and the desired clock rate. For the default operation speed of nominally 100kHz, a value of 5k Ω to 15k Ω will normally be suitable, while for Fast-mode operation, 2k Ω to 4k Ω will normally be needed. If a 2.5V supply is not available, resistive dividers may be used to ensure that the signals on the BBT3821 lines do not exceed that level. Some examples are shown in Figure .

DOM Interfacing

The NVR interface has already been discussed above ("XENPAK/XPAK/X2 Interfacing" on page 71). The BBT3821 also includes a flexible DOM interface. See "DOM Registers" on page 16 for details. Most laser drivers and receivers

(TOSA and ROSA) include monitor outputs reflecting the Laser Bias Current, the Laser Output Power, and/or Received Optical Power. Some of these analog outputs are referenced to GND, others to an appropriate V_{DD} . For use in the optional DOM system, these values need to be converted to digital values, compared with alarm and warning levels, and made available as both digital values and as flag registers and alarm signals.

Since the WDM 4-lane DOM interface ideally needs to find 'furthest-out-of-range' values, it will operate most effectively using a single DOM control and conversion device. Suitable parts include the Cygnal C8051F311 device, which can handle the 12 monitored values, 4 V_{DD} signal reference levels, the SCL and SDA signals, and the LASI-driving TX_FAULT, OPTTEMP, OPTXLCB, OPTXLOP, and OPRXOP signals. The device includes a 10-bit differential ADC, a temperature sensor, an onboard clock oscillator, and an I²C bus controller (called the SMBUS system by Cygnal), which should be set up as a slave. The NVR information can all be stored in the on-board Flash EEPROM memory, making for a single NVR/DOM/LASI device. If additional I/O signals are required, the similar C8051F310 has them available, for an increase in board area. Alternatively, an analog multiplexer such as the Maxim MAX4694 could be used to switch inputs between different lanes, under I/O pin control. A similar series of parts are available from Cyex as the SLC series. These parts also include DACs for Laser control functions. If this type of device is used, the BBT3821 should be set up in 'Direct DOM' mode (see Table 51 and "DOM Registers"), and it will then be able to download the complete DOM block as required.

An alternative is to use a device specifically designed as a DOM device, such as the Micrel MIC3000 or the Maxim/Dallas Semiconductor DS1852. Each of these is a single lane device, and is oriented to fulfilling the requirements for SFP modules and the SFF-8472 specification. Although very similar, the latter has some small differences from the XENPAK DOM specification, which can cause problems. If a single device is used, it can be configured as a single DOM device, typically at device address A2, and used to monitor, for example, the average (sum) of the desired values. The thresholds, monitored values, and alarm and warning flags will conform to the required behavior for single-lane monitoring (see Note 2 to Table 27 in section 11.2.6 of the XENPAK R3.0 specification). If the BBT3821 is set up in 'Direct DOM' mode (see Table 51 and "DOM Registers"), the single-lane values will be transferred to the MDIO register space. Such an arrangement may be very suitable for use in a CX4 module, where it could be desirable to measure the temperature, although the "Laser Bias Current", "Received Optical Power", etc. have no meaning (and "Digital Optical Monitoring" is a misnomer!). Note that the DS1852 does not provide a sufficient NVR block for XENPAK, and an

additional 256-byte EEPROM such as an Atmel AT24C02A will be needed.

Using four of the single-lane devices mentioned previously, the system can monitor all four lanes. A first download of a single device would load the full 256-byte space, and the BBT3821 should then be set in 'Indirect Mode' (see Table 51 and "DOM Registers"), with the pointers appropriately reset. For the MIC3000, three of the four devices should have their 'I²CADR' values changed (e.g. to B2, C2 & D2), leaving the fourth at the default DOM address A2. The NVR space will be provided by the A0 space in that last device, while the DOM spaces for each of the four lanes are accessed via the indirect Device Address pointers in 1.C01B:C'h, which would be set to A2, B2, C2 & D2 in the above scenario. The memory address values in 1.C019:A'h would be left at the default 60'h value. To utilize the DS1852, an EEPROM is needed for the NVR at the A0 address space, and one lane's DS1852 should have the D0h Device Address value at the A2 default value, and its ASEL pin should be high. The others (also with ASEL high) should have the D0h values set to an array of different Device Address values, for instance B2, C2 & D2 (as in the previous example), or A4, A6 & A8, and the same values also set in 1.C01B:C'h. A first pass will read the EEPROM space in A2.00:5F'h from the DS1852 device at A2, followed by the A/D and flag values from A2.60:75'h, and various other values to A2.7F'h. The space from A2.80:FF'h depends on the DS1852 Table select byte (7F'h); if this is 0, the source data is empty; if it is set for Table 03, the actual Alarm and Warning threshold values will be returned; if 01 or 02, the various EEPROM banks, depending on the Access Level set. See the DS1852 data sheet for details. Subsequent DOM reads performed with Indirect Access can load the standard XENPAK 4-lane A/D space from the four DOM devices.

Open drain outputs from the DOM devices can be pulled up via resistors to V_{DD} , or any voltage between that and a nominal 2.5V. If a 2.5V supply is not available, resistive dividers may be used to ensure that the signals on the BBT3821 lines do not exceed that level. Active pullup devices should have their outputs divided before reaching the BBT3821 pins. Some examples of each are shown in Figure .

LASI Interface

The BBT3821 incorporates all the logic needed to control and enable the full XENPAK/X2/XPAK Link Alarm Status Interrupt (LASI) system, with several optional incorporated enhancements. Many of the (specified and optional extra) inputs are derived from the status registers in the BBT3821 (See "LASI Registers & I/O" on page 17, and Figure 5), and the others are derived from a set of input pins (see Table 99) that would normally be driven by the corresponding status outputs of the either the TOSA and ROSA devices, or (if implemented) the DOM devices. The active polarity of these pins can be controlled via the BBT3821 registers. Since

many TOSA, ROSA and lane-oriented DOM devices have open-drain outputs that go high on an alarm condition, wire-AND-ing these together for a four-lane indication is not possible (any 'working' lane masks the 'alarmed' lane(s)), some external gating may be required (typically a 4-input OR or NOR gate per alarm). Note that the default polarity of these alarm inputs (active high) will be set after power-up, RESET or a hard (D.0.15) software reset, until the device is reconfigured. If a host-driven configuration is being used, the polarities (controlled by 1.C01D, Table 55) should be set before the LASI enables (1.9002, Table 27). If the Auto-Configure system is used (See "Auto-Configuring Control Registers" on page 16 and Table 92), the configuration may take typically about 100 msec (see Figure 18 and Table 117), and there will normally be a brief interval during which the LASI interrupt is likely to be (incorrectly) activated. LASI host operations would probably normally ignore such 'glitches', since the Byte Synch and Lane Alignment will initially be in 'Fault' condition after such a RESET (per the IEEE 802.3ae specification), and so the relevant latched Local Fault indications will need to be cleared before LASI is meaningful, but it could be advisable to ensure that the additional indications are ignored or cleared in the same way before the full LASI system is activated.

FIGURE 25. V_{DDPR} CLAMP CIRCUIT

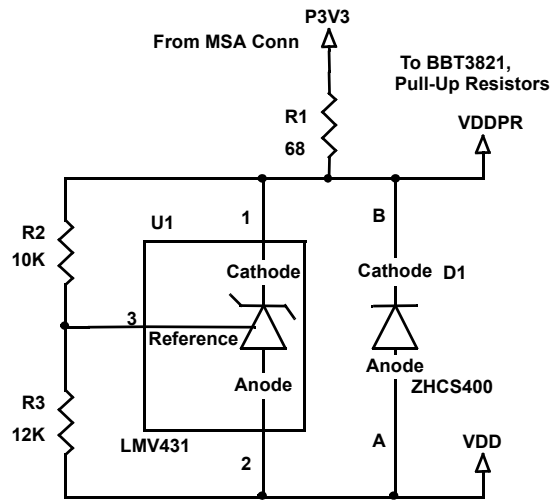
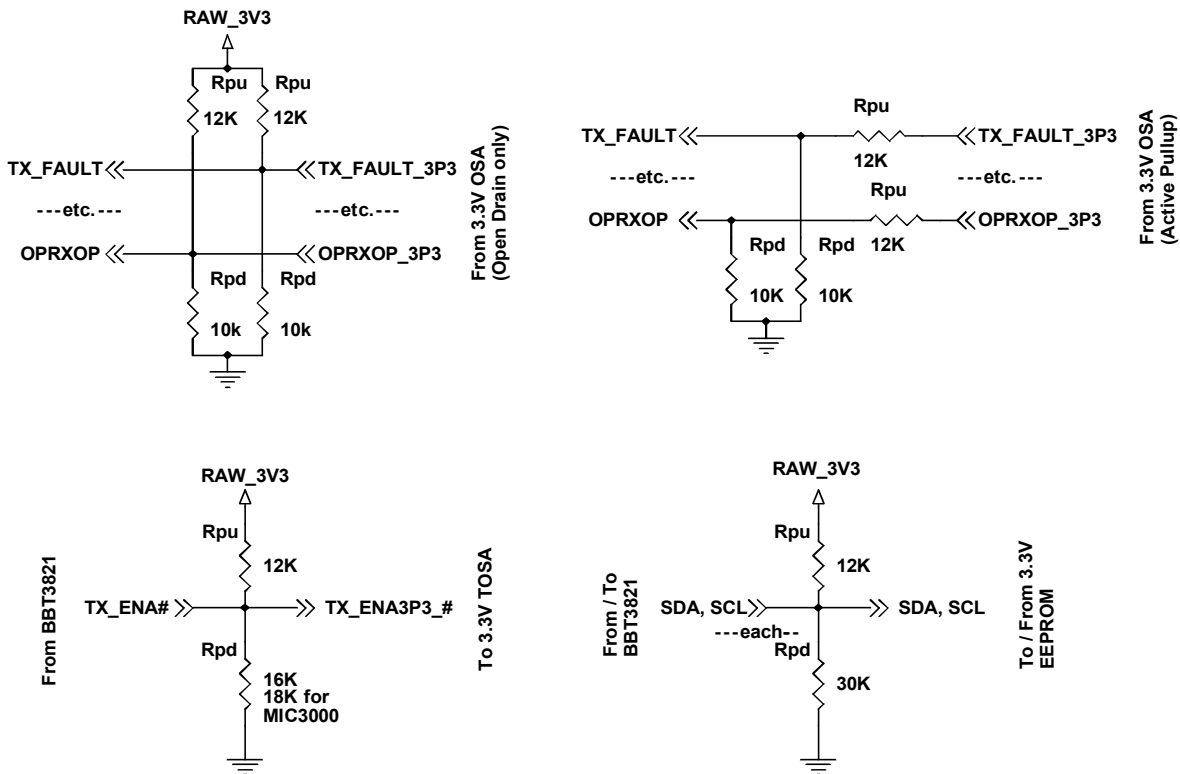

FIGURE 26. RESISTIVE DIVIDER CIRCUITS



Ordering Information

PRODUCT	FREQUENCY	PACKAGE	ORDER PART NUMBER
BBT3821	2.488Gbps- 3.1875Gbps	192 Ld EBGA-B package; 17x17mm	BBT3821-JH
BBT3821 Low Power	2.488Gbps- 3.1875Gbps		BBT3821LP-JH

Intersil Corporation Contact Information

Technical information can be found via the Web page at
<http://www.intersil.com/design/>

Contact Intersil Technical Support by phone at
 1-888-INTERSIL or 1-888-468-3774.

© Copyright Intersil Americas LLC 2005. All Rights Reserved.

All trademarks and registered trademarks are the property of their respective owners.

For additional products, see www.intersil.com/en/products.html

Intersil products are manufactured, assembled and tested utilizing ISO9001 quality systems as noted
 in the quality certifications found at www.intersil.com/en/support/qualandreliability.html

Intersil products are sold by description only. Intersil may modify the circuit design and/or specifications of products at any time without notice, provided that such modification does not, in Intersil's sole judgment, affect the form, fit or function of the product. Accordingly, the reader is cautioned to verify that datasheets are current before placing orders. Information furnished by Intersil is believed to be accurate and reliable. However, no responsibility is assumed by Intersil or its subsidiaries for its use; nor for any infringements of patents or other rights of third parties which may result from its use. No license is granted by implication or otherwise under any patent or patent rights of Intersil or its subsidiaries.

For information regarding Intersil Corporation and its products, see www.intersil.com

Looking for pricing, stock, or lifecycle information?

Click below to explore more details on WIN SOURCE:

 [View BBT3821-JH on WIN SOURCE](#)

 [Intersil Information](#)

Optimize Your Supply Chain with WIN SOURCE Solutions

-  Global Sourcing Solution
-  Obsolete Management
-  Cost Control Management
-  Shortage Management
-  Alternative Solution
-  Excess Inventory Management