

NEW

0.4 mm Pitch, Horizontal mating, Board- to-Fine Coaxial Cable Connectors

DF49 Series

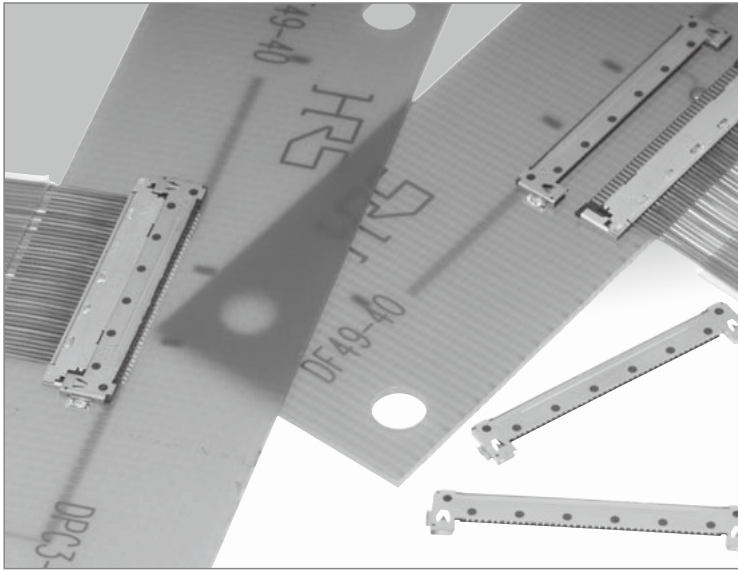

■ Features

1. Ultra low-profile structure

A low-profile and space-saving item, with a stacking height of 0.7mm (0.8mm MAX).

2. Reliable electrical and mechanical connection

Despite its small mated height, unique contact configuration assures highly reliable connection, with effective mating length of 0.5mm.

3. Enhanced shielding and ground connections

Metal shells on the plug and receptacle connect to each other, assuring reliable ground connection and EMC protection.

4. Simplified lock structure with audible click

Audibly clicks into place thanks to the two-point lateral lock structure and optimized contact force.

5. Incorrect insertion prevention mechanism

The bend structure of the shell prevents the reverse insertion of the plug connector and mating failure.

6. Solder wicking prevention

Nickel barriers prevent solder wicking in the critical contact areas. (Receptacle)

■ Connectors for conductivity tests

We have a line-up of plug connectors for inspection, usable for electrical testing.

Reliable connection

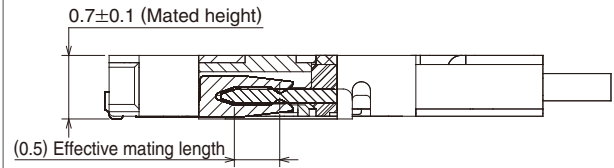

Figure. 1

Mis-insertion Prevention

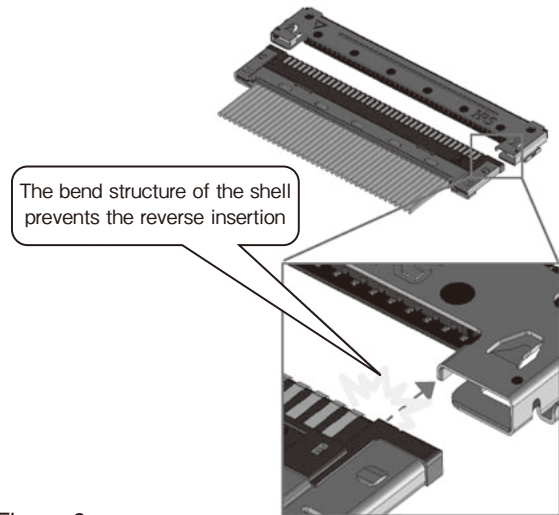

Figure. 2

■ Specifications

Ratings	Current rating	電線サイズ AWG42 : 0.25A AWG44 : 0.2A (Note 3) AWG46 : 0.15A	Operating temperature range -35°C to 85°C (Note 1) Operating humidity range 20% to 80%
	Voltage rating	AC30V	Storage temperature range -10°C to 60°C (Note 2) Storage humidity range 40% to 70% (Note 2)

Item	Specification	Conditions
1. Insulation resistance	50 MΩ min.	100 V DC
2. Withstanding voltage	No flashover or insulation breakdown	100 Vrms AC / 1 minute
3. Contact resistance	Signal:80mΩ max, Ground 80mΩ max	100 mA,(DC or 1,000Hz)
4. Vibration	No electrical discontinuity of 1 μs or longer	Frequency: 10 to 55 Hz, single amplitude of 0.75mm, 10 cycles in each of the 3 directions
5. Humidity	Contact resistance (change from initial value) 50 mΩ max. Insulation resistance: 25 MΩ min.	96 hours at of 40 ±2°C, and humidity of 90 to 95%
6. Temperature cycle	Contact resistance (change from initial value) 50 mΩ max. Insulation resistance: 25 MΩ min.	-55°C → 5 to 35°C → 85°C → 5 to 35°C Time: 30 min. → 2 to 3 min. → 30 min. → 2 to 3 min. 5 cycles
7. Durability	Contact resistance (change from initial value) 50 mΩ max.	30 cycles
8. Resistance to soldering heat	No deformation of affecting performance	Reflow: At the recommended temperature profile Manual soldering: 350°C for 3 seconds

Note 1: Includes temperature rise caused by current flow.

Note 2: The term "storage" refers to products stored for a long period prior to mounting and use.

The operating temperature and humidity range covers the non-conducting condition of installed connectors in storage, shipment or during transportation after board mounting.

Note 3: With only the connector portion at an elevated temperature level, the rated current value is set.

Note 4: Information contained in this catalog represents general requirements for this Series.

Contact us for the drawings and specifications for a specific part number shown.

■ Materials

Product	Part	Material	Finish	Remarks
Receptacle	Insulator	LCP	Color:Black	UL94V-0
	Contacts	Phosphor bronze	Gold plated	—
	Metal fittings	Phosphor bronze	Tin plated	—
Plug	Insulator	LCP	Color:Black	—
	Contacts	Phosphor bronze	Gold plated	UL94V-0
	Metal cover	Phosphor bronze	Tin plated	—
Shell	Metal cover	Phosphor bronze	Tin plated	—

■ Ordering information

● Connector

DF 49 J - * S - 0.4 H ()**

① ② ③ ④ ⑤ ⑥ ⑦ ⑧

DF 49 - * P - SHL

① ② ④ ⑤ ⑨

① Series name:DF	⑥ Contact pitch:0.4mm
② Series No. :49	
③ Connector style Receptacle/Shell J:Receptacle for conductivity tests Blank:Standard	⑦ Termination type H :Rightangle SMT SD:Fine coaxial cable plug
④ Number of positions: 20,30,40	⑧ Packaging (51):Embossed tape packaging
⑤ Connector type S:Receptacle P:Plug	⑨ Installation item(separate) SHL:Metal cover

■ Combinations

[Standard use]

DF49-*S-0.4H(**) + DF49-*P-ASSY
 [DF49-*P-0.4SD(**)
 DF49-*P-SHL]

Note: The product specification of the above combination is shown on page 2.

[Receptacle conductivity test]

DF49-*S-0.4H(**) + DF49J-*P-ASSY·(Note)
 [DF49J-*P-0.4SD(**)
 DF49-*P-SHL]

Note: This harness item is only usable for the receptacle test.

For the product specification of the above combination, please contact our sales department.

[Plug conductivity test]

DF49-*S-0.4H(**) + DF49-*P-ASSY
 [DF49-*P-0.4SD(**)
 DF49-*P-SHL]

Note: For the product specification, please contact our sales department.

※ : ASSY means a harness item.

DF49 Series 0.4 mm Pitch, Horizontal mating, Board- to-Fine Coaxial Cable Connectors

Receptacles (SMT)

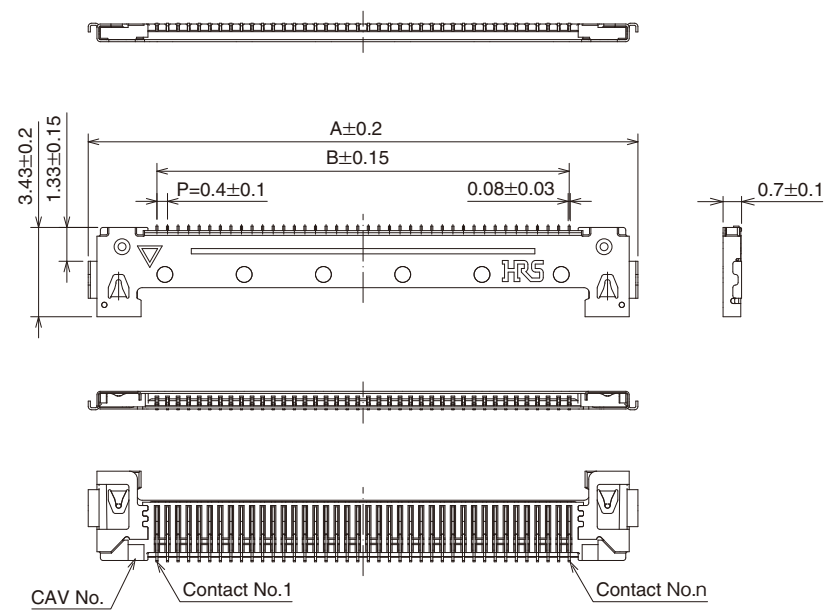
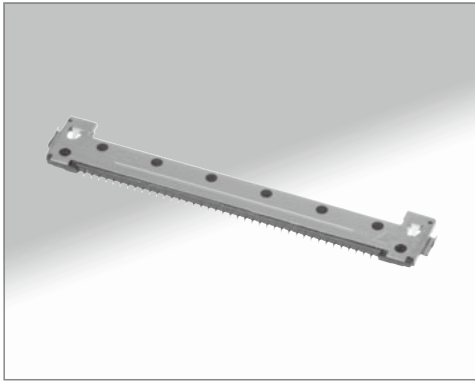

Recommended PCB mounting pattern

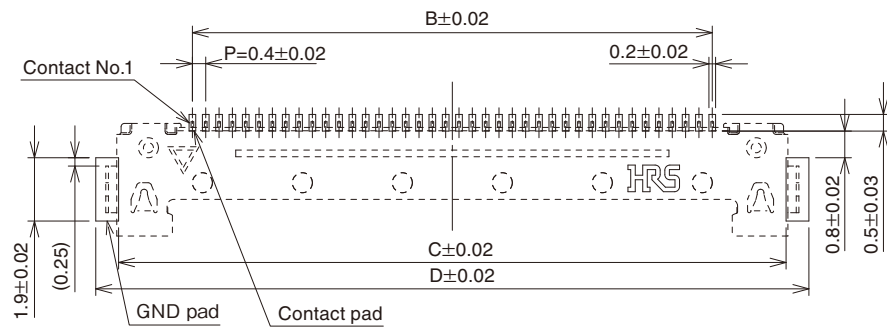

[Specification number] - **, (**)
 (51): Embossed tape packaging
 (7,000 pieces per reel)

Unit : mm

Part Number	CL No.	Number of contacts	A	B	C
DF49-20S-0.4H(**)	662-5503-4-**-	20	12.8	7.6	12.03
DF49-30S-0.4H(**)	Under planning	30	16.8	11.6	16.03
DF49-40S-0.4H(**)	662-5500-6-**-	40	20.8	15.6	20.03

Note 1: Tape and reel packaging (7,000 pieces/reel).
 Order by number of reels.

Plugs

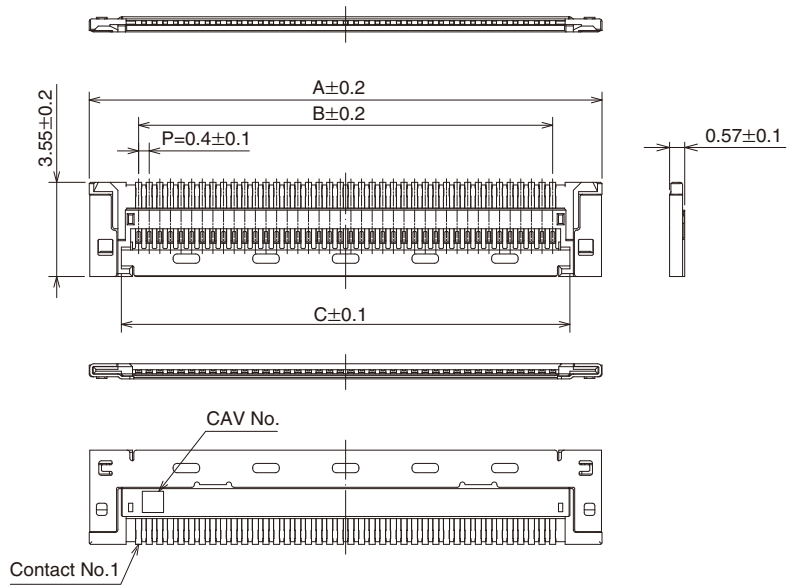

[Specification number] - **, (**)
 (51): Embossed tape packaging
 (7,000 pieces per reel)

Unit : mm

Part Number	CL No.	Number of contacts	A	B	C	D
DF49-20P-0.4SD(**)	662-5504-7-***	20	11.32	7.6	8.9	8.7
DF49-30P-0.4SD(**)	Under planning	30	15.32	11.6	12.9	12.7
DF49-40P-0.4SD(**)	662-5501-9-***	40	19.32	15.6	16.9	16.7

Note 1: Tape and reel packaging (7,000 pieces/reel).

Order by number of reels.

Note 2: The metal cover (DF49-*P-SHL) is required for fine coaxial cable termination.

Recommended Fine Coaxial Cable Preparation

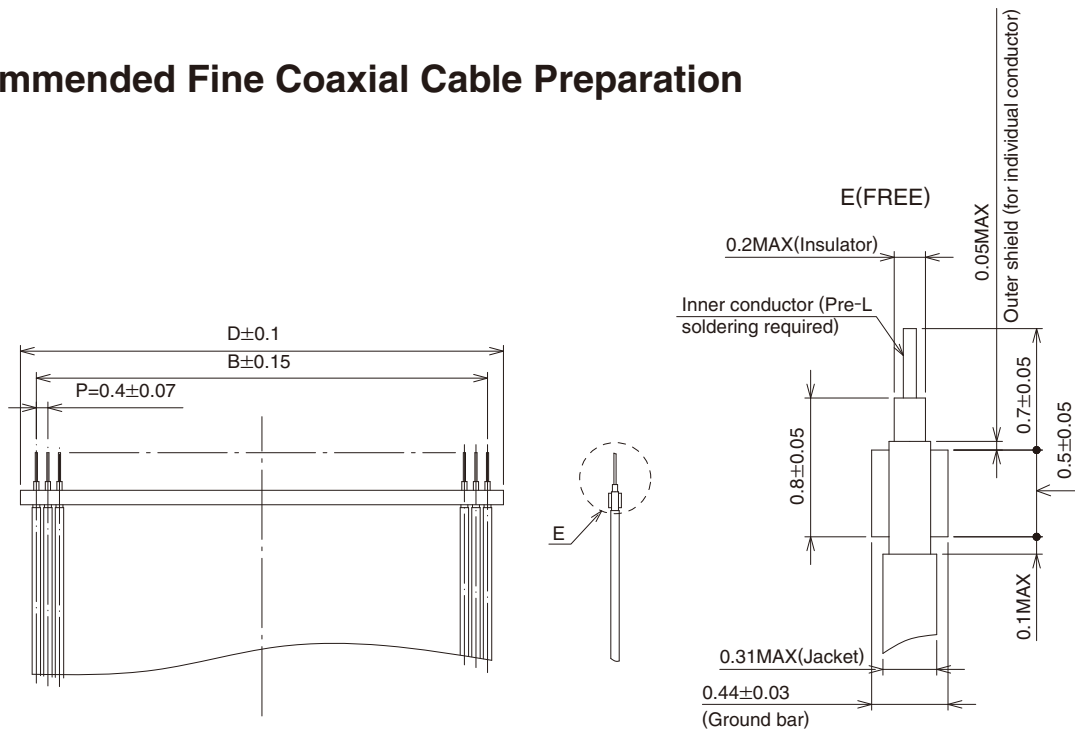

■Metal cover

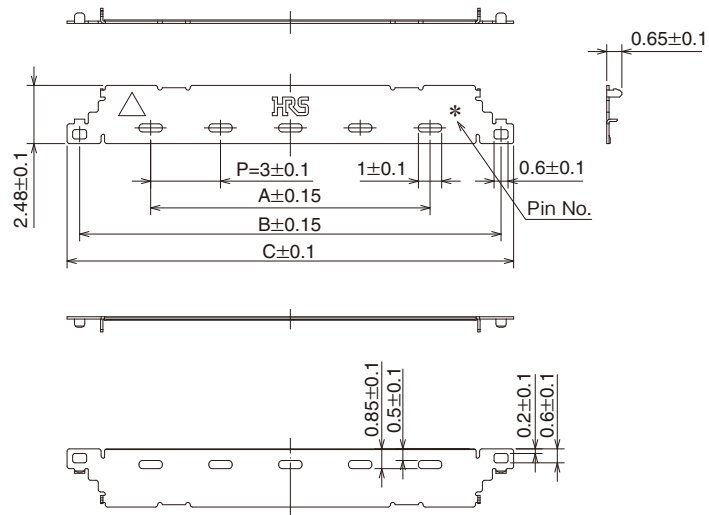
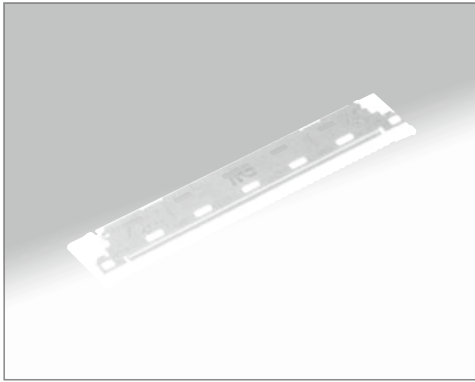

[Specification number] - **, (**)
 (51): Embossed tape packaging
 (10,000 pieces per reel)

Unit : mm

Part Number	CL No.	Number of contacts	A	B	C
DF49-20P-SHL	662-5505-0	20	4.0	10.1	11.18
DF49-30P-SHL	Under planning	30	*	14.1	15.18
DF49-40P-SHL	662-5502-1	40	12.0	18.1	19.18

Note 1 : Tape and reel packaging (10,000 pieces/reel).

Order by number of reels.

Note 2 : * dimensions will be set separately during development.

■ Packaging Specification

● Embossed Carrier Tape Dimensions

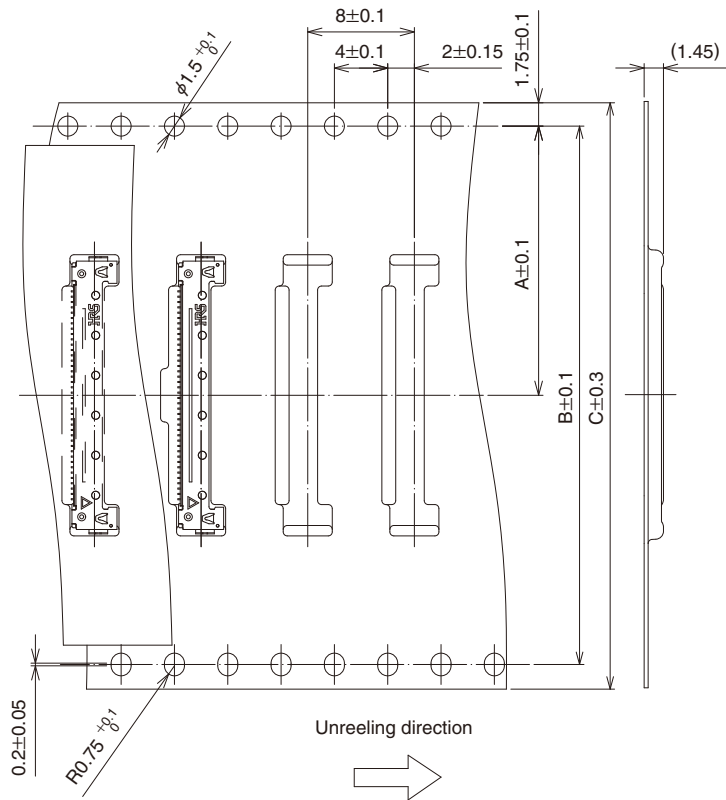

● Reel Dimensions

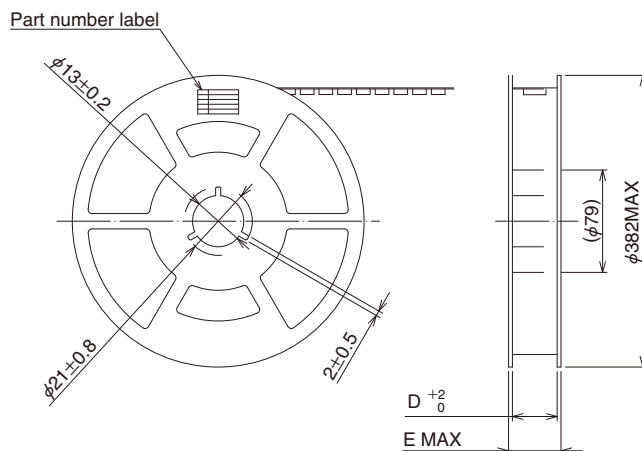

Unit : mm

Part Number	CL No.	Number of contacts	A	B	C	D	E
DF49-20S-0.4H(51)	662-5503-4-51	20	11.5	-	24.0	24.4	30.4
DF49-30S-0.4H(51)	Under planning	30	14.2	28.4	32.0	32.4	38.4
DF49-40S-0.4H(51)	662-5500-6-51	40	20.2	40.4	44.0	44.4	50.4

Note 1 : Embossed tape will have perforated feed holes on single side (20pos.)

■ Packaging Specification

● Plugs

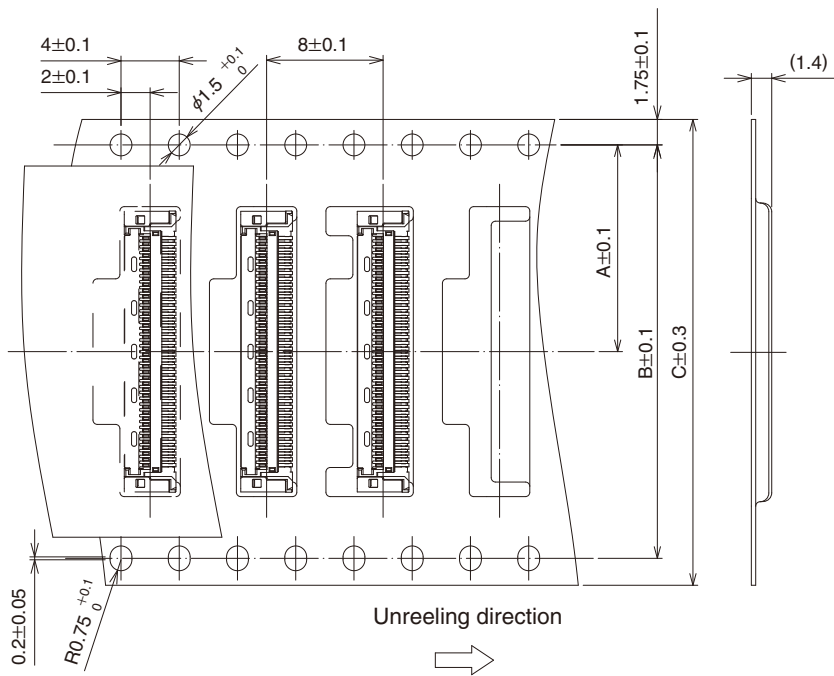

● Reel Dimensions

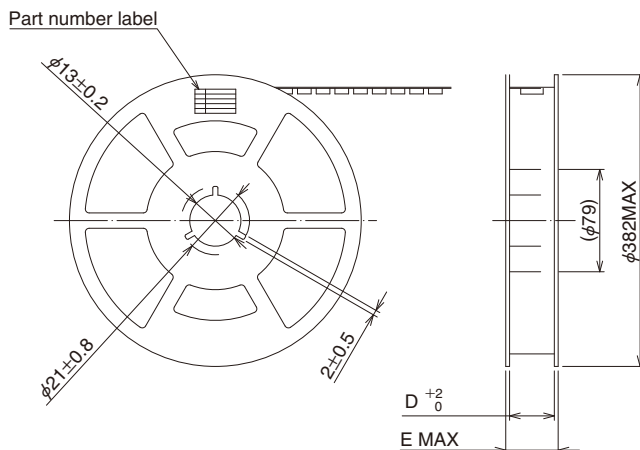

Unit : mm

Part Number	CL No.	Number of contacts	A	B	C	D	E
DF49-20P-0.4SD(51)	662-5504-7-51	20	11.5	-	24.0	24.4	30.4
DF49-30P-0.4SD(51)	Under planning	30	14.2	28.4	32.0	32.4	38.4
DF49-40P-0.4SD(51)	662-5501-9-51	40	14.2	28.4	32.0	32.4	38.4

Note 1 : Embossed tape will have perforated feed holes on single side (20pos.)

■Extraction tool

For details about the extraction tool, please contact your Hirose sales representative.

■Precautions

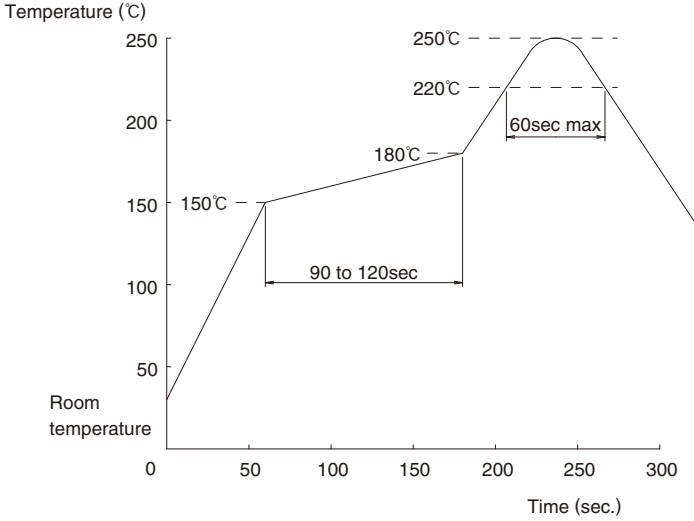
<p>1.Recommended temperature profile</p>	 <p>Solder composition : Paste, 96.5%Sn/3.0%Ag/0.5%Cu</p> <p>Note 1: Up to 2 cycles of Reflow soldering are possible under the same conditions, provided that there is a return to normal temperature between the first and second cycle.</p> <p>Note 2: The temperature profile indicates the board surface temperature at the point of contacts with the connector terminals.</p>
<p>2.Recommended manual soldering</p>	<p>Manual soldering: 350°C for 3 seconds Do NOT use flux compound when manual soldering.</p>
<p>3.Recommended screen thickness and open area ratio (Pattern area ratio)</p>	<p>Standard thickness 0.1mm Open area ratios:Lead terminal 100% :Ground terminal 75%</p>
<p>4.Board warpage</p>	<p>Maximum of 0.02mm at the connector center, with both ends of the connector as reference points.</p>
<p>5.Cleaning conditions</p>	<p>Refer to "Nylon Connector Use Handbook".</p>

■Precautions

Precautions

Mating / un-mating

Please work according to the following operational procedure:

① Confirmation of insertion direction

Upon insertion, please check the front and rear of the connector at the cable side.

On the front side, the \triangle mark, HRS mark and the display of the pole number are stamped.

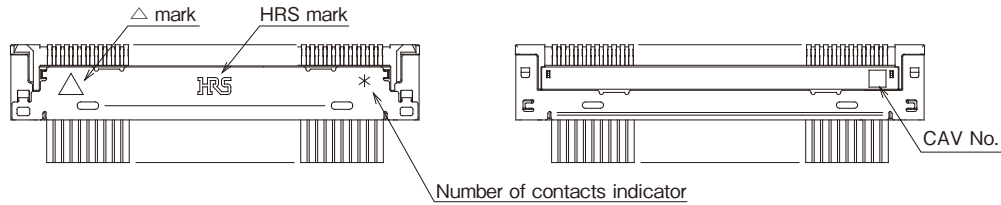

② Confirmation of temporary insertion

Please lay the plug into the receptacle gently and insert up to the temporary insertion position.

* If inserted up to the temporary insertion position, the connection can be correctly ensured.

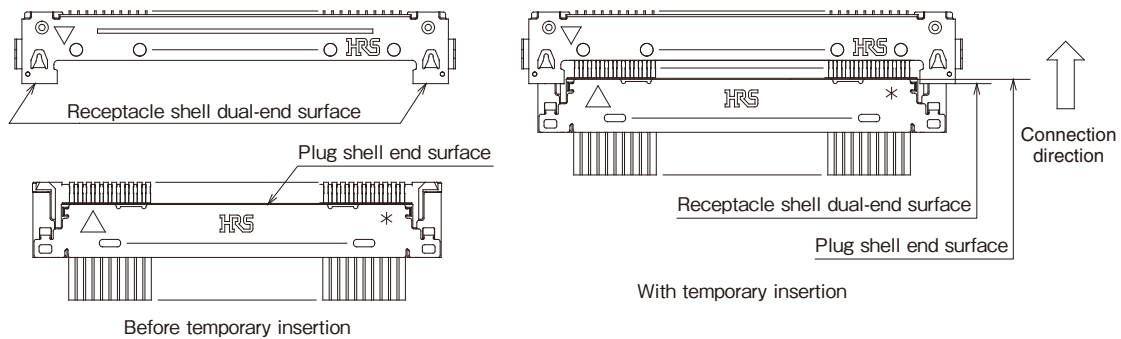

③ Confirmation of insertion

From the temporary insertion position, please push on both sides of the plug simultaneously and with equal force, to confirm the insertion.

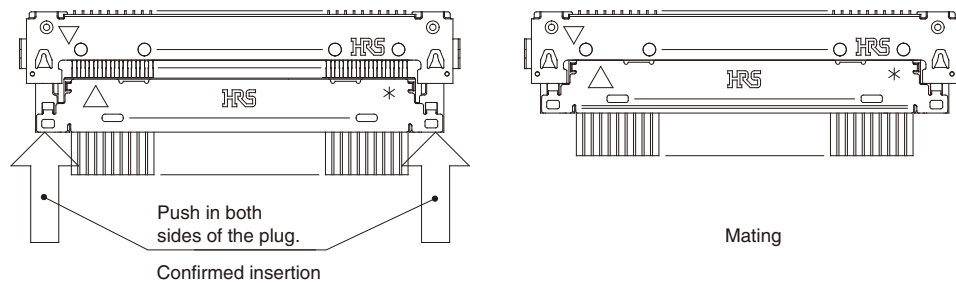

Precautions

un-mating

Use a dedicated extraction tool to un-mate the plug. Insert the tool under either end of the plug and pull as illustrated below.

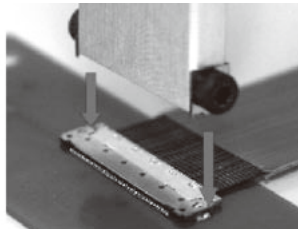

Insert the tool under either end of the plug.

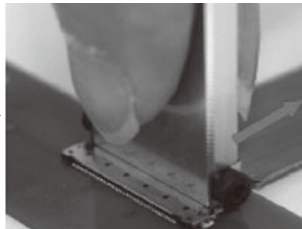

pull out the plug
(for the horizontal direction)

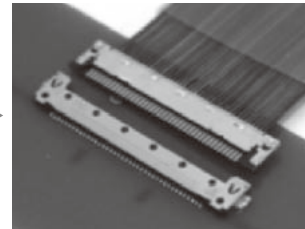

Finish

- Do not mate / un-mate the connectors when receptacle is not mounted on the board.
- In the manual soldering process, don't carry out the flux coating which will cause a flux blister on the connector.
- Excessive scoop insertion or extraction may result in damage.

Looking for pricing, stock, or lifecycle information?

Click below to explore more details on WIN SOURCE:

- ⊖ [View DF49-20P-0.4SD\(51\) on WIN SOURCE](#)
- ⊖ [Hirose Electric Co Ltd Information](#)

Optimize Your Supply Chain with WIN SOURCE Solutions

- ✓ Global Sourcing Solution
- ✓ Obsolete Management
- ✓ Cost Control Management
- ✓ Shortage Management
- ✓ Alternative Solution
- ✓ Excess Inventory Management