



# THE DATASHEET OF CYUSB3031-BZXC



# EZ-USB™ FX3S SuperSpeed USB controller

## Features

- Universal serial bus (USB) integration
  - USB 3.0 and USB 2.0 peripherals compliant with USB 3.0 specification 1.0
  - 5-Gbps USB 3.0 PHY compliant with PIPE 3.0
  - High-Speed On-The-Go (HS-OTG) host and peripheral compliant with OTG Supplement Version 2.0
  - Thirty-two physical endpoints
- General Programmable Interface (GPIF II)
  - Programmable 100-MHz GPIF II enables connectivity to a wide range of external devices
  - 8- and 16-bit data bus
  - As many as 16 configurable control signals
- Mass storage support
  - SD 3.0 (SDXC) UHS-1
  - eMMC 4.41
  - Two ports that can support memory card sizes up to 2TB
  - Built-in RAID with support for RAID0 and RAID1
- System I/O expansion with two secure digital I/O (SDIO 3.0) ports
- Support for USB-attached storage (UAS), mass-storage class (MSC), human interface device (HID), full, and Turbo-MTP
- Fully accessible 32-bit CPU
  - ARM926EJ core with 200-MHz operation
  - 512-KB or 256-KB embedded SRAM
- Additional connectivity to the following peripherals
  - I<sup>2</sup>C master controller at 1 MHz
  - I2S master (transmitter only) at sampling frequencies of 8 kHz, 16 kHz, 32 kHz, 44.1 kHz, 96 kHz, and 192 kHz
  - UART support of up to 4 Mbps
  - SPI master at 33 MHz
- Selectable clock input frequencies
  - 19.2, 26, 38.4, and 52 MHz
  - 19.2-MHz crystal input support
- Ultra low-power in core power-down mode
  - Less than 60  $\mu$ A with VBATT on
  - 20  $\mu$ A with VBATT off
- Independent power domains for core and I/O
  - Core operation at 1.2 V
  - I2S, UART, and SPI operation at 1.8 to 3.3 V
  - I<sup>2</sup>C operation at 1.2 V
- 10-mm  $\times$  10-mm, 0.8-mm pitch Pb-free ball grid array (BGA) package
- EZ-USB™ software and development kit (DVK) for easy code development

Applications

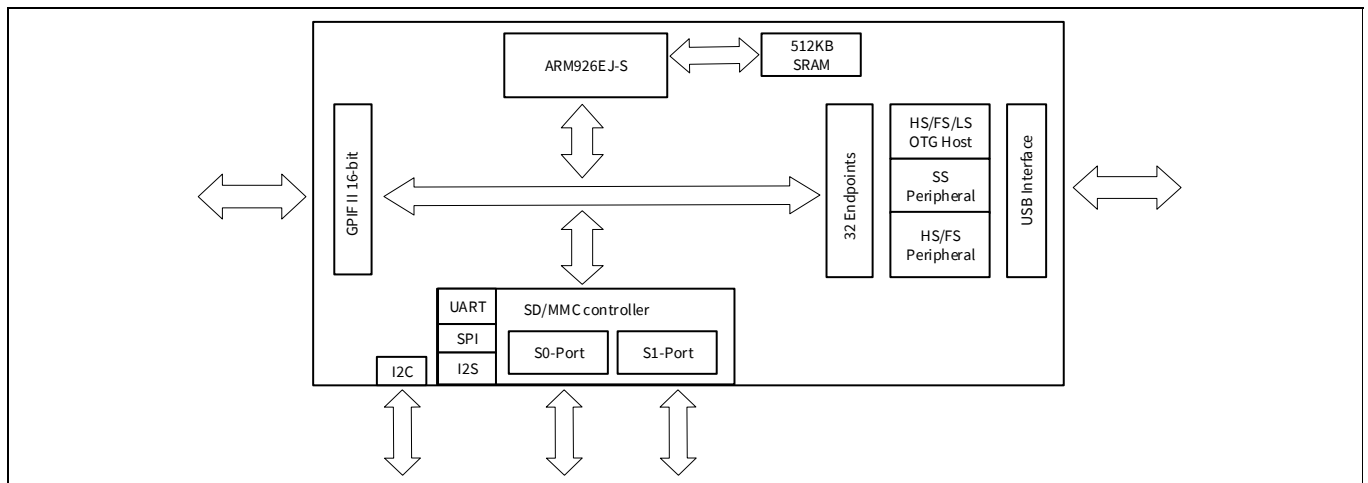
## Applications

- Digital video camcorders
- Digital still cameras
- Printers
- Scanners
- Video capture cards
- Test and measurement equipment
- Surveillance cameras
- Personal navigation devices
- Medical imaging devices
- Video IP phones
- Portable media players
- Industrial cameras
- RAID controller
- USB Disk on Module

## Functional description

For a complete list of related resources, click [here](#).

## Logic block diagram



More information

## More information

Infineon provides a wealth of data at [www.infineon.com](http://www.infineon.com) to help you to select the right <product> device for your design, and to help you to quickly and effectively integrate the device into your design.

- Overview: [USB portfolio](#)
- USB 3.0 product selectors: [EZ-USB™ FX3](#), [EZ-USB™ FX3S](#), [EZ-USB™ CX3](#), [EZ-USB™ SX3](#), [EZ-USB™ SD3](#), [EZ-USB™ HX3](#)
- Application notes: Infineon offers a large number of USB application notes covering a broad range of topics, from basic to advanced level. Recommended application notes for getting started with FX3 are:
  - [AN75705](#) - Getting started with EZ-USB™ FX3
  - [AN76405](#) - EZ-USB™ FX3 boot options
  - [AN70707](#) - EZ-USB™ FX3/FX3S hardware design guidelines and schematic checklist
  - [AN65974](#) - Designing with the EZ-USB™ FX3 slave FIFO interface
  - [AN75779](#) - How to implement an image sensor interface with EZ-USB™ FX3 in a USB Video Class (UVC) framework
  - [AN86947](#) - Optimizing USB 3.0 throughput with EZ-USB™ FX3
  - [AN84868](#) - Configuring an FPGA over USB using Infineon EZ-USB™ FX3
  - [AN68829](#) - Slave FIFO interface for EZ-USB™ FX3: 5-bit address mode
  - [AN76348](#) - Differences in implementation of EZ-USB™ FX2LP and EZ-USB™ FX3 applications
  - [AN89661](#) - USB RAID 1 disk design Using EZ-USB™ FX3S
- Code examples:
  - [USB Hi-Speed](#)
  - [USB Full-Speed](#)
  - [USB SuperSpeed](#)
- Technical reference manual (TRM):
  - [EZ-USB™ FX3 technical reference manual](#)
- Development kits:
  - [CYUSB3KIT-003](#), EZ-USB™ FX3 SuperSpeed explorer kit
- Models: [IBIS](#)

## EZ-USB™ FX3 Software Development Kit

Infineon delivers the complete software and firmware stack for FX3, in order to easily integrate SuperSpeed USB into any embedded application. The [EZ-USB™ FX3 Software Development Kit](#) (SDK) comes with tools, drivers and application examples, which help accelerate application development.

## GPIF II Designer

The [GPIF II Designer](#) is a graphical software that allows designers to configure the GPIF II interface of the EZ-USB™ FX3 USB 3.0 device controller.

The tool allows users the ability to select from one of five Infineon supplied interfaces, or choose to create their own GPIF II interface from scratch. Infineon has supplied industry standard interfaces such as asynchronous and synchronous slave FIFO, asynchronous and synchronous SRAM, and asynchronous SRAM. Designers who already have one of these pre-defined interfaces in their system can simply select the interface of choice, choose from a set of standard parameters such as bus width (x8, 16, x32) endianness, clock settings, and compile the interface. The tool has a streamlined three step GPIF interface development process for users who need a customized interface. Users are able to first select their pin configuration and standard parameters. Secondly, they can design a virtual state machine using configurable actions. Finally, users can view output timing to verify that it matches the expected timing. Once the three step process is complete, the interface can be compiled and integrated with FX3.

## Table of contents

<b>Features</b> .....	<b>1</b>
<b>Applications</b> .....	<b>2</b>
<b>Functional description</b> .....	<b>2</b>
<b>Logic block diagram</b> .....	<b>2</b>
<b>More information</b> .....	<b>3</b>
<b>EZ-USB™ FX3 Software Development Kit</b> .....	<b>3</b>
<b>GPIF II Designer</b> .....	<b>3</b>
<b>Table of contents</b> .....	<b>4</b>
<b>1 Functional overview</b> .....	<b>6</b>
1.1 Application examples .....	6
<b>2 USB interface</b> .....	<b>8</b>
2.1 OTG .....	8
2.1.1 OTG connectivity.....	8
2.2 ReNumeration.....	9
2.3 VBUS overvoltage protection .....	9
2.4 Carkit UART mode.....	9
<b>3 Host processor interface (P-Port)</b> .....	<b>10</b>
3.1 GPIF II.....	10
3.2 Slave FIFO Interface .....	11
3.3 Asynchronous SRAM .....	11
3.4 Asynchronous address/data multiplexed.....	12
3.5 Synchronous ADMux interface .....	12
3.6 Processor MMC (PMMC) slave interface .....	13
<b>4 CPU</b> .....	<b>14</b>
<b>5 Storage port (S-Port)</b> .....	<b>15</b>
5.1 SD/MMC clock stop .....	15
5.2 SD_CLK output clock stop .....	15
5.3 Card insertion and removal detection .....	15
5.4 Write Protection (WP) .....	15
5.5 SDIO interrupt .....	16
5.6 SDIO read-wait feature .....	16
<b>6 JTAG interface</b> .....	<b>17</b>
<b>7 Other interfaces</b> .....	<b>18</b>
7.1 UART interface .....	18
7.2 I2C interface .....	18
7.3 I2S interface .....	18
7.4 SPI interface .....	19
<b>8 Boot options</b> .....	<b>20</b>
<b>9 Reset</b> .....	<b>21</b>
9.1 Hard reset .....	21
9.2 Soft reset .....	21
<b>10 Clocking</b> .....	<b>22</b>
10.1 32-kHz watchdog timer clock input.....	23
<b>11 Power</b> .....	<b>24</b>
11.1 Power modes .....	24
<b>12 Configuration options</b> .....	<b>28</b>
<b>13 Digital I/Os</b> .....	<b>29</b>
<b>14 GPIOs</b> .....	<b>30</b>
<b>15 EMI</b> .....	<b>31</b>
<b>16 System-level ESD</b> .....	<b>32</b>
<b>17 Pinouts</b> .....	<b>33</b>

## Table of contents

<b>18 Pin description .....</b>	<b>34</b>
<b>19 Electrical specifications .....</b>	<b>39</b>
19.1 Absolute maximum ratings .....	39
19.2 Operating conditions .....	39
19.3 DC specifications .....	39
<b>20 Thermal characteristics .....</b>	<b>42</b>
<b>21 AC timing parameters .....</b>	<b>43</b>
21.1 GPIF II lines AC characteristics at 100 MHz .....	43
21.2 GPIF II PCLK Jitter characteristics .....	43
21.3 GPIF II timing .....	44
21.4 Asynchronous SRAM timing .....	47
21.5 ADMux timing for asynchronous access .....	50
21.6 Synchronous ADMux timing .....	52
21.7 Slave FIFO interface .....	55
21.7.1 Synchronous slave FIFO sequence description .....	55
21.7.2 Synchronous slave FIFO write sequence description .....	56
21.8 Asynchronous slave FIFO read sequence description .....	58
21.9 Asynchronous slave FIFO write sequence description .....	59
21.10 Storage port timing .....	62
21.11 Serial peripherals timing .....	65
21.11.1 I2C timing .....	65
21.11.2 I2S timing diagram .....	67
21.11.3 SPI timing specification .....	68
<b>22 Reset sequence .....</b>	<b>70</b>
<b>23 Package diagram .....</b>	<b>71</b>
<b>24 Ordering information .....</b>	<b>72</b>
24.1 Ordering code definitions .....	72
<b>25 Acronyms .....</b>	<b>73</b>
<b>26 Document conventions .....</b>	<b>74</b>
26.1 Units of measure .....	74
<b>27 Errata .....</b>	<b>75</b>
<b>Revision history .....</b>	<b>80</b>

## 1 Functional overview

Infineon EZ-USB™ FX3S is the next-generation USB 3.0 peripheral controller, providing integrated and flexible features. FX3S has a fully configurable, parallel, general programmable interface called GPIF II, which can connect to any processor, ASIC, or FPGA. GPIF II is an enhanced version of the GPIF in FX2LP, Infineon flagship USB 2.0 product. It provides easy and glueless connectivity to popular interfaces, such as asynchronous SRAM, asynchronous and synchronous address data multiplexed interfaces, and parallel ATA. FX3S has integrated the USB 3.0 and USB 2.0 physical layers (PHYs) along with a 32-bit ARM926EJ-S microprocessor for powerful data processing and for building custom applications. It implements an architecture that enables 185-MBps<sup>[1]</sup> data transfer from GPIF II to the USB interface.

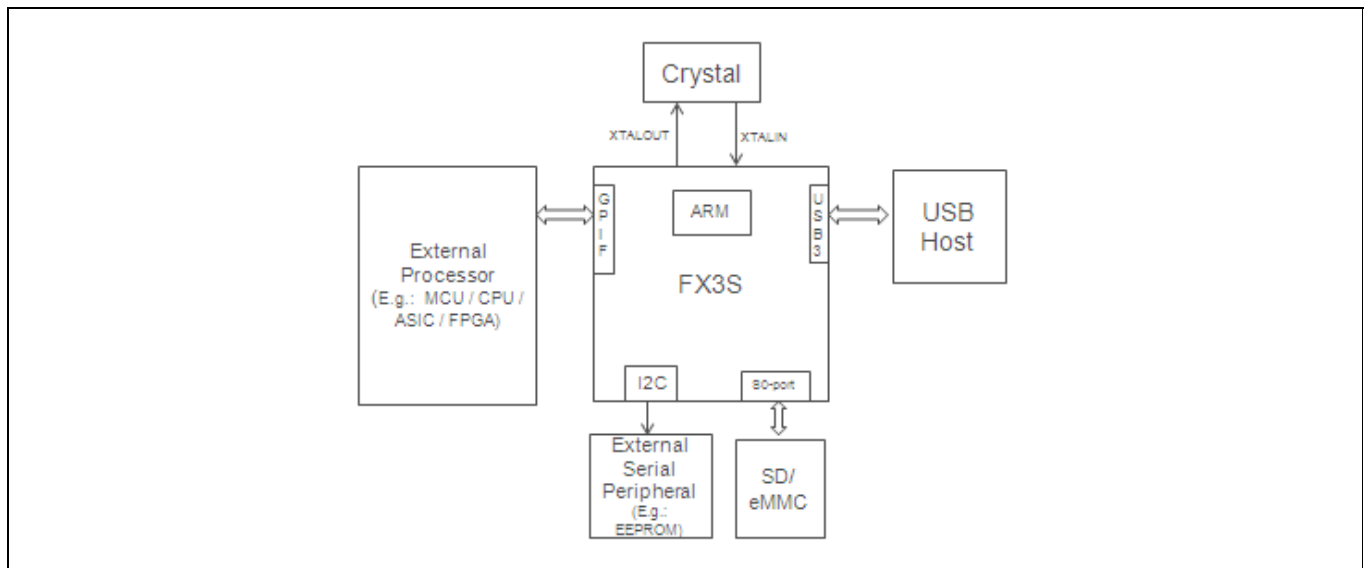
FX3S features an integrated storage controller and can support up to two independent mass storage devices on its storage ports. It can support SD 3.0 and eMMC 4.41 memory cards. It can also support SDIO 3.0 on these ports. FX3S has built in RAID with support for RAID 0 and RAID 1 using either SD or eMMC.

An integrated USB 2.0 OTG controller enables applications in which FX3S may serve dual roles; for example, EZ-USB™ FX3S may function as an OTG Host to MSC as well as HID-class devices. FX3S contains 512 KB or 256 KB of on-chip SRAM for code and data. EZ-USB™ FX3S also provides interfaces to connect to serial peripherals such as UART, SPI, I<sup>2</sup>C, and I2S. FX3S comes with application development tools. The software development kit comes with application examples for accelerating time to market.

FX3S complies with the USB 3.0 v1.0 specification and is also backward compatible with USB 2.0. It also complies with USB 2.0 OTG Specification v2.0.

### 1.1 Application examples

In a typical application (see [Figure 1](#)), FX3S functions as a coprocessor and connects to an external processor, which manages system-level functions. [Figure 2](#) shows a typical application diagram when FX3S functions as the main processor.

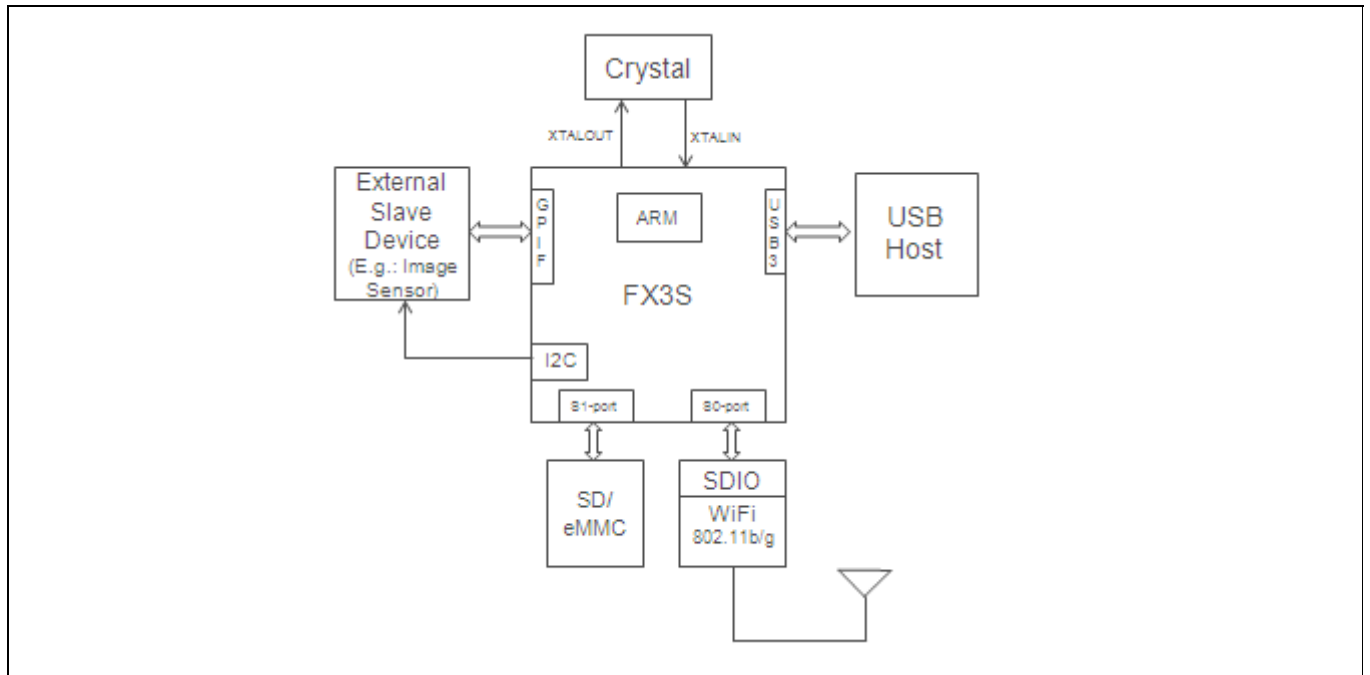


**Figure 1** EZ-USB™ FX3S as a coprocessor

#### Note

1. Assuming that GPIF II is configured for a 16-bit data bus (available with certain part numbers; see [Ordering information](#)), synchronous interface operating at 100 MHz. This number also includes protocol overheads.

## Functional overview



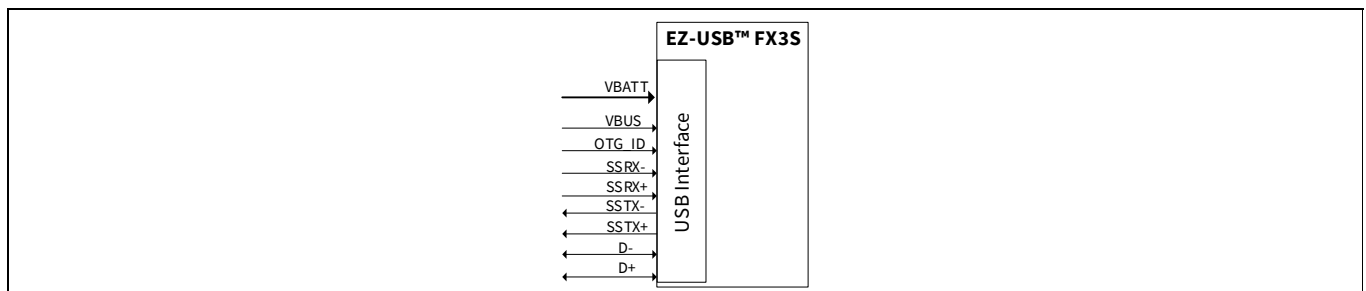
**Figure 2** EZ-USB™ FX3S as main processor

## 2 USB interface

EZ-USB™ FX3S complies with the following specifications and supports the following features:

- Supports USB peripheral functionality compliant with the USB 3.0 Specification Revision 1.0 and is also backward compatible with the USB 2.0 Specification.
- Complies with OTG Supplement Revision 2.0. It supports High-Speed, Full-Speed, and Low-Speed OTG dual-role device capability. As a peripheral, FX3S is capable of SuperSpeed, High-Speed, and Full-Speed. As a host, it is capable of High-Speed, Full-Speed, and Low-Speed.
- Supports CarKit Pass-Through UART functionality on USB D+/D– lines based on the CEA-936A specification.
- Supports up to 16 IN and 16 OUT endpoints.
- Supports USB Attached SCSI (UAS) device-class to optimize mass-storage access performance.
- As a USB peripheral, FX3S supports UAS, USB Video Class (UVC), Mass Storage Class (MSC), and Media Transfer Protocol (MTP) USB peripheral classes. As a USB peripheral, all other device classes are supported only in the pass-through mode when handled entirely by a host processor external to the device.
- As an OTG host, FX3S supports MSC and HID device classes.

**Note** When the USB port is not in use, disable the PHY and transceiver to save power.



**Figure 3** USB interface signals

### 2.1 OTG

FX3S is compliant with the OTG Specification Revision 2.0. In the OTG mode, FX3S supports both A and B device modes and supports control, interrupt, bulk, and isochronous data transfers.

FX3S requires an external charge pump (either standalone or integrated into a PMIC) to power VBUS in the OTG A-device mode.

The Target Peripheral List for OTG host implementation consists of MSC- and HID-class devices.

FX3S does not support Attach Detection Protocol (ADP).

#### 2.1.1 OTG connectivity

In OTG mode, FX3S can be configured to be an A, B, or dual-role device. It can connect to the following:

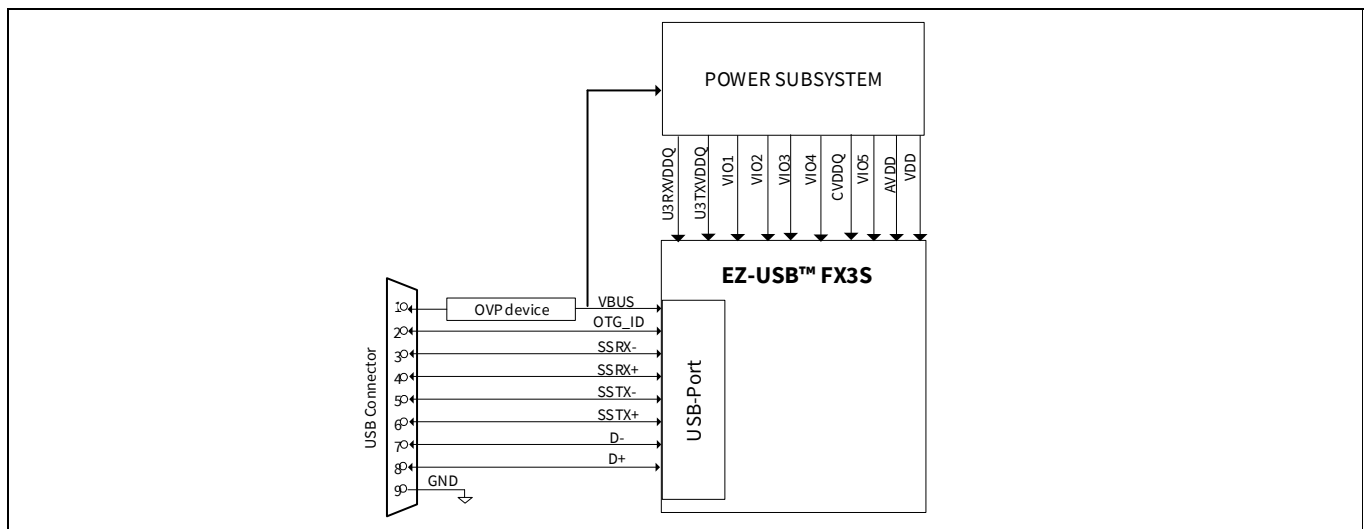
- ACA device
- Targeted USB peripheral
- SRP-capable USB peripheral
- HNP-capable USB peripheral
- OTG host
- HNP-capable host
- OTG device

## 2.2 ReNumeration

Because of FX3S's soft configuration, one chip can take on the identities of multiple distinct USB devices. When first plugged into USB, FX3S enumerates automatically with the Infineon Vendor ID (0x04B4) and downloads firmware and USB descriptors over the USB interface. The downloaded firmware executes an electrical disconnect and connect. FX3S enumerates again, this time as a device defined by the downloaded information. This patented two-step process, called ReNumeration, happens instantly when the device is plugged in.

## 2.3 VBUS overvoltage protection

The maximum input voltage on FX3S's VBUS pin is 6 V. A charger can supply up to 9 V on VBUS. In this case, an external overvoltage protection (OVP) device is required to protect FX3S from damage on VBUS. **Figure 4** shows the system application diagram with an OVP device connected on VBUS. Refer to the **DC specifications** table for the operating range of VBUS and VBATT.



**Figure 4** System diagram with OVP device for VBUS

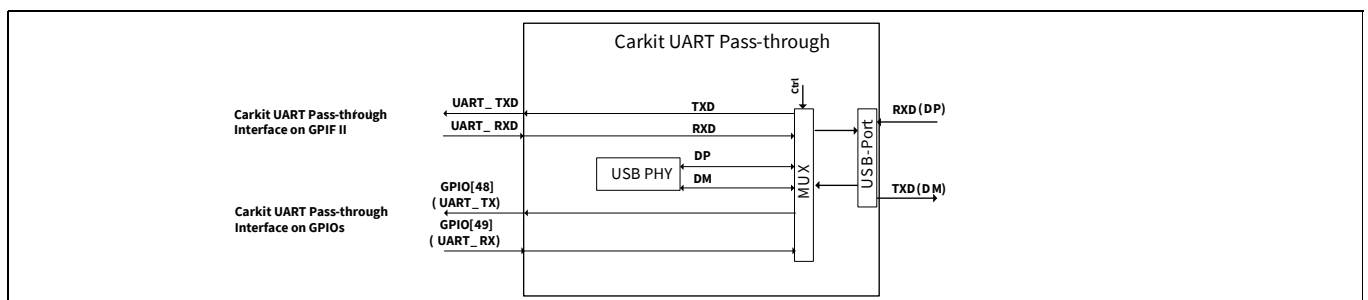
## 2.4 Carkit UART mode

The USB interface supports the Carkit UART mode (UART over D+/D-) for non-USB serial data transfer. This mode is based on the CEA-936A specification.

In the Carkit UART mode, the output signaling voltage is 3.3 V. When configured for the Carkit UART mode, TXD of UART (output) is mapped to the D- line, and RXD of UART (input) is mapped to the D+ line.

In the Carkit UART mode, FX3S disables the USB transceiver and D+ and D- pins serve as pass-through pins to connect to the UART of the host processor. The Carkit UART signals may be routed to the GPIF II interface or to GPIO[48] and GPIO[49], as shown in **Figure 5**.

In this mode, FX3S supports a rate of up to 9600 bps.



**Figure 5** Carkit UART pass-through block diagram

### 3 Host processor interface (P-Port)

A configurable interface enables FX3S to communicate with various devices such as sensor, FPGA, host processor, or a bridge chip. FX3S supports the following P-Port interfaces.

- GPIF II (16-bit)
- Slave FIFO interface
- 16-bit asynchronous SRAM interface
- 16-bit asynchronous address/data multiplexed (ADMux) interface
- 16-bit synchronous address/data multiplexed (ADMux) interface
- Processor MMC slave interface compatible with MMC System specification, MMCA Technical Committee, Version 4.2 with eMMC 4.3 and 4.4 Pass-Through boot

The following sections describe these P-Port interfaces.

#### 3.1 GPIF II

The high-performance GPIF II interface enables functionality similar to, but more advanced than, FX2LP's GPIF and slave FIFO interfaces.

The GPIF II is a programmable state machine that enables a flexible interface that may function either as a master or slave in industry-standard or proprietary interfaces. Both parallel and serial interfaces may be implemented with GPIF II.

Here are a list of GPIF II features:

- Functions as master or slave
- Provides 256 firmware programmable states
- Supports 8-bit and 16-bit parallel data bus
- Enables interface frequencies up to 100 MHz
- Supports 16 configurable control pins when a 16/8 data bus is used. All control pins can be either input/output or bi-directional.

GPIF II state transitions are based on control input signals. The control output signals are driven as a result of the GPIF II state transitions. The INT# output signal can be controlled by GPIF II. Refer to the GPIFII Designer tool. The GPIF II state machine's behavior is defined by a GPIF II descriptor. The GPIF II descriptor is designed such that the required interface specifications are met. 8 kB of memory (separate from the 512 kB of embedded SRAM) is dedicated to the GPIF II waveform where the GPIF II descriptor is stored in a specific format.

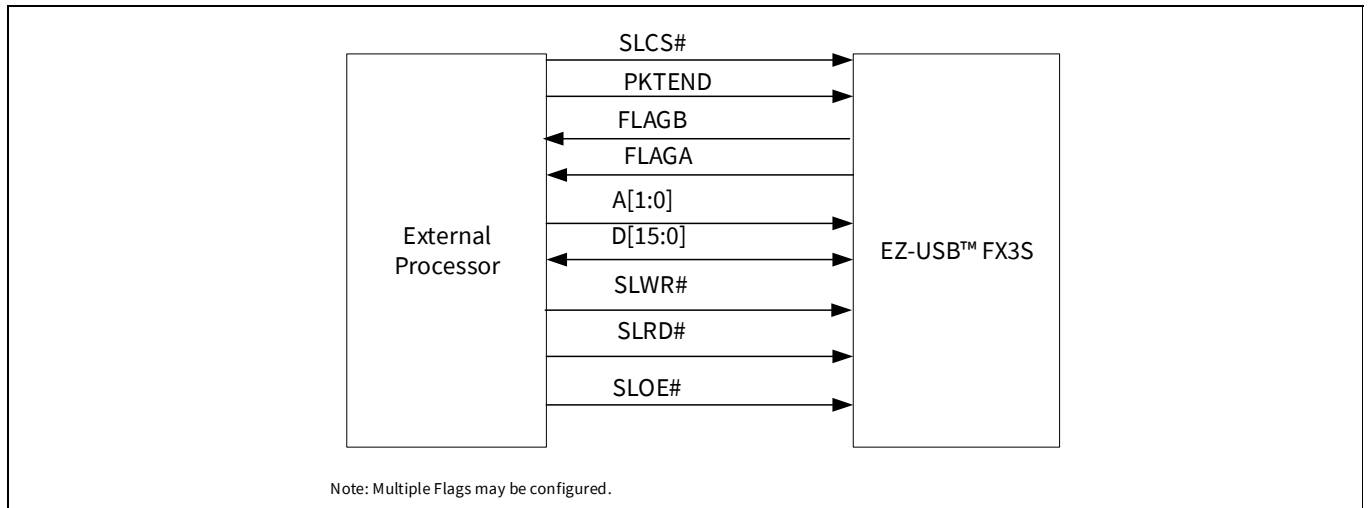
Infineon GPIF II Designer tool enables fast development of GPIF II descriptors and includes examples for common interfaces.

Example implementations of GPIF II are the asynchronous slave FIFO and synchronous slave FIFO interfaces.

### 3.2 Slave FIFO Interface

The Slave FIFO interface signals are shown in [Figure 6](#). This interface allows an external processor to directly access up to four buffers internal to FX3S. Further details of the Slave FIFO interface are described on page 55.

**Note** Access to all 32 buffers is also supported over the slave FIFO interface. For details, contact [Technical Support](#).



**Figure 6** Slave FIFO interface

### 3.3 Asynchronous SRAM

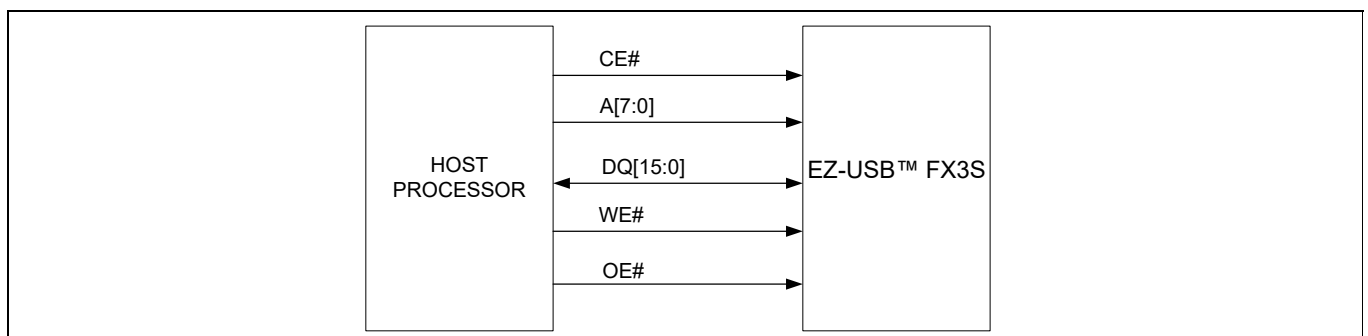
This interface consists of standard asynchronous SRAM interface signals as shown in [Figure 7](#). This interface is used to access both the configuration registers and buffer memory of FX3S. Both single-cycle and burst accesses are supported by asynchronous interface signals.

The most significant address bit, A[7], determines whether the configuration registers or buffer memory are accessed. When the configuration registers are selected by asserting the address bit A[7], the address bus bits A[6:0] point to a configuration register. When A[7] is deasserted, the buffer memory is accessed as indicated by the P-Port DMA transfer register and the transfer size is determined by the P-Port DMA transfer size register.

Application processors with a DMA controller that use address auto-increment during DMA transfers, can override this by connecting any higher-order address line (such as A[15]/A[23]/A[31]) of the application processor to FX3S's A[7].

In the asynchronous SRAM mode, when reading from a buffer memory, FX3S supports two methods of reading out next data from the buffer. The next data may be read out on the rising edge of OE# or by toggling the least significant address bit A[0].

In this mode, the P-Port interface works with a 32.5-ns minimum access cycle providing an interface data rate of up to 61.5 MB per second.

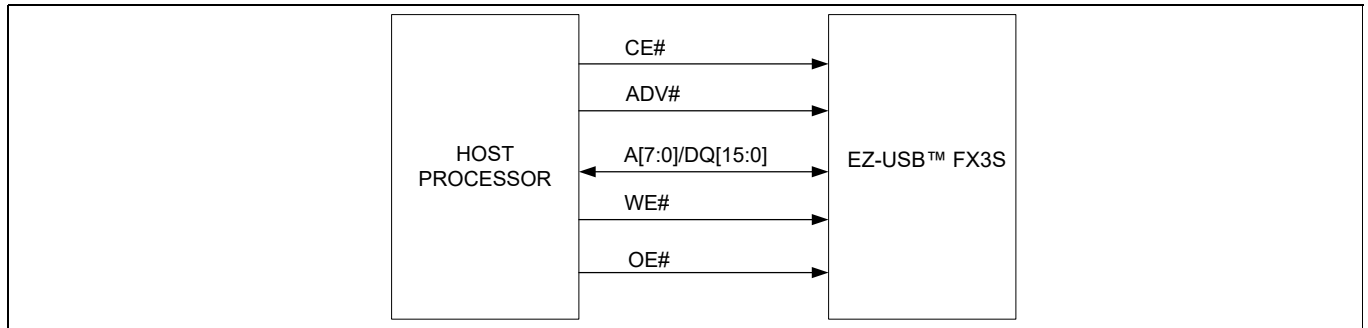


**Figure 7** Asynchronous SRAM interface

Host processor interface (P-Port)

### 3.4 Asynchronous address/data multiplexed

The physical ADMux memory interface consists of signals shown in [Figure 8](#). This interface supports processors that implement a multiplexed address/data bus.



**Figure 8** ADMux memory interface

FX3S's ADMux interface supports a 16-bit time-multiplexed address/data SRAM bus.

For read operations, assert both CE# and OE#.

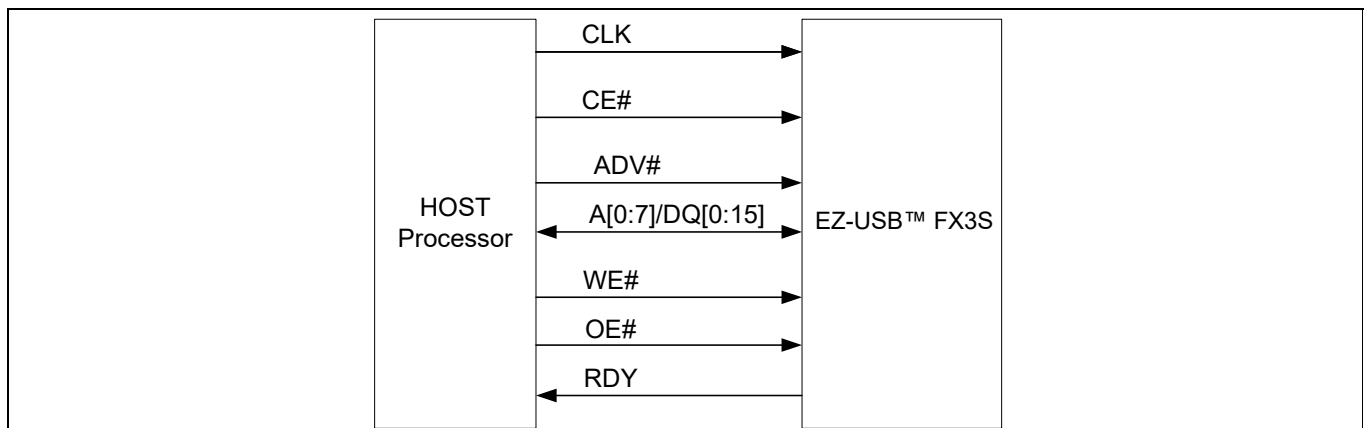
For write operations, assert both CE# and WE#. OE# is "Don't Care" during a write operation (during both address and data phase of the write cycle). The input data is latched on the rising edge of WE# or CE#, whichever occurs first. Latch the addresses prior to the write operation by toggling Address Valid (ADV#). Assert Address Valid (ADV#) during the address phase of the write operation, as shown in [Figure 19](#).

ADV# must be LOW during the address phase of a read/write operation. ADV# must be HIGH during the data phase of a read/write operation, as shown in [Figure 18](#) and [Figure 19](#).

### 3.5 Synchronous ADMux interface

FX3S's P-Port supports a synchronous address/data multiplexed interface. This operates at an interface frequency of up to 100 MHz and supports a 16-bit data bus.

The RDY output signal from the FX3S device indicates a data valid for read transfers and is acknowledged for write transfers.



**Figure 9** Synchronous ADMux interface

See the [Synchronous ADMux interface](#) timing diagrams for details.

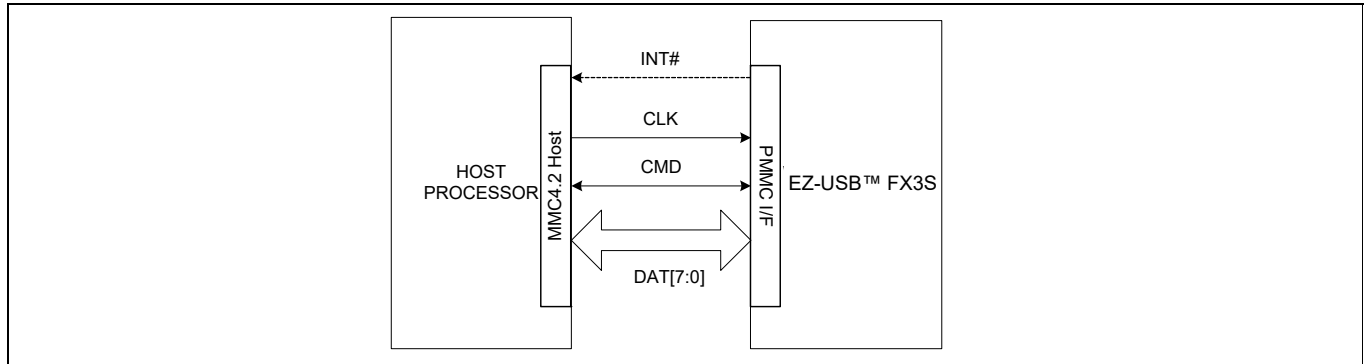
Host processor interface (P-Port)

### 3.6 Processor MMC (PMMC) slave interface

FX3S supports an MMC slave interface on the P-Port. This interface is named “PMMC” to distinguish it from the S-Port MMC interface.

**Figure 10** illustrates the signals used to connect to the host processor.

The PMMC interface’s GO\_IRQ\_STATE command allows FX3S to communicate asynchronous events without requiring the INT# signal. The use of the INT# signal is optional.



**Figure 10** PMMC interface configuration

The MMC slave interface features are as follows:

- Interface operations are compatible with the MMC-System Specification, MMCA Technical Committee, Version 4.2.
- Supports booting from an eMMC device connected to the S-Port. This feature is supported for eMMC devices operating up to 52-MHz SDR.
- Supports PMMC interface voltage ranges of 1.7 V to 1.95 V and 2.7 V to 3.6 V.
- Supports open drain (both drive and receive open drain signals) on CMD pin to allow GO\_IRQ\_STATE (CMD40) for PMMC.
- Interface clock-frequency range: 0 to 52 MHz.
- Supports 1-bit, 4-bit, or 8-bit mode of operation. This configuration is determined by the MMC initialization procedure.
- FX3S responds to standard initialization phase commands as specified for the MMC 4.2 slave device.
- PMMC mode MMC 4.2 command classes: Class 0 (Basic), Class 2 (Block read), and Class 4 (Block write), Class 9 (I/O).

FX3S supports the following PMMC commands:

- Class 0: Basic  
CMD0, CMD1, CMD2, CMD3, CMD4, CMD6, CMD7, CMD8, CMD9, CMD10, CMD12, CMD13, CMD15, CMD19, CMD5 (wakeup support)
- Class 2: Block Read  
CMD16, CMD17, CMD18, CMD23
- Class 4: Block Write  
CMD16, CMD23, CMD24, CMD25
- Class 9: I-O  
CMD39, CMD40

## 4 CPU

EZ-USB™ FX3S has an on-chip 32-bit, 200-MHz ARM926EJ-S core CPU. The core has direct access to 16 kB of Instruction Tightly Coupled Memory (TCM) and 8 kB of Data TCM. The ARM926EJ-S core provides a JTAG interface for firmware debugging.

FX3S offers the following advantages:

- Integrates 512 KB of embedded SRAM for code and data and 8 KB of Instruction cache and Data cache.
- Implements efficient and flexible DMA connectivity between the various peripherals (such as, USB, GPIF II, I<sup>2</sup>S, SPI, UART), requiring firmware only to configure data accesses between peripherals, which are then managed by the DMA fabric.
- Allows easy application development on industry-standard development tools for ARM926EJ-S.

Examples of the FX3S firmware are available with the Infineon EZ-USB™ FX3S development kit. Software APIs that can be ported to an external processor are available with the Infineon EZ-USB™ FX3S software development kit.

---

Storage port (S-Port)

## 5 Storage port (S-Port)

EZ-USB™ FX3S has two independent storage ports (S0-Port and S1-Port). Both storage ports support the following specifications:

- MMC-system specification, MMCA Technical Committee, Version 4.41
- SD specification, Version 3.0
- SDIO host controller compliant with SDIO Specification Version 3.00

Both storage ports support the following features:

### 5.1 SD/MMC clock stop

FX3S supports the stop clock feature, which can save power if the internal buffer is full when receiving data from the SD/MMC/SDIO.

### 5.2 SD\_CLK output clock stop

During the data transfer, the SD\_CLK clock can be enabled (on) or disabled (stopped) at any time by the internal flow control mechanism.

SD\_CLK output frequency is dynamically configurable using a clock divisor from a system clock. The clock choice for the divisor is user-configurable through a register. For example, the following frequencies may be configured:

- 400 kHz – For the SD/MMC card initialization
- 20 MHz – For a card with 0- to 20-MHz frequency
- 24 MHz – For a card with 0- to 26-MHz frequency
- 48 MHz – For a card with 0- to 52-MHz frequency  
(48-MHz frequency on SD\_CLK is supported when the clock input to FX3S is 19.2 MHz or 38.4 MHz)
- 52 MHz – For a card with 0- to 52-MHz frequency  
(52-MHz frequency on SD\_CLK is supported when the clock input to FX3S is 26 MHz or 52 MHz)
- 100 MHz – For a card with 0- to 100-MHz frequency

If the DDR mode is selected, data is clocked on both the rising and falling edge of the SD clock. DDR clocks run up to 52 MHz.

### 5.3 Card insertion and removal detection

FX3S supports the two-card insertion and removal detection mechanisms.

- Use of SD\_D[3] data: During system design, this signal must have an external 470-k $\Omega$  pull-down resistor connected to SD\_D[3]. SD cards have an internal 10-k $\Omega$  pull-up resistor. When the card is inserted or removed from the SD/MMC connector, the voltage level at the SD\_D[3] pin changes and triggers an interrupt to the CPU. The older generations of MMC cards do not support this card detection mechanism.
- Use of the S0/S1\_INS pin: Some SD/MMC connectors facilitate a micro switch for card insertion/removal detection. This micro switch can be connected to S0/S1\_INS. When the card is inserted or removed from the SD/MMC connector, it turns the micro switch on and off. This changes the voltage level at the pin that triggers the interrupt to the CPU. The card-detect micro switch polarity is assumed to be the same as the write-protect micro switch polarity. A low indicates that the card is inserted. This S0/S1\_INS pin is shared between the two S-Ports. Register configuration determines which port gets to use this pin. This pin is mapped to the S1VDDQ power domain; if S0VDDQ and S1VDDQ are at different voltage levels, this pin cannot be used as S1\_INS.

### 5.4 Write Protection (WP)

The S0\_WP/S1\_WP (SD Write Protection) on S-Port is used to connect to the WP micro switch of SD/MMC card connector. This pin internally connects to a CPU-accessible GPIO for firmware to detect the SD card write protection.

---

Storage port (S-Port)

## 5.5 SDIO interrupt

The SDIO interrupt functionality is supported as specified in the SDIO specification Version 2.00 (January 30, 2007).

## 5.6 SDIO read-wait feature

FX3S supports the optional read-wait and suspend-resume features as defined in the SDIO specification Version 2.00 (January 30, 2007).

## 6 JTAG interface

EZ-USB™ FX3S's JTAG interface has a standard five-pin interface to connect to a JTAG debugger in order to debug firmware through the CPU-core's on-chip-debug circuitry.

Industry-standard debugging tools for the ARM926EJ-S core can be used for the FX3S application development.

## 7 Other interfaces

EZ-USB™ FX3S supports the following serial peripherals:

- UART
- I<sup>2</sup>C
- I<sup>2</sup>S
- SPI

The SPI, UART, and I<sup>2</sup>S interfaces are multiplexed on the serial peripheral port.

### 7.1 UART interface

The UART interface of FX3S supports full-duplex communication. It includes the signals noted in [Table 1](#).

**Table 1** UART interface signals

Signal	Description
TX	Output signal
RX	Input signal
CTS	Flow control
RTS	Flow control

The UART is capable of generating a range of baud rates, from 300 bps to 4608 Kbps, selectable by the firmware. If flow control is enabled, then FX3S's UART only transmits data when the CTS input is asserted. In addition to this, FX3S's UART asserts the RTS output signal, when it is ready to receive data.

### 7.2 I<sup>2</sup>C interface

FX3S's I<sup>2</sup>C interface is compatible with the I<sup>2</sup>C Bus Specification Revision 3. This I<sup>2</sup>C interface is capable of operating only as I<sup>2</sup>C master; therefore, it may be used to communicate with other I<sup>2</sup>C slave devices. For example, FX3S may boot from an EEPROM connected to the I<sup>2</sup>C interface, as a selectable boot option.

FX3S's I<sup>2</sup>C Master Controller also supports multi-master mode functionality.

The power supply for the I<sup>2</sup>C interface is VIO5, which is a separate power domain from the other serial peripherals. This gives the I<sup>2</sup>C interface the flexibility to operate at a different voltage than the other serial interfaces.

The I<sup>2</sup>C controller supports bus frequencies of 100 kHz, 400 kHz, and 1 MHz. When VIO5 is 1.2 V, the maximum operating frequency supported is 100 kHz. When VIO5 is 1.8 V, 2.5 V, or 3.3 V, the operating frequencies supported are 400 kHz and 1 MHz. The I<sup>2</sup>C controller supports the clock-stretching feature to enable slower devices to exercise flow control.

The I<sup>2</sup>C interface's SCL and SDA signals require external pull-up resistors. The pull-up resistors must be connected to VIO5.

### 7.3 I<sup>2</sup>S interface

FX3S has an I<sup>2</sup>S port to support external audio codec devices. FX3S functions as I<sup>2</sup>S Master as transmitter only. The I<sup>2</sup>S interface consists of four signals: clock line (I2S\_CLK), serial data line (I2S\_SD), word select line (I2S\_WS), and master system clock (I2S\_MCLK). FX3S can generate the system clock as an output on I2S\_MCLK or accept an external system clock input on I2S\_MCLK.

The sampling frequencies supported by the I<sup>2</sup>S interface are 8 kHz, 16 kHz, 32 kHz, 44.1 kHz, 96 kHz, and 192 kHz.

## 7.4 SPI interface

FX3S supports an SPI Master interface on the Serial Peripherals port. The maximum operation frequency is 33 MHz.

The SPI controller supports four modes of SPI communication (see [SPI timing specification](#) for details on the modes) with the Start-Stop clock. This controller is a single-master controller with a single automated SSN control. It supports transaction sizes ranging from 4 bits to 32 bits.

## 8 Boot options

EZ-USB™ FX3S can load boot images from various sources, selected by the configuration of the PMODE pins. Following are the FX3S boot options:

- Boot from USB
- Boot from I<sup>2</sup>C
- Boot from SPI
  - Infineon SPI flash parts supported are S25FS064S (64-Mbit), S25FS128S (128-Mbit) and S25LFL064L (64-Mbit).
  - W25Q32FW (32-Mbit) is also supported.
- Boot from eMMC (S0-port)
- Boot from GPIF II Sync ADMux mode
- Boot from PMMC (P-Port)

**Table 2 FX3S booting options**

<b>PMODE[2:0]</b> <sup>[2]</sup>	<b>Boot from</b>
F00	Sync ADMux (16-bit)
F11	USB boot
F1F	I <sup>2</sup> C, on failure, USB boot is enabled
1FF	I <sup>2</sup> C only
0F1	SPI, on failure, USB boot is enabled
000	S0-port (eMMC) On failure, USB boot is enabled
100	S0-port (eMMC)

### Note

2. F indicates Floating.

## 9 Reset

### 9.1 Hard reset

A hard reset is initiated by asserting the Reset# pin on FX3S. The specific reset sequence and timing requirements are detailed in [Figure 31](#) and [Table 27](#). All I/Os are tristated during a hard reset.

### 9.2 Soft reset

In a soft reset, the processor sets the appropriate bits in the PP\_INIT control register. There are two types of Soft Reset:

- CPU Reset – The CPU Program Counter is reset. Firmware does not need to be reloaded following a CPU Reset.
- Whole Device Reset – This reset is identical to Hard Reset.
- The firmware must be reloaded following a Whole Device Reset.

## 10 Clocking

EZ-USB™ FX3S allows either a crystal to be connected between the XTALIN and XTALOUT pins or an external clock to be connected at the CLKIN pin. The XTALIN, XTALOUT, CLKIN, and CLKIN\_32 pins can be left unconnected if they are not used.

Crystal frequency supported is 19.2 MHz, while the external clock frequencies supported are 19.2, 26, 38.4, and 52 MHz.

FX3S has an on-chip oscillator circuit that uses an external 19.2-MHz ( $\pm 100$  ppm) crystal (when the crystal option is used). An appropriate load capacitance is required with a crystal. Refer to the specification of the crystal used to determine the appropriate load capacitance. The FSLC[2:0] pins must be configured appropriately to select the crystal- or clock-frequency option. The configuration options are shown in [Table 3](#).

Clock inputs to FX3S must meet the phase noise and jitter requirements specified in [Table 4](#).

The input clock frequency is independent of the clock and data rate of the FX3S core or any of the device interfaces (including P-Port and S-Port). The internal PLL applies the appropriate clock multiply option depending on the input frequency.

**Table 3** Crystal/clock frequency selection

FSLC[2]	FSLC[1]	FSLC[0]	Crystal/clock frequency
0	0	0	19.2-MHz crystal
1	0	0	19.2-MHz input CLK
1	0	1	26-MHz input CLK
1	1	0	38.4-MHz input CLK
1	1	1	52-MHz input CLK

**Table 4** FX3S input clock specifications

Parameter	Description	Specification		Units
		Min	Max	
Phase noise	100-Hz offset	–	–75	dB
	1- kHz offset	–	–104	dB
	10-kHz offset	–	–120	dB
	100-kHz offset	–	–128	dB
	1-MHz offset	–	–130	dB
Maximum frequency deviation		–	150	ppm
Duty cycle		30	70	%
Overshoot		–	3	%
Undershoot		–	–3	%
Rise time/fall time		–	3	ns

## 10.1 32-kHz watchdog timer clock input

FX3S includes a watchdog timer. The watchdog timer can be used to interrupt the ARM926EJ-S core, automatically wake up the FX3S in Standby mode, and reset the ARM926EJ-S core. The watchdog timer runs a 32-kHz clock, which may be optionally supplied from an external source on a dedicated FX3S pin.

The firmware can disable the watchdog timer.

Requirements for the optional 32-kHz clock input are listed in [Table 5](#).

**Table 5 32-kHz clock input requirements**

Parameter	Min	Max	Units
Duty cycle	40	60	%
Frequency deviation	-	±200	ppm
Rise time/fall time	-	200	ns

## 11 Power

EZ-USB™ FX3S has the following power supply domains:

- **IO\_VDDQ:** This is a group of independent supply domains for digital I/Os. The voltage level on these supplies is 1.8 V to 3.3 V. FX3S provides six independent supply domains for digital I/Os listed as follows (see [Pin description](#) for details on each of the power domain signals):
  - VIO1: GPIF II I/O
  - VIO2: S0-Port Supply
  - VIO3: S1-Port Supply
  - VIO4: S1-Port and Low Speed Peripherals (UART/SPI/I2S) Supply
  - VIO5: I<sup>2</sup>C and JTAG (supports 1.2 V to 3.3 V)
  - CVDDQ: Clock
  - V<sub>DD</sub>: This is the supply voltage for the logic core. The nominal supply-voltage level is 1.2 V. This supplies the core logic circuits. The same supply must also be used for the following:
    - AVDD: This is the 1.2-V supply for the PLL, crystal oscillator, and other core analog circuits
    - U3TXVDDQ/U3RXVDDQ: These are the 1.2-V supply voltages for the USB 3.0 interface.
- VBATT/VBUS: This is the 3.2-V to 6-V battery power supply for the USB I/O and analog circuits. This supply powers the USB transceiver through FX3S's internal voltage regulator. VBATT is internally regulated to 3.3 V.

**Note:** No specific power-up sequence for FX3S power domains. Minimum power on reset time of 1 ms should be met and the power domains must be stable for FX3S operation.

### 11.1 Power modes

FX3S supports the following power modes:

- Normal mode: This is the full-functional operating mode. The internal CPU clock and the internal PLLs are enabled in this mode.
  - Normal operating power consumption does not exceed the sum of I<sub>CC</sub> Core max and I<sub>CC</sub> USB max (see the [DC specifications](#) table for current consumption specifications).
  - The I/O power supplies VIO2, VIO3, VIO4, and VIO5 can be turned off when the corresponding interface is not in use. VIO1 cannot be turned off at any time if the GPIF II interface is used in the application.
- Low-power modes (see [Table 6](#)):
  - Suspend mode with USB 3.0 PHY enabled (L1)
  - Suspend mode with USB 3.0 PHY disabled (L2)
  - Standby mode (L3)
  - Core power-down mode (L4)

**Table 6** Entry and exit methods for low-power modes

Low-power mode	Characteristics	Methods of entry	Methods of exit
Suspend mode with USB 3.0 PHY enabled (L1)	<ul style="list-style-type: none"> <li>• The power consumption in this mode does not exceed <math>ISB_1</math></li> <li>• USB 3.0 PHY is enabled and is in U3 mode (one of the suspend modes defined by the USB 3.0 specification). This one block alone is operational with its internal clock while all other clocks are shut down</li> <li>• All I/Os maintain their previous state</li> <li>• Power supply for the wakeup source and core power must be retained. All other power domains can be turned on/off individually</li> <li>• The states of the configuration registers, buffer memory, and all internal RAM are maintained</li> <li>• All transactions must be completed before FX3S enters Suspend mode (state of outstanding transactions are not preserved)</li> <li>• The firmware resumes operation from where it was suspended (except when woken up by RESET# assertion) because the program counter does not reset</li> </ul>	<ul style="list-style-type: none"> <li>• Firmware executing on ARM926EJ-S core can put FX3S into suspend mode. For example, on USB suspend condition, firmware may decide to put FX3S into suspend mode</li> <li>• External Processor, through the use of mailbox registers, can put FX3S into suspend mode</li> </ul>	<ul style="list-style-type: none"> <li>• D+ transitioning to low or high</li> <li>• D- transitioning to low or high</li> <li>• Impedance change on OTG_ID pin</li> <li>• Resume condition on SSRX±</li> <li>• Detection of VBUS</li> <li>• Level detect on UART_CTS (programmable polarity)</li> <li>• GPIF II interface assertion of CTL[0]</li> <li>• Assertion of RESET#</li> </ul>

**Table 6** Entry and exit methods for low-power modes (continued)

Low-power mode	Characteristics	Methods of entry	Methods of exit
Suspend mode with USB 3.0 PHY disabled (L2)	<ul style="list-style-type: none"> <li>• The power consumption in this mode does not exceed <math>ISB_2</math></li> <li>• USB 3.0 PHY is disabled and the USB interface is in suspend mode</li> <li>• The clocks are shut off. The PLLs are disabled</li> <li>• All I/Os maintain their previous state</li> <li>• USB interface maintains the previous state</li> <li>• Power supply for the wakeup source and core power must be retained. All other power domains can be turned on/off individually</li> <li>• The states of the configuration registers, buffer memory and all internal RAM are maintained</li> <li>• All transactions must be completed before FX3S enters Suspend mode (state of outstanding transactions are not preserved)</li> <li>• The firmware resumes operation from where it was suspended (except when woken up by RESET# assertion) because the program counter does not reset</li> </ul>	<ul style="list-style-type: none"> <li>• Firmware executing on ARM926EJ-S core can put FX3S into suspend mode. For example, on USB suspend condition, firmware may decide to put FX3S into suspend mode</li> <li>• External Processor, through the use of mailbox registers can put FX3S into suspend mode</li> </ul>	<ul style="list-style-type: none"> <li>• D+ transitioning to low or high</li> <li>• D- transitioning to low or high</li> <li>• Impedance change on OTG_ID pin</li> <li>• Detection of VBUS</li> <li>• Level detect on UART_CTS (programmable polarity)</li> <li>• GPIF II interface assertion of CTL[0]</li> <li>• Assertion of RESET#</li> </ul>

Power

**Table 6** Entry and exit methods for low-power modes (continued)

Low-power mode	Characteristics	Methods of entry	Methods of exit
Standby mode (L3)	<ul style="list-style-type: none"> <li>The power consumption in this mode does not exceed ISB<sub>3</sub></li> <li>All configuration register settings and program/data RAM contents are preserved. However, data in the buffers or other parts of the data path, if any, is not guaranteed. Therefore, the external processor should take care that the data needed is read before putting FX3S into this Standby Mode</li> <li>The program counter is reset after waking up from Standby</li> <li>GPIO pins maintain their configuration</li> <li>Crystal oscillator is turned off</li> <li>Internal PLL is turned off</li> <li>USB transceiver is turned off</li> <li>ARM926EJ-S core is powered down. Upon wakeup, the core re-starts and runs the program stored in the program/data RAM</li> <li>Power supply for the wakeup source and core power must be retained. All other power domains can be turned on/off individually</li> </ul>	<ul style="list-style-type: none"> <li>Firmware executing on ARM926EJ-S core or external processor configures the appropriate register</li> </ul>	<ul style="list-style-type: none"> <li>Detection of VBUS</li> <li>Level detect on UART_CTS (Programmable Polarity)</li> <li>GPIF II interface assertion of CTL[0]</li> <li>Assertion of RESET#</li> </ul>
Core Power Down mode (L4)	<ul style="list-style-type: none"> <li>The power consumption in this mode does not exceed ISB<sub>4</sub></li> <li>Core power is turned off</li> <li>All buffer memory, configuration registers, and the program RAM do not maintain state. After exiting this mode, reload the firmware</li> <li>In this mode, all other power domains can be turned on/off individually</li> </ul>	<ul style="list-style-type: none"> <li>Turn off V<sub>DD</sub></li> </ul>	<ul style="list-style-type: none"> <li>Reapply VDD</li> <li>Assertion of RESET#</li> </ul>

**Note:** The power consumption depends on how the FX3S IOs are utilized in the application. See the [KBA85505](#) to estimate the current consumption by different power domains (VIO1–VIO5).

## 12 Configuration options

Configuration options are available for specific usage models. Contact Infineon Applications or Marketing for details.

## 13 Digital I/Os

EZ-USB™ FX3S has internal firmware-controlled pull-up or pull-down resistors on all digital I/O pins. An internal 50-k $\Omega$  resistor pulls the pins high, while an internal 10-k $\Omega$  resistor pulls the pins low to prevent them from floating. The I/O pins may have the following states:

- Tristated (High-Z)
- Weak pull-up (via internal 50 k $\Omega$ )
- Pull-down (via internal 10 k $\Omega$ )
- Hold (I/O hold its value) when in low-power modes
- The JTAG TDI, TMC, and TRST# signals have fixed 50-k $\Omega$  internal pull-ups, and the TCK signal has a fixed 10-k $\Omega$  pull-down resistor.

All unused I/Os should be pulled high by using the internal pull-up resistors. All unused outputs should be left floating. All I/Os can be driven at full-strength, three-quarter strength, half-strength, or quarter-strength. These drive strengths are configured separately for each interface.

## 14 GPIOs

EZ-USB™ enables a flexible pin configuration both on the GPIF II and the serial peripheral interfaces. Any unused control pins (except CTL[15]) on the GPIF II interface can be used as GPIOs. Similarly, any unused pins on the serial peripheral interfaces may be configured as GPIOs. See the [Pin description](#) for pin configuration options.

All GPIF II and GPIO pins support an external load of up to 16 pF for every pin.

---

EMI

## **15**      **EMI**

EZ-USB™ FX3S meets EMI requirements outlined by FCC 15B (USA) and EN55022 (Europe) for consumer electronics. FX3S can tolerate reasonable EMI, conducted by the aggressor, outlined by these specifications and continue to function as expected.

## 16 System-level ESD

EZ-USB™ FX3S has built-in ESD protection on the D+, D-, and GND pins on the USB interface. The ESD protection levels provided on these ports are:

- $\pm 2.2$ -KV human body model (HBM) based on JESD22-A114 Specification
- $\pm 6$ -KV contact discharge and  $\pm 8$ -KV air gap discharge based on IEC61000-4-2 level 3A
- $\pm 8$ -KV Contact Discharge and  $\pm 15$ -KV air gap discharge based on IEC61000-4-2 level 4C

This protection ensures the device continues to function after ESD events up to the levels stated in this section.

The SSRX+, SSRX-, SSTX+, and SSTX- pins only have up to  $\pm 2.2$ -KV HBM internal ESD protection.

Pinouts

## 17 Pinouts

	1	2	3	4	5	6	7	8	9	10	11
A	U3VSSQ	U3RXVDDQ	SSRXM	SSRXP	SSTXP	SSTXM	AVDD	VSS	DP	DM	NC
B	VIO4	FSLC[0]	R_USB3	FSLC[1]	U3TXVDDQ	CVDDQ	AVSS	VSS	VSS	VDD	TRST#
C	GPIO[54]	GPIO[55]	VDD	GPIO[57]	RESET#	XTALIN	XTALOUT	R_USB2	OTG_ID	TDO	VIO5
D	GPIO[50]	GPIO[51]	GPIO[52]	GPIO[53]	GPIO[56]	CLKIN_32	CLKIN	VSS	I2C_GPIO[58]	I2C_GPIO[59]	NC
E	GPIO[47]	VSS	VIO3	GPIO[49]	GPIO[48]	FSLC[2]	TDI	TMS	VDD	VBATT	VBUS
F	VIO2	GPIO[45]	GPIO[44]	GPIO[41]	GPIO[46]	TCK	GPIO[2]	GPIO[5]	GPIO[1]	GPIO[0]	VDD
G	VSS	GPIO[42]	GPIO[43]	GPIO[30]	GPIO[25]	GPIO[22]	GPIO[21]	GPIO[15]	GPIO[4]	GPIO[3]	VSS
H	VDD	GPIO[39]	GPIO[40]	GPIO[31]	GPIO[29]	GPIO[26]	GPIO[20]	GPIO[24]	GPIO[7]	GPIO[6]	VIO1
J	GPIO[38]	GPIO[36]	GPIO[37]	GPIO[34]	GPIO[28]	GPIO[16]	GPIO[19]	GPIO[14]	GPIO[9]	GPIO[8]	VDD
K	GPIO[35]	GPIO[33]	VSS	VSS	GPIO[27]	GPIO[23]	GPIO[18]	GPIO[17]	GPIO[13]	GPIO[12]	GPIO[10]
L	VSS	VSS	VSS	GPIO[32]	VDD	VSS	VDD	INT#	VIO1	GPIO[11]	VSS

**Figure 11** EZ-USB™ FX3S ball map (Top view)

## 18 Pin description

Table 7 Pin description

Pin	Power domain	I/O	Name	FX3S pin description					
				P-Port					
				GPIF II interface	Slave FIFO interface <sup>[3]</sup>	PMMC	Async SRAM	Async ADMux	Sync ADMux
F10	VIO1	I/O	GPIO[0]	DQ[0]	DQ[0]	MMC_D0	DQ[0]	DQ[0]/A[0]	DQ[0]/A[0]
F9	VIO1	I/O	GPIO[1]	DQ[1]	DQ[1]	MMC_D1	DQ[1]	DQ[1]/A[1]	DQ[1]/A[1]
F7	VIO1	I/O	GPIO[2]	DQ[2]	DQ[2]	MMC_D2	DQ[2]	DQ[2]/A[2]	DQ[2]/A[2]
G10	VIO1	I/O	GPIO[3]	DQ[3]	DQ[3]	MMC_D3	DQ[3]	DQ[3]/A[3]	DQ[3]/A[3]
G9	VIO1	I/O	GPIO[4]	DQ[4]	DQ[4]	MMC_D4	DQ[4]	DQ[4]/A[4]	DQ[4]/A[4]
F8	VIO1	I/O	GPIO[5]	DQ[5]	DQ[5]	MMC_D5	DQ[5]	DQ[5]/A[5]	DQ[5]/A[5]
H10	VIO1	I/O	GPIO[6]	DQ[6]	DQ[6]	MMC_D6	DQ[6]	DQ[6]/A[6]	DQ[6]/A[6]
H9	VIO1	I/O	GPIO[7]	DQ[7]	DQ[7]	MMC_D7	DQ[7]	DQ[7]/A[7]	DQ[7]/A[7]
J10	VIO1	I/O	GPIO[8]	DQ[8]/A0 <sup>[4]</sup>	DQ[8]/A0 <sup>[4]</sup>	GPIO	DQ[8]	DQ[8]/A[8]	DQ[8]/A[8]
J9	VIO1	I/O	GPIO[9]	DQ[9]/A1 <sup>[4]</sup>	DQ[9]/A1 <sup>[4]</sup>	GPIO	DQ[9]	DQ[9]/A[9]	DQ[9]/A[9]
K11	VIO1	I/O	GPIO[10]	DQ[10]	DQ[10]	GPIO	DQ[10]	DQ[10]/A[10]	DQ[10]/A[10]
L10	VIO1	I/O	GPIO[11]	DQ[11]	DQ[11]	GPIO	DQ[11]	DQ[11]/A[11]	DQ[11]/A[11]
K10	VIO1	I/O	GPIO[12]	DQ[12]	DQ[12]	GPIO	DQ[12]	DQ[12]/A[12]	DQ[12]/A[12]
K9	VIO1	I/O	GPIO[13]	DQ[13]	DQ[13]	GPIO	DQ[13]	DQ[13]/A[13]	DQ[13]/A[13]
J8	VIO1	I/O	GPIO[14]	DQ[14] <sup>[5]</sup>	DQ[14]	GPIO	DQ[14]	DQ[14]/A[14]	DQ[14]/A[14]
G8	VIO1	I/O	GPIO[15]	DQ[15] <sup>[5]</sup>	DQ[15]	GPIO	DQ[15]	DQ[15]/A[15]	DQ[15]/A[15]
J6	VIO1	I/O	GPIO[16]	PCLK	CLK	MMC_CLK	CLK	CLK	CLK
K8	VIO1	I/O	GPIO[17]	CTL[0]	SLCS#	GPIO	CE#	CE#	CE#
K7	VIO1	I/O	GPIO[18]	CTL[1]	SLWR#	MMC_CMD	WE#	WE#	WE#
J7	VIO1	I/O	GPIO[19]	CTL[2]	SLOE#	GPIO	OE#	OE#	OE#
H7	VIO1	I/O	GPIO[20]	CTL[3]	SLRD#	GPIO	DACK#	DACK#	DACK#
G7	VIO1	I/O	GPIO[21]	CTL[4]	FLAGA	GPIO	DRQ#	DRQ#	DRQ#
G6	VIO1	I/O	GPIO[22]	CTL[5]	FLAGB	GPIO	A[7]	GPIO	GPIO
K6	VIO1	I/O	GPIO[23]	CTL[6]	GPIO	GPIO	A[6]	GPIO	RDY

### Notes

- Slave FIFO is an example configuration of GPIF II Interface. The Slave FIFO control signal assignments can be modified using GPIF-II designer tool.
- For 8-bit data bus configuration, GPIO[8] and GPIO[9] act as address lines.
- GPIF II can also be configured as a serial interface. The DQ[15] pin becomes a serial output and DQ[14] becomes a serial input in this mode.

## Pin description

**Table 7** Pin description (continued)

Pin	Power domain	I/O	Name	FX3S pin description					
				P-Port					
				GPIF II interface	Slave FIFO interface <sup>[3]</sup>	PMMC	Async SRAM	Async ADMux	Sync ADMux
H8	VIO1	I/O	GPIO[24]	CTL[7]	PKTEND#	GPIO	A[5]	GPIO	GPIO
G5	VIO1	I/O	GPIO[25]	CTL[8]	GPIO	GPIO	A[4]	GPIO	GPIO
H6	VIO1	I/O	GPIO[26]	CTL[9]	GPIO	GPIO	A[3]	GPIO	GPIO
K5	VIO1	I/O	GPIO[27]	CTL[10]	GPIO	GPIO	A[2]	ADV#	ADV#
J5	VIO1	I/O	GPIO[28]	CTL[11]	A1	CARKIT_U ART_RX	A[1]	GPIO	GPIO
H5	VIO1	I/O	GPIO[29]	CTL[12]	A0	CARKIT_U ART_TX	A[0]	GPIO	GPIO
G4	VIO1	I/O	GPIO[30]	PMODE[0]	PMODE[0]	PMODE[0]	PMODE[0]	PMODE[0]	PMODE[0]
H4	VIO1	I/O	GPIO[31]	PMODE[1]	PMODE[1]	PMODE[1]	PMODE[1]	PMODE[1]	PMODE[1]
L4	VIO1	I/O	GPIO[32]	PMODE[2]	PMODE[2]	PMODE[2]	PMODE[2]	PMODE[2]	PMODE[2]
L8	VIO1	I/O	INT#	INT#/CTL[15]	CTL[15]	INT#	INT#	INT#	INT#
C5	CVDDQ	I	RESET#	RESET#	RESET#	RESET#	RESET#	RESET#	RESET#

**Table 8** Pin description

Pin	Power domain	I/O	Name	FX3S pin description		
				S0-Port		
				8b MMC	SD+GPIO	GPIO
J4	VIO2	I/O	GPIO[34]	S0_SD1	S0_SD1	GPIO
K1	VIO2	I/O	GPIO[35]	S0_SD2	S0_SD2	GPIO
J2	VIO2	I/O	GPIO[36]	S0_SD3	S0_SD3	GPIO
J3	VIO2	I/O	GPIO[37]	S0_SD4	GPIO	GPIO
J1	VIO2	I/O	GPIO[38]	S0_SD5	GPIO	GPIO
H2	VIO2	I/O	GPIO[39]	S0_SD6	GPIO	GPIO
H3	VIO2	I/O	GPIO[40]	S0_SD7	GPIO	GPIO
F4	VIO2	I/O	GPIO[41]	S0_CMD	S0_CMD	GPIO
G2	VIO2	I/O	GPIO[42]	S0_CLK	S0_CLK	GPIO
G3	VIO2	I/O	GPIO[43]	S0_WP	S0_WP	GPIO
F3	VIO2	I/O	GPIO[44]	S0S1_INS	S0S1_INS	GPIO
F2	VIO2	I/O	GPIO[45]	MMC0_RST_OUT	GPIO	GPIO

## Pin description

**Table 8** Pin description (continued)

Pin	Power domain	I/O	Name	FX3S pin description							
				S1-Port							
				8b MMC	SD+ UART	SD+ SPI	SD+ GPIO	SD+ I2S	GPIO	GPIO+ UART+I2S	UART+ SPI+I2S
F5	VIO3	I/O	GPIO[46]	S1_SD0	S1_SD0	S1_SD0	S1_SD0	S1_SD0	GPIO	GPIO	UART_RT S
E1	VIO3	I/O	GPIO[47]	S1_SD1	S1_SD1	S1_SD1	S1_SD1	S1_SD1	GPIO	GPIO	UART_CT S
E5	VIO3	I/O	GPIO[48]	S1_SD2	S1_SD2	S1_SD2	S1_SD2	S1_SD2	GPIO	GPIO	UART_TX
E4	VIO3	I/O	GPIO[49]	S1_SD3	S1_SD3	S1_SD3	S1_SD3	S1_SD3	GPIO	GPIO	UART_RX
D1	VIO3	I/O	GPIO[50]	S1_CMD	S1_CMD	S1_CM D	S1_CM D	S1_CM D	GPIO	I2S_CLK	I2S_CLK
D2	VIO3	I/O	GPIO[51]	S1_CLK	S1_CLK	S1_CLK	S1_CLK	S1_CLK	GPIO	I2S_SD	I2S_SD
D3	VIO3	I/O	GPIO[52]	S1_WP	S1_WP	S1_WP	S1_WP	S1_WP	GPIO	I2S_WS	I2S_WS
D4	VIO4	I/O	GPIO[53]	S1_SD4	UART_ RTS	SPI_SC K	GPIO	GPIO	GPIO	UART_RT S	SPI_SCK
C1	VIO4	I/O	GPIO[54]	S1_SD5	UART_ CTS	SPI_SS N	GPIO	I2S_CL K	GPIO	UART_CT S	SPI_SSN
C2	VIO4	I/O	GPIO[55]	S1_SD6	UART_TX	SPI_MIS O	GPIO	I2S_SD	GPIO	UART_TX	SPI_MIS O
D5	VIO4	I/O	GPIO[56]	S1_SD7	UART_RX	SPI_MO SI	GPIO	I2S_WS	GPIO	UART_RX	SPI_MOS I
C4	VIO4	I/O	GPIO[57]	MMC1_ RST_OU T	GPIO	GPIO	GPIO	I2S_MC LK	GPIO	I2S_MCLK	I2S_MCL K

**Note:** In FX3S variants without support for the S1-port (CYUSB3031 and CYUSB3033), the S1-port pins can still be used as GPIO, GPIO+UART+I2S, and UART+SPI+I2S configurations.

**Table 9** Pin description

Pin	Power domain	I/O	Name	FX3S pin description
				USB port
C9	VBUS/ VBATT	I	OTG_ID	OTG_ID
A3	U3RX VDDQ	I	SSRXM	SSRX-
A4	U3RX VDDQ	I	SSRXP	SSRX+
A6	U3TX VDDQ	O	SSTXM	SSTX-
A5	U3TX VDDQ	O	SSTXP	SSTX+
A9	VBUS/ VBATT	I/O	DP	D+
A10	VBUS/ VBATT	I/O	DM	D-

## Pin description

**Table 9** Pin description (continued)

Pin	Power domain	I/O	Name	FX3S pin description
A11			NC	No connect
<b>Crystal/clocks</b>				
B2	CVDDQ	I	FSLC[0]	FSLC[0]
C6	AVDD	I/O	XTALIN	XTALIN
C7	AVDD	I/O	XTALOUT	XTALOUT
B4	CVDDQ	I	FSLC[1]	FSLC[1]
E6	CVDDQ	I	FSLC[2]	FSLC[2]
D7	CVDDQ	I	CLKIN	CLKIN
D6	CVDDQ	I	CLKIN_32	CLKIN_32
<b>I2C and JTAG</b>				
D9	VIO5	I/O	I2C_GPIO[58]	I2C_SCL
D10	VIO5	I/O	I2C_GPIO[59]	I2C_SDA
E7	VIO5	I	TDI	TDI
C10	VIO5	O	TDO	TDO
B11	VIO5	I	TRST#	TRST#
E8	VIO5	I	TMS	TMS
F6	VIO5	I	TCK	TCK
D11	VIO5	O	O[60]	GPIO

**Table 10** Pin description

FX3S pin description				
Pin	Power domain	I/O	Name	Power
B10		PWR	VDD	
A1		PWR	U3VSSQ	
E11		PWR	VBUS	
D8		PWR	VSS	
H11		PWR	VIO1	
E2		PWR	VSS	
L9		PWR	VIO1	
G1		PWR	VSS	
F1		PWR	VIO2	
G11		PWR	VSS	
E3		PWR	VIO3	
L1		PWR	VSS	
B1		PWR	VIO4	
L6		PWR	VSS	
B6		PWR	CVDDQ	
B5		PWR	U3TXVDDQ	
A2		PWR	U3RXVDDQ	
C11		PWR	VIO5	

## Pin description

**Table 10** Pin description (continued)

FX3S pin description				
Pin	Power domain	I/O	Name	Power
L11		PWR	VSS	
A7		PWR	AVDD	
B7		PWR	AVSS	
C3		PWR	VDD	
B8		PWR	VSS	
E9		PWR	VDD	
B9		PWR	VSS	
F11		PWR	VDD	
H1		PWR	VDD	
L7		PWR	VDD	
J11		PWR	VDD	
L5		PWR	VDD	
K4		PWR	VSS	
L3		PWR	VSS	
K3		PWR	VSS	
L2		PWR	VSS	
A8		PWR	VSS	
				<b>Precision resistors</b>
C8	VBUS/ VBATT	I/O	R_usb2	Precision resistor for USB 2.0 (Connect a 6.04 kΩ ±1% resistor between this pin and GND)
B3	U3TX VDDQ	I/O	R_usb3	Precision resistor for USB 3.0 (Connect a 200 Ω ±1% resistor between this pin and GND)

## Electrical specifications

## 19 Electrical specifications

### 19.1 Absolute maximum ratings

Exceeding maximum ratings may shorten the useful life of the device.

Storage temperature .....	-65°C to +150°C
Ambient temperature with power supplied (Industrial) .....	-40°C to +85°C
Supply voltage to ground potential	
$V_{DD}$ , $A_{VDDQ}$ .....	1.25 V
$V_{IO1}$ , $V_{IO2}$ , $V_{IO3}$ , $V_{IO4}$ , $V_{IO5}$ .....	3.6 V
$U3TX_{VDDQ}$ , $U3RX_{VDDQ}$ .....	1.25 V
DC input voltage to any input pin .....	$V_{CC} + 0.3$
DC voltage applied to outputs in high Z state .....	$V_{CC} + 0.3$

(VCC is the corresponding I/O voltage)

Static discharge voltage ESD protection levels:

- $\pm 2.2$ -KV HBM based on JESD22-A114
- Additional ESD protection levels on D+, D-, and GND pins, and serial peripheral pins
- $\pm 6$ -KV contact discharge,  $\pm 8$ -KV air gap discharge based on IEC61000-4-2 level 3A,  $\pm 8$ -KV contact discharge, and  $\pm 15$ -KV air gap discharge based on IEC61000-4-2 level 4C

Latch-up current .....

Maximum output short-circuit current for all I/O configurations. ( $V_{out} = 0$  V) .....

### 19.2 Operating conditions

$T_A$  (ambient temperature under bias)

Industrial .....	-40°C to +85°C
$V_{DD}$ , $A_{VDDQ}$ , $U3TX_{VDDQ}$ , $U3RX_{VDDQ}$ supply voltage .....	1.15 V to 1.25 V
$V_{BATT}$ supply voltage .....	3.2 V to 6 V
$V_{IO1}$ , $V_{IO2}$ , $V_{IO3}$ , $V_{IO4}$ , $C_{VDDQ}$ supply voltage .....	1.7 V to 3.6 V
$V_{IO5}$ supply voltage .....	1.15 V to 3.6 V

### 19.3 DC specifications

**Table 11 DC specifications**

Parameter	Description	Min	Max	Units	Notes
$V_{DD}$	Core voltage supply	1.15	1.25	V	1.2-V typical
$A_{VDD}$	Analog voltage supply	1.15	1.25	V	1.2-V typical
$V_{IO1}$	GPIF II I/O power supply domain	1.7	3.6	V	1.8-, 2.5-, and 3.3-V typical
$V_{IO2}$	S0-Port power supply domain	1.7	3.6	V	1.8-, 2.5-, and 3.3-V typical
$V_{IO3}$	S1-Port power supply domain	1.7	3.6	V	1.8-, 2.5-, and 3.3-V typical
$V_{IO4}$	S1-Port and UART/SPI/I2S power supply domain	1.7	3.6	V	1.8-, 2.5-, and 3.3-V typical
$V_{BATT}$	USB voltage supply	3.2	6	V	3.7-V typical

## Electrical specifications

**Table 11** DC specifications (continued)

Parameter	Description	Min	Max	Units	Notes
V <sub>BUS</sub>	USB voltage supply	4.0	6	V	5-V typical
U3TX <sub>VDDQ</sub>	USB 3.0 1.2-V supply	1.15	1.25	V	1.2-V typical. A 22-μF bypass capacitor is required on this power supply.
U3RX <sub>VDDQ</sub>	USB 3.0 1.2-V supply	1.15	1.25	V	1.2-V typical. A 22-μF bypass capacitor is required on this power supply.
C <sub>VDDQ</sub>	Clock voltage supply	1.7	3.6	V	1.8-, 3.3-V typical
V <sub>I05</sub>	I <sup>2</sup> C and JTAG voltage supply	1.15	3.6	V	1.2-, 1.8-, 2.5-, and 3.3-V typical
V <sub>IH1</sub>	Input HIGH voltage 1	$0.625 \times V_{CC}$	$V_{CC} + 0.3$	V	For $2.0 \text{ V} \leq V_{CC} \leq 3.6 \text{ V}$ (except USB port). $V_{CC}$ is the corresponding I/O voltage supply.
V <sub>IH2</sub>	Input HIGH voltage 2	$V_{CC} - 0.4$	$V_{CC} + 0.3$	V	For $1.7 \text{ V} \leq V_{CC} \leq 2.0 \text{ V}$ (except USB port). $V_{CC}$ is the corresponding I/O voltage supply.
V <sub>IL</sub>	Input LOW voltage	-0.3	$0.25 \times V_{CC}$	V	$V_{CC}$ is the corresponding I/O voltage supply.
V <sub>OH</sub>	Output HIGH voltage	$0.9 \times V_{CC}$	-	V	$I_{OH}(\text{max}) = -100 \mu\text{A}$ tested at quarter drive strength. $V_{CC}$ is the corresponding I/O voltage supply. Refer to <a href="#">Table 12</a> for values of $I_{OH}$ at various drive strength and $V_{CC}$ .
V <sub>OL</sub>	Output LOW voltage	-	$0.1 \times V_{CC}$	V	$I_{OL}(\text{min}) = +100 \mu\text{A}$ tested at quarter drive strength. $V_{CC}$ is the corresponding I/O voltage supply. Refer to <a href="#">Table 12</a> for values of $I_{OL}$ at various drive strength and $V_{CC}$ .
I <sub>IX</sub>	Input leakage current for all pins except SSTXP/SSXM/SSRXP/SSRXM	-1	1	μA	All I/O signals held at V <sub>DDQ</sub> (For I/Os with a pull-up or pull-down resistor connected, the leakage current increases by $V_{DDQ}/R_{pu}$ or $V_{DDQ}/R_{pd}$ )
I <sub>OZ</sub>	Output High-Z leakage current for all pins except SSTXP/SSXM/SSRXP/SSRXM	-1	1	μA	All I/O signals held at V <sub>DDQ</sub>
I <sub>CC Core</sub>	Core and analog voltage operating current	-	200	mA	Total current through A <sub>VDD</sub> , V <sub>DD</sub>
I <sub>CC USB</sub>	USB voltage supply operating current	-	60	mA	
I <sub>SB1</sub>	Total suspend current during suspend mode with USB 3.0 PHY enabled (L1)	-	-	mA	Core current: 1.5 mA I/O current: 20 μA USB current: 2 mA For typical PVT (typical silicon, all power supplies at their respective nominal levels at 25°C.)

## Electrical specifications

**Table 11** DC specifications (continued)

Parameter	Description	Min	Max	Units	Notes
$I_{SB2}$	Total suspend current during suspend mode with USB 3.0 PHY disabled (L2)	–	–	mA	Core current: 250 $\mu$ A I/O current: 20 $\mu$ A USB current: 1.2 mA For typical PVT (Typical silicon, all power supplies at their respective nominal levels at 25°C.)
$I_{SB3}$	Total standby current during standby mode (L3)	–	–	$\mu$ A	Core current: 60 $\mu$ A I/O current: 20 $\mu$ A USB current: 40 $\mu$ A For typical PVT (typical silicon, all power supplies at their respective nominal levels at 25°C.)
$I_{SB4}$	Total standby current during core power-down mode (L4)	–	–	$\mu$ A	Core current: 0 $\mu$ A I/O current: 20 $\mu$ A USB current: 40 $\mu$ A For typical PVT (typical silicon, all power supplies at their respective nominal levels at 25°C.)
$V_{RAMP}$	Voltage ramp rate on core and I/O supplies	0.2	50	V/ms	Voltage ramp must be monotonic
$V_N$	Noise level permitted on $V_{DD}$ and I/O supplies	–	100	mV	Max p-p noise level permitted on all supplies except $A_{VDD}$
$V_{N\_AVDD}$	Noise level permitted on $A_{VDD}$ supply	–	20	mV	Max p-p noise level permitted on $A_{VDD}$

**Table 12**  $I_{OH}/I_{OL}$  values for different drive strength and  $V_{DDIO}$  values

$V_{DDIO}$ (V)	$V_{OH}$ (V)	$V_{OL}$ (V)	Drive strength	$I_{OH\ max}$ (mA)	$I_{OL\ min}$ (mA)
1.7	1.53	0.17	Quarter	1.02	2.21
			Half	1.51	3.28
			Three-Quarters	1.83	3.85
			Full	2.28	4.73
2.5	2.25	0.25	Quarter	5.03	3.96
			Half	7.38	5.84
			Three-Quarters	8.89	6.89
			Full	11.07	8.61
3.6	3.24	0.36	Quarter	7.80	5.74
			Half	11.36	8.64
			Three-Quarters	13.64	10.15
			Full	16.92	12.67

## 20 Thermal characteristics

**Table 13 Thermal characteristics**

Parameter	Description	Value	Unit
$T_{J\ MAX}$	Maximum junction temperature	125	°C
$\Theta_{JA}$	Thermal resistance (junction to ambient)	34.66	°C/W
$\Theta_{JB}$	Thermal resistance (junction to board)	27.03	°C/W
$\Theta_{JC}$	Thermal resistance (junction to case)	13.57	°C/W

## 21 AC timing parameters

### 21.1 GPIF II lines AC characteristics at 100 MHz

**Table 14** GPIF II lines AC characteristics at 100 MHz

Symbol	Parameter	Min	Typ	Max	Unit
Tr	Rise time	–	–	2.5	ns
Tf	Fall time	–	–	2.5	ns
Tov	Overshoot	–	–	3	%
Tun	Undershoot	–	–	3	%

### 21.2 GPIF II PCLK Jitter characteristics

**Table 15** GPIF II PCLK Jitter characteristics

Clk Freq (MHz)	Period Jitter (ps)	C-C min (ps)	C-C max (ps)
10.08	354.44	–187.92	204.55
25.2	205.97	–153.54	126.53
50.4	144.62	–100.16	85.769
100.8	171.43	–155.13	157.14

**Note:** The clock jitter is measured using internally generated PCLK. i.e., PCLK is configured as an output from GPIF. The data is measured over 10,000 clock cycles.

## AC timing parameters

## 21.3 GPIF II timing

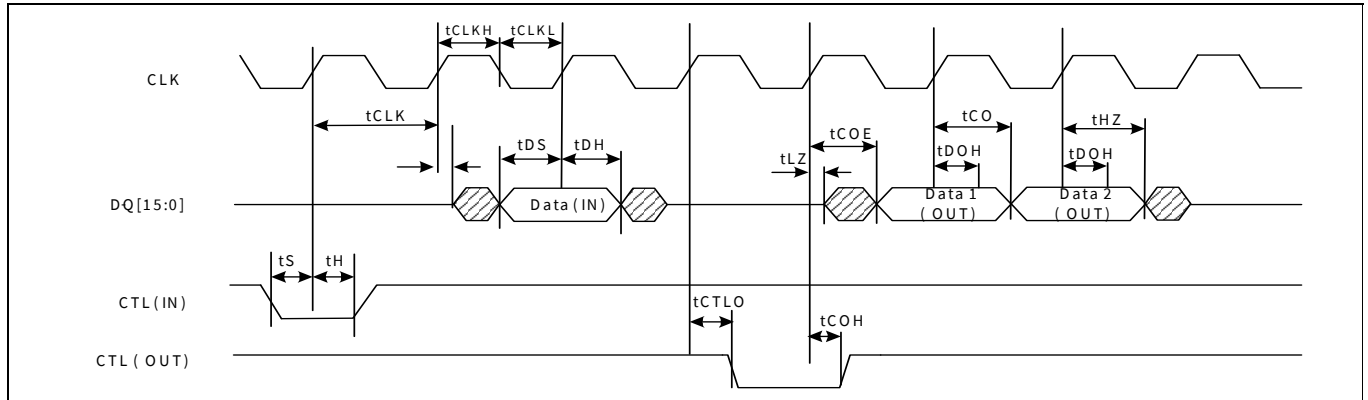


Figure 12 GPIF II timing in synchronous mode

Table 16 GPIF II Timing parameters in synchronous mode

Parameter <sup>[6]</sup>	Description	Min	Max	Units
Frequency	Interface clock frequency	–	100	MHz
tCLK	Interface clock period	10	–	ns
tCLKH	Clock high time	4	–	ns
tCLKL	Clock low time	4	–	ns
tS	CTL input to clock setup time (Sync speed = 1)	2	–	ns
tH	CTL input to clock hold time (Sync speed = 1)	0.5	–	ns
tDS	Data in to clock setup time (Sync speed = 1)	2	–	ns
tDH	Data in to clock hold time (Sync speed = 1)	0.5	–	ns
tCO	Clock to data out propagation delay when DQ bus is already in output direction (Sync speed = 1)	–	7	ns
tCOE	Clock to data out propagation delay when DQ lines change to output from tristate and valid data is available on the DQ bus (Sync speed = 1)	–	9	ns
tCTLO	Clock to CTL out propagation delay (Sync speed = 1)	–	8	ns
tDOH	Clock to data out hold	2	–	ns
tCOH	Clock to CTL out hold	0	–	ns
tHZ	Clock to high-Z	–	8	ns
tLZ	Clock to low-Z (Sync speed = 1)	0	–	ns
tS_ss0	CTL input/data input to clock setup time (Sync speed = 0)	5	–	ns
tH_ss0	CTL input/data input to clock hold time (Sync speed = 0)	2.5	–	ns
tCO_ss0	Clock to data out / CTL out propagation delay (sync speed = 0)	–	15	ns
tLZ_ss0	Clock to low-Z (sync speed = 0)	2	–	ns

**Note**

6. All parameters guaranteed by design and validated through characterization.

AC timing parameters

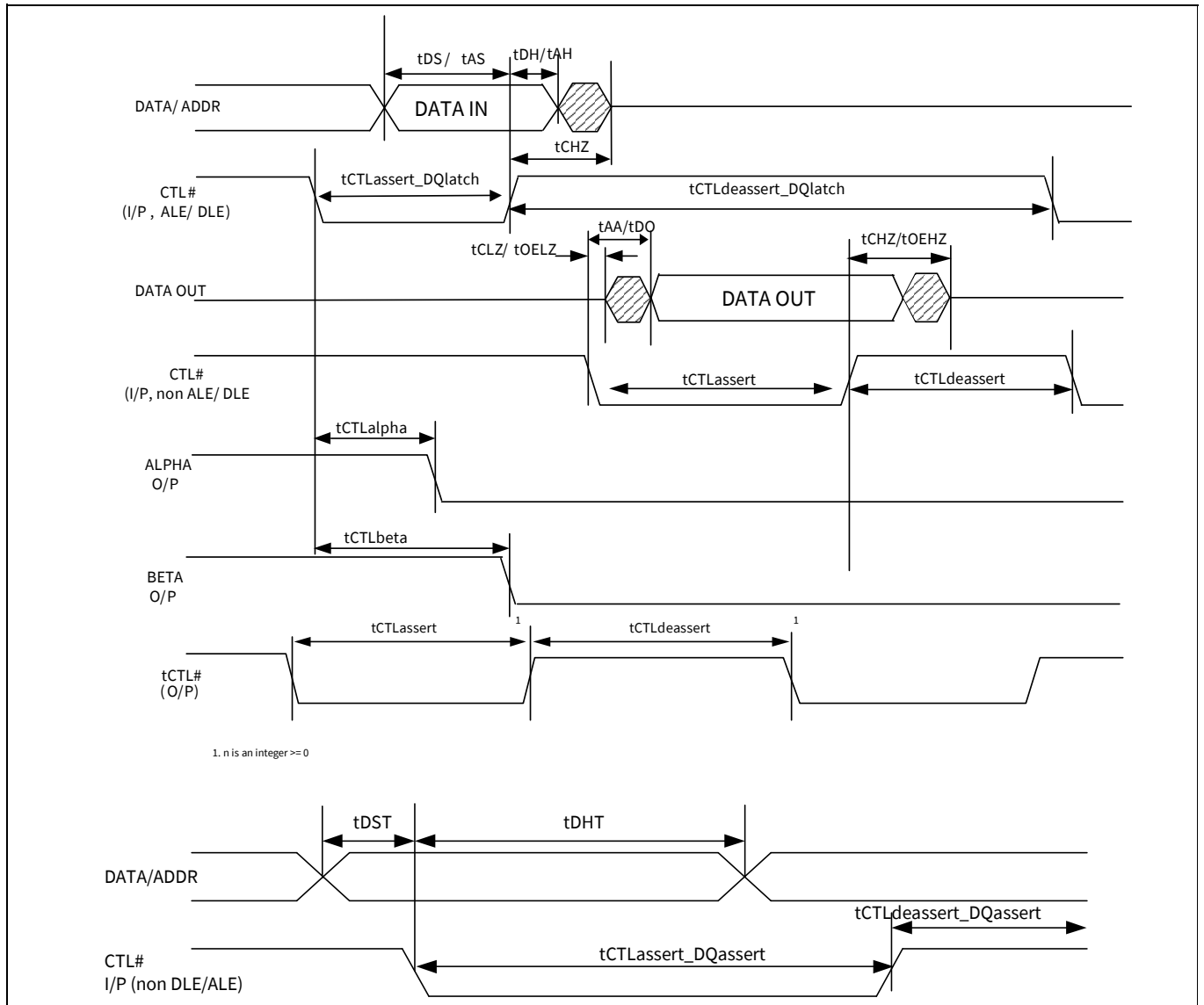


Figure 13 GPIF II timing in asynchronous mode

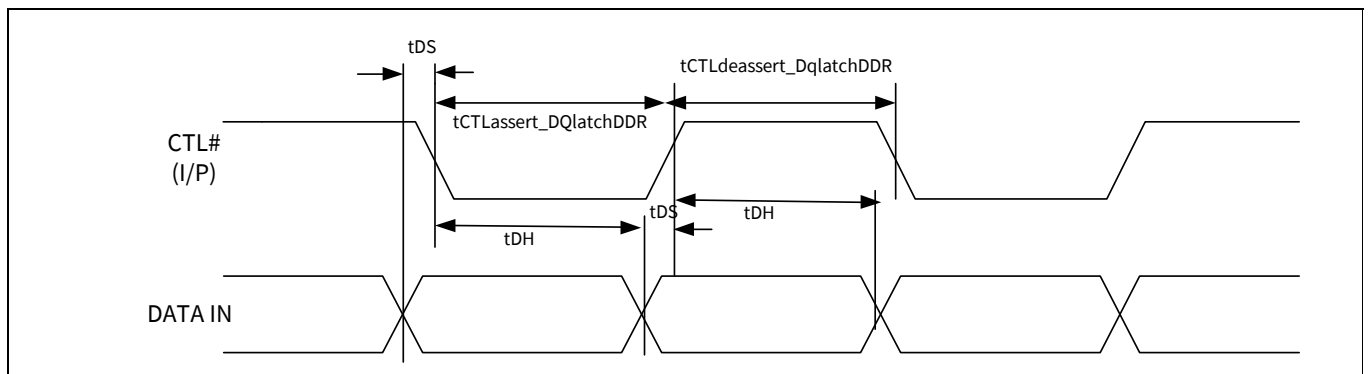


Figure 14 GPIF II timing in asynchronous DDR mode

## AC timing parameters

**Table 17 GPIF II timing in asynchronous mode**

**Note** The following parameters assume one state transition.

Parameter <sup>[7]</sup>	Description	Min	Max	Units
tDS	Data In to DLE setup time. Valid in DDR async mode.	2.3	–	ns
tDH	Data In to DLE hold time. Valid in DDR async mode.	2	–	ns
tAS	Address In to ALE setup time	2.3	–	ns
tAH	Address In to ALE hold time	2	–	ns
tCTLassert	CTL I/O asserted width for CTRL inputs without DQ input association and for outputs.	7	–	ns
tCTLdeassert	CTL I/O deasserted width for CTRL inputs without DQ input association and for outputs.	7	–	ns
tCTLassert_DQassert	CTL asserted pulse width for CTL inputs that signify DQ inputs valid at the asserting edge but do not employ in-built latches (ALE/DLE) for those DQ inputs.	20	–	ns
tCTLdeassert_DQassert	CTL deasserted pulse width for CTL inputs that signify DQ input valid at the asserting edge but do not employ in-built latches (ALE/DLE) for those DQ inputs.	7	–	ns
tCTLassert_DQdeassert	CTL asserted pulse width for CTL inputs that signify DQ inputs valid at the deasserting edge but do not employ in-built latches (ALE/DLE) for those DQ inputs.	7	–	ns
tCTLdeassert_DQdeassert	CTL deasserted pulse width for CTL inputs that signify DQ inputs valid at the deasserting edge but do not employ in-built latches (ALE/DLE) for those DQ inputs.	20	–	ns
tCTLassert_DQlatch	CTL asserted pulse width for CTL inputs that employ in-built latches (ALE/DLE) to latch the DQ inputs. In this non-DDR case, in-built latches are always close at the deasserting edge.	7	–	ns
tCTLdeassert_DQlatch	CTL deasserted pulse width for CTL inputs that employ in-built latches (ALE/DLE) to latch the DQ inputs. In this non-DDR case, in-built latches always close at the deasserting edge.	10	–	ns
tCTLassert_DQlatchDDR	CTL asserted pulse width for CTL inputs that employ in-built latches (DLE) to latch the DQ inputs in DDR mode.	10	–	ns
tCTLdeassert_D-QlatchDDR	CTL deasserted pulse width for CTL inputs that employ in-built latches (DLE) to latch the DQ inputs in DDR mode.	10	–	ns
tAA	DQ/CTL input to DQ output time when DQ change or CTL change needs to be detected and affects internal updates of input and output DQ lines.	–	30	ns
tDO	CTL to data out when the CTL change merely enables the output flop update whose data was already established.	–	25	ns
tOELZ	CTL designated as OE to low-Z. Time when external devices should stop driving data.	0	–	ns
tOEZH	CTL designated as OE to high-Z	8	8	ns

**Note**

7. All parameters guaranteed by design and validated through characterization.

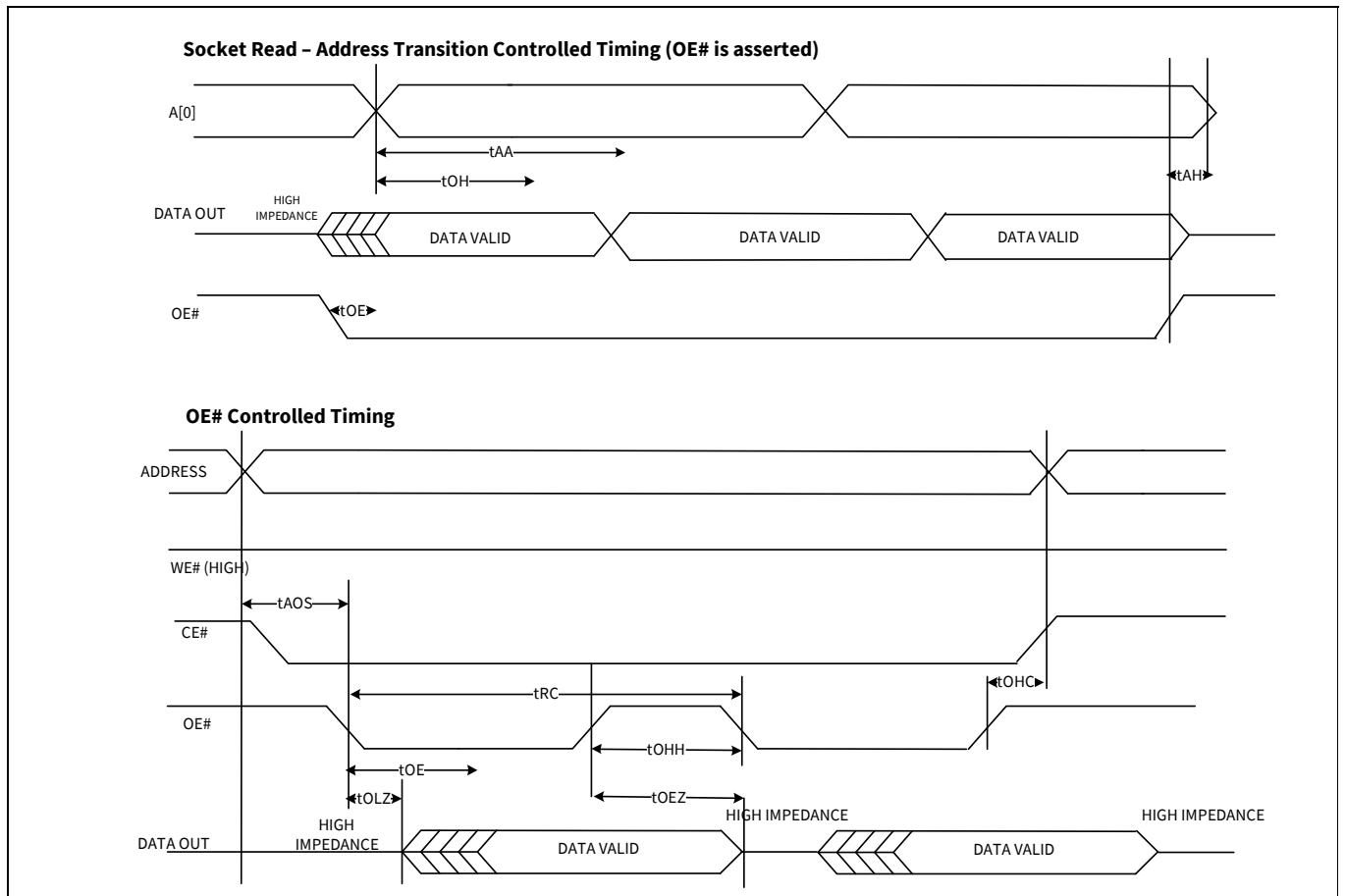
AC timing parameters

**Table 17 GPIF II timing in asynchronous mode (continued)**

**Note** The following parameters assume one state transition.

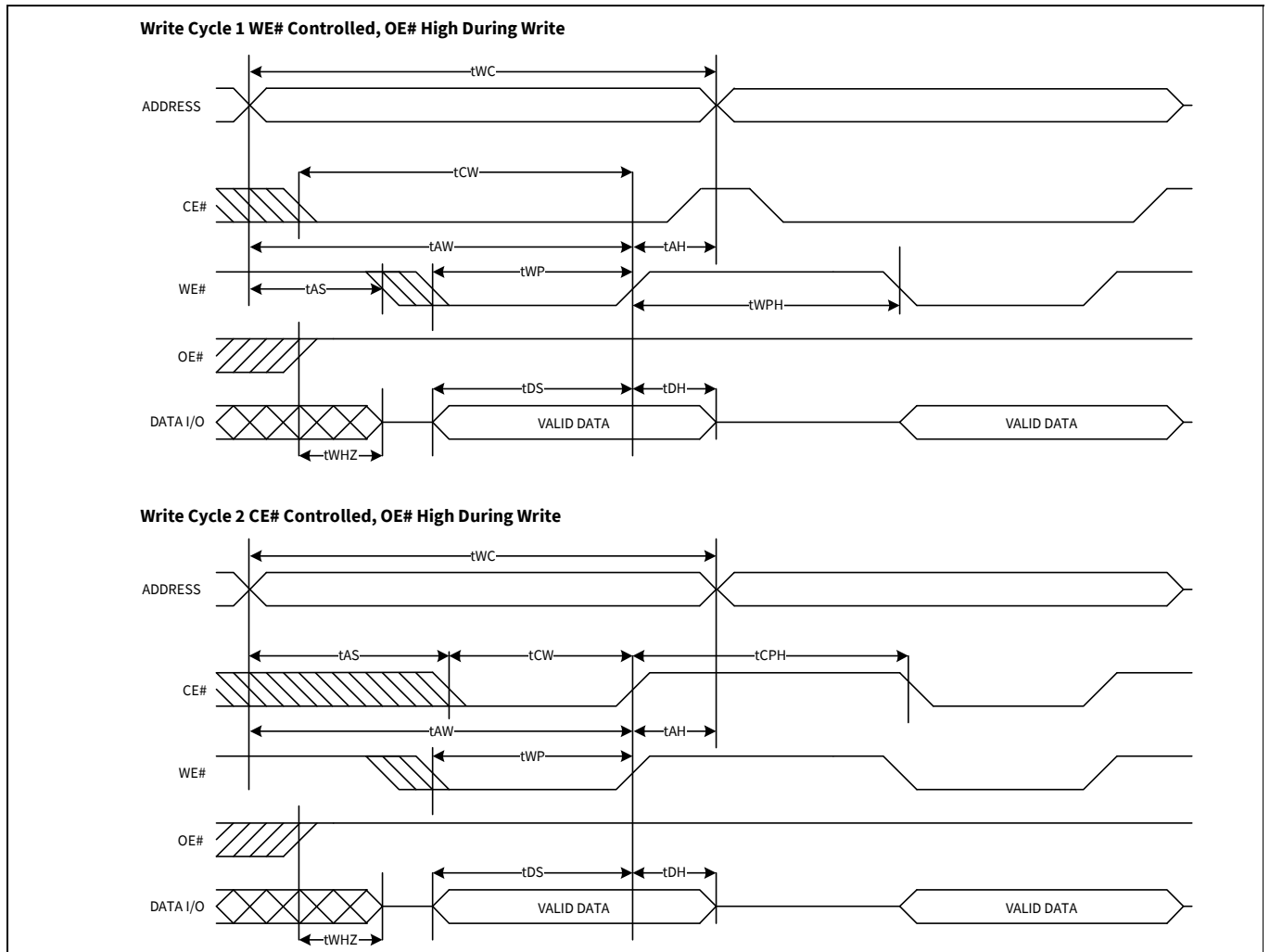
Parameter <sup>[7]</sup>	Description	Min	Max	Units
tCLZ	CTL (non-OE) to low-Z. Time when external devices should stop driving data.	0	-	ns
tCHZ	CTL (non-OE) to high-Z	30	30	ns
tCTLalpha	CTL to alpha change at output	-	25	ns
tCTLbeta	CTL to beta change at output	-	30	ns
tDST	Addr/data setup when DLE/ALE not used	2	-	ns
tDHT	Addr/data hold when DLE/ALE not used	20	-	ns

**21.4 Asynchronous SRAM timing**

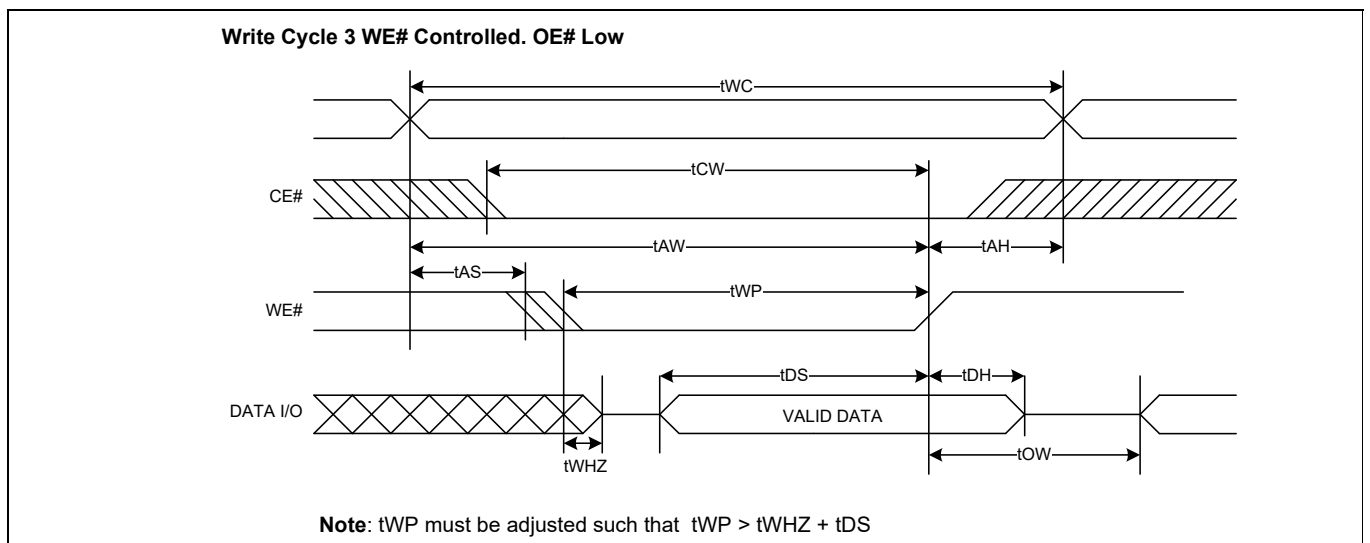


**Figure 15 Non-multiplexed asynchronous SRAM read timing**

AC timing parameters



**Figure 16 Non-multiplexed asynchronous SRAM write timing (WE# and CE# controlled)**



**Figure 17 Non-multiplexed asynchronous SRAM write timing (WE# controlled, OE# LOW)**

## AC timing parameters

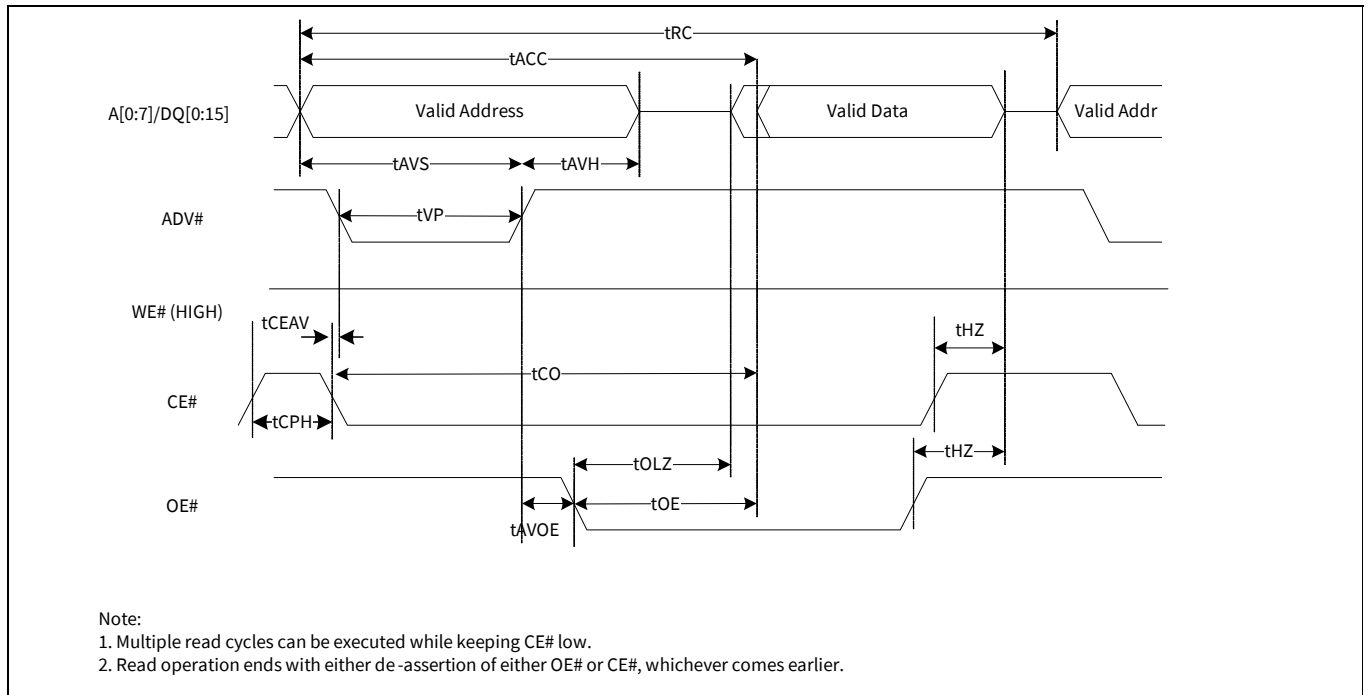
**Table 18** Asynchronous SRAM timing parameters

Parameter <sup>[8]</sup>	Description	Min	Max	Units
-	SRAM interface bandwidth	-	61.5	MBps
tRC	Read cycle time	32.5	-	ns
tAA	Address to data valid	-	30	ns
tAOS	Address to OE# LOW setup time	7	-	ns
tOH	Data output hold from address change	3	-	ns
tOHH	OE# HIGH hold time	7.5	-	ns
tOHC	OE# HIGH to CE# HIGH	2	-	ns
tOE	OE# LOW to data valid	-	25	ns
tOLZ	OE# LOW to LOW-Z	0	-	ns
tWC	Write cycle time	30	-	ns
tCW	CE# LOW to write end	30	-	ns
tAW	Address valid to write end	30	-	ns
tAS	Address setup to write start	7	-	ns
tAH	Address hold time from CE# or WE#	2	-	ns
tWP	WE# pulse width	20	-	ns
tWPH	WE# HIGH time	10	-	ns
tCPH	CE# HIGH time	10	-	ns
tDS	Data setup to write end	7	-	ns
tDH	Data hold to write end	2	-	ns
tWHZ	Write to DQ HIGH-Z output	-	22.5	ns
tOEZ	OE# HIGH to DQ HIGH-Z output	-	22.5	ns
tOW	End of write to LOW-Z output	0	-	ns

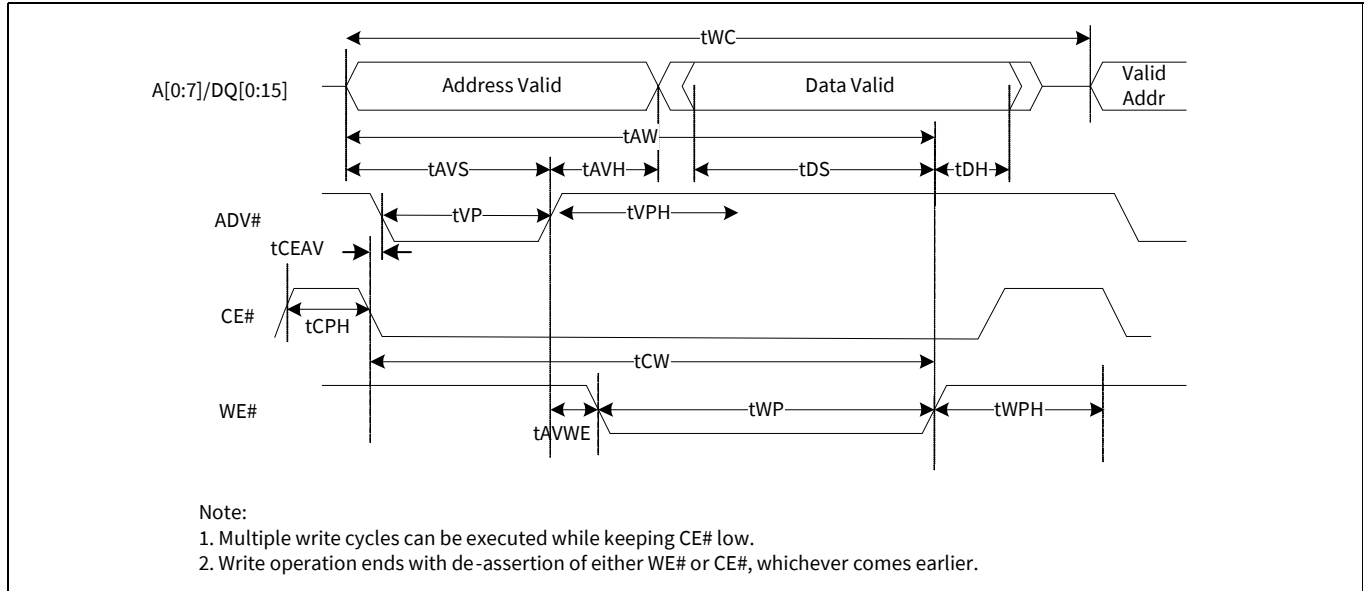
**Note**

8. All parameters guaranteed by design and validated through characterization.

### 21.5 ADMux timing for asynchronous access



**Figure 18 ADMux asynchronous random read**



**Figure 19 ADMux asynchronous random write**

## AC timing parameters

**Table 19 Asynchronous ADMux timing parameters**

Parameter <sup>[9]</sup>	Description	Min	Max	Units	Notes
<b>ADMux asynchronous READ access timing parameters</b>					
tRC	Read cycle time (address valid to address valid)	54.5	–	ns	This parameter is dependent on when the P-port processors deasserts OE#
tACC	Address valid to data valid	–	32	ns	–
tCO	CE# assert to data valid	–	34.5	ns	–
tAVOE	ADV# deassert to OE# assert	2	–	ns	–
tOLZ	OE# assert to data LOW-Z	0	–	ns	–
tOE	OE# assert to data valid	–	25	ns	–
tHZ	Read cycle end to data HIGH-Z	–	22.5	ns	–
<b>ADMux asynchronous WRITE access timing parameters</b>					
tWC	Write cycle time (Address Valid to Address Valid)	–	52.5	ns	–
tAW	Address valid to write end	30	–	ns	–
tCW	CE# assert to write end	30	–	ns	–
tAVWE	ADV# deassert to WE# assert	2	–	ns	–
tWP	WE# LOW pulse width	20	–	ns	–
tWPH	WE# HIGH pulse width	10	–	ns	–
tDS	Data valid setup to WE# deassert	18	–	ns	–
tDH	Data valid hold from WE# deassert	2	–	ns	–
<b>ADMux asynchronous common READ/WRITE access timing parameters</b>					
tAVS	Address valid setup to ADV# deassert	5	–	ns	–
tAVH	Address valid hold from ADV# deassert	2	–	ns	–
tVP	ADV# LOW pulse width	7.5	–	ns	–
tCPH	CE# HIGH pulse width	10	–	ns	–
tVPH	ADV# HIGH pulse width	15	–	ns	–
tCEAV	CE# assert to ADV# assert	0	–	ns	–

**Note**

9. All parameters guaranteed by design and validated through characterization.

## 21.6 Synchronous ADMux timing

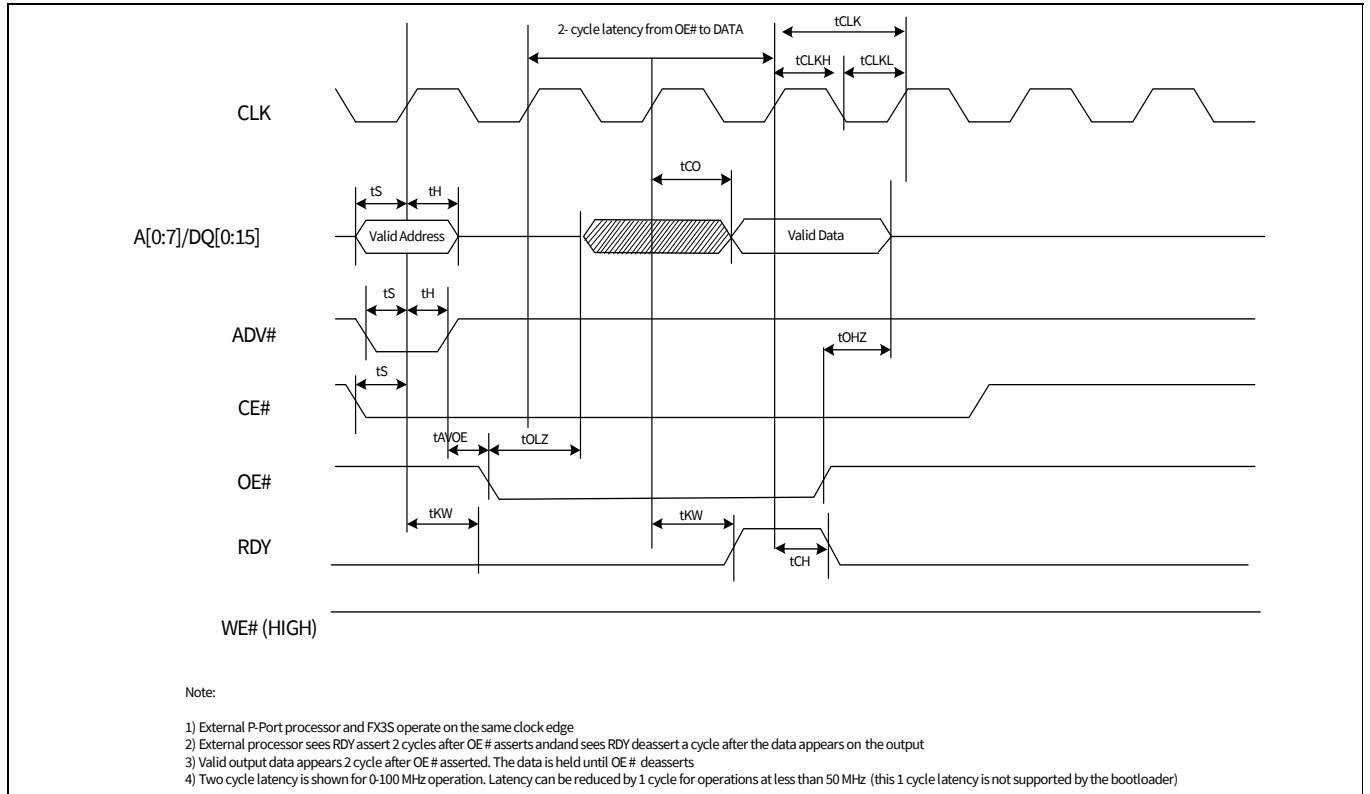


Figure 20 Synchronous ADMux interface – Read cycle timing

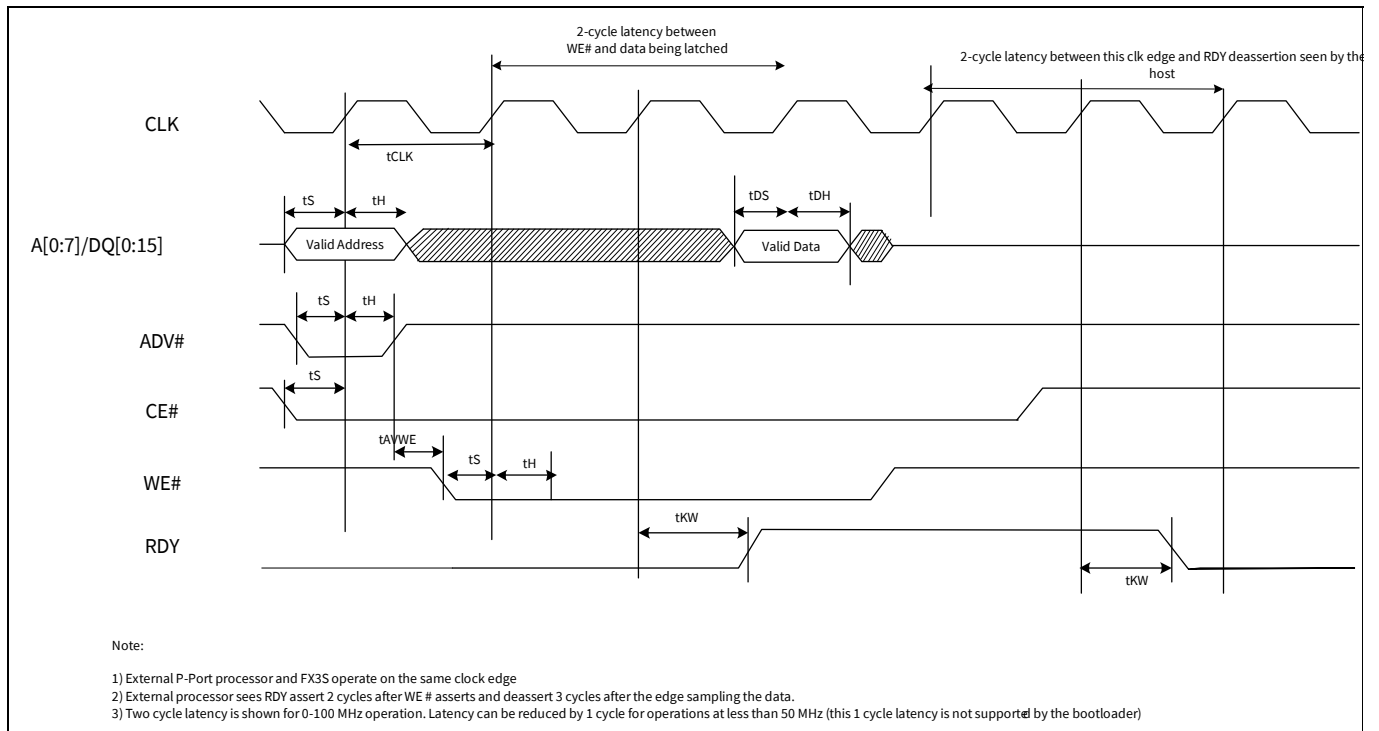


Figure 21 Synchronous ADMux interface – Write cycle timing

AC timing parameters

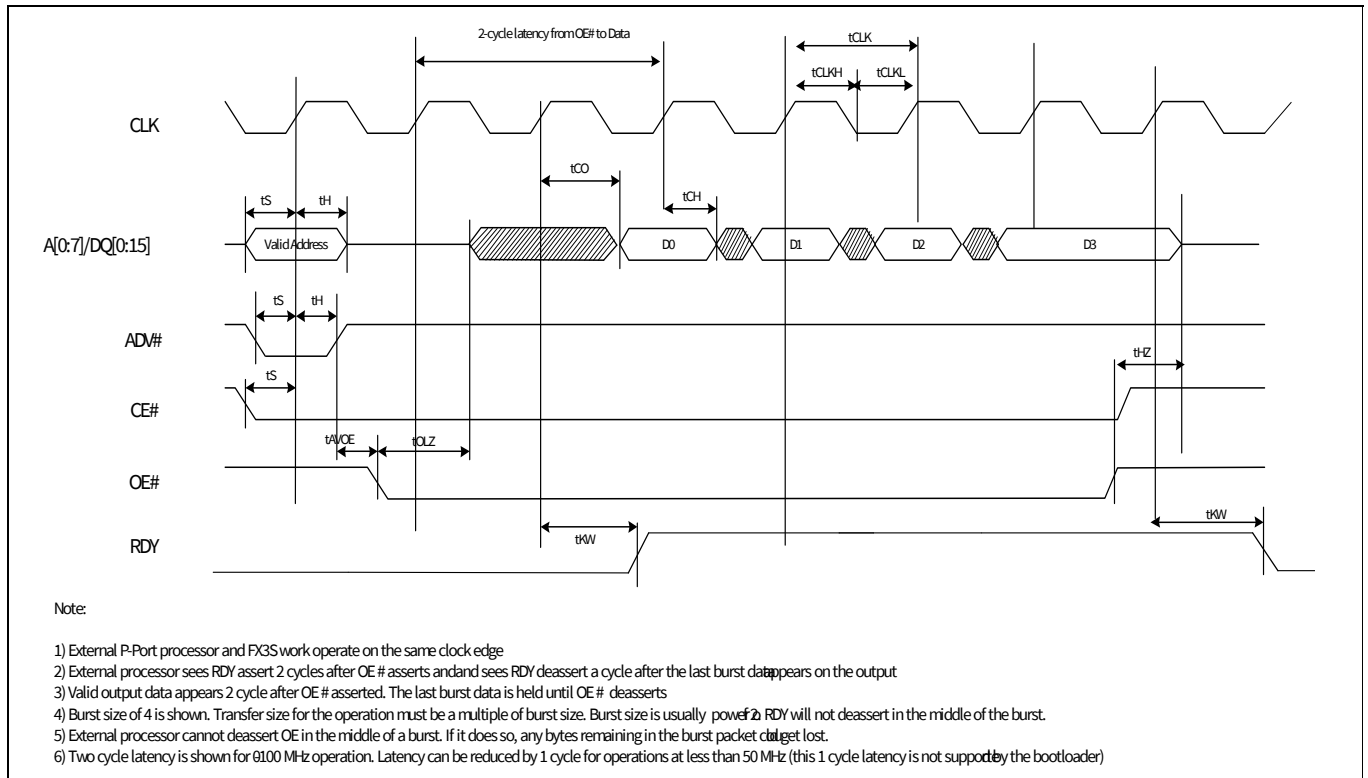


Figure 22 Synchronous ADMux interface – Burst read timing

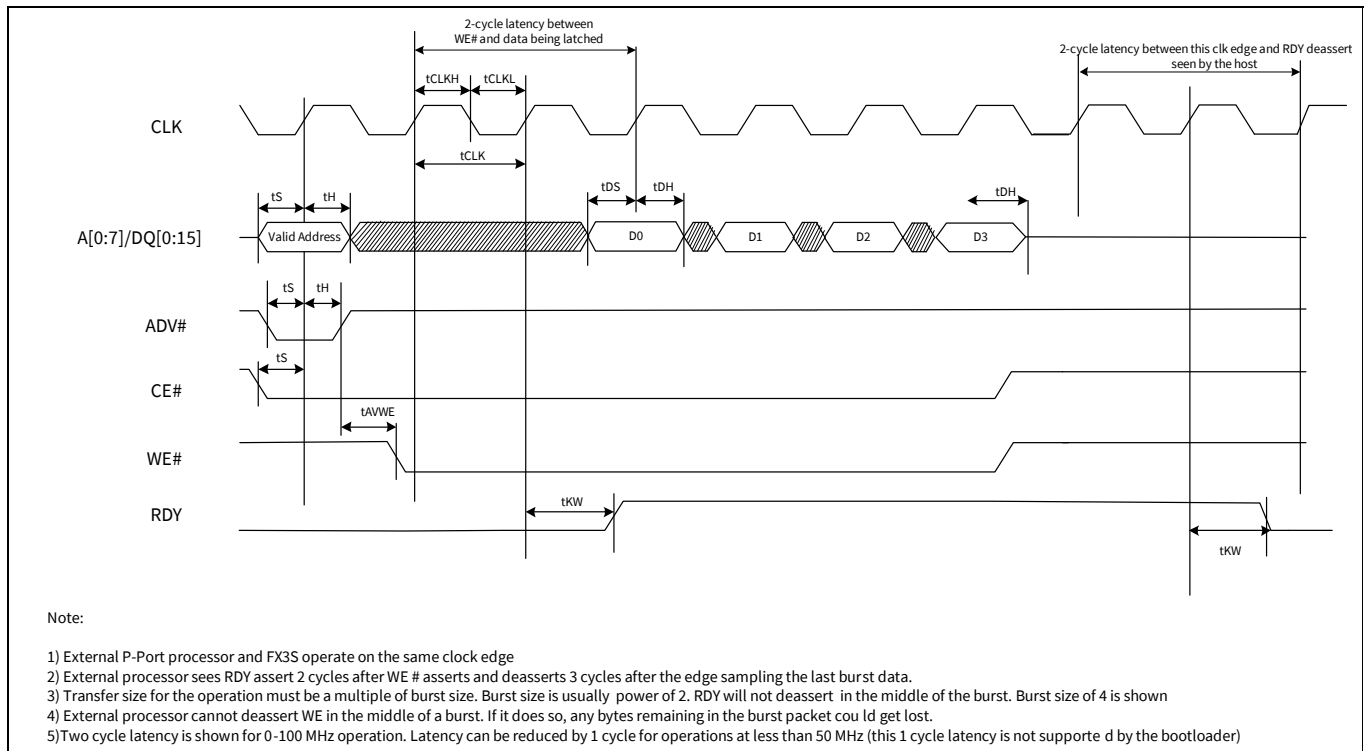


Figure 23 Sync ADMux interface – Burst write timing

## AC timing parameters

**Table 20 Synchronous ADMux timing parameters**

Parameter <sup>[10]</sup>	Description	Min	Max	Unit
FREQ	Interface clock frequency	–	100	MHz
tCLK	Clock period	10	–	ns
tCLKH	Clock HIGH time	4	–	ns
tCLKL	Clock LOW time	4	–	ns
tS	CE#/WE#/DQ setup time	2	–	ns
tH	CE#/WE#/DQ hold time	0.5	–	ns
tCH	Clock to data output hold time	0	–	ns
tDS	Data input setup time	2	–	ns
tDH	Clock to data input hold	0.5	–	ns
tAVDOE	ADV# HIGH to OE# LOW	0	–	ns
tAVDWE	ADV# HIGH to WE# LOW	0	–	ns
tHZ	CE# HIGH to Data HIGH-Z	–	8	ns
tOHZ	OE# HIGH to Data HIGH-Z	–	8	ns
tOLZ	OE# LOW to Data LOW-Z	0	–	ns
tKW	Clock to RDY valid	–	8	ns

**Note**

10.All parameters guaranteed by design and validated through characterization.

AC timing parameters

## 21.7 Slave FIFO interface

### 21.7.1 Synchronous slave FIFO sequence description

- FIFO address is stable and SLCS is asserted
- FLAG indicates FIFO not empty status
- SLOE is asserted. SLOE is an output-enable only, whose sole function is to drive the data bus.
- SLRD is asserted

The FIFO pointer is updated on the rising edge of the PCLK, while the SLRD is asserted. This starts the propagation of data from the newly addressed location to the data bus. After a propagation delay of  $t_{co}$  (measured from the rising edge of PCLK), the new data value is present. N is the first data value read from the FIFO. To have data on the FIFO data bus, SLOE must also be asserted.

The same sequence of events is shown for a burst read.

#### FLAG usage:

The FLAG signals are monitored for flow control by the external processor. FLAG signals are outputs from FX3S that may be configured to show empty, full, or partial status for a dedicated thread or the current thread that is addressed.

#### Socket switching delay (Tssd):

The socket-switching delay is measured from the time EPSWITCH# is asserted by the master, with the new socket address on the address bus, to the time the Current\_Thread\_DMA\_Ready flag is asserted. For the Producer socket, the flag is asserted when it is ready to receive data in the DMA buffer. For the Consumer socket, the flag is asserted when it is ready to drive data out of the DMA buffer. For a synchronous slave FIFO interface, the switching delay is measured in the number of GPIF interface clock cycles; for an asynchronous slave FIFO interface, in PIB clock cycles. This is applicable only for the 5-bit Slave FIFO interface; there is no socket-switching delay in FX3's 2-bit Slave FIFO interface, which makes use of thread switching in the GPIF™ II state machine.

**Note** For burst mode, the SLRD# and SLOE# are asserted during the entire duration of the read. When SLOE# is asserted, the data bus is driven (with data from the previously addressed FIFO). For each subsequent rising edge of PCLK, while the SLRD# is asserted, the FIFO pointer is incremented and the next data value is placed on the data bus.

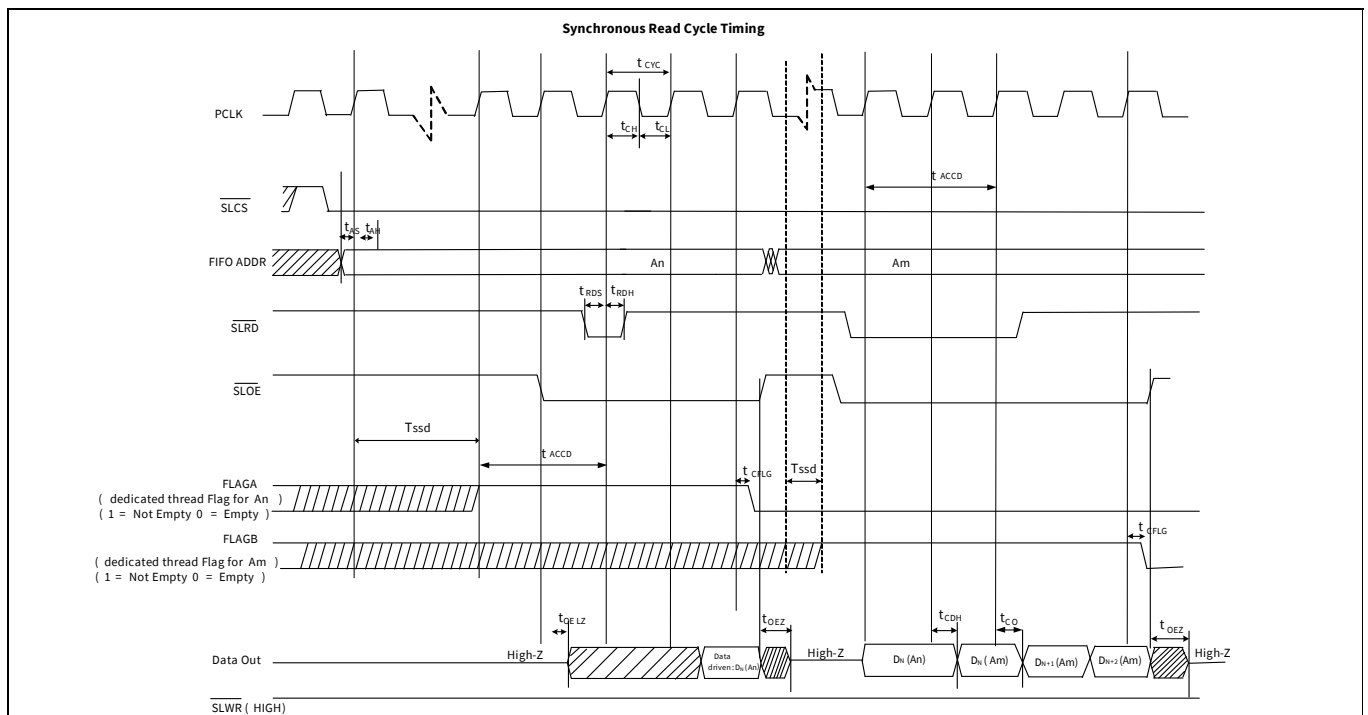


Figure 24 Synchronous slave FIFO read mode

### 21.7.2 Synchronous slave FIFO write sequence description

- FIFO address is stable and the signal SLCS# is asserted
- External master or peripheral outputs the data to the data bus
- SLWR# is asserted
- While the SLWR# is asserted, data is written to the FIFO and on the rising edge of the PCLK, the FIFO pointer is incremented
- The FIFO flag is updated after a delay of  $t_{WFLG}$  from the rising edge of the clock

The same sequence of events is also shown for burst write

**Note** For the burst mode, SLWR# and SLCS# are asserted for the entire duration, during which all the required data values are written. In this burst write mode, after the SLWR# is asserted, the data on the FIFO data bus is written to the FIFO on every rising edge of PCLK. The FIFO pointer is updated on each rising edge of PCLK.

**Short Packet:** A short packet can be committed to the USB host by using the PKTEND#. The external device or processor should be designed to assert the PKTEND# along with the last word of data and SLWR# pulse corresponding to the last word. The FIFOADDR lines must be held constant during the PKTEND# assertion.

**Zero-Length Packet:** The external device or processor can signal a Zero-Length Packet (ZLP) to FX3S simply by asserting PKTEND#, without asserting SLWR#. SLCS# and address must be driven as shown in [Figure 25](#).

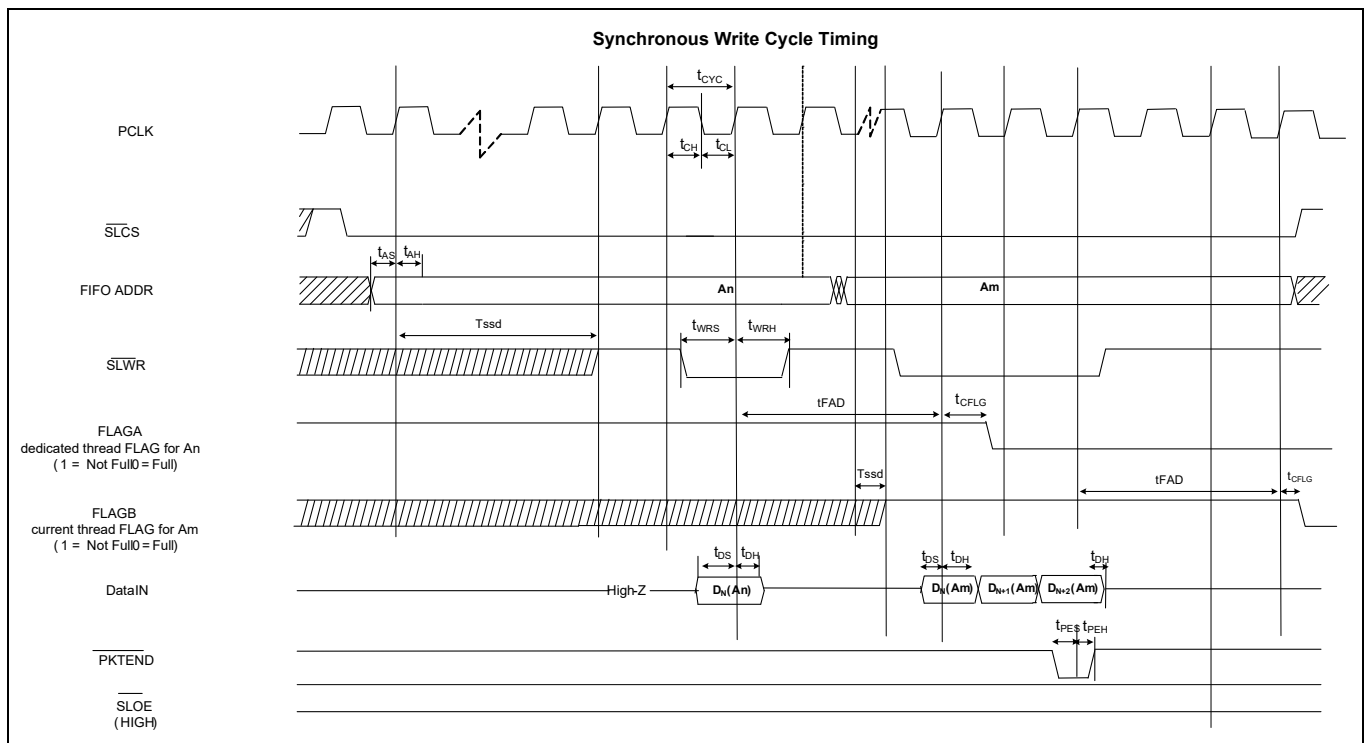


Figure 25 Synchronous slave FIFO write mode

## AC timing parameters

**Table 21 Synchronous slave FIFO parameters**

Parameter <sup>[11]</sup>	Description	Min	Max	Units
FREQ	Interface clock frequency	–	100	MHz
tCYC	Clock period	10	–	ns
tCH	Clock high time	4	–	ns
tCL	Clock low time	4	–	ns
tRDS	SLRD# to CLK setup time	2	–	ns
tRDH	SLRD# to CLK hold time	0.5	–	ns
tWRS	SLWR# to CLK setup time	2	–	ns
tWRH	SLWR# to CLK hold time	0.5	–	ns
tCO	Clock to valid data	–	7	ns
tDS	Data input setup time	2	–	ns
tDH	CLK to data input hold	0.5	–	ns
tAS	Address to CLK setup time	2	–	ns
tAH	CLK to address hold time	0.5	–	ns
tOELZ	SLOE# to data low-Z	0	–	ns
tCFLG	CLK to flag output propagation delay	–	8	ns
tOEZ	SLOE# deassert to Data Hi Z	–	8	ns
tPES	PKTEND# to CLK setup	2	–	ns
tPEH	CLK to PKTEND# hold	0.5	–	ns
tCDH	CLK to data output hold	2	–	ns
tSSD	Socket switching delay	2	68	Clock cycles
tACCD	Latency from SLRD# to Data	2	2	Clock cycles
tFAD	Latency from SLWR# to FLAG	3	3	Clock cycles

**Note** Three-cycle latency from ADDR to DATA/FLAGS

**Note**

11.All parameters guaranteed by design and validated through characterization.

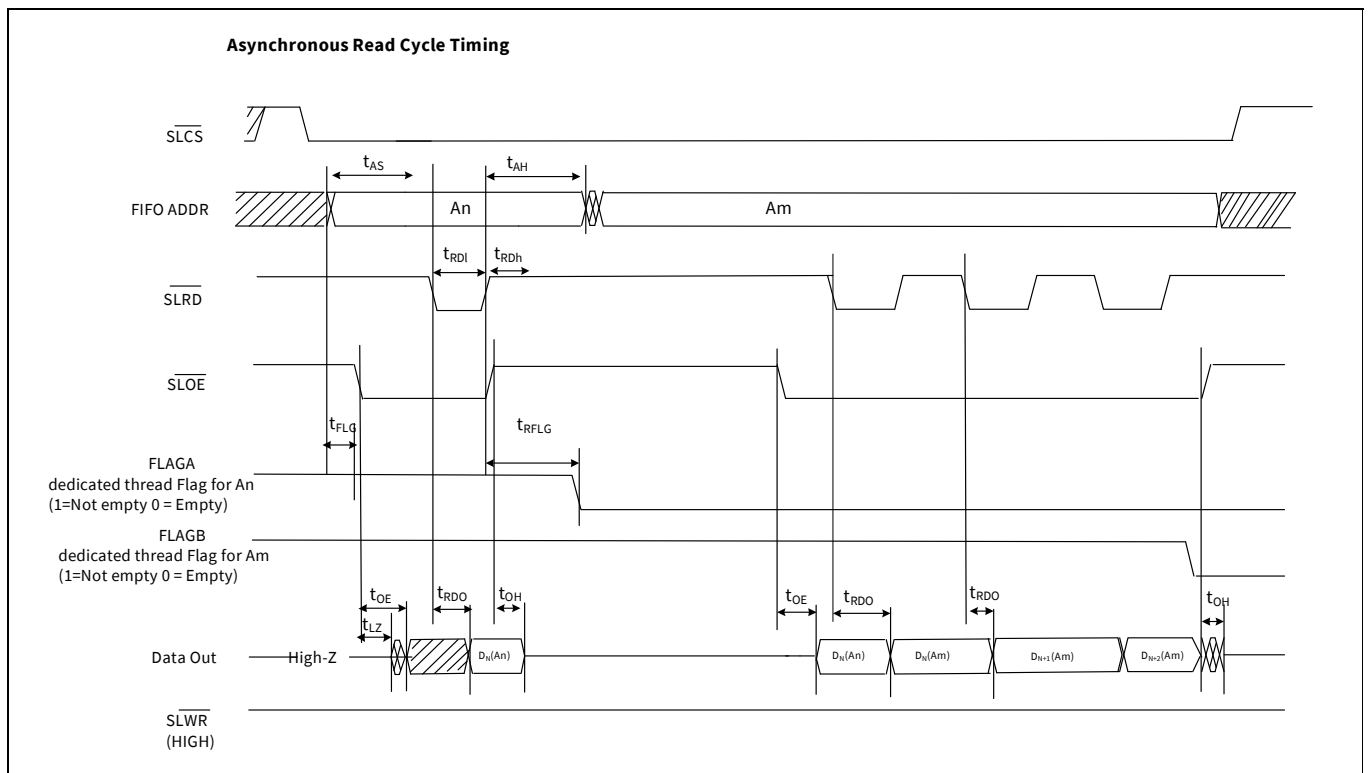
## 21.8 Asynchronous slave FIFO read sequence description

- FIFO address is stable and the SLCS# signal is asserted.
- SLOE# is asserted. This results in driving the data bus.
- SLRD # is asserted.
- Data from the FIFO is driven after assertion of SLRD#. This data is valid after a propagation delay of  $t_{RDO}$  from the falling edge of SLRD#.
- FIFO pointer is incremented on deassertion of SLRD#

In **Figure 26**, data N is the first valid data read from the FIFO. For data to appear on the data bus during the read cycle, SLOE# must be in an asserted state. SLRD# and SLOE# can also be tied.

The same sequence of events is also shown for a burst read.

**Note** In the burst read mode, during SLOE# assertion, the data bus is in a driven state (data is driven from a previously addressed FIFO). After assertion of SLRD# data from the FIFO is driven on the data bus (SLOE# must also be asserted). The FIFO pointer is incremented after deassertion of SLRD#.



**Figure 26** Asynchronous slave FIFO read mode

## 21.9 Asynchronous slave FIFO write sequence description

- FIFO address is driven and SLCS# is asserted
- SLWR# is asserted. SLCS# must be asserted with SLWR# or before SLWR# is asserted
- Data must be present on the tWRS bus before the deasserting edge of SLWR#
- Deassertion of SLWR# causes the data to be written from the data bus to the FIFO, and then the FIFO pointer is incremented
- The FIFO flag is updated after the tWFLG from the deasserting edge of SLWR.

The same sequence of events is shown for a burst write.

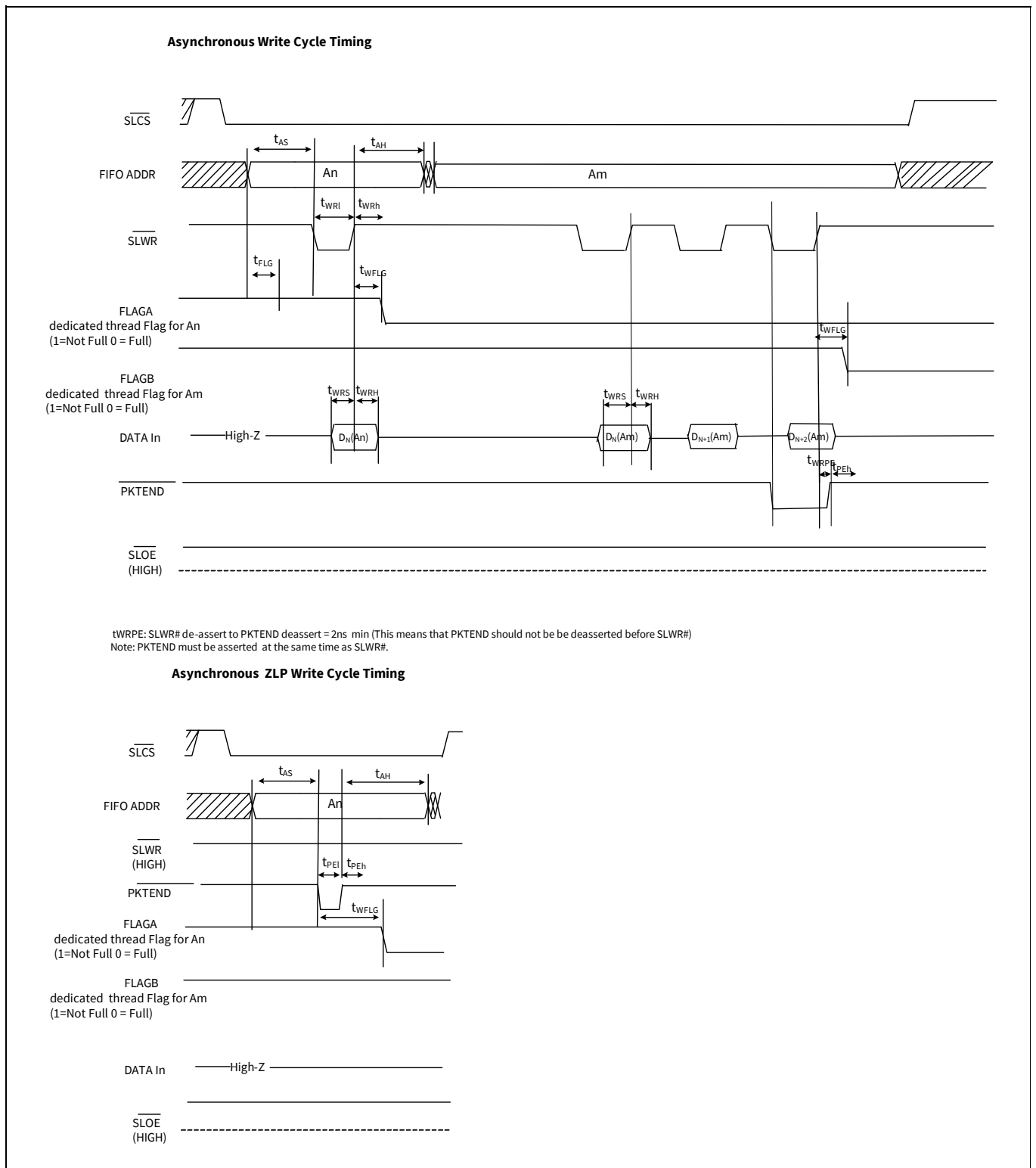
Note that in the burst write mode, after SLWR# deassertion, the data is written to the FIFO, and then the FIFO pointer is incremented.

**Short Packet:** A short packet can be committed to the USB host by using the PKTEND#. The external device or processor should be designed to assert the PKTEND# along with the last word of data and SLWR# pulse corresponding to the last word. The FIFOADDR lines must be held constant during the PKTEND# assertion.

**Zero-Length Packet:** The external device or processor can signal a zero-length packet (ZLP) to FX3S simply by asserting PKTEND#, without asserting SLWR#. SLCS# and the address must be driven as shown in [Figure 27](#).

**FLAG Usage:** The FLAG signals are monitored by the external processor for flow control. FLAG signals are FX3S outputs that can be configured to show empty, full, and partial status for a dedicated address or the current address.

AC timing parameters



**Figure 27 Asynchronous slave FIFO write mode**

## AC timing parameters

**Table 22** Asynchronous slave FIFO parameters

Parameter <sup>[12]</sup>	Description	Min	Max	Units
tRDI	SLRD# low	20	–	ns
tRDh	SLRD# high	10	–	ns
tAS	Address to SLRD#/SLWR# setup time	7	–	ns
tAH	SLRD#/SLWR#/PKTEND to address hold time	2	–	ns
tRFLG	SLRD# to FLAGS output propagation delay	–	35	ns
tFLG	ADDR to FLAGS output propagation delay	–	22.5	
tRDO	SLRD# to data valid	–	25	ns
tOE	OE# low to data valid	–	25	ns
tLZ	OE# low to data low-Z	0	–	ns
tOH	SLOE# deassert data output hold	–	22.5	ns
tWRI	SLWR# low	20	–	ns
tWRh	SLWR# high	10	–	ns
tWRS	Data to SLWR# setup time	7	–	ns
tWRH	SLWR# to Data Hold time	2	–	ns
tWFLG	SLWR#/PKTEND to Flags output propagation delay	–	35	ns
tPEI	PKTEND low	20	–	ns
tPEh	PKTEND high	7.5	–	ns
tWRPE	SLWR# deassert to PKTEND deassert	2	–	ns

**Note**

12.All parameters guaranteed by design and validated through characterization.

AC timing parameters

## 21.10 Storage port timing

The S0-Port and S1-Port support the MMC Specification Version 4.41 and SD Specification Version 3.0. [Table 23](#) lists the timing parameters for S-Port of the FX3S device.

**Table 23 S-Port timing parameters**

Parameter <sup>[13]</sup>	Description	Min	Max	Units
<b>MMC-20</b>				
tSDIS CMD	Host input setup time for CMD	4.8	–	ns
tSDIS DAT	Host input setup time for DAT	4.8	–	ns
tSDIH CMD	Host input hold time for CMD	4.4	–	ns
tSDIH DAT	Host input hold time for DAT	4.4	–	ns
tSDOS CMD	Host output setup time for CMD	5	–	ns
tSDOS DAT	Host output setup time for DAT	5	–	ns
tSDOH CMD	Host output hold time for CMD	5	–	ns
tSDOH DAT	Host output hold time for DAT	5	–	ns
tSCLKR	Clock rise time	–	2	ns
tSCLKF	Clock fall time	–	2	ns
tSDCK	Clock cycle time	50	–	ns
SDFREQ	Clock frequency	–	20	MHz
tSDCLKOD	Clock duty cycle	40	60	%
<b>MMC-26</b>				
tSDIS CMD	Host input setup time for CMD	10	–	ns
tSDIS DAT	Host input setup time for DAT	10	–	ns
tSDIH CMD	Host input hold time for CMD	9	–	ns
tSDIH DAT	Host input hold time for DAT	9	–	ns
tSDOS CMD	Host output setup time for CMD	3	–	ns
tSDOS DAT	Host output setup time for DAT	3	–	ns
tSDOH CMD	Host output hold time for CMD	3	–	ns
tSDOH DAT	Host output hold time for DAT	3	–	ns
tSCLKR	Clock rise time	–	2	ns
tSCLKF	Clock fall time	–	2	ns
tSDCK	Clock cycle time	38.5	–	ns
SDFREQ	Clock frequency	–	26	MHz
tSDCLKOD	Clock duty cycle	40	60	%
<b>MC-HS</b>				
tSDIS CMD	Host input setup time for CMD	4	–	ns
tSDIS DAT	Host input setup time for DAT	4	–	ns
tSDIH CMD	Host input hold time for CMD	3	–	ns
tSDIH DAT	Host input hold time for DAT	3	–	ns
tSDOS CMD	Host output setup time for CMD	3	–	ns
tSDOS DAT	Host output setup time for DAT	3	–	ns

### Note

13.All parameters guaranteed by design and validated through characterization.

## AC timing parameters

**Table 23** S-Port timing parameters (continued)

Parameter <sup>[13]</sup>	Description	Min	Max	Units
tSDOH CMD	Host output hold time for CMD	3	–	ns
tSDOH DAT	Host output hold time for DAT	3	–	ns
tSCLKR	Clock rise time	–	2	ns
tSCLKF	Clock fall time	–	2	ns
tSDCK	Clock cycle time	19.2	–	ns
SDFREQ	Clock frequency	–	52	MHz
tSDCLKOD	Clock duty cycle	40	60	%

**MMC-DDR52**

tSDIS CMD	Host input setup time for CMD	4	–	ns
tSDIS DAT	Host input setup time for DAT	0.56	–	ns
tSDIH CMD	Host input hold time for CMD	3	–	ns
tSDIH DAT	Host input hold time for DAT	2.58	–	ns
tSDOS CMD	Host output setup time for CMD	3	–	ns
tSDOS DAT	Host output setup time for DAT	2.5	–	ns
tSDOH CMD	Host output hold time for CMD	3	–	ns
tSDOH DAT	Host output hold time for DAT	2.5	–	ns
tSCLKR	Clock rise time	–	2	ns
tSCLKF	Clock fall time	–	2	ns
tSDCK	Clock cycle time	19.2	–	ns
SDFREQ	Clock frequency	–	52	MHz
tSDCLKOD	Clock duty cycle	45	55	%

**SD-Default Speed (SDR12)**

tSDIS CMD	Host input setup time for CMD	24	–	ns
tSDIS DAT	Host input setup time for DAT	24	–	ns
tSDIH CMD	Host input hold time for CMD	2.5	–	ns
tSDIH DAT	Host input hold time for DAT	2.5	–	ns
tSDOS CMD	Host output setup time for CMD	5	–	ns
tSDOS DAT	Host output setup time for DAT	5	–	ns
tSDOH CMD	Host output hold time for CMD	5	–	ns
tSDOH DAT	Host output hold time for DAT	5	–	ns
tSCLKR	Clock rise time	–	2	ns
tSCLKF	Clock fall time	–	2	ns
tSDCK	Clock cycle time	40	–	ns
SDFREQ	Clock frequency	–	25	MHz
tSDCLKOD	Clock duty cycle	40	60	%

**SD-High-Speed (SDR25)**

tSDIS CMD	Host input setup time for CMD	4	–	ns
tSDIS DAT	Host input setup time for DAT	4	–	ns

**Note**

13.All parameters guaranteed by design and validated through characterization.

## AC timing parameters

**Table 23** S-Port timing parameters (continued)

Parameter <sup>[13]</sup>	Description	Min	Max	Units
tSDIH CMD	Host input hold time for CMD	2.5	–	ns
tSDIH DAT	Host input hold time for DAT	2.5	–	ns
tSDOS CMD	Host output setup time for CMD	6	–	ns
tSDOS DAT	Host output setup time for DAT	6	–	ns
tSDOH CMD	Host output hold time for CMD	2	–	ns
tSDOH DAT	Host output hold time for DAT	2	–	ns
tSCLKR	Clock rise time	–	2	ns
tSCLKF	Clock fall time	–	2	ns
tSDCK	Clock cycle time	20	–	ns
SDFREQ	Clock frequency	–	50	MHz
tSDCLKOD	Clock duty cycle	40	60	%
<b>SD-SDR50</b>				
tSDIS CMD	Host input setup time for CMD	1.5	–	ns
tSDIS DAT	Host input setup time for DAT	1.5	–	ns
tSDIH CMD	Host input hold time for CMD	2.5	–	ns
tSDIH DAT	Host input hold time for DAT	2.5	–	ns
tSDOS CMD	Host output setup time for CMD	3	–	ns
tSDOS DAT	Host output setup time for DAT	3	–	ns
tSDOH CMD	Host output hold time for CMD	0.8	–	ns
tSDOH DAT	Host output hold time for DAT	0.8	–	ns
tSCLKR	Clock rise time	–	2	ns
tSCLKF	Clock fall time	–	2	ns
tSDCK	Clock cycle time	10	–	ns
SDFREQ	Clock frequency	–	100	MHz
tSDCLKOD	Clock duty cycle	40	60	%
<b>SD-DDR50</b>				
tSDIS CMD	Host input setup time for CMD	4	–	ns
tSDIS DAT	Host input setup time for DAT	0.92	–	ns
tSDIH CMD	Host input hold time for CMD	2.5	–	ns
tSDIH DAT	Host input hold time for DAT	2.5	–	ns
tSDOS CMD	Host output setup time for CMD	6	–	ns
tSDOS DAT	Host output setup time for DAT	3	–	ns
tSDOH CMD	Host output hold time for CMD	0.8	–	ns
tSDOH DAT	Host output hold time for DAT	0.8	–	ns
tSCLKR	Clock rise time	–	2	ns
tSCLKF	Clock fall time	–	2	ns
tSDCK	Clock cycle time	20	–	ns

**Note**

13.All parameters guaranteed by design and validated through characterization.

AC timing parameters

**Table 23 S-Port timing parameters (continued)**

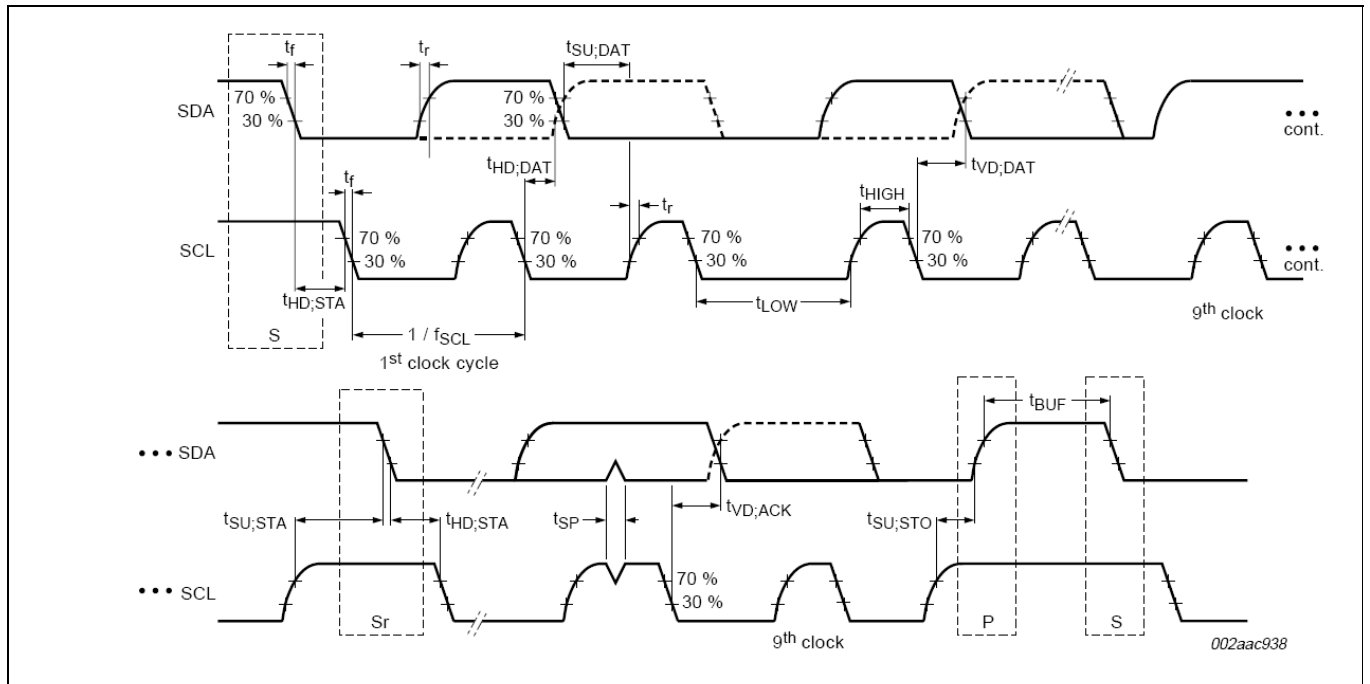
Parameter <sup>[13]</sup>	Description	Min	Max	Units
SDFREQ	Clock frequency	–	50	MHz
tSDCLKOD	Clock duty cycle	45	55	%

**Note**

13.All parameters guaranteed by design and validated through characterization.

**21.11 Serial peripherals timing**

**21.11.1 I<sup>2</sup>C timing**



**Figure 28 I<sup>2</sup>C timing definition**

**Table 24 I<sup>2</sup>C timing parameters**

Parameter <sup>[14]</sup>	Description	Min	Max	Units
<b>I<sup>2</sup>C standard mode parameters</b>				
fSCL	SCL clock frequency	0	100	kHz
tHD:STA	Hold time START condition	4	–	μs
tLOW	LOW period of the SCL	4.7	–	μs
tHIGH	HIGH period of the SCL	4	–	μs
tSU:STA	Setup time for a repeated START condition	4.7	–	μs
tHD:DAT	Data hold time	0	–	μs
tSU:DAT	Data setup time	250	–	ns
tr	Rise time of both SDA and SCL signals	–	1000	ns
tf	Fall time of both SDA and SCL signals	–	300	ns

**Note**

14.All parameters guaranteed by design and validated through characterization.

## AC timing parameters

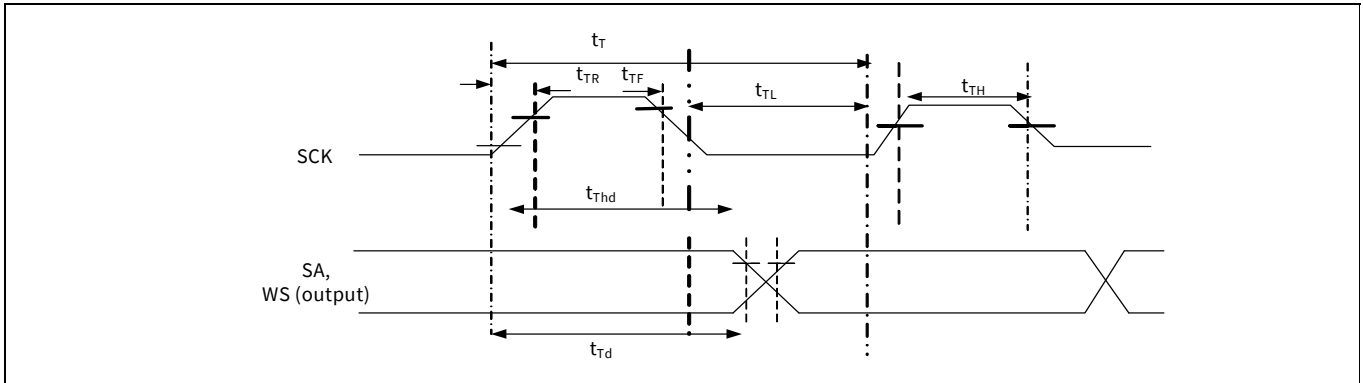
**Table 24** I<sup>2</sup>C timing parameters (continued)

Parameter <sup>[14]</sup>	Description	Min	Max	Units
tSU:STO	Setup time for STOP condition	4	–	μs
tBUF	Bus free time between a STOP and START condition	4.7	–	μs
tVD:DAT	Data valid time	–	3.45	μs
tVD:ACK	Data valid ACK	–	3.45	μs
tSP	Pulse width of spikes that must be suppressed by input filter	n/a	n/a	
<b>I<sup>2</sup>C fast mode parameters</b>				
fSCL	SCL clock frequency	0	400	kHz
tHD:STA	Hold time START condition	0.6	–	μs
tLOW	LOW period of the SCL	1.3	–	μs
tHIGH	HIGH period of the SCL	0.6	–	μs
tSU:STA	Setup time for a repeated START condition	0.6	–	μs
tHD:DAT	Data hold time	0	–	μs
tSU:DAT	Data setup time	100	–	ns
tr	Rise time of both SDA and SCL signals	–	300	ns
tf	Fall time of both SDA and SCL signals	–	300	ns
tSU:STO	Setup time for STOP condition	0.6	–	μs
tBUF	Bus free time between a STOP and START condition	1.3	–	μs
tVD:DAT	Data valid time	–	0.9	μs
tVD:ACK	Data valid ACK	–	0.9	μs
tSP	Pulse width of spikes that must be suppressed by input filter	0	50	ns
<b>I<sup>2</sup>C fast mode plus parameters</b> (Not supported at I2C_VDDQ=1.2 V)				
fSCL	SCL clock frequency	0	1000	kHz
tHD:STA	Hold time START condition	0.26	–	μs
tLOW	LOW period of the SCL	0.5	–	μs
tHIGH	HIGH period of the SCL	0.26	–	μs
tSU:STA	Setup time for a repeated START condition	0.26	–	μs
tHD:DAT	Data hold time	0	–	μs
tSU:DAT	Data setup time	50	–	ns
tr	Rise time of both SDA and SCL signals	–	120	ns
tf	Fall time of both SDA and SCL signals	–	120	ns
tSU:STO	Setup time for STOP condition	0.26	–	μs
tBUF	Bus-free time between a STOP and START condition	0.5	–	μs
tVD:DAT	Data valid time	–	0.45	μs
tVD:ACK	Data valid ACK	–	0.55	μs
tSP	Pulse width of spikes that must be suppressed by input filter	0	50	ns

**Note**

14.All parameters guaranteed by design and validated through characterization.

### 21.11.2 I<sup>2</sup>S timing diagram



**Figure 29** I<sup>2</sup>S transmit cycle

**Table 25** I<sup>2</sup>S timing parameters

Parameter <sup>[15]</sup>	Description	Min	Max	Units
$t_T$	I <sup>2</sup> S transmitter clock cycle	$T_{tr}$	–	ns
$t_{TL}$	I <sup>2</sup> S transmitter cycle LOW period	$0.35 \times T_{tr}$	–	ns
$t_{TH}$	I <sup>2</sup> S transmitter cycle HIGH period	$0.35 \times T_{tr}$	–	ns
$t_{TR}$	I <sup>2</sup> S transmitter rise time	–	$0.15 \times T_{tr}$	ns
$t_{TF}$	I <sup>2</sup> S transmitter fall time	–	$0.15 \times T_{tr}$	ns
$t_{Thd}$	I <sup>2</sup> S transmitter data hold time	0	–	ns
$t_{Td}$	I <sup>2</sup> S transmitter delay time	–	$0.8 \times t_T$	ns

**Note**  $t_T$  is selectable through clock gears. Max  $T_{tr}$  is designed for 96-kHz codec at 32 bits to be 326 ns (3.072 MHz).

**Note**

15.All parameters guaranteed by design and validated through characterization.

### 21.11.3 SPI timing specification

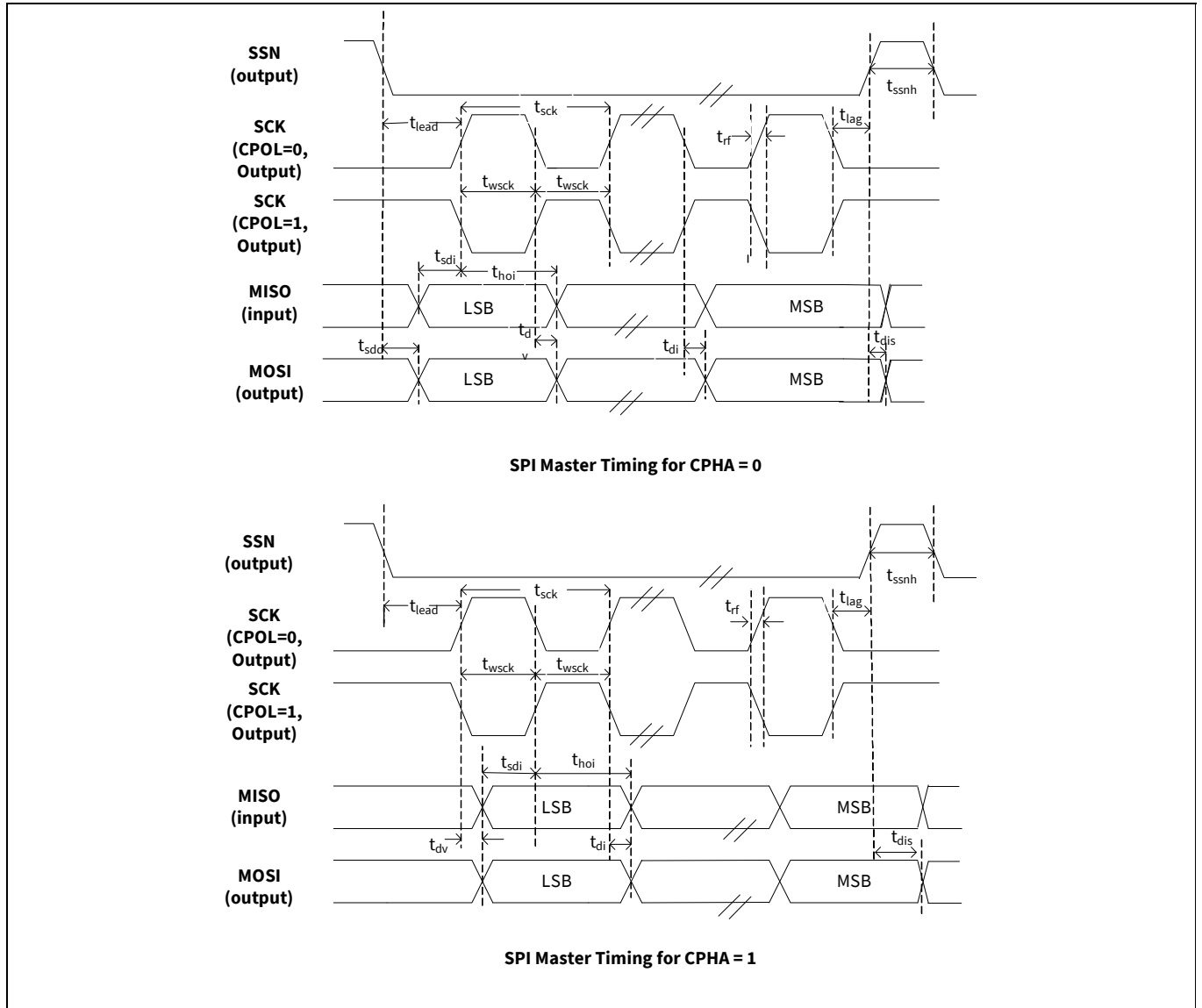


Figure 30 SPI timing

AC timing parameters

**Table 26** SPI timing parameters

Parameter <sup>[16]</sup>	Description	Min	Max	Units
fop	Operating frequency	0	33	MHz
tsck	Cycle time	30	–	ns
twscck	Clock high/low time	13.5	–	ns
tlead	SSN-SCK lead time	$1/2 \text{ tsck}^{[17]} - 5$	$1.5 \text{ tsck}^{[17]} + 5$	ns
tlag	Enable lag time	0.5	$1.5 \text{ tsck}^{[17]} + 5$	ns
trf	Rise/fall time	–	8	ns
tsdd	Output SSN to valid data delay time	–	5	ns
tdv	Output data valid time	–	5	ns
tdi	Output data invalid	0	–	ns
tssnh	Minimum SSN high time	10	–	ns
tsdi	Data setup time input	8	–	ns
thoi	Data hold time input	0	–	ns
tdis	Disable data output on SSN high	0	–	ns

**Notes**

16.All parameters guaranteed by design and validated through characterization.

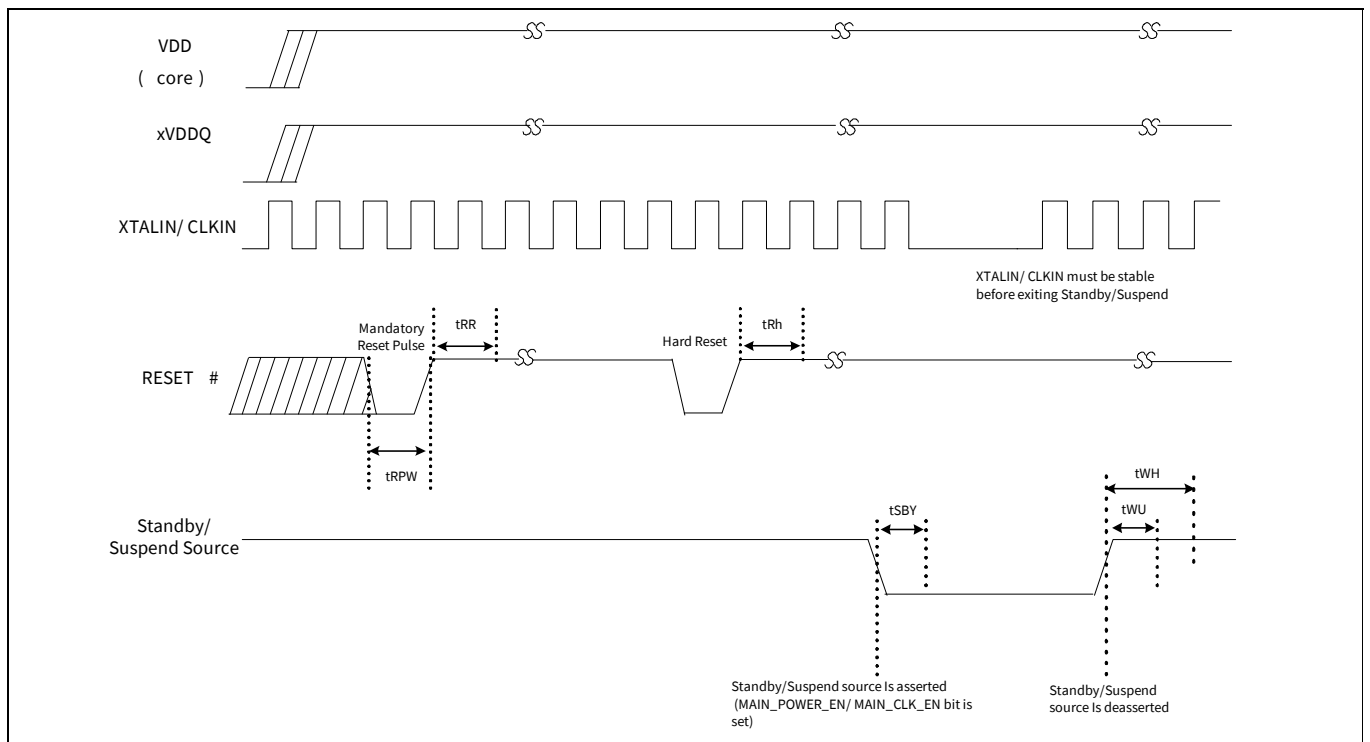
Reset sequence

## 22 Reset sequence

FX3S's hard reset sequence requirements are specified in this section.

**Table 27 Reset and standby timing parameters**

Parameter	Definition	Conditions	Min (ms)	Max (ms)
tRPW	Minimum RESET# pulse width	Clock Input	1	–
		Crystal Input	1	–
tRH	Minimum high on RESET#	–	5	–
tRR	Reset recovery time (after which Boot loader begins firmware download)	Clock Input	1	–
		Crystal Input	5	–
tSBY	Time to enter standby/suspend (from the time MAIN_CLOCK_EN/ MAIN_POWER_EN bit is set)	–	–	1
tWU	Time to wakeup from standby	Clock Input	1	–
		Crystal Input	5	–
tWH	Minimum time before Standby/Suspend source may be reasserted	–	5	–



**Figure 31 Reset sequence**

## 23 Package diagram

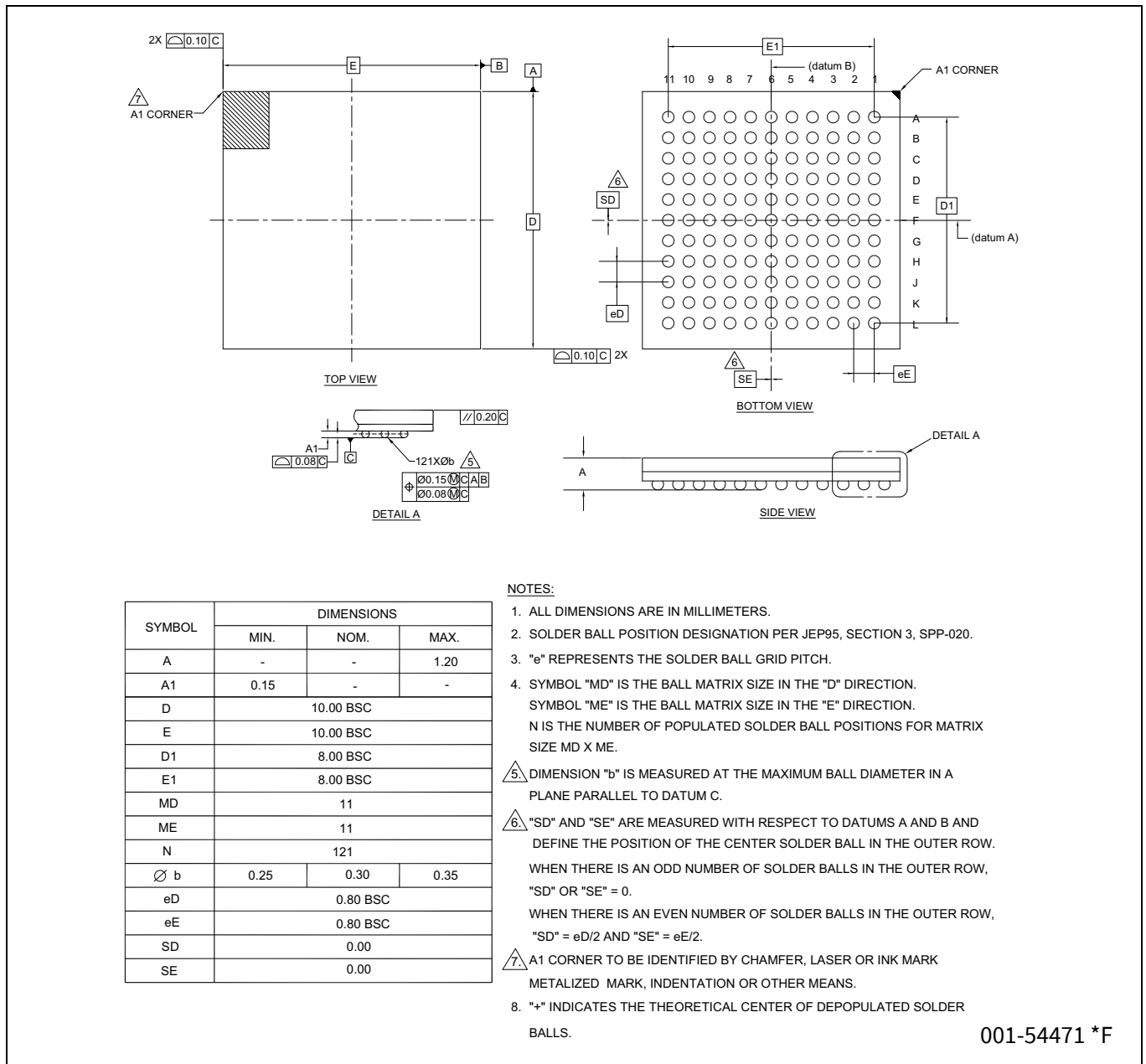


Figure 32 121-ball FBGA (10 × 10 × 1.2 mm (0.30 mm ball diameter)) package outline, 001-54471

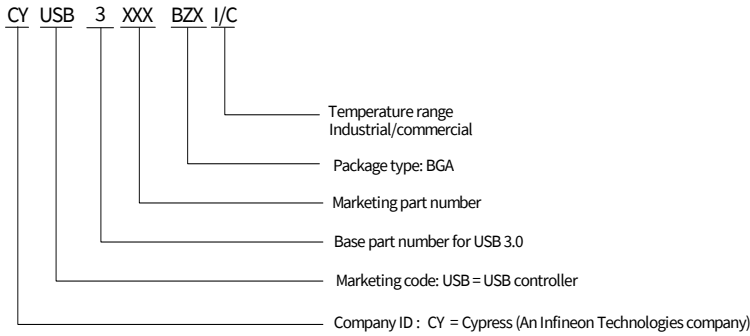
Ordering information

## 24 Ordering information

**Table 28** Device ordering information

Ordering Code	SRAM (KB)	Storage ports	HS-USB OTG	GPIF II data bus width	Package type
CYUSB3035-BZXI	512	2	Yes	16-bit	121-ball BGA
CYUSB3035-BZXC	512	2	Yes	16-bit	121-ball BGA

### 24.1 Ordering code definitions



## 25 Acronyms

**Table 29 Acronyms used in this document**

<b>Acronym</b>	<b>Description</b>
DMA	Direct Memory Access
HNP	Host Negotiation Protocol
MMC	Multimedia Card
MTP	Media Transfer Protocol
PLL	Phase Locked Loop
PMIC	Power Management IC
SD	Secure Digital
SDIO	Secure Digital Input/Output
SLC	Single-Level Cell
SLCS	Slave Chip Select
SLOE	Slave Output Enable
SLRD	Slave Read
SLWR	Slave Write
SPI	Serial Peripheral Interface
SRP	Session Request Protocol
USB	Universal Serial Bus

## 26 Document conventions

### 26.1 Units of measure

Table 30 Units of measure

Symbol	Unit of measure
°C	degree Celsius
Mbps	megabits per second
MBps	megabytes per second
MHz	megahertz
μA	microampere
μs	microsecond
mA	milliampere
ms	millisecond
ns	nanosecond
Ω	ohm
pF	picofarad
V	volt

## 27 Errata

This section describes the errata for Revision D, C, and B of the FX3S. Details include errata trigger conditions, scope of impact, available workaround, and silicon revision applicability. Contact your local Infineon Sales Representative if you have questions.

### Part numbers affected

**Table 31** Part numbers affected

Part number	Device characteristics
CYUSB303x-xxxx	All variants

### EZ-USB™ FX3 SuperSpeed USB qualification status

Product status: Production

### EZ-USB™ FX3 SuperSpeed USB errata summary

The following table defines the errata applicability to available Rev. D EZ-USB™ FX3S SuperSpeed USB Controller family devices.

Items	[Part number]	Silicon revision	Fix status
1. <b>Turning off VIO1 during Normal, Suspend, and Standby modes causes the FX3S to stop working.</b>	CYUSB303x-xxxx	Rev. D, C, B	Workaround provided
2. <b>USB enumeration failure in USB boot mode when FX3S is self-powered.</b>	CYUSB303x-xxxx	Rev. D, C, B	Workaround provided
3. <b>Extra ZLP is generated by the COMMIT action in the GPIF II state.</b>	CYUSB303x-xxxx	Rev. D, C, B	Workaround provided
4. <b>Invalid PID sequence in USB 2.0 ISOC data transfer.</b>	CYUSB303x-xxxx	Rev. D, C, B	Workaround provided
5. <b>USB data transfer errors are seen when ZLP is followed by data packet within same microframe.</b>	CYUSB303x-xxxx	Rev. D, C, B	Workaround provided
6. <b>Bus collision is seen when the I2C block is used as a master in the I2C multi-master configuration.</b>	CYUSB303x-xxxx	Rev. D, C, B	Use FX3S in single-master configuration
7. <b>Low power U1 fast-exit issue with USB3.0 host controller.</b>	CYUSB303x-xxxx	Rev. D, C, B	Workaround provided
8. <b>USB data corruption when operating on hosts with poor link quality.</b>	CYUSB303x-xxxx	Rev. D, C, B	Workaround provided
9. <b>Device treats Rx detect sequence from the USB 3.0 host as a valid U1 exit LFPS burst.</b>	CYUSB303x-xxxx	Rev. D, C, B	Workaround provided
10. <b>I2C data valid (tVD:DAT) specification violation at 400 kHz with a 40/60 duty cycle.</b>	CYUSB303x-xxxx	Rev. D, C, B	No workaround needed
11. <b>FX3S device does not respond correctly to port capability request from host after multiple power cycles.</b>	CYUSB303x-xxxx	Rev. D, C, B	Workaround provided

## Errata

<b>1. Turning off VIO1 during Normal, Suspend, and Standby modes causes the FX3S to stop working.</b>	
Problem definition	Turning off the VIO1 during Normal, Suspend, and Standby modes will cause the FX3S to stop working
Parameters affected	N/A
Trigger condition	This condition is triggered when the VIO1 is turned off during Normal, Suspend, and Standby modes
Scope of impact	FX3S stops working
Workaround	VIO1 must stay on during Normal, Suspend, and Standby modes
Fix status	No fix. Workaround is required.
<b>2. USB enumeration failure in USB boot mode when FX3S is self-powered.</b>	
Problem definition	When FX3S is self-powered and not connected to the USB host, it enters low-power mode and does not wake up when connected to USB host afterwards. This is because the bootloader does not check the VBUS pin on the connector to detect USB connection. It expects that the USB bus is connected to the host when it is powered on.
Parameters affected	N/A
Trigger condition	This condition is triggered when FX3S is self-powered in USB boot mode
Scope of impact	Device does not enumerate
Workaround	Reset the device after connecting to USB host
Fix status	No fix. Workaround is required.
<b>3. Extra ZLP is generated by the COMMIT action in the GPIF II state.</b>	
Problem definition	When COMMIT action is used in a GPIF-II state without IN_DATA action then an extra Zero Length Packet (ZLP) is committed along with the data packets
Parameters affected	N/A
Trigger condition	This condition is triggered when COMMIT action is used in a state without IN_DATA action
Scope of impact	Extra ZLP is generated
Workaround	Use IN_DATA action along with COMMIT action in the same state
Fix status	No fix. Workaround is required.
<b>4. Invalid PID sequence in USB 2.0 ISOC data transfer.</b>	
Problem definition	When the FX3S device is functioning as a high speed USB device with high bandwidth isochronous endpoints, the PID sequence of the ISO data packets is governed solely by the isomult setting. The length of the data packet is not considered while generating the PID sequence during each microframe. For example, even if a short packet is being sent on an endpoint with MULT set to 2; the PID used will be DATA2.
Parameters affected	N/A
Trigger condition	This condition is triggered when high bandwidth ISOC transfer endpoints are used
Scope of impact	ISOC data transfers failure
Workaround	This problem can be worked around by reconfiguring the endpoint with a lower isomult setting prior to sending short packets, and then switching back to the original value
Fix status	No fix. Workaround is required.

<b>5. USB data transfer errors are seen when ZLP is followed by data packet within same microframe.</b>	
Problem definition	Some data transfer errors may be seen if a Zero Length Packet is followed very quickly (within one microframe or 125 $\mu$ s) by another data packet on a burst enabled USB IN endpoint operating at super speed
Parameters affected	N/A
Trigger condition	This condition is triggered in SuperSpeed transfer with ZLPs
Scope of impact	Data failure and lower data speed.
Workaround	The solution is to ensure that some time is allowed to elapse between a ZLP and the next data packet on burst enabled USB IN endpoints. If this cannot be ensured at the data source, the CyU3PDmaChannelSetSuspend() API can be used to suspend the corresponding USB DMA socket on seeing the EOP condition. The channel operation can then be resumed as soon as the suspend callback is received.
Fix status	No fix. Workaround is required.

<b>6. Bus collision is seen when the I<sup>2</sup>C block is used as a master in the I<sup>2</sup>C multi-master configuration.</b>	
Problem definition	When FX3S is used as a master in the I <sup>2</sup> C multi-master configuration, there can be occasional bus collisions
Parameters affected	N/A
Trigger condition	This condition is triggered only when the FX3S I <sup>2</sup> C block operates in Multi-master configuration
Scope of impact	The FX3S I <sup>2</sup> C block can transmit data when the I <sup>2</sup> C bus is not idle leading to bus collision
Workaround	Use FX3S as a single master
Fix status	No fix

<b>7. Low power U1 fast-exit issue with USB3.0 host controller.</b>	
Problem definition	When FX3S device transitions from low power U1 state to U0 state within 5 $\mu$ s after entering U1 state, the device sometimes fails to transition back to U0 state, resulting in USB Reset
Parameters affected	N/A
Trigger condition	This condition is triggered during low power transition mode
Scope of impact	Unexpected USB warm reset during data transfer
Workaround	This problem can be worked around in the FW by disabling LPM (Link Power Management) during data transfer
Fix status	FW workaround is proven and reliable

## Errata

<b>8. USB data corruption when operating on hosts with poor link quality.</b>	
Problem definition	If FX3S is operating on a USB 3.0 link with poor signal quality, the device could send corrupted data on any of the IN endpoints (including the control endpoint)
Parameters affected	N/A
Trigger condition	This condition is triggered when the USB3.0 link signal quality is very poor
Scope of impact	Data corruption in any of the IN endpoints (including the control endpoint)
Workaround	The application firmware should perform an error recovery by stalling the endpoint on receiving CYU3P_USBEPSS_RESET_EVT event, and then stop and restart DMA path when the CLEAR_FEATURE request is received. Note: SDK versions 1.3.3 and above internally manages the DMA transfers and performs the endpoint reset when potential error conditions are seen. For more details in application firmware, see the GpiftoUsb example available with SDK
Fix status	FW workaround is proven and reliable

<b>9. Device treats Rx detect sequence from the USB 3.0 host as a valid U1 exit LFPS burst.</b>	
Problem definition	The USB 3.0 PHY in the FX3S device uses an electrical idle detector to determine whether LFPS is being received. The duration for which the receiver does not see an electrical idle condition is timed to detect various LFPS bursts. This implementation causes the device to treat an Rx Detect sequence from the USB host as a valid U1 exit LFPS burst.
Parameters affected	N/A
Trigger condition	This condition is triggered when the USB host is initiating an Rx Detect sequence while the USB 3.0 Link State Machine on the FX3S is in the U1 state. Since the host will only perform Rx Detect sequence in the RX Detect and U2 states, the error condition is seen only in cases where the USB link on the host has moved into the U2 state while the link on FX3S is in the U1 state.
Scope of impact	FX3S moves into Recovery prematurely leading to a Recovery failure followed by Warm Reset and USB re-enumeration. This sequence can repeat multiple times resulting in data transfer failures.
Workaround	FX3S can be configured to transition from U1 to U2 a few microseconds before the host does so. This will ensure that the link will be in U2 on the device side before the host attempts any Rx Detect sequence; thereby preventing a false detection of U1 exit.
Fix status	Workaround is implemented in FX3S SDK library 1.3.4 and above

<b>10. I<sup>2</sup>C data valid (t<sub>VD:DAT</sub>) specification violation at 400 kHz with a 40/60 duty cycle.</b>	
Problem definition	I <sup>2</sup> C Data Valid (t <sub>VD:DAT</sub> ) parameter at 400 kHz with a 40/60 duty cycle is 1.0625 μs, which exceeds the I <sup>2</sup> C specification limit of 0.9 μs.
Parameters affected	N/A
Trigger condition	This violation occurs only at 400 kHz with a 40/60 duty cycle of the I <sup>2</sup> C clock
Scope of impact	Setup time (t <sub>SUDAT</sub> ) is met with a huge margin for the transmitted data for 400 kHz and so t <sub>VD:DAT</sub> violation will not cause any data integrity issues
Workaround	No workaround needed
Fix status	No fix needed

<b>11.FX3S device does not respond correctly to port capability request from host after multiple power cycles.</b>	
Problem definition	During multiple power cycles, sometimes the FX3S device does not respond correctly to the Port Capability request (Link Packet) from the USB Controller. In view of this, FX3S does not get the subsequent Port Configuration request from the USB controller, resulting in SS.Disabled state. The device fails to recover from this state and finally results in enumeration failure.
Parameters affected	N/A
Trigger condition	This condition is triggered when the FX3S provides an incorrect response to the Port Capability request from the host
Scope of impact	Device fails to enumerate after multiple retries
Workaround	Since the host does not send the Port Configuration request to the FX3S device, it causes a Port Configuration request timeout interrupt to be triggered in the device. This interrupt is handled in the FX3 SDK 1.3.4 onwards to generate and signal CY_U3P_US-B_EVENT_LMP_EXCH_FAIL event to the application. This event should be handled in the user application such that it does a USB Interface Block Restart. See the <a href="#">KBA225778</a> for more details and the firmware workaround example project.
Fix status	Suggested firmware work-around is proven and reliable

## Revision history

## Revision history

Document revision	Date	Description of changes
**	2012-12-06	New datasheet.
*A	2013-02-11	Updated <b>Ordering information</b> : Updated part numbers.
*B	2013-06-20	Updated <b>Ordering information</b> : Updated part numbers. Updated to new template.
*C	2013-09-23	Replaced CYUSB3035 with CYUSB303x in all instances across the document. Updated <b>Features</b> : Updated description. Updated <b>Applications</b> : Updated description. Updated <b>Functional overview</b> : Updated description. Updated <b>Storage port (S-Port)</b> : Updated description.
*D	2015-01-07	Updated <b>Functional description</b> : Added “For a complete list of related resources, click <a href="#">here</a> .” at the end. Added <b>More information</b> .
*E	2015-09-18	Updated <b>AC timing parameters</b> : Updated <b>Slave FIFO interface</b> : Updated <b>Synchronous slave FIFO sequence description</b> : Updated description. Updated <b>Figure 24</b> . Updated <b>Synchronous slave FIFO write sequence description</b> : Updated description. Updated <b>Figure 25</b> . Updated <b>Table 21</b> .
*F	2016-01-14	No technical updates. Completing Sunset Review.
*G	2017-05-04	Updated <b>Package diagram</b> : spec 001-54471 – Changed revision from *D to *E. Updated to new template.
*H	2018-02-20	Updated <b>More information</b> : Removed CYUSB3KIT-001 Kit related information. Updated <b>Package diagram</b> : spec 001-54471 – Changed revision from *E to *F. Added <b>Errata</b> .
*I	2018-09-29	Updated <b>Features</b> : Updated description. Updated <b>More information</b> : Updated description. Updated <b>Functional overview</b> : Updated description. Updated <b>USB interface</b> : Removed “EZ-Dtect”. Updated <b>CarKit UART mode</b> : Updated <b>Figure 5</b> .

## Revision history

Document revision	Date	Description of changes
*1 (cont.)	2018-09-29	<p>Updated <b>Other interfaces</b>:  Updated <b>I2S interface</b>:  Updated description.  Updated <b>Boot options</b>:  Updated description.  Updated <b>Power</b>:  Updated description.  Updated <b>Table 6</b>.  Updated <b>Pinouts</b>:  Updated <b>Figure 11</b>.  Updated <b>Pin description</b>:  Updated <b>Table 7</b>.  Updated <b>Table 9</b>.  Updated <b>Electrical specifications</b>:  Updated <b>DC specifications</b>:  Updated <b>Table 11</b>.  Added <b>Table 12</b>.  Added <b>Thermal characteristics</b>.  Updated <b>AC timing parameters</b>:  Added <b>GPIF II lines AC characteristics at 100 MHz</b>.  Added <b>GPIF II PCLK Jitter characteristics</b>.  Updated <b>GPIF II timing</b>:  Updated <b>Table 16</b>:  Changed maximum value of <math>t_{CO}</math> parameter from 8 ns to 7 ns.  Updated <b>Slave FIFO interface</b>:  Updated <b>Synchronous slave FIFO sequence description</b>:  Updated description.  Updated <b>Synchronous slave FIFO write sequence description</b>:  Updated <b>Table 21</b>:  Changed maximum value of <math>t_{CO}</math> parameter from 8 ns to 7 ns.  Updated <b>Errata</b>:  Updated description.  Updated <b>EZ-USB™ FX3 SuperSpeed USB errata summary</b>:  Updated description.  Updated details in “Silicon Revision” column for all items in the table.  Added items “Low Power U1 Fast-Exit Issue with USB3.0 host controller.”,  “USB data corruption when operating on hosts with poor link quality”,  “Device treats Rx Detect sequence from the USB 3.0 host as a valid U1 exit LFPS burst.”, “I<sup>2</sup>C Data Valid (tVD:DAT) specification violation at 400 kHz with a 40/60 duty cycle.” and their corresponding details in the table.  Updated to new template.</p>

## Revision history

Document revision	Date	Description of changes
*J	2018-12-13	<p>Updated <b>Pin description</b>:</p> <p>Updated <b>Table 9</b>.</p> <p>Updated <b>Errata</b>:</p> <p>Updated <b>EZ-USB™ FX3 SuperSpeed USB errata summary</b>:</p> <p>Updated description.</p> <p>Added item “FX3S Device does not respond correctly to Port Capability Request from Host after multiple power cycles.” and its corresponding details in the table.</p> <p>Completing Sunset Review.</p>
*K	2023-03-21	<p>Updated to Infineon template</p> <p>Updated <b>Logic block diagram</b></p> <p>Updated <b>Table 2</b></p> <p>Updated and added a note for <b>Table 8</b></p> <p>Removed obsolete part numbers from <b>Table 28</b></p>

**Trademarks**

All referenced product or service names and trademarks are the property of their respective owners.

**Edition 2023-03-21**

**Published by**

**Infineon Technologies AG  
81726 Munich, Germany**

**© 2023 Infineon Technologies AG.  
All Rights Reserved.**

**Do you have a question about this document?**

**Email:**

[erratum@infineon.com](mailto:erratum@infineon.com)

**Document reference**

**001-84160 Rev. \*K**

**IMPORTANT NOTICE**

The information given in this document shall in no event be regarded as a guarantee of conditions or characteristics ("Beschaffenheitsgarantie").

With respect to any examples, hints or any typical values stated herein and/or any information regarding the application of the product, Infineon Technologies hereby disclaims any and all warranties and liabilities of any kind, including without limitation warranties of non-infringement of intellectual property rights of any third party.

In addition, any information given in this document is subject to customer's compliance with its obligations stated in this document and any applicable legal requirements, norms and standards concerning customer's products and any use of the product of Infineon Technologies in customer's applications.

The data contained in this document is exclusively intended for technically trained staff. It is the responsibility of customer's technical departments to evaluate the suitability of the product for the intended application and the completeness of the product information given in this document with respect to such application.

**WARNINGS**

Due to technical requirements products may contain dangerous substances. For information on the types in question please contact your nearest Infineon Technologies office.

Except as otherwise explicitly approved by Infineon Technologies in a written document signed by authorized representatives of Infineon Technologies, Infineon Technologies' products may not be used in any applications where a failure of the product or any consequences of the use thereof can reasonably be expected to result in personal injury.

## Looking for pricing, stock, or lifecycle information?

Click below to explore more details on WIN SOURCE:

- ⊖ [View CYUSB3031-BZXC on WIN SOURCE](#)
- ⊖ [Infineon Technologies Information](#)

## Optimize Your Supply Chain with WIN SOURCE Solutions

- ✓ Global Sourcing Solution
- ✓ Obsolete Management
- ✓ Cost Control Management
- ✓ Shortage Management
- ✓ Alternative Solution
- ✓ Excess Inventory Management