



**THE DATASHEET OF
CY7C09359AV-9AXC**



3.3 V 4 K/8 K × 18
Synchronous Dual Port Static RAM

Features

- True dual ported memory cells which allow simultaneous access of the same memory location
- Two flow-through/pipelined devices
 - 4 K × 18 organization (CY7C09349AV)
 - 8 K × 18 organization (CY7C09359AV)
- Three modes
 - Flow-through
 - Pipelined
 - Burst
- Pipelined output mode on both ports allows fast 83-MHz operation
- 0.35-micron CMOS for optimum speed/power
- High-speed clock to data access 9 and 12 ns (max)
- 3.3 V low operating power
 - Active = 135 mA (typical)
 - Standby = 10 μA (typical)
- Fully synchronous interface for easier operation
- Burst counters increment addresses internally
 - Shorten cycle times
 - Minimize bus noise
 - Supported in flow-through and pipelined modes
- Dual chip enables for easy depth expansion
- Upper and lower byte controls for bus matching
- Automatic power-down
- Commercial and industrial temperature ranges
- Available in 100-pin TQFP

Logic Block Diagram

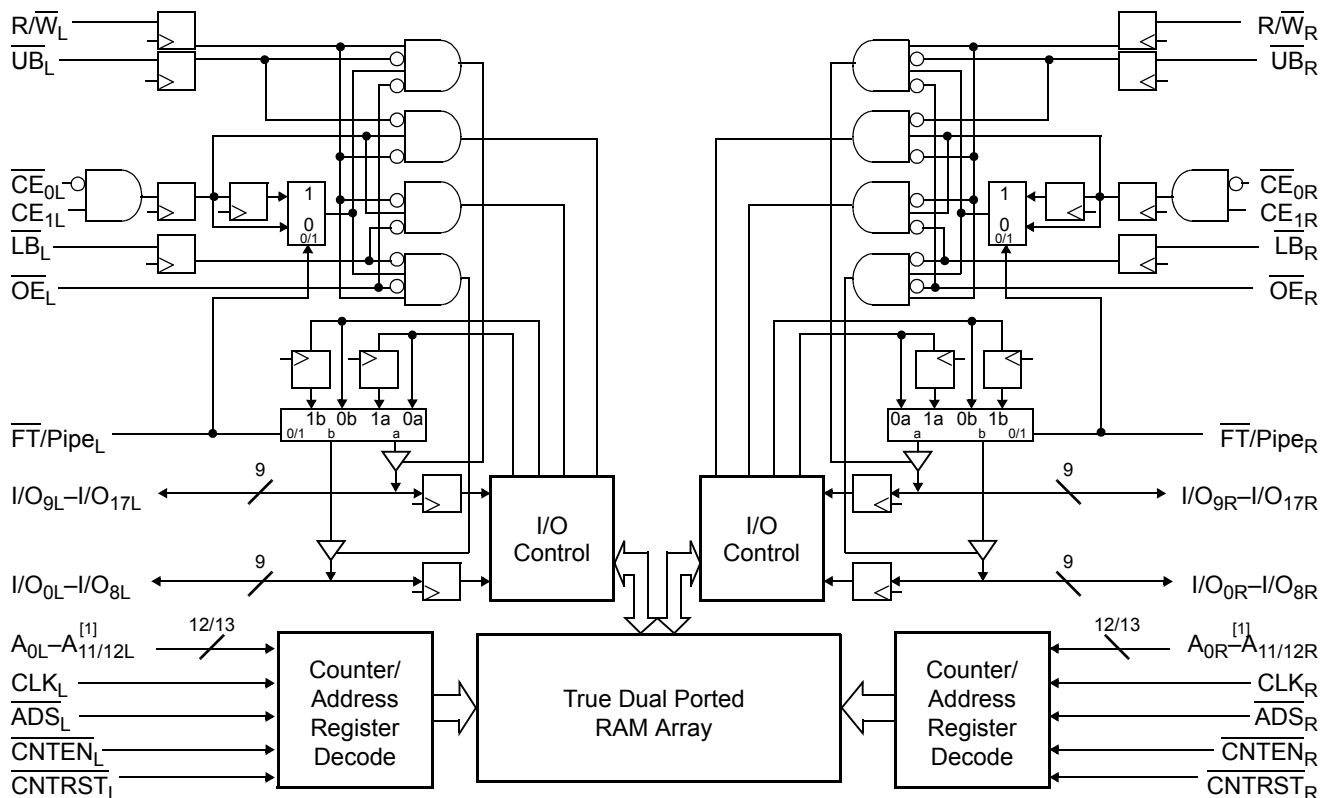

Note
1. A₀-A₁₁ for 4 K; A₀-A₁₂ for 8 K devices.

Functional Description

The CY7C09349AV and CY7C09359AV are high-speed 3.3 V synchronous CMOS 4 K and 8 K × 18 dual-port static RAMs. Two ports are provided, permitting independent, simultaneous access for reads and writes to any location in memory.^[2] Registers on control, address, and data lines allow for minimal set-up and hold times. In pipelined output mode, data is registered for decreased cycle time. Clock to data valid $t_{CD2} = 9$ ns (pipelined). Flow-through mode can also be used to bypass the pipelined output register to eliminate access latency. In flow-through mode data will be available $t_{CD1} = 18$ ns after the address is clocked into the device. Pipelined output or flow-through mode is selected via the $\overline{FT}/Pipe$ pin.

Each port contains a burst counter on the input address register. The internal write pulse width is independent of the LOW-to-HIGH transition of the clock signal. The internal write pulse is self-timed to allow the shortest possible cycle times.

A HIGH on \overline{CE}_0 or LOW on CE_1 for one clock cycle will power down the internal circuitry to reduce the static power consumption. The use of multiple chip enables allows easier banking of multiple chips for depth expansion configurations. In the pipelined mode, one cycle is required with \overline{CE}_0 LOW and CE_1 HIGH to reactivate the outputs.

Counter enable inputs are provided to stall the operation of the address input and utilize the internal address generated by the internal counter for fast interleaved memory applications. A port's burst counter is loaded with the port's address strobe (ADS). When the port's count enable (CNTEN) is asserted, the address counter will increment on each LOW-to-HIGH transition of that port's clock signal. This will read/write one word from/into each successive address location until CNTEN is deasserted. The counter can address the entire memory array and will loop back to the start. Counter reset (CNTRST) is used to reset the burst counter.

All parts are available in 100-pin thin quad plastic flatpack (TQFP) packages.

Note

2. When simultaneously writing to the same location, final value cannot be guaranteed.

Contents

Pin Configuration	4	Switching Waveforms	9
Selection Guide	4	Read/Write and Enable Operation	16
Pin Definitions	5	Address Counter Control Operation	16
Maximum Ratings	5	Ordering Information	17
Operating Range	5	Package Diagram	18
Electrical Characteristics	6	Acronyms	19
Capacitance	6	Document Conventions	19
AC Test Loads	7	Document History Page	20
Switching Characteristics	8	Sales, Solutions, and Legal Information	20

Pin Configuration

Figure 1. 100-pin TQFP (Top View)

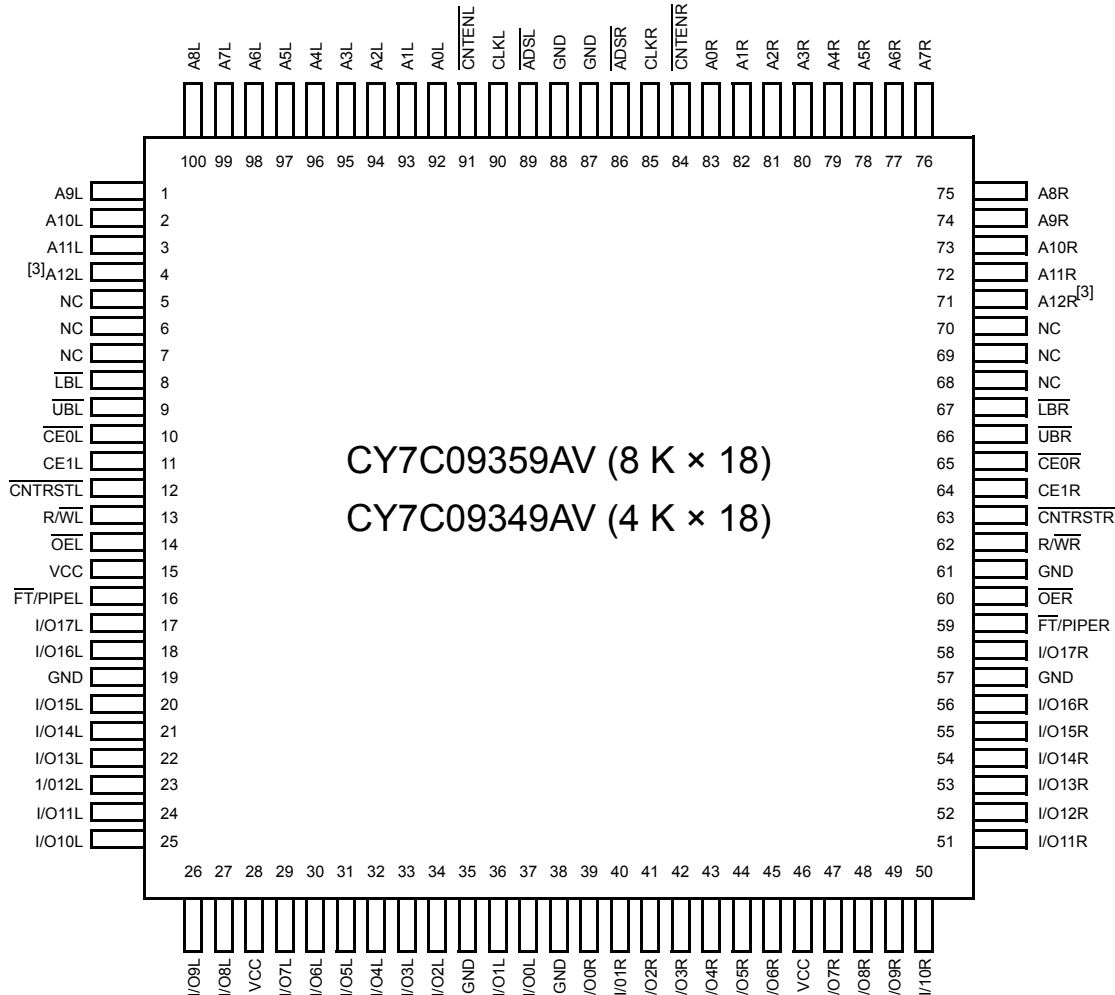

Selection Guide

	CY7C09349AV CY7C09359AV -9	CY7C09349AV CY7C09359AV -12
f _{MAX2} (MHz) (pipelined)	67	50
Max access time (ns) (clock to data, pipelined)	9	12
Typical operating current I _{CC} (mA)	135	115
Typical standby current for I _{SB1} (mA) (both ports TTL level)	20	20
Typical standby current for I _{SB3} (μA) (both ports CMOS level)	10 μA	10 μA

Note

3. This pin is NC for CY7C09349AV.

Pin Definitions

Left Port	Right Port	Description
A _{0L} –A _{12L}	A _{0R} –A _{12R}	Address inputs (A ₀ –A ₁₁ for 4 K, A ₀ –A ₁₂ for 8 K devices).
ADS _L	ADS _R	Address strobe input. Used as an address qualifier. This signal should be asserted LOW during normal read or write transactions. Asserting this signal LOW also loads the burst address counter with data present on the I/O pins.
CE _{0L} , CE _{1L}	CE _{0R} , CE _{1R}	Chip enable input. To select either the left or right port, both CE ₀ and CE ₁ must be asserted to their active states (CE ₀ ≤ V _{IL} and CE ₁ ≥ V _{IH}).
CLK _L	CLK _R	Clock signal. This input can be free running or strobed. Maximum clock input rate is f _{MAX} .
CNTEN _L	CNTEN _R	Counter enable input. Asserting this signal LOW increments the burst address counter of its respective port on each rising edge of CLK. CNTEN is disabled if ADS or CNTRST are asserted LOW.
CNTRST _L	CNTRST _R	Counter reset input. Asserting this signal LOW resets the burst address counter of its respective port to zero. CNTRST is not disabled by asserting ADS or CNTEN.
I/O _{0L} –I/O _{17L}	I/O _{0R} –I/O _{17R}	Data bus input/output (I/O ₀ –I/O ₁₅ for ×16 devices).
LB _L	LB _R	Lower byte select input. Asserting this signal LOW enables read and write operations to the lower byte (I/O ₀ –I/O ₈ for ×18, I/O ₀ –I/O ₇ for ×16) of the memory array. For read operations both the LB and OE signals must be asserted to drive output data on the lower byte of the data pins.
UB _L	UB _R	Upper byte select input. Same function as LB, but to the upper byte (I/O _{8/9L} –I/O _{15/17L}).
OE _L	OE _R	Output enable input. This signal must be asserted LOW to enable the I/O data pins during read operations.
R/W _L	R/W _R	Read/write enable input. This signal is asserted LOW to write to the dual port memory array. For read operations, assert this pin HIGH.
FT/PIPE _L	FT/PIPE _R	Flow-through/pipelined select input. For flow-through mode operation, assert this pin LOW. For pipelined mode operation, assert this pin HIGH.
GND		Ground input.
NC		No connect.
V _{CC}		Power input.

Maximum Ratings

Exceeding maximum ratings may impair the useful life of the device. User guidelines are not tested.

Storage temperature –65 °C to +150 °C

Ambient temperature with power applied . –55 °C to +125 °C

Supply voltage to ground potential –0.5 V to +4.6 V

DC voltage applied to outputs in high Z state –0.5 V to V_{CC} + 0.5 V

DC input voltage –0.5 V to V_{CC} + 0.5 V

Output current into outputs (LOW) 20 mA

Static discharge voltage > 2001 V

Latch-up current > 200 mA

Operating Range

Range	Ambient Temperature	V _{CC}
Commercial	0 °C to +70 °C	3.3 V ± 300 mV
Industrial ^[4]	–40 °C to +85 °C	3.3 V ± 300 mV

Note

4. Industrial parts are available in CY7C09359AV only.

Electrical Characteristics

Over the Operating Range

Parameter	Description	CY7C09349AV CY7C09359AV						Unit	
		-9			-12				
		Min	Typ	Max	Min	Typ	Max		
V _{OH}	Output HIGH voltage (V _{CC} = Min, I _{OH} = -4.0 mA)	2.4	-	-	2.4	-	-	V	
V _{OL}	Output LOW voltage (V _{CC} = Min, I _{OH} = +4.0 mA)	-	-	0.4	-	-	0.4	V	
V _{IH}	Input HIGH voltage	2.0	-	-	2.0	-	-	V	
V _{IL}	Input LOW voltage	-	-	0.8	-	-	0.8	V	
I _{OZ}	Output leakage current	-10	-	10	-10	-	10	μA	
I _{CC}	Operating current (V _{CC} = Max, I _{OUT} = 0 mA) outputs disabled	Commercial	-	135	230	-	115	180	mA
		Industrial ^[5]	-	-	-	-	155	250	mA
I _{SB1}	Standby current (both ports TTL level) ^[6] CE _L and CE _R ≥ V _{IH} , f = f _{MAX}	Commercial	-	20	75	-	20	70	mA
		Industrial ^[5]	-	-	-	-	30	80	mA
I _{SB2}	Standby current (one port TTL level) ^[6] CE _L or CE _R ≥ V _{IH} , f = f _{MAX}	Commercial	-	95	155	-	85	140	mA
		Industrial ^[5]	-	-	-	-	95	150	mA
I _{SB3}	Standby current (both ports CMOS level) ^[6] CE _L and CE _R ≥ V _{CC} - 0.2 V, f = 0	Commercial	-	10	500	-	10	500	μA
		Industrial ^[5]	-	-	-	-	10	500	μA
I _{SB4}	Standby current (one port CMOS level) ^[6] CE _L or CE _R ≥ V _{IH} , f = f _{MAX}	Commercial	-	85	115	-	75	100	mA
		Industrial ^[5]	-	-	-	-	85	110	mA

Capacitance

Parameter	Description	Test Conditions	Max	Unit
C _{IN}	Input capacitance	T _A = 25 °C, f = 1 MHz, V _{CC} = 3.3 V	10	pF
C _{OUT}	Output capacitance		10	pF

Notes

5. Industrial parts are available in CY7C09359AV only.

6. CE_L and CE_R are internal signals. To select either the left or right port, both CE₀ AND CE₁ must be asserted to their active states (CE₀ ≤ V_{IL} and CE₁ ≥ V_{IH}).

AC Test Loads



(a) Normal Load (Load 1)

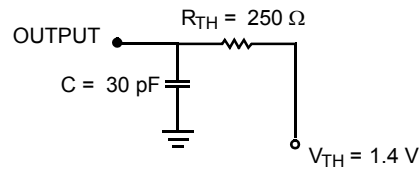

(b) Thévenin Equivalent (Load 1)

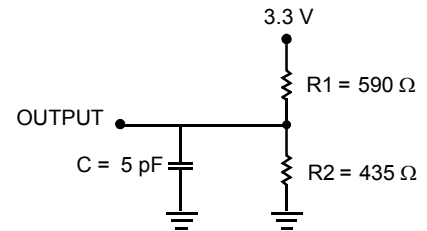

(c) Three-State Delay (Load 2)
(Used for t_{CKLZ} , t_{OLZ} , & t_{OHZ}
including scope and jig)

Switching Characteristics

Over the Operating Range

Parameter	Description	CY7C09349AV CY7C09359AV				Unit
		-9		-12		
		Min	Max	Min	Max	
f_{MAX1}	f_{Max} flow-through	–	40	–	33	MHz
f_{MAX2}	f_{Max} pipelined	–	67	–	50	MHz
t_{CYC1}	Clock cycle time – flow-through	25	–	30	–	ns
t_{CYC2}	Clock cycle time – pipelined	15	–	20	–	ns
t_{CH1}	Clock HIGH time – flow-through	12	–	12	–	ns
t_{CL1}	Clock LOW time – flow-through	12	–	12	–	ns
t_{CH2}	Clock HIGH time – pipelined	6	–	8	–	ns
t_{CL2}	Clock LOW time – pipelined	6	–	8	–	ns
t_R	Clock rise time	–	3	–	3	ns
t_F	Clock fall time	–	3	–	3	ns
t_{SA}	Address set-up time	4	–	4	–	ns
t_{HA}	Address hold time	1	–	1	–	ns
t_{SC}	Chip enable set-up time	4	–	4	–	ns
t_{HC}	Chip enable hold time	1	–	1	–	ns
t_{SW}	$\overline{R/W}$ set-up time	4	–	4	–	ns
t_{HW}	$\overline{R/W}$ hold time	1	–	1	–	ns
t_{SD}	Input data set-up time	4	–	4	–	ns
t_{HD}	Input data hold time	1	–	1	–	ns
t_{SAD}	\overline{ADS} set-up time	4	–	4	–	ns
t_{HAD}	\overline{ADS} hold time	1	–	1	–	ns
t_{SCN}	\overline{CNTEN} set-up time	4	–	4	–	ns
t_{HCN}	\overline{CNTEN} hold time	1	–	1	–	ns
t_{SRST}	\overline{CNTRST} set-up time	4	–	4	–	ns
t_{HRST}	\overline{CNTRST} hold time	1	–	1	–	ns
t_{OE}	Output enable to data valid	–	10	–	12	ns
t_{OLZ}	\overline{OE} to low Z	2	–	2	–	ns
t_{OHZ}	\overline{OE} to high Z	1	7	1	7	ns
t_{CD1}	Clock to data valid – flow-through	–	20	–	25	ns
t_{CD2}	Clock to data valid – pipelined	–	9	–	12	ns
t_{DC}	Data output hold after clock HIGH	2	–	2	–	ns
t_{CKHZ}	Clock HIGH to output high Z	2	9	2	9	ns
t_{CKLZ}	Clock HIGH to output low Z	2	–	2	–	ns
Port to port delays						
t_{CWDD}	Write port clock HIGH to read data delay	–	40	–	40	ns
t_{CCS}	Clock to clock set-up time	–	15	–	15	ns

Switching Waveforms

Read Cycle for Flow-through Output ($\overline{FT}/PIPE = V_{IL}$)^[7, 8, 9, 10]

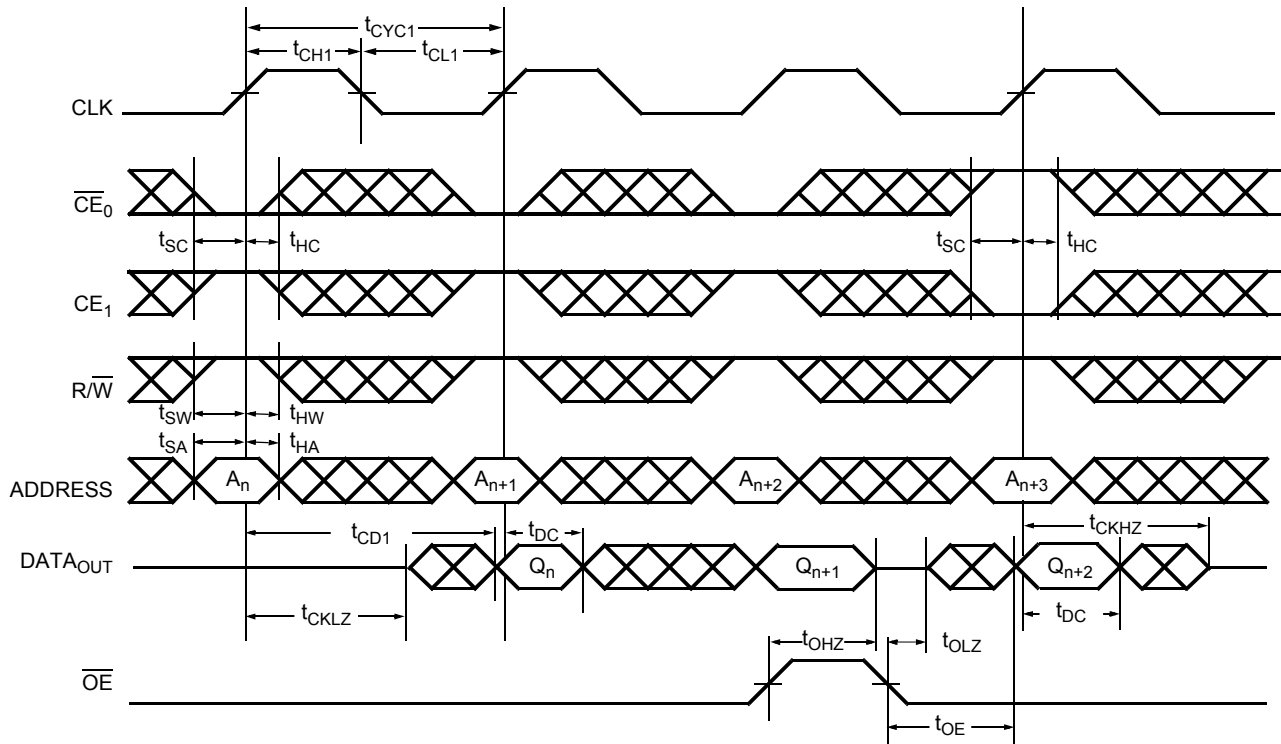

Read Cycle for Pipelined Operation ($\overline{FT}/PIPE = V_{IH}$)^[7, 8, 9, 10]

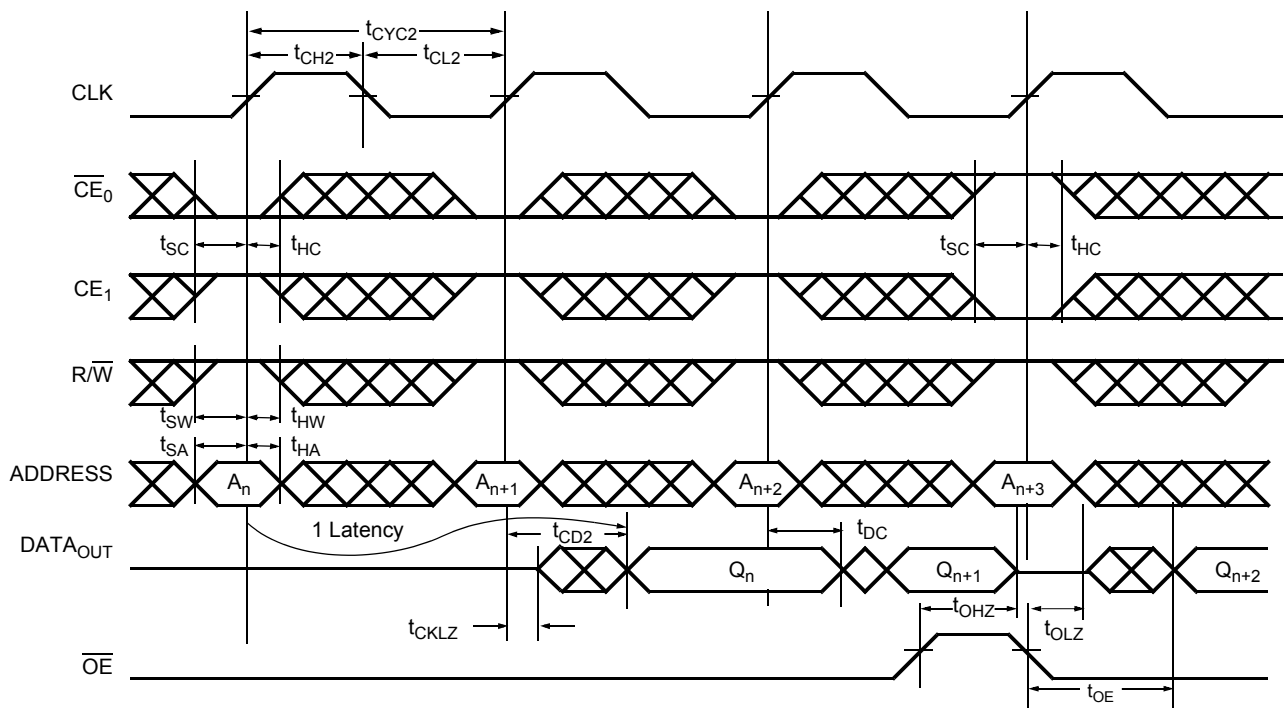

Notes

7. \overline{OE} is asynchronously controlled; all other inputs are synchronous to the rising clock edge.
8. $ADS = V_{IL}$, $CNTEN$ and $CNTRST = V_{IH}$.
9. The output is disabled (high-impedance state) by $\overline{CE}_0 = V_{IH}$ or $CE_1 = V_{IL}$ following the next rising edge of the clock.
10. Addresses do not have to be accessed sequentially since $ADS = V_{IL}$ constantly loads the address on the rising edge of the CLK. Numbers are for reference only.

Switching Waveforms (continued)
Bank Select Pipelined Read^[11, 12]

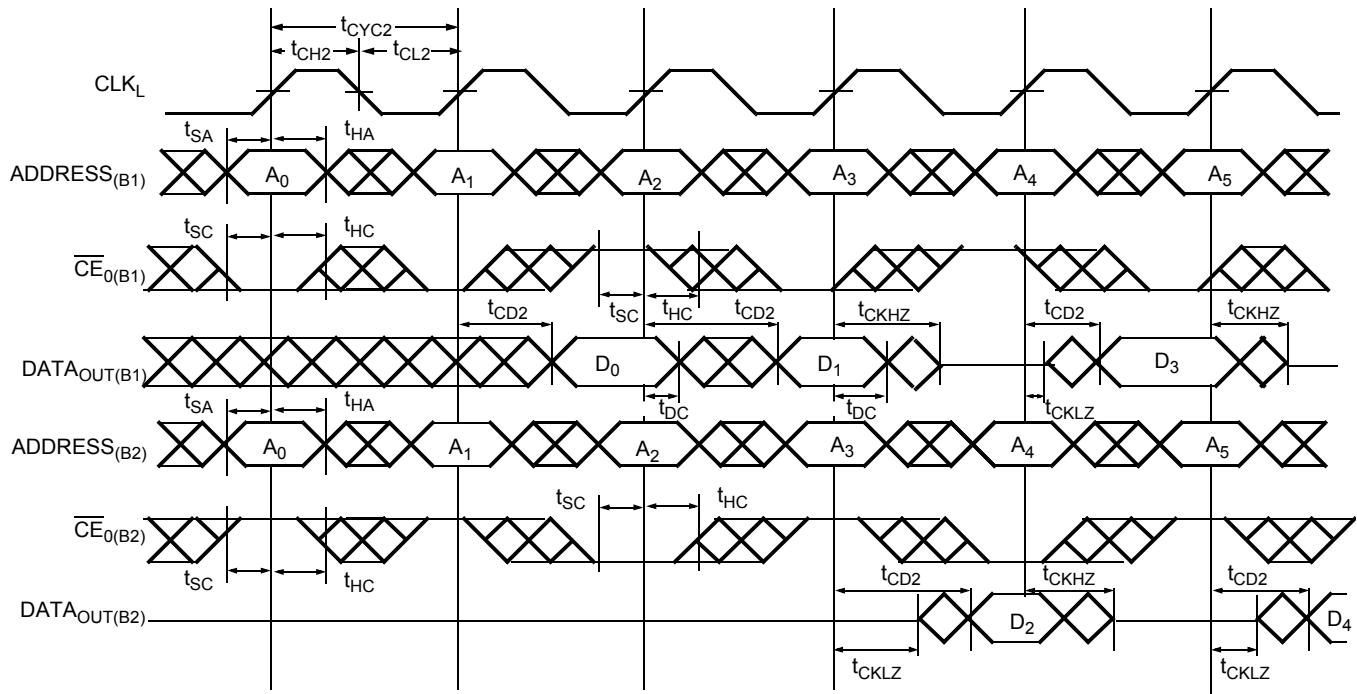

Left Port Write to Flow-through Right Port Read^[13, 14, 15, 16]

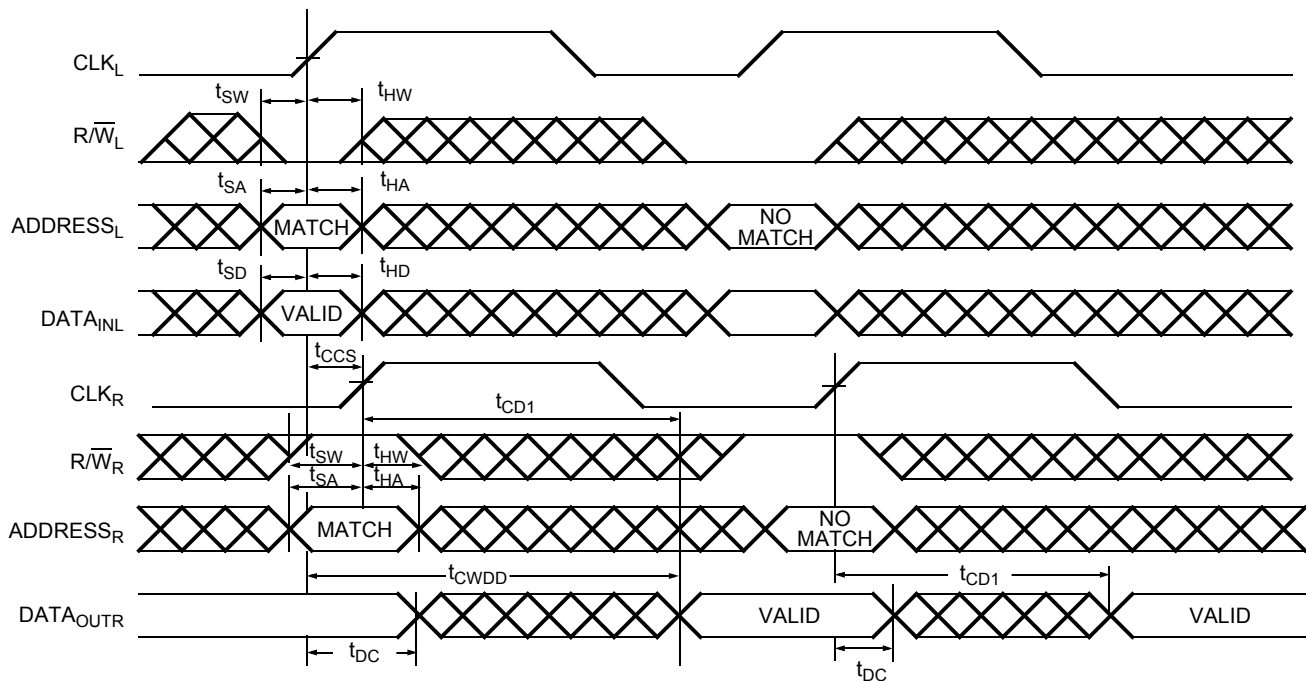

Notes

11. In this depth expansion example, B1 represents Bank #1 and B2 is Bank #2; Each bank consists of one Cypress dual-port device from this data sheet.
ADDRESS_(B1) = ADDRESS_(B2).
12. UB, LB, OE and ADS = V_{IL}; CE_{1(B1)}, CE_{1(B2)}, R/W, CNTEN, and CNTRST = V_{IH}.
13. The same waveforms apply for a right port write to flow-through left port read.
14. CE₀, UB, LB, and ADS = V_{IL}; CE₁, CNTEN, and CNTRST = V_{IH}.
15. OE = V_{IL} for the right port, which is being read from. OE = V_{IH} for the left port, which is being written to.
16. If t_{CCS} ≤ maximum specified, then data from right port READ is not valid until the maximum specified for t_{CWDD}. If t_{CCS} > maximum specified, then data is not valid until t_{CCS} + t_{CD1}. t_{CWDD} does not apply in this case.

Switching Waveforms (continued)

Pipelined Read-to-Write-to-Read ($\overline{OE} = V_{IL}$)^[17, 18, 19, 20]

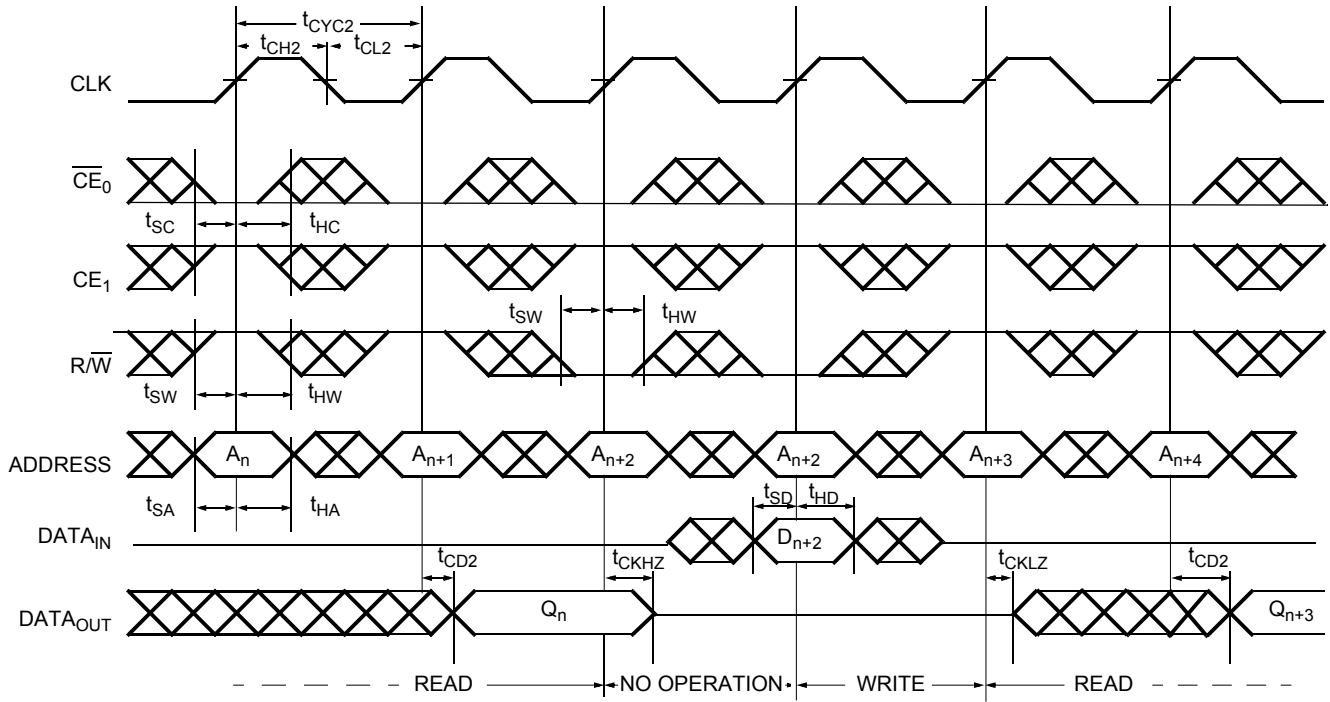

Pipelined Read-to-Write-to-Read (\overline{OE} Controlled)^[17, 18, 19, 20]

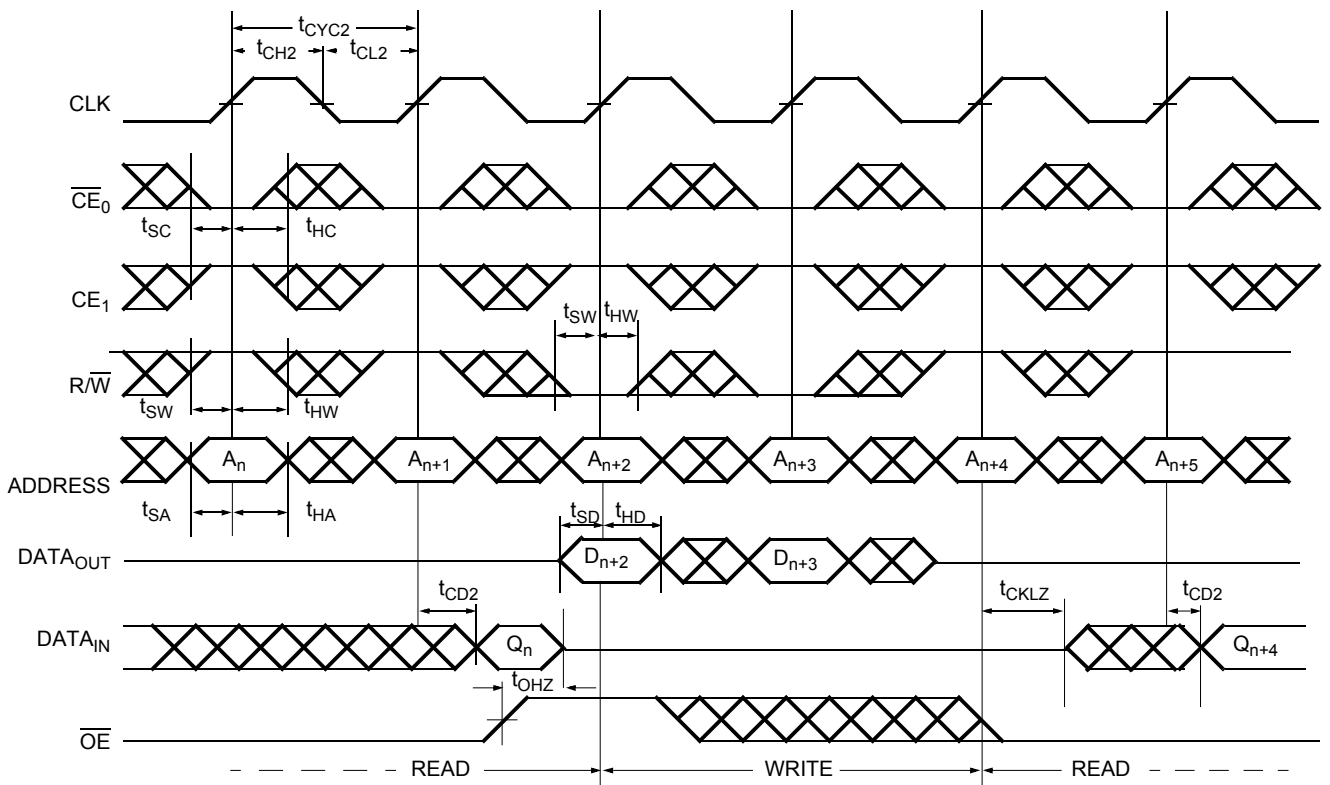

Notes

- 17. Addresses do not have to be accessed sequentially since $\overline{ADS} = V_{IL}$ constantly loads the address on the rising edge of the CLK. Numbers are for reference only.
- 18. Output state (HIGH, LOW, or high-impedance) is determined by the previous cycle control signals.
- 19. \overline{CE}_0 and $\overline{ADS} = V_{IL}$; \overline{CE}_1 , \overline{CNTEN} , and $\overline{CNTRST} = V_{IH}$.
- 20. During "No operation", data in memory at the selected address may be corrupted and should be rewritten to ensure data integrity.

Switching Waveforms (continued)

Flow-through Read-to-Write-to-Read ($\overline{OE} = V_{IL}$)^[21, 22, 24, 25]

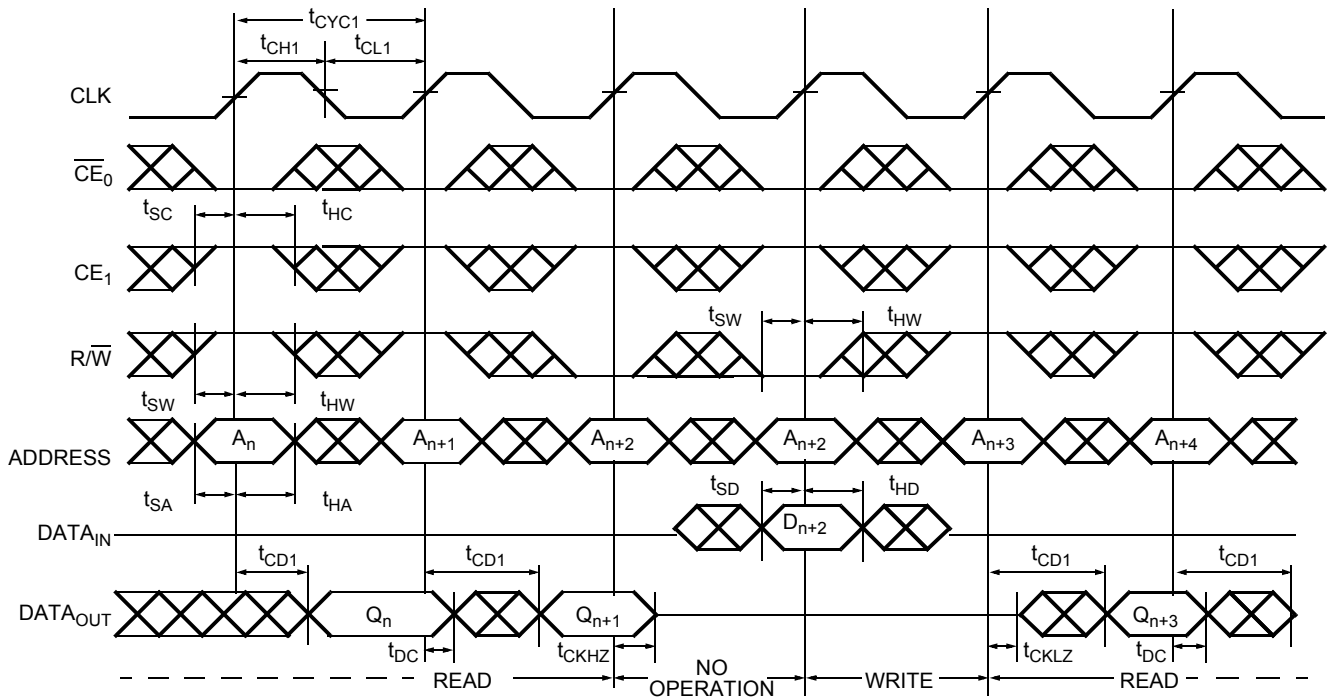

Flow-through Read-to-Write-to-Read (\overline{OE} Controlled)^[21, 22, 23, 24, 25]

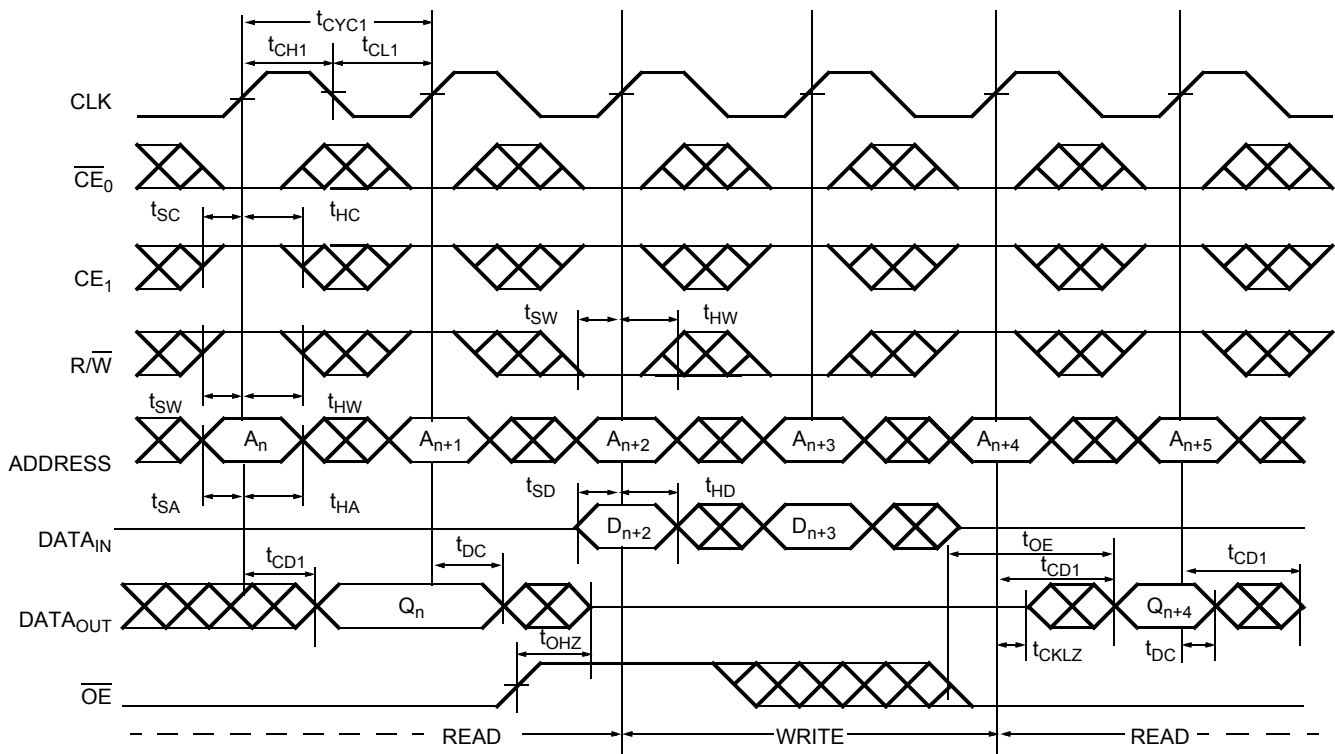

Notes

- 21. $\overline{ADS} = V_{IL}$, \overline{CNTEN} and $\overline{CNTRST} = V_{IH}$.
- 22. Addresses do not have to be accessed sequentially since $\overline{ADS} = V_{IL}$ constantly loads the address on the rising edge of the CLK. Numbers are for reference only.
- 23. Output state (HIGH, LOW, or high-impedance) is determined by the previous cycle control signals.
- 24. \overline{CE}_0 and $\overline{ADS} = V_{IL}$; \overline{CE}_1 , \overline{CNTEN} , and $\overline{CNTRST} = V_{IH}$.
- 25. During "No operation," data in memory at the selected address may be corrupted and should be rewritten to ensure data integrity.

Switching Waveforms (continued)

Pipelined Read with Address Counter Advance^[26]

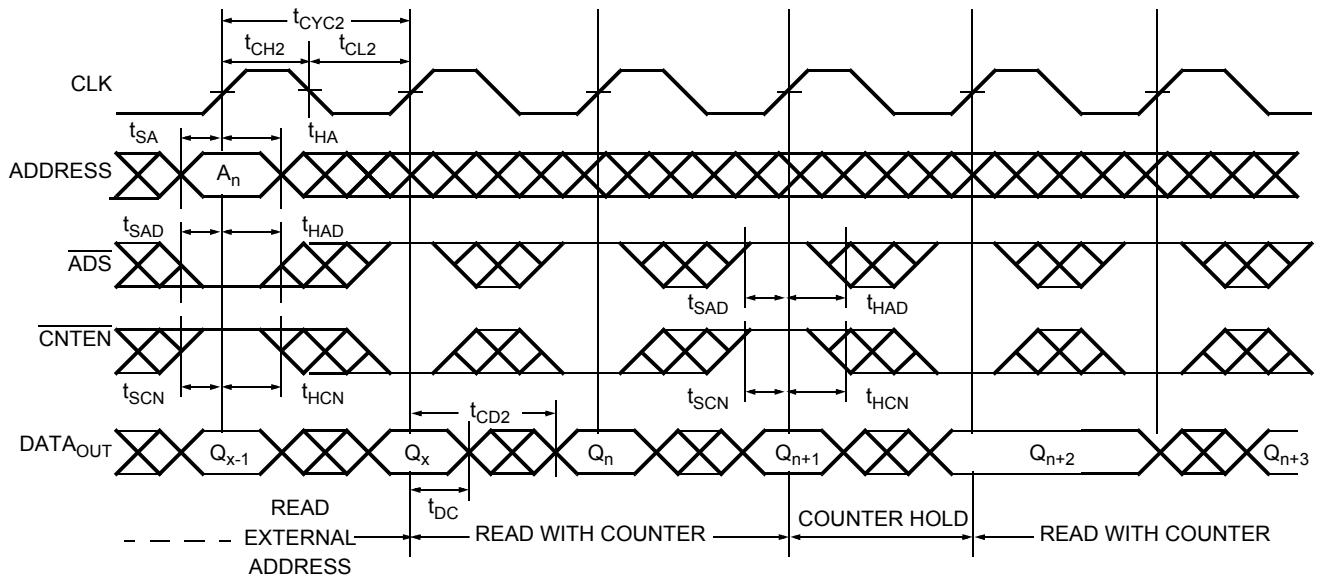

Flow-through Read with Address Counter Advance^[26]

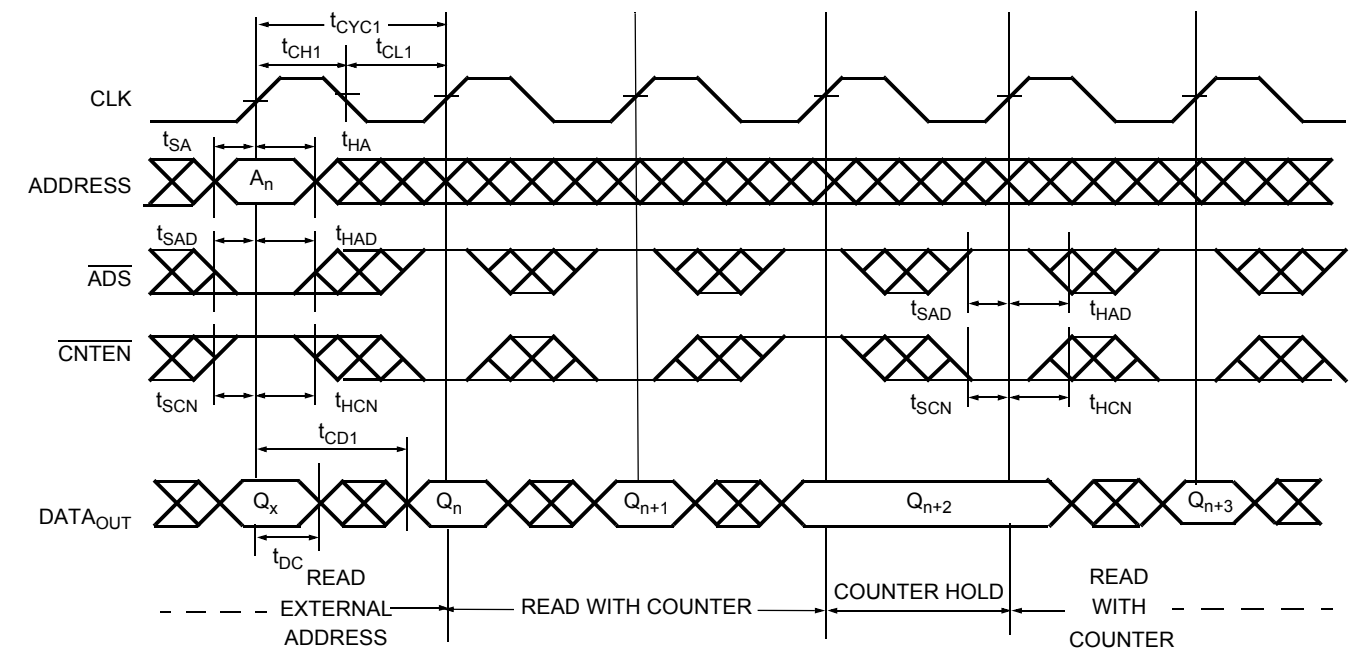

Note
26. \overline{CE}_0 and $\overline{OE} = V_{IL}$; CE_1 , R/\overline{W} and $\overline{CNTRST} = V_{IH}$.

Switching Waveforms (continued)

Write with Address Counter Advance (Flow-through or Pipelined Outputs)^[27, 28]

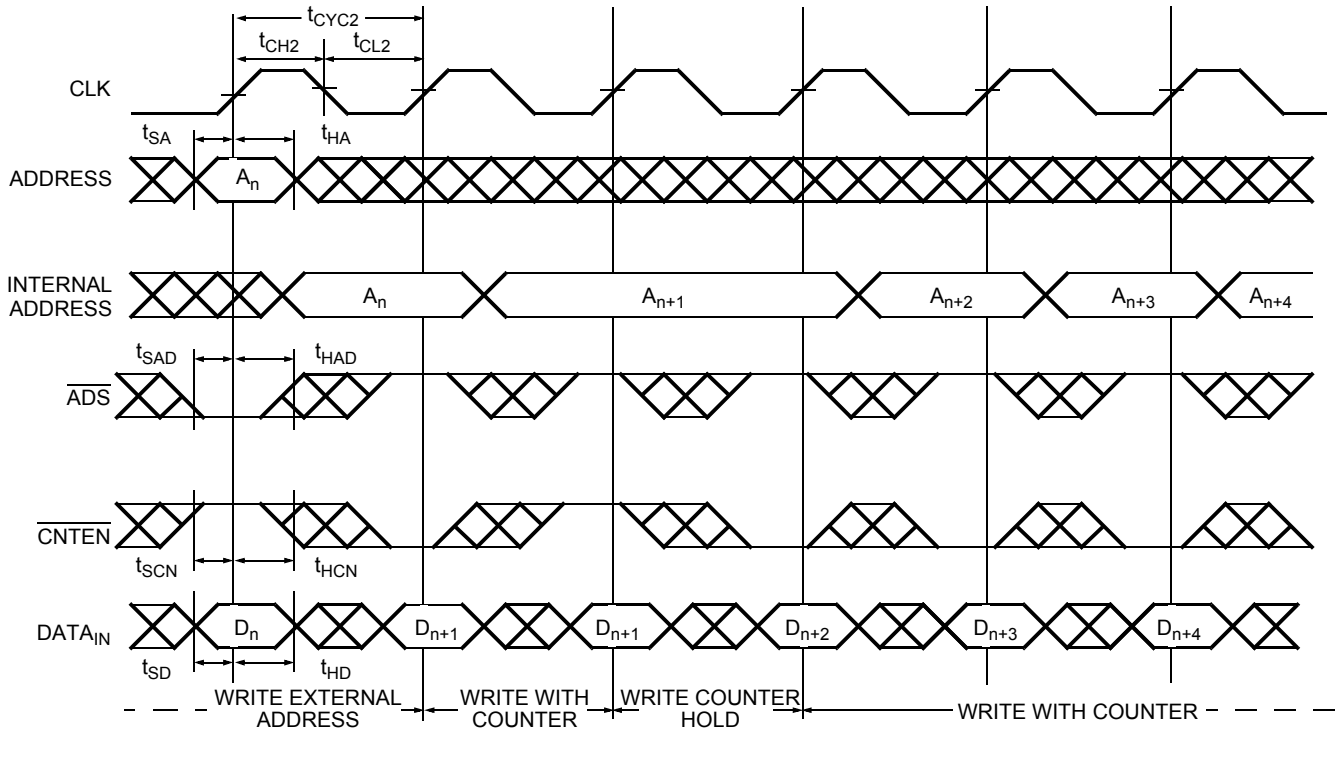

Notes

27. $\overline{CE_0}$, \overline{UB} , \overline{LB} , and $R/\overline{W} = V_{IL}$; CE_1 and $\overline{CNTST} = V_{IH}$.

28. The "Internal Address" is equal to the "External Address" when $\overline{ADS} = V_{IL}$ and equals the counter output when $\overline{ADS} = V_{IH}$.

Switching Waveforms (continued)



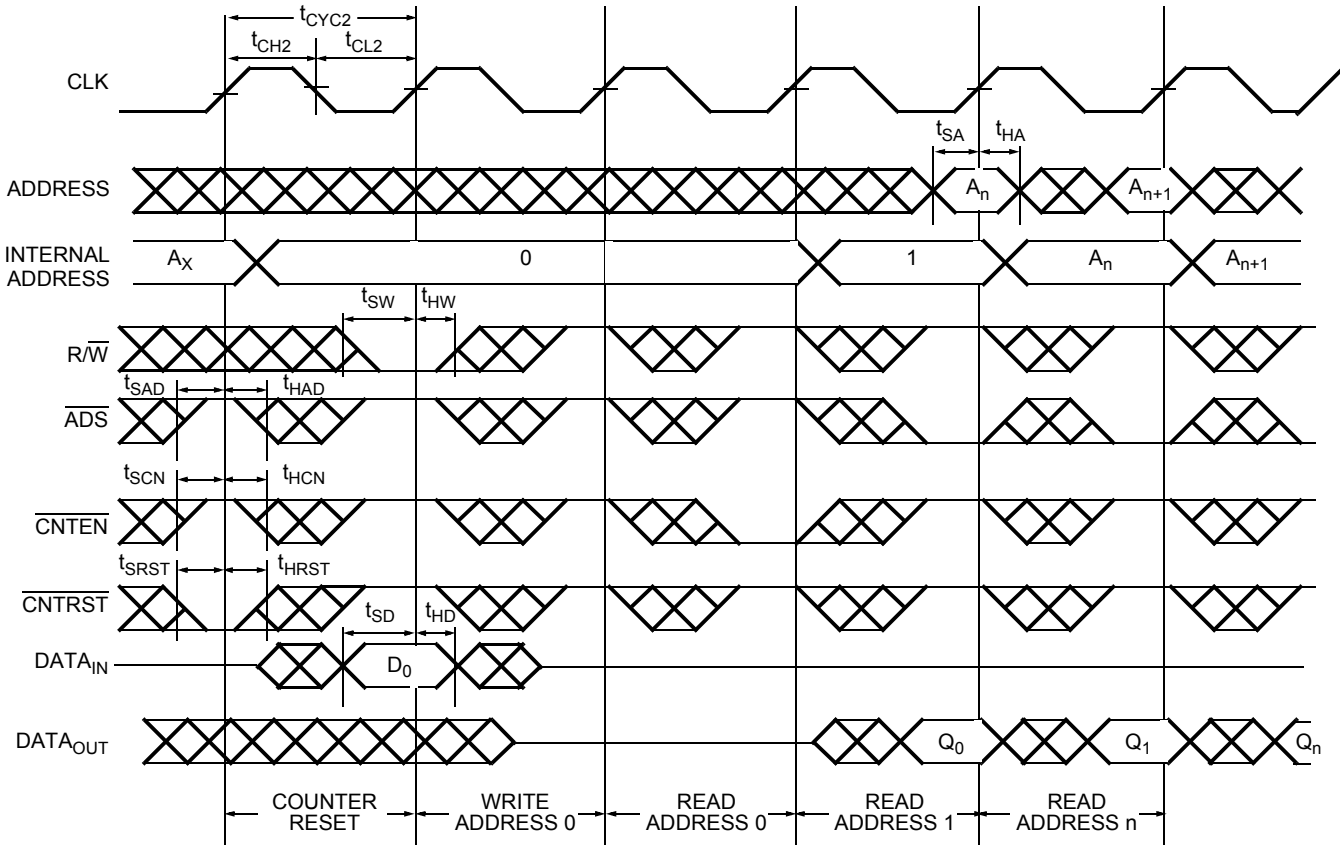

Counter Reset (Pipelined Outputs) [29, 30, 31, 32]







Notes

- 29. Addresses do not have to be accessed sequentially since $\overline{ADS} = V_{IL}$ constantly loads the address on the rising edge of the CLK. Numbers are for reference only.
- 30. Output state (HIGH, LOW, or high-impedance) is determined by the previous cycle control signals.
- 31. \overline{CE}_0 , \overline{UB} , and $\overline{LB} = V_{IL}$; $CE_1 = V_{IH}$.
- 32. No dead cycle exists during counter reset. A READ or WRITE cycle may be coincidental with the counter reset.

Read/Write and Enable Operation^[33, 34, 35]

Inputs					Outputs	Operation
OE	CLK	CE ₀	CE ₁	R/W	I/O ₀ –I/O ₁₇	
X		H	X	X	High Z	Deselected ^[36]
X		X	L	X	High Z	Deselected ^[36]
X		L	H	L	D _{IN}	Write
L		L	H	H	D _{OUT}	Read ^[36]
H	X	L	H	X	High Z	Outputs disabled

Address Counter Control Operation^[33, 37, 38, 39]

Address	Previous Address	CLK	ADS	CNTEN	CNTRST	I/O	Mode	Operation
X	X		X	X	L	D _{out(0)}	Reset	Counter reset to address 0
A _n	X		L	X	H	D _{out(n)}	Load	Address load into counter
X	A _n		H	H	H	D _{out(n)}	Hold	External address blocked—counter disabled
X	A _n		H	L	H	D _{out(n+1)}	Increment	Counter enabled—internal address generation

Notes

33. "X" = "Don't Care," "H" = V_{IH}, "L" = V_{IL}.
 34. ADS, CNTEN, CNTRST = "Don't Care."
 35. OE is an asynchronous input signal.
 36. When CE changes state in the pipelined mode, deselection and read happen in the following clock cycle.
 37. CE₀ and OE = V_{IL}; CE₁ and R/W = V_{IH}.
 38. Data shown for flow-through mode; pipelined mode output will be delayed by one cycle.
 39. Counter operation is independent of CE₀ and CE₁.

Ordering Information

4 K × 18 3.3 V Synchronous Dual-Port SRAM

Speed (ns)	Ordering Code	Package Name	Package Type	Operating Range
9	CY7C09349AV-9AXC	A100	100-pin Pb-free Thin Quad Flat Pack	Commercial
12	CY7C09349AV-12AXC	A100	100-pin Pb-free Thin Quad Flat Pack	Commercial

8 K × 18 3.3 V Synchronous Dual-Port SRAM

Speed (ns)	Ordering Code	Package Name	Package Type	Operating Range
9	CY7C09359AV-9AXC	A100	100-pin Pb-free Thin Quad Flat Pack	Commercial

Ordering Code Definitions

CY7C 09 XX9 AV - XX AX C

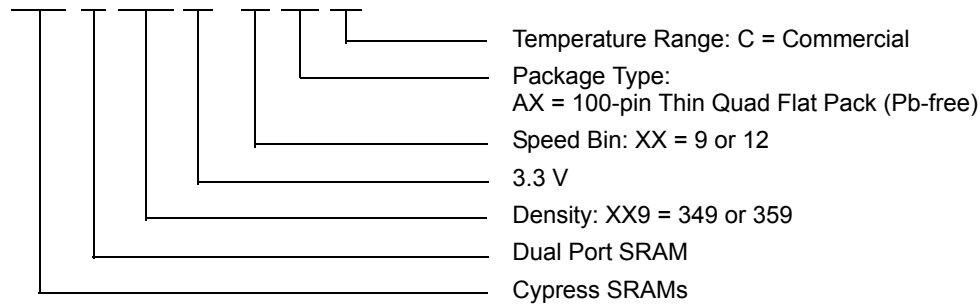

Package Diagram

Figure 2. 100-pin Thin Plastic Quad Flat Pack (TQFP) A100

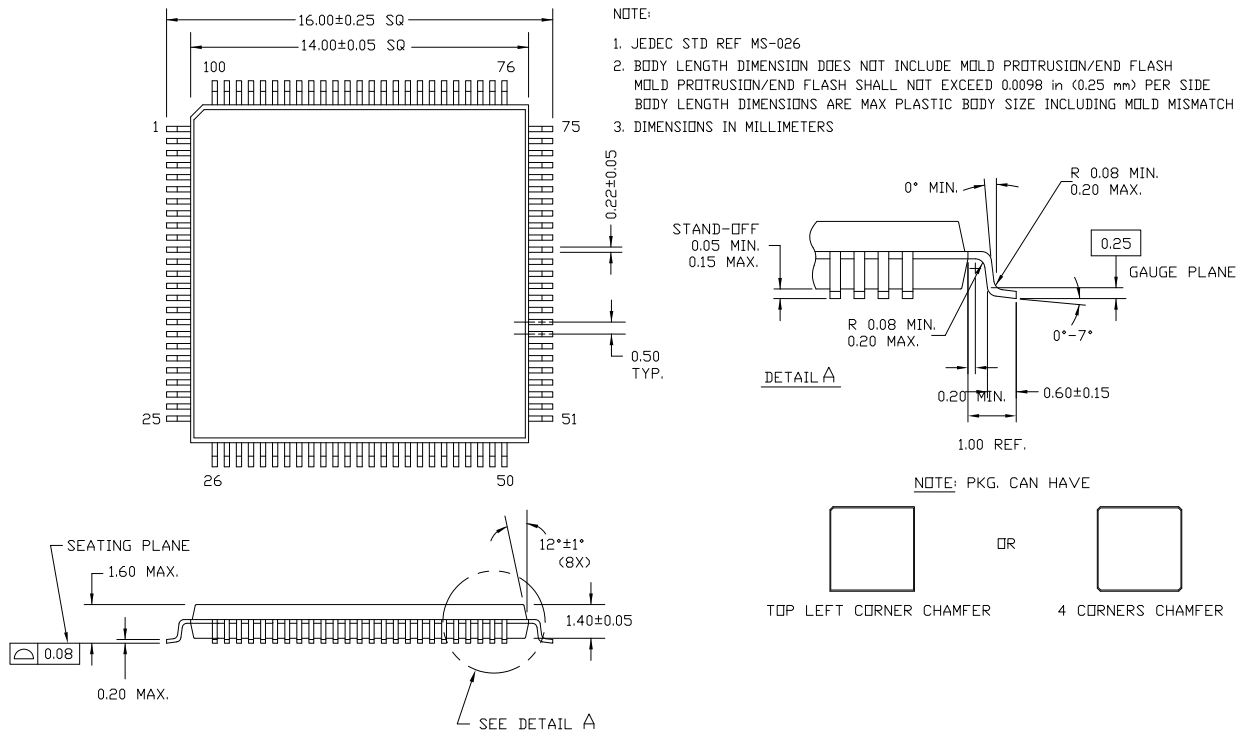

51-85048 *D

Acronyms

Acronym	Description
CE	chip enable
CLK	clock
CMOS	complementary metal oxide semiconductor
I/O	Input/output
OE	output enable
SRAM	static random access memory
TQFP	thin quad flat pack

Document Conventions

Units of Measure

Symbol	Unit of Measure
ns	nano seconds
V	Volts
μ A	micro Amperes
mA	milli Amperes
mV	milli Volts
mW	milli Watts
MHz	Mega Hertz
pF	pico Farad
$^{\circ}$ C	degree Celcius
W	Watts

Document History Page

Document Title: CY7C09349AV/CY7C09359AV 3.3 V 4 K/8 K × 18 Synchronous Dual-Port Static RAM				
Document Number: 001-63888				
REV.	ECN NO.	Issue Date	Orig. of Change	Description of Change
**	2998931	09/16/2010	RAME	New Datasheet

Sales, Solutions, and Legal Information

Worldwide Sales and Design Support

Cypress maintains a worldwide network of offices, solution centers, manufacturer’s representatives, and distributors. To find the office closest to you, visit us at [Cypress Locations](#).

Products

Automotive	cypress.com/go/automotive
Clocks & Buffers	cypress.com/go/clocks
Interface	cypress.com/go/interface
Lighting & Power Control	cypress.com/go/powerpsoc cypress.com/go/plc
Memory	cypress.com/go/memory
Optical & Image Sensing	cypress.com/go/image
PSoC	cypress.com/go/psoc
Touch Sensing	cypress.com/go/touch
USB Controllers	cypress.com/go/USB
Wireless/RF	cypress.com/go/wireless

PSoC Solutions

psoc.cypress.com/solutions
 PSoC 1 | PSoC 3 | PSoC 5

© Cypress Semiconductor Corporation, 2010. The information contained herein is subject to change without notice. Cypress Semiconductor Corporation assumes no responsibility for the use of any circuitry other than circuitry embodied in a Cypress product. Nor does it convey or imply any license under patent or other rights. Cypress products are not warranted nor intended to be used for medical, life support, life saving, critical control or safety applications, unless pursuant to an express written agreement with Cypress. Furthermore, Cypress does not authorize its products for use as critical components in life-support systems where a malfunction or failure may reasonably be expected to result in significant injury to the user. The inclusion of Cypress products in life-support systems application implies that the manufacturer assumes all risk of such use and in doing so indemnifies Cypress against all charges.

Any Source Code (software and/or firmware) is owned by Cypress Semiconductor Corporation (Cypress) and is protected by and subject to worldwide patent protection (United States and foreign), United States copyright laws and international treaty provisions. Cypress hereby grants to licensee a personal, non-exclusive, non-transferable license to copy, use, modify, create derivative works of, and compile the Cypress Source Code and derivative works for the sole purpose of creating custom software and or firmware in support of licensee product to be used only in conjunction with a Cypress integrated circuit as specified in the applicable agreement. Any reproduction, modification, translation, compilation, or representation of this Source Code except as specified above is prohibited without the express written permission of Cypress.

Disclaimer: CYPRESS MAKES NO WARRANTY OF ANY KIND, EXPRESS OR IMPLIED, WITH REGARD TO THIS MATERIAL, INCLUDING, BUT NOT LIMITED TO, THE IMPLIED WARRANTIES OF MERCHANTABILITY AND FITNESS FOR A PARTICULAR PURPOSE. Cypress reserves the right to make changes without further notice to the materials described herein. Cypress does not assume any liability arising out of the application or use of any product or circuit described herein. Cypress does not authorize its products for use as critical components in life-support systems where a malfunction or failure may reasonably be expected to result in significant injury to the user. The inclusion of Cypress’ product in a life-support systems application implies that the manufacturer assumes all risk of such use and in doing so indemnifies Cypress against all charges.

Use may be limited by and subject to the applicable Cypress software license agreement.

Looking for pricing, stock, or lifecycle information?

Click below to explore more details on WIN SOURCE:

 [View CY7C09359AV-9AXC on WIN SOURCE](#)

 [Infineon Technologies](#) Information

Optimize Your Supply Chain with WIN SOURCE Solutions

-  Global Sourcing Solution
-  Obsolete Management
-  Cost Control Management
-  Shortage Management
-  Alternative Solution
-  Excess Inventory Management