

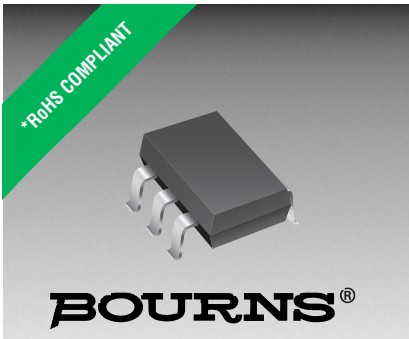

**THE DATASHEET OF
CDSOT236-DSL0312**





Features

- RoHS compliant*
- Low capacitance <5 pF
- ESD protection
- Surge protection

Applications

- ADSL / VDSL cards
- Personal Digital Assistants (PDAs)
- Mobile phones and accessories
- Portable electronics

CDSOT236-DSL03xx - TVS Diode Array Series

General Information

The CDSOT236-DSL03xx device provides ESD, EFT and surge protection for high-speed data ports to assist in meeting IEC 61000-4-2 (ESD), IEC 61000-4-4 (EFT) and IEC 61000-4-5 (Surge) requirements. The Transient Voltage Suppressor array is available with a Working Peak Reverse Voltage of 12 V or 24 V.

The SOT23-6L packaged device will mount directly onto the industry standard SOT23-6L footprint and is easy to handle with standard pick and place equipment.

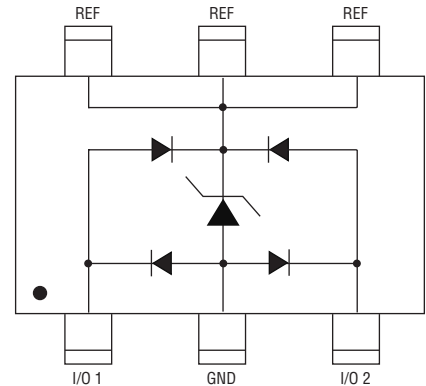

Absolute Maximum Ratings, $T_A = 25^\circ\text{C}$ (Unless Otherwise Noted)

Rating	Symbol	CDSOT236-		Unit
		DSL0312	DSL0324	
Working Peak Voltage	V_{WM}	12	24	V
Peak Pulse Current ($t_p = 8/20 \mu\text{s}$)	I_{PPM}	35	15	A
Peak Pulse Power ($t_p = 8/20 \mu\text{s}$)	PPP	500		W
ESD (IEC61000-4-2 Contact)		8		kV
ESD (IEC61000-4-2 Air)		15		kV
Operating Temperature	T_L	-40 to +125		$^\circ\text{C}$
Storage Temperature	T_{STG}	-55 to +150		$^\circ\text{C}$

Electrical Characteristics, $T_A = 25^\circ\text{C}$ (Unless Otherwise Noted)

Parameter	Test Condition (Note 1)	Min.	Typ.	Max.	Unit
V_{BR} Breakdown Voltage	$I_{BR} = 1 \text{ mA}$	'DSL0312 14 'DSL0324 26			V
V_C Clamping Voltage	$I_P = 1 \text{ A}, 8/20 \mu\text{s}$	'DSL0312 'DSL0324	18 31	20 38	V
V_C Clamping Voltage	$I_P = 10 \text{ A}, t_w = 1 \mu\text{s}$	'DSL0312 'DSL0324	21 37		V
V_C Clamping Voltage	$I_P = 35 \text{ A}, 8/20 \mu\text{s}$ $I_P = 15 \text{ A}, 8/20 \mu\text{s}$	'DSL0312 'DSL0324	34 40		V
I_D Leakage Current	$V_D = V_{WM}$			100	nA
C Capacitance	$V_D = 1 \text{ V}, f = 10 \text{ MHz}, 1 \text{ V}_{rms}$		1.4	5	pF
ΔC Capacitance Variation	$V_D = 1 \text{ V to } V_{WM}, f = 10 \text{ MHz}, 1 \text{ V}_{rms}$		0.2	2	pF

Note 1: All measurements made between I/O 1 and I/O 2.

*RoHS Directive 2002/95/EC Jan. 27, 2003 including annex and RoHS Recast 2011/65/EU June 8, 2011. Specifications are subject to change without notice.

The device characteristics and parameters in this data sheet can and do vary in different applications and actual device performance may vary over time. Users should verify actual device performance in their specific applications.

CDSOT236-DSL03xx - TVS Diode Array Series



Performance Graphs

Maximum Current vs. Pulse Duration

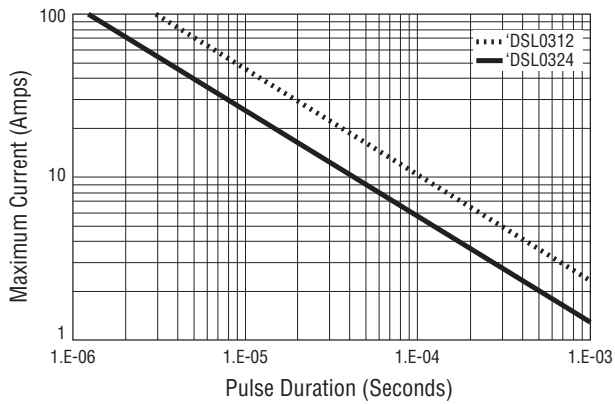

Normalized Capacitance vs. V_D

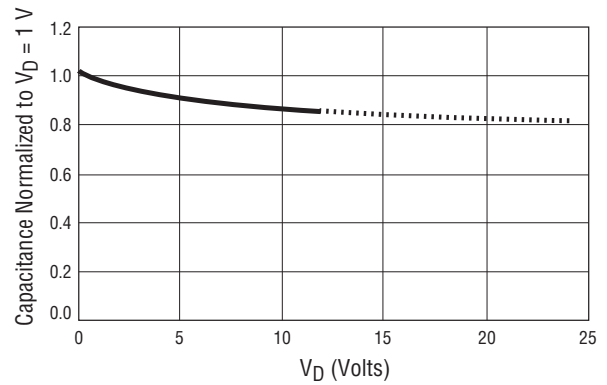

Clamping Waveform for 'DSL0312 During a 20 A, 8/20 μs Surge

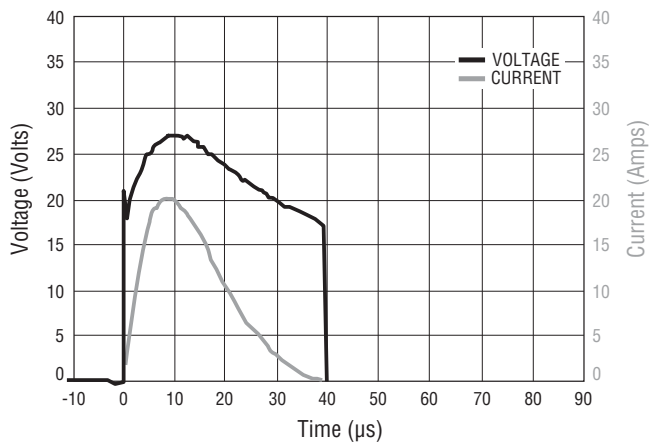

Clamping Waveform for 'DSL0324 During a 10 A, 8/20 μs Surge

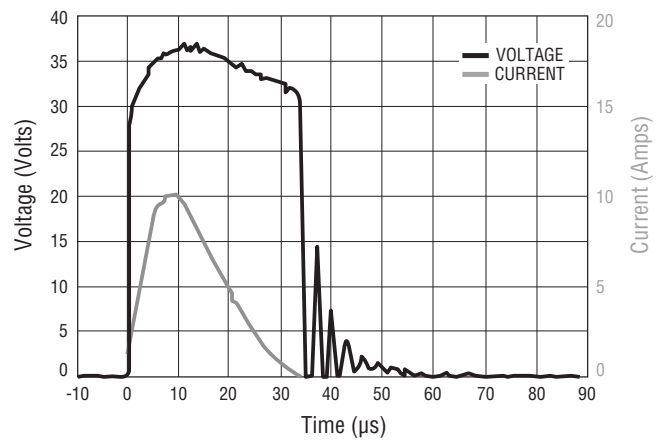

Application Information

Communication systems with exposed signal lines are often subjected to high level transient threats. The CDSOT236-DSL03xx family of devices was designed to help protect signal lines from threats such as those defined in Telcordia GR-1089 and ITU-T.

Figure 1 shows the CDSOT236-DSL03xx TVS diode array used in a design topology that protects a VDSL driver. The diode array limits the peak differential voltage across the VDSL driver outputs. The current limiting resistors (R_P), typically about 1 ohm, limit the peak current seen by the driver. Low voltage varistors MOV1 and MOV2, with a typical working voltage of less than 20 V, limit the current in the line side of the transformer by limiting

the voltage across it. Exact values for the current limiting resistors and the varistors are dependent on the characteristics of the transformer as well as the sensitivity of the driver to overvoltage/overcurrent conditions. The use of primary protectors downstream from the device will also influence the requirements for this protection circuit design. In applications sensitive to very low levels of leakage current, optional bias resistors R_{B1} and R_{B2} can be used. Both resistors would be required for dual supply applications. Only R_{B1} is required for single supply applications. In this case, the anodes of the diode array should be connected to ground.

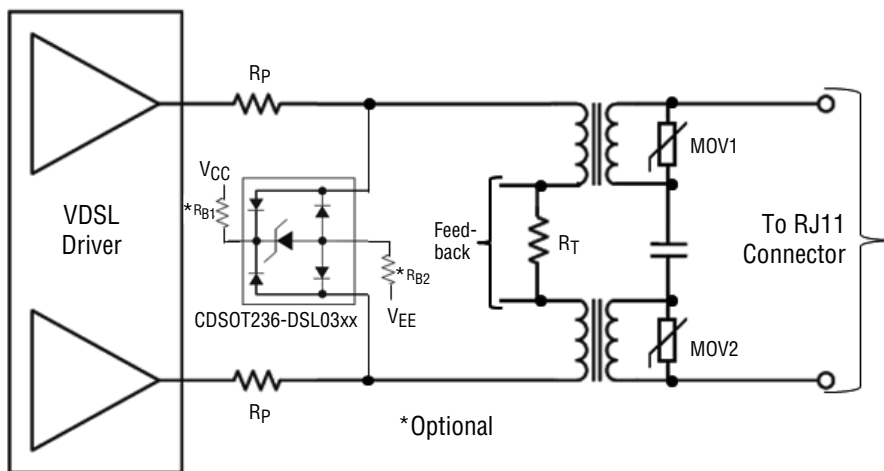

Figure 1. VDSL Driver Protection Design Topology

When routing differential signal traces on the PCB, such as in a VDSL application, it is important to maintain symmetry in the routing. Figure 2 below shows an example of how differential traces that connect to the CDSOT236-DSL03xx TVS diode array can be routed. As the signal traces approach the diode array

the traces should be flared out to make the connections with the device and then brought back together on the opposite side of the device. Routing to the next destination would continue from there.

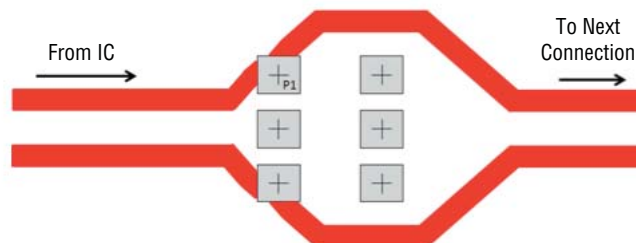

Figure 2. Connecting a Differential Signal to the Model CDSOT236-DSL03xx

CDSOT236-DSL03xx - TVS Diode Array Series

BOURNS®

Application Information (Continued)

In applications where the current limiting resistors (R_P in Figure 1) cannot reduce the current into (or out of) the driver to an acceptable level, the resistors can be replaced with a Bourns® Transient Current Suppressor (TCS™) device as shown in Figure 3. The Model TCS-DL004-750-WH shown in Figure 3 is a dual channel device that has a nominal series resistance of only 1 ohm. The resistance between the two channels is very well matched with a nominal maximum difference of + 0.02 ohms

between the channels. This device has a nominal trigger current of 1.1 amps. The current through the device would be limited to this level with up to 40 V across this device, making it dramatically more effective than a 1 ohm series resistor. Devices with different trigger levels and series resistances are also available. For additional information on the TCS™ family of devices, please consult the data sheets on our website at http://www.bourns.com/ProductLine.aspx?name=transient_current_suppressors.

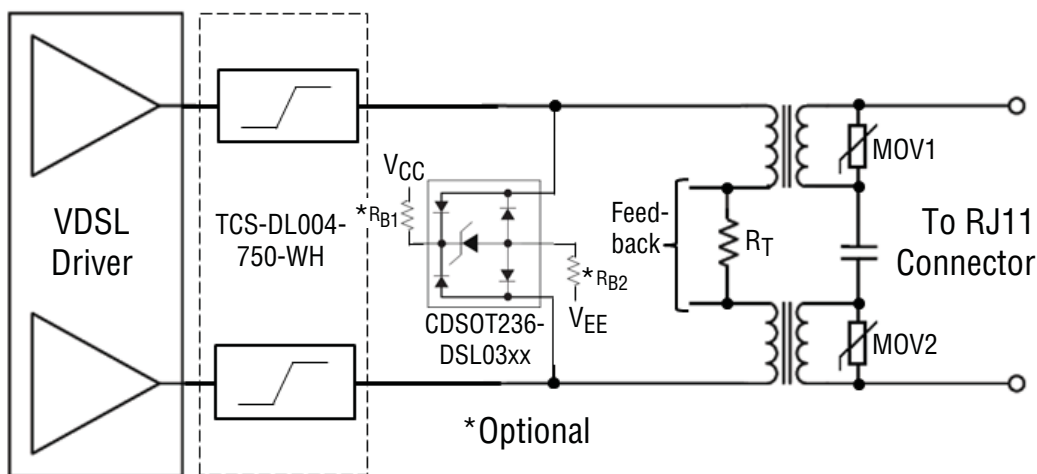

Figure 3. VDSL Driver Protection Design with Transient Current Suppressor Technology

Figure 4 shows how the trace routing should be done when the TCS™ device is used in conjunction with the CDSOT236-DSL03xx TVS diode array.

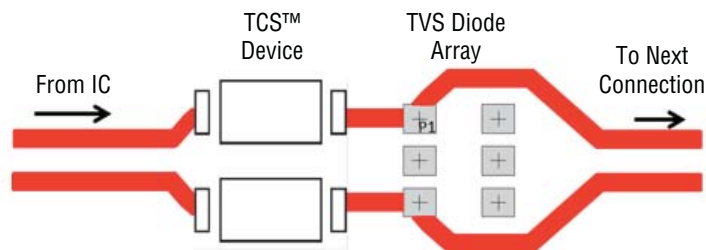

Figure 4. Connecting a Differential Signal to the Model CDSOT236-DSL03xx and TCS™ Device

CDSOT236-DSL03xx - TVS Diode Array Series



Product Dimensions

This is a molded SOT23-6L package with RoHS compliant 100 % Matte Sn on the lead frame. It weighs approximately 15 mg and has a flammability rating of UL 94V-0.

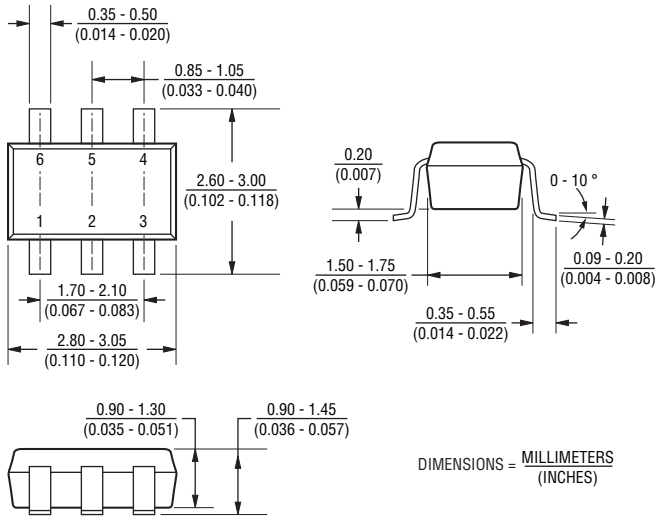

Recommended Footprint

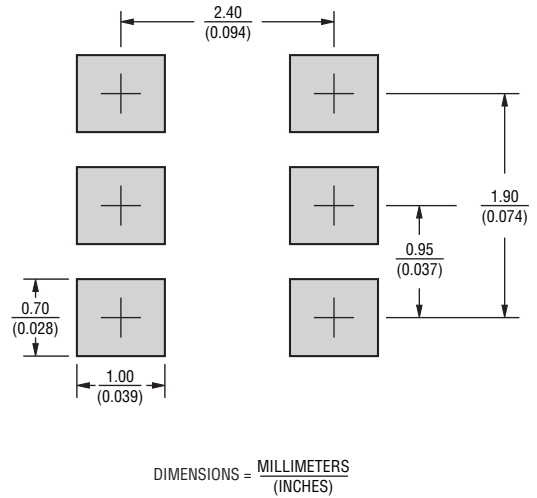

Typical Part Marking

CDSOT236-DSL0312.....	L2
CDSOT236-DSL0324.....	L4

How to Order

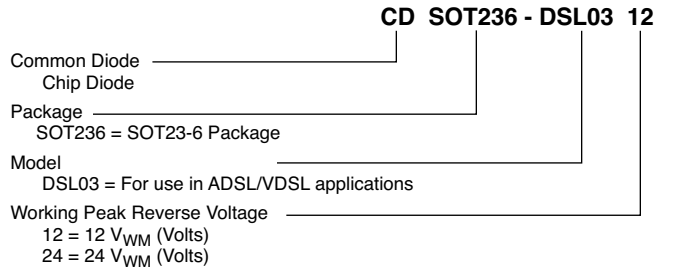

CDSOT236-DSL03xx - TVS Diode Array Series

BOURNS®

Packaging Information

The product is packaged in tape and reel format per EIA-481 standard.

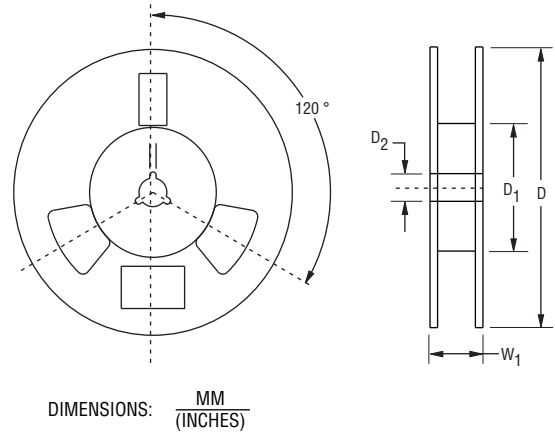
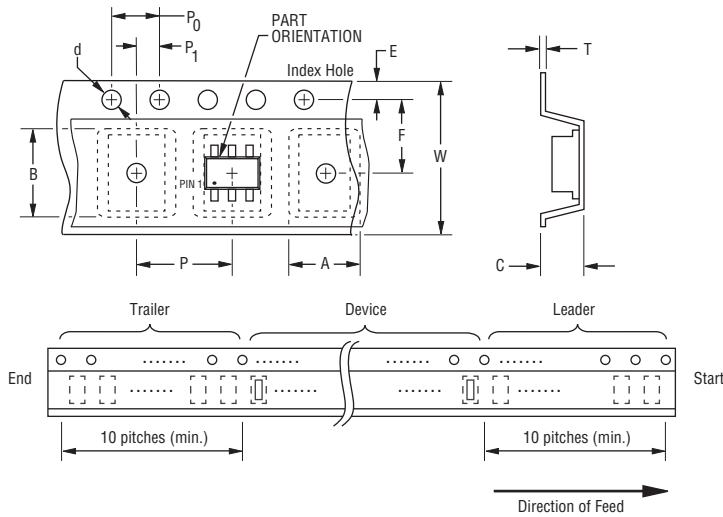

Item	Symbol	SOT23-6
Carrier Width	A	$\frac{3.90 \pm 0.10}{(0.154 \pm 0.004)}$
Carrier Length	B	$\frac{3.90 \pm 0.10}{(0.154 \pm 0.004)}$
Carrier Depth	C	$\frac{0.90 \pm 0.10}{(0.035 \pm 0.004)}$
Sprocket Hole	d	$\frac{1.55 \pm 0.05}{(0.061 \pm 0.002)}$
Reel Outside Diameter	D	$\frac{178}{(7.008)}$
Reel Inner Diameter	D ₁	$\frac{50.0}{(1.969)}$ MIN.
Feed Hole Diameter	D ₂	$\frac{13.0 \pm 0.20}{(0.512 \pm 0.008)}$
Sprocket Hole Position	E	$\frac{1.75 \pm 0.10}{(0.069 \pm 0.004)}$
Punch Hole Position	F	$\frac{3.50 \pm 0.05}{(0.138 \pm 0.002)}$
Punch Hole Pitch	P	$\frac{4.00 \pm 0.10}{(0.157 \pm 0.004)}$
Sprocket Hole Pitch	P ₀	$\frac{4.00 \pm 0.10}{(0.157 \pm 0.004)}$
Embossment Center	P ₁	$\frac{2.00 \pm 0.05}{(0.079 \pm 0.002)}$
Overall Tape Thickness	T	$\frac{0.20 \pm 0.10}{(0.008 \pm 0.004)}$
Tape Width	W	$\frac{8.00 \pm 0.20}{(0.315 \pm 0.008)}$
Reel Width	W ₁	$\frac{14.4}{(0.567)}$ MAX.
Quantity per Reel	--	3000

BOURNS®

Asia-Pacific: Tel: +886-2 2562-4117 • Fax: +886-2 2562-4116

Europe: Tel: +41-41 768 5555 • Fax: +41-41 768 5510

The Americas: Tel: +1-951 781-5500 • Fax: +1-951 781-5700

www.bourns.com

05/13

Specifications are subject to change without notice. The device characteristics and parameters in this data sheet can and do vary in different applications and actual device performance may vary over time. Users should verify actual device performance in their specific applications.

Looking for pricing, stock, or lifecycle information?

Click below to explore more details on WIN SOURCE:

- ⊖ [View CDSOT236-DSL0312 on WIN SOURCE](#)
- ⊖ [Bourns Inc. Information](#)

Optimize Your Supply Chain with WIN SOURCE Solutions

- ✓ Global Sourcing Solution
- ✓ Obsolete Management
- ✓ Cost Control Management
- ✓ Shortage Management
- ✓ Alternative Solution
- ✓ Excess Inventory Management