



**THE DATASHEET OF
BGS18MA14E6327XTSA1**



BGS18MA14

MIPI 2.0 SP8T switch for LTE Rx and Tx applications up to 3.8GHz

Key Features

- 0.1 to 3.8 GHz coverage for LTE application up to Band 43
- LTE TX power handling capabilities
- Ultra low insertion loss: 0.5dB for Band 41 and 0.7dB for Band 43
- Small form factor 2.0mm x 2.0mm
- Fully compatible with MIPI 2.0 RFFE standard
- No decoupling capacitors required (Unless DC applied on RF lines)

Applications

The SP8T switch is a band selection switch for LTE applications. With LTE TX power handling capability it is suitable for both LTE diversity path and LTE uplink Tx applications. The switch covers up to 3.8GHz so it supports Band 42 and Band 43.

Product Validation

Qualified for industrial applications according to the relevant tests of JEDEC47/20/22.

Block diagram

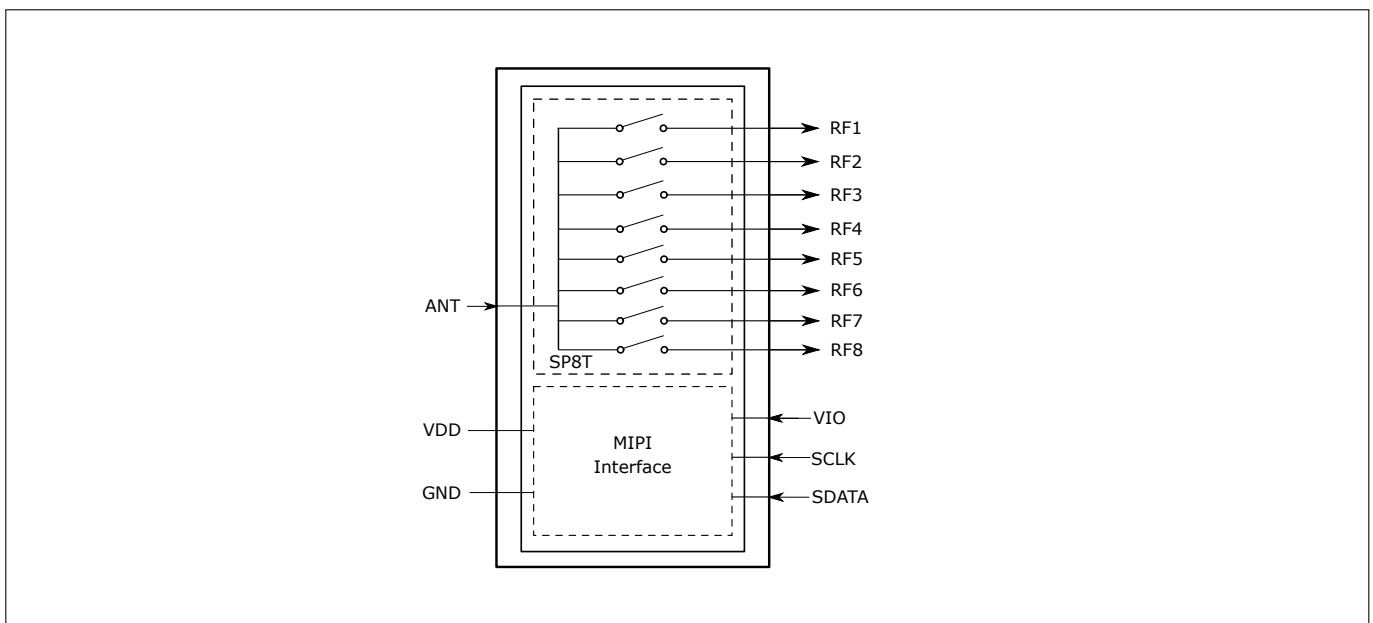

BGS18MA14

MIPI 2.0 SP8T switch for LTE Rx and Tx applications up to 3.8GHz

Table of Contents

Table of Contents

Table of Contents	1
1 Features	2
2 Maximum Ratings	3
3 Operation ranges	4
4 RF Characteristics	5
5 MIPI RFFE Specification	7
6 Package related information	11

BGS18MA14

MIPI 2.0 SP8T switch for LTE Rx and Tx applications up to 3.8GHz

Features

1 Features

- 0.1 to 3.8 GHz coverage for LTE application up to Band 43
- Suitable for LTE / WCDMA / TDCDMA Applications
- LTE TX Power Handling Capabilities
- Ultra low insertion loss: 0.5dB for Band 41 and 0.7dB for Band 43
- Small form factor 2.0mm x 2.0mm
- Fully compatible with MIPI 2.0 RFFE standard
- No decoupling capacitors required (Unless DC applied on RF lines)
- Low harmonic generation
- High port-to-port-isolation
- On chip control logic including ESD protection
- No power supply blocking required
- High EMI robustness
- RoHS and WEEE compliant package

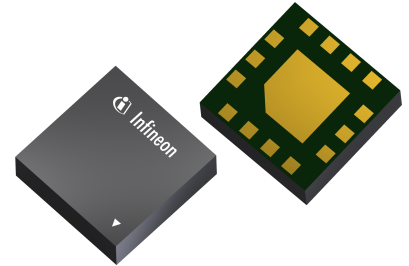

Description

This SP8T RF switch is a perfect solution for multimode handsets based on LTE, WCDMA and TDCDMA. It is based on Infineon's proprietary technology and has excellent RF performance. The ultra-low insertion loss helps customers to achieve high system sensitivity, the coverage of LTE Tx power and 3.8GHz enables very broad application. It features DC-free RF ports, external DC blocking capacitors at the RF ports are only required if DC voltage is applied externally.

Product Name	Marking	Package
BGS18MA14	A1	ATSLP-14-10

BGS18MA14

MIPI 2.0 SP8T switch for LTE Rx and Tx applications up to 3.8GHz

Maximum Ratings

2 Maximum Ratings

Table 1: Maximum Ratings, Table I at $T_A = 25^\circ\text{C}$, unless otherwise specified

Parameter	Symbol	Values			Unit	Note / Test Condition
		Min.	Typ.	Max.		
Frequency Range	f	0.1	–	3.8	GHz	1)
Supply voltage ²⁾	V_{DD}	-0.5	–	3.9	V	–
RFFE supply voltage	V_{IO}	-0.5	–	2.5	V	–
RFFE input voltage (SCLK, SDATA)	V_I	-0.5	–	$V_{IO}+0.5$	V	–
Storage temperature range	T_{STG}	-55	–	150	°C	–
RF input power at all TRx ports	P_{RF_max}	–	–	35	dBm	Short momentary, 50Ω
ESD capability, CDM ³⁾	V_{ESD_CDM}	-500	–	+500	V	
ESD capability, HBM ⁴⁾	V_{ESD_HBM}	-1	–	+1	kV	
ESD capability, system level (RF port) ⁵⁾	V_{ESD_ANT}	-8	–	+8	kV	ANT vs system GND, with 27 nH shunt inductor
Junction temperature	T_j	–	–	125	°C	–

¹⁾ Switch has a low-pass response. For higher frequencies, losses have to be considered for their impact on thermal heating. The DC voltage at RF ports V_{RFDC} has to be 0V.

²⁾ Note: Consider potential ripple voltages on top of V_{DD} . Including RF ripple, V_{DD} must not exceed the maximum ratings: $V_{DD} = V_{DC} + V_{Ripple}$.

³⁾ Field-Induced Charged-Device Model ANSI/ESDA/JEDEC JS-002. Simulates charging/discharging events that occur in production equipment and processes. Potential for CDM ESD events occurs whenever there is metal-to-metal contact in manufacturing.

⁴⁾ Human Body Model ANSI/ESDA/JEDEC JS-001 ($R = 1,5\text{ k}\Omega$, $C = 100\text{ pF}$).

⁵⁾ IEC 61000-4-2 ($R = 330\ \Omega$, $C = 150\text{ pF}$), contact discharge.

Warning: Stresses above the max. values listed here may cause permanent damage to the device. Maximum ratings are absolute ratings; exceeding only one of these values may cause irreversible damage to the integrated circuit. Exposure to conditions at or below absolute maximum rating but above the specified maximum operation conditions may affect device reliability and life time. Functionality of the device might not be given under these conditions.

Table 2: Maximum Ratings, Table II at $T_A = 25^\circ\text{C}$, unless otherwise specified

Parameter	Symbol	Values			Unit	Note / Test Condition
		Min.	Typ.	Max.		
Thermal resistance junction - soldering point	R_{thJS}	–	–	62	K/W	–
Maximum DC-voltage on RF-Ports and RF-Ground	V_{RFDC}	0	–	0	V	No DC voltages allowed on RF-Ports

BGS18MA14

MIPI 2.0 SP8T switch for LTE Rx and Tx applications up to 3.8GHz

Operation ranges

3 Operation ranges

Table 3: Operation ranges at $T_A = -40\text{ °C}$ to 85 °C

Parameter	Symbol	Values			Unit	Note / Test Condition
		Min.	Typ.	Max.		
Supply Voltage	V_{DD}	1.7	2.85	3.4	V	–
Supply Current	I_{DD}	–	60	125	μA	–
Supply Current in Standby mode	I_{BATT_SB}	–	0.5	1	μA	VIO=low or MIPI lowpower mode
RFFE supply voltage	V_{IO}	1.65	1.8	1.95	V	–
RFFE input high voltage ¹	V_{IH}	$0.7 \cdot V_{IO}$	–	V_{IO}	V	–
RFFE input low voltage ¹	V_{IL}	0	–	$0.3 \cdot V_{IO}$	V	–
RFFE output high voltage ¹	V_{OH}	$0.8 \cdot V_{IO}$	–	V_{IO}	V	–
RFFE output low voltage ¹	V_{OL}	0	–	$0.2 \cdot V_{IO}$	V	–
RFFE control input capacitance	C_{Ctrl}	–	–	2	pF	–
RFFE supply current	I_{VIO}	–	2	–	μA	Idle State
VIO supply rise time	t_{VIO_rise}	50	–	450	μs	–
VIO supply reset time	t_{VIO_reset}	10	–	–	μs	–

¹SCLK and SDATA

Table 4: RF input power

Parameter	Symbol	Values			Unit	Note / Test Condition
		Min.	Typ.	Max.		
RF input power on TRX ports	P_{RF}	–	–	32	dBm	CW / VSWR 1:1 / 25 °C
RF input power on TRX ports	P_{RF}	–	–	30	dBm	CW / VSWR 6:1 / 25 °C

RF Characteristics

4 RF Characteristics

Table 5: RF Characteristics at $T_A = -40\text{ }^{\circ}\text{C} \dots 85\text{ }^{\circ}\text{C}$, $P_{IN} = 0\text{ dBm}$, Supply Voltage $V_{DD} = 1.7\text{V} \dots 3.4\text{V}$, unless otherwise specified.
Open ports are terminated with $50\ \Omega$

Parameter	Symbol	Values			Unit	Note / Test Condition
		Min.	Typ.	Max.		
Insertion Loss¹⁾						
All TRx Ports	IL	-	0.30	0.40	dB	698–960 MHz
		-	0.35	0.55	dB	1428–1920 MHz
		-	0.40	0.65	dB	1990–2170 MHz
		-	0.50	0.70	dB	2170–2690 MHz
		-	0.67	0.95	dB	3400–3600 MHz
		-	0.70	1.00	dB	3600–3800 MHz
Return Loss¹⁾						
All TRx Ports	RL	19	23	-	dB	698–960 MHz
		14	17	-	dB	1428–1920 MHz
		13	16	-	dB	1990–2170 MHz
		12	16	-	dB	2170–2690 MHz
		10	16	-	dB	3400–3600 MHz
		10	15	-	dB	3600–3800 MHz
Isolation^{1) 2)}						
Adjacent TRx Ports	ISO	32	45	-	dB	698–960 MHz
		26	37	-	dB	1428–1920 MHz
		24	35	-	dB	1990–2170 MHz
		22	34	-	dB	2170–2690 MHz
		19	30	-	dB	3400–3600 MHz
		17	29	-	dB	3600–3800 MHz
Non adjacent TRx Ports	ISO	32	50	-	dB	698–960 MHz
		28	45	-	dB	1428–1920 MHz
		26	42	-	dB	1990–2170 MHz
		24	40	-	dB	2170–2690 MHz
		22	38	-	dB	3400–3600 MHz
		22	35	-	dB	3600–3800 MHz
Harmonic Generation (UMTS Band 1, Band 5)¹⁾						
2 nd harmonic generation	P_{H2}	-	-80	-70	dBm	27 dBm, 50 Ω , CW mode
3 rd harmonic generation	P_{H3}	-	-60	-55	dBm	27 dBm, 50 Ω , CW mode
Intermodulation Distortion (UMTS Band 1, Band 5)¹⁾						
2 nd order intermodulation	IMD2 low	-	-	-110	dBm	IMT, US Cell (see Tab. 7)
3 rd order intermodulation	IMD3	-	-	-105	dBm	IMT, US Cell (see Tab. 8)
2 nd order intermodulation	IMD2 high	-	-	-110	dBm	IMT, US Cell (see Tab. 7)
Input Intercept point (UMTS Band 1, Band 5)¹⁾						
2 nd order intercept point	IIP2	110	-	-	dBm	IMT, US Cell (see Tab. 7)
3 rd order intercept point	IIP3	65	-	-	dBm	IMT, US Cell (see Tab. 8)

¹⁾On application board without any matching components.

²⁾Isolation to inactive ports when one path is active.

BGS18MA14

MIPI 2.0 SP8T switch for LTE Rx and Tx applications up to 3.8GHz

RF Characteristics

Table 6: Switching Time at $T_A = 25\text{ }^\circ\text{C}$, $P_{IN} = 0\text{ dBm}$, Supply Voltage $V_{DD} = 1.7\text{...}3.4\text{V}$, unless otherwise specified

Parameter	Symbol	Values			Unit	Note / Test Condition
		Min.	Typ.	Max.		
Switching Time						
RF Rise Time	t_{RT}	-	-	2	μs	10 % to 90 % RF signal
Switching Time	t_{ST}	-	3	4.5	μs	50% last SCLK falling edge to 90% RF signal, see Fig. 1
Power Up Settling Time	t_{Pup}	-	-	25	μs	After power down mode ¹⁾

¹⁾ Don't change switch state during first 10 μs of power-up.

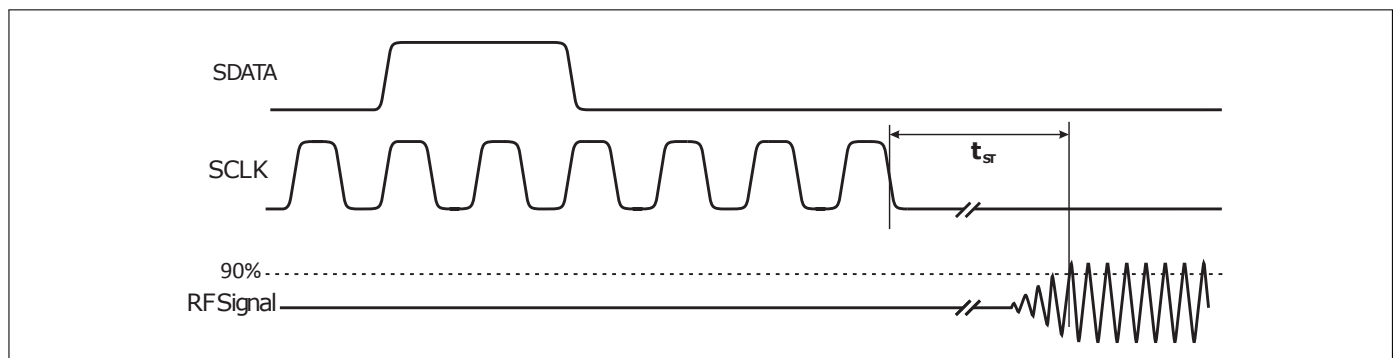

Figure 1: MIPI to RF time

Table 7: IMD2 Testcases

Band	CW tone 1 (MHz)	CW tone 1 (dBm)	CW tone 2 (MHz)	CW tone 2 (dBm)
IMT	1950	20	190 (IMD2 low)	-15
			4090 (IMD2 high)	
US Cell	835	20	45 (IMD2 low)	-15
			1715 (IMD2 high)	

Table 8: IMD3 Testcases

Band	CW tone 1 (MHz)	CW tone 1 (dBm)	CW tone 2 (MHz)	CW tone 2 (dBm)
IMT	1950	20	1760	-15
US Cell	835	20	790	-15

BGS18MA14

MIPI 2.0 SP8T switch for LTE Rx and Tx applications up to 3.8GHz

MIPI RFFE Specification

5 MIPI RFFE Specification

All sequences are implemented according to the 'MIPI Alliance Specification for RF Front-End Control Interface' document version 2.0 - 25. September 2014.

Table 9: MIPI Features

Feature	Supported	Comment
MIPI RFFE 1.10 and 2.0 standards	Yes	
Register 0 write command sequence	Yes	
Register read and write command sequence	Yes	
Extended register read and write command sequence	Yes	
Support for standard frequency range operations for SCLK	Yes	Up to 26 MHz for read and write
Support for extended frequency range operations for SCLK	Yes	Up to 52 MHz for write ¹⁾
Half speed read	Yes	
Full speed read	Yes	
Full speed write	Yes	
Programmable Group SID	Yes	
Trigger functionality	Yes	
Broadcast / GSID write to PM TRIG register	Yes	
Reset	Yes	Via VIO, PM TRIG or software register ¹⁾
Status / error sum register	Yes	
Extended product ID register	Yes	
Revision ID register	Yes	
Group SID register	Yes	
USID_Sel pin	No	External pin for changing USID is not implemented

¹⁾ only supported by MIPI 2.0 Standard

Table 10: Startup Behavior

Feature	State	Comment
Power status	Power down mode	Power down mode after start-up
Trigger function	Enabled	Enabled after start-up. Programmable via behavior control register

MIPI RFFE Specification

Table 11: Register Mapping, Table I

Register Address	Register Name	Data Bits	Function	Description	Default	Broadcast_ID Support	Trigger Support	R/W	
0x00	SW_CTRL0	6:0	SW_CTRL0	RF Switch Control	0	No	Yes	R/W	
0x1C	PM_TRIG	7	PWR_MODE(1), Operation Mode	0: Normal operation (ACTIVE)	1	Yes	No	R/W	
				1: Low Power Mode (LOW POWER)					
		6	PWR_MODE(0), State Bit Vector	0: No action (ACTIVE)	0				
				1: Powered Reset (STARTUP to ACTIVE to LOW POWER)					
		5	TRIGGER_MASK_2	0: Data masked (held in shadow REG)	0				No
				1: Data not masked (ready for transfer to active REG)					
		4	TRIGGER_MASK_1	0: Data masked (held in shadow REG)	0				
				1: Data not masked (ready for transfer to active REG)					
		3	TRIGGER_MASK_0	0: Data masked (held in shadow REG)	0				
1: Data not masked (ready for transfer to active REG)									
2	TRIGGER_2	0: No action (data held in shadow REG)	0	Yes					
		1: Data transferred to active REG							
1	TRIGGER_1	0: No action (data held in shadow REG)	0						
		1: Data transferred to active REG							
0	TRIGGER_0	0: No action (data held in shadow REG)	0						
		1: Data transferred to active REG							
0x1D	PRODUCT_ID	7:0	PRODUCT_ID		This is a read-only register. However, during the programming of the USID a write command sequence is performed on this register, even though the write does not change its value.	0xCB	No	No	R
0x1E	MAN_ID	7:0	MANUFACTURER_ID [7:0]		This is a read-only register. However, during the programming of the USID, a write command sequence is performed on this register, even though the write does not change its value.	0x1A	No	No	R
0x1F	MAN_USID	7:6	RESERVED		Reserved for future use	00	No	No	R
		5:4	MANUFACTURER_ID [9:8]	These bits are read-only. However, during the programming of the USID, a write command sequence is performed on this register even though the write does not change its value.	01				
		3:0	USID[3:0]	Programmable USID. Performing a write to this register using the described programming sequences will program the USID in devices supporting this feature. These bits store the USID of the device.	0x8	No	No	R/W	

MIPI RFFE Specification

Table 12: Register Mapping, Table II

Register Address	Register Name	Data Bits	Function	Description	Default	Broadcast_ID Support	Trigger Support	R/W
0x20	EXT_PROD_ID ¹⁾	7:0	EXT_PRODUCT_ID		0x00	No	No	R
0x21	REV_ID	7:4	MAIN_REVISION		0x4	No	No	R/W
		3:0	SUB_REVISION		0x0			
0x22	GSID ¹⁾	7:4	GSID0[3:0]	Primary Group Slave ID.	0x0	No	No	R/W
		3:0	RESERVED	Reserved for secondary Group Slave ID.	0x0			
0x23	UDR_RST	7	UDR_RST	Reset all configurable non-RFFE Reserved registers to default values. 0: Normal operation 1: Software reset	0	No	No	R/W
		6:0	RESERVED	Reserved for future use	0000000			
0x24	ERR_SUM ¹⁾	7	RESERVED	Reserved for future use	0	No	No	R
		6	COMMAND_FRAME_PAR_ERR	Command Sequence received with parity error – discard command.	0			
		5	COMMAND_LENGTH_ERR	Command length error.	0			
		4	ADDRESS_FRAME_PAR_ERR	Address frame with parity error.	0			
		3	DATA_FRAME_PAR_ERR	Data frame with parity error.	0			
		2	READ_UNUSED_REG	Read command to an invalid address.	0			
		1	WRITE_UNUSED_REG	Write command to an invalid address.	0			
0	BID_GID_ERR	Read command with a BROADCAST_ID or GROUP_ID.	0					

¹⁾Only supported by MIPI 2.0 Standard

Table 13: Modes of Operation (Truth Table, Register_0)

State ¹⁾	Value (Bin.)	Mode
0	00000000	ALL OFF (Isolation)
1	00000010	RF1 ON
2	00001010	RF2 ON
3	00001110	RF3 ON
4	00001011	RF4 ON
5	00000001	RF5 ON
6	00001001	RF6 ON
7	00000110	RF7 ON
8	00000100	RF8 ON

¹⁾ Chip state is 0 (isolation) in unused states

BGS18MA14

MIPI 2.0 SP8T switch for LTE Rx and Tx applications up to 3.8GHz

Package related information

6 Package related information

The switch has a package size of 2000 μm in x-dimension and 2000 μm in y-dimension with a maximum deviation of $\pm 50 \mu\text{m}$ in each dimension. Fig. 2 shows the footprint from top view. The definition of each pin can be found in Tab. 15.

Table 14: Mechanical Data

Parameter	Symbol	Value	Unit
Package X-Dimension	X	2000 \pm 50	μm
Package Y-Dimension	Y	2000 \pm 50	μm
Package Height	H	0.65 max	μm

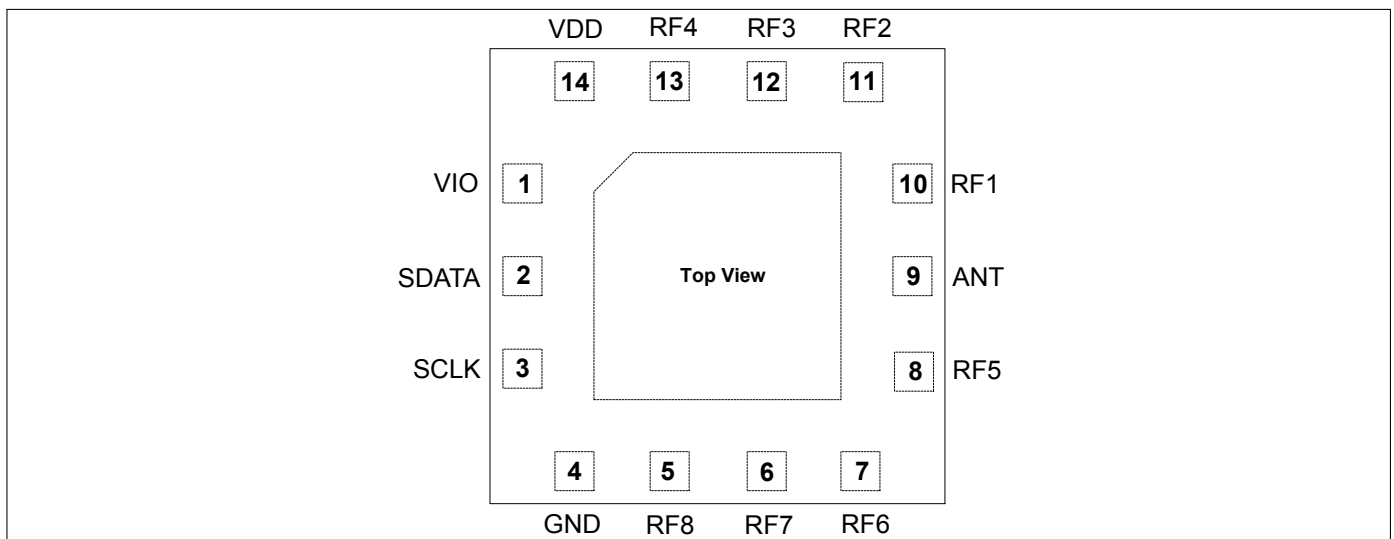

Figure 2: Footprint, top view

Table 15: Pin Definition

No.	Name	Pin Type	Function
1	VIO	Power	MIPI RFFE Power Supply
2	SDATA	I/O	MIPI RFFE Data I/O
3	SCLK	I/O	MIPI RFFE Clock
4	GND	Ground	Ground
5	RF8	RF	RF-Port TRX No. 8
6	RF7	RF	RF-Port TRX No. 7
7	RF6	RF	RF-Port TRX No. 6
8	RF5	RF	RF-Port TRX No. 5
9	ANT	RF	RF Antenna Port
10	RF1	RF	RF-Port TRX No. 1
11	RF2	RF	RF-Port TRX No. 2
12	RF3	RF	RF-Port TRX No. 3
13	RF4	RF	RF-Port TRX No. 4
14	VDD	Power	Power Supply

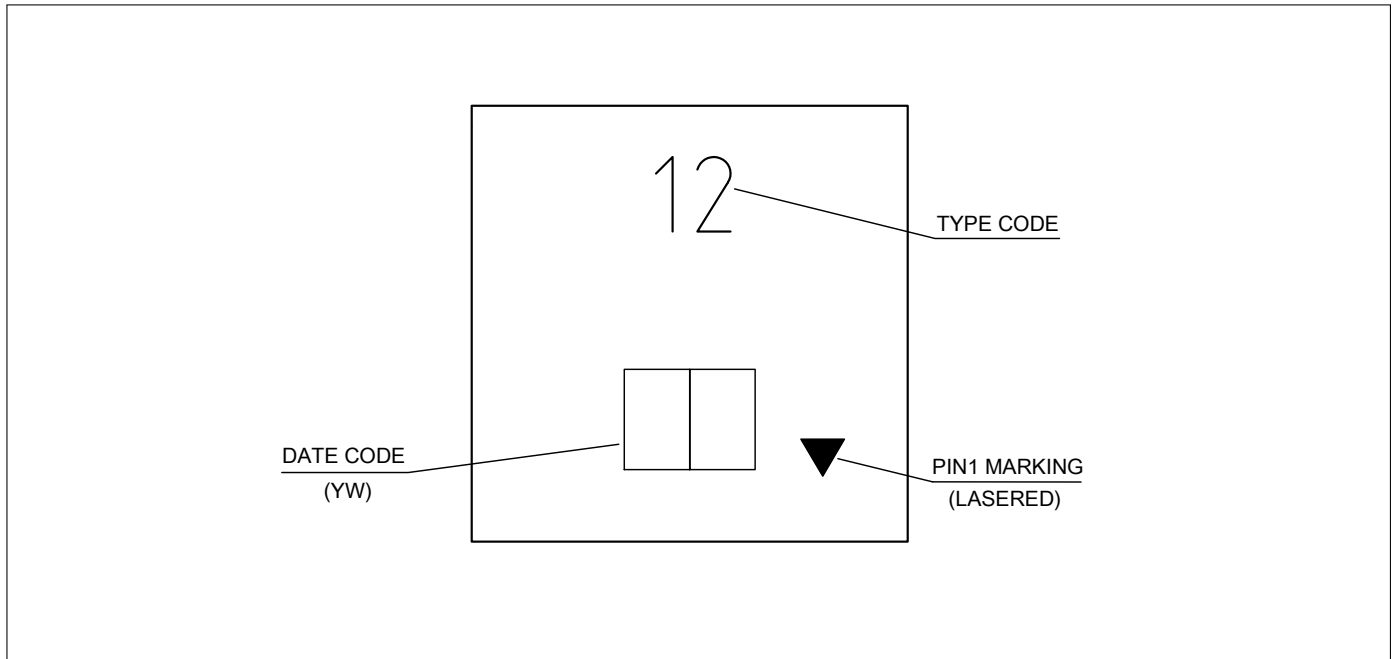

Figure 5: Laser marking

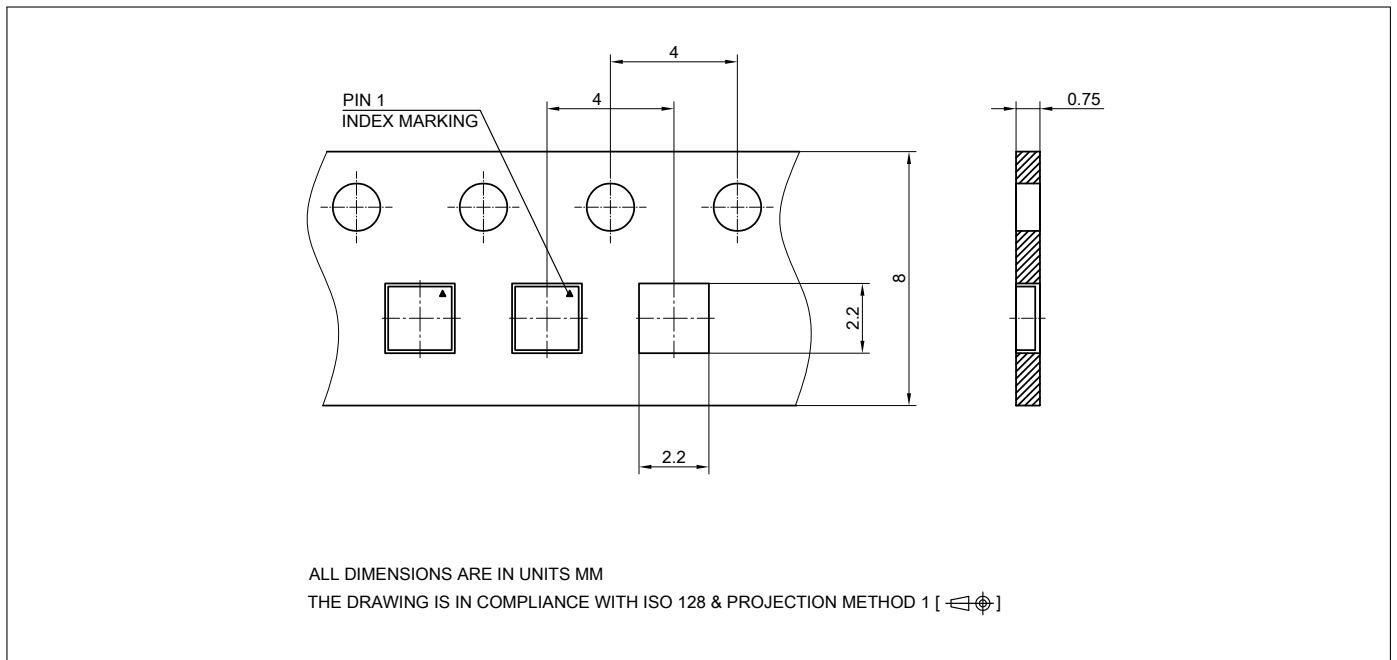

Figure 6: Carrier Tape

Table 16: Year date code marking - digit "Y"

Year	"Y"	Year	"Y"
2010	0	2020	0
2011	1	2021	1
2012	2	2022	2
2013	3	2023	3
2014	4	2024	4
2015	5	2025	5
2016	6	2026	6
2017	7	2027	7
2018	8	2028	8
2019	9	2029	9

Table 17: Week date code marking - digit "W"

Week	"W"	Week	"W"	Week	"W"	Week	"W"	Week	"W"
1	A	12	N	23	4	34	h	45	v
2	B	13	P	24	5	35	j	46	x
3	C	14	Q	25	6	36	k	47	y
4	D	15	R	26	7	37	l	48	z
5	E	16	S	27	a	38	n	49	8
6	F	17	T	28	b	39	p	50	9
7	G	18	U	29	c	40	q	51	2
8	H	19	V	30	d	41	r	52	3
9	J	20	W	31	e	42	s		
10	K	21	Y	32	f	43	t		
11	L	22	Z	33	g	44	u		

Revision History

Page or Item	Subjects (major changes since previous revision)
--------------	--

Revision 2.4, 2018-09-10	
--------------------------	--

	NDA removed.
--	--------------

Trademarks

All referenced product or service names and trademarks are the property of their respective owners.

Edition 2018-09-10

Published by

Infineon Technologies AG

81726 Munich, Germany

© 2018 Infineon Technologies AG.

All Rights Reserved.

Do you have a question about any aspect of this document?

Email: erratum@infineon.com

IMPORTANT NOTICE

The information given in this document shall in no event be regarded as a guarantee of conditions or characteristics ("Beschaffheitsgarantie"). With respect to any examples, hints or any typical values stated herein and/or any information regarding the application of the product, Infineon Technologies hereby disclaims any and all warranties and liabilities of any kind, including without limitation warranties of non-infringement of intellectual property rights of any third party. In addition, any information given in this document is subject to customer's compliance with its obligations stated in this document and any applicable legal requirements, norms and standards concerning customer's products and any use of the product of Infineon Technologies in customer's applications. The data contained in this document is exclusively intended for technically trained staff. It is the responsibility of customer's technical departments to evaluate the suitability of the product for the intended application and the completeness of the product information given in this document with respect to such application.

For further information on technology, delivery terms and conditions and prices, please contact the nearest Infineon Technologies Office (www.infineon.com).



WARNINGS

Due to technical requirements products may contain dangerous substances. For information on the types in question please contact your nearest Infineon Technologies office.



Except as otherwise explicitly approved by Infineon Technologies in a written document signed by authorized representatives of Infineon Technologies, Infineon Technologies products may not be used in any applications where a failure of the product or any consequences of the use thereof can reasonably be expected to result in personal injury.

Looking for pricing, stock, or lifecycle information?

Click below to explore more details on WIN SOURCE:

-  [View BGS18MA14E6327XTSA1 on WIN SOURCE](#)
-  [Infineon Technologies Information](#)

Optimize Your Supply Chain with WIN SOURCE Solutions

-  Global Sourcing Solution
-  Obsolete Management
-  Cost Control Management
-  Shortage Management
-  Alternative Solution
-  Excess Inventory Management