



**THE DATASHEET OF  
BGM13HBA9E6327XTSA1**



# Application Guide for Mobile Communication

**Edition 2018**



## About this Application Guide

This Application Guide for Mobile Communication describes recent trends in Mobile Radio Frequency (RF) applications and includes suggestions for using the latest Infineon products. It is a reference book to help mobile phone design experts to find the right parts easily for building high-performance RF Front Ends (FEs). The following subjects are covered within this guide:

1. Overview of Infineon Technologies AG's RF mobile product portfolio
2. RF switches in mobile phones and wireless systems
3. Antenna tuning switches for tunable mobile antenna systems
4. Low Noise Amplifiers (LNAs) and other RF devices for mobile phones
5. RF devices for Global Navigation Satellite Systems (GNSS)
6. RF devices for Wireless Local Area Networks (WLANs), unlicensed Long-Term Evolution (LTE-U) and Licensed Assisted Access (LAA)
7. RF devices for mobile FM radio and mobile TV
8. Electro-Static Discharge (ESD) protection devices for digital and RF interfaces in mobile communication devices

## Infineon Technologies

### A Leading Company in RF and Sensors

Infineon Technologies focuses on the three central challenges facing modern society: **Energy Efficiency, Mobility, Security and IoT & Big Data**. It offers semiconductor components and system solutions for automotive, consumer, industrial, power supplies, smart-card and security, and various other applications. Infineon's products stand out for their reliability, their quality and their innovative and leading-edge technologies in analog and mixed signal, RF and power, as well as embedded control. Please visit [www.infineon.com](http://www.infineon.com) to learn more about the broad product portfolio of Infineon Technologies.

With its technologies and design expertise, Infineon is the market leader in its chosen segments. Infineon has more than 60 years of experience in developing RF products for numerous applications and always plays a leading role delivering high-performance and cost-effective products to the market.

Infineon's Radio Frequency & Sensors (RFS) business unit has evolved over the years from supplying standard RF discrete components to providing an advanced portfolio of innovative and differentiated products including application-specific Microwave Monolithic Integrated Circuits (MMICs), millimeter-wave (mmW) transceivers, a large variety of high-end sensors and ESD protection components. RFS solutions for mobile device, cellular infrastructure, sensing, radar & 3D imaging applications shape the way we live and work. Please visit [www.infineon.com](http://www.infineon.com), and under "Products" follow the links "[RF & Wireless Control](#)", "[Sensor](#)" or "[ESD and Surge Protection](#)" to learn more.

The application guide for mobile communication is an easy-to-use tool primarily meant for engineers to guide you efficiently to the right devices for your systems. It is available for download at below website:

Application Guide for Mobile Communication: [www.infineon.com/appguide\\_rf\\_mobile](http://www.infineon.com/appguide_rf_mobile)

In this document, we have summarized the major available application circuits and their performance for the key application area Mobile Communication. For your convenience, the Internet product pages can be reached by simply clicking on any device name in the tables of recommended devices.

Our application experts worldwide are always ready to help you design your systems with our devices. Please contact [Infineon's Regional Offices](#) or one of [Infineon Worldwide Distribution Partners](#) in your area to get all the support you might need.

Kind regards,

Mathias Wolfmueller  
Head of Application Engineering  
RF Communication



Dr. Heinrich Heiss  
Head of Application Engineering  
3D-sensing & Discretes





## Table of Contents

Edition 2018 .....	1
<b>Infineon Technologies .....</b>	<b>1</b>
<b>1 Infineon’s RF and Protection Devices for Mobile Communication .....</b>	<b>5</b>
1.1 Key Trends in Mobile Communication .....	5
1.2 Infineon Product Portfolio for Mobile Phones and Wireless Systems.....	8
1.3 Infineon's Design-in Support .....	9
<b>2 Infineon’s RF FE Architecture for LTE Systems.....</b>	<b>11</b>
2.1 Infineon’s Single-Antenna RF FE Supporting up to 5 Downlink CA Solutions .....	11
2.2 Infineon’s Dual-Antenna RF FE Supporting up to 5 Downlink CA Solutions: .....	12
2.3 Infineon’s RF FE Supporting up to 2 Uplink CA Solutions:.....	13
2.3.2 Infineon’s Single-antenna RF FE CA Solution.....	14
2.3.3 Infineon’s Dual-antenna RF FE CA Solution .....	14
<b>3 High and Medium-Power Switches for Mobile Phones and Wireless Systems.....</b>	<b>16</b>
3.1 Key Challenges of Antenna Switches in Modern Mobile Applications .....	16
3.1.1 Mobile Industry Processor Interface (MIPI) for Mobile Phones .....	18
3.1.2 MIPI RF FE for RF Front-End Devices in Mobile Phones .....	18
3.1.3 Specification V2.10 of MIPI Alliance.....	20
3.2 High- and Medium-Power RF Switches .....	21
3.2.1 Ultra-High Linearity Switches.....	21
3.2.2 Diversity Antenna Switches .....	21
3.2.3 Band-selection Switches in a Single-ended Configuration .....	23
3.2.4 Cross Switches .....	24
3.3 Antenna Tuning Switches .....	25
3.3.1 Antenna Impedance Matching.....	25
3.3.2 Antenna Aperture Tuning .....	26
3.3.3 System Approach to Aperture Tuning.....	26
3.3.4 Key Parameters of Antenna Tuning Switches.....	27
3.4 PIN Diode Switches for Wireless Systems .....	31
<b>4 Low Noise Amplifiers for Mobile Phone RF Front-Ends.....</b>	<b>33</b>
4.1 Key Challenges of LNAs in Mobile Applications .....	34
4.2 Single-band LNAs and Multiple-band LNA Banks .....	35
4.2.1 Single-band LNAs .....	35
4.2.2 MIPI-RFFE LNA with Gain Control .....	36
4.3 LNA Multiplexer Modules (LMM) for Carrier Aggregation.....	37
4.4 LNAs for 3.5 GHz TD-LTE.....	39
<b>5 Global Navigation Satellite Systems.....</b>	<b>40</b>
5.1 Application and Technical Trends.....	40
5.2 Key Challenges for Modern GNSS Reception in Mobile Devices.....	41
5.3 Key Features of GNSS Front-End Devices.....	43
5.4 RF Front-End Devices for GNSS.....	44
<b>6 Wireless-LAN, Unlicensed LTE (LTE-U) and Licensed Assisted Access (LAA).....</b>	<b>45</b>
6.1 Wireless-LAN Applications .....	45
6.1.1 Key Features of WLAN Rx Front-End Devices .....	46

6.1.2	Dual-Band (2.4/5.0 GHz) WLAN (IEEE 802.11a/b/g/n) Front-End.....	47
6.1.3	MIMO Configurations for WLAN (IEEE 802.11b/g/n & IEEE 802.11a/n/ac) Applications .....	48
6.1.4	WLAN (IEEE 802.11a/b/g/n) Front-End Devices.....	49
6.2	Unlicensed LTE (LTE-U) and Licensed Assisted Access (LAA) .....	50
6.2.1	LTE-U and LAA as Data Rate Booster for LTE-A.....	50
6.2.2	LTE-U and LAA Front-End Devices .....	51
<b>7</b>	<b>FM Radio and Mobile TV .....</b>	<b>53</b>
7.1	FM Radio with Embedded Antenna .....	53
7.2	TV Reception in Mobile Phones .....	55
7.3	FM and TV Reception in Mobile Phones with Band Selection Switch .....	56
<b>8</b>	<b>Interface protection against ESD/Surge .....</b>	<b>57</b>
8.1	ESD Protection .....	57
8.2	Surge Protection for the Battery Charger Port.....	60
<b>Abbreviations .....</b>		<b>61</b>
<b>Alphanumerical List of Symbols.....</b>		<b>62</b>
<b>Package Information .....</b>		<b>63</b>
<b>Support Material.....</b>		<b>65</b>

### List of Figures<sup>1</sup>

Figure 1	Overview of Infineon’s products for mobile devices RF Frontend .....	8
Figure 2	Overview of Infineon’s ESD protection devices .....	9
Figure 3	Simulation test bench evaluating the effect of an Infineon RF FE on the system .....	10
Figure 4	Block diagram and implemented hardware for verification .....	10
Figure 5	Single-antenna downlink RF FE architecture for up to 5 CA’s.....	12
Figure 6	RF FE architecture for Dual-antenna downlink up to 5 CA’s.....	13
Figure 7	Block diagram of Inter-Band CA with single-antenna.....	14
Figure 8	Block diagram of Inter-Band CA with dual-antenna.....	14
Figure 9	CA Band 1 and Band 3 IMD analysis using system-level simulation.....	15
Figure 10	CA Band 1 and Band 3 IMD analysis using system level simulation .....	15
Figure 11	Typical RF FE in a mobile phone .....	17
Figure 12	Overview of MIPI interfaces on a mobile phone platform .....	19
Figure 13	Typical MIPI RFFE bus in a mobile phone.....	20
Figure 14	Example of MIPI RFFE interfaces in a mobile phone.....	20
Figure 15	Example of TD-LTE band for diversity path.....	21
Figure 16	Band switching with CMOS SPDT switch.....	23
Figure 17	LTE Band-1/Band-4 switching with CMOS SPDT switch .....	23
Figure 18	An example of cross switch application .....	24
Figure 19	Antenna impedance matching .....	25
Figure 20	Antenna aperture tuning.....	26
Figure 21	System diagram for antenna aperture tuning .....	26
Figure 22	Circuit diagram for aperture tuning .....	27
Figure 23	EM Simulation .....	27
Figure 24	Low voltage tuning case .....	28
Figure 25	High voltage tuning case.....	28
Figure 26	Low voltage tuning case .....	29

Figure 27	High voltage tuning case.....	29
Figure 28	Basic PIN diode switch configurations .....	31
Figure 29	Application a: Ultra-Low-Harmonic-Generation band switch with PIN-diodes.....	32
Figure 30	Application b,c: Antenna selection and length modification with PIN-diodes.....	32
Figure 31	Application d: Antenna tuning with PIN-diodes.....	32
Figure 32	Block diagram of a 3G/4G modem.....	33
Figure 33	Three single-band LNAs implemented in the diversity path .....	35
Figure 34	Multi gain state LNA implemented in the main path .....	36
Figure 35	LNA multiplexer module implemented in the diversity path .....	37
Figure 36	LNAs for 3.5 GHz TD-LTE.....	39
Figure 37	Frequency allocation GNSS systems, upper L bands and lower L bands .....	40
Figure 38	Noise figure desensitization effect caused by jammer signal .....	41
Figure 39	Block diagram for the LTE Band 13 second harmonic interference.....	42
Figure 40	GNSS system supporting L1 and L5 bands.....	44
Figure 41	Dual-band (2.4/5.0 GHz) WLAN (IEEE 802.11a/b/g/n) FE.....	47
Figure 42	Dual-band (2.4/5.0 GHz) WLAN (IEEE 802.11a/b/g/n) FE with bypass LNAs .....	47
Figure 43	Dual-band (2.4/5.0 GHz) WLAN (IEEE 802.11b/g/n and 802.11a/n/ac N x N MIMO FE with dual-band antennas, dual-band TX and RX paths using dual-band LNAs .....	48
Figure 44	LTE FDD operation supported by LAA and LTE-U techniques using link aggregation or CA.....	51
Figure 45	Block diagram of a 5-GHz LAA to support common FDD operation using CA.....	51
Figure 46	Application a: FM reception only .....	53
Figure 47	Application b: FM transmit/receive function block.....	54
Figure 48	Block diagram of a Mobile TV RF FE.....	55
Figure 49	Block diagram of a FM/Mobile TV RF FE with band selection switch .....	56
Figure 50	Interface protection with discrete ESD protection .....	58
Figure 51	Mobile device charging interface (Quick Charge, USB-PD) .....	60

### List of Tables

Table 1	LTE Uplink and Downlink Frequencies.....	7
Table 2	Summary of 802.11 a/b/g/n/ac/ad/af/ah Standards .....	45

# 1 Infineon's RF and Protection Devices for Mobile Communication

## 1.1 Key Trends in Mobile Communication

Mobile phones represent the largest worldwide market in terms of both volume and number of applications on a single platform. Currently about 1.5 billion smartphones are shipped per year worldwide. The major wireless functions in a typical mobile phone include a 2G/3G/4G (GSM/EDGE/CDMA/UMTS/WCDMA/LTE/LTE-A/TD-SCDMA/TD-LTE) cellular modem, and wireless connectivity systems such as Wireless Local Area Network (WLAN), Bluetooth, Global Navigation Satellite System (GNSS), broadcasting receivers, and Near-Field Communication (NFC).

Motivated by increasing demand for mobile broadband services with higher data rates and better quality of service, the mobile phone industry has seen tremendous growth in recent years from 3G/3.5G High-Speed Packet Access (HSPA), Evolved High-Speed Packet Access (HSPA+) to 3.9G Long-Term Evolution (LTE), recently 4G Long-Term Evolution Advanced (LTE-A) and 5G.

Moving towards LTE-A, the number of LTE bands has exploded. Currently, there are 56 LTE bands in use worldwide. Table 1, derived from the release of the 3rd Generation Partnership Project (3GPP) TS 36.101 V14.5.0 "Evolved Universal Terrestrial Radio Access (E-UTRA) - User Equipment (UE) radio transmission and reception" in November 2017, shows the LTE band numbers with uplink/downlink frequency ranges and their related multiplexing methods:

Band No.	Band Definition	Uplink Frequency Range	Downlink Frequency Range	FDD/TDD System	Comment
1	Mid-Band	1920-1980 MHz	2110-2170 MHz	FDD	
2	Mid-Band	1850-1910 MHz	1930-1990 MHz	FDD	
3	Mid-Band	1710-1785 MHz	1805-1880 MHz	FDD	
4	Mid-Band	1710-1755 MHz	2110-2155 MHz	FDD	
5	Low-Band	824-849 MHz	869-894 MHz	FDD	
6	Low-Band	830-840 MHz	875-885 MHz	FDD	
7	High-Band	2500-2570 MHz	2620-2690 MHz	FDD	
8	Low-Band	880-915 MHz	925-960 MHz	FDD	
9	Mid-Band	1749.9-1784.9 MHz	1844.9-1879.9 MHz	FDD	

# Application Guide for Mobile Communication

## Infineon's RF and Protection Devices for Mobile Communication



Band No.	Band Definition	Uplink Frequency Range	Downlink Frequency Range	FDD/TDD System	Comment
10	Mid-Band	1710-1770 MHz	2110-2170 MHz	FDD	
11	Mid-Band	1427.9-1452.9 MHz	1475.9-1500.9 MHz	FDD	
12	Low-Band	698-716 MHz	728-746 MHz	FDD	
13	Low-Band	777-787 MHz	746-756 MHz	FDD	
14	Low-Band	788-798 MHz	758-768 MHz	FDD	
15		reserved	reserved	FDD	
16		reserved	reserved	FDD	
17	Low-Band	704-716 MHz	734-746 MHz	FDD	
18	Low-Band	815-830 MHz	860-875 MHz	FDD	
19	Low-Band	830-845 MHz	875-890 MHz	FDD	
20	Low-Band	832-862 MHz	791-821 MHz	FDD	
21	Mid-Band	1447.9-1462.9 MHz	1495.9-1510.9 MHz	FDD	
22	High-Band	3410-3500 MHz	3510-3600 MHz	FDD	
23	Mid-Band	2000-2020 MHz	2180-2200 MHz	FDD	
24	Mid-Band	1626.5-1660.5 MHz	1525-1559 MHz	FDD	
25	Mid-Band	1850-1915 MHz	1930-1995 MHz	FDD	
26	Low-Band	814-849 MHz	859-894 MHz	FDD	
27	Low-Band	807-824 MHz	852-869 MHz	FDD	
28	Low-Band	703-748 MHz	758-803 MHz	FDD	
29	Low-Band	N/A	716-728 MHz	FDD	
30	High-Band	2305-2315 MHz	2350-2360 MHz	FDD	
31	Low-Band	452.5-457.5 MHz	462.5-467.5MHz	FDD	
32	Mid-Band	N/A	1452-1496 MHz	FDD	
33	Mid-Band	1900-1920 MHz		TDD	
34	Mid-Band	2010-2025 MHz		TDD	
35	Mid-Band	1850-1910 MHz		TDD	
36	Mid-Band	1930-1990 MHz		TDD	
37	Mid-Band	1910-1930 MHz		TDD	
38	High-Band	2570-2620 MHz		TDD	
39	Mid-Band	1880-1920 MHz		TDD	
40	High-Band	2300-2400 MHz		TDD	
41	High-Band	2496-2690 MHz		TDD	
42	High-Band	3400-3600 MHz		TDD	
43	High-Band	3600-3800 MHz		TDD	
44	Low-Band	703-803 MHz		TDD	
45	Mid-Band	1447-1467 MHz		TDD	

Band No.	Band Definition	Uplink Frequency Range	Downlink Frequency Range	FDD/TDD System	Comment
46	Ultra-High-Band	5150-5925 MHz		TDD	
47	Mid-Band	5855-5925 MHz		TDD	
48	Ultra-High-Band	3550- 3700 MHz		TDD	
...					
64		Reserved			
65	Mid-Band	1920-2010 MHz	2110-2200 MHz	FDD	
66	Mid-Band	1710-1780 MHz	2110-2200 MHz	FDD	
67	Low-Band	N/A	738-758 MHz	FDD	
68	Low-Band	698-728 MHz	753-783 MHz	FDD	
69	High-Band	N/A	2570-2620 MHz	FDD	
70	Mid-Band	1695 – 1710 MHz	1995-2020 MHz	FDD	
71	Low-Band	663-698 MHz	617-652 MHz	FDD	

Note: FDD - Frequency Division Duplexing; TDD - Time Division Duplexing.

**Table 1 LTE Uplink and Downlink Frequencies**

The ability of LTE-A to support single-carrier bandwidth up to 20 MHz and to have more spectral efficiency by using high-order modulation schemes such as Quadrature Amplitude Modulation (QAM-64) is of particular importance as the demand for higher wireless data speeds continues to grow rapidly. LTE-A can aggregate up to 5 carriers (up to 100 MHz) to increase user data rates and capacity for high-speed applications. These new techniques for mobile high-data-rate communication and advanced wireless connectivity include:

- Inter-operation Frequency-Division Duplexing (FDD) and Time-Division Duplexing (TDD)
- Down-/uplink Carrier Aggregation (CA)
- LTE-U and LAA at 5 to 6 GHz using link aggregation or carrier aggregation
- Adaptive antenna systems
- Multiple-Input Multiple-Output (MIMO)
- Device-to-Device (D2D) communication with LTE (LTE-D)
- High-speed wireline connection with USB 3.0, Bluetooth 4.0 etc.

The techniques mentioned above drive the industry to develop new concepts for RF Front-Ends and the antenna system and digital interface protection. These require microwave semiconductor vendors to offer highly integrated and compact devices with lower loss rates, and more powerful linear performance. The key trends in RF components for mobile phones are:

- Higher levels of integration with control buses
- Higher RF power capability

- Ability to handle increased number of bands and operating modes
- Better immunity to interfering signals
- Frequency-tuning ability
- Higher integration of various functions in single packages (modulation)

The coexistence of various wireless functions can make cross-functional interference much more complicated. Using our extensive knowledge about application trends, and our many industry contacts, we have designed our products to meet or exceed industry standards. This simplifies the design and makes choosing the right device easier for the system designers.

### 1.2 Infineon Product Portfolio for Mobile Phones and Wireless Systems

Infineon addresses requirements for high-performance RF devices by offering RF MMIC LNAs, RF CMOS switches, RF modules, antenna-tuning devices, RF couplers, RF transistors and diodes, and RF Electro-Static Discharge/Electromagnetic Interference (ESD/EMI). Infineon offers products for cellular modems, wireless connectivity functions, broadcasting receivers, sensors, ESD/EMI interface devices, etc. Figure 1 illustrates the product portfolio for mobile devices RF Frontend.

#### Overview of Infineon products for mobile devices

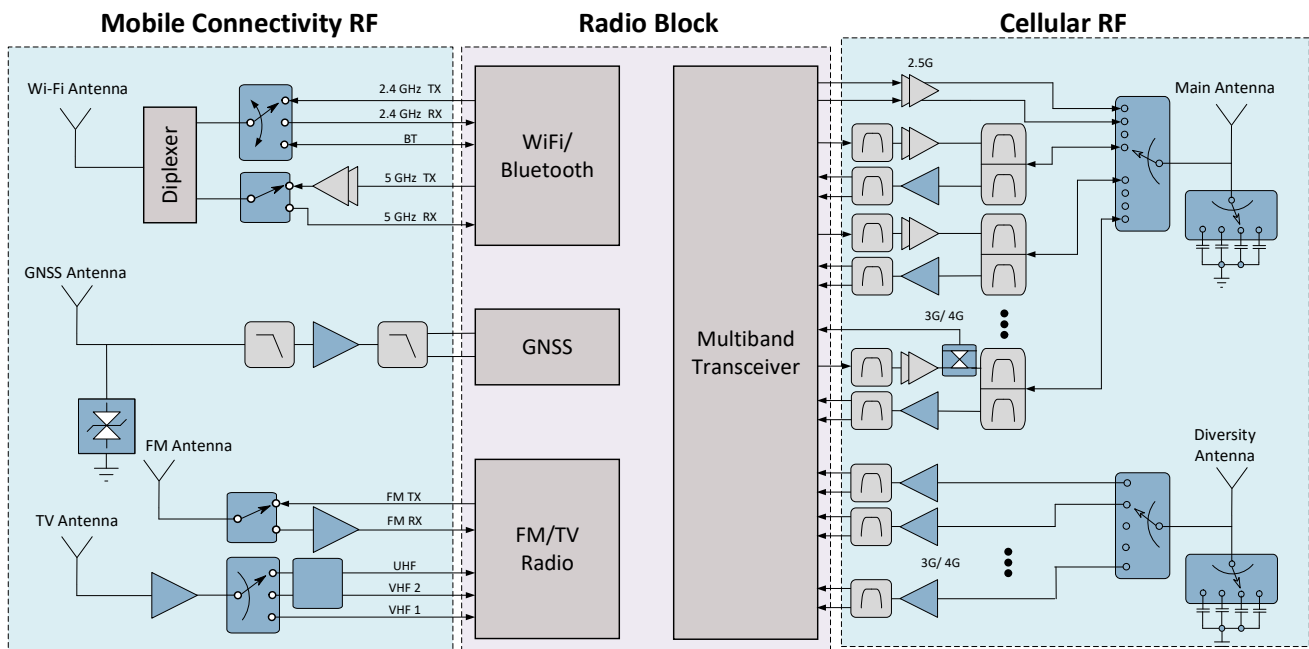
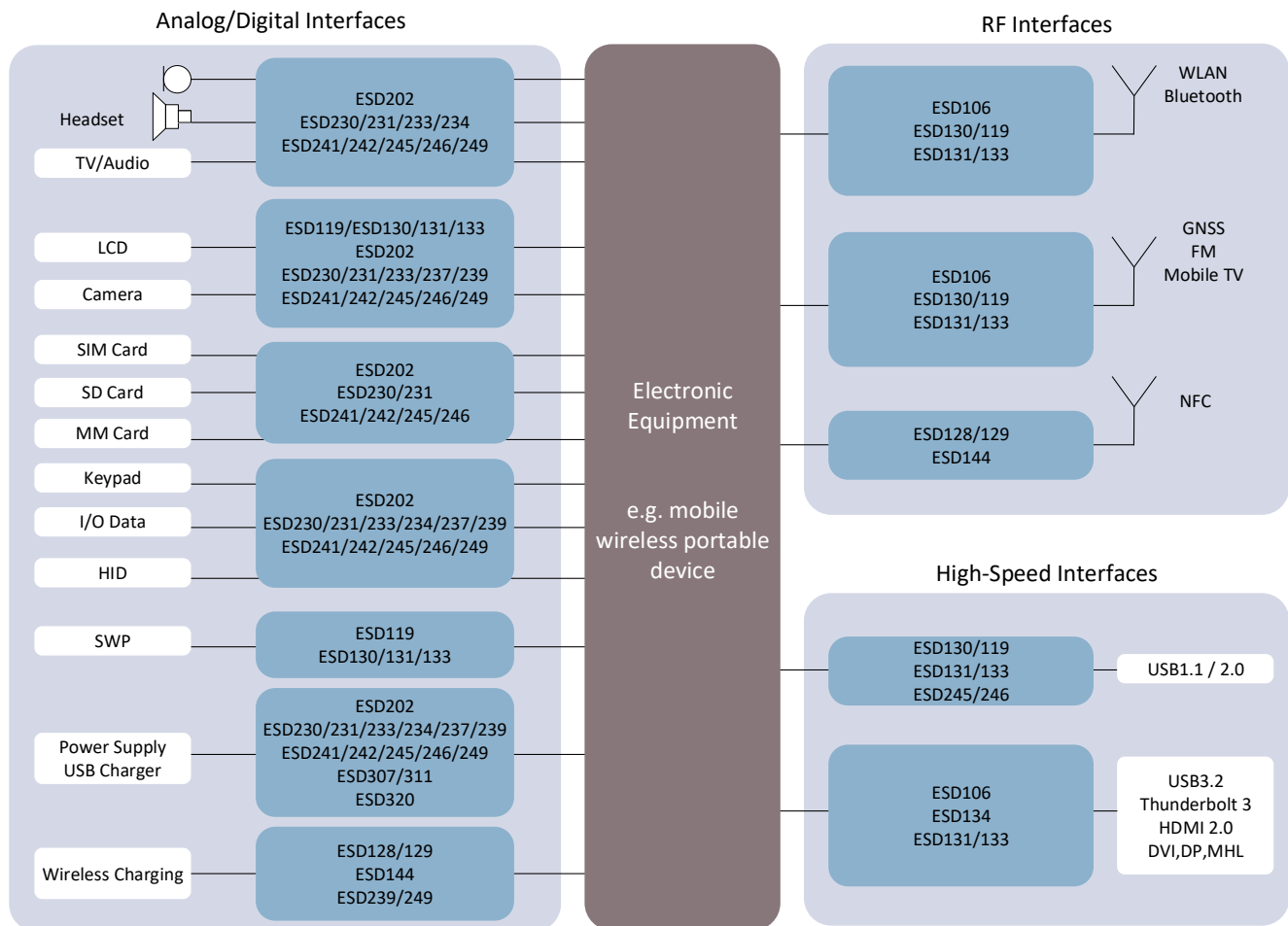

**Figure 1 Overview of Infineon's products for mobile devices RF Frontend**

All applications described in this document are depicted with simple block diagrams to show the various building blocks, followed by short descriptions. Infineon's recommended devices for each application are

tabulated together with their most important performance characteristics. More detailed information on each product is available at [www.infineon.com/rf](http://www.infineon.com/rf).

In addition to the above RF components, Infineon also provides XENSIV™ MEMS microphones for mobile devices, detailed information on each product is available at [www.infineon.com](http://www.infineon.com).

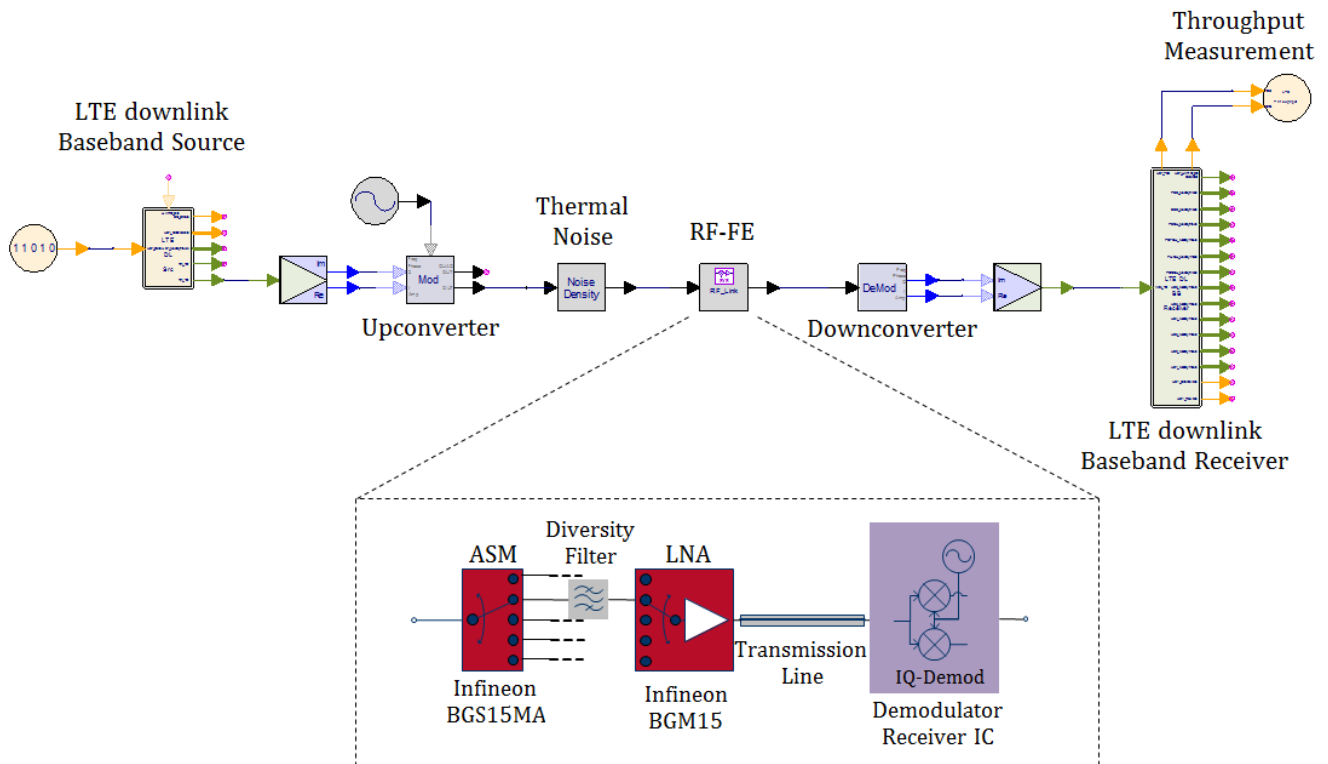

**Figure 2 Overview of Infineon's ESD protection devices**

### 1.3 Infineon's Design-in Support

Infineon provides design-in support for Infineon's RF devices and protection products. On the other hand, the team collaborates with its customers and partners on the mobile phone RF system level to define the best solution for their requirements. Infineon helps customers optimize system performance to reduce time-to-market by using complex system-level simulation tools, industry-leading system-level measurement equipment, and reference hardware designs for RF FE solutions.

An example is shown below. The Figure 3 illustrates a mobile diversity receiver simulation environment, and the Figure 4 shows the associated block diagrams and the hardware implemented for performance verification of the simulation results.



**Figure 3** Simulation test bench evaluating the effect of an Infineon RF FE on the system

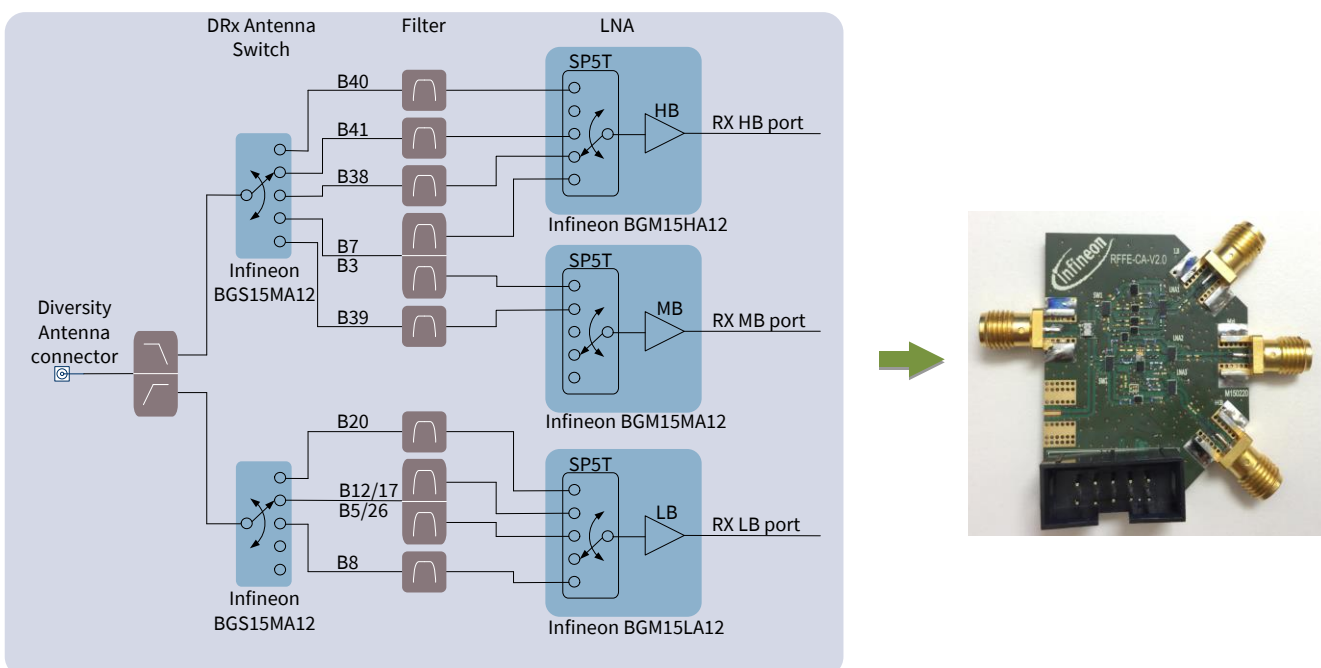

**Figure 4** Block diagram and implemented hardware for verification

## 2 Infineon's RF FE Architecture for LTE Systems

To meet the increasing market demand and to offer faster and better support, Infineon is working on several solutions to provide the appropriate device for the next generation LTE-A downlink FE. We are trying to optimize the performance of the whole system.

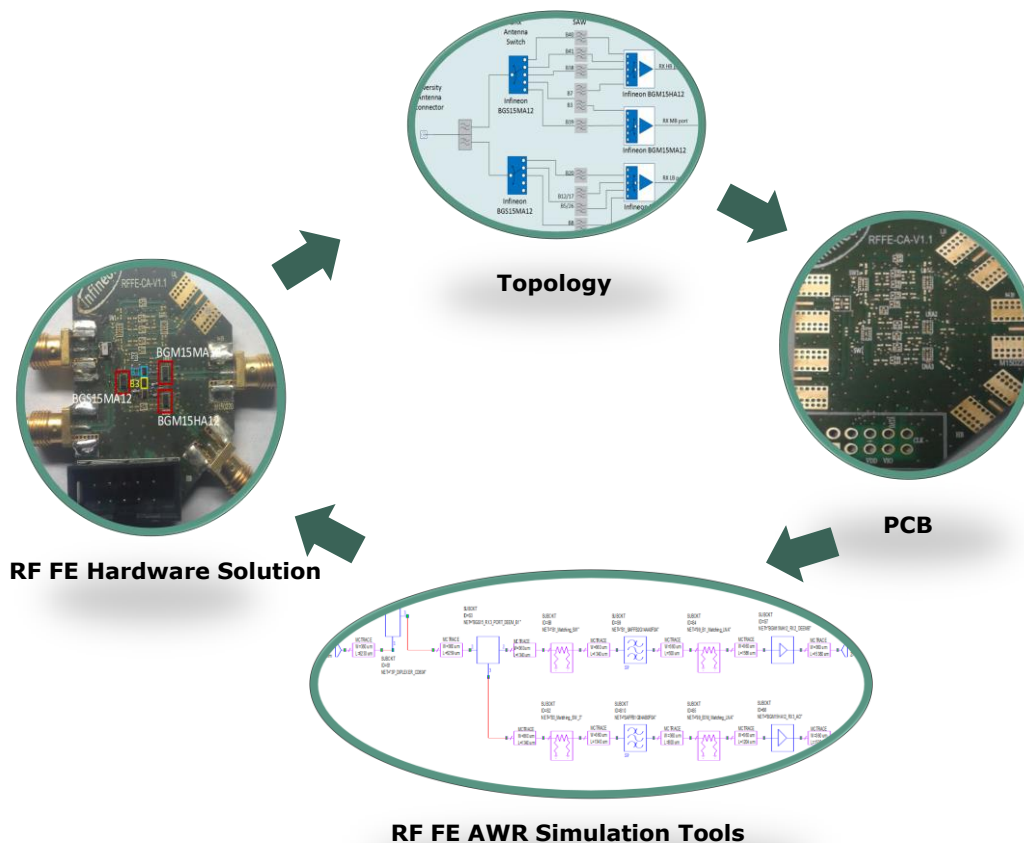

### 2.1 Infineon's Single-Antenna RF FE Supporting up to 5 Downlink CA Solutions

The solution presented in Figure 5 for single-antenna architecture is an example of the RF FE diversity topology including Carrier Aggregation (CA) for up to 5 downlink carrier components. By using a direct-mapping RF CMOS switch BGS15MA12 along with an adapted matching solution using single and dual SAW filters, it is possible to aggregate up to 3 inter-band component carriers with very good gain and noise performance. Customers who take this approach will have more flexibility to respond quickly and easily to market demands while using the same architecture.

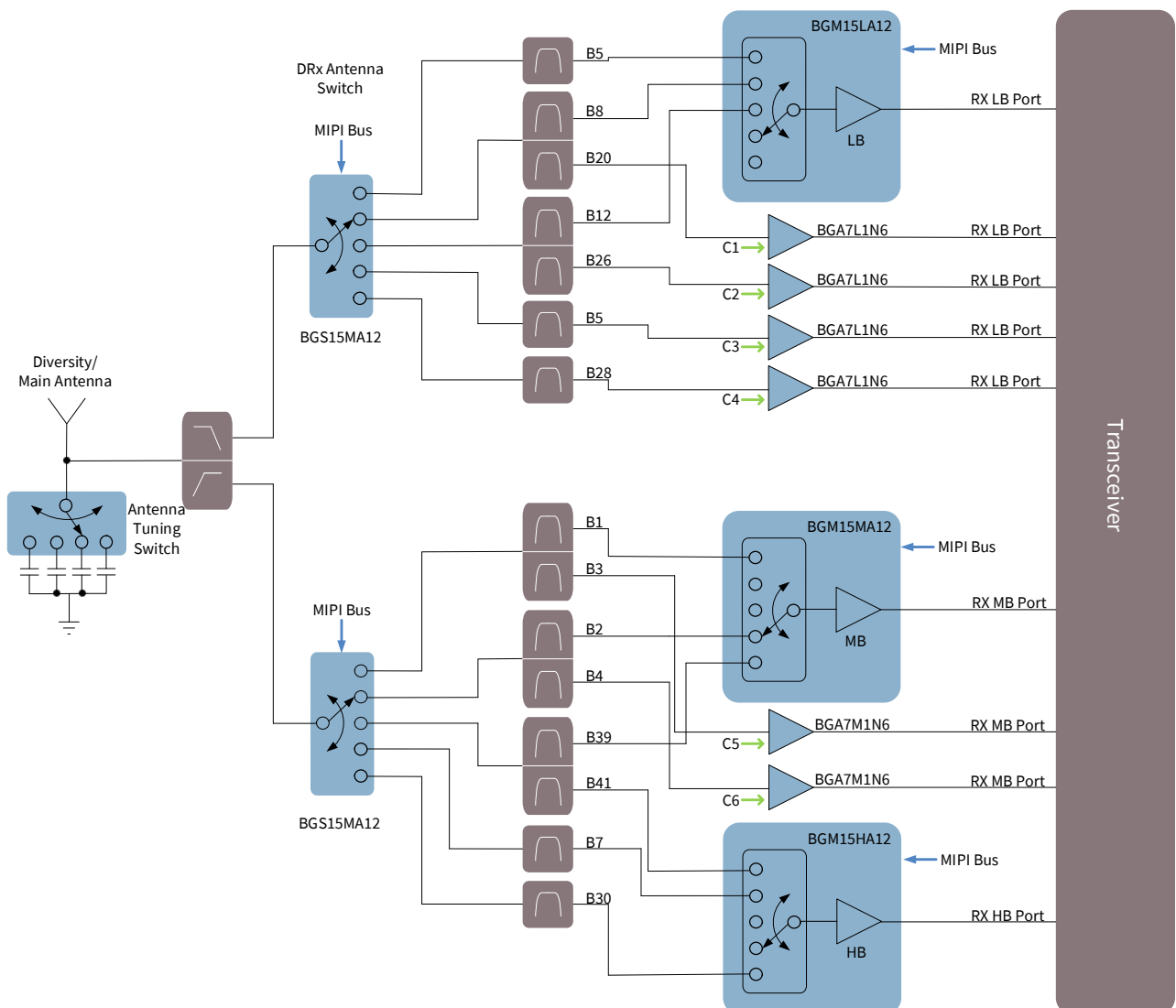

**Figure 5 Single-antenna downlink RF FE architecture for up to 5 CA's**

## 2.2 Infineon's Dual-Antenna RF FE Supporting up to 5 Downlink CA Solutions:

The solution presented below in Figure 6 supports Dual Diversity Antenna (DDA) architecture and up to 5 CA for downlinks. The key component of this topology is BGSX212MA18, the DP12T cross switch for antenna diversity. The cross switches connect two Rx ports simultaneously to the antenna with very good RF performance. The dual antenna input of these switches allows the direct connection to two different antennas (either broadband or frequency selective). By using the CA switching mode and a suitable matching solution with single and dual SAW filters this topology can support the aggregation of up to 3 inter-band carriers for each antenna input, with very good gain and noise performance.

Both topologies described above have dynamic operating modes because the aggregated bands are connected over the switches and the operating mode dynamically adapts depending on the requested service

and the options available within various networks. The combination of single-band LNAs and multiplexer module LNAs can improve the system sensitivity in a limited PCB area with low layout complexity.

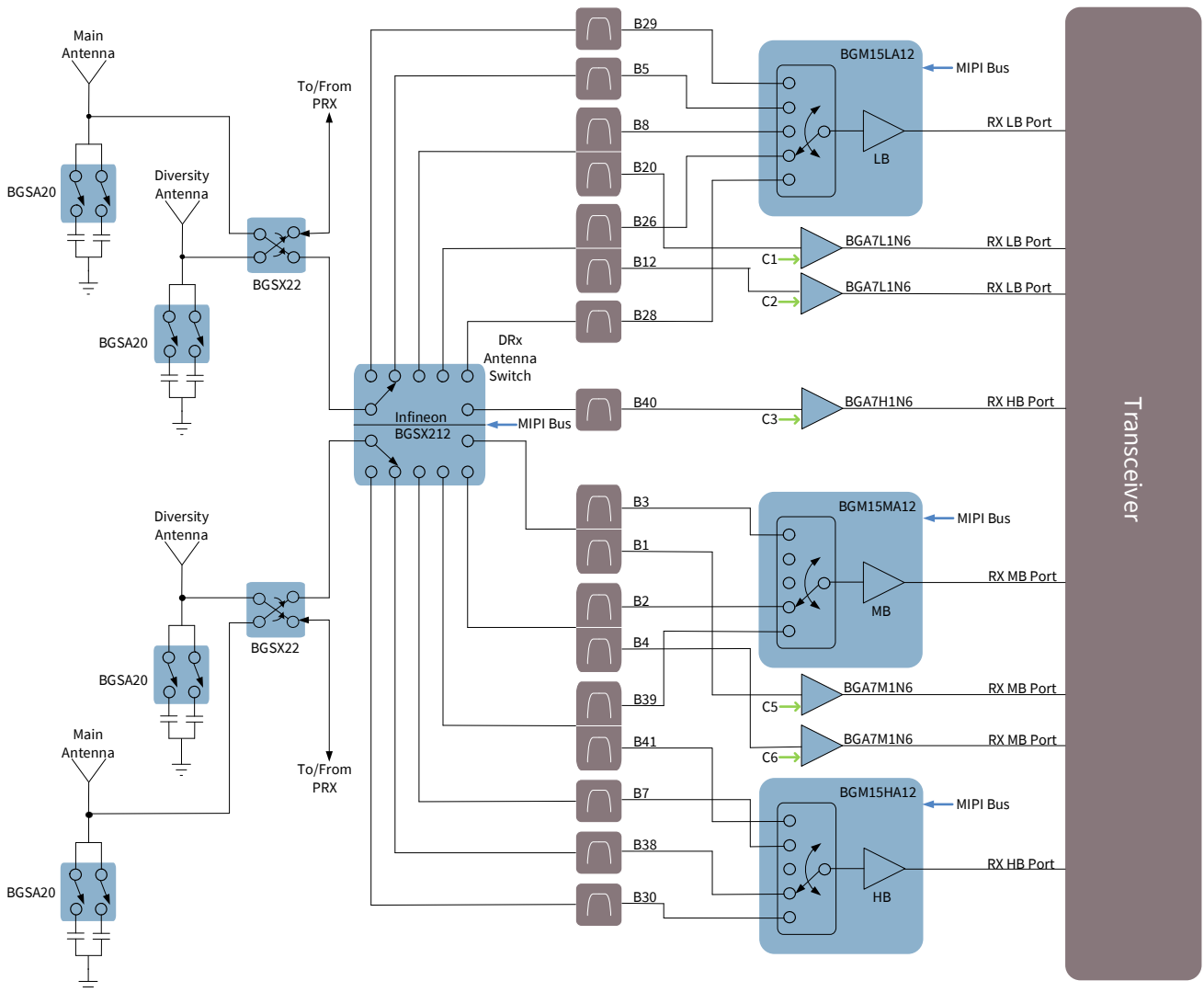

**Figure 6 RF FE architecture for Dual-antenna downlink up to 5 CA's**

### 2.3 Infineon's RF FE Supporting up to 2 Uplink CA Solutions:

For an RF FE supporting dual inter-band CA, two paths must operate simultaneously for each band. The simplest solution for dual inter-band CA is to duplicate the RF FE to transmit/receive each Component Carrier (CC) from different main antennas. However, this solution is costly. A more cost-effective solution is to adapt the RF FE to handle two inter-band carriers using the direct-mapping switch. The direct-mapping switch allows two RF FE paths to be activated separately or simultaneously so that the RF FE can be used in both CA and non-CA mode. The signals transmitted and received by the antenna can thus be combined or split and forwarded in different RF paths with the appropriate filters.

### 2.3.2 Infineon's Single-antenna RF FE CA Solution

In the below solution, dual-band in the 2 DL x 2 UL CA mode shares the same antenna, i.e. both bands use diplexers for CA.

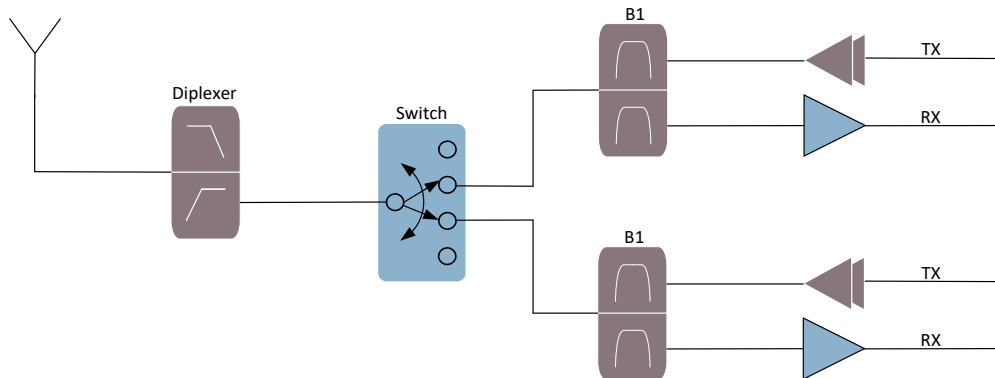

Figure 7 Block diagram of Inter-Band CA with single-antenna

### 2.3.3 Infineon's Dual-antenna RF FE CA Solution

Dual-band in the 4 DL x 2 UL CA mode uses separate antennas for each Transmission (Tx) path, i.e. for one antenna, one band uses a diplexer as the primary path, while the other with SAW filter is used as the secondary path, and vice versa.

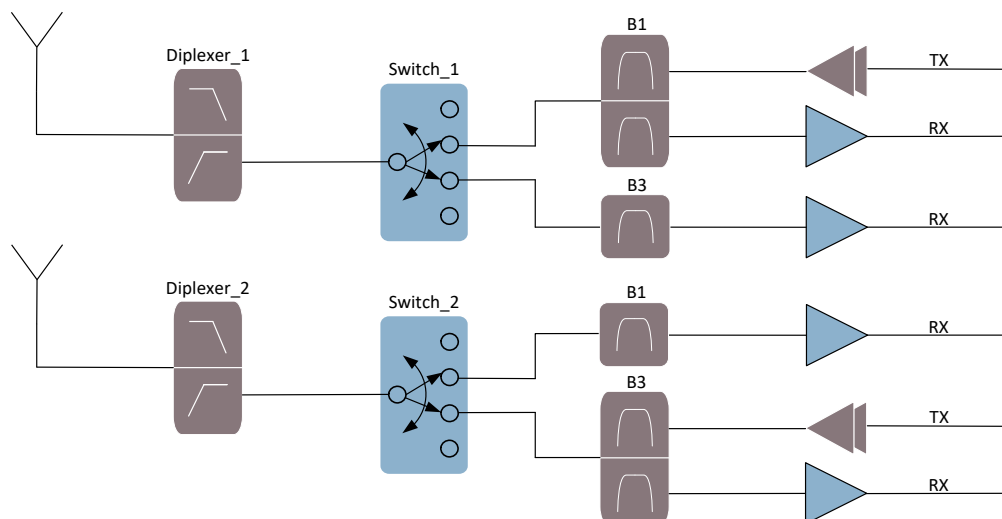
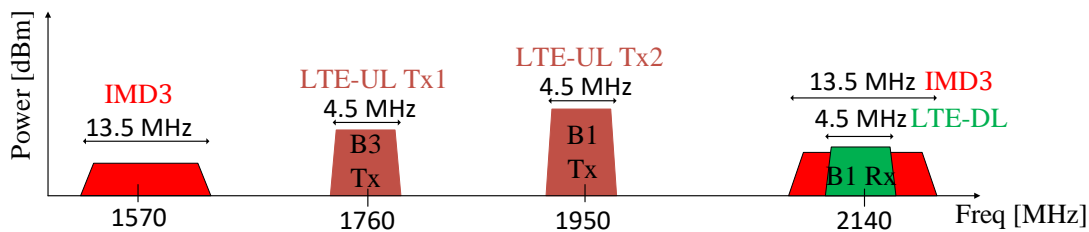

Figure 8 Block diagram of Inter-Band CA with dual-antenna

**LTE RF Receiver Intermodulation Analysis:** Due to the use of 2 or more bands simultaneously for uplink and downlink CA, unwanted Inter-Modulation Distortion (IMD) products are generated and make their way through one of the operating receive bands. As a result, it is important to study the effect of the RF FE components on the performance of the receiver.

At Infineon, we analyze the effect of the RF FE with the help of complex system-level simulation tools, and deduce the required linearity requirements while using the real LTE signals. Thus, unlike traditional IMD measurements with continuous wave tones, Infineon's approach is a more realistic when compared with the operating environment with fading and channel models. One such scenario of Band 1 and Band 3 CA is shown below.



**Figure 9 CA Band 1 and Band 3 IMD analysis using system-level simulation**

As an innovation partner, we encourage our customers to request various system simulations, and we are very willing to share our expertise to help improve RF architecture and implementation.

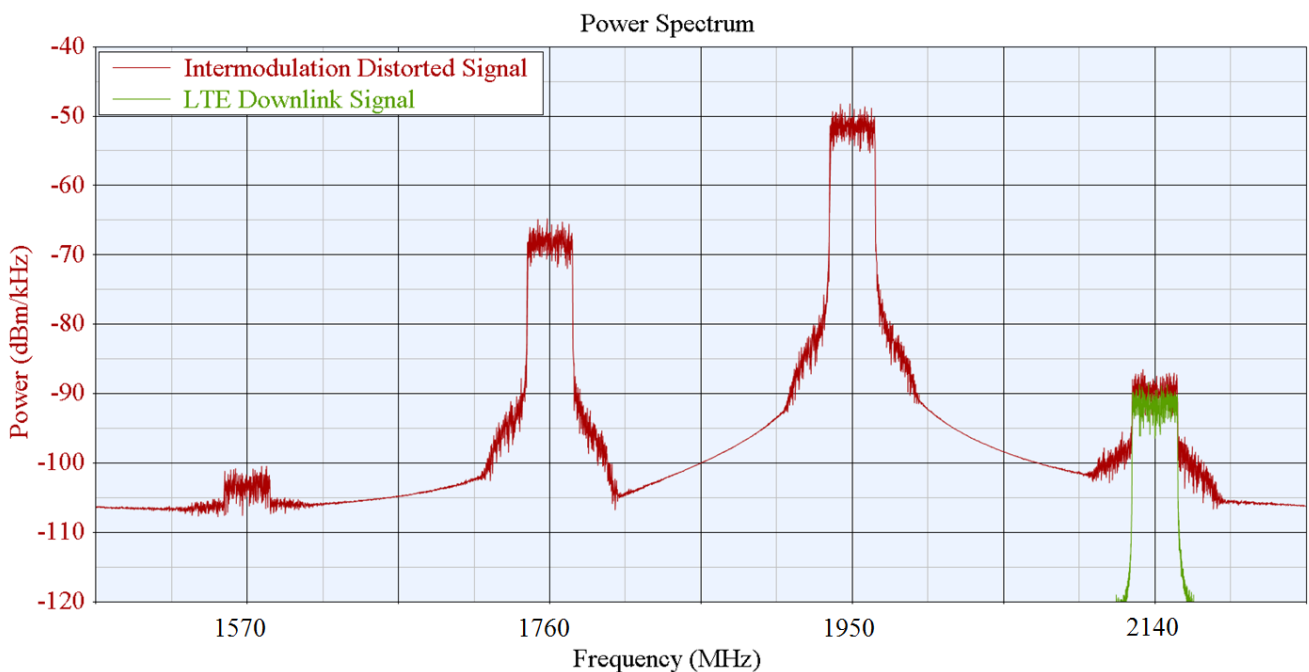

**Figure 10 CA Band 1 and Band 3 IMD analysis using system level simulation**

## **3 High and Medium-Power Switches for Mobile Phones and Wireless Systems**

Infineon's RF switches portfolio includes high-performance devices with low Insertion Loss (IL), high isolation and low harmonics generation. The RF switches are used for band selection and switching or diversity switching at the antenna or different RF paths within the RF (FE).

Infineon offers a wide variety of types from simple switches such as Single-Pole Double-Throw (SPDT) switches to complex high port count configurations, e.g. Single-Pole Ten-Throw (SP10T) or Double-Pole Fourteen-Throw (DP14T) switches. Their power capability ranges from medium power (+27 dBm) to high power (+39 dBm). The devices are manufactured using Infineon's patented MOS technology, offering the performance of GaAs devices with the economy and integration of conventional CMOS that has inherent higher ESD robustness.

Please visit our website [www.infineon.com/rfswitches](http://www.infineon.com/rfswitches) for more details on RF switches for mobile phone and all wireless applications, or contact your local Infineon or sales representative.

### **3.1 Key Challenges of Antenna Switches in Modern Mobile Applications**

Design of the RF FE in modern mobile phones becomes increasingly complex and demanding due to the increasing number of frequency bands and operation modes. One of the main components of an RF FE is the antenna switch that selects which Transmitter (TX)/Receiver (RX) path can be connected to the antenna. The RF switch has to satisfy high linearity requirements.

This section presents some of the main challenges of antenna switches in mobile applications.

#### ***Insertion Loss (IL)***

IL is an important parameter since the RF switch is placed between the antenna and the radio. Any increase of IL results in increased system noise in the receiver path and wastes transmit power, which reduces connectivity distance and battery life.

**Isolation (Iso)**

Isolation between ports is the measure of the signal suppression in excess of the IL between the “off” ports. High isolation in switches is desired to minimize the interference or leakage from other ports.

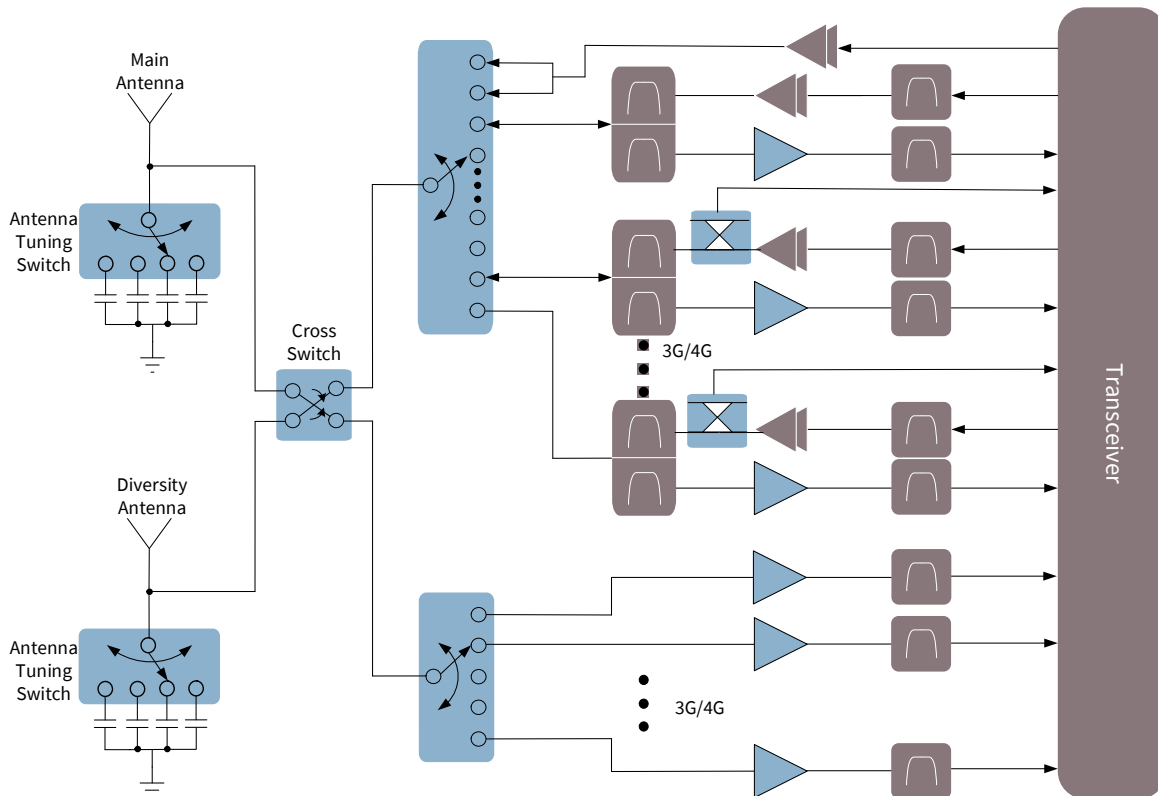

**Figure 11 Typical RF FE in a mobile phone**

**Compression Point (P1dB or P0.1dB)**

Compression Point is a measure of high power capability for RF FE switches. The P0.1dB specifies the input power level at the switch in dBm at which the IL of the switch increases by 0.1 dB compared to the value in the linear region with small signal operation. This value describes the power handling capability of the switch. Infineon’s switches are measured up to an input power of 30 to 40 dBm without observable deterioration in the IL.

**Harmonic Generation (2<sup>nd</sup> Harmonics H2 and 3<sup>rd</sup> Harmonics H3)**

Harmonic generation is an important parameter for the characterization of a RF switch. RF switches for mobile phones have to deal with high RF levels, up to 36 dBm, even with strongly mismatched conditions. Harmonics are generated with this high RF power at the input of the switch. These harmonics (e.g. 2<sup>nd</sup> and 3<sup>rd</sup>) can disturb other reception bands or cause interference in other RF functions e.g. Global Positioning System (GPS) or Wireless Local Area Network (WLAN) within the same mobile phone or in other nearby mobile phones.

### ***Inter-Modulation Distortion (IMD2 and IMD3)***

IMD is the linearity parameter of the device under multi-tone conditions. The intermodulation between each frequency component generates undesired outputs at the sum and difference frequencies of the input tones and at multiples of those sum and difference frequencies. The intermodulation products increase the spread of the signal spectrum which leads to adjacent channel interference.

### ***Digital Control Interface***

Traditionally, switches are controlled through the parallel General Purpose Input Output (GPIO) scheme, which involves a set of parallel control lines with pre-defined “high” and “low” logic. This is mainly used for all low-complexity RF switches. Mobile chipset companies formed the Mobile Industry Processor Interface (MIPI) alliance, aiming to standardize communication between all major components in mobile devices with structured register commands. All companies in this alliance are adopting MIPI and requiring RF switches used in their mobile devices to be MIPI-compatible.

## **3.1.1 Mobile Industry Processor Interface (MIPI) for Mobile Phones**

The MIPI contains 20 standardized interfaces for mobile phone device platforms. Some examples include:

- **RFFE**, a two-wire serial bus for control of **RF Front-End** components, e.g. LNAs or RF-Switches
- **SoundWire**, a two-wire time-division bus supporting multiple clocks, and audio clocks for audio broadcast, e.g. microphones or speaker.
- **SensWire** (Sensor IF), a 2-pin interface that is backwards compatible with I2C standards and is comparable to SPI for sensors, e.g. pressure sensors.

An overview of MIPI interfaces on a mobile phone platform is shown in Figure 12.

## **3.1.2 MIPI RF FE for RF Front-End Devices in Mobile Phones**

MIPI RFFE is the common control interface for the high complexity Mobile Phone RF FE systems. It is a flexible two-wire serial bus, designed primarily for control of RF FE components, that allows for very simple to complex slave devices. One bus master can write and read up to 15 devices, such as power amplifiers, sensors, switch modules, and antenna tuners. RF FE includes a group trigger function for timing-critical events and provisions for low current consumption and low EMI. The MIPI RF FE interface is used to reduce control line complexity and RF IC pin count.

The MIPI RF FE Bus can support a speed of 52 MHz. The VIO pin supports 1.2 V and/or 1.8 V. The bus protocol is a single-ended signaling for a clock line, along with a bi-directional data line, in a point-to-multipoint configuration. The figure 12 shows a MIPI RF FE with one Master (RFIC) and up to 15 Slaves such as LNAs, switches or antenna tuning switches.

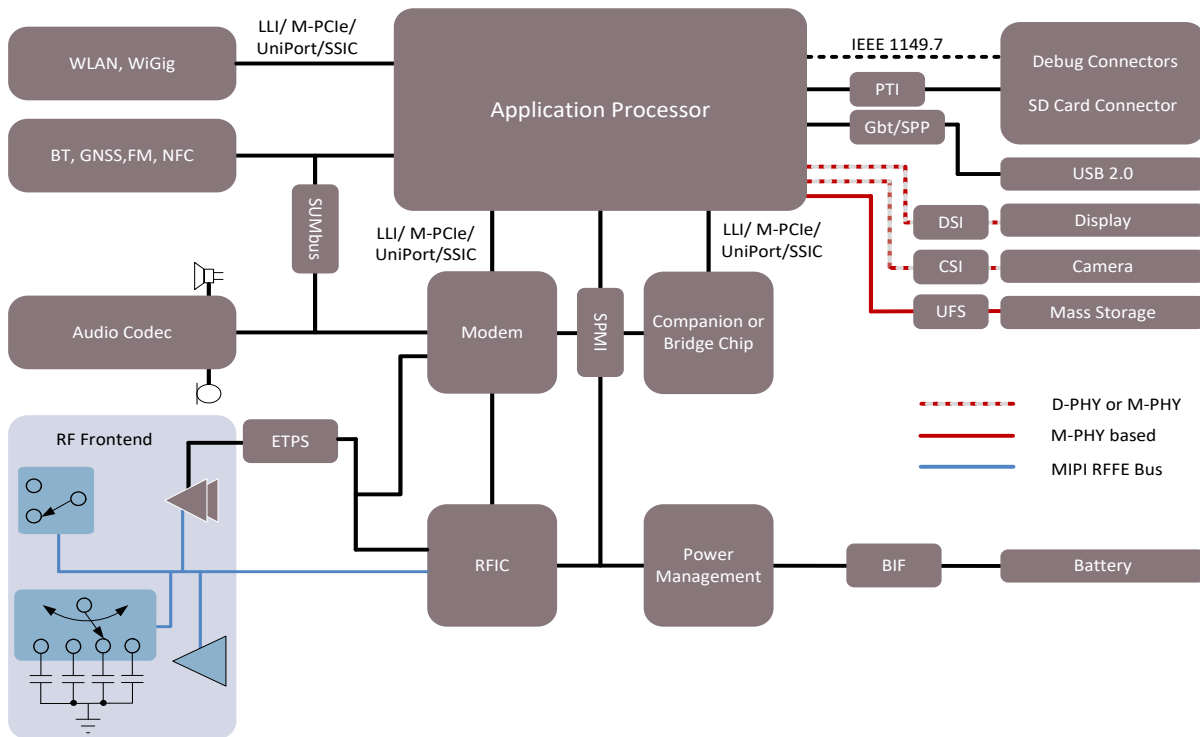

**Figure 12 Overview of MIPI interfaces on a mobile phone platform**

A typical MIPI bus structure is shown in Figure 13.

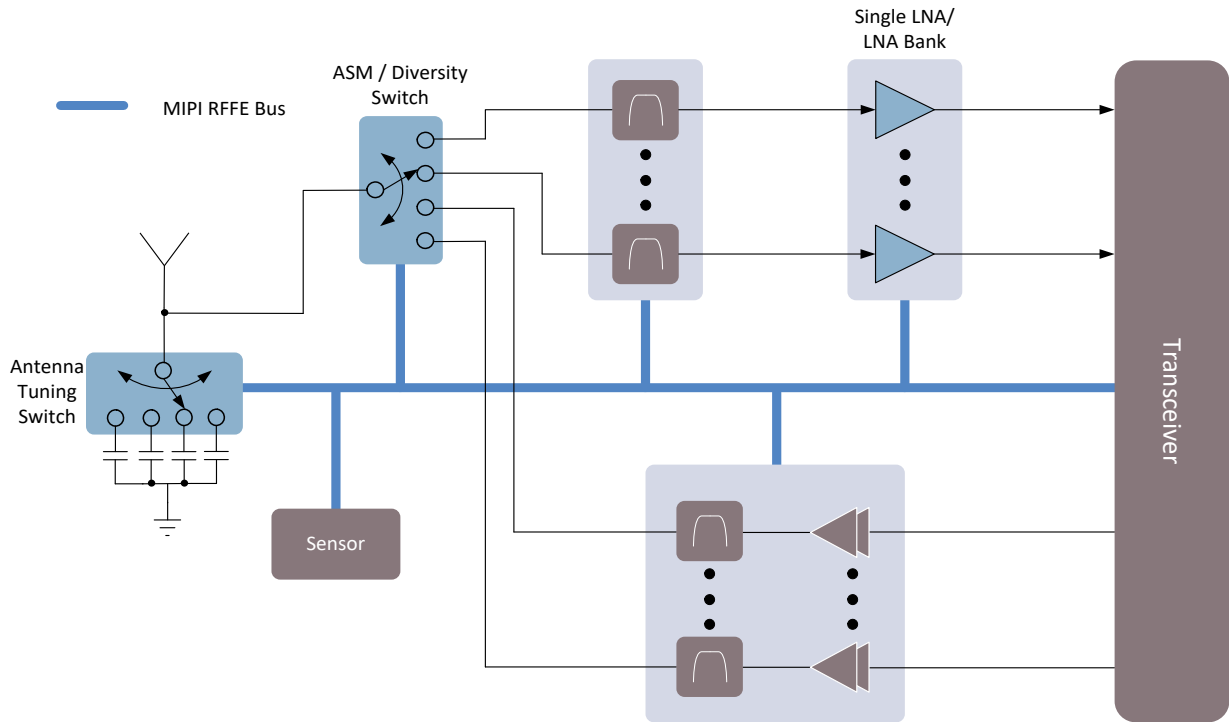
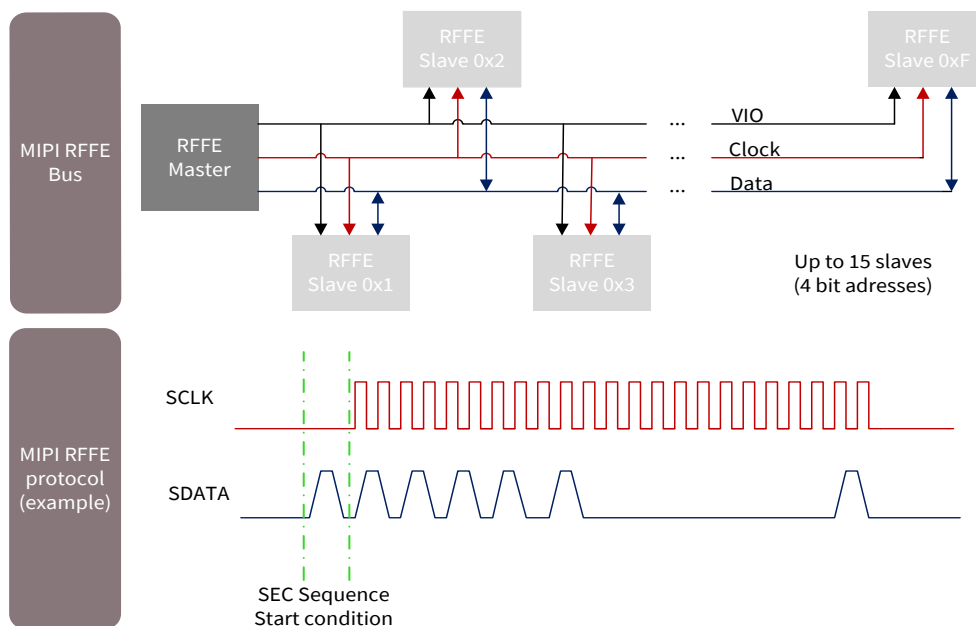

**Figure 13 Typical MIPI RFFE bus in a mobile phone**

### 3.1.3 Specification V2.10 of MIPI Alliance

The MIPI RFFE specification defines the basic functionality of the RFFE bus but it also provides the freedom to specify additional registers, customer related features and default values.

Please refer to MIPI Alliance for more details about the latest MIPI interface standards: <http://www.mipi.org>



**Figure 14 Example of MIPI RFFE interfaces in a mobile phone**

### 3.2 High- and Medium-Power RF Switches

#### 3.2.1 Ultra-High Linearity Switches

The high power handling capability, outstanding linearity, and excellent insertion loss and isolation performance enable below types to meet the stringent linearity requirements of mobile devices and data-card switching applications. The BGS14MPA9 with MIPI RFFE Interface supports 5G applications.

##### Ultra-High Linearity / High Power Switches

Product	Type	App. Note	V <sub>dd</sub> [V]	V <sub>ctrl</sub> <sup>1)</sup> [V]	IL <sup>2)</sup> [dB]	Iso. <sup>3)</sup> [dB]	P <sub>in,max</sub> <sup>4)</sup> [dBm]	Ctrl. Int. <sup>5)</sup>	Package
<a href="#">BGS12PL6</a>	SPDT	<a href="#">AN319</a>	2.4...3.6	1.4 - V <sub>dd</sub>	0.36 / 0.46	37 / 27	+36	GPIO	TSLP-6
<a href="#">BGS12PN10</a>	SPDT	<a href="#">AN497</a>	1.8 - 3.6	1.2...2.85	0.2/0.25	38 / 30	+40	GPIO	TSNP-10
<a href="#">BGS13PN10</a>	SP3T	on request	1.8 - 3.6	1.2...2.85	0.2/0.25	35 / 28	+40	GPIO	TSNP-10
<a href="#">BGS14PN10</a>	SP4T	<a href="#">AN498</a>	1.8 - 3.6	1.2...2.85	0.2/0.3	40/30	+40	GPIO	TSNP-10
<a href="#">BGS14MPA9</a>	SP4T	on request	1.65...1.95	RFFE MIPI	0.2/0.25	50/40	+38	RFFE MIPI	ATSLP-9

Notes: 1) Digital Control Voltage (logic high); 2) IL = Insertion Loss at 1.0/2.0 GHz; 3) Isolation at 1.0/ 2.0 GHz from RF<sub>in</sub> to RF port; 4) Maximum input power; 5) Control Interface; 6) Please visit [www.infineon.com/rfswitches](http://www.infineon.com/rfswitches) for alternative devices.

NEW!

#### 3.2.2 Diversity Antenna Switches

The recent trend of mobile device users to download data at a higher rate requires a higher bandwidth and an additional receiver channel called the diversity path. To select the right receive band, one option is to use a diversity switch with low insertion loss and excellent RF performance. Diversity switches covering more than 10 different UMTS/LTE bands are becoming more and more popular in smartphones and tablets.

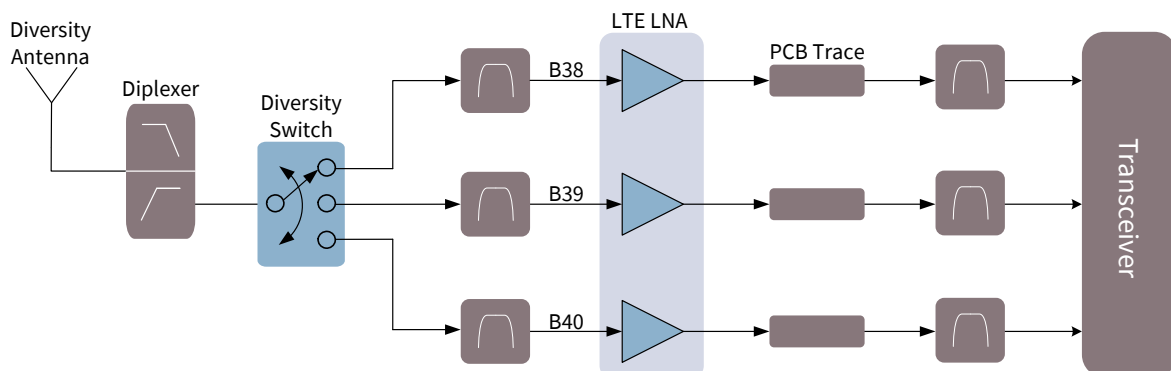

Figure 15 Example of TD-LTE band for diversity path

# Application Guide for Mobile Communication

## High and Medium-Power Switches for Mobile Phones and Wireless Systems



### RF CMOS Switches for Diversity Antenna

Product	Type	App. Note	V <sub>dd</sub> [V]	V <sub>ctrl</sub> <sup>1)</sup> [V]	IL <sup>2)</sup> [dB]	Isolation <sup>3)</sup> [dB]	P <sub>in,max</sub> <sup>4)</sup> [dBm]	Ctrl. <sup>5)</sup> Int.	Package
<a href="#">BGS12SN6</a>	SPDT	<a href="#">AN332</a>	1.8...3.5	1.35...V <sub>dd</sub>	0.25 / 0.28	40 / 32	30	GPIO	TSNP-6
<a href="#">BGS13GA14</a>	SP3T	<a href="#">AN478</a>	2.4...3.4	1.35...V <sub>dd</sub>	0.3/0.4	45/40	32	GPIO	<a href="#">ATSLP-14</a>
<a href="#">BGS13S3N9</a>	SP3T	on request	1.8...3.3	1.35...V <sub>dd</sub>	0.25/0.4	44/29	32	GPIO	<a href="#">TSNP-9</a>
<a href="#">BGS13S4N9</a>	SP3T	on request	1.8...3.3	1.35...V <sub>dd</sub>	0.25/0.4	44/29	32	GPIO	<a href="#">TSNP-9</a>
<a href="#">BGS14GA14</a>	SP4T	<a href="#">AN479</a>	2.4...3.4	1.35...V <sub>dd</sub>	0.3/0.4	45/40	32	GPIO	<a href="#">ATSLP-14</a>
<b>NEW!</b> <a href="#">BGS14MA11</a>	SP4T	on request	1.7...3.4	RFFE MIPI	0.2/0.25	40/32	35	RFFE MIPI	<a href="#">ATSLP-11</a>
<a href="#">BGS15GA14</a>	SP5T	<a href="#">AN480</a>	2.4...3.4	1.35...V <sub>dd</sub>	0.3/0.4	45/40	32	GPIO	<a href="#">ATSLP-14</a>
<a href="#">BGS16GA14</a>	SP6T	<a href="#">AN481</a>	2.4...3.4	1.35...V <sub>dd</sub>	0.23/0.43	50/39	32	GPIO	<a href="#">ATSLP-14</a>
<b>NEW!</b> <a href="#">BGS16MA12</a>	SP6T	on request	1.65...1.95	RFFE MIPI	0.3/0.4	40/30	35	RFFE MIPI	<a href="#">ATSLP-12</a>
<a href="#">BGS17GA14</a>	SP7T	<a href="#">AN482</a>	2.4...3.4	1.35...V <sub>dd</sub>	0.27/0.48	50/39	32	GPIO	<a href="#">ATSLP-14</a>
<b>NEW!</b> <a href="#">BGS18MA12</a>	SP8T	on request	1.65...1.95	RFFE MIPI	0.3/0.45	40/30	35	RFFE MIPI	<a href="#">ATSLP-12</a>
<a href="#">BGS18MA14</a>	SP8T	on request	1.7...3.4	RFFE MIPI	0.3/0.4	45/35	35	RFFE MIPI	<a href="#">ATSLP-14</a>
<a href="#">BGS18GA14</a>	SP8T	<a href="#">AN483</a>	2.4...3.4	1.35...V <sub>dd</sub>	0.27/0.48	50/39	32	GPIO	<a href="#">ATSLP-14</a>
<a href="#">BGS110MN20</a>	SP10T	on request	2.5...5.5	RFFE MIPI	0.4	37	32	RFFE MIPI	TSNP-20

Notes: 1) Digital Control Voltage (logic high); 2) IL = Insertion Loss at 1.0/2.0 GHz; 3) Isolation at 1.0/2.0 GHz from RF<sub>in</sub> to RF port; 4) Maximum input power; 5) Control Interface; 6) Please visit [www.infineon.com/rfswitches](http://www.infineon.com/rfswitches) for alternative devices.

### Carrier-Aggregation-Capable RF CMOS Switches for Diversity Antenna

Product	Type	App. Note	V <sub>dd</sub> [V]	V <sub>ctrl</sub> <sup>1)</sup> [V]	IL <sup>2)</sup> [dB]	Isolation <sup>3)</sup> [dB]	P <sub>in,max</sub> <sup>4)</sup> [dBm]	Ctrl. <sup>5)</sup> Int.	Package
<a href="#">BGS15MA12</a>	SP5T	on request	2.2...5.5	MIPI interface	0.28 / 0.35	34 / 27	27	RFFE MIPI	ATSLP-12
<b>NEW!</b> <a href="#">BGSX44MA12</a>	4P4XT	on request	1.65...1.95	RFFE MIPI	0.45/0.6	46/40	28	RFFE MIPI	<a href="#">ATSLP-12</a>
<a href="#">BGSx28MA18</a>	DP8T	on request	2.5...3.4	RFFE MIPI	0.25/0.5	48/39	32	RFFE MIPI	ATSLP-18
<a href="#">BGSx210MA18</a>	DP10T	on request	2.5...3.4	RFFE MIPI	0.25/0.5	48/39	32	RFFE MIPI	ATSLP-18
<a href="#">BGSx212MA18</a>	DP12T	on request	2.5...3.4	MIPI interface	0.25/0.5	48/39	32	RFFE MIPI	ATSLP-18

Notes: 1) Digital Control Voltage (logic high); 2) IL = Insertion Loss at 1.0/2.0 GHz; 3) Isolation at 1.0/2.0 GHz from RF<sub>in</sub> to RF port; 4) Maximum input power; 5) Control Interface; 6) Please visit [www.infineon.com/rfswitches](http://www.infineon.com/rfswitches) for alternative devices.

### 3.2.3 Band-selection Switches in a Single-ended Configuration

The number of LTE bands that a mobile phone has to support is increasing rapidly. The following two examples show band selection with an SPDT switch in a single-ended configuration.

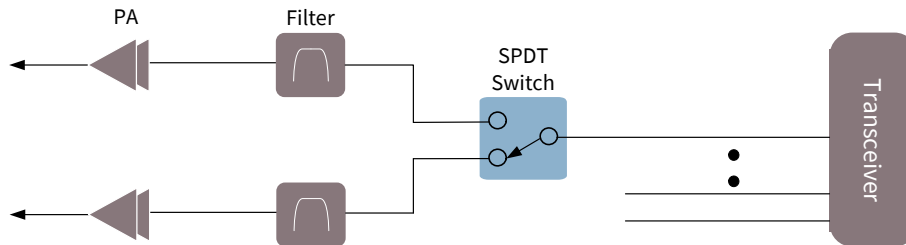

Figure 16 Band switching with CMOS SPDT switch

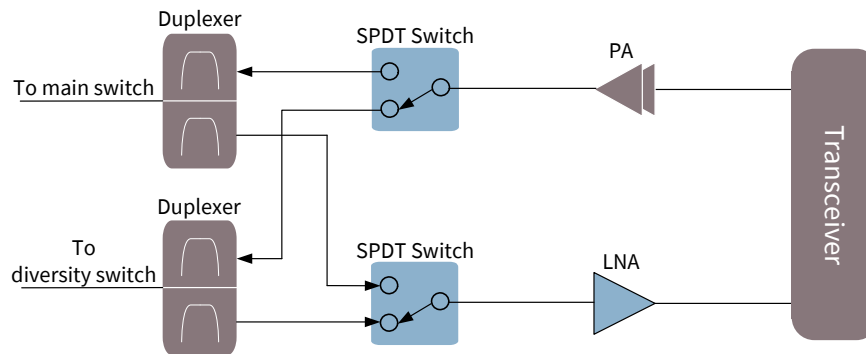

Figure 17 LTE Band-1/Band-4 switching with CMOS SPDT switch

#### RF CMOS Switches

Product	Type	App. Note	V <sub>dd</sub> [V]	V <sub>ctrl</sub> <sup>1)</sup> [V]	IL <sup>2)</sup> [dB]	Isolation <sup>3)</sup> [dB]	P <sub>in,max</sub> <sup>4)</sup> [dBm]	Ctrl. Int. <sup>5)</sup>	Package
<a href="#">BGS12PL6</a>	SPDT	<a href="#">AN319</a>	2.4...3.6	1.4 - V <sub>dd</sub>	0.36 / 0.46	37 / 27	36	GPIO	TSLP-6-4
<a href="#">BGS12SN6</a>	SPDT	<a href="#">AN332</a>	1.8...3.3	1.35...V <sub>dd</sub>	0.25 / 0.28	40 / 28	30	GPIO	TSNP-6-2
<a href="#">BGS13GA14</a>	SP3T	<a href="#">AN478</a>	2.4...3.6	1.35...V <sub>dd</sub>	0.4/0.45	45/40	32	GPIO	ATSLP-14
<a href="#">BGS13S4N9</a>	SP3T	on request	1.8...3.3	1.35...V <sub>dd</sub>	0.25/0.4	44/29	32	GPIO	TSNP-9-3
<a href="#">BGS14GA14</a>	SP4T	<a href="#">AN479</a>	2.4...3.4	1.35...V <sub>dd</sub>	0.3/0.4	45/40	32	GPIO	ATSLP-14
<a href="#">BGS14MA11</a>	SP4T	on request	1.7...3.4	RFFE MIPI	0.2/0.25	40/32	35	RFFE MIPI	<a href="#">ATSLP-11</a>
<a href="#">BGS14MPA9</a>	SP4T	on request	1.65...1.95	RFFE MIPI	0.2/0.25	50/40	38	RFFE MIPI	ATSLP-9

Notes: 1) Digital Control Voltage (logic high); 2) IL = Insertion Loss at 1.0/ 2.0 GHz; 3) Isolation at 1.0/ 2.0 GHz from RF<sub>in</sub> to RF port; 4) Maximum input power; 5) Control Interface; 6) Please visit [www.infineon.com/rfswitches](http://www.infineon.com/rfswitches) for alternative devices.

NEW!  
 NEW!

### 3.2.4 Cross Switches

The Figure 18 shows a typical application for a cross switch in a mobile phone. This device allows a designer to select the best performing antenna for optimizing transmit power for an Up-Link (UL) or improved receive sensitivity for a Down-Link (DL).

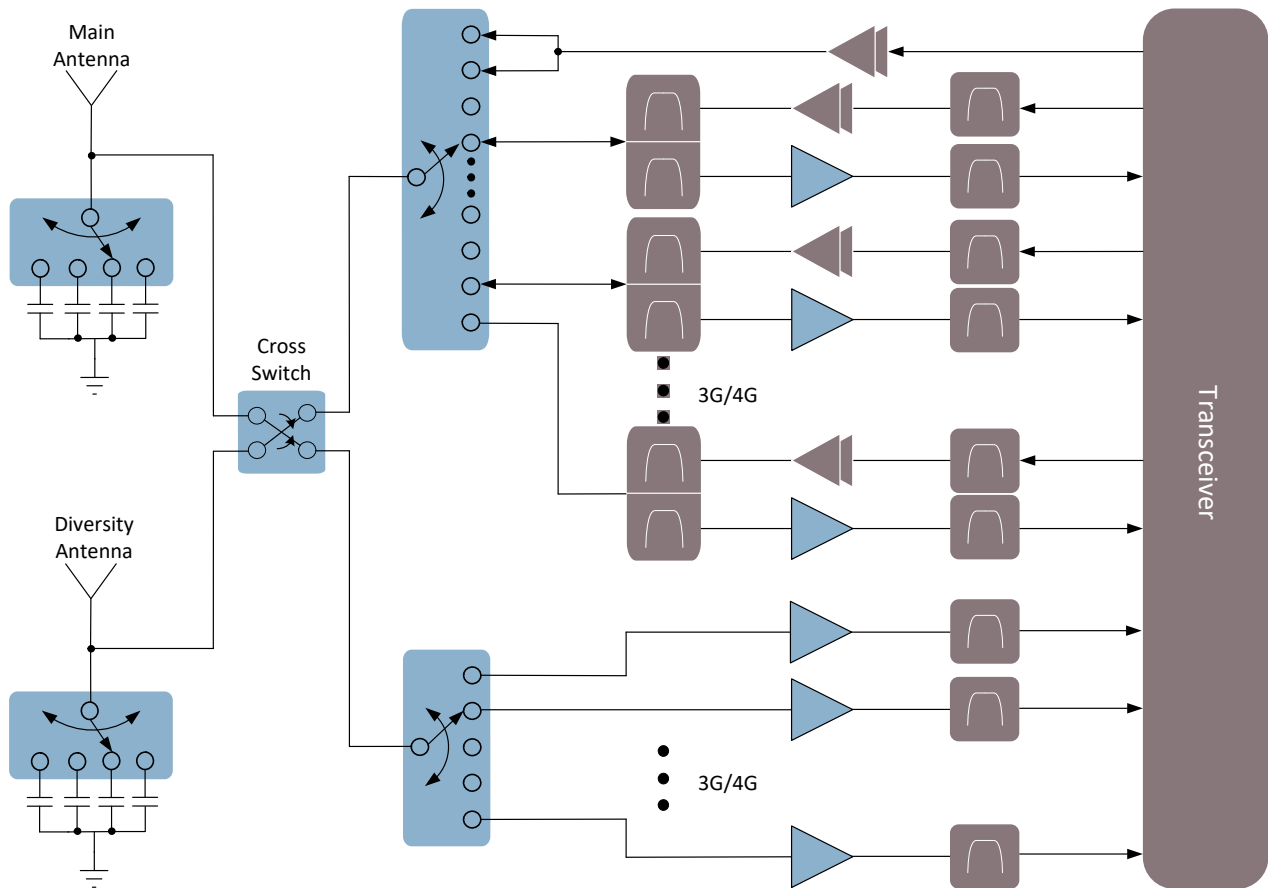

Figure 18 An example of cross switch application

#### Cross Switches for Antenna Selection

Product	Type	App. Note	Supply $V_{DD}$ [V]	$V_{ctrl}^{1)}$ [V]	$IL^{2)}$ [dB]	Isolation <sup>3)</sup> [dB]	$P_{in,max}^{5)}$ [dBm]	Ctrl. Int. <sup>6)</sup>	Package
<a href="#">BGSX22GN10</a>	DPDXT	on request	1.8 – 3.3	1.35... $V_{DD}$	0.35 / 0.5	25 / 22	36	GPIO	TSNP-10
<a href="#">BGSX 22G5A10</a>	DPDXT	on request	1.65...3.4	1.35... $V_{DD}$	0.3/0.4	58/52	39	GPIO	ATSLP-10
<a href="#">BGSX 33MA16</a>	3P3XT	on request	1.65...3.4	RFFE MIPI	0.35/0.5	51/46	38.5	RFFE MIPI	ATSLP-16

Notes: 1) Digital Control Voltage (logic high); 2)  $IL$  = Insertion Loss at 1.0/ 2.0 GHz; 3) Isolation at 1.0/ 2.0 GHz; 4) 0.1 dB compression point; 5) Maximum input power; 6) Control Interface; 7) Please contact your local Infineon or sales representatives for further products.

NEW!

NEW!

### 3.3 Antenna Tuning Switches

With the requirement for higher data transfer rates in mobile communications, the need for wider bandwidth is ever increasing. To meet this need, more and more frequency bands are being defined by the 3<sup>rd</sup> Generation Partnership Project (3GPP) consortium. The LTE-A standard specifies more than 60 LTE frequency bands that can be used to transmit mobile signals. Consequently, a mobile phone antenna should be able to perform well in several frequency bands. Hence there is a growing need to tune antennas according to the selected frequency bands.

In addition, antenna tuning improves antenna radiation efficiency as well as the Total Radiated Power (TRP). This reduces the stress on the antenna driving hardware on the transmitter side, and increases sensitivity on the receiver side. Antenna tuning devices based on Infineon's CMOS switch technology in mobile phones allow the use of smaller antennas and/or broader frequency range. There are two types of antenna tuning: antenna impedance matching and antenna aperture tuning.

#### 3.3.1 Antenna Impedance Matching

Antenna impedance matching is carried out at the antenna feed point as shown in Figure 19. Using this type of antenna tuning, forward power to the antenna can be optimized by matching the antenna input impedance to 50 ohms. This improves antenna performance by optimizing forward power to the antenna, but has no effect on the antenna's (resonant frequency or radiation efficiency). Hence this type of antenna tuning is generally not preferred.

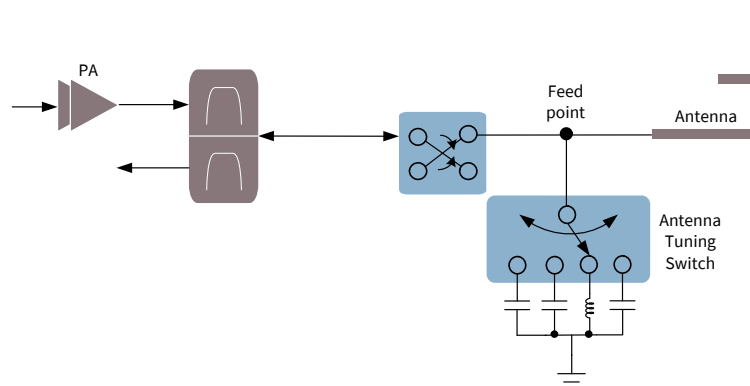

**Figure 19 Antenna impedance matching**

### 3.3.2 Antenna Aperture Tuning

A more widely used antenna tuning technique is antenna aperture tuning which effectively changes the characteristics of the antenna and significantly improves its radiation efficiency and Total Radiated Power (TRP). Hence this kind of antenna tuning is key focus of Infineon as shown in Figure 20.

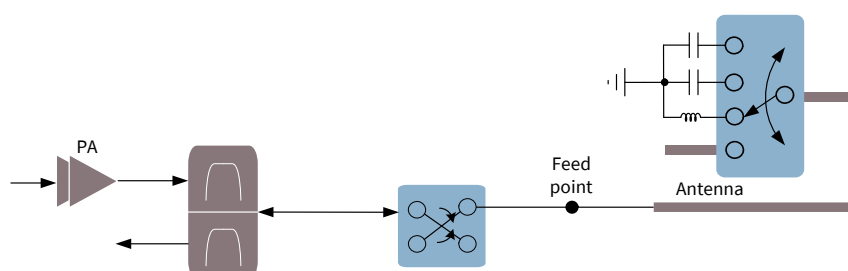

**Figure 20 Antenna aperture tuning**

### 3.3.3 System Approach to Aperture Tuning

Infineon provides complete antenna-tuning solutions for our customers, using our antenna-tuning switches. There are two approaches that are used for antenna tuning. The more common approach is to use antenna S-parameters. Another more recently introduced approach uses antenna dimensions to tune the antenna. These approaches are explained in detail in the following sections. There are two ports on a standard mobile phone Planar Inverted F antenna (PIFA), namely the *Feed port* and the *Tuning port* as shown in Figure 21. The antenna-tuning switch with matching elements (capacitor/inductor) is placed on the tuning port of the antenna.

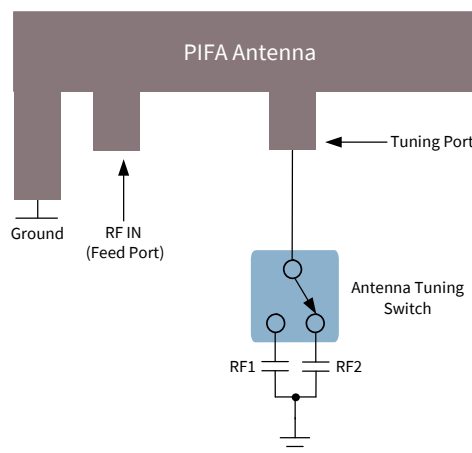

**Figure 21 System diagram for antenna aperture tuning**

**Aperture tuning using antenna S-parameters**

In this approach, the two port antenna S-parameters are used to tune the PIFA antenna. The S-parameters are measured and then imported into the circuit simulator. Using these S-parameters, the tuning circuit is created as shown in Figure 22.

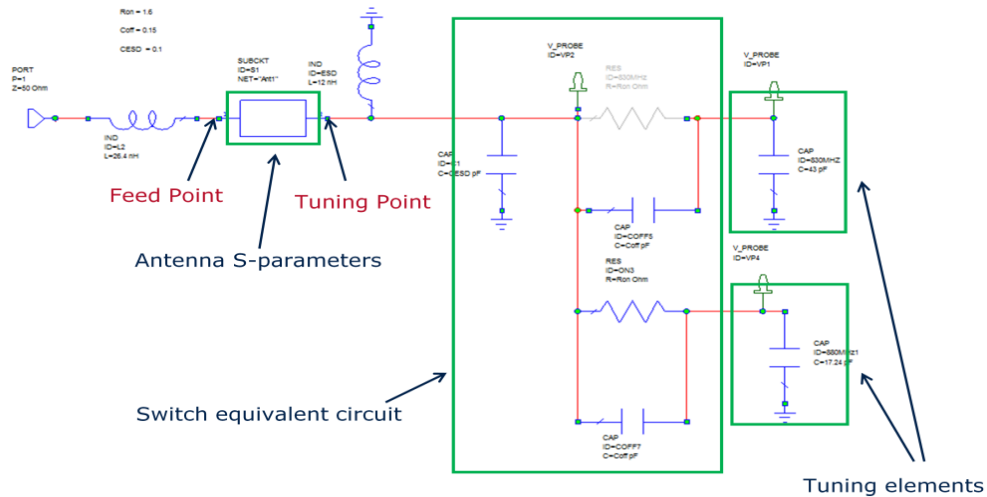

**Figure 22 Circuit diagram for aperture tuning**

**Aperture tuning using antenna dimensions**

In this approach the customer provides the antenna dimensions. The antenna layout is created and simulated using a 3-dimensional (3D) Electro-Magnetic (EM) simulator. S-parameters are then extracted and the antenna-tuning circuit is created using the same approach that was described in Section 3.3.3. The only major difference between this approach and the previous approach is that here, the antenna S-parameters are extracted from the EM simulations and circuit elements are co-simulated with the EM simulation as shown in Figure 23.

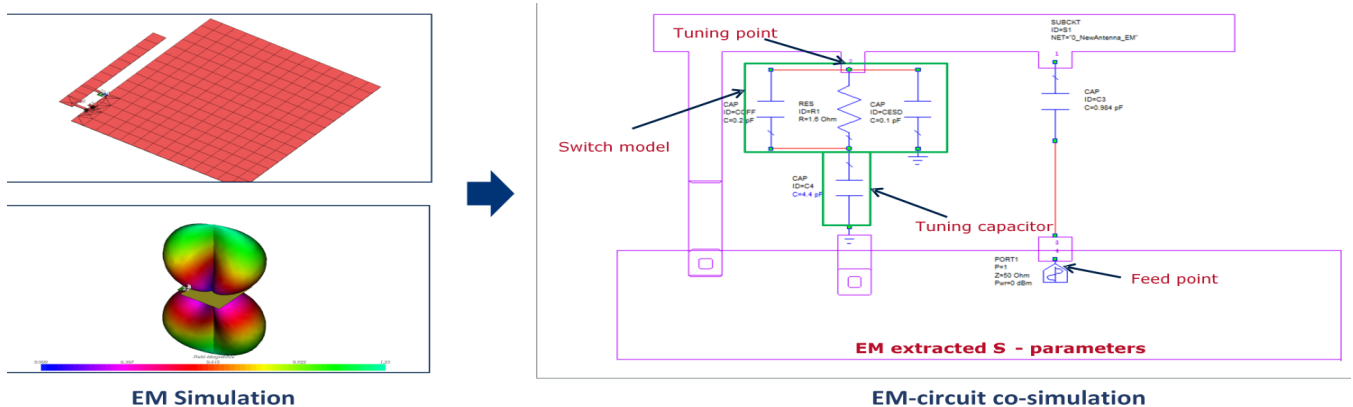

**Figure 23 EM Simulation**

### 3.3.4 Key Parameters of Antenna Tuning Switches

Since antenna-tuning switches are modified versions of standard switches, the basic design challenges of standard switches apply to antenna-tuning switches as well. In addition there are some special characteristics that are important for mobile phone antenna tuning. These are explained in this section.

#### On Resistance ( $R_{on}$ )

The  $R_{on}$  of an antenna-tuning switch is one of its main differentiating features. The lower the  $R_{on}$  is, the better the switch performs. As an antenna-tuning switch is directly connected to the antenna, higher  $R_{on}$  means higher loss and lower quality factor (Q-factor). Infineon’s antenna-tuning switches have very low  $R_{on}$ , ranging from 0.4 ohm to 4.5 ohm in each RF port.  $R_{on}$  has different effect on different types of antenna tuning. For high voltage antenna tuning,  $R_{on}$  has a negligible effect, but for low voltage tuning,  $R_{on}$  has a huge effect. This phenomenon is explained in Figure 24 and Figure 25.

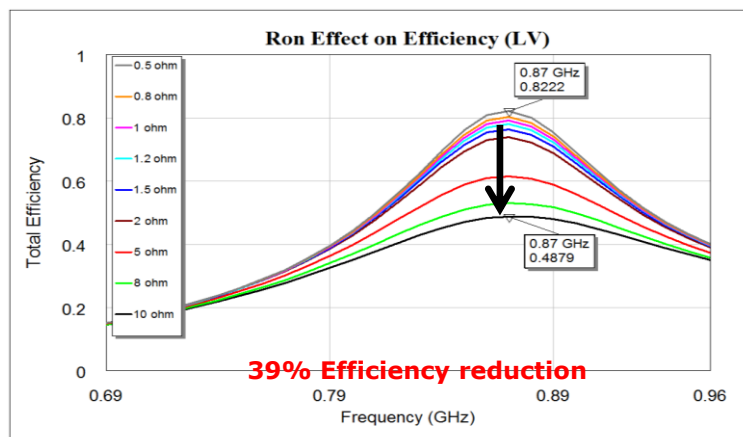

Figure 24 Low voltage tuning case

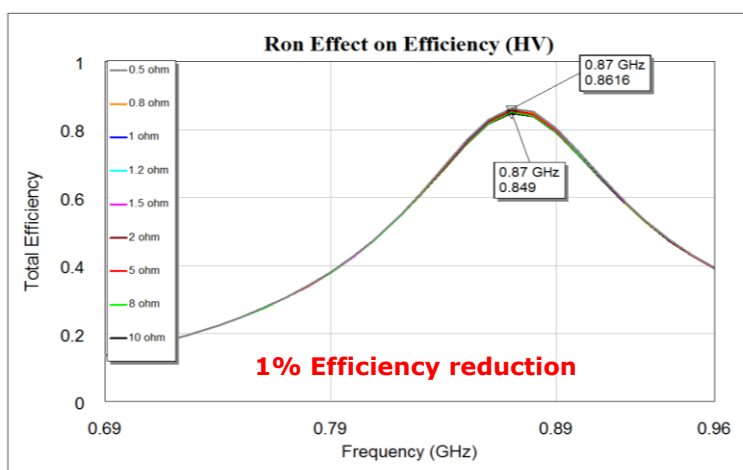
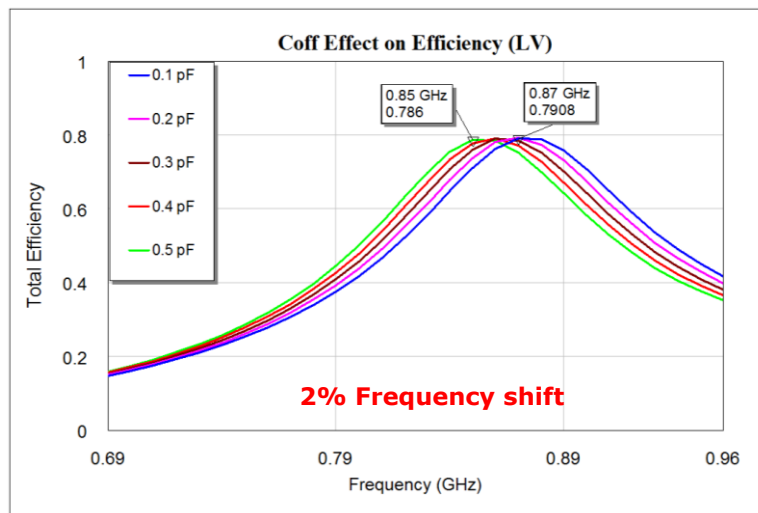

Figure 25 High voltage tuning case

**Off Capacitance ( $C_{OFF}$ )**

$C_{OFF}$  is also one of the key features of an antenna-tuning switch. A higher  $C_{OFF}$  results in a large high-frequency band loss and also causes self-resonances. Thus for better performance, a lower  $C_{OFF}$  is important for an antenna-tuning switch. Infineon’s antenna tuning switches have a very low  $C_{OFF}$ , in the range of 120 femtofarad – 250 femtofarad.

$C_{OFF}$  also has different effects on different kinds of antenna tuning. For high voltage aperture tuning,  $C_{OFF}$  has a huge de-tuning effect on the antenna; for low voltage aperture tuning, this effect is quite small. This phenomenon is shown in Figure 26 and Figure 27.



**Figure 26 Low voltage tuning case**

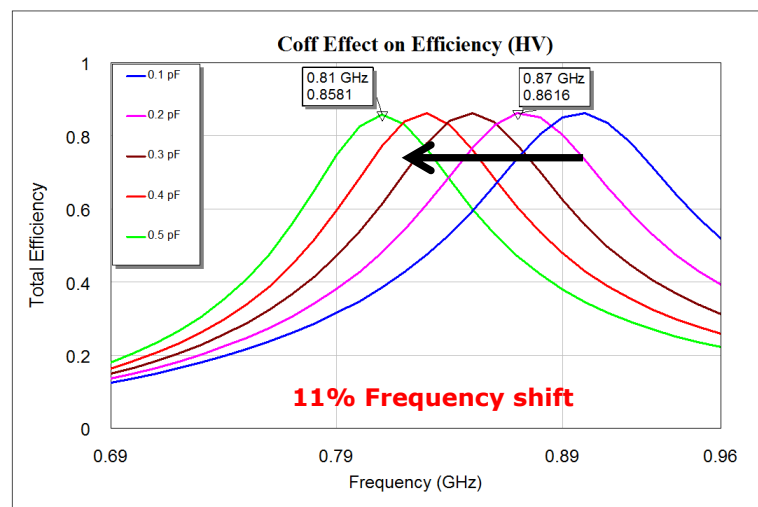

**Figure 27 High voltage tuning case**

### Maximum RF Voltage ( $V_{RF}$ )

Depending on the antenna design, the impedance of the antenna varies with frequency. High impedance of the antenna results in a high  $V_{RF}$  across the antenna-tuning switch. Generally, the voltage generated is much higher than the specified  $V_{RF}$  for a standard switch. Hence Infineon's antenna-tuning switches have higher  $V_{RF}$  handling capacity to meet the special requirements for antenna tuning. Infineon's antenna-tuning switches are therefore rated up to 44 V for low voltage switches and up to 80 V for high voltage switches.

### RF CMOS Switches for Antenna Tuning

Product	Type	App. Note	Supply [V]	$V_{ctrl}^{1)}$ [V]	$IL^{2)}$ [dB]	Isolation <sup>3)</sup> [dB]	$R_{on}^{4)}$ [ $\Omega$ ]	$C_{off}^{5)}$ [fF]	$V_{RFmax}^{6)}$ [V]	Package
<a href="#">BGSA11GN10</a>	Dual SPST	on request	1.8...3.6	0...2.85	0.16/0.25	23/17	0.79	250	36	TSNP10-1
<a href="#">BGSA12GN10</a>	SPDT	on request	1.8...3.6	0...2.85	0.25/0.32	30/23	1.6	120	36	TSNP10-1
<a href="#">BGSA13GN10</a>	SP3T	on request	1.8...3.6	0...2.85	0.2..0.8/ 0.29 ..0.44	26/20	0.8/1.4/1.6	300/160/ 120	36	TSNP10-1
<a href="#">BGSA131MN10</a>	SP3T	on request	1.8...3.6	0...2.85	0.2/0.6	12/20	0.5/1/1	600/300/ 300	44	TSNP10-1
<a href="#">BGSA132MN10</a>	SP3T	on request	1.8...3.6	0...2.85	0.2/0.6	12/20	0.5/1/1	600/300/ 300	44	TSNP10-1
<a href="#">BGSA133GN10</a>	SP3T	on request	1.8...3.6	0...2.85	0.2/0.6	12/20	0.5/1/1	600/300/ 300	44	TSNP10-1
<a href="#">BGSA14GN10</a>	SP4T	on request	1.8...3.6	0...2.85	0.26/0.37	31/25	1.6	120	36	TSNP10-1
<a href="#">BGSA20GN107</a>	2x SPST	on request	1.8...3.6	0...2.85	--	35/44	4.5	250	80	TSNP10-1
<a href="#">BGSA14RN10</a>	SP4T	on request	1.8...3.6	0...2.85	0.25/0.8	16/25	0.95	300	44	TSNP10-1
<b>NEW!</b> <a href="#">BGSA12UGL8</a>	SPDT	on request	1.8...3.6	0...2.85	0.14/0.39	24/15	0.59	270	40	TSLP-8-1
<a href="#">BGSA141MN10</a>	SP4T	on request	2.3...3.6	0...1.95	0.25/0.65	25/17	1.0	270	36	TSNP10-1
<b>NEW!</b> <a href="#">BGSA143ML10</a>	SP4T <sup>8)</sup>	on request	1.65...1.95	1.65...1.95	0.16/0.5	27/20	1.1	160	42	TSLP-10

Notes: 1) Digital Control Voltage; 2) IL = Insertion Loss at 1.0 / 2.0 GHz (depending on RF Port); 3) Isolation at 1.0 / 2.0 GHz;  
 4) In ON state (RF1 / RF2 / RF3); 5) In OFF state (RF1 / RF2 / RF3); 6) Max RF Voltage;  
 7) also can be used as SP4T 8)With shunt switches(Resonance stopper) 9)Please visit [www.infineon.com/rfswitches](http://www.infineon.com/rfswitches) for alternative devices.

### 3.4 PIN Diode Switches for Wireless Systems

An alternative to the CMOS and GaAs switches are switches with PIN diodes. Where integrated solutions are not available due to limitations like operating frequency or special configuration, PIN diodes offer the flexibility to build an application-tailored switch. Basic PIN diode switch configurations are shown below. By combining multiple of those building blocks complex switching schemes or improved switch characteristics can be achieved.

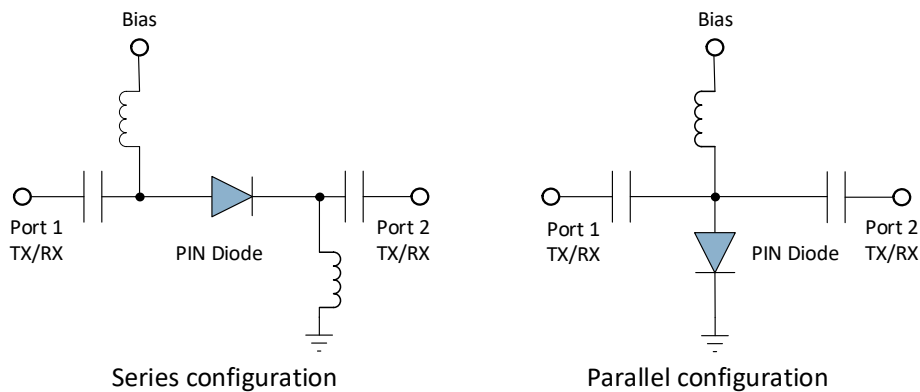

**Figure 28 Basic PIN diode switch configurations**

#### Key Parameters of PIN Diodes switches:

##### *Insertion Loss (IL) and Isolation*

These parameters are determined mainly by the forward resistance of the PIN diode and its capacitance. Forward bias brings the PIN diode in the low impedance state with diode resistance dependent on bias current. Zero or negative (reverse) bias brings the PIN diode into the high impedance state. In this condition the junction capacitance is the key parameter. That corresponds with Insertion loss and isolation as summarized below:

	Series configuration	Parallel configuration
Forward bias	Low insertion loss	High isolation
Zero or negative bias	High isolation	Low insertion loss

Infineon’s diodes are optimized for both low capacitance and low forward resistance.

##### *Switching Time*

The carrier life time in a PIN diode dominates the switching speed, i.e. the time required to switch the diode from a low-impedance forward bias state to a high-impedance reverse bias state.

### RF PIN Diodes

Product	Application Note	$r_F^{(1)}$ [ $\Omega$ ]	@ $I_F$ [mA]	$r_F^{(1)}$ [ $\Omega$ ]	@ $I_F$ [mA]	$C_T^{(2)}$ [pF]	@ $V_R$ [V]	$CC_1^3$ [ns]	Package
<a href="#">BAR90-02EL</a> <a href="#">BAR90-02ELS</a>	-	1.3	3.0	0.8	10.0	0.25	1.0	750	TSLP-2-19 TSSLP-2-3
<a href="#">BAR64-02EL</a>	-	12.5	1	2.1	10	0.23	20	1550	TSLP-2-19
<a href="#">BAR64-04</a> <a href="#">BAR64-05</a> <a href="#">BAR64-06</a>	-	12.5	1	2.1	10	0.23	20	1550	SOT23
<a href="#">BAR64-04W</a> <a href="#">BAR64-05W</a> <a href="#">BAR64-06W</a>	-	12.5	1	2.1	10	0.23	20	1550	SOT323

Notes: 1) at 100 MHz; 2) at 1 MHz;  
3) The charge carrier life time between the forward bias of  $I_F = 10$  mA and reverse bias of  $I_R = 6$  or 3 mA;

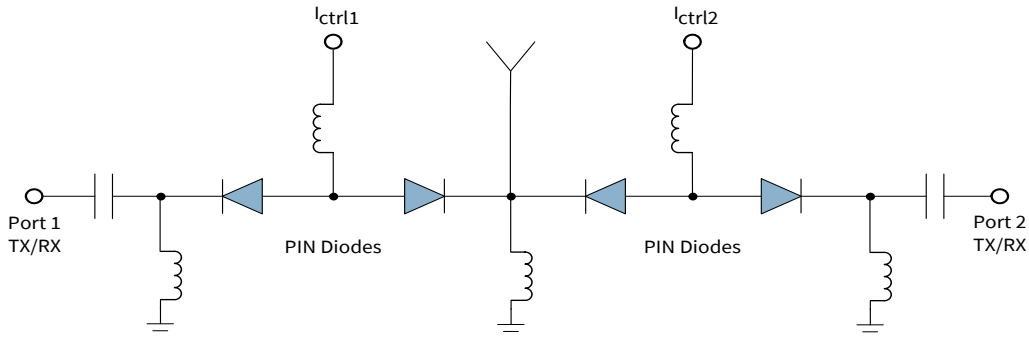

**Figure 29 Application a: Ultra-Low-Harmonic-Generation band switch with PIN-diodes**

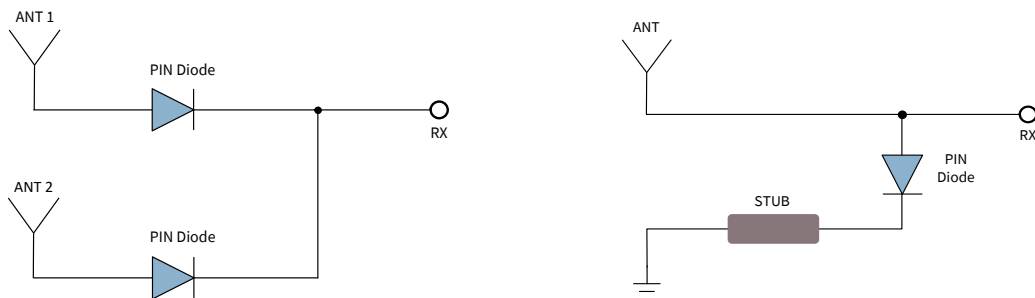

**Antenna selection**

**Antenna effective length modification**

**Figure 30 Application b,c: Antenna selection and length modification with PIN-diodes**

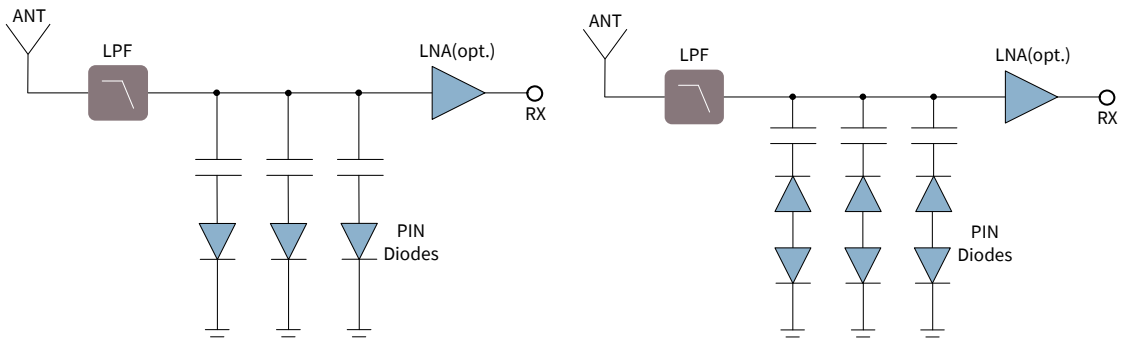

**Tunable antenna with moderate IMD generation**

**Tunable antenna with low IMD generation**

**Figure 31 Application d: Antenna tuning with PIN-diodes**

## 4 Low Noise Amplifiers for Mobile Phone RF Front-Ends

Infineon Technologies is one of the leading companies for Low Noise Amplifiers (LNAs). Infineon’s LNA portfolios are based on Silicon Germanium Carbon (SiGe:C) bipolar technology.

The Figure 32 shows a block diagram of a 3G/4G modem for a smartphone RF Front-End (FE). The LNAs are located in the diversity and main antenna paths of the phone. In very weak signal environment, LNAs can double data rates compared to solutions without LNAs. High linearity assures optimal signal reception even with poorly isolated antennas and long line losses between antennas and transceivers.

Infineon’s Monolithic Microwave Integrated Circuit (MMIC) LNAs and LNA Multiplexer Modules (LMM) with their excellent low noise figures enhance the sensitivity of the RF modem by about 3 dB and offer system layout flexibility by suppressing noise contribution from losses of signal lines and from the SAW filters as well as the receiver.

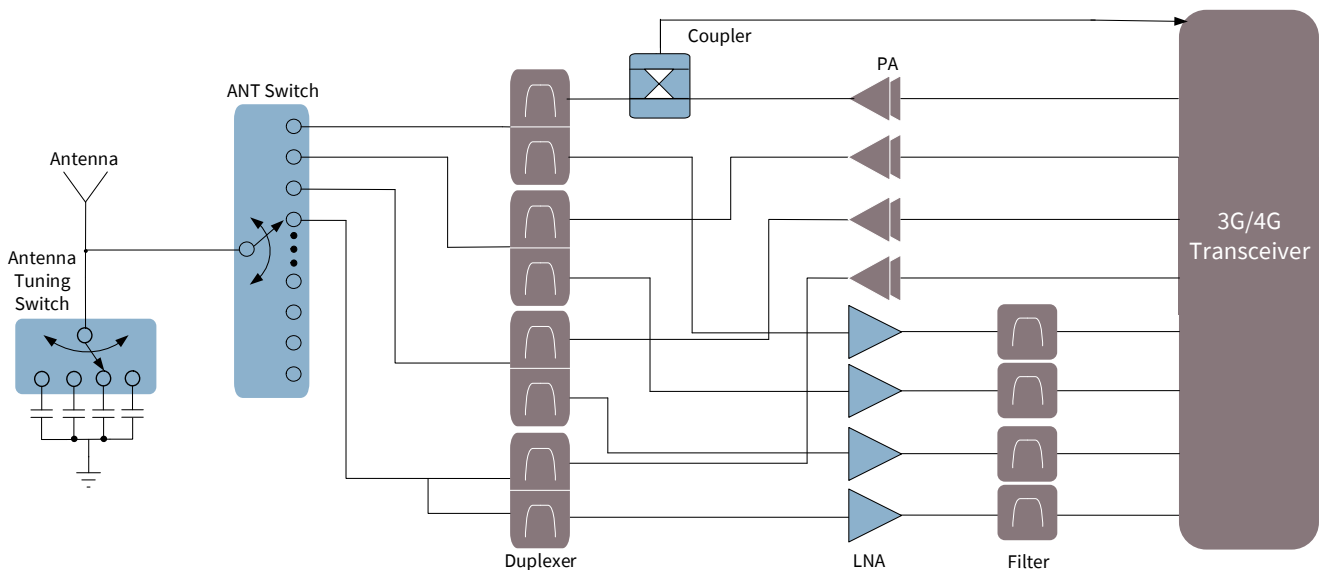

Figure 32 Block diagram of a 3G/4G modem

Infineon’s latest LTE/LTE-A LNA family consists of single-band LNAs (e.g. BGA5X1BN6), multi-gain LNAs (e.g. BGAX1A10) and LNA Multiplexer Modules (LMMs) (e.g. BGM1XXBA9). These products have ultra-low Noise Figures (NFs), and enough gain and high linearity needed to help smartphone designers to overcome the challenges of LTE/LTE-A technology.

### 4.1 Key Challenges of LNAs in Mobile Applications

Satisfying an increasing demand for data bandwidth, the recently launched 4G LTE-A smart phones can support data rates of up to 1 Gbps. Such higher requirements are met by using advanced Multiple Input Multiple Output (MIMO) techniques and wider bandwidths up to 100 MHz enabled by Carrier Aggregation (CA). LTE-A can support up to 5 bands of CA by three component CA scenarios: Intra-band contiguous, intra-band non-contiguous and inter-band non-contiguous aggregation.

They present new challenges to RF FE designers, such as interference from co-existing bands and harmonic generation. Smart LTE and LTE-A LNAs with the following features can address these requirements to achieve outstanding performance:

**Low Noise Figure (NF):** An external LNA or LNA module boosts the sensitivity of the system by reducing the overall NF. Due to size constraints, the modem antenna and the receiver FE cannot always be placed close to the transceiver Integrated Circuit (IC). The path loss in front of the integrated LNA on the transceiver IC increases the system NF significantly. An external LNA physically close to the antenna can help to eliminate the path loss and reduce the system NF. The sensitivity can be improved by several dB, which means a significant increase in the connectivity range.

**High Linearity (1-dB compression point  $P_{1dB}$  and 3<sup>rd</sup>-order intercept point  $IP_3$ ):** An increased number of bands at the receiver input create strong interference, leading to high requirements for linearity characteristics such as high input 1-dB compression point, 2<sup>nd</sup> intermodulation (IMD2) products and input 3<sup>rd</sup> intercept point ( $IP_3$ ) performance.

**Low Power Consumption:** Power consumption is even more important in today's smartphones. The latest LTE-A uses enhanced MIMO techniques with up to 8 DL streams and 4 UL streams. Infineon's LNAs and LNA modules have low supply current and an integrated on/off feature that reduces power consumption and increases standby time for cellular handsets or other portable battery-operated wireless applications.

**High Integration and Simple Control Interface:** The demand for size and cost reduction and performance enhancement with ease of use and low parts count is very important in existing and future generation smartphones. Our MMIC LNAs are highly integrated with input and output either matched or pre-matched,

built-in temperature and supply voltage stabilization, and a fully ESD-protected circuit design to ensure stable operation and a simple control interface.

### 4.2 Single-band LNAs and Multiple-band LNA Banks

#### 4.2.1 Single-band LNAs

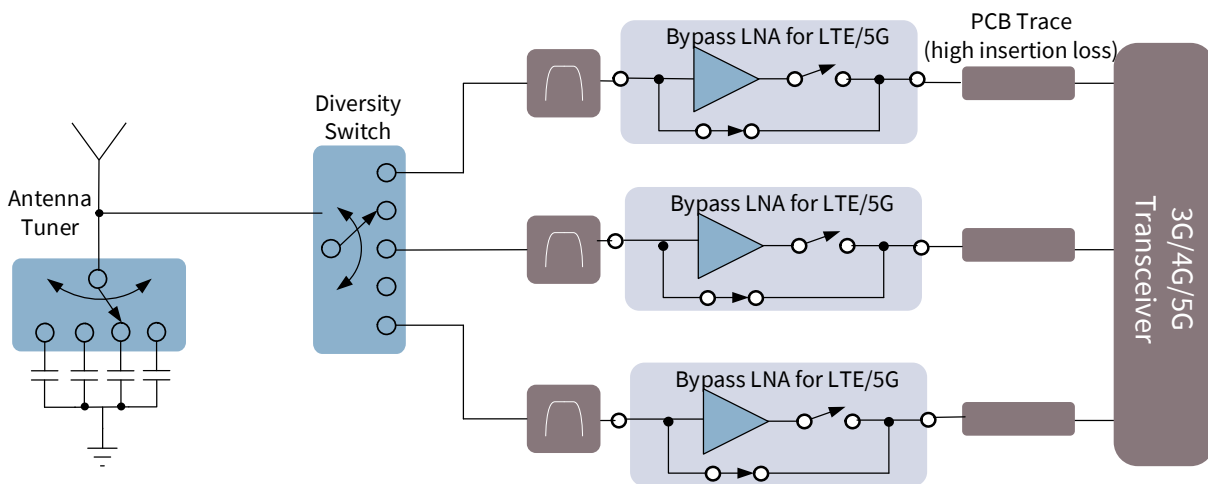

**Figure 33 Three single-band LNAs implemented in the diversity path**

#### Single-band LTE-A MMIC LNAs

Product	Application note	Freq. Range [MHz]	Gain [dB]	NF [dB]	IP <sub>-1dB</sub> [dBm]	IIP <sub>3</sub> [dBm]	Supply [V]	Current [mA]	Package
<a href="#">BGA7L1N6</a>	<a href="#">AN351</a> <a href="#">AN364</a> <a href="#">AN404</a>	728-960	13.0	0.9	-6	-1	1.5...3.3	4.9	TSNP-6-2
<a href="#">BGA7M1N6</a>	<a href="#">AN350</a> <a href="#">AN371</a> <a href="#">AN405</a> <a href="#">AN411</a>	1805-2200	13.0	0.7	-3	7	1.5...3.3	4.9	TSNP-6-2
<a href="#">BGA7H1N6</a>	<a href="#">AN349</a> <a href="#">AN365</a> <a href="#">AN406</a> <a href="#">AN432</a>	2300-2690	13.0	0.7	-4	6	1.5...3.3	4.9	TSNP-6-2

Notes: Please visit [www.infineon.com/ltelna](http://www.infineon.com/ltelna) for alternative devices.

### Single-band 3G/4G MMIC LNAs with Bypass Function

NEW!

NEW!

NEW!

NEW!

NEW!

NEW!

Product	Freq. Range [MHz]	Gain <sup>2)</sup> [dB]	NF <sup>2)</sup> [dB]	IP <sub>-1dB</sub> <sup>2)</sup> [dBm]	IIP <sub>3</sub> <sup>2)</sup> [dBm]	Supply [V]	Current <sup>2)</sup> [mA]	Package
<a href="#">BGA5L1BN6</a> <sup>1)</sup>	600 - 1000	18.5/-2.7	0.7/2.7	-20/+2	-7/+11	1.5...3.6	8.2/0.085	TSNP-6-2
<a href="#">BGA5M1BN6</a> <sup>1)</sup>	1805-2200	19.3/-4.7	0.65/4.7	-16/-2	-7/+6	1.5...3.6	10.3/0.087	TSNP-6-2
<a href="#">BGA5H1BN6</a> <sup>1)</sup>	2300-2690	18.1/-5.2	0.7/5.2	-17/-3	-7/+6	1.5...3.6	8.2/0.085	TSNP-6-2
<a href="#">BGA7L1BN6</a> <sup>1)</sup>	716-960	13.6/-2.2	0.75/1.8	-1/+6	+5/+18	1.5...3.3	4.9/0.09	TSNP-6-2
<a href="#">BGA7H1BN6</a> <sup>1) 5)</sup>	1805-2690	12.3/	0.85/	-1/+5	+5/+16	1.5...3.3	4.3/0.09	TSNP-6-2
<a href="#">BGA8L1BN6</a> <sup>1) 4)</sup>	703-960	13.2/-2.6	0.75/2.6	-3/+8	+1/+21	1.6...3.1	5.7/0.2	TSNP-6-2
<a href="#">BGA8G1BN6</a>	1452 - 1610	14.6/-4.1	0.8/4.1	-8/+8	1/+20	1.6...3.1	4.7/0.2	TSNP-6-2
<a href="#">BGA8H1BN6</a> <sup>1) 4)</sup>	1805-2690	13.5/-3.6	0.85/3.6	-5/+8	2/+20	1.6...3.1	6.0/0.2	TSNP-6-2
<a href="#">BGA8V1BN6</a> <sup>1) 4)</sup>	3400 - 3800	15.0/-5.3	1.2/5.3	-15/-3	-3/+6	1.6...3.1	4.2/0.2	TSNP-6-2
<a href="#">BGA8U1BN6</a>	5150 - 5850	14.0/-5.0	1.6/5.0	-15/-5	-3/+11	1.6...3.1	4.0/0.2	TSNP-6-2

Notes: 1) LNA with two gain modes (high-gain/low-gain); 2) Values in high-gain (HG) / low-gain (LG) mode; 3) Please visit [www.infineon.com/ltelna](http://www.infineon.com/ltelna) for alternative devices.

### 4.2.2 MIPI-RFFE LNA with Gain Control

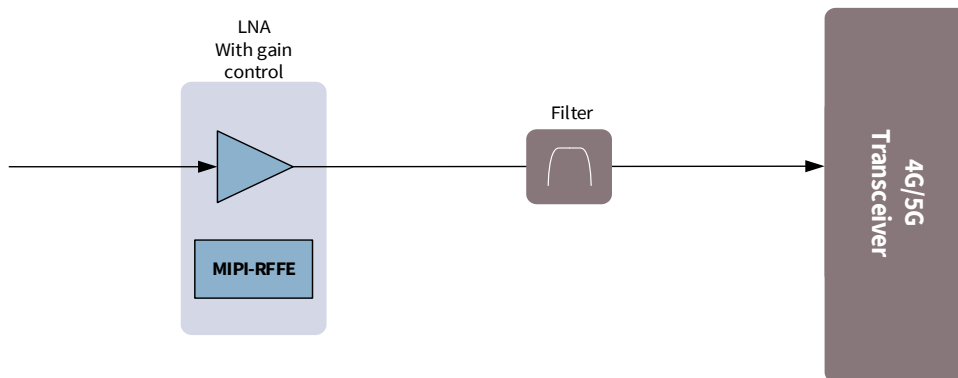

Figure 34 Multi gain state LNA implemented in the main path

### MIPI LNA with Gain Control for 4G/5G (Product Details on Request)

NEW!

NEW!

Product	Freq. Range [MHz]	Gain [dB]	NF [dB]	IP <sub>-1dB</sub> [dBm]	IIP <sub>3</sub> [dBm]	Supply [V]	Current [mA]	Package
<a href="#">BGAU1A10</a> <sup>1)</sup>	3400-3800	18.0 <sup>2)</sup>	1.3 <sup>2)</sup>	-13 <sup>2)</sup>	-3.0 <sup>2)</sup>	1.7...1.9 <sup>7)</sup>	5.0/0.07 <sup>7)</sup>	ATSLP-10-1
		15.3 <sup>3)</sup>	1.4 <sup>3)</sup>	-13 <sup>3)</sup>	-3.0 <sup>3)</sup>			
		8.9 <sup>4)</sup>	1.5 <sup>4)</sup>	-6.0 <sup>4)</sup>	+1.0 <sup>4)</sup>			
		-0.7 <sup>5)</sup>	10.1 <sup>5)</sup>	+3.0 <sup>5)</sup>	+9.0 <sup>5)</sup>			
		-3.9 <sup>6)</sup>	3.9 <sup>6)</sup>		+32.0 <sup>6)</sup>			
<a href="#">BGAU1A10</a> <sup>1)</sup>	5150-5920	20.5 <sup>2)</sup>	1.7 <sup>2)</sup>	-18 <sup>2)</sup>	-8.0 <sup>2)</sup>	1.7...1.9 <sup>7)</sup>	5.0/0.1 <sup>7)</sup>	ATSLP-10-1
		17.5 <sup>3)</sup>	1.7 <sup>3)</sup>	-17 <sup>3)</sup>	-8.0 <sup>3)</sup>			
		9.0 <sup>4)</sup>	1.6 <sup>4)</sup>	-6.0 <sup>4)</sup>	-2.0 <sup>4)</sup>			
		-0.3 <sup>5)</sup>	9.9 <sup>5)</sup>	+3.0 <sup>5)</sup>	+6.0 <sup>5)</sup>			
		-6.5 <sup>6)</sup>	6.5 <sup>6)</sup>		+30.0 <sup>6)</sup>			

Notes: 1) On request; 2) Gain State: G0, 3) Gain State: G1, 4) Gain State: G2, 5) Gain State: G3, 6) Gain State: Bypass 7) Based on Preliminary datasheet

### 4.3 LNA Multiplexer Modules (LMM) for Carrier Aggregation

Time-division duplexing (TDD)-mode LTE systems combined with Frequency-Division Duplexing (FDD)-mode LTE systems are steadily gaining importance. As end users continue to download more and more data anytime and anywhere, there is an increasing need for more bandwidth and an additional receiver channel called the “diversity path” in smartphones. Diversity exploits the multipath propagation phenomenon of microwaves in order to enhance the reception of cellular signals. In most mobile phones, there is a second antenna for the diversity path, the diversity antenna.

The diversity antenna is usually located far from the main antenna and the transceiver IC. The received signal therefore undergoes losses along the path from the diversity switch to the transceiver IC. It is necessary to use an LNA / LNA multiplexer module closer to the diversity switch to overcome losses and enhance the sensitivity of the system. LNA / LNA multiplexer modules improve receiver performance significantly by reducing the noise from the long route line between the diversity antenna and the transceiver IC, and by compensating for the losses incurred due to the band pass filter and NF of the transceiver.

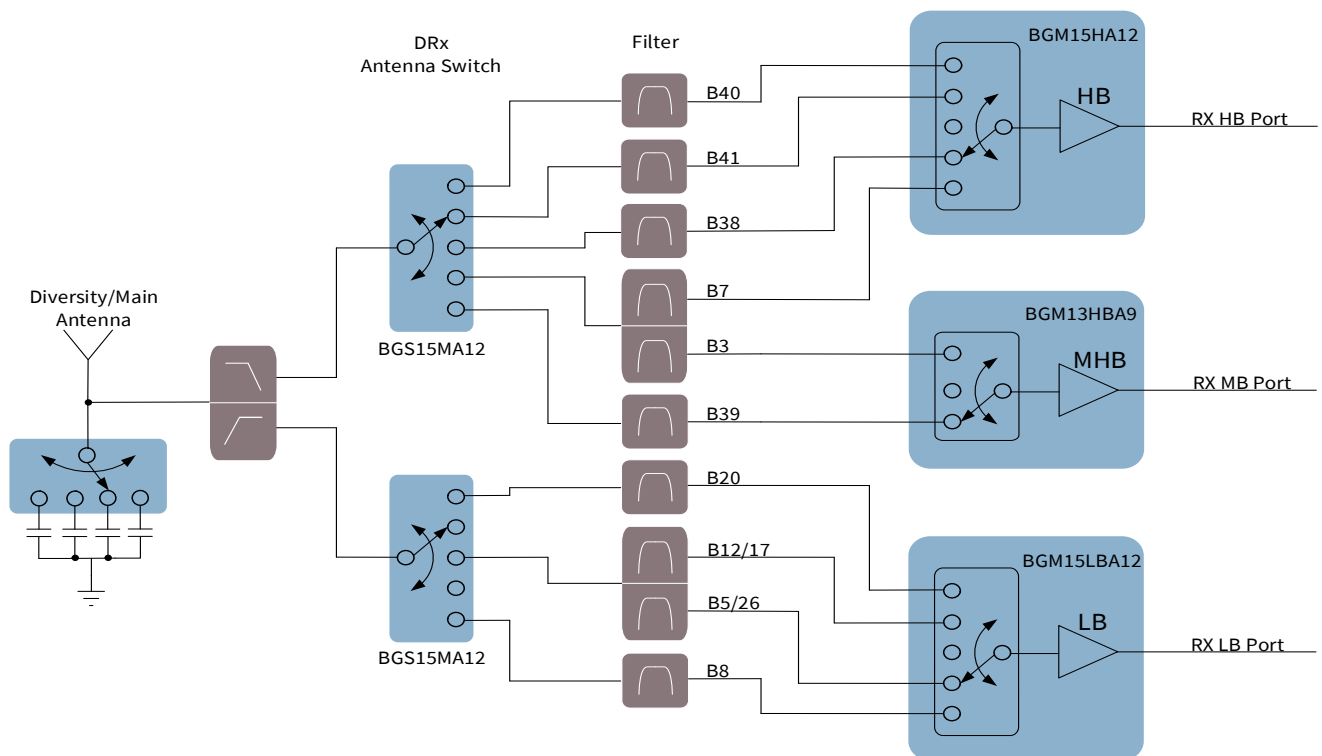

**Figure 35 LNA multiplexer module implemented in the diversity path**

The LNA Multiplexer Modules (LMMs) consists of a sPxT switch and a broadband LNA. The LMM can support as many individual bands as the number of pins for single-carrier operation as well as carrier aggregation mode.

# Application Guide for Mobile Communication



## Low Noise Amplifiers for Mobile Phone RF Front-Ends

Each letter in the LMM series name denotes a different frequency band: L for low-band (0.7 GHz to 1.0 GHz); M for mid-band (1.7 GHz to 2.2 GHz); H for high-band (2.3 GHz to 2.7 GHz); V for very high-band (3.3 GHz to 3.8 GHz); and U for Ultra-band (5.15 GHz to 5.85 GHz). All devices are programmable using RFFE MIPI.

### LNA Multiplexer Modules for LTE-Advanced Applications

	Product	Description	Application Note	Freq. Range [MHz]	Gain [dB]	NF [dB]	IP <sub>-1dB</sub> [dBm]	IIP <sub>3</sub> [dBm]	Supply [V]	Current [mA]	Package
NEW!	<a href="#">BGM12LBA9</a>	SPDT+LNA	on request	703-960	13.3/-3.2	0.85/3.2	-5	+3/+17	1.6-3.1	5.2-0.2	ATSLP-9
NEW!	<a href="#">BGM13GBA9</a>	SP3T+LNA	on request	1452-1610	14.8/-3.4	0.85/3.4	-8	-1/+15	1.6-3.1	5.2-0.2	ATSLP-9
NEW!	<a href="#">BGM13HBA9</a>	SP3T+LNA	on request	1805-2690	14.3/-5.3	0.9/5.3	-12	-2/+20	1.6-3.1	5.1-0.2	ATSLP-9
	<a href="#">BGM15HA12</a>	SP5T+LNA	on request	1805-2690	13.5/-3.8	1.8/3.8	-4	-5/+19	1.7-3.1	5.0-0.2	ATSLP-12
	<a href="#">BGM15LA12</a> <sup>1)</sup>	SP5T+LNA	<a href="#">AN373</a> <sup>1)</sup>	700-1000	15.0	1.1	-2.5	6.0	2.2-3.3	4.8	ATSLP-12
NEW!	<a href="#">BGM15LBA12</a> <sup>2)</sup>	SP5T+LNA	on request	703-960	12.8/-3.0	1.3/3.0	-4	-6	1.7-3.1	5.0-0.2	ATSLP-12
	<a href="#">BGM15MA12</a> <sup>1)</sup>	SP5T+LNA	<a href="#">AN374</a> <sup>1)</sup> <a href="#">AN399</a> <sup>1)</sup> <a href="#">TR1180</a> <sup>1)</sup>	1700-2200	15.5	1.2	-9	6.0	2.2-3.3	4.7	ATSLP-12
	<a href="#">BGM15HA12</a> <sup>1)</sup>	SP5T+LNA	<a href="#">AN375</a> <sup>1)</sup> <a href="#">AN340</a> <a href="#">AN409</a> <a href="#">TR1181</a> <sup>1)</sup>	2300-2700	14.4	1.2	-4	6.0	2.2-3.3	4.9	ATSLP-12
NEW!	<a href="#">BGM17HBA15</a>	SP7T+LNA	on request	1805-2690	13.5/-3.8	1.8	-4	-5	1.7-3.1	5.0-0.2	ATSLP-15
NEW!	<a href="#">BGM17LBA15</a>	SP7T+LNA	on request	703-960	12.8/-3.0	1.3	-4	-6	1.7-3.1	5.0-0.2	ATSLP-15

Notes: 1) On request; 2) LNA with bypass; 3) Please visit [www.infineon.com/ltelna](http://www.infineon.com/ltelna) for alternative devices.

### 4.4 LNAs for 3.5 GHz TD-LTE

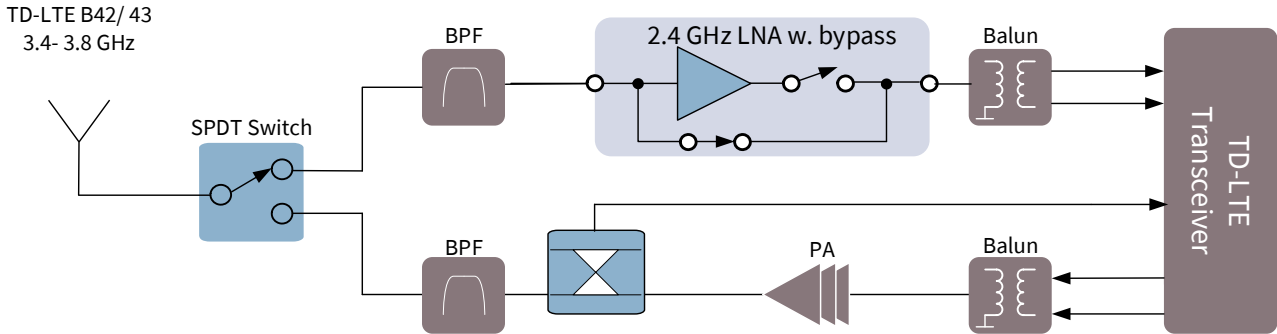

Figure 36 LNAs for 3.5 GHz TD-LTE

#### RF MMIC LNAs

Product	Application Note	Gain [dB]	NF [dB]	IP <sub>-1dB</sub> [dBm]	IIP <sub>3</sub> [dBm]	Supply [V]	Current [mA]	Package
<a href="#">BGA8V1BN6</a>	on request	15.0/-5.3	1.2/5.3	-15/-3	-3/+6	1.6...3.1	4.2/0.2	TSNP-6-2
<a href="#">BGAV1A10</a> <sup>1)</sup>	on request	18.0 <sup>2)</sup>	1.3 <sup>2)</sup>	-13 <sup>2)</sup>	-3.0 <sup>2)</sup>	1.7...1.9 <sup>7)</sup>	5.0/0.07 <sup>7)</sup>	ATSLP-10-1
		15.3 <sup>3)</sup>	1.4 <sup>3)</sup>	-13 <sup>3)</sup>	-3.0 <sup>3)</sup>			
		8.9 <sup>4)</sup>	1.5 <sup>4)</sup>	-6.0 <sup>4)</sup>	+1.0 <sup>4)</sup>			
		-0.7 <sup>5)</sup>	10.1 <sup>5)</sup>	+3.0 <sup>5)</sup>	+9.0 <sup>5)</sup>			
		-3.9 <sup>6)</sup>	3.9 <sup>6)</sup>		+32.0 <sup>6)</sup>			
<a href="#">BGB707L7ESD</a>	<a href="#">TR171</a> <sup>1)</sup>	14.3	1.3	-8	-5	2.8	5.4	TSLP-7-1

Note: 1) On request; 2) Gain State: G0; 3) Gain State: G1; 4) Gain State: G2; 5) Gain State: G3; 6) Gain State: Bypass 7) Based on Preliminary datasheet

#### RF CMOS TX/RX Switches

Product	Type	App. Note	Supply [V]	V <sub>ctrl</sub> <sup>1)</sup> [V]	IL <sup>2)</sup> [dB]	Isolation [dB]	P <sub>-0.1dB</sub> <sup>3)</sup> [dBm]	P <sub>in,max</sub> <sup>4)</sup> [dBm]	Ctrl. Int. <sup>5)</sup>	Package
<a href="#">BGS12PL6</a>	SPDT	<a href="#">AN319</a>	2.4...3.6	1.4...3.6	0.77	22	38	35	GPIO	TSLP-6-4

Notes: 1) Digital control voltage; 2) IL = Insertion Loss; 3) 0.1dB compression point; 4) Maximum input power; 5) Control interface; 6) Please visit [www.infineon.com/rfswitches](http://www.infineon.com/rfswitches) for alternative devices.

## 5 Global Navigation Satellite Systems

Global Navigation Satellite Systems (GNSSs) are among the widest used applications in the electronic industry. Today, four GNSS systems are in operation: GPS, GLONASS, BDS, and Galileo. Main applications include Personal Navigation Devices (PND), GNSS-enabled mobile phones, and GNSS-enabled wearable devices.

### 5.1 Application and Technical Trends

Most GNSS systems operate in the upper L band (1559 MHz to 1610 MHz). Recently, GNSS applications in the lower L bands (1164 MHz to 1299 MHz) have started to emerge. The lower L bands include GPS L5 / GLONASS G3/ Galileo E5 bands (1164 MHz to 1214 MHz) and GPS L2 / GLONASS G2 / Galileo E6 bands (1215 MHz to 1300 MHz). The L5 band hosts a civilian safety of life signal, and is intended to provide a means of radio navigation secure and robust enough for life critical applications, such as aircraft precision approach guidance. India's Indian Regional Navigation Satellite System (IRNSS) also operates in the L5 band. The L2 band has been used for high-preciseness location navigation.

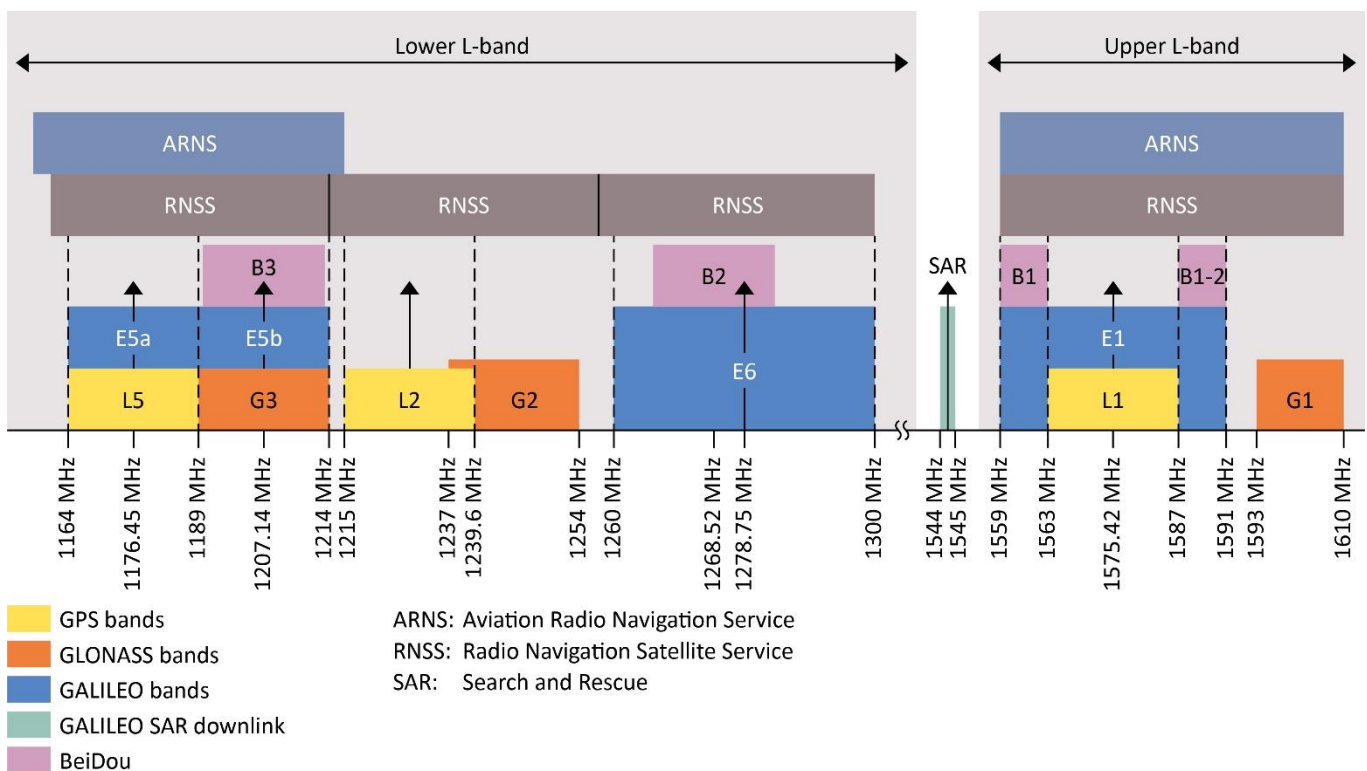

Figure 37 Frequency allocation GNSS systems, upper L bands and lower L bands

## 5.2 Key Challenges for Modern GNSS Reception in Mobile Devices

The main technical challenges for GNSS-enabled mobile phone devices are:

- (1) Receive path sensitivity in the presence of weak incoming GNSS signals
- (2) NF degradation caused by co-existing cellular jamming.
- (3) Signal interferences with the GNSS signal caused by harmonic or intermodulation signals generated from co-existing RF signals.

### **Noise Figure degradation due to high power of jammer signal**

High power jammer signals may leak into the GNSS receiver and affect the receiver's sensitivity by overdriving the receiver's LNA. This presents a major challenge to RF FE designers to maintain the receiver's sensitivity to weak incoming GNSS signals. It is important to use an external LNA with very good noise performance in the presence of strong interfering signals. The LNA needs to exhibit outstanding P1dB against Out-of-band (OoB) jammer signals so that it is not desensitized. The Figure 38 shows the NF degradation of Infineon's LNA BGA824N6 due to high-power incoming jammer signals.

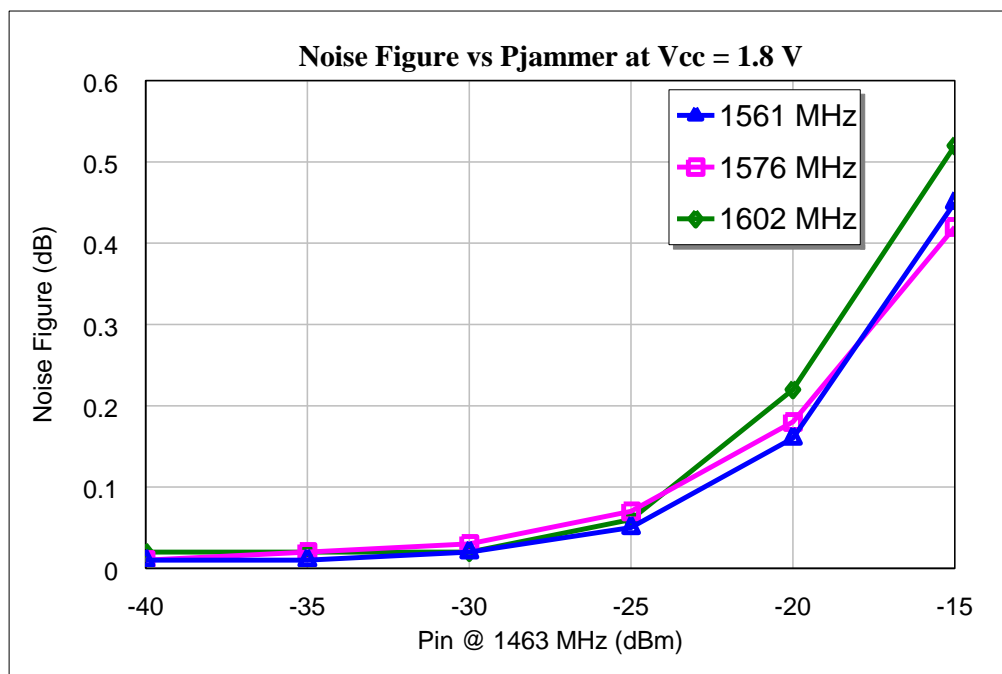
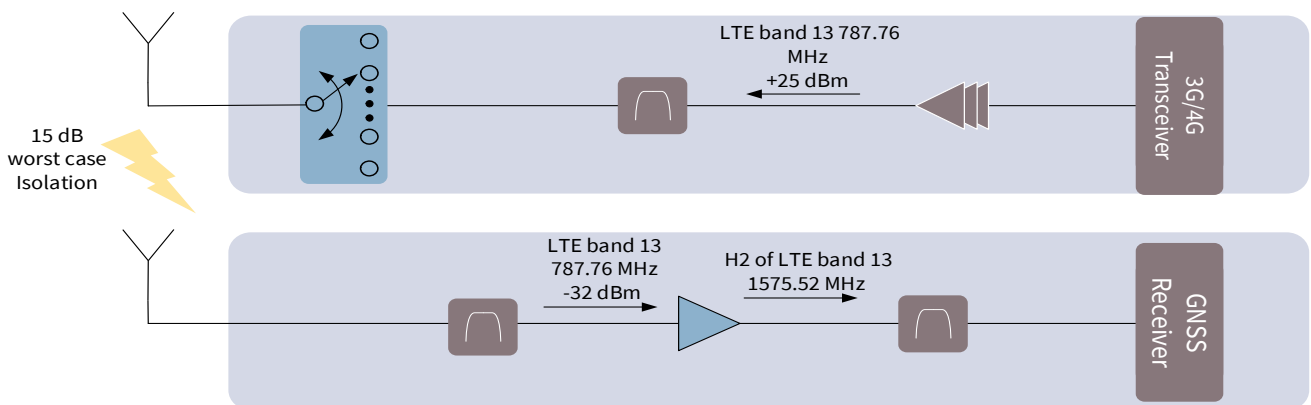

**Figure 38 Noise figure desensitization effect caused by jammer signal**

**LTE Band 13 / Band 14 interference**

The 2<sup>nd</sup> harmonic of LTE band 13 and band 14 (777 MHz / 788 MHz) is located in the GNSS band at 1574 MHz / 1576 MHz. The Figure 39 depicts the interference measurement of LTE band-13 with the GNSS band of 1575 MHz.

Considering a worst-case isolation of 15 dB between the both antennas, jammer frequency  $f_{LTE} = 787.76$  MHz, the power of the LTE band 13 jammer is -32 dBm at the input of GNSS LNA. After inserting a band 13 rejection filter at LNA input, the second harmonic at  $f_{H2} = 1575.52$  MHz will be reduced to -110 dBm at LNA output.



**Figure 39** Block diagram for the LTE Band 13 second harmonic interference

**Out-of-band interference**

Because GNSS and cellular systems coexist in a compact area in a mobile phone, coupling from cellular transmitter to the GNSS receive path results in intermixing of other high frequency signals in GNSS FE devices, for example, intermodulation between LTE band 2 and band 3 signals, intermodulation between LTE band 5 and WLAN 2.4 GHz signals, etc.

In the example below, LTE Band 3 Signal ( $f_{1IN}$ ) and LTE Band 2 Signal ( $f_{2IN}$ ) produce third-order intermodulation products at GPS frequencies. This effect desensitizes the GPS receiver and decreases its performance. This may be expressed via the Out-of-band Input IP3 (OoB IIP3).

$$OoB\ IIP3 = P1_{IN} + [P2_{IN} - (IM3_{out\_GPS} - Gain_{at\ GPS})]/2 \quad \text{----- (1)}$$

When  $f_{1IN} = 1712.7$  MHz and power  $P1_{IN} = -25$  dBm, and  $f_{2IN} = 1850$  MHz and power  $P2_{IN} = -25$  dBm are used, the 3<sup>rd</sup>-order intermodulation product,  $2 \times f_{1IN} - f_{2IN}$ , is located at 1575.4 MHz. Using the equation 1, the OoB IIP3 can be calculated as

$$OoB\ IIP3 = -25 + [-25 - (-78.2 - 17.0^1)]/2 = 10.1\ dBm$$

(Note: 1) Gain at GPS is from BGA824N6

This value is 3 dBm above the specified value for mobile GNSS applications, e.g. about +7 dBm.

### **5.3 Key Features of GNSS Front-End Devices**

Infineon Technologies offers a wide product portfolio of RF FE solutions for GNSSs:

- Monolithic Microwave Integrated Circuit (MMIC) Low Noise Amplifiers (LNA)
- Transient Voltage Suppression (TVS) Diodes
- RF Switches

The key features of the GNSS LNAs are:

#### ***Low Noise Figure & High Gain***

The power levels of satellite signals received by a GNSS receiver are as low as -130 dBm. An external LNA with low NF and high gain helps to boost the system's Signal to Noise Ratio (SNR), and thus reduces the Time-To-First Fix (TTFF).

#### ***High Linearity against Out-of-Band Signals***

To enhance interference immunity of GNSS systems against coexisting cellular signals, devices with robustness against OoB interference are required e.g. OoB IM2, OoB IM3.

#### ***Low Current Consumption***

Low power consumption is required to maximize the operating time of battery-operated devices. Infineon's LNAs have an integrated power on/off feature that increases stand-by time for GNSS enabled devices. The GNSS LNA BGA123L4 consumes less power than nearly all other GNSS LNAs; it has low NF and its power consumption as low as 1.3mW.

Please visit [www.infineon.com/gnss](http://www.infineon.com/gnss) for more details on products for navigation in mobile phones and portable devices.

## 5.4 RF Front-End Devices for GNSS

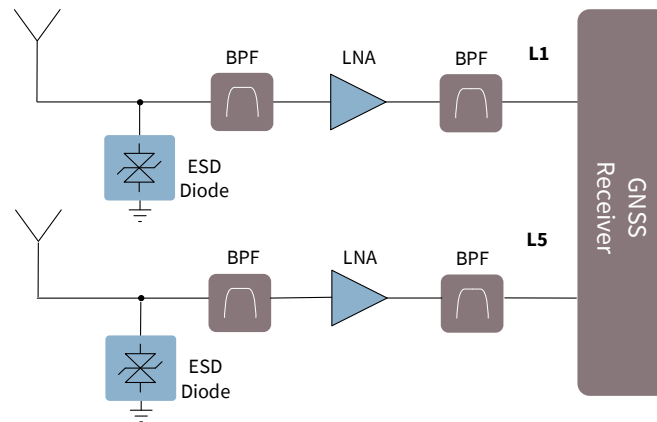

Figure 40 GNSS system supporting L1 and L5 bands

### RF MMIC LNAs for GNSS L1 Band

Product	Application Note	Gain <sup>1)</sup> [dB]	NF <sup>1)</sup> [dB]	IP <sub>-1dB</sub> <sup>1)</sup> [dBm]	Oob_IIP <sub>3</sub> <sup>2)</sup> [dBm]	Supply [V]	Current <sup>1)</sup> [mA]	Package
BGA123L4	AN551 <sup>4)</sup>	18.3	0.75	-15	-7	1.1...3.6	1.1	TSLP-4-11
BGA524N6	AN346 AN400 AN420	19.6 19.6 16.8	0.8 0.65 1.07	-12 -12 -12	-5 -6 -8	1.5...3.3	2.5 2.5 1.6	TSNP-6-2
BGA824N6	AN325 AN334	17.0 16.4	0.65 0.9	-7 -9	8 7	1.5...3.6	3.9 4.0	TSNP-6-2
BGA725L6	AN280	19.9	0.7	-15	-1	1.5...3.6	3.9	TSLP-6-2

Notes: 1) Supply voltage at 1.8 V, with 0402 LQW inductor for matching 2) input frequency at 1712.7MHz, 1850 MHz; Pin -20 dBm; measured at 1575.4 MHz;  
3) Please visit [www.infineon.com/gnss](http://www.infineon.com/gnss) for alternative device 4) on request

### RF MMIC LNAs for GNSS L2 Band / L5 Band

Product	Application Note	Gain <sup>1)</sup> [dB]	NF <sup>1)</sup> [dB]	IP <sub>-1dB</sub> <sup>1)</sup> [dBm]	Oob_IIP <sub>3</sub> <sup>2)</sup> [dBm]	Supply [V]	Current <sup>1)</sup> [mA]	Package
BGA123L4	AN572 <sup>4)</sup>	16.2	0.85	-19	-12	1.1...3.6	1.1	TSLP-4-11
BGA524N6	AN418 AN537 <sup>4)</sup>	17.8 18.2	0.8 0.75	-14 -15	- -	1.5...3.3	2.5 2.5	TSNP-6-2
BGA824N6	AN533 <sup>4)</sup> AN542 <sup>4)</sup>	17.5 17.6	0.75 0.75	-12 -12	6 6	1.5...3.6	4.1 4.1	TSNP-6-2
BGA855N6	on request	17.5	0.65	-	-	1.5...3.3	4.8	TSNP-6-2

Notes: 1) Supply voltage at 1.8 V, with 0402 LQW inductor for matching 2) input frequency at 1850MHz, 2500 MHz; Pin -25 dBm, measured at 1200 MHz;  
3) Please visit [www.infineon.com/gnss](http://www.infineon.com/gnss) for alternative devices 4) on request

### TVS Diodes for Antenna ESD Protection

Product	Application	V <sub>RWM</sub> [V]	ESD <sup>1)</sup> [kV]	V <sub>CL</sub> <sup>2)</sup> [V <sub>CL</sub> ]@[A]	R <sub>dyn</sub> <sup>3)</sup> [Ω]	I <sub>PP</sub> <sup>4)</sup> [A]	V <sub>CL</sub> <sup>5)</sup> [V]	C <sub>T</sub> <sup>6)</sup> [pF]	Protected Lines	Package
ESD106-B1-W0201	med. P <sub>RF</sub>	±5.5	±12	±16@±8 ±25@±16	1.1	1.5	10	0.13	1	WLL-2-3
ESD119-B1-W01005 ESD130-B1-W0201	med. P <sub>RF</sub> AN392	±5.5	±25	±20@±16 ±31@±30	0.8	1 2.5	11 14	0.3	1	WLL-2-2 WLL-2-1
ESD131-B1-W0201 ESD133-B1-W01005	High-Speed Interfaces	±5.5	±20	±8.5@±8 ±13@±16	0.6 0.56	3	5.5	0.25 0.23	1	WLL-2-3 WLL-2-2

## 6 Wireless-LAN, Unlicensed LTE (LTE-U) and Licensed Assisted Access (LAA)

### 6.1 Wireless-LAN Applications

Connecting to Wireless Local Area Network (WLAN) or Wi-Fi is one of the most important functions in notebooks, smartphones, and tablet PCs. Wi-Fi conforming to IEEE 802.11b/g/n at 2.4 GHz has been widely implemented over many years. The crowded WLAN networks running at 2.4 GHz often have a lot of interference; as a result, Wi-Fi applications running at 5 to 6 GHz per IEEE 802.11a/ac/n are becoming more common. Wireless household devices such as home networking notebooks, mass data storage drives, and printers often now use 5-6 GHz Wi-Fi for high-speed connections.

With the arrival of new wireless devices such as tablets, Voice over Internet Protocol (VoIP) devices, game consoles, ebooks etc., the requirements for wireless data quality have become more stringent than ever. New WLAN standards are being developed to cater to these high-throughput requirements by using

- Higher-order modulation schemes
- Wider channel bandwidth
- Multiple data streams

Standard	Frequency Range	Data Rate	Count of Channels	Channel Bandwidth	Modulation Scheme	MIMO Streams
	[GHz]	[Mbps]		[MHz]		
<b>802.11</b>	2.4 – 2.5	2	14 <sup>1)</sup>	20	DSSS, FHSS	1
<b>802.11b</b>	2.4 – 2.5	11	14 <sup>1)</sup>	20	DSSS	1
<b>802.11g</b>	2.4 – 2.5	54	14 <sup>1)</sup>	20	OFDM, DSSS	1
<b>802.11n</b>	2.4 – 2.5	54	up to 14 <sup>1)</sup>	20, 40	OFDM	4
<b>802.11a</b>	5.1 – 5.9	54	42 <sup>2)</sup>	20	OFDM 64QAM	1
<b>802.11n</b>	5.1 – 5.9	600 (4x4 MIMO)	up to 42 <sup>2)</sup>	20, 40	OFDM	4
<b>802.11ac</b>	5.1 – 5.9	1300 (3 streams)	up to 42 <sup>2)</sup>	20, 40, 80, 160	256QAM	up to 8, MU-MIMO
<b>802.11ad</b>	57 - 64	up to 7000	--	50,100, 250 MHz up to 4 GHz	16QAM	--
<b>802.11af</b>	VHF & UHF bands 0.054 – 0.790	up to 35.6		6, 8	OFDM	4
<b>802.11ah</b>	Below 1GHz 0.755 - 0.928	Up to 8.67	-	1, 2, 4, 8, 16	OFDM	1

Table 2 Summary of 802.11 a/b/g/n/ac/ad/af/ah Standards

### **6.1.1 Key Features of WLAN Rx Front-End Devices**

Key performance metrics for any WLAN application are the speed of data transfer and coverage. These factors are greatly influenced by transmitter power, receiver sensitivity, noise, and interference.

#### ***Low Noise Figure***

A Wi-Fi router has to receive relatively weak signals from Wi-Fi enabled devices such as mobile phones. Therefore, it should have high sensitivity to detect a weak signal in the presence of strong interfering signals. The sensitivity of the receiver can be improved by using a low-noise amplifier as the first block of the receiver Front-End (FE) to reduce the Noise Figure (NF) of the overall system.

#### ***High Linearity***

WLAN systems are subject to co-channel interference and interference from strong co-existing cellular signals. High linearity characteristics such as Input 3<sup>rd</sup> Intercept Point (IIP3) and input compression point are required to improve an application's ability to distinguish between desired signals and spurious signals received close together.

Infineon offers a wide Radio Frequency (RF) product portfolio for Wi-Fi, including:

- Discrete transistors & Monolithic Microwave Integrated Circuit (MMIC) Low Noise Amplifiers (LNAs)
- Power detection diodes
- RF Complementary Metal-Oxide-Semiconductor (CMOS) and pin diode switches

For these kinds of high-data-rate wireless communication systems, it is essential to ensure the quality of the link path. Major performance criteria of this equipment must be met with regard to sensitivity, signal strength, and interference immunity with enough link budgets.

In addition, Infineon also offers RF Electro-Static Discharge (ESD) protection diodes. The ESD protection parts ESD106, ESD130/119, and ESD131/133 have a line capacitance value of as low as 0.1 pF and can protect the system from ESD strikes up to 10-25 kV contact discharge according to the IEC-61000-4-2 standard.

### 6.1.2 Dual-Band (2.4/5.0 GHz) WLAN (IEEE 802.11a/b/g/n) Front-End

Below are application examples of the dual-band (2.4/5.0 GHz) WLAN (IEEE 802.11a/b/g/n) FE.

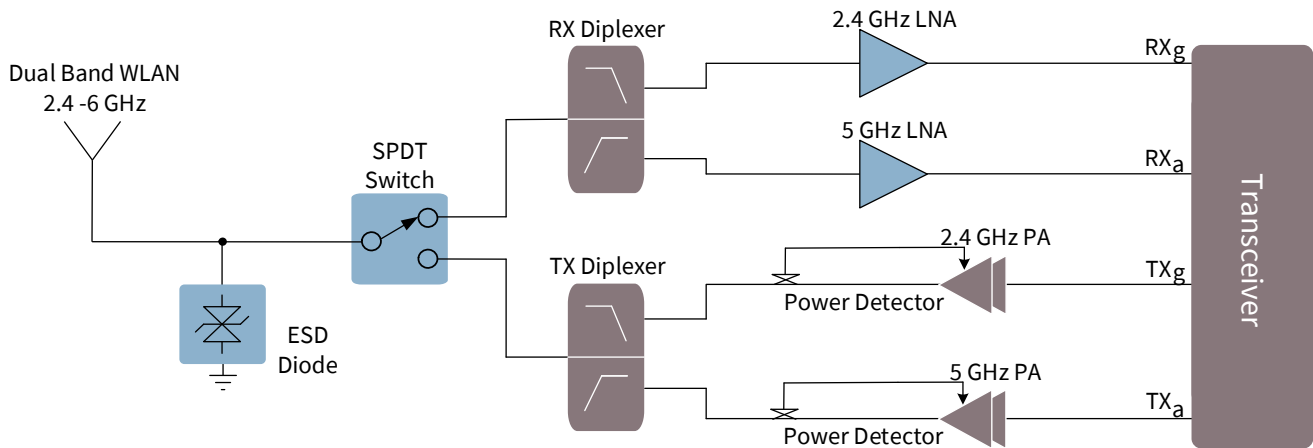

Figure 41 Dual-band (2.4/5.0 GHz) WLAN (IEEE 802.11a/b/g/n) FE

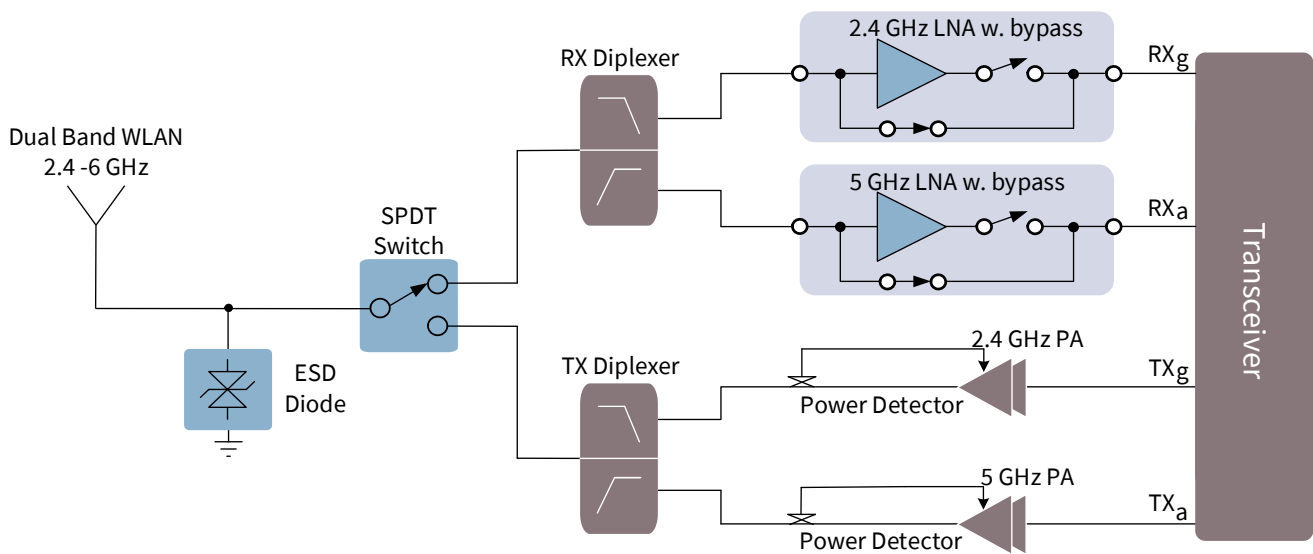
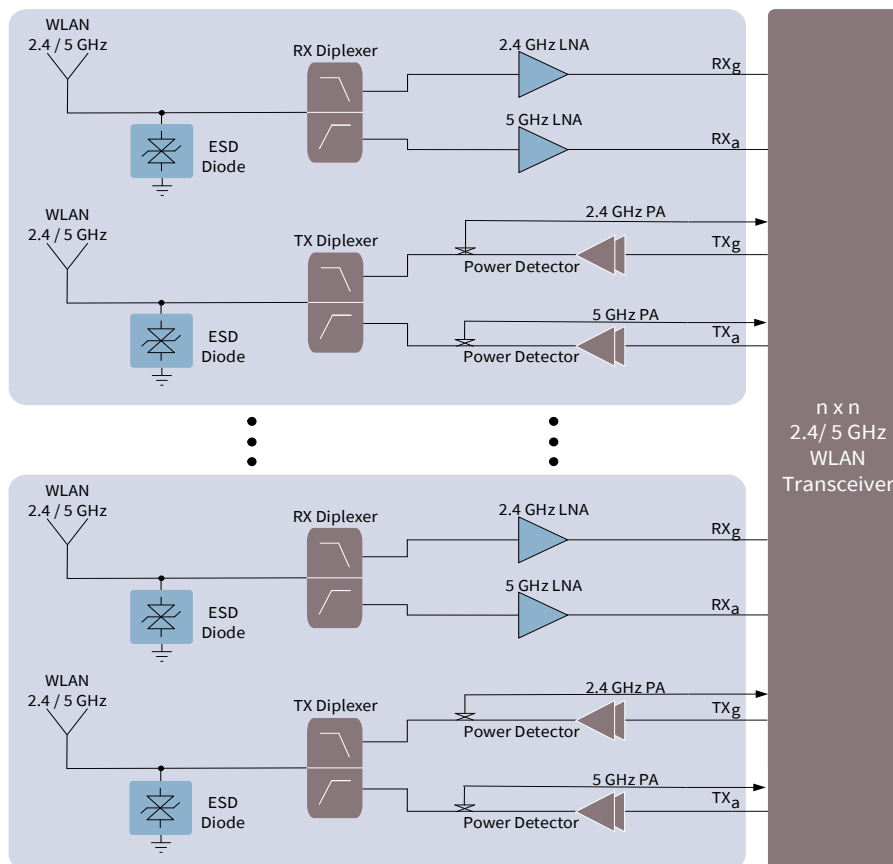

Figure 42 Dual-band (2.4/5.0 GHz) WLAN (IEEE 802.11a/b/g/n) FE with bypass LNAs

### 6.1.3 MIMO Configurations for WLAN (IEEE 802.11b/g/n & IEEE 802.11a/n/ac) Applications

IEEE 802.11n at 2.4 GHz and 5 GHz bands introduced the Multiple Input Multiple Output (MIMO) topologies in advanced high-data-rate WLAN applications. MIMO exploits multipath propagation known as space-division multiplexing. The transmitter IC multiplexes a data stream into multiple spatial streams, and transmits each spatial stream through separate antennas to corresponding antennas on the receiving end.

Doubling the number of spatial streams from one to two effectively doubles the data rate. However, increased power consumption due to the presence of multiple transmitter and receiver chains presents a major challenge. Infineon’s products offer very low power consumption, thus optimizing the battery life of the device. The following block diagram illustrates a dual-band WLAN MIMO FE. Please refer to the previous sections for the corresponding products for each function block.



**Figure 43 Dual-band (2.4/5.0 GHz) WLAN (IEEE 802.11b/g/n and 802.11a/n/ac N x N MIMO FE with dual-band antennas, dual-band TX and RX paths using dual-band LNAs**

## 6.1.4 WLAN (IEEE 802.11a/b/g/n) Front-End Devices

### RF MMIC LNAs

Product	Application Note	Gain [dB]	NF [dB]	IP <sub>-1dB</sub> [dBm]	IIP <sub>3</sub> [dBm]	Supply [V]	Current [mA]	Package
<b>2.4 GHz LNA</b>								
<a href="#">BGA7H1BN6</a>		12.3/-3.1	0.9/2.7	-1/+5	+5/+16	1.5...3.3	4.3/0.09	TSNP-6-2
<a href="#">BGA7H1N6</a>	<a href="#">AN365</a>	13.0	0.7	2	5	1.5...3.6	4.9	TSNP-6-2
<a href="#">BGB741L7ESD</a>	<a href="#">AN207</a> <sup>1)</sup> <a href="#">TR102</a> <sup>1)</sup>	17.5 18.7	1.5 1.1	-4.0 -6.7	-1.2 +2	3.0	10.0 10.8	TSLP-7-1
<a href="#">BFP740ESD</a>	<a href="#">AN295</a> <sup>1)</sup>	18.9	0.74	-12.9	-4.9	3	11.3	SOT343
<b>5 GHz LNA</b>								
<a href="#">BGB741L7ESD</a>	<a href="#">AN207</a> <sup>1)</sup>	12	2.0	-1	8.5	3.0	6	TSLP-7-1
<a href="#">BGB707L7ESD</a>	<a href="#">TR1012</a> <sup>1)</sup>	13.3	2.3	-6	-4.3	2.8	3.2	TSLP-7-1
<a href="#">BFP840FESD</a>	<a href="#">AN299</a> <sup>1)</sup>	18.4	1.1	-10	-1.2	3	15	TSFP-4-1

Notes: 1) On request; 2) Please visit [www.infineon.com/rf-mmhc](http://www.infineon.com/rf-mmhc) for alternative devices.

### RF CMOS Switches

Product	Type	App. Note	Supply [V]	V <sub>ctrl</sub> <sup>1)</sup> [V]	IL <sup>2)</sup> [dB]	Isolation [dB]	P <sub>0.1dB</sub> <sup>3)</sup> [dBm]	P <sub>in,max</sub> <sup>4)</sup> [dBm]	Ctrl. Int. <sup>5)</sup>	Package
<b>2.4 GHz Switches</b>										
<a href="#">BGS12AL7-4</a> <a href="#">BGS12AL7-6</a>	SPDT	<a href="#">AN175</a>	2.4...3.6	1.4...3.6	0.5	25	> 21	21	GPIO	TSLP-7-4 TSLP-7-6
<a href="#">BGS13S2N9</a>	SP3T	on request	1.8...3.3	1.35...V <sub>dd</sub>	0.33 / 0.35	30 / 27	>30	30	GPIO	TSNP-9-2
<b>2.4 GHz and 5 GHz Broadband Switches</b>										
<a href="#">BGS12SN6</a>	SPDT	<a href="#">AN332</a>	1.8...3.3	1.4...3.3	0.3/0.5 <sup>6)</sup>	32/30 <sup>6)</sup>	>30	30	GPIO	TSNP-6-2

Notes: 1) Digital Control Voltage; 2) IL = Insertion Loss; 3) 0.1 dB compression point; 4) Maximum input power; 5) Control Interface; 6) Value at 2.4 GHz/5 GHz; 7) Please visit [www.infineon.com/rfswitches](http://www.infineon.com/rfswitches) for alternative devices.

### RF Transistor LNAs for WLAN routers

Product	Application Note	Gain [dB]	NF [dB]	IP <sub>-1dB</sub> [dBm]	IIP <sub>3</sub> [dBm]	Supply [V]	Current [mA]	Package
<b>2.4 GHz LNA</b>								
<a href="#">BFP842ESD</a>	<a href="#">AN322</a> <sup>1)</sup>	19.3	0.8	-9.9	2.6	3.0	11.9	SOT343
<a href="#">BFR840L3RHESD</a>	<a href="#">AN339</a> <sup>1)</sup>	20.8	1.38	-18.6	-7.2	3.0	9.0	TSLP-3-9
<a href="#">BFR740L3RH</a>	<a href="#">AN173</a> <sup>1)</sup>	18.0	0.7	-10	+1	3.0	14.7	TSLP-3-9
<b>5 GHz LNA</b>								
<a href="#">BFR840L3RHESD</a>	<a href="#">AN281</a> <sup>1)</sup> <a href="#">AN290</a> <sup>1)</sup>	15.1	1.0	-8	+2	3.0	9.4	TSLP-3-9
<a href="#">BFR740L3RH</a>	<a href="#">AN170</a> <sup>1)</sup>	14.3	1.3	-5	+4	3.0	12.9	TSLP-3-9
<b>2.4 GHz &amp; 5 GHz Broadband LNA</b>								
<a href="#">BFR843EL3</a>	<a href="#">AN307</a> <sup>1)</sup>	18.5/13.3	1.0/1.3	-12.1/-7.5	-1.9/2.8	3.0	12.2	TSLP-3-9
<a href="#">BFR840L3RHESD</a>	<a href="#">AN292</a> <sup>1)</sup>	18.5/15	1.1/1.4	-15/-12.6	-5.5/0.3	3.0	9.4	TSLP-3-9

Note: 1) On request.

# Application Guide for Mobile Communication

## Wireless-LAN, Unlicensed LTE (LTE-U) and Licensed Assisted Access (LAA)



Please visit [www.infineon.com/lna\\_up\\_to\\_12\\_GHz](http://www.infineon.com/lna_up_to_12_GHz) for alternative devices.

### TVS Diodes for Antenna ESD Protection

Product	Application	$V_{RWM}$ [V]	ESD <sup>1)</sup> [kV]	$V_{CL}$ <sup>2)</sup> [V <sub>CL</sub> ]@[A]	$R_{dyn}$ <sup>3)</sup> [Ω]	$I_{PP}$ <sup>4)</sup> [A]	$V_{CL}$ <sup>5)</sup> [V]	$C_T$ <sup>6)</sup> [pF]	Protected Lines	Package
<a href="#">ESD106-B1-W0201</a>	med. P <sub>RF</sub>	±5.5	±12	±16@±8 ±25@±16	1.1	1.5	10	0.13	1	WLL-2-3
<a href="#">ESD119-B1-W01005</a> <a href="#">ESD130-B1-W0201</a>	med. P <sub>RF</sub> AN392	±5.5	±25	±20@±16 ±31@±30	0.8	1 2.5	11 14	0.3	1	WLL-2-2 WLL-2-1
<a href="#">ESD131-B1-W0201</a> <a href="#">ESD133-B1-W01005</a>	High-Speed Interfaces	±5.5	±20	±8.5@±8 ±13@±16	0.6 0.56	3	5.5	0.25 0.23	1	WLL-2-3 WLL-2-2

Notes: 1) Electrostatic discharge as per IEC61000-4-2, contact discharge; 2) TLP clamping voltage for 100 ns pulse length;  
 3) Dynamic resistance (ON-resistance) evaluated with TLP measurement (100 ns pulse length);  
 4) Maximum peak pulse current according to IEC61000-4-5 (8/20 μs); 5) Clamping Voltage at  $I_{PP,max}$  according to IEC61000-4-5 (8/20 μs);  
 6) Typical capacitance at 1 MHz (unless specified), 0 V, I/O vs. GND;  
 7) Please visit [www.infineon.com/protection/low-cap.esd-diodes](http://www.infineon.com/protection/low-cap.esd-diodes) for alternative devices.

## 6.2 Unlicensed LTE (LTE-U) and Licensed Assisted Access (LAA)

### 6.2.1 LTE-U and LAA as Data Rate Booster for LTE-A

Unlicensed Long-Term Evolution (LTE-U) and Licensed Assisted Access (LAA) are new concepts to increase the available RF bandwidth of mobile users to achieve much higher data rates than are possible with common LTE bands. For the Frequency-Division Duplexing (FDD) mode with the traditional LTE bands up to 2.7 GHz, intra- and inter-band carrier aggregation is used with up to 5 channels and a maximum 100 MHz bandwidth. However, this technology requires quite complex RF FE architecture, and suffers from performance degradation. On the other hand, LTE-U and LAA can make use of the 5- to 6-GHz ISM (Industrial, Science and Medicine) bands and can easily use much a much higher bandwidth (up to 160 MHz) with a simple RF FE. This additional available bandwidth can be combined with the common LTE bands at lower frequencies.

The figure 44 shows how these solutions work together with the LTE FDD operation by using carrier aggregation or link aggregation. The Figure 45 shows one of the first proposals by mobile phone makers in 3GPP for a 5-GHz LAA downlink to support common FDD up-/downlinks.

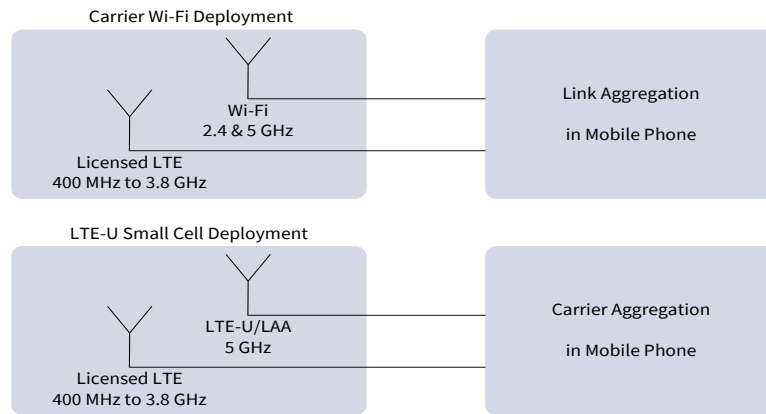

Figure 44 LTE FDD operation supported by LAA and LTE-U techniques using link aggregation or CA

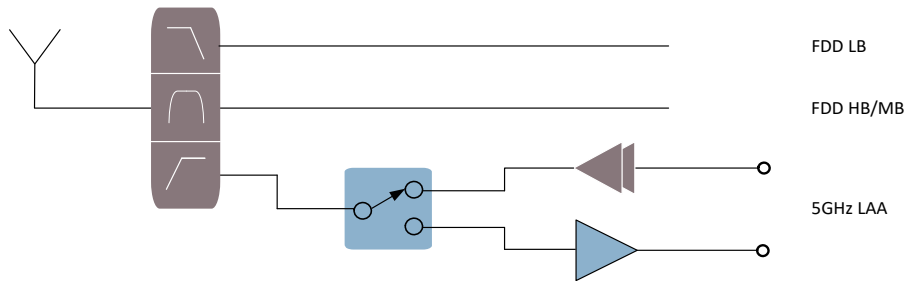

Figure 45 Block diagram of a 5-GHz LAA to support common FDD operation using CA

Nevertheless, this technology must comply with the WLAN IEEE802.11a/ac standard. Various implementations in the system are under investigation by 3<sup>rd</sup> Generation Partnership Project (3GPP) members to monitor and control the usage of the channels at 5 to 6 GHz to avoid link collision between WLAN and LTE-U or LAA. One method to avoid link collision is for a system to listen to a channel for at least 3 ms to make sure that it is free for use before the radio link is established and packages can be sent out. The LTE-U or LAA is going to be supported in coming generations of cellular modems.

## 6.2.2 LTE-U and LAA Front-End Devices

### RF MMIC LNAs

Product	Application Note	Gain [dB]	NF [dB]	IP <sub>-1dB</sub> [dBm]	IIP <sub>3</sub> [dBm]	Supply [V]	Current [mA]	Package
<a href="#">BGAU1A10</a> <sup>1)</sup>	on request	20.5/.../9.0/.../-6.5	1.7/.../1.6/.../6.5	-18/.../-6/.../tbd	-8/.../-2/.../+3	1.7...1.9	5.0/0.1	ATSLP-10-3
<a href="#">BGA8U1BN6</a>	on request	14.0/-5.0	1.6/5.0	-15/-5	-3/+11	1.6...3.1	4.0/0.2	TSNP-6-2
<a href="#">BGB741L7ESD</a>	<a href="#">AN207</a> <sup>1)</sup>	12	2.0	-1	8.5	3.0	6	TSLP-7-1
<a href="#">BGB707L7ESD</a>	<a href="#">TR1012</a> <sup>1)</sup>	13.3	2.3	-6	-4.3	2.8	3.2	TSLP-7-1

Notes: 1) On request; 2) Please visit [www.infineon.com/rf-mmhc](http://www.infineon.com/rf-mmhc) for alternative devices.

NEW!  
NEW!

# Application Guide for Mobile Communication

## Wireless-LAN, Unlicensed LTE (LTE-U) and Licensed Assisted Access (LAA)



### RF CMOS Switches

Product	Type	App. Note	Supply [V]	$V_{ctrl}^{(1)}$ [V]	$IL^{(2)}$ [dB]	Isolation [dB]	$P_{-0.1dB}^{(3)}$ [dBm]	$P_{in,max}^{(4)}$ [dBm]	Ctrl. Int. <sup>(5)</sup>	Package
<a href="#">BGS12SN6</a>	SPDT	<a href="#">AN332</a>	1.8...3.3	1.4...3.3	0.3/0.5 <sup>(6)</sup>	32/30 <sup>(6)</sup>	>30	30	GPIO	TSNP-6-2
<a href="#">BGS13GA14</a>	SP3T	on request	2.4...3.4	1.35...3.4	0.45/0.65 <sup>(6)</sup>	38/27 <sup>(6)</sup>	>28	28	GPIO	ATSLP-14
<a href="#">BGS14GA14</a>	SP4T	on request	2.4...3.4	1.35...3.4	0.45/0.65 <sup>(6)</sup>	38/27 <sup>(6)</sup>	>28	28	GPIO	ATSLP-14
<a href="#">BGS15GA14</a>	SP5T	on request	2.4...3.4	1.35...3.4	0.45/0.65 <sup>(6)</sup>	38/27 <sup>(6)</sup>	>28	28	GPIO	ATSLP-14

Notes: 1) Digital Control Voltage; 2)  $IL$  = Insertion Loss; 3) 0.1 dB compression point; 4) Maximum input power; 5) Control Interface; 6) Value at 2.4 GHz/5 GHz; 7) Please visit [www.infineon.com/rfswitches](http://www.infineon.com/rfswitches) for alternative devices.

### RF Schottky Diodes for Power Detectors

Product <sup>(1)</sup>	Application Note	$C_T^{(2)}$ [pF]	@ $V_R$ [V]	$V_F$ [mV]	@ $I_F$ [mA]	$V_F$ [mV]	@ $I_F$ [mA]	$I_R$ [μA]	@ $V_R$ [V]	Package
<a href="#">BAT62-02V</a>	<a href="#">AN185</a> <sup>(3)</sup>	0.35	0	580	2	-	-	< 10	40	SC79
<a href="#">BAT15-02EL</a> <a href="#">BAT15-02ELS</a>	on request	0.26	0	230	1	320	10	< 5	4	TSLP-2-19 TSSLP-2-3

Notes: 1) D = Dual; T = Triple; Q = Quadruple; 2) at 1 MHz; 3) On request; 4) Please visit [www.infineon.com/rf-mixer-detector-schottky-diodes](http://www.infineon.com/rf-mixer-detector-schottky-diodes) for alternative devices.

### RF Transistor LNAs

Product	Application Note	Gain [dB]	NF [dB]	$IP_{-1dB}$ [dBm]	$IIP_3$ [dBm]	Supply [V]	Current [mA]	Package
<a href="#">BFR840L3RHESD</a>	<a href="#">AN281</a> <sup>(1)</sup> <a href="#">AN290</a> <sup>(1)</sup>	15.1	1.0	-8	+2	3.0	9.4	TSLP-3-9
<a href="#">BFR740L3RH</a>	<a href="#">AN170</a> <sup>(1)</sup>	14.3	1.3	-5	+4	3.0	12.9	TSLP-3-9

Note: 1) On request. Please visit [www.infineon.com/lna\\_up\\_to\\_12\\_GHz](http://www.infineon.com/lna_up_to_12_GHz) for alternative devices.

### TVS Diodes for Antenna ESD Protection

Product	Application	$V_{RWM}$ [V]	ESD <sup>(1)</sup> [kV]	$V_{CL}^{(2)}$ [V <sub>CL</sub> ]@ [A]	$R_{dyn}^{(3)}$ [Ω]	$I_{PP}^{(4)}$ [A]	$V_{CL}^{(5)}$ [V]	$C_T^{(6)}$ [pF]	Protected Lines	Package
<a href="#">ESD106-B1-W0201</a>	med. P <sub>RF</sub>	±5.5	±12	±16@±8 ±25@±16	1.1	1.5	10	0.13	1	WLL-2-3
<a href="#">ESD119-B1-W01005</a> <a href="#">ESD130-B1-W0201</a>	med. P <sub>RF</sub> <a href="#">AN392</a>	±5.5	±25	±20@±16 ±31@±30	0.8	1 2.5	11 14	0.3	1	WLL-2-2 WLL-2-1
<a href="#">ESD131-B1-W0201</a> <a href="#">ESD133-B1-W01005</a>	High-Speed Interfaces	±5.5	±20	±8.5@±8 ±13@±16	0.6 0.56	3	5.5	0.25 0.23	1	WLL-2-3 WLL-2-2

Notes: 1) Electrostatic discharge as per IEC61000-4-2, contact discharge; 2) TLP clamping voltage for 100 ns pulse length; 3) Dynamic resistance (ON-resistance) evaluated with TLP measurement (100 ns pulse length); 4) Maximum peak pulse current according to IEC61000-4-5 (8/20 μs); 5) Clamping Voltage at  $I_{PP,max}$  according to IEC61000-4-5 (8/20 μs); 6) Typical capacitance at 1 MHz (unless specified), 0 V, I/O vs. GND; 7) Please visit [www.infineon.com/protection/low-cap.esd-diodes](http://www.infineon.com/protection/low-cap.esd-diodes) for alternative devices.

## 7 FM Radio and Mobile TV

### 7.1 FM Radio with Embedded Antenna

Frequency Modulation (FM) radio function is embedded in many mobile phones. This function is especially useful during disaster relief situations, where FM radio service sometimes remains active despite damage to the conditions of the cellular infrastructures.

One possibility for FM radio reception is using a headset cable as an antenna for reception. If FM radio is to be used without the headset cable, the antenna has to be integrated inside the phone. The major FM topologies widely used in the market are:

- FM Receiver (RX) only (Application a): Only the FM radio receive function is implemented
- FM Transmitter (TX) and RX (Application b): The FM path is used for both FM radio reception and FM signal transmission, streaming music from the mobile phone to other FM receivers such as car radio and home hi-fi systems

Infineon’s Low Noise Amplifiers (LNAs) solutions solve the problem of the short FM antenna in mobile phones through better impedance matching between the FM antenna and the FM receiver. Therefore, they help to enable a high signal-to-noise ratio without the use of a headset. BGA729N6 is a pre-matched 50-ohm solution for FM application and mobile TV applications; it requires only 2 external components. BGB707L7ESD is a general purpose LNA with high ohmic input impedance, offering the flexibility to match various antenna and receiver input impedances.

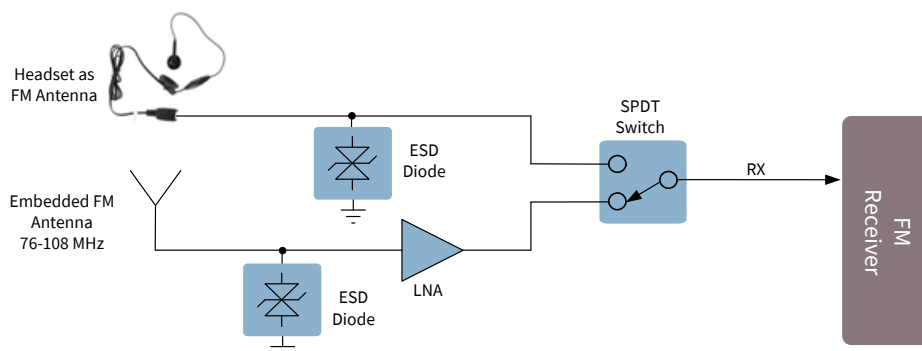

**Figure 46 Application a: FM reception only**

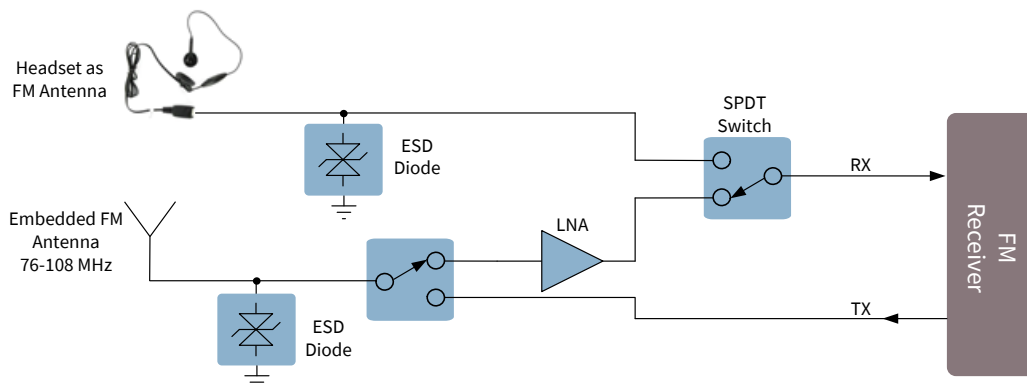

**Figure 47 Application b: FM transmit/receive function block**

### RF MMIC LNAs

Product	Application Note	Gain <sup>4)</sup> [dB]	NF <sup>4)</sup> [dB]	IP <sub>-1dB</sub> <sup>4)</sup> [dBm]	IIP <sub>3</sub> <sup>4)</sup> [dBm]	Supply [V]	Current <sup>4)</sup> [mA]	Package
<a href="#">BGA729N6</a>	<a href="#">AN441</a> <sup>2)</sup> <a href="#">AN505</a> <sup>2)</sup>	17.0/-6	1.1/4.3	-15/+5	-6/+17	1.5...3.3	6.5/0.5	TSNP-6-2
<a href="#">BGB707L7ESD</a>	<a href="#">AN177</a> <sup>6)</sup> <a href="#">AN181</a> <sup>6)</sup>	12.0 15.0	1.0 1.3	-5 -10	-12 -6	3.0 2.8	3.0 4.2	TSLP-7-1

Notes: 1) For high-ohmic antenna; 2) For 50-Ω antenna; 3) LNA with two gain modes (high-gain/low-gain); 4) Values in high-gain (HG) / low-gain (LG) mode; 5) Please visit [www.infineon.com/itelna](http://www.infineon.com/itelna) for alternative devices. 6) On request.

### RF CMOS Switches

Product	Type	App. Note	Supply [V]	V <sub>ctrl</sub> <sup>1)</sup> [V]	IL <sup>2)</sup> [dB]	Isolation [dB]	P <sub>-0.1dB</sub> <sup>3)</sup> [dBm]	P <sub>in,max</sub> <sup>4)</sup> [dBm]	Ctrl. Int. <sup>5)</sup>	Package
<a href="#">BGS12AL7-4</a> <a href="#">BGS12AL7-6</a>	SPDT	<a href="#">AN175</a>	2.4...3.6	1.4...3.6	0.3	50	> 21	21	GPIO	TSLP-7-4 TSLP-7-6
<a href="#">BGS12SN6</a>	SPDT	<a href="#">AN332</a>	1.8...3.3	1.4...3.3	0.2	40	>30	30	GPIO	TSNP-6-2

Notes: 1) Digital Control Voltage; 2) IL = Insertion Loss; 3) 0.1 dB compression point; 4) Maximum input power; 5) Control Interface; 6) Please visit [www.infineon.com/rfswitches](http://www.infineon.com/rfswitches) for alternative devices.

### TVS Diodes for Antenna ESD Protection

Product	Application	V <sub>RWM</sub> [V]	ESD <sup>1)</sup> [kV]	V <sub>CL</sub> <sup>2)</sup> [V <sub>CL</sub> ]@ [A]	R <sub>dyn</sub> <sup>3)</sup> [Ω]	I <sub>PP</sub> <sup>4)</sup> [A]	V <sub>CL</sub> <sup>5)</sup> [V]	C <sub>T</sub> <sup>6)</sup> [pF]	Protected Lines	Package
<a href="#">ESD106-B1-W0201</a>	med. P <sub>RF</sub>	±5.5	±12	±16@±8 ±25@±16	1.1	1.5	10	0.13	1	WLL-2-3
<a href="#">ESD119-B1-W01005</a> <a href="#">ESD130-B1-W0201</a>	med. P <sub>RF</sub> <a href="#">AN392</a>	±5.5	±25	±20@±16 ±31@±30	0.8	1 2.5	11 14	0.3	1	WLL-2-2 WLL-2-1
<a href="#">ESD131-B1-W0201</a> <a href="#">ESD133-B1-W01005</a>	High-Speed Interfaces	±5.5	±20	±8.5@±8 ±13@±16	0.6 0.56	3	5.5	0.25 0.23	1	WLL-2-3 WLL-2-2

Notes: 1) Electrostatic discharge as per IEC61000-4-2, contact discharge; 2) TLP clamping voltage for 100 ns pulse length; 3) Dynamic resistance (ON-resistance) evaluated with TLP measurement (100 ns pulse length); 4) Maximum peak pulse current according to IEC61000-4-5 (8/20 μs); 5) Clamping Voltage at I<sub>PP,max</sub> according to IEC61000-4-5 (8/20 μs); 6) Typical capacitance at 1 MHz (unless specified), 0 V, I/O vs. GND; 7) Please visit [www.infineon.com/protection/low-cap.esd-diodes](http://www.infineon.com/protection/low-cap.esd-diodes) for alternative devices.

### 7.2 TV Reception in Mobile Phones

Mobile phones today have not only wireless functions for voice and data but also entertainment features. Mobile TV is one of the most fascinating features. It brings live news and entertainment programs onto the phone display and enables people not to miss their favorite programs. Product portfolios for mobile TV applications are described in Figure 48.

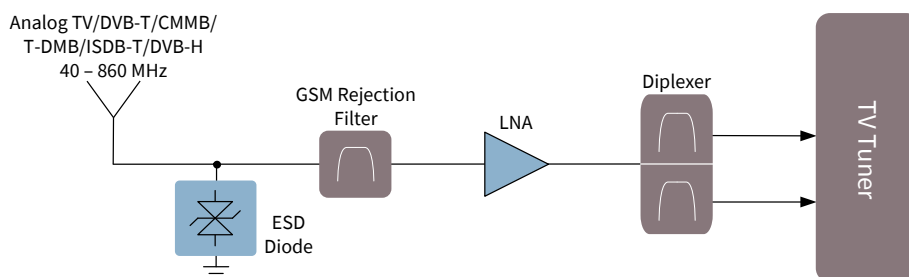

**Figure 48 Block diagram of a Mobile TV RF FE**

#### RF MMIC LNAs

Product	Application Note	Gain <sup>4)</sup> [dB]	NF <sup>4)</sup> [dB]	IP <sub>-1dB</sub> <sup>4)</sup> [dBm]	IIP <sub>3</sub> <sup>4)</sup> [dBm]	Supply [V]	Current <sup>4)</sup> [mA]	Package
<a href="#">BGA729N6</a>	<a href="#">AN441</a> <sup>2)</sup> <a href="#">AN505</a> <sup>2)</sup>	16.3/-4	1.1/4.3	-15/+5	-6/+17	1.5...3.3	6.0/0.5	TSNP-6-2
<a href="#">BGB707L7ESD</a>	<a href="#">AN232</a> <sup>6)</sup>	13.0	1.5	-7	-11	3.0	2.9	TSLP-7-1

Notes: 1) For high-ohmic antenna; 2) For 50-Ω antenna;  
 3) LNA with two gain modes (high-gain/low-gain); 4) Values in high-gain (HG) / low-gain (LG) mode;  
 5) Please visit [www.infineon.com/ltelna](http://www.infineon.com/ltelna) for alternative devices. 6) On request.

#### RF CMOS Switches

Product	Type	App. Note	Supply [V]	V <sub>ctrl</sub> <sup>1)</sup> [V]	IL <sup>2)</sup> [dB]	Isolation [dB]	P <sub>-0.1dB</sub> <sup>3)</sup> [dBm]	P <sub>in,max</sub> <sup>4)</sup> [dBm]	Ctrl. <sup>5)</sup> Int.	Package
<a href="#">BGS12AL7-4</a> <a href="#">BGS12AL7-6</a>	SPDT	<a href="#">AN175</a>	2.4...3.6	1.4...2.8	0.35	> 32	> 21	21	GPIO	TSLP-7-4 TSLP-7-6
<a href="#">BGS12SN6</a>	SPDT	<a href="#">AN332</a>	1.8...3.3	1.35...3.3	0.25	> 40	>30	30	GPIO	TSNP-6-2

Notes: 1) Digital Control Voltage; 2) IL = Insertion Loss;  
 3) 0.1 dB compression point; 4) Maximum input power;  
 5) Control Interface 6) Please visit [www.infineon.com/rfswitches](http://www.infineon.com/rfswitches) for alternative devices.

#### TVS Diodes for Antenna ESD Protection

Product	Application	V <sub>RWM</sub> [V]	ESD <sup>1)</sup> [kV]	V <sub>CL</sub> <sup>2)</sup> [V <sub>CL</sub> ]@ [A]	R <sub>dyn</sub> <sup>3)</sup> [Ω]	I <sub>PP</sub> <sup>4)</sup> [A]	V <sub>CL</sub> <sup>5)</sup> [V]	C <sub>T</sub> <sup>6)</sup> [pF]	Protected Lines	Package
<a href="#">ESD106-B1-W0201</a>	med. P <sub>RF</sub>	±5.5	±12	±16@±8 ±25@±16	1.1	1.5	10	0.13	1	WLL-2-3
<a href="#">ESD119-B1-W01005</a> <a href="#">ESD130-B1-W0201</a>	med. P <sub>RF</sub> <a href="#">AN392</a>	±5.5	±25	±20@±16 ±31@±30	0.8	1 2.5	11 14	0.3	1	WLL-2-2 WLL-2-1
<a href="#">ESD131-B1-W0201</a> <a href="#">ESD133-B1-W01005</a>	High-Speed Interfaces	±5.5	±20	±8.5@±8 ±13@±16	0.6 0.56	3	5.5	0.25 0.23	1	WLL-2-3 WLL-2-2

Notes: 1) Electrostatic discharge as per IEC61000-4-2, contact discharge; 2) TLP clamping voltage for 100 ns pulse length;  
 3) Dynamic resistance (ON-resistance) evaluated with TLP measurement (100 ns pulse length);  
 4) Maximum peak pulse current according to IEC61000-4-5 (8/20 μs); 5) Clamping Voltage at I<sub>PP,max</sub> according to IEC61000-4-5 (8/20 μs);  
 6) Typical capacitance at 1 MHz (unless specified), 0 V, I/O vs. GND;  
 7) Please visit [www.infineon.com/protection/low-cap.esd-diodes](http://www.infineon.com/protection/low-cap.esd-diodes) for alternative devices.

### 7.3 FM and TV Reception in Mobile Phones with Band Selection Switch

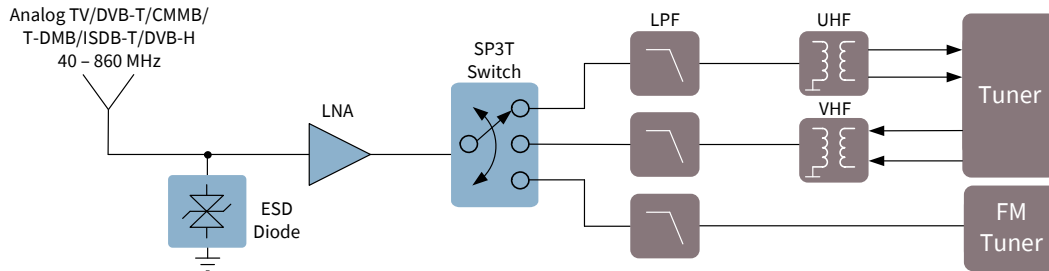

**Figure 49** Block diagram of a FM/Mobile TV RF FE with band selection switch

#### RF MMIC LNAs

Product	Application Note	Gain <sup>(4)</sup> [dB]	NF <sup>(4)</sup> [dB]	IP <sub>-1dB</sub> <sup>(4)</sup> [dBm]	IIP <sub>3</sub> <sup>(4)</sup> [dBm]	Supply [V]	Current <sup>(4)</sup> [mA]	Package
<a href="#">BGA729N6</a>	<a href="#">AN441</a> <sup>(2)</sup> <a href="#">AN505</a> <sup>(2)</sup>	16.3/-4	1.1/4.3	-15/+5	-6/+17	1.5...3.3	6.5/0.5	TSNP-6-2
<a href="#">BGB707L7ESD</a>	<a href="#">AN232</a> <sup>(6)</sup>	13.0	1.5	-7	-11	3.0	2.9	TSLP-7-1

Notes: 1) For high-ohmic antenna; 2) For 50-Ω antenna;  
 3) LNA with two gain modes (high-gain/low-gain); 4) Values in high-gain (HG) / low-gain (LG) mode;  
 5) Please visit [www.infineon.com/itelna](http://www.infineon.com/itelna) for alternative devices; 6) On request.

#### RF CMOS Switches

Product	Type	App. Note	Supply [V]	V <sub>ctrl</sub> <sup>(1)</sup> [V]	IL <sup>(2)</sup> [dB]	Isolation [dB]	P <sub>-0.1dB</sub> <sup>(3)</sup> [dBm]	P <sub>in,max</sub> <sup>(4)</sup> [dBm]	Ctrl. <sup>(5)</sup> Int.	Package
<a href="#">BGS13SN9</a>	SP3T	on request	1.8...3.3	1.35...V <sub>dd</sub>	0.33 / 0.35	30 / 27	>30	30	GPIO	TSNP-9-2

Notes: 1) Digital Control Voltage; 2) IL = Insertion Loss;  
 3) 0.1 dB compression point; 4) Maximum input power;  
 5) Control Interface 6) Please visit [www.infineon.com/rfswitches](http://www.infineon.com/rfswitches) for alternative devices.

#### TVS Diodes for Antenna ESD Protection

Product	Application	V <sub>RWM</sub> [V]	ESD <sup>(1)</sup> [kV]	V <sub>CL</sub> <sup>(2)</sup> [V <sub>CL</sub> ]@ [A]	R <sub>dyn</sub> <sup>(3)</sup> [Ω]	I <sub>PP</sub> <sup>(4)</sup> [A]	V <sub>CL</sub> <sup>(5)</sup> [V]	C <sub>T</sub> <sup>(6)</sup> [pF]	Protected Lines	Package
<a href="#">ESD106-B1-W0201</a>	med. P <sub>RF</sub>	±5.5	±12	±16@±8 ±25@±16	1.1	1.5	10	0.13	1	WLL-2-3
<a href="#">ESD119-B1-W01005</a> <a href="#">ESD130-B1-W0201</a>	med. P <sub>RF</sub> <a href="#">AN392</a>	±5.5	±25	±20@±16 ±31@±30	0.8	1 2.5	11 14	0.3	1	WLL-2-2 WLL-2-1
<a href="#">ESD131-B1-W0201</a> <a href="#">ESD133-B1-W01005</a>	High-Speed Interfaces	±5.5	±20	±8.5@±8 ±13@±16	0.6 0.56	3	5.5	0.25 0.23	1	WLL-2-3 WLL-2-2

Notes: 1) Electrostatic discharge as per IEC61000-4-2, contact discharge; 2) TLP clamping voltage for 100 ns pulse length;  
 3) Dynamic resistance (ON-resistance) evaluated with TLP measurement (100 ns pulse length);  
 4) Maximum peak pulse current according to IEC61000-4-5 (8/20 μs); 5) Clamping Voltage at I<sub>PP,max</sub> according to IEC61000-4-5 (8/20 μs);  
 6) Typical capacitance at 1 MHz (unless specified), 0 V, I/O vs. GND;  
 7) Please visit [www.infineon.com/protection/low-cap.esd-diodes](http://www.infineon.com/protection/low-cap.esd-diodes) for alternative devices.

## 8 Interface protection against ESD/Surge

### 8.1 ESD Protection

Faster, smaller and smarter electronics creates profitability by enabling new and better applications. The race to pack more and more high-speed functions in a smaller space accelerates miniaturization roadmaps. However, downscaling the size of semiconductor chips together with increasing their doping levels dramatically reduces the thin gate oxide layer and the width of the pn-junction in semiconductor chips. These factors, in combination with greater circuit population, increase the susceptibility of the chips to damage from Electro-Static Discharge (ESD).

Resulting failure modes of electronic equipment include hard failures, latent damage, or temporary malfunctions. Hard failures are easier to spot, and in general require the failed device to be replaced. In the best case, the failure will be detected before the equipment leaves the factory and customers will never receive it. Failures leading to temporary malfunctions of equipment or latent failures are quite common and very difficult to detect or trace in the field. Temporary malfunctions may go unreported but can result in negative customer impressions as the user may need to reset the equipment. A product recall for swapping or repairing parts due to ESD failures may cost the company several times more than the cost of the device itself.

The only way to ensure stable operation and maximum reliability at the system level is to ensure that equipment is properly protected from electrostatic discharge and transients by dedicated protection device.

#### Infineon's Value Proposition

Infineon ESD protection devices improve ESD immunity at the system level by providing first-class protection beyond the IEC61000-4-2 level-4 standard, and offer:

- Superior multi-strike absorption capability
- Safe and stable clamping voltages to protect even the most sensitive electronic equipment
- Full compliance with high-speed signal quality requirements
- Efficient PCB space usage thanks to small 0201 and 01005 package dimensions
- Extremely low leakage currents to extend battery life

For detailed information about our ESD protection diode portfolio and applications please visit our website:

[www.infineon.com/protection](http://www.infineon.com/protection).

Below is an overview of the available ESD protection devices for various interfaces of mobile devices.

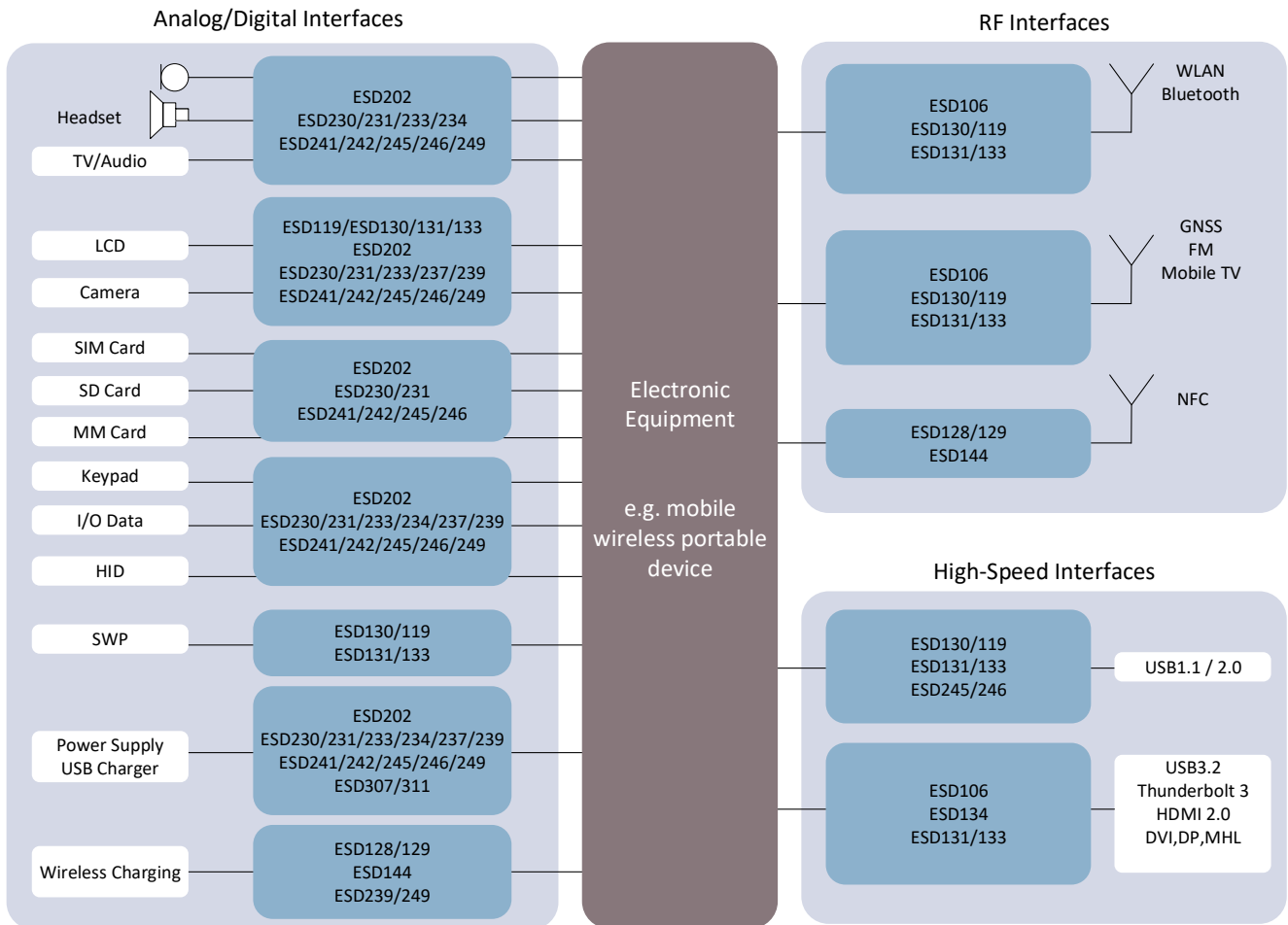

**Figure 50 Interface protection with discrete ESD protection**

In a modern mobile phone there are a lot of open access points such as a charging port, audio ports (line out, headset jack), and data interfaces (USB) that could permit ESD strikes to reach the inner PCB.

Other very risky paths for ESD strikes are the case bottom, and air gaps in the enclosure or the microphone/speaker. Often the point of entrance for an ESD strike is not obvious.

To provide proper ESD protection for the inner PCB, it is mandatory to place fast-responding TVS protection diodes at specific locations. General-purpose TVS diodes can be used; depending on the position to be protected (e.g. where the signal frequency is low and therefore device capacitance does not matter). They are listed in the table in below page.

Dedicated low-capacitance TVS diodes must be used for high-speed data lines to avoid any impact on signal integrity. The higher the data rate, the more the device capacitance matters. For the 5 Gb/s USB3.0 data rate the ESD protection device capacitance should be below 0.5pF. Please refer to the table “TVS ESD Diodes for high-speed digital interface” regarding these low-capacitance TVS diodes.

### ESD Protection Diodes for General-Purpose Interfaces

Product	Application	$V_{RWM}$ [V]	ESD <sup>1)</sup> [kV]	$V_{CL}^{2)}$ [V <sub>CL</sub> ]@[A]	$R_{dyn}^{3)}$ [Ω]	$I_{PP}^{4)}$ [A]	$V_{CL}^{5)}$ [V]	$C_T^{6)}$ [pF]	Protected Lines	Package
<a href="#">ESD202-B1-W01005</a>	General purpose	±5.5	±16	±13@±16 ±15@±16	0.2	3	12	6.5	1	WLL-2-2
<a href="#">ESD230-B1-W0201</a>	Gen. purpose	±5.5	±15	±13@±16	0.22	3	14	7	1	WLL-2-1
<a href="#">ESD231-B1-W0201</a>	General purpose	±5.5	±30	±12@±16 ±16@±30	0.3	2 9	8 10	3.5	1	WLL-2-1
<a href="#">ESD233-B1-W0201</a>	Gen. purpose	±5.5	±20	±13@±16	0.2	3	12.5	33	1	WLL-2-1
<a href="#">ESD234-B1-W0201</a>	Gen. purpose	±5.5	±20	±13@±16	0.2	3	12.5	56	1	WLL-2-1
<a href="#">ESD237-B1-W0201</a>	General purpose	±8	±16	±13@±16 ±17@±30	0.21	3	12	7	1	WLL-2-1
<a href="#">ESD239-B1-W0201</a>	Gen. purpose	±22	±16	±27@±16	0.27	3		3.2	1	WLL-2-3
<a href="#">ESD241-B1-W0201</a> <a href="#">ESD242-B1-W01005</a>	General purpose	±3.3	±15	±6@±16	0.1	4		6.5 6	1	WLL-2-3 WLL-2-2
<a href="#">ESD245-B1-W0201</a> <a href="#">ESD246-B1-W01005</a>	General purpose	±5.5	±15	±7.5@±16	0.1	5		5.8 5.5	1	WLL-2-3 WLL-2-2
<a href="#">ESD249-B1-W0201</a>	Gen. purpose	±18	±16	±23@±16	0.27	3		4.2	1	WLL-2-3

Notes: 1) Electrostatic discharge as per IEC61000-4-2, contact discharge; 2) TLP clamping voltage for 100 ns pulse length;  
3) Dynamic resistance (ON-resistance) evaluated with TLP measurement (100 ns pulse length);  
4) Maximum peak pulse current according to IEC61000-4-5 (8/20 μs); 5) Clamping Voltage at  $I_{PP,max}$  according to IEC61000-4-5 (8/20 μs);  
6) Typical capacitance at 1 MHz (unless specified), 0 V, I/O vs. GND;  
7) Please visit [www.infineon.com/protection/low-cap.esd-diodes](http://www.infineon.com/protection/low-cap.esd-diodes) for alternative devices.

### ESD Protection Diodes for High Speed Interfaces

Product	Application	$V_{RWM}$ [V]	ESD <sup>1)</sup> [kV]	$V_{CL}^{2)}$ [V <sub>CL</sub> ]@[A]	$R_{dyn}^{3)}$ [Ω]	$I_{PP}^{4)}$ [A]	$V_{CL}^{5)}$ [V]	$C_T^{6)}$ [pF]	Protected Lines	Package
<a href="#">ESD119-B1-W01005</a> <a href="#">ESD130-B1-W0201</a>	med. P <sub>RF</sub> <a href="#">AN392</a>	±5.5	±25	±20@±16 ±31@±30	0.8	1 2.5	11 14	0.3	1	WLL-2-2 WLL-2-1
<a href="#">ESD128-B1-W0201</a> <a href="#">ESD129-B1-W01005</a>	NFC-RF <a href="#">AN244</a>	±18	±15	±32@16	0.85	1	18.5	0.3 0.25	1	WLL-2-1 WLL-2-2
<a href="#">ESD131-B1-W0201</a> <a href="#">ESD133-B1-W01005</a>	High-Speed Interfaces	±5.5	±20	±8.5@±8 ±13@±16	0.6 0.56	3	5.5	0.25 0.23	1	WLL-2-3 WLL-2-2
<a href="#">ESD144-B1-W0201</a>	NFC-RF	±18	±15	±13@±16	0.6	2		0.25	1	WLL-2-3
<a href="#">ESD5V5U5ULC</a>	USB2.0-HS, V <sub>CC</sub>	+5.5	±25	8.9@16 11.5@30	0.2	6	10	0.45	4	SC74

Notes: 1) Electrostatic discharge as per IEC61000-4-2, contact discharge; 2) TLP clamping voltage for 100 ns pulse length;  
3) Dynamic resistance (ON-resistance) evaluated with TLP measurement (100 ns pulse length); 4) Maximum peak pulse current according to IEC61000-4-5 (8/20 μs);  
5) Clamping Voltage at  $I_{PP,max}$  according to IEC61000-4-5 (8/20 μs);  
6) Typical capacitance at 1 MHz (unless specified), 0 V, I/O vs. GND;  
7) Please visit our webpage [www.infineon.com/protection/low-cap.esd-diodes](http://www.infineon.com/protection/low-cap.esd-diodes) for alternative devices

## 8.2 Surge Protection for the Battery Charger Port

To protect a mobile device from overvoltage at the battery port, an Over-Voltage Protection (OVP) is designed in. This functionality can be located inside the PMU (Power Management Unit) or in a dedicated IC in front the battery charger (BC) and the PMUs. The job of the OVP is to control the path between the external charger interface and BC / PMUs. In case of an undesired high voltage the link is switched off. The maximum protection voltage of the OVP is restricted to 20 to 40V depending on the IC technology. Higher voltage will destroy the OVP.

A certain countermeasure is required to handle higher voltage peaks such as ESD or surge events, injected directly into the charger interface pins. Another threat is glitches coming from the power main and bypassing the wall plug charger unit, or start up glitches generated in the wall plug charger itself. These high-energy single events have to be shunted to GND in the mobile device by a surge robust TVS diode in front of the OVP without exceeding the maximum voltage of the OVP.

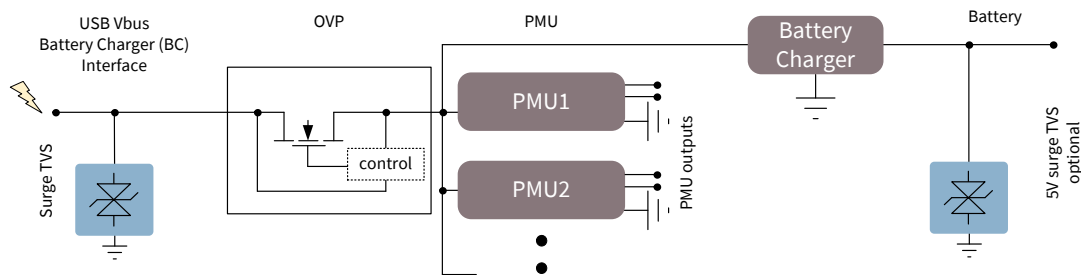

Figure 51 Mobile device charging interface (Quick Charge, USB-PD)

### Surge TVS Diodes

Product	Application	$V_{RWM}$ [V]	ESD <sup>1)</sup> [kV]	$V_{CL}$ <sup>2)</sup> [V <sub>CL</sub> ]@[A]	$R_{dyn}$ <sup>3)</sup> [Ω]	$I_{PP}$ <sup>4)</sup> [A]	$V_{CL}$ <sup>5)</sup> [V]	$C_T$ <sup>6)</sup> [pF]	Protected Lines	Package
<a href="#">ESD307-U1-02N</a>	ESD/Surge <a href="#">AN372</a>	10	±30	17@±16 18@±30	0.05	1 34	16 24	270	1	TSNP-2-2
<a href="#">ESD311-U1-02N</a>	ESD/Surge <a href="#">AN372</a>	15	±30	22@±16 23@±30	0.07	1 28	21 29	210	1	TSNP-2-2

Notes: 1) Electrostatic discharge as per IEC61000-4-2, contact discharge; 2) TLP clamping voltage for 100 ns pulse length;  
3) Dynamic resistance (ON-resistance) evaluated with TLP measurement (100 ns pulse length);  
4) Maximum peak pulse current according to IEC61000-4-5 (8/20 μs); 5) Clamping Voltage at  $I_{PP,max}$  according to IEC61000-4-5 (8/20 μs);  
6) Typical capacitance at 1 MHz (unless specified), 0 V, I/O vs. GND;

## Abbreviations

Abbr.	Terms
ATSLP	Advanced Thin Small Leadless Package
ASM	Antenna Switch Module
BAW	Bulk Acoustic Wave
BDS	Beidou Navigation System
CA	Carrier Aggregation
CDMA	Code Division Multiple Access
CMOS	Complementary Metal-Oxide-Semiconductor
CSP	Chip Scale Package
DC	Direct Current
DCS	Digital Cellular Service
DDA	Dual Diversity Antenna
DL	Downlink
DPDT	Double Pole Double Throw
DP	Display Port
DSSS	Direct Sequence Spread Spectrum
DVI	Digital Visual Interface
ECU	Electronic Control Unit
EDGE	Enhanced Data Rates for GSM Evolution
EM	Electro-Magnetic
EMI	Electromagnetic Interference
ESD	Electro-Static Discharge
E-UTRA	Evolved Universal Terrestrial Radio Access
FDD	Frequency-Division Duplexing
FEM	Front-End Module
FHSS	Frequency-Hopping Spread Spectrum
FM	Frequency Modulation
GLONASS	Global Orbiting Navigation Satellite System
GNSS	Global Navigation Satellite System
GPIO	General Purpose Input/Output
GPS	Global Positioning System
GSM	Global System for Mobile Communication
HBM	Human Body Model
HDMI	High-Definition Multimedia Interface
HSPA	High-Speed Packet Access
HSPA+	Evolved High-Speed Packet Access
IC	integrated circuit
IL	Insertion Loss
IMD	Intermodulation Distortion
IPD	Integrated Passive Device
IMT	International Mobile Telecommunications
ISM	Industrial, Scientific and Medical
LNA	Low Noise Amplifier
LMM	LNA multiplexer modules
LTE	Long-Term Evolution
LTE-A	LTE-Advanced
MHL	Mobile High-Definition Link
MIPI	Mobile Industry Processor Interface
MIPI RFFE	Mobile Industry Processor Interface for RF Front-End Devices
MMIC	Monolithic Microwave Integrated Circuit
MIMO	Multiple Input Multiple Output

Abbr.	Terms
MU	Multi-User
NF	Noise Figure
NFC	Near-Field Communication
OFDM	Orthogonal Frequency Division Multiplexing
PCS	Personal Communications Services
PCB	Printed Circuit Board
PDA	Personal Digital Assistant
PIFA	Planar Inverted F antenna
PIN-Diode	Positive-Intrinsic-Negative diode
PND	Personal Navigation Devices
QAM	Quadrature Amplitude Modulation
RF	Radio Frequency
RF FE	RF Front-End
RFID	radio-frequency identification
RFS	RF and Sensors
RoHS	Restriction of Hazardous Substances
RPP	Reverse Polarity Protection
RX	Receiver
SAR	Search and Rescue
SAW	Surface Acoustic Wave
SD	Secure Digital Card
SI	Signal Integrity
SIM	Subscriber Identity Module
SPI	Serial Peripheral Interface
SPxT	Single Pole x Throw (Switch)
SV-LTE	Simultaneous Voice and LTE
TDD	Time-division duplexing
TD-SCDMA	Time Division-Synchronous Code Division Multiple Access
TD-LTE	Time Division Long-Term Evolution
T(S)SLP	Thin (Super) Small Leadless Package
TRP	Total Radiated Power
TSNP	Thin Small Non Leaded Package
TTF	Time to First fix
TT	Truth Table
TVS	Transient Voltage Suppression
TX	Transmitter
UE	User Equipment
UHS-I	Ultra High Speed SD card in Version 3.01
UMTS	Universal Mobile Telecommunications System
UL	Uplink
USB	Universal Serial Bus
VoIP	Voice over IP
W-CDMA	Wideband-Code Division Multiple Access
WLAN	Wireless Local Area Network
μSD	Micro Secure Digital Memory
3GPP	3rd Generation Partnership Project

## Alphanumerical List of Symbols

Symbol	Term	Unit
$C_T$	Total Diode capacitance	[pF]
ESD	Voltage of ESD pulse	[kV]
$I_F$	Forward current	[mA]
$I_R$	Reverse current	[ $\mu$ A]
$I_{PP}$	Maximum peak pulse current	[A]
$IIP_3$	Input 3 <sup>rd</sup> intercept point	[dBm]
IL	Insertion loss	[dB]
IMD2	2 <sup>nd</sup> order intermodulation distortion	[dBm]
$IP_{-1dB}$	Input 1dB compression point	[dBm]
LDO	Low drop out	[V]
NF	Noise figure	[dB]
$OIP_3$	Output 3 <sup>rd</sup> intercept point	[dBm]
$OP_{-1dB}$	Output 1dB compression point	[dBm]
$P_{-0.1dB}$	0.1dB compression point	[dBm]
$P_{in,max}$	Maximum input power	[dBm]
$R_{dyn}$	Dynamic resistance	[ $\Omega$ ]
$r_F$	Differential forward resistance	[ $\Omega$ ]
$V_{CL}$	Clamping voltage	[V]
$V_{ctrl}$	Digital control voltage	[V]
$V_{dd}$	DC supply voltage	[V]
$V_F$	Forward voltage	[mV]
$V_R$	Reverse voltage	[V]
$V_{RWM}$	Reverse working voltage	[V]
$\tau_L$	Storage time	[ns]











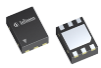



### Package Information

Package (JEITA-code)	
X	L × W × H
	PIN-Count
	Scale 1:1
All Dimensions in mm	

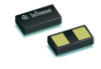
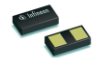

All products are available in green (RoHS compliant)

<table border="1"> <tr><th colspan="2">ATSLP-12-1 (-)</th></tr> <tr><td>13</td><td>1.9 × 1.1 × 0.65</td></tr> <tr><td></td><td>3:1</td></tr> </table>	ATSLP-12-1 (-)		13	1.9 × 1.1 × 0.65		3:1	<table border="1"> <tr><th colspan="2">ATSLP-12-4 (-)</th></tr> <tr><td>13</td><td>1.9 × 1.1 × 0.65</td></tr> <tr><td></td><td>3:1</td></tr> </table>	ATSLP-12-4 (-)		13	1.9 × 1.1 × 0.65		3:1	<table border="1"> <tr><th colspan="2">ATSLP-14(-)</th></tr> <tr><td>15</td><td>1.9 × 1.5 × 0.65</td></tr> <tr><td></td><td>4:1</td></tr> </table>	ATSLP-14(-)		15	1.9 × 1.5 × 0.65		4:1	<table border="1"> <tr><th colspan="2">SC79 (-)</th></tr> <tr><td>2</td><td>1.6 × 0.8 × 0.55</td></tr> <tr><td></td><td>5:1</td></tr> </table>	SC79 (-)		2	1.6 × 0.8 × 0.55		5:1	<table border="1"> <tr><th colspan="2">SOT23 (-)</th></tr> <tr><td>3</td><td>2.9 × 2.4 × 1.1</td></tr> <tr><td></td><td>2:1</td></tr> </table>	SOT23 (-)		3	2.9 × 2.4 × 1.1		2:1
ATSLP-12-1 (-)																																		
13	1.9 × 1.1 × 0.65																																	
	3:1																																	
ATSLP-12-4 (-)																																		
13	1.9 × 1.1 × 0.65																																	
	3:1																																	
ATSLP-14(-)																																		
15	1.9 × 1.5 × 0.65																																	
	4:1																																	
SC79 (-)																																		
2	1.6 × 0.8 × 0.55																																	
	5:1																																	
SOT23 (-)																																		
3	2.9 × 2.4 × 1.1																																	
	2:1																																	
<table border="1"> <tr><th colspan="2">SOT323 (SC-70)</th></tr> <tr><td>3</td><td>2.0 × 2.1 × 0.9</td></tr> <tr><td></td><td>3:1</td></tr> </table>	SOT323 (SC-70)		3	2.0 × 2.1 × 0.9		3:1	<table border="1"> <tr><th colspan="2">SOT343 (SC-82)</th></tr> <tr><td>4</td><td>2.0 × 2.1 × 0.9</td></tr> <tr><td></td><td>3:1</td></tr> </table>	SOT343 (SC-82)		4	2.0 × 2.1 × 0.9		3:1	<table border="1"> <tr><th colspan="2">FWLP-6-1 (-)</th></tr> <tr><td>6</td><td>0.778 × 0.528 × 0.34</td></tr> <tr><td></td><td>6:1</td></tr> </table>	FWLP-6-1 (-)		6	0.778 × 0.528 × 0.34		6:1	<table border="1"> <tr><th colspan="2">TSFP-4 (-)</th></tr> <tr><td>4</td><td>1.4 × 1.2 × 0.55</td></tr> <tr><td></td><td>5:1</td></tr> </table>	TSFP-4 (-)		4	1.4 × 1.2 × 0.55		5:1	<table border="1"> <tr><th colspan="2">TSLP-2-1 (-)</th></tr> <tr><td>2</td><td>1.0 × 0.6 × 0.4</td></tr> <tr><td></td><td>5:1</td></tr> </table>	TSLP-2-1 (-)		2	1.0 × 0.6 × 0.4		5:1
SOT323 (SC-70)																																		
3	2.0 × 2.1 × 0.9																																	
	3:1																																	
SOT343 (SC-82)																																		
4	2.0 × 2.1 × 0.9																																	
	3:1																																	
FWLP-6-1 (-)																																		
6	0.778 × 0.528 × 0.34																																	
	6:1																																	
TSFP-4 (-)																																		
4	1.4 × 1.2 × 0.55																																	
	5:1																																	
TSLP-2-1 (-)																																		
2	1.0 × 0.6 × 0.4																																	
	5:1																																	
<table border="1"> <tr><th colspan="2">TSLP-2-7 (-)</th></tr> <tr><td>2</td><td>1.0 × 0.6 × 0.39</td></tr> <tr><td></td><td>5:1</td></tr> </table>	TSLP-2-7 (-)		2	1.0 × 0.6 × 0.39		5:1	<table border="1"> <tr><th colspan="2">TSLP-2-17 (-)</th></tr> <tr><td>2</td><td>1.0 × 0.6 × 0.39</td></tr> <tr><td></td><td>5:1</td></tr> </table>	TSLP-2-17 (-)		2	1.0 × 0.6 × 0.39		5:1	<table border="1"> <tr><th colspan="2">TSLP-2-19 (-)</th></tr> <tr><td>2</td><td>1.0 × 0.6 × 0.31</td></tr> <tr><td></td><td>5:1</td></tr> </table>	TSLP-2-19 (-)		2	1.0 × 0.6 × 0.31		5:1	<table border="1"> <tr><th colspan="2">TSLP-2-20 (-)</th></tr> <tr><td>2</td><td>1.0 × 0.6 × 0.31</td></tr> <tr><td></td><td>5:1</td></tr> </table>	TSLP-2-20 (-)		2	1.0 × 0.6 × 0.31		5:1	<table border="1"> <tr><th colspan="2">TSLP-3-1 (-)</th></tr> <tr><td>3</td><td>1.0 × 0.6 × 0.4</td></tr> <tr><td></td><td>5:1</td></tr> </table>	TSLP-3-1 (-)		3	1.0 × 0.6 × 0.4		5:1
TSLP-2-7 (-)																																		
2	1.0 × 0.6 × 0.39																																	
	5:1																																	
TSLP-2-17 (-)																																		
2	1.0 × 0.6 × 0.39																																	
	5:1																																	
TSLP-2-19 (-)																																		
2	1.0 × 0.6 × 0.31																																	
	5:1																																	
TSLP-2-20 (-)																																		
2	1.0 × 0.6 × 0.31																																	
	5:1																																	
TSLP-3-1 (-)																																		
3	1.0 × 0.6 × 0.4																																	
	5:1																																	
<table border="1"> <tr><th colspan="2">TSLP-3-9 (-)</th></tr> <tr><td>3</td><td>1.0 × 0.6 × 0.31</td></tr> <tr><td></td><td>5:1</td></tr> </table>	TSLP-3-9 (-)		3	1.0 × 0.6 × 0.31		5:1	<table border="1"> <tr><th colspan="2">TSLP-4-4 (-)</th></tr> <tr><td>4</td><td>1.2 × 0.8 × 0.4</td></tr> <tr><td></td><td>4:1</td></tr> </table>	TSLP-4-4 (-)		4	1.2 × 0.8 × 0.4		4:1	<table border="1"> <tr><th colspan="2">TSLP-4-11 (-)</th></tr> <tr><td>4</td><td>0.7 × 0.7 × 0.3</td></tr> <tr><td></td><td>4:1</td></tr> </table>	TSLP-4-11 (-)		4	0.7 × 0.7 × 0.3		4:1	<table border="1"> <tr><th colspan="2">TSLP-5-2 (-)</th></tr> <tr><td>5</td><td>1.3 × 0.8 × 0.39</td></tr> <tr><td></td><td>4:1</td></tr> </table>	TSLP-5-2 (-)		5	1.3 × 0.8 × 0.39		4:1	<table border="1"> <tr><th colspan="2">TSLP-6-2 (-)</th></tr> <tr><td>6</td><td>1.1 × 0.7 × 0.39</td></tr> <tr><td></td><td>4:1</td></tr> </table>	TSLP-6-2 (-)		6	1.1 × 0.7 × 0.39		4:1
TSLP-3-9 (-)																																		
3	1.0 × 0.6 × 0.31																																	
	5:1																																	
TSLP-4-4 (-)																																		
4	1.2 × 0.8 × 0.4																																	
	4:1																																	
TSLP-4-11 (-)																																		
4	0.7 × 0.7 × 0.3																																	
	4:1																																	
TSLP-5-2 (-)																																		
5	1.3 × 0.8 × 0.39																																	
	4:1																																	
TSLP-6-2 (-)																																		
6	1.1 × 0.7 × 0.39																																	
	4:1																																	
<table border="1"> <tr><th colspan="2">TSLP-6-3 (-)</th></tr> <tr><td>6</td><td>1.1 × 0.9 × 0.39</td></tr> <tr><td></td><td>4:1</td></tr> </table>	TSLP-6-3 (-)		6	1.1 × 0.9 × 0.39		4:1	<table border="1"> <tr><th colspan="2">TSLP-6-4 (-)</th></tr> <tr><td>6</td><td>1.1 × 0.7 × 0.31</td></tr> <tr><td></td><td>4:1</td></tr> </table>	TSLP-6-4 (-)		6	1.1 × 0.7 × 0.31		4:1	<table border="1"> <tr><th colspan="2">TSLP-7-1 (-)</th></tr> <tr><td>7</td><td>2.0 × 1.3 × 0.4</td></tr> <tr><td></td><td>3:1</td></tr> </table>	TSLP-7-1 (-)		7	2.0 × 1.3 × 0.4		3:1	<table border="1"> <tr><th colspan="2">TSLP-7-4 (-)</th></tr> <tr><td>7</td><td>2.3 × 1.5 × 0.4</td></tr> <tr><td></td><td>3:1</td></tr> </table>	TSLP-7-4 (-)		7	2.3 × 1.5 × 0.4		3:1	<table border="1"> <tr><th colspan="2">TSLP-7-6 (-)</th></tr> <tr><td>7</td><td>1.4 × 1.26 × 0.39</td></tr> <tr><td></td><td>3:1</td></tr> </table>	TSLP-7-6 (-)		7	1.4 × 1.26 × 0.39		3:1
TSLP-6-3 (-)																																		
6	1.1 × 0.9 × 0.39																																	
	4:1																																	
TSLP-6-4 (-)																																		
6	1.1 × 0.7 × 0.31																																	
	4:1																																	
TSLP-7-1 (-)																																		
7	2.0 × 1.3 × 0.4																																	
	3:1																																	
TSLP-7-4 (-)																																		
7	2.3 × 1.5 × 0.4																																	
	3:1																																	
TSLP-7-6 (-)																																		
7	1.4 × 1.26 × 0.39																																	
	3:1																																	
<table border="1"> <tr><th colspan="2">TSLP-9-3 (-)</th></tr> <tr><td>9</td><td>1.15 × 1.15 × 0.31</td></tr> <tr><td></td><td>5:1</td></tr> </table>	TSLP-9-3 (-)		9	1.15 × 1.15 × 0.31		5:1	<table border="1"> <tr><th colspan="2">TSLP-10-1 (-)</th></tr> <tr><td>10</td><td>1.55 × 1.15 × 0.31</td></tr> <tr><td></td><td>4:1</td></tr> </table>	TSLP-10-1 (-)		10	1.55 × 1.15 × 0.31		4:1	<table border="1"> <tr><th colspan="2">TSNP-6-2 (-)</th></tr> <tr><td>6</td><td>1.1 × 0.7 × 0.375</td></tr> <tr><td></td><td>4:1</td></tr> </table>	TSNP-6-2 (-)		6	1.1 × 0.7 × 0.375		4:1	<table border="1"> <tr><th colspan="2">TSNP-7-1 (-)</th></tr> <tr><td>7</td><td>2.0 × 1.3 × 0.375</td></tr> <tr><td></td><td>3:1</td></tr> </table>	TSNP-7-1 (-)		7	2.0 × 1.3 × 0.375		3:1	<table border="1"> <tr><th colspan="2">TSNP-7-6 (-)</th></tr> <tr><td>7</td><td>1.4 × 1.26 × 0.375</td></tr> <tr><td></td><td>3:1</td></tr> </table>	TSNP-7-6 (-)		7	1.4 × 1.26 × 0.375		3:1
TSLP-9-3 (-)																																		
9	1.15 × 1.15 × 0.31																																	
	5:1																																	
TSLP-10-1 (-)																																		
10	1.55 × 1.15 × 0.31																																	
	4:1																																	
TSNP-6-2 (-)																																		
6	1.1 × 0.7 × 0.375																																	
	4:1																																	
TSNP-7-1 (-)																																		
7	2.0 × 1.3 × 0.375																																	
	3:1																																	
TSNP-7-6 (-)																																		
7	1.4 × 1.26 × 0.375																																	
	3:1																																	

<p><b>TSNP-7-10 (-)</b></p> <p>7    <math>2.3 \times 1.7 \times 0.73</math></p>  <p>3:1</p>	<p><b>TSNP-8-1 (-)</b></p> <p>8    <math>1.1 \times 1.1 \times 0.375</math></p>  <p>3:1</p>	<p><b>TSNP-9-1 (-)</b></p> <p>8    <math>1.1 \times 1.1 \times 0.375</math></p>  <p>3:1</p>	<p><b>TSNP-10-1 (-)</b></p> <p>10    <math>1.5 \times 1.1 \times 0.375</math></p>  <p>3:1</p>	<p><b>TSNP-14-2 (-)</b></p> <p>15    <math>1.95 \times 1.8 \times 0.375</math></p>  <p>2:1</p>
<p><b>TSNP-14-3 (-)</b></p> <p>15    <math>1.95 \times 1.8 \times 0.375</math></p>  <p>2:1</p>	<p><b>TSNP-16-1 (-)</b></p> <p>16    <math>2.3 \times 2.3 \times 0.38</math></p>  <p>2:1</p>	<p><b>TSNP-16-6 (-)</b></p> <p>17    <math>2.3 \times 2.3 \times 0.73</math></p>  <p>2:1</p>	<p><b>TSNP-20-1 (-)</b></p> <p>21    <math>2.3 \times 2.3 \times 0.73</math></p>  <p>2:1</p>	<p><b>TSNP-26-2 (-)</b></p> <p>27    <math>3.4 \times 2.6 \times 0.73</math></p>  <p>2:1</p>
<p><b>TSNP-26-3 (-)</b></p> <p>17    <math>3.2 \times 2.8 \times 0.77</math></p>  <p>2:1</p>	<p><b>TSSLP-2-1 (-)</b></p> <p>2    <math>0.62 \times 0.32 \times 0.31</math></p>  <p>7:1</p>	<p><b>TSSLP-2-2 (-)</b></p> <p>2    <math>0.62 \times 0.32 \times 0.31</math></p>  <p>7:1</p>	<p><b>TSSLP-2-3 (-)</b></p> <p>2    <math>0.62 \times 0.32 \times 0.31</math></p>  <p>5:1</p>	<p><b>TSSLP-2-4 (-)</b></p> <p>2    <math>0.62 \times 0.32 \times 0.31</math></p>  <p>5:1</p>
<p><b>WLL-2-1 (-)</b></p> <p>2    <math>0.58 \times 0.28 \times 0.15</math></p>  <p>10:1</p>	<p><b>WLL-2-2 (-)</b></p> <p>2    <math>0.43 \times 0.23 \times 0.15</math></p>  <p>12:1</p>			

## Support Material

More detailed information on each product is available at [www.infineon.com/rf](http://www.infineon.com/rf). Click on a specific product name to find datasheets, application notes, device libraries with Spice models and S-parameter files, products and application brochures, sample kits, etc.

Application Notes / Data Sheets / Evaluation Boards / Technical Reports	<a href="http://www.infineon.com/rf">http://www.infineon.com/rf</a>
Products <ul style="list-style-type: none"> <li>- RF CMOS Switches</li> <li>- Antenna Tuners</li> <li>- LTE MMIC LNAs</li> <li>- LTE RF Modules</li> <li>- RF MMICs</li> <li>- RF Transistors</li> <li>- RF Diodes</li> <li>- ESD/EMI Protection Devices</li> </ul>	<a href="http://www.infineon.com/rfswitches">www.infineon.com/rfswitches</a> <a href="http://www.infineon.com/AntennaTuners">www.infineon.com/AntennaTuners</a> <a href="http://www.infineon.com/ltelna">www.infineon.com/ltelna</a> <a href="http://www.infineon.com/ltelmm">www.infineon.com/ltelmm</a> <a href="http://www.infineon.com/rfmmics">www.infineon.com/rfmmics</a> <a href="http://www.infineon.com/rftransistors">www.infineon.com/rftransistors</a> <a href="http://www.infineon.com/rfdiodes">www.infineon.com/rfdiodes</a> <a href="http://www.infineon.com/ESDdiodes">www.infineon.com/ESDdiodes</a>
Brochures: <ul style="list-style-type: none"> <li>- RF Frontend Selection Guide</li> <li>- RF Discretes Selection Guide</li> <li>- Application Guide for Mobile Communication</li> </ul>	<a href="http://www.infineon.com/rf">http://www.infineon.com/rf</a> <a href="http://www.infineon.com/rf">http://www.infineon.com/rf</a> <a href="http://www.infineon.com/appguide_rf_mobile">www.infineon.com/appguide_rf_mobile</a>
Simulation Models and Libraries Application Examples	<a href="http://www.infineon.com/rf">www.infineon.com/rf</a> → Simulation <a href="http://www.infineon.com/tools">www.infineon.com/tools</a> → Simulation Models (SPICE, S-parameters, SABER)

#### **Trademarks**

All referenced product or service names and trademarks are the property of their respective owners.

**Edition <2018-10-26>**

**Published by**

**Infineon Technologies AG**

**81726 Munich, Germany**

**© 2018 Infineon Technologies AG.**

**All Rights Reserved.**

**Do you have a question about this document?**

**Email: [erratum@infineon.com](mailto:erratum@infineon.com)**

**Document reference**

**AN\_1810\_PL55\_1810\_100951**

#### **IMPORTANT NOTICE**

The information contained in this application note is given as a hint for the implementation of the product only and shall in no event be regarded as a description or warranty of a certain functionality, condition or quality of the product. Before implementation of the product, the recipient of this application note must verify any function and other technical information given herein in the real application. Infineon Technologies hereby disclaims any and all warranties and liabilities of any kind (including without limitation warranties of non-infringement of intellectual property rights of any third party) with respect to any and all information given in this application note.

The data contained in this document is exclusively intended for technically trained staff. It is the responsibility of customer's technical departments to evaluate the suitability of the product for the intended application and the completeness of the product information given in this document with respect to such application.

For further information on the product, technology delivery terms and conditions and prices please contact your nearest Infineon Technologies office ([www.infineon.com](http://www.infineon.com)).

#### **WARNINGS**

Due to technical requirements products may contain dangerous substances. For information on the types in question please contact your nearest Infineon Technologies office.

Except as otherwise explicitly approved by Infineon Technologies in a written document signed by authorized representatives of Infineon Technologies, Infineon Technologies' products may not be used in any applications where a failure of the product or any consequences of the use thereof can reasonably be expected to result in personal injury.

## Looking for pricing, stock, or lifecycle information?

Click below to explore more details on WIN SOURCE:

- [View BGM13HBA9E6327XTSA1 on WIN SOURCE](#)
- [Infineon Technologies Information](#)

## Optimize Your Supply Chain with WIN SOURCE Solutions

- ✓ Global Sourcing Solution
- ✓ Obsolete Management
- ✓ Cost Control Management
- ✓ Shortage Management
- ✓ Alternative Solution
- ✓ Excess Inventory Management