



**THE DATASHEET OF
BD8665GW-E2**



Battery Charger IC Series

Boost DC/DC Charger With Input Current Limiter

BD8664GW BD8665GW BD8668GW

General Description

BD8664GW, BD8665GW and BD8668GW are lithium-ion battery charger IC's, suitable for charging 2S batteries from a 5V source, such as a USB port with DC/DC boost topology.

Features

- CP/CV Charging
- Charge-On/ Off control available with EN pin
- Integrated Input Detection (VBUSOK)
- Integrated Power Good
- Boost Switching Topology
- Low Ron integrated MOSFET
- Output Short Circuit Protection
- 0.4mm pitch Chip Scale Package (UCSP75M2)

Applications

DVC, DSC, MID and other Lithium battery-powered portable devices

Key Specifications

- Input Current Accuracy ±2%(BD8664GW)
±3%(BD8665GW/BD8668GW)
- Charging Voltage Accuracy ±0.5%
- Selectable Input Current 100mA/500mA/900mA/1500mA (max)
- Charging frequency 1MHz (typ)
- Input Standby Current 71µA(typ)
- battery leakage current while charging is off 0µA(typ)

Package

UCSP75M2

W(Typ) x D(Typ) x H(Max)
2.20mm x 2.20mm x 0.85mm

Line Up

Charge Voltage	Package	Pin number	Orderable Part Number
8.30V	UCSP75M2	20	BD8664GW
8.40V		25	BD8665GW

Typical Application Circuit

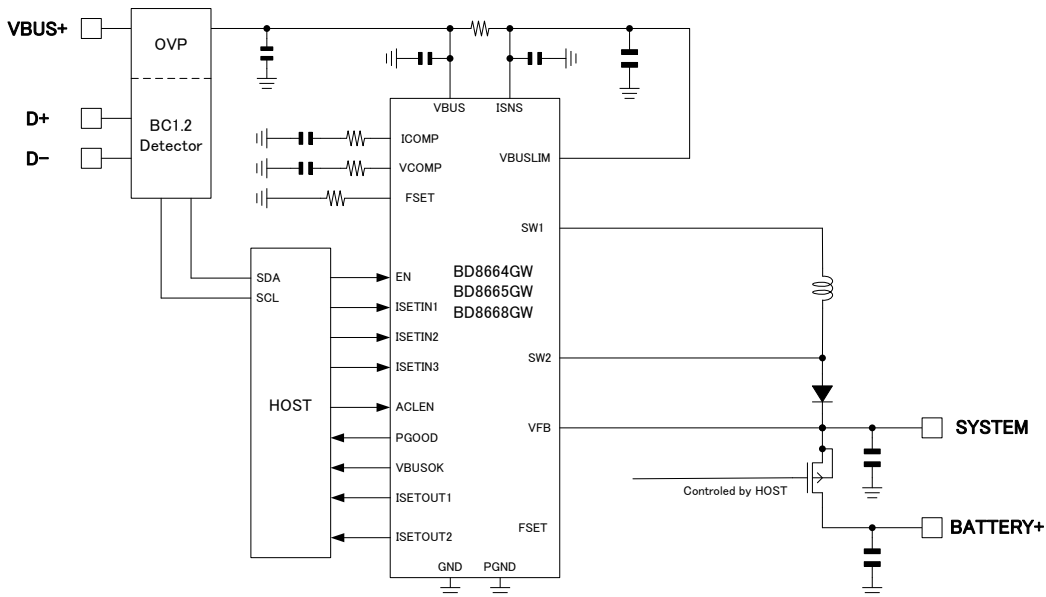

Figure 1. Typical Application

○Product structure : Silicon monolithic integrated circuit ○This product has no designed protection against radioactive rays

Contents

General Description.....	1
Features.....	1
Applications	1
Key Specifications.....	1
Package W(Typ) x D(Typ) x H(Max).....	1
Line Up.....	1
Typical Application Circuit.....	1
Pin Configuration (TOP VIEW).....	3
Pin Description	3
Block Diagram.....	5
Absolute Maximum Ratings (Ta=25°C)	6
Recommended Operating Conditions (Ta=-30 to +85°C).....	6
Electrical Characteristics	7
Typical Performance Curves.....	9
Reference Data.....	14
Block Descriptions	16
Timing Chart/Application Information.....	18
Application Components Selection.....	21
Example of Recommended Circuit.....	22
Input/Output Pin Immediate Circuit.....	23
Thermal Reduction Characteristics	25
Operational Notes	26
Ordering Information	28
Marking Diagrams.....	28
Physical Dimensions, Tape and Reel information	29
Revision History	32

Pin Configuration (TOP VIEW)

BD8664GW / BD8665GW

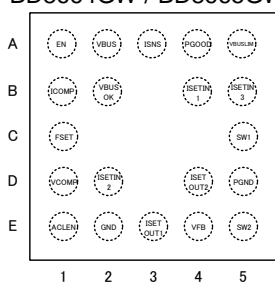

BD8668GW

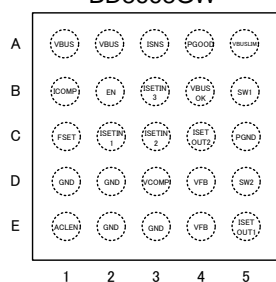

Pin Description

BD8664GW / BD8665GW

No.	Name	I/O	Description
A1	EN	I	Charging ON/OFF
A2	VBUS	I	Power input
A3	ISNS	I	Current sensing
A4	PGOOD	O	Power GOOD output
A5	VBUSLIM	O	VBUS current limiter output
B1	ICOMP	O	Pin for phase compensation of constant current
B2	VBUSOK	O	VBUSOK output
B3	-	-	-
B4	ISETIN1	I	Current setting pin1
B5	ISETIN3	I	Current setting pin3
C1	FSET	I	Frequency setting pin
C2	-	-	-
C3	-	-	-
C4	-	-	-
C5	SW1	O	Inductor connection pin1
D1	VCOMP	O	Pin for phase compensation of constant current connection
D2	ISETIN2	I	Current setting pin2
D3	-	-	-
D4	ISETOUT2	O	Current setting output2
D5	PGND	I	Power GND(0.0V)
E1	ACLEN	I	Automatic current ON/OFF selection pin
E2	GND	I	GND(0.0V)
E3	ISETOUT1	O	Current setting output 1
E4	VFB	I	Feedback pin of CV charging voltage
E5	SW2	O	Inductor connection pin2

No upper ESD protection diodes are connected to ISETIN1, ISETIN2, ISETIN3, and EN.

Pin Description – continued

BD8668GW

No.	Name	I/O	Description
A1	VBUS	I	Power input
A2	VBUS	I	Power input
A3	ISNS	I	Current sensing
A4	PGOOD	O	Power GOOD output
A5	VBUSLIM	O	VBUS current limiter output
B1	ICOMP	O	Pin for phase compensation of constant current
B2	EN	I	Charging ON/OFF
B3	ISETIN3	I	Current setting pin3
B4	VBUSOK	O	VBUSOK output
B5	SW1	O	Inductor connection pin1
C1	FSET	I	Frequency setting pin
C2	ISETIN1	I	Current setting pin1
C3	ISETIN2	I	Current setting pin2
C4	ISETOUT2	O	Current setting output2
C5	PGND	I	Power GND (0.0V)
D1	GND	I	GND (0.0V)
D2	GND	I	GND (0.0V)
D3	VCOMP	O	Pin for phase compensation of constant current connection
D4	VFB	I	Feedback pin of CV charging voltage
D5	SW2	O	Inductor connection pin2
E1	ACLEN	I	Automatic current ON/OFF selection pin
E2	GND	I	GND (0.0V)
E3	GND	I	GND (0.0V)
E4	VFB	I	Feedback pin of CV charging voltage
E5	ISETOUT1	O	Current setting output 1

No upper ESD protection diodes are connected to ISETIN1, ISETIN2, ISETIN3, and EN.

Absolute Maximum Ratings (Ta=25°C)

Item	Symbol	Range	Unit
VBUS Voltage	V _{VBUS}	-0.3 to +7.0	V
VBUSLIM Voltage	V _{VBUSLIM}	-0.3 to V _{VBUS} +0.3 (Note 3)	V
VFB Voltage	V _{VFB}	-0.3 to +13.0	V
SW1 Voltage	V _{SW1}	-0.3 to V _{VBUSLIM} +0.3 (Note 4)	V
SW2 Voltage	V _{SW2}	-0.3 to V _{VFB} +0.3	V
Terminal Voltage 1 (Note 1)	V _{INOUT1}	-0.3 to V _{VBUS} +0.3 (Note 3)	V
Terminal Voltage 2 (Note 2)	V _{INOUT2}	-0.3 to +6.0	V
Voltage Between Terminals (Note 5)	V _{INOUT3}	-0.3 to +0.3	V
Maximum Power Dissipation (Note 6)	P _d	1.00	W
Operating Temperature	T _{opr}	-30 to +85	°C
Storage Temperature	T _{stg}	-55 to +150	°C
Junction Temperature	T _{jmax}	+150	°C

(Note 1) ISNS, FSET, VBUSOK, PGOOD, VCOMP, ICOMP, ISETOUT1, ISETOUT2

(Note 2) ACLEN, EN, ISETIN1, ISETIN2, ISETIN3

(Note 3) 7.0V against GND

(Note 4) 7.0V against PGND

(Note 5) GND-PGND, VBUS-ISNS

(Note 6) When mounted on 54mm x 62mm PCB. P_d decreases by 8mW per 1°C when Ta is 25°C or higher.

Caution: Operating the IC over the absolute maximum ratings may damage the IC. The damage can either be a short circuit between pins or an open circuit between pins and the internal circuitry. Therefore, it is important to consider circuit protection measures, such as adding a fuse, in case the IC is operated over the absolute maximum ratings.

Recommended Operating Conditions (Ta=-30 to +85°C)

Item	Symbol	Value			Unit	Part No.
		Min	Typ	Max		
VBUS Voltage	V _{VBUS}	4.1	5.0	5.5	V	-
VFB Voltage	V _{VFB}	0.0	8.4	10.0	V	BD8665GW/BD8668GW
			8.3			BD8664GW

Electrical Characteristics

(Unless otherwise specified, $V_{VBUS}=5.0V$ $V_{VFB}=7.4V$ $V_{ISETIN1,2,3}=0V$ $GND=PGND=0V$ $T_a=25^{\circ}C$)

Item	Symbol	Value			Unit	Conditions
		Min	Typ	Max		
VBUS Stand-by Current	I_{VBUS1}	-	71	142	μA	$V_{EN}=0.0V$, Only VBUSOK is ON
VBUS Operational Current	I_{VBUS2}	-	2	5	mA	No Switching
Battery Stand-by Current	I_{BATT1}	-1	0	+1	μA	$V_{EN}=0.0V$
Battery Operational Current	I_{BATT2}	-	60	120	μA	No Switching
Frequency 1	F_{OSC1}	0.9	1.0	1.1	MHz	$R_{FSET}=47k\Omega$
Frequency 2	F_{OSC2}	(1.8)	2.0	(2.2)	MHz	$R_{FSET}=22k\Omega$
FSET Output Voltage	V_{FSET}	-	0.6	-	V	
<Constant Voltage Control Block>						
Constant Voltage Charging Accuracy	V_{CV2}	8.258	8.300	8.342	V	$\pm 0.5\%$, BD8664GW
	V_{CV2}	8.358	8.400	8.442	V	$\pm 0.5\%$, BD8665GW/BD8668GW
<VBUSLIM Current Control Block>						
VBUSLIM Current Accuracy (VBUS-ISNS Voltage)	$I_{VBUSLIM1}$	6.0	8.0	10.0	mV	$V_{ISETIN1}=0.0V$, $V_{ISETIN2}=0.0V$
	$I_{VBUSLIM2}$	47.0	48.5	50.0	mV	$V_{ISETIN1}=0.0V$, $V_{ISETIN2}=3.3V$
	$I_{VBUSLIM3}$	85.2	87.0	88.8	mV	$V_{ISETIN1}=3.3V$, $V_{ISETIN2}=0.0V$ BD8664GW, $\pm 2\%$
		84.0		90.0	mV	$V_{ISETIN1}=3.3V$, $V_{ISETIN2}=0.0V$ BD8665GW/BD8668GW, $\pm 3\%$
	$I_{VBUSLIM4}$	142.1	145.0	147.9	mV	$V_{ISETIN1}=3.3V$, $V_{ISETIN2}=3.3V$ BD8664GW, $\pm 2\%$
		140.0		150.0	mV	$V_{ISETIN1}=3.3V$, $V_{ISETIN2}=3.3V$ BD8665GW/BD8668GW, $\pm 3\%$
VBUSLIM Current Limiter Level (VBUS-ISNS Voltage)	$I_{VBUSOCP}$	(+15)	+20	(+30)	mV	Against The Current Set By $V_{VBUSLIM}$
<PGOOD Block>						
PGOOD H Voltage	V_{PGOODH}	2.94	3.00	3.06	V	$\pm 2\%$
PGOOD L Voltage	V_{PGOODL}	-	0.0	-	V	
<VBUSOK Pin >						
VBUS Threshold 1	$V_{VBUSOKTH1}$	3.9	4.0	4.1	V	$V_{BUS}=L$ to H
VBUS Threshold 2	$V_{VBUSOKTH2}$	3.8	3.9	4.0	V	$V_{BUS}=H$ to L
VBUSOK L->H Delay Time	$V_{VBUSOKDELAY}$	20	40	-	ms	
VBUSOK H Voltage	$V_{VBUSOKH}$	2.94	3.00	3.06	V	$\pm 2\%$
VBUSOK L Voltage	$V_{VBUSOKL}$	-	0.0	-	V	
<Comparator Block>						
VBUS UVLO Threshold	$V_{VBUSUVLON}$	3.40	3.60	3.80	V	
VBUS UVLO Unlock Threshold Voltage	$V_{VBUSUVLOFF}$	3.50	3.70	3.90	V	
VFB Low Voltage Detection1	V_{VFBV1}	-	2.4	-	V	VFB = H to L
VFB Low Voltage Detection2	V_{VFBV2}	-	2.6	-	V	VFB = L to H
VFB Overvoltage Detection1	V_{VFBV1}	8.5	9.0	9.5	V	VFB = H to L
VFB Overvoltage Detection2	V_{VFBV2}	9.2	9.7	10.2	V	VFB = L to H
VBUS Current Automatic Selection Voltage 1	$V_{VBUSAUTOTH}$	3.9	4.0	4.1	V	$V_{BUS}=H$ to L
VBUS Current Automatic Selection Voltage 1	$V_{VBUSAUTOTH}$	4.0	4.1	4.2	V	$V_{BUS}=L$ to H
<Power MOSFET>						
VBUSLIM-SW1 PMOS Ron	R_{SW1A}	-	70	-	m Ω	$I_{SW1}=-10mA$
VBUSLIM-SW1small PMOS Ron	R_{SW1B}	-	20	-	Ω	$I_{SW1}=-10mA$
SW2-PGND NMOS Ron	R_{SW2}	-	60	-	m Ω	$I_{SW2}=10mA$
SW2 Max Duty Width	$T_{SW2MAXDUTY}$	-	80	-	ns	$R_{FSET}=47k\Omega$
SW2 Min Duty Ratio	$T_{SW2MINDUTY}$	-	0	-	%	$R_{FSET}=47k\Omega$

Electrical Characteristics - continued

<Input/ Output>						
EN/ISETIN1,2,3/ACLEN L Voltage	V_{INL}	-	-	0.4	V	
EN/ISETIN1,2,3/ACLEN H Voltage	V_{INH}	2.5	-	5.5	V	
ISETIN1,2 Input Current	I_{INH}	-	0	-	μA	No Pull-Down, Open Is Not Allowed.
EN/ACLEN/ISETIN3 Pull-Down Resistor	R_{IN2}	300	500	700	k Ω	
ISETOUT1,2 L Voltage	V_{OUTL}	-	0.0	-	V	
ISETOUT1,2 H Voltage	V_{OUTH}	2.94	3.00	3.06	V	

This product has no designed protection against radioactive rays.

P_d is the maximum power. Please keep the current to meet power lower than the P_d .

Typical Performance Curves

(Unless otherwise specified, $V_{V_{BUS}}=5.0V$ $V_{V_{FB}}=7.4V$ $V_{I_{SETIN1,2,3}}=0V$ $GND=PGND=0V$ $T_a=25^\circ C$)

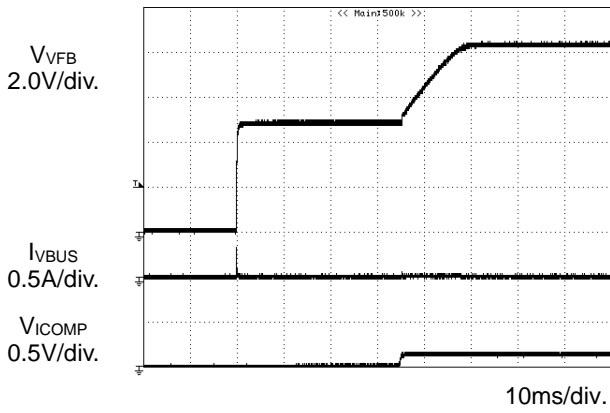

Figure 3. Feeding Mode Ramp-up (No Load)

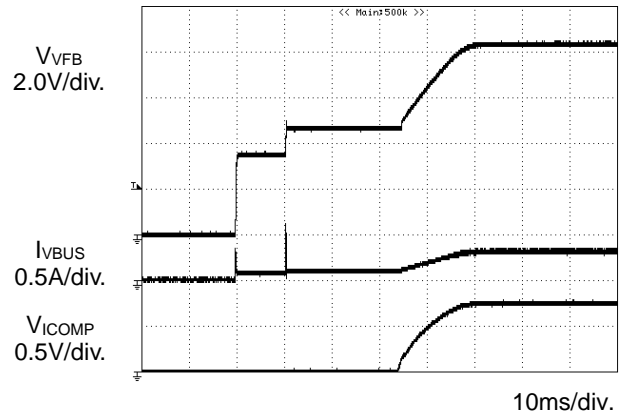

Figure 4. Feeding Mode Ramp-up (50Ω Load)

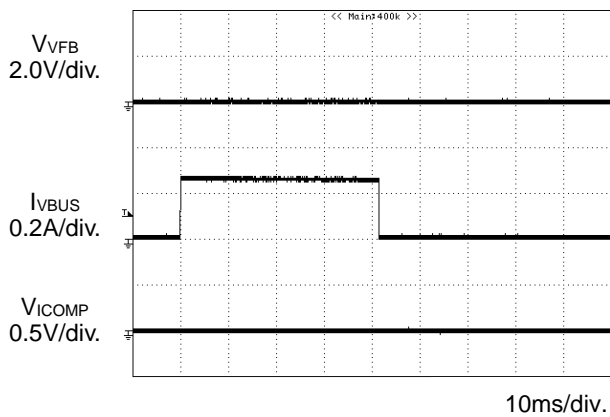

Figure 5. Start-up Waveform (VFB is Shorten to Ground)

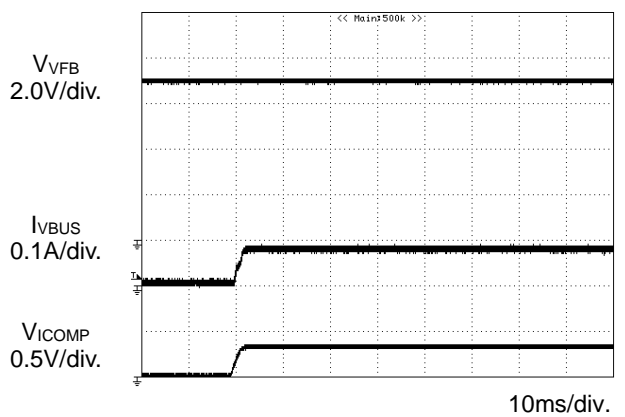

Figure 6. Charging Mode Start-up (100mA mode)

Typical Performance Curves - continue

(Unless otherwise specified, $V_{VBUS}=5.0V$ $V_{VFB}=7.4V$ $V_{ISETIN1,2,3}=0V$ $GND=PGND=0V$ $T_a=25^\circ C$)

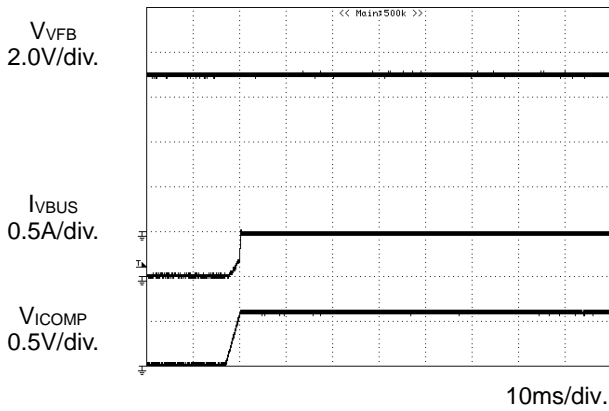

Figure 7. Charging Mode Start-up (500mA Mode)

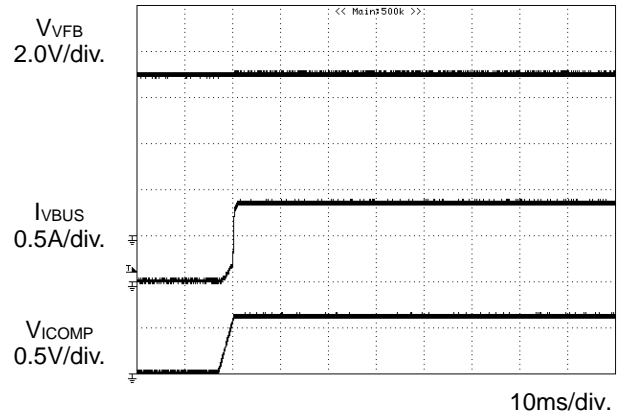

Figure 8. Charging Mode Start-up (900mA Mode)

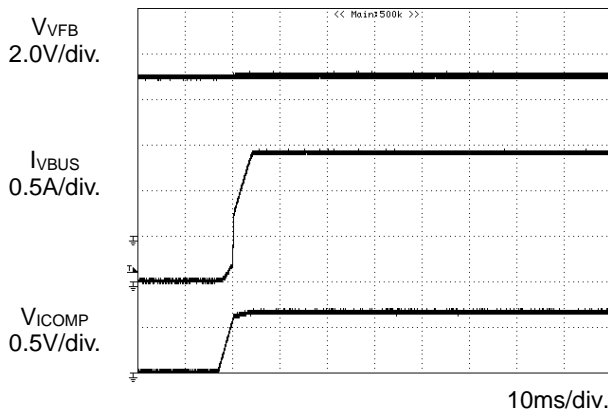

Figure 9. Charging Mode Start-up (1500mA Mode)

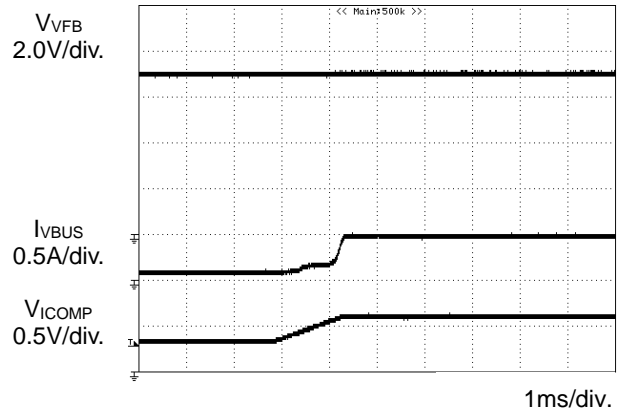

Figure 10. Changing Current (100mA to 500mA)

Typical Performance Curves - continue

(Unless otherwise specified, $V_{V_{BUS}}=5.0V$ $V_{V_{FB}}=7.4V$ $V_{I_{SETIN1,2,3}}=0V$ $GND=PGND=0V$ $T_a=25^\circ C$)

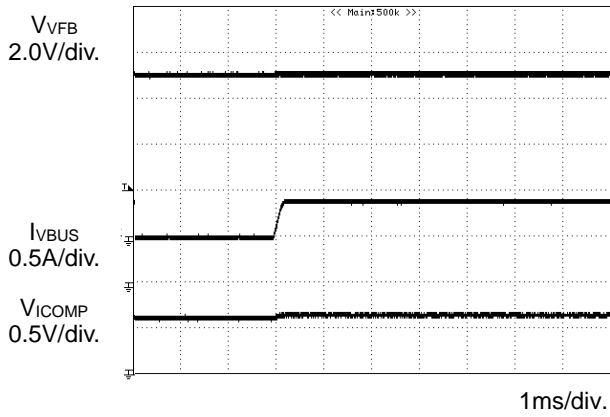

Figure 11. Changing Current (500mA to 900mA)

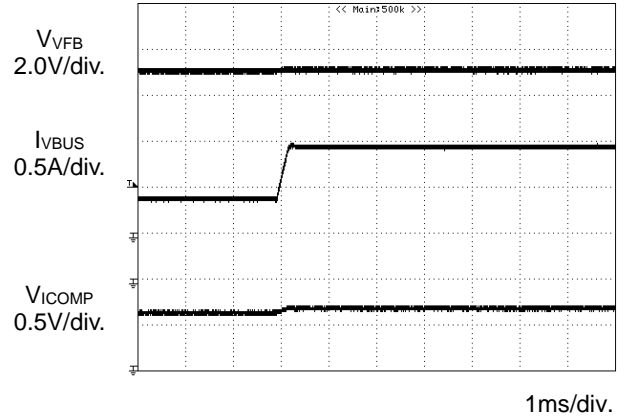

Figure 12. Changing Current (900mA to 1500mA)

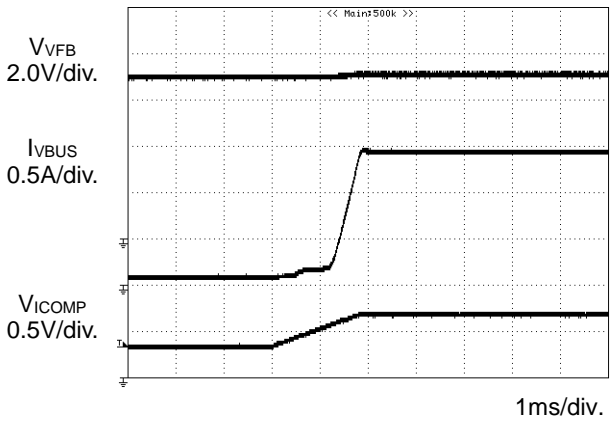

Figure 13. Changing Current (100mA to 1500mA)

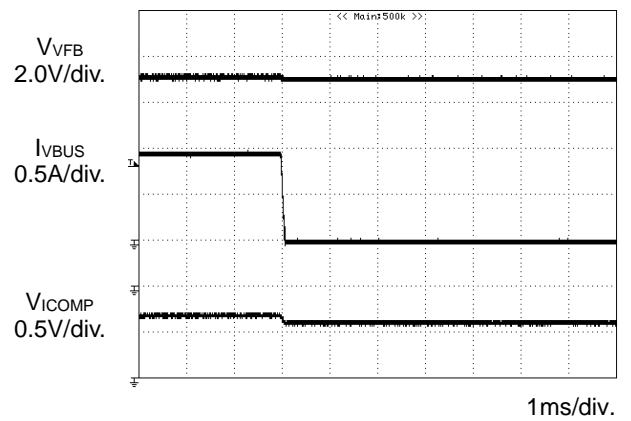

Figure 14. Changing Current (1500mA to 500mA)

Typical Performance Curves - continue

(Unless otherwise specified, $V_{VBUS}=5.0V$ $V_{VFB}=7.4V$ $V_{ISETIN1,2,3}=0V$ $GND=PGND=0V$ $T_a=25^\circ C$)

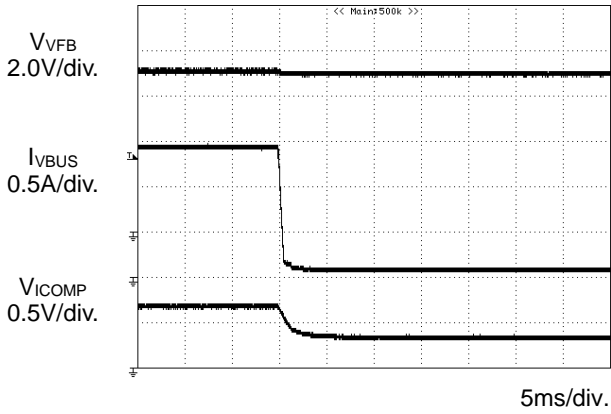

Figure 15. Changing Current
(1500mA to 100mA)

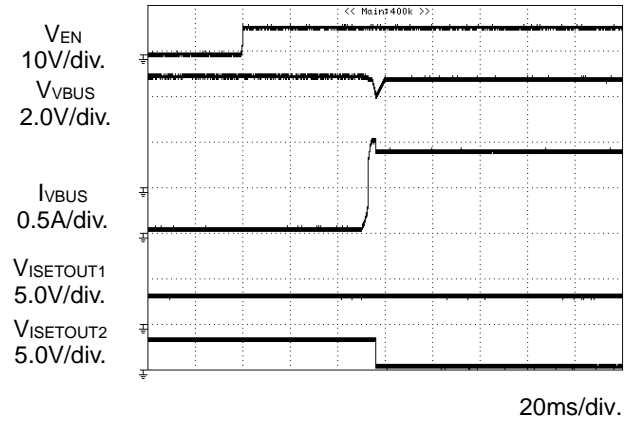

Figure 16. Automatically Changing Current
(1500mA to 900mA)

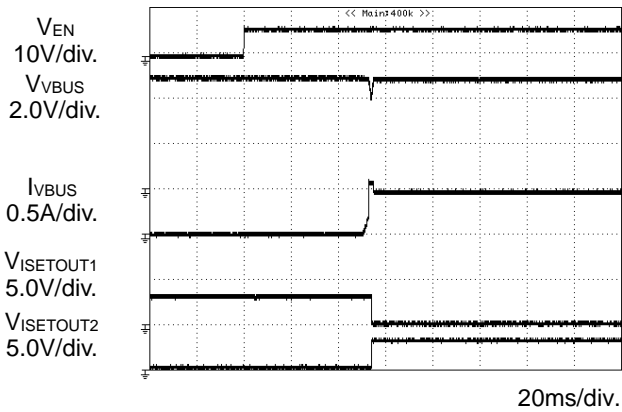

Figure 17. Automatically Changing Current
(900mA to 500mA)

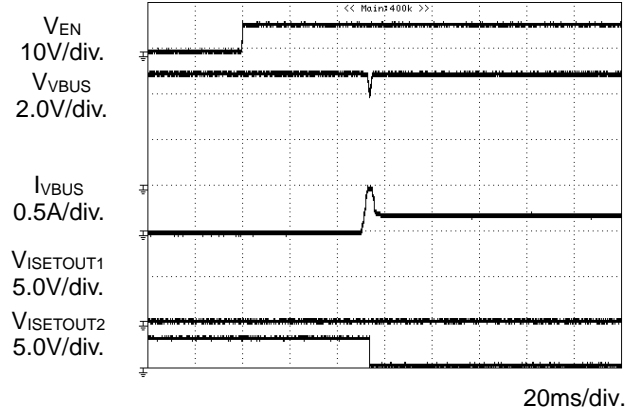

Figure 18. Automatically Changing Current
(500mA to 100mA)

Typical Performance Curves - continue

(Unless otherwise specified, $V_{VBUS}=5.0V$ $V_{VFB}=7.4V$ $V_{ISETIN1,2,3}=0V$ $GND=PGND=0V$ $T_a=25^\circ C$)

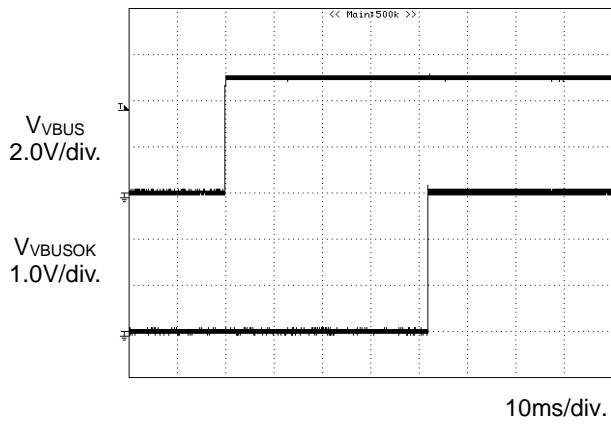

Figure 19. VBUSOK (L to H Delay Time)

Reference Data

(Unless otherwise specified, $V_{VBUS}=5.0V$ $V_{VFB}=7.4V$ $V_{ISETIN1,2,3}=0V$ $GND=PGND=0V$ $T_a=25^{\circ}C$)

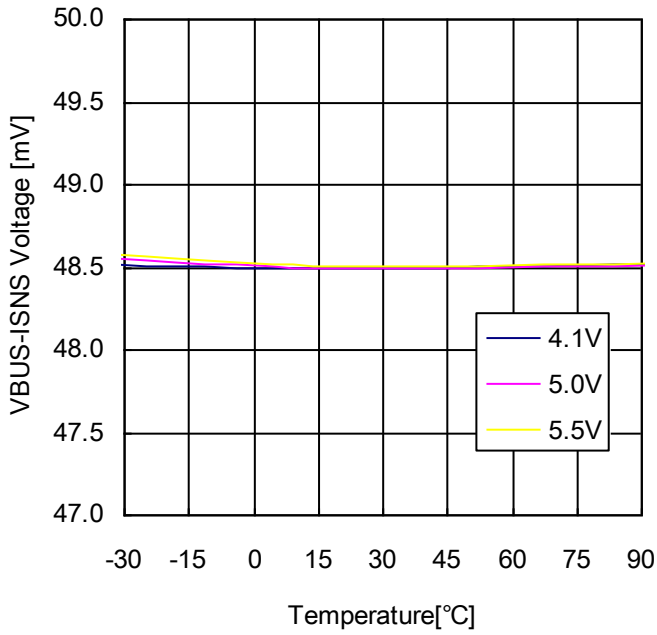

Figure 20. CV Voltage vs Temperature

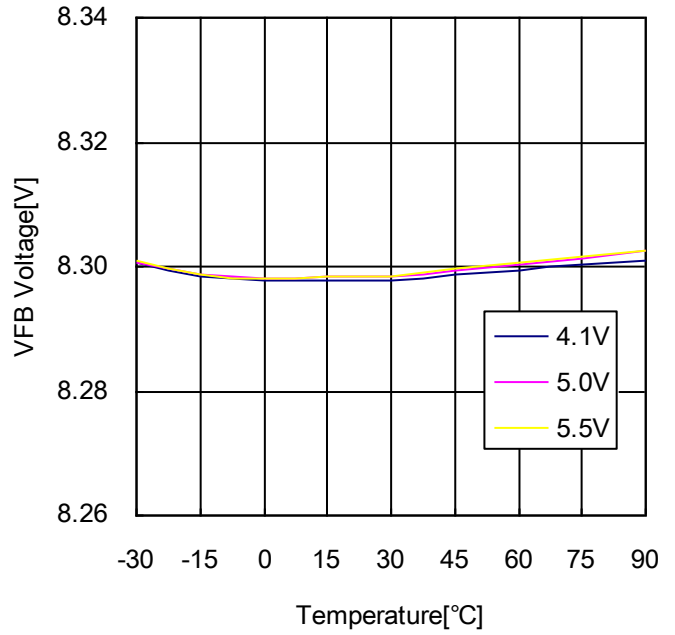

Figure 21. CV Voltage VBUS Voltage Dependency (BD8664GW)

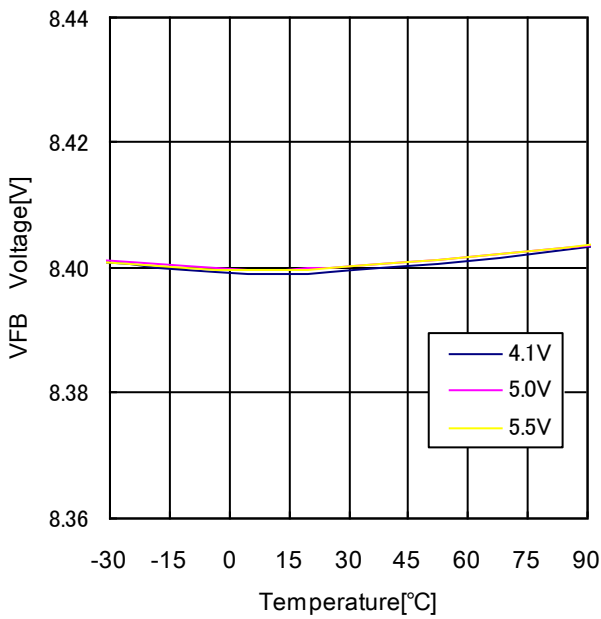

Figure 22. CV Voltage VBUS Voltage Dependency (BD8665GW/BD8668GW)

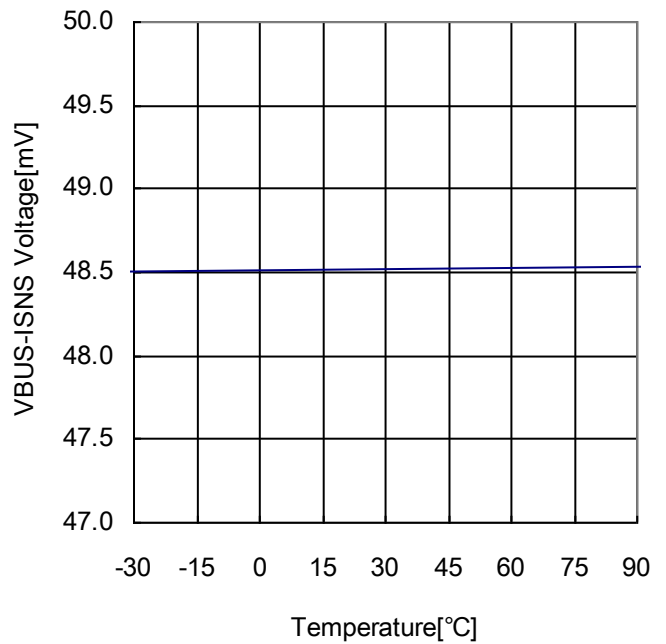

Figure 23. 500mA Mode CP Current Temperature Characteristic

Reference Data - continue

(Unless otherwise specified, $V_{VBUS}=5.0V$ $V_{VFB}=7.4V$ $V_{ISETIN1,2,3}=0V$ $GND=PGND=0V$ $T_a=25^\circ C$)

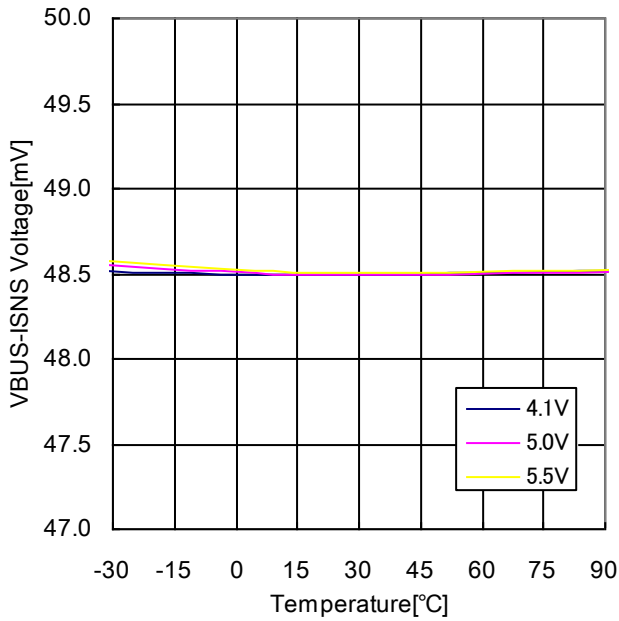

Figure 24. 500mA Mode CP Current VBUS Dependency

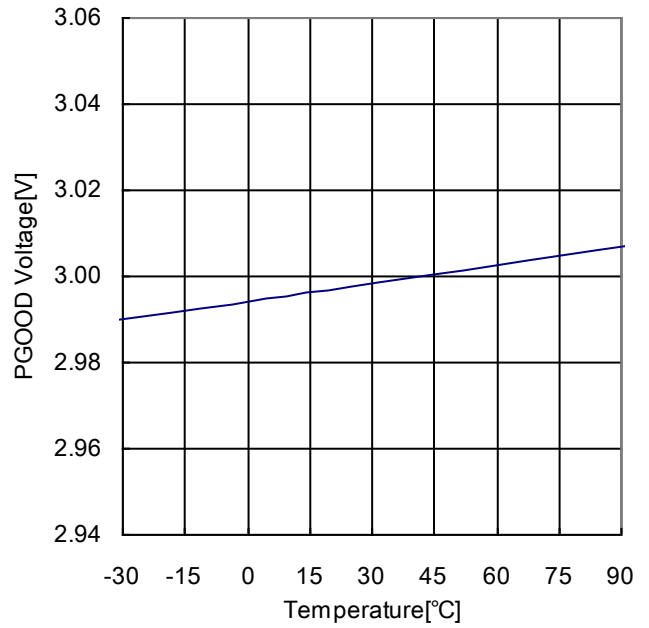

Figure 25. PGOOD Pin H Voltage Temperature Characteristic

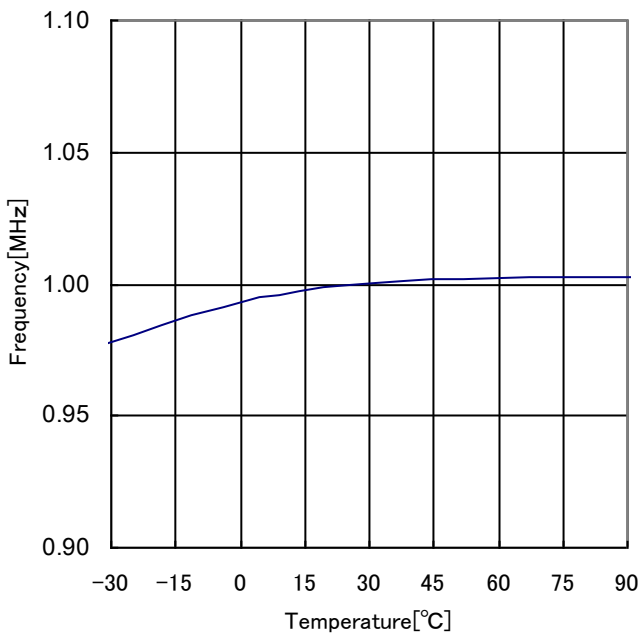

Figure 26. Frequency Temperature Characteristic

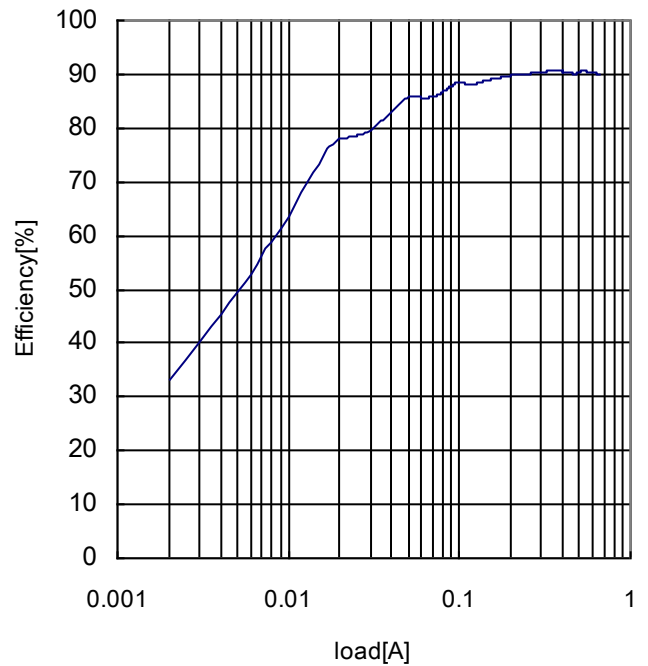

Figure 27. Efficiency 500mA Mode

Block Descriptions**1. VBUS Input Detection Comparator Output (VBUSOK)**

VBUS voltage can set VBUSOK. 40ms after detecting that VBUS is higher than 4.0V (typ), VBUSOK turns H (3.0V [typ]). In case VBUS ramps down, and reaches 3.9V (typ), VBUSOK turns L without any delay. The function works independently from the condition of EN and thermal shut down.

VBUS	VBUSOK
< 3.9V (typ)	L 0.0V (typ)
>= 4.0V (typ)	H 3.0V (typ)

2. Charging ON/OFF (EN)

ON/OFF is controlled with the EN pin. When EN is L, the IC enters shutdown mode (or USB suspend mode), the battery leakage current is set to 0μA, and all other functions but VBUSOK turns off. EN pin is connected to a 500kΩ (typ) pull-down resistor.

3. USB Current Setting (ISETIN1,2,3)

ISET1	ISET2	ISET3	VBUS Input Current Settings
L	L	L	100mA (max)
L	L	H	500mA (max)
L	H	L	500mA (max)
L	H	H	500mA (max)
H	L	L	900mA (max)
H	L	H	900mA (max)
H	H	L	1500mA (max)
H	H	H	1500mA (max)

Note: Open is NOT allowed for ISETIN1,2 pins. No pull-down resistor is connected to ISETIN1, 2 pins. 500kΩ (typ) pull-down resistor is internally connected to ISETIN3.

4. VBUS Current Setting (ISETOUT1,2)

ISETOUT1	ISETOUT2	VBUS Current Settings
L	L	100mA (max)
L	H	500mA (max)
H	L	900mA (max)
H	H	1500mA (max)

Note: 500kΩ(typ) is connected internally to ISETOUT1,2. Even in the case VBUS=0V, the output stays stable.

5. Frequency Setting (FSET)

The PWM switching frequency can be set.

FSET	PWM
100kΩ	500kHz (typ)
47kΩ	1MHz (typ)
33kΩ	1.5MHz (typ)
22kΩ	2MHz (typ)

6. CV Control Soft-Start

If the system boots up with NO battery, CV control method suppresses the 8.3V (typ) in case of using BD8664GW and 8.4V (typ) in case of using BD8665GW/BD8668GW, on VFB pin, and enters "feeding mode". In this mode, it will take 40ms (typ) for the VFB to reach 8.4V (typ).

7. Load Switch Function

A PMOS load switch is integrated between VBUSLIM and SW1. When EN=L, the load switch turns off. If a low battery is connected, charging can be stopped. The integrated load resistors are 20Ω (typ) and 70mΩ (typ). The higher resistance is connected during start-up. After 10ms (typ), the lower resistance is connected if no short circuit is detected by VFB pin.

8. OCP for Load Switch

Through a sense resistor between VBUS and ISNS, over-current can be detected while the load switch is on. If the over-current is constantly detected for more than 1ms, the load switch turns off and latches, and PGOOD is set L. To unlatch, the IC must be rebooted by switching EN to low, then back to high; or set VBUS to a voltage lower than UVLO, then back to the operating VBUS voltage.

9. Battery Low Voltage Detection (Output SCP)

If during start-up, the battery's voltage is lower than VFB voltage or the output is shorted to ground, the low-side load switch will never be turned on, and the high-side load switch will be on for 80ms (typ). But, if the high-side load switch is kept on for more than 80ms, the load switch is turned off. This function is off after the PGOOD is turned H.

10. Power Good (PGOOD)

The IC is enabled by EN pin. After CV, CP, and soft start, PGOOD condition changes its state from L to H. Inversely, during thermal shutdown, overvoltage battery and OCP, PGOOD is L.

11. Battery Overvoltage Detection

Due to the VBUS current limiter, overvoltage can occur at VFB terminal during CP charging. This can cause damage to devices that are connected to the IC. To prevent this, overvoltage protection is integrated. Once overvoltage is detected, SW2 becomes Hi-Z, the error amp output and soft start are reset to default, and PGOOD is set L. Once VFB voltage is at a safe level, the IC automatically restarts with soft start.

12. Auto VBUS Current Setting

Once VBUS voltage exceeds 4.1V (typ), the VBUS current set to ISET1 to 3 pins are automatically changed from 1500mA (max) to 900mA (max), from 900mA (max) to 500mA (max), and from 500mA (max) to 100mA (max), while VBUS is continuously monitored. If ISET1 to 3 are changed after the auto change is done, the initial current that has been set to ISET1 to 3 will be employed again.

Notes:

- (1) If VBUS voltage remains lower than 4.1V and current is changed from 1500mA to 900mA, the current will not be changed to 500mA.
- (2) ACLEN has a pull-up resistor. The pin is L if it is open and auto setting becomes active.
- (3) It can be turned off by setting ACLEN to H.
- (4) It starts to work after the lower resistance load is turned on. Until PGOOD is changed to H, the bus current value is determined only by ISETIN1 to 3 and will not to be changed by VFB low voltage function.

13. Feeding Mode and Charging Mode

Feeding Mode: If the system boots up with NO battery to the IC, CV control method suppresses 8.3V (typ) for BD8664GW and 8.4V (typ) for BD8665GW/BD8668GW on VFB pin. During the feeding mode, the constant voltage is done by the VFB pin.

Charging Mode: If the system boots up with a battery to the IC, CP/CV control method is employed. During charging mode, the CV/CP function is applied to the battery. The two modes, however, are not internally controllable by the IC. An application that applies constant output voltage with CV charging is called "feeding mode" and another application that charges with CV/ CP charging is called "charging mode" in this technical note.

Timing Chart/Application Information

1. VBUSOK/VBUS Threshold at Automatic Change Current Setting

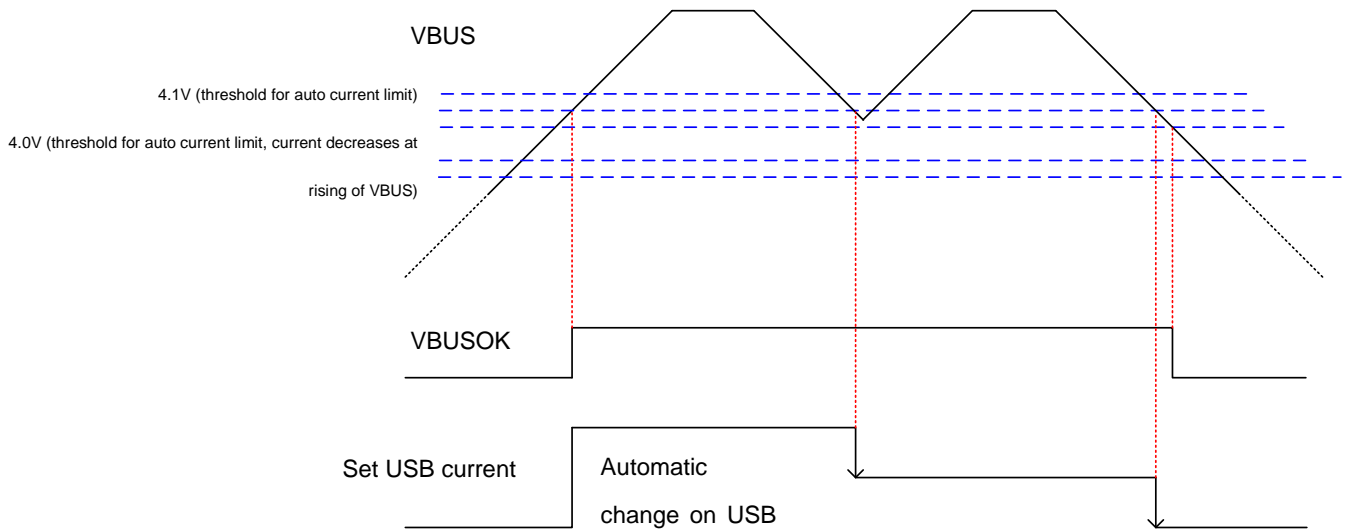

Figure 28. VBUSOK/VBUS Threshold at Automatic Change Current Setting waveform

1. Start-up Waveform at Feeding Mode (No Battery, Light Load)

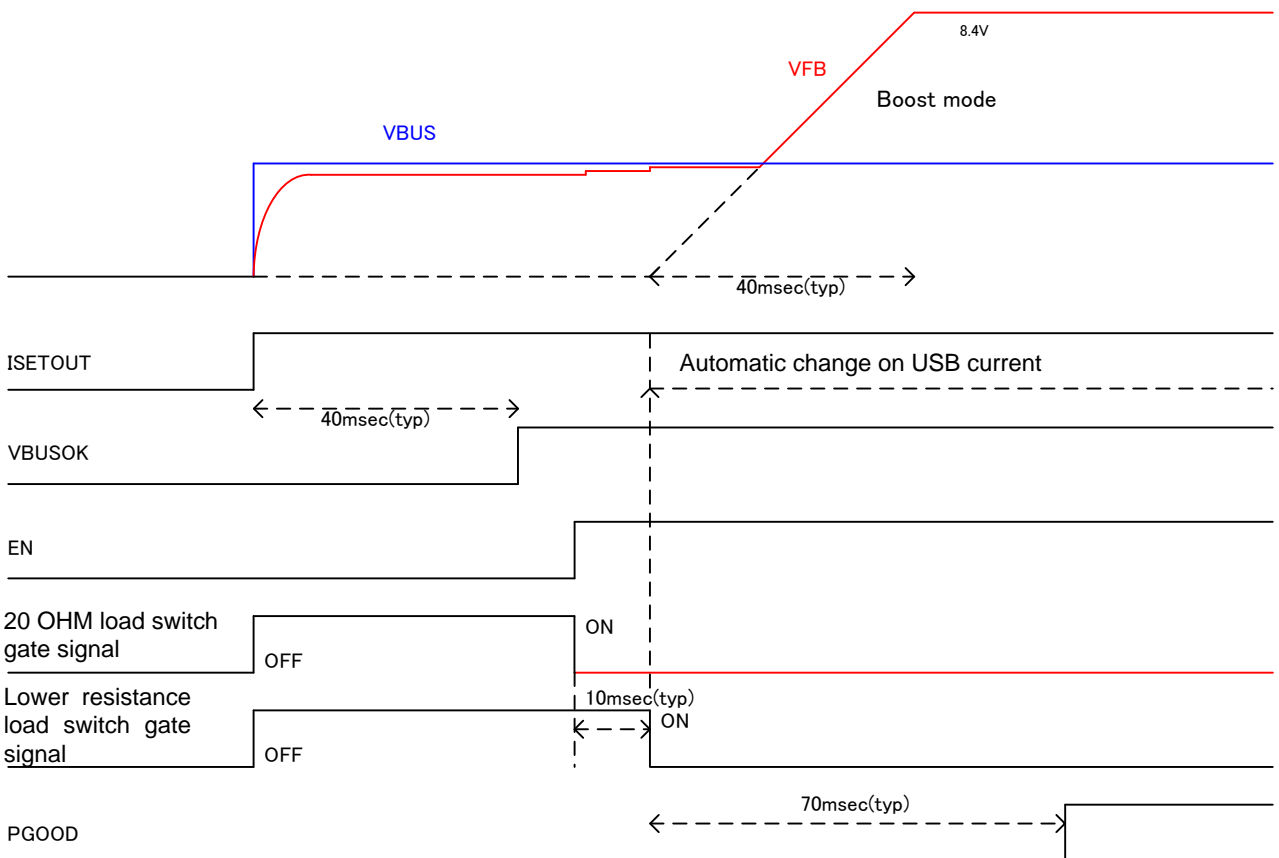

Figure 29. Start-up Waveform at Feeding Mode

2. Start-up Waveform at Feeding Mode (No Battery, 50Ω Load)

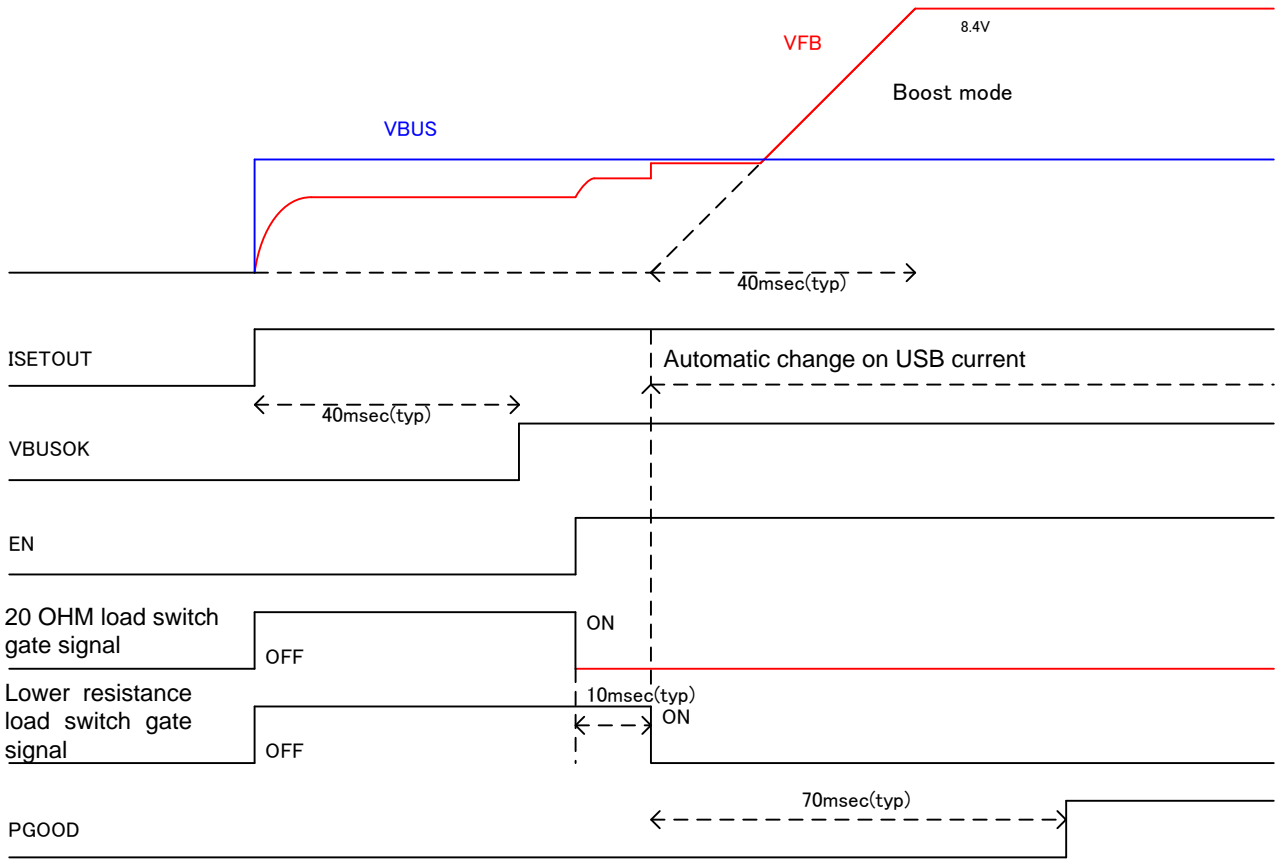

Figure 30. Start-up Waveform at Feeding Mode (No Battery, 50Ω Load)

3. Start-up Waveform at Feeding Mode (No battery, Heavy Load [Short to Ground])

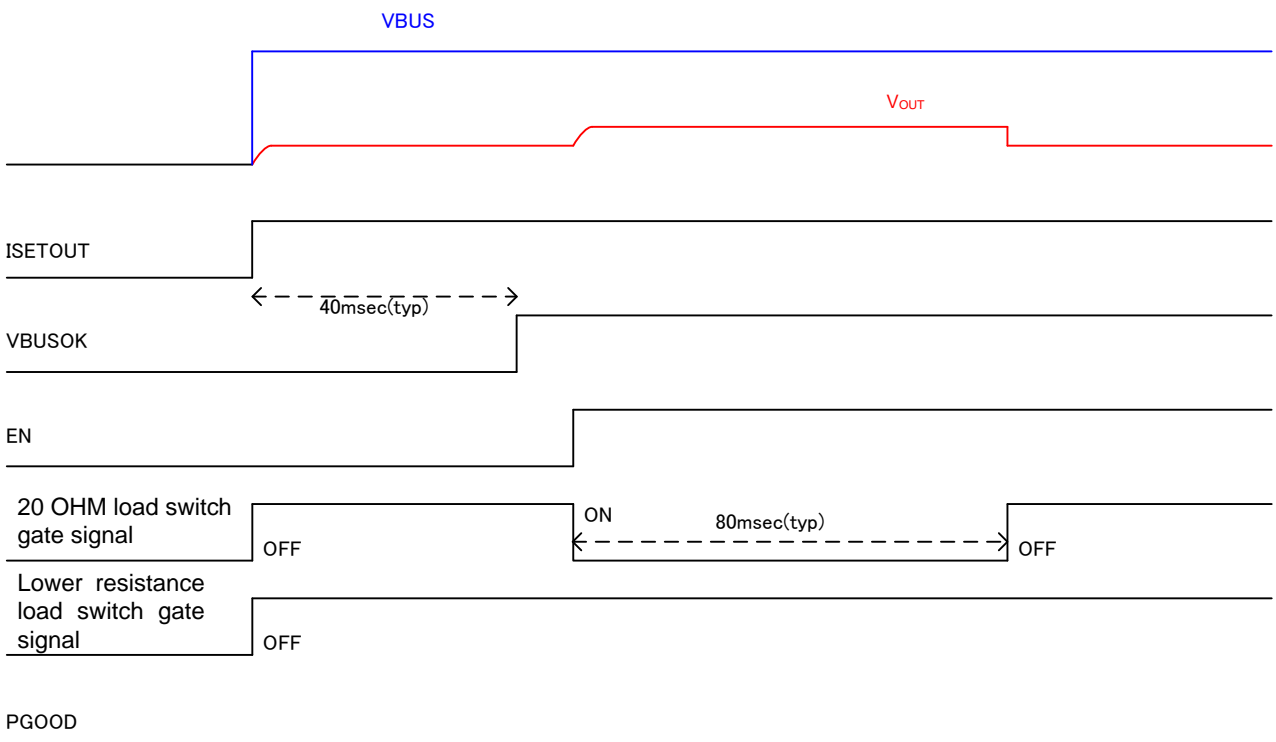

Figure 31. Start-up Waveform at Feeding Mode (No battery, Heavy Load [Short to Ground])

4. Voltage Waveform to PGOOD at Charging Mode (With Battery)

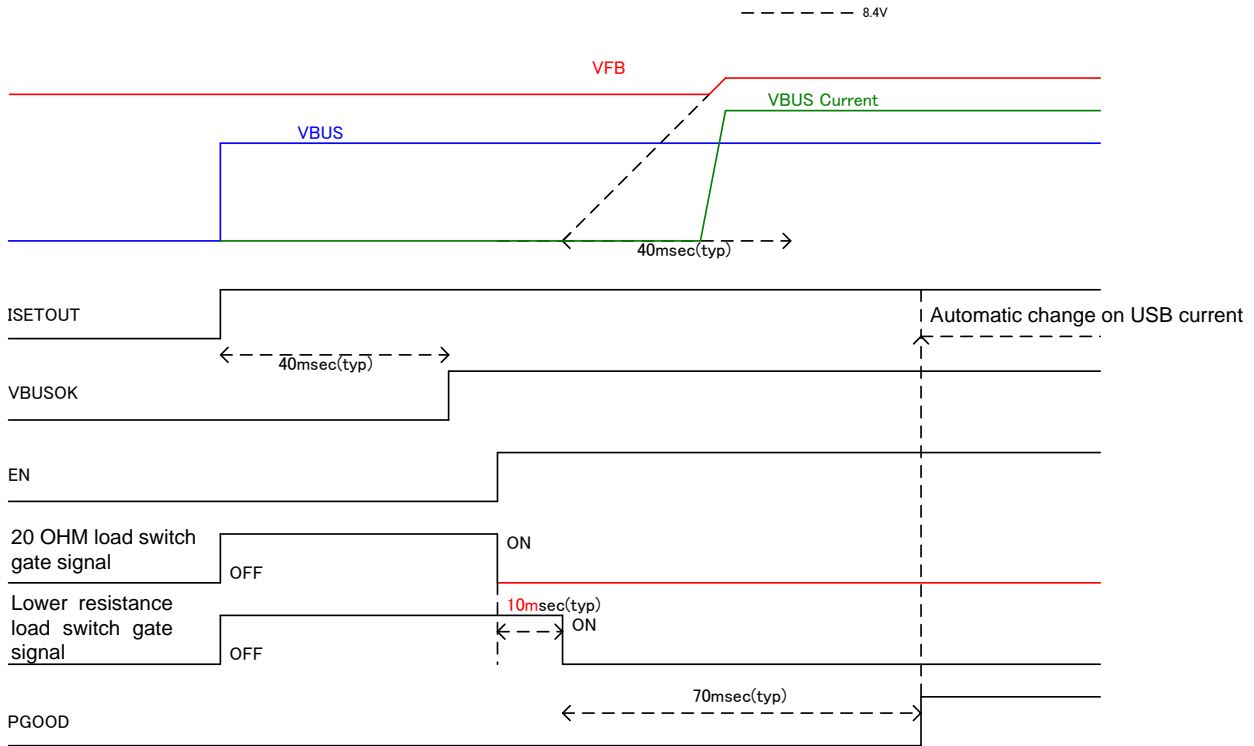

Figure 32. Voltage Waveform to PGOOD at Charging Mode (With Battery)

5. Operation from Feeding Mode to Charging Mode

During feeding mode, after the output started up with 8.3V(typ) for BD8664GW and 8.4V(typ) for BD8665GW/BD8668GW, if the battery has to be connected and the mode has to change to charging mode, set EN to L then H to enable CP charging. This turns PGOOD pin to L then H. Note that VBUS current may exceed the set value unless the EN is set L once.

6. Operation from Charging Mode To Feeding Mode

During charging mode, if the mode has to change to feeding mode, set the EN to L, detach the battery, then set EN to H again. This turns PGOOD pin to L, ramps up VFB to 8.3V (typ) for BD8664GW and 8.4V (typ) for BD8665GW/BD8668GW by feeding mode, and turns PGOOD to H, afterwards. Note that the overcurrent protection may occur unless the EN is set L like aforementioned VFB overvoltage detection waveform.

7. Battery Overvoltage Detection Waveform

During charging, if the battery is detached by a user, V_{OUT} will go higher as the mode changes to feeding mode. In this scenario, to prevent damage to devices connected to this IC, OVP is integrated. PGOOD has to be turned off to L when OVP is detected. Soft-start is again implemented when V_{OUT} goes low due to its output load.

In the application circuit example, note that the VFB node goes down to VBUS -1Vf, as determined by an external schottky diode.

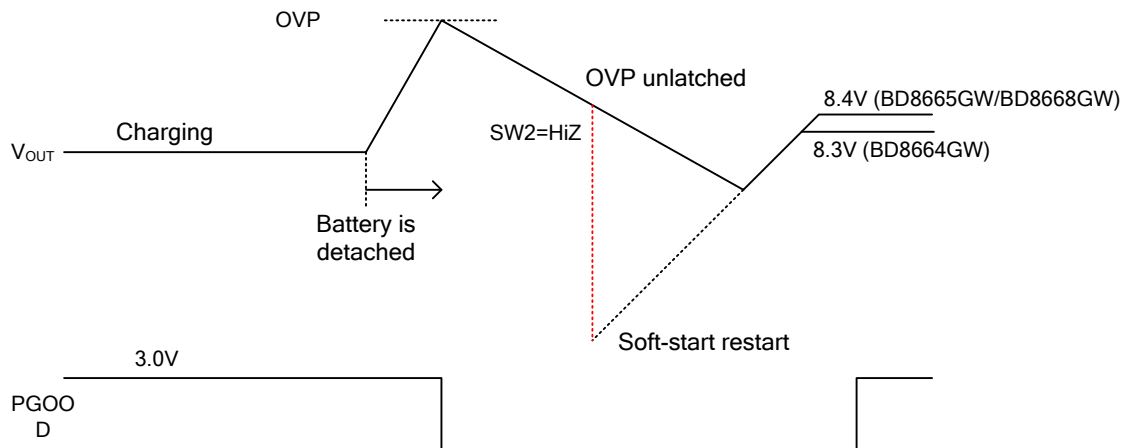

Figure 33. Battery Overvoltage Detection Waveform

8. Precaution on Voltage Application between Constant-Voltage Charging Voltage and OVP

When the voltage between constant-voltage charging voltage and OVP is applied to the VFB node, (e.g., An AC adapter is unplugged when the AC adapter voltage is applied to the VFB pin), the VFB terminal drops drastically, so avoid the above mentioned condition.

Application Components Selection

1. Frequency Setting (FSET) Resistor

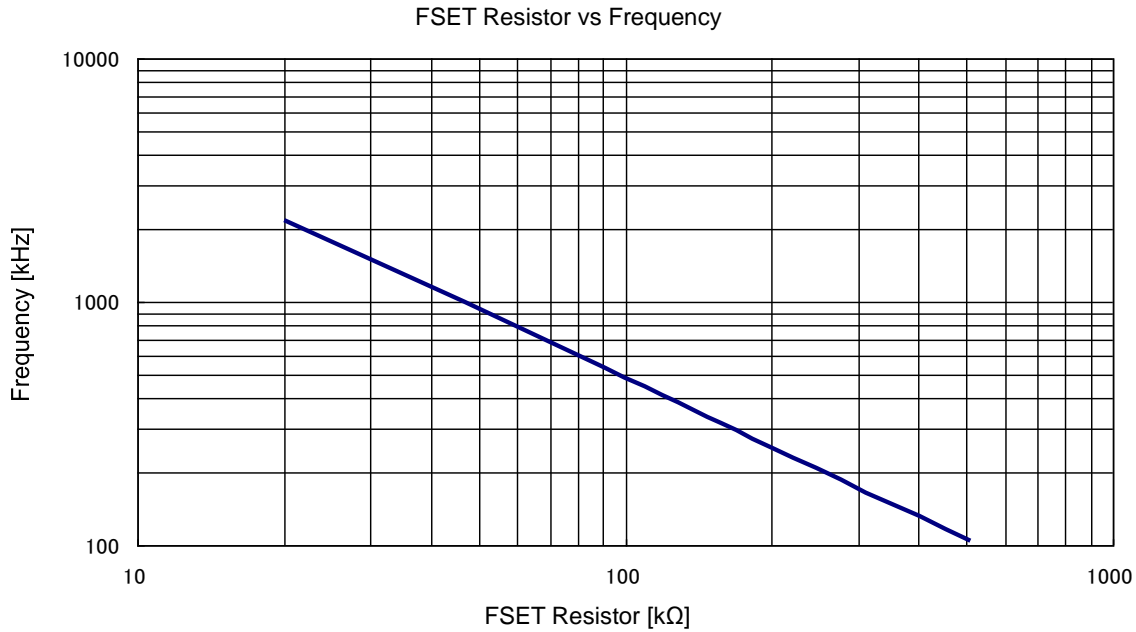

Figure 34.. Frequency Setting (F_{SET}) Resistor

2. Inductor Selection

Inductance for the boost switching affects its ripple current and ripple current at feeding mode. The ripple voltage is inversely proportional to the inductance and switching frequency so that the inductance must be higher if the frequency is lower. In other words, the inductance can be smaller if the frequency is higher. However, if the inductance changes, since the LC cutoff frequency changes, the phase compensation of ICOMP and VCOMP may have to be changed.

PWM	Inductance	Output Capacitance	ICOMP Time Constant	VCOMP Coefficient
1MHz(typ)	4.7μH	40μF	200Ω, 0.1μF serial	47kΩ, 0.1μF serial

※If the external coefficient is changed from the designated value above, check the open-loop gain phase carefully.

Example of Recommended Circuit

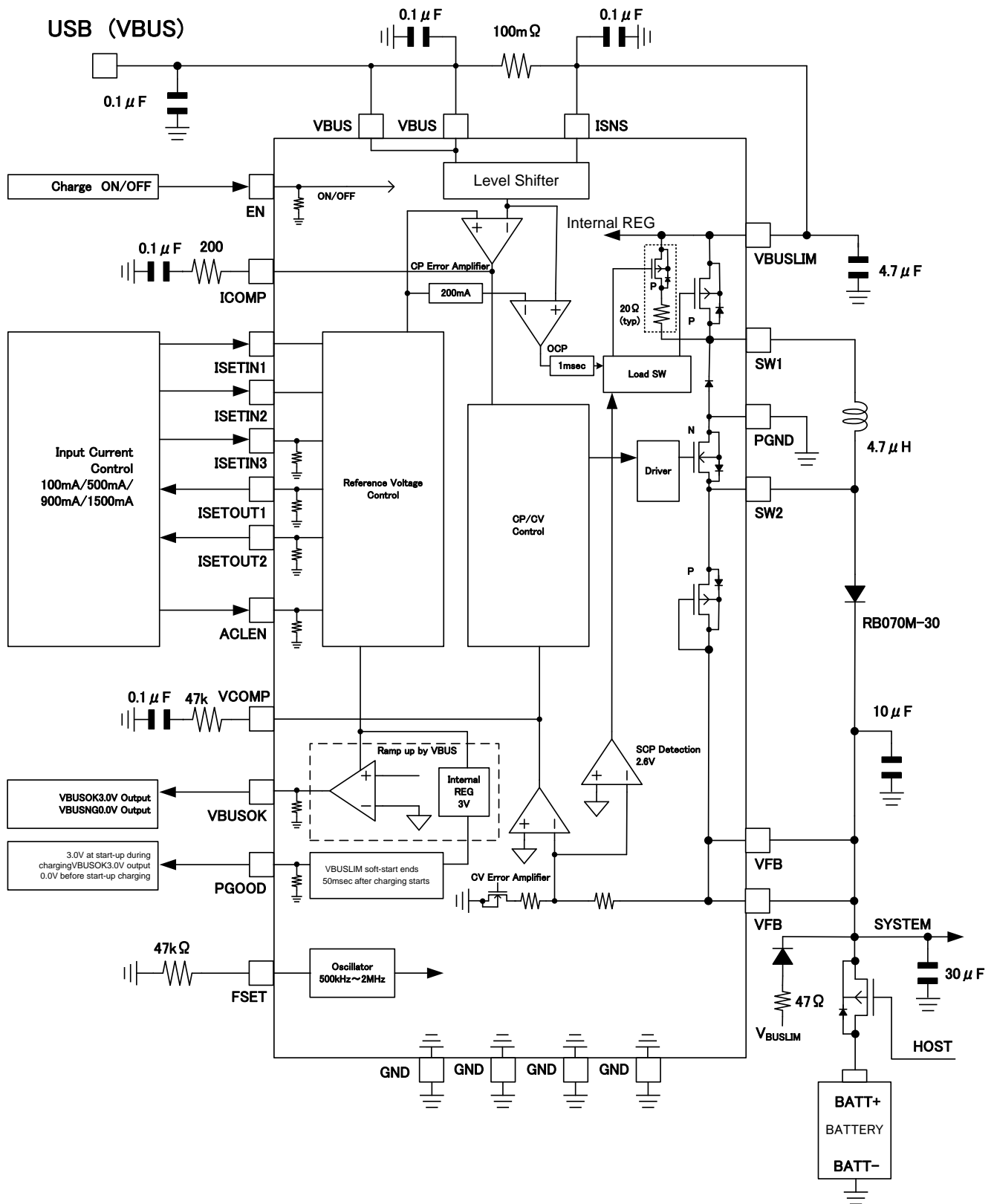

Figure 35. Example of Recommended Circuit

Input/Output Pin Immediate Circuit

Pin No. (BD8668GW)	Pin Name	Pin Immediate Circuit	Function
A1/A2	VBUS		USB power input
A5	VBUSLIM		USB current limiter
D1/D2 /E2/E3	GND		Ground
C5	PGND		Power Ground
A3	ISNS		Current detection amp input
A4 B4 C4 E5	PGOOD VBUSOK ISETOUT2 ISETOUT1		Logic output (with pull-down resistor)
B1 D3	ICOMP VCOMP		Error amp output
B2 E1 B3	EN ACLEN ISETIN3		Logic input (with pull-down resistor)

Input/Output Pin Immediate Circuit - continued

Pin No. (BD8668GW)	Pin Name	Pin Immediate Circuit	Function
C2 C3	ISETIN1 ISETIN2		Logic input (without pull-down resistor)
B5	SW1		Load switch output Inductor connection 1
C1	FSET		Frequency setting resistor terminal
D4 E4	VFB VFB		CV charging voltage feed-back terminal
D5	SW2		Boost switching terminal Inductor connection 2

Thermal Reduction Characteristics

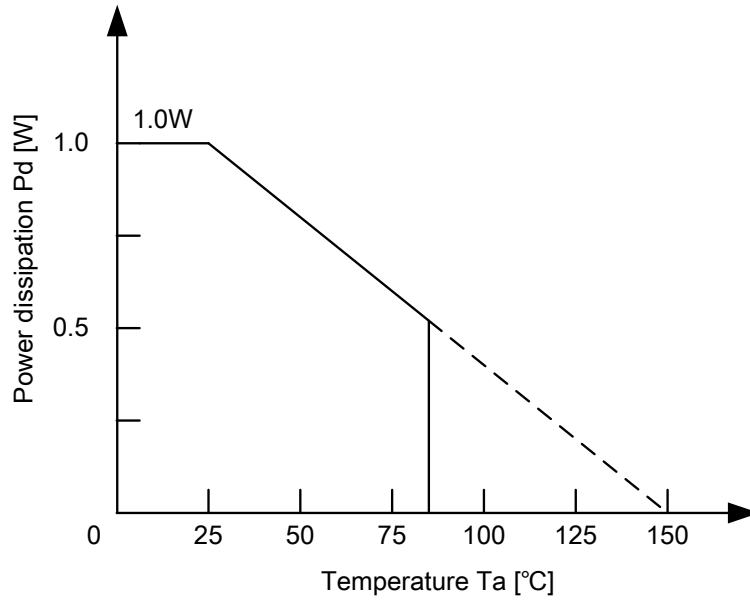

Figure 36.. Power Dissipation (Mounted on a 4-layer substrate board)

Operational Notes

1. Reverse-Connection of Power Supply Connector

Connecting the power supply in reverse polarity can damage the IC. Take precautions against reverse polarity when connecting the power supply, such as mounting an external diode between the power supply and the IC's power supply terminals.

2. Power Supply Line

Design the PCB layout pattern to provide low impedance supply lines. Separate the ground and supply lines of the digital and analog blocks to prevent noise in the ground and supply lines of the digital block from affecting the analog block. Furthermore, connect a capacitor to ground at all power supply pins. Consider the effect of temperature and aging on the capacitance value when using electrolytic capacitors.

3. Ground Potential

Ensure that no pins are at a voltage below that of the ground pin at any time, even during transient condition.

4. Ground Wiring Pattern

When using both small-signal and large-current ground traces, the two ground traces should be routed separately but connected to a single ground at the reference point of the application board to avoid fluctuations in the small-signal ground caused by large current. Also ensure that the ground traces of external components do not cause variation on the ground voltage. The ground lines must be as short and thick as possible to reduce line impedance.

5. Thermal Consideration

Should by any chance the power dissipation rating be exceeded, the rise in temperature of the chip may result in deterioration of the properties of the chip. The absolute maximum rating of the Pd stated in this specification is when the IC is mounted on a 70mm x 70mm x 1.6mm glass epoxy board. In case of exceeding this absolute maximum rating, increase the board size and copper area to prevent exceeding the Pd rating.

6. Recommended Operating Conditions

These conditions represent a range within which the expected characteristics of the IC can be approximately obtained. The electrical characteristics are guaranteed under the conditions of each parameter.

7. Inrush Current

When power is first supplied to the IC, it is possible that the internal logic may be unstable and inrush current may flow instantaneously due to the internal powering sequence and delays, especially if the IC has more than one power supply. Therefore, give special consideration to power coupling capacitance, power wiring, width of ground wiring, and routing of connections.

8. Operation Under Strong Electromagnetic Field

Operating the IC in the presence of a strong electromagnetic field may cause the IC to malfunction.

9. Testing on Application Boards

When testing the IC on an application board, connecting a capacitor directly to a low-impedance output pin may subject the IC to stress. Always discharge capacitors completely after each process or step. The IC's power supply should always be turned off completely before connecting or removing it from the test setup during the inspection process. To prevent damage from static discharge, ground the IC during assembly and use similar precautions during transport and storage.

10. Inter-pin Short and Mounting Errors

Ensure that the direction and position are correct when mounting the IC on the PCB. Incorrect mounting may result in damaging the IC. Avoid nearby pins being shorted to each other especially to ground, power supply and output pin. Inter-pin shorts could be due to many reasons such as metal particles, water droplets (in very humid environment) and unintentional solder bridge deposited in between pins during assembly to name a few.

11. Unused Input Terminals

Input terminals of an IC are often connected to the gate of a MOS transistor. The gate has extremely high impedance and extremely low capacitance. If left unconnected, the electric field from the outside can easily charge it. The small charge acquired in this way is enough to produce a significant effect on the conduction through the transistor and cause unexpected operation of the IC. So, unless otherwise specified, unused input terminals should be connected to the power supply of ground line.

Operational Notes – continued

12. Regarding the Input Pins of the IC

This monolithic IC contains P+ isolation and P substrate layers between adjacent elements in order to keep them isolated. P-N junctions are formed at the intersection of the P layers with the N layers of other elements, creating a parasitic diode or transistor. For example (refer to figure below):

When $GND > Pin A$ and $GND > Pin B$, the P-N junction operates as a parasitic diode.

When $GND > Pin B$, the P-N junction operates as a parasitic transistor.

Parasitic diodes inevitably occur in the structure of the IC. The operation of parasitic diodes can result in mutual interference among circuits, operational faults, or physical damage. Therefore, conditions that cause these diodes to operate, such as applying a voltage lower than the GND voltage to an input pin (and thus to the P substrate) should be avoided.

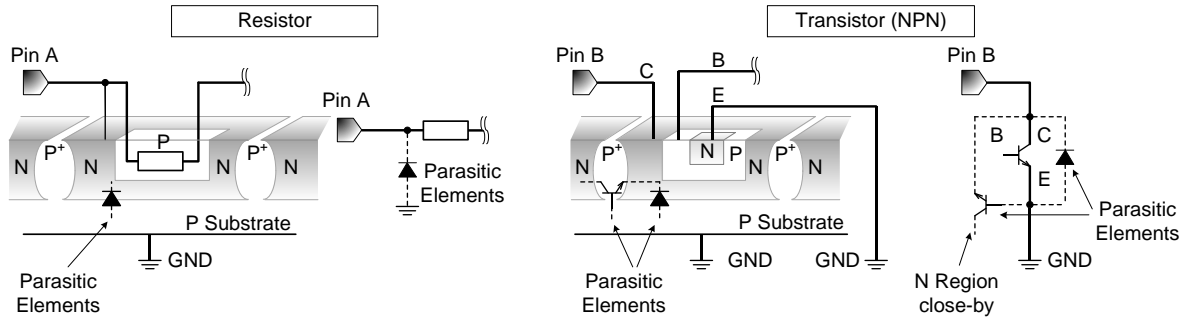

Figure 37. Example of monolithic IC structure

13. Thermal Shutdown Circuit (TSD)

This IC has a built-in thermal shutdown circuit that prevents heat damage to the IC. Normal operation should always be within the IC's power dissipation rating. If however the rating is exceeded for a continued period, the junction temperature (T_j) will rise which will activate the TSD circuit that will turn OFF all output pins. When the T_j falls below the TSD threshold, the circuits are automatically restored to normal operation.

Note that the TSD circuit operates in a situation that exceeds the absolute maximum ratings and therefore, under no circumstances, should the TSD circuit be used in a set design or for any purpose other than protecting the IC from heat damage.

14. Thermal Consideration

Use a thermal design that allows for a sufficient margin by taking into account the permissible power dissipation (P_d) in actual operating conditions.

15. Capacitor between Logic Output and GND

The logic outputs are VBUSOK, PGOOD, ISETOUT1 and ISETOUT2. With a large capacitor connected between logic output and GND, it is possible that the logic output will short to 0V or GND and will cause the current from the capacitor to flow into the logic output, causing damage to IC. The capacitor between logic output and GND must be 0.1 μ F or less.

Ordering Information

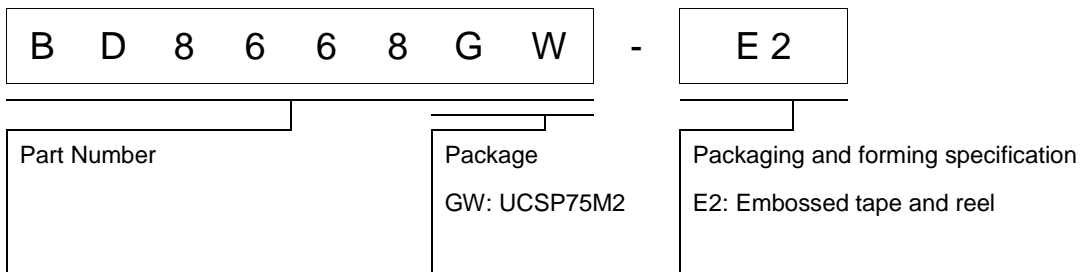

Marking Diagrams

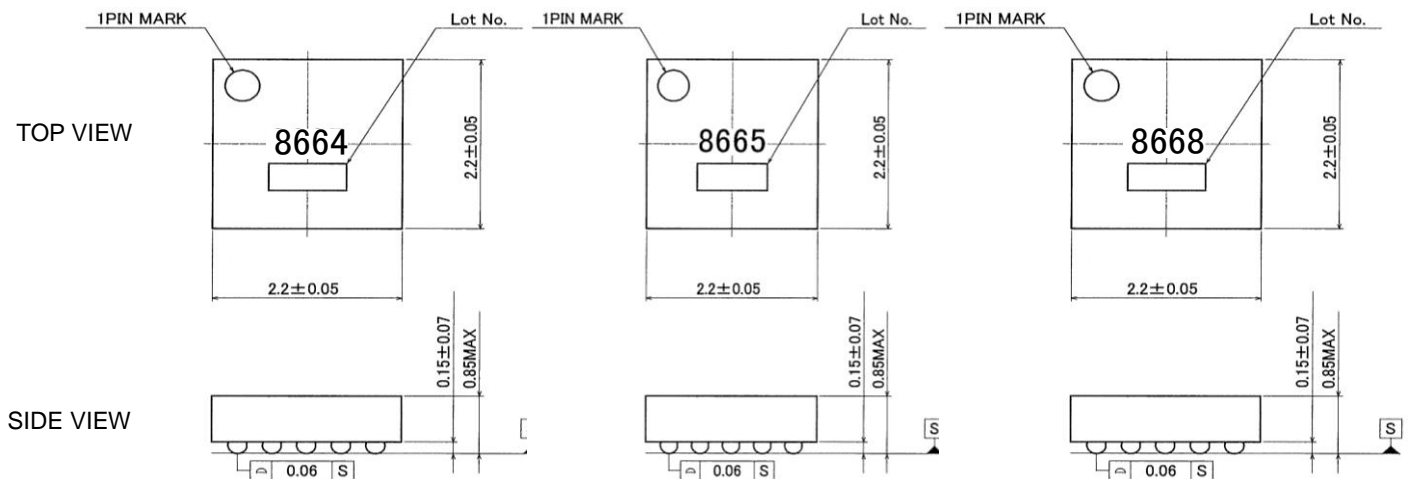

Part Number Marking	Package	Orderable Part Number
BD8664GW	UCSP75M2	BD8664GW-E2
BD8665GW	UCSP75M2	BD8665GW-E2
BD8668GW	UCSP75M2	BD8668GW-E2

Physical Dimensions, Tape and Reel information

Package Name	UCSP75M2 (BD8664GW)
--------------	-----------------------

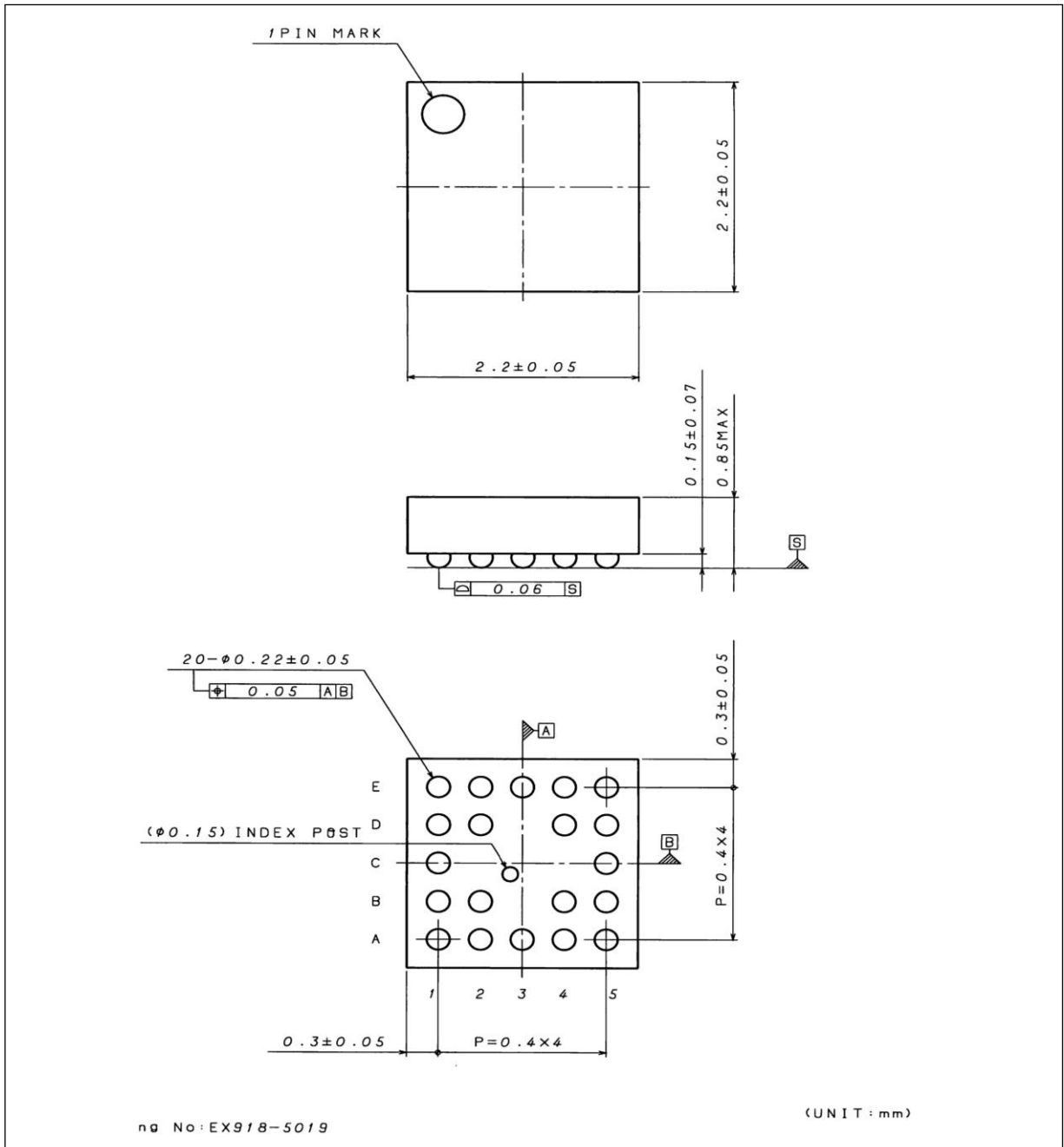

< Tape and Reel Information >

Tape	Embossed carrier tape
Quantity	3000pcs
Direction of feed	E2 The direction is the pin 1 of product is at the upper left when you hold reel on the left hand and you pull out the tape on the right hand

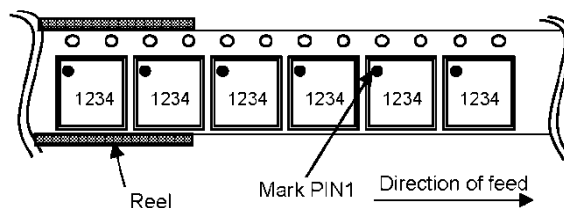

Physical Dimensions, Tape and Reel information

Package Name	UCSP75M2 (BD8668GW)
--------------	-----------------------

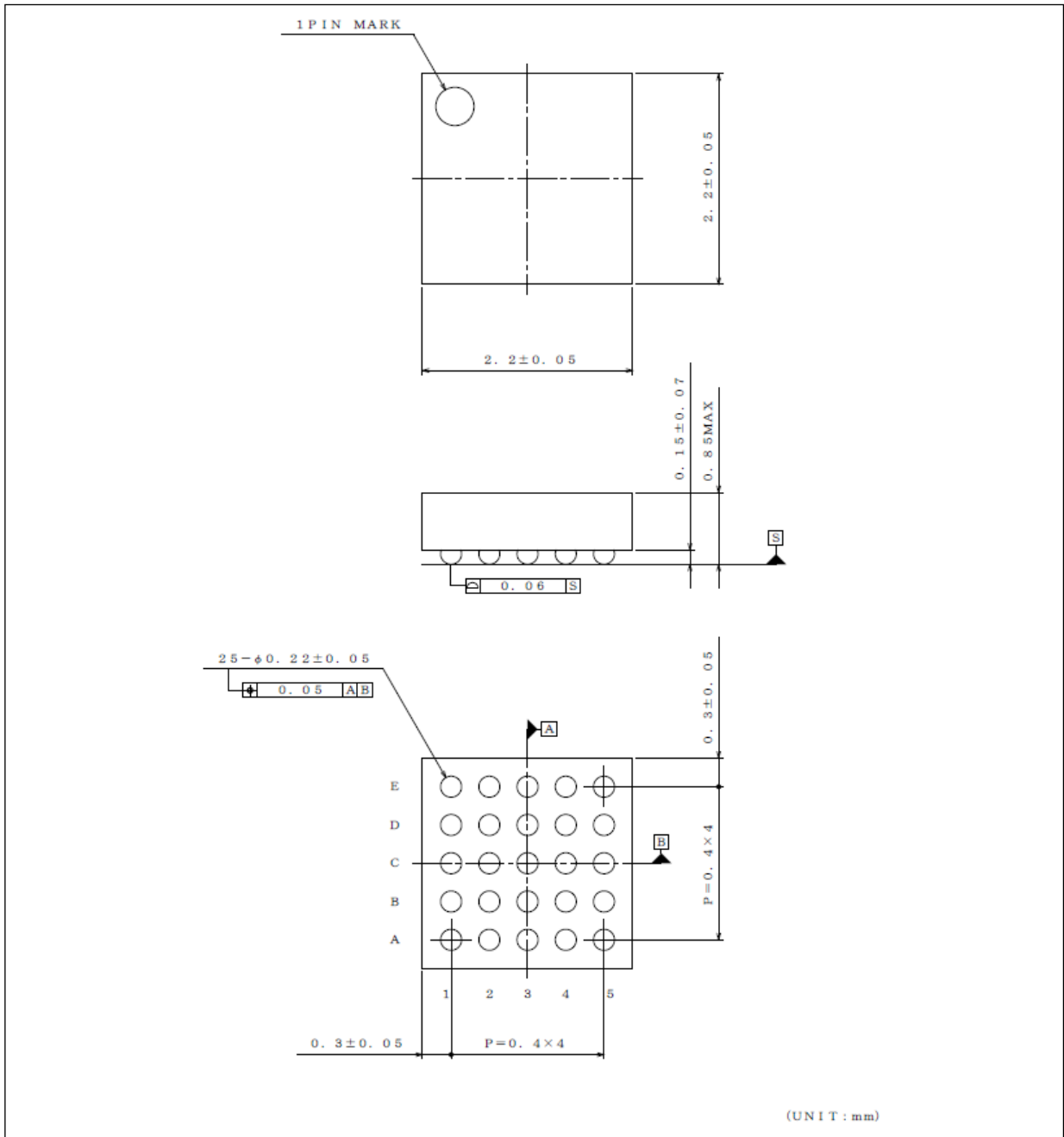

< Tape and Reel Information >

Tape	Embossed carrier tape
Quantity	3000pcs
Direction of feed	E2 The direction is the pin 1 of product is at the upper left when you hold reel on the left hand and you pull out the tape on the right hand

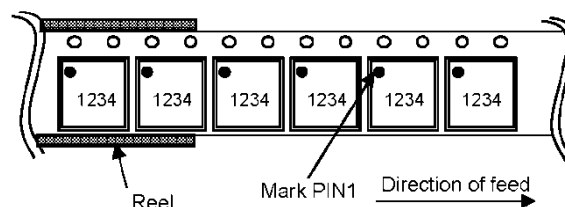

Revision History

Date	Revision	Changes
17.Dec.2014	001	New Release
7.Jul.2015	002	Condition of OCP is added in PGOOD function explanation.(pp16-17)

Notice

Precaution on using ROHM Products

- Our Products are designed and manufactured for application in ordinary electronic equipments (such as AV equipment, OA equipment, telecommunication equipment, home electronic appliances, amusement equipment, etc.). If you intend to use our Products in devices requiring extremely high reliability (such as medical equipment ^(Note 1), transport equipment, traffic equipment, aircraft/spacecraft, nuclear power controllers, fuel controllers, car equipment including car accessories, safety devices, etc.) and whose malfunction or failure may cause loss of human life, bodily injury or serious damage to property ("Specific Applications"), please consult with the ROHM sales representative in advance. Unless otherwise agreed in writing by ROHM in advance, ROHM shall not be in any way responsible or liable for any damages, expenses or losses incurred by you or third parties arising from the use of any ROHM's Products for Specific Applications.

(Note1) Medical Equipment Classification of the Specific Applications

JAPAN	USA	EU	CHINA
CLASS III	CLASS III	CLASS II b	CLASS III
CLASS IV		CLASS III	

- ROHM designs and manufactures its Products subject to strict quality control system. However, semiconductor products can fail or malfunction at a certain rate. Please be sure to implement, at your own responsibilities, adequate safety measures including but not limited to fail-safe design against the physical injury, damage to any property, which a failure or malfunction of our Products may cause. The following are examples of safety measures:
 - Installation of protection circuits or other protective devices to improve system safety
 - Installation of redundant circuits to reduce the impact of single or multiple circuit failure
- Our Products are designed and manufactured for use under standard conditions and not under any special or extraordinary environments or conditions, as exemplified below. Accordingly, ROHM shall not be in any way responsible or liable for any damages, expenses or losses arising from the use of any ROHM's Products under any special or extraordinary environments or conditions. If you intend to use our Products under any special or extraordinary environments or conditions (as exemplified below), your independent verification and confirmation of product performance, reliability, etc. prior to use, must be necessary:
 - Use of our Products in any types of liquid, including water, oils, chemicals, and organic solvents
 - Use of our Products outdoors or in places where the Products are exposed to direct sunlight or dust
 - Use of our Products in places where the Products are exposed to sea wind or corrosive gases, including Cl₂, H₂S, NH₃, SO₂, and NO₂
 - Use of our Products in places where the Products are exposed to static electricity or electromagnetic waves
 - Use of our Products in proximity to heat-producing components, plastic cords, or other flammable items
 - Sealing or coating our Products with resin or other coating materials
 - Use of our Products without cleaning residue of flux (even if you use no-clean type fluxes, cleaning residue of flux is recommended); or Washing our Products by using water or water-soluble cleaning agents for cleaning residue after soldering
 - Use of the Products in places subject to dew condensation
- The Products are not subject to radiation-proof design.
- Please verify and confirm characteristics of the final or mounted products in using the Products.
- In particular, if a transient load (a large amount of load applied in a short period of time, such as pulse. is applied, confirmation of performance characteristics after on-board mounting is strongly recommended. Avoid applying power exceeding normal rated power; exceeding the power rating under steady-state loading condition may negatively affect product performance and reliability.
- De-rate Power Dissipation (Pd) depending on Ambient temperature (Ta). When used in sealed area, confirm the actual ambient temperature.
- Confirm that operation temperature is within the specified range described in the product specification.
- ROHM shall not be in any way responsible or liable for failure induced under deviant condition from what is defined in this document.

Precaution for Mounting / Circuit board design

- When a highly active halogenous (chlorine, bromine, etc.) flux is used, the residue of flux may negatively affect product performance and reliability.
- In principle, the reflow soldering method must be used on a surface-mount products, the flow soldering method must be used on a through hole mount products. If the flow soldering method is preferred on a surface-mount products, please consult with the ROHM representative in advance.

For details, please refer to ROHM Mounting specification

Precautions Regarding Application Examples and External Circuits

1. If change is made to the constant of an external circuit, please allow a sufficient margin considering variations of the characteristics of the Products and external components, including transient characteristics, as well as static characteristics.
2. You agree that application notes, reference designs, and associated data and information contained in this document are presented only as guidance for Products use. Therefore, in case you use such information, you are solely responsible for it and you must exercise your own independent verification and judgment in the use of such information contained in this document. ROHM shall not be in any way responsible or liable for any damages, expenses or losses incurred by you or third parties arising from the use of such information.

Precaution for Electrostatic

This Product is electrostatic sensitive product, which may be damaged due to electrostatic discharge. Please take proper caution in your manufacturing process and storage so that voltage exceeding the Products maximum rating will not be applied to Products. Please take special care under dry condition (e.g. Grounding of human body / equipment / solder iron, isolation from charged objects, setting of Ionizer, friction prevention and temperature / humidity control).

Precaution for Storage / Transportation

1. Product performance and soldered connections may deteriorate if the Products are stored in the places where:
 - [a] the Products are exposed to sea winds or corrosive gases, including Cl₂, H₂S, NH₃, SO₂, and NO₂
 - [b] the temperature or humidity exceeds those recommended by ROHM
 - [c] the Products are exposed to direct sunshine or condensation
 - [d] the Products are exposed to high Electrostatic
2. Even under ROHM recommended storage condition, solderability of products out of recommended storage time period may be degraded. It is strongly recommended to confirm solderability before using Products of which storage time is exceeding the recommended storage time period.
3. Store / transport cartons in the correct direction, which is indicated on a carton with a symbol. Otherwise bent leads may occur due to excessive stress applied when dropping of a carton.
4. Use Products within the specified time after opening a humidity barrier bag. Baking is required before using Products of which storage time is exceeding the recommended storage time period.

Precaution for Product Label

QR code printed on ROHM Products label is for ROHM's internal use only.

Precaution for Disposition

When disposing Products please dispose them properly using an authorized industry waste company.

Precaution for Foreign Exchange and Foreign Trade act

Since concerned goods might be fallen under listed items of export control prescribed by Foreign exchange and Foreign trade act, please consult with ROHM in case of export.

Precaution Regarding Intellectual Property Rights

1. All information and data including but not limited to application example contained in this document is for reference only. ROHM does not warrant that foregoing information or data will not infringe any intellectual property rights or any other rights of any third party regarding such information or data.
2. ROHM shall not have any obligations where the claims, actions or demands arising from the combination of the Products with other articles such as components, circuits, systems or external equipment (including software).
3. No license, expressly or implied, is granted hereby under any intellectual property rights or other rights of ROHM or any third parties with respect to the Products or the information contained in this document. Provided, however, that ROHM will not assert its intellectual property rights or other rights against you or your customers to the extent necessary to manufacture or sell products containing the Products, subject to the terms and conditions herein.

Other Precaution



1. This document may not be reprinted or reproduced, in whole or in part, without prior written consent of ROHM.
2. The Products may not be disassembled, converted, modified, reproduced or otherwise changed without prior written consent of ROHM.
3. In no event shall you use in any way whatsoever the Products and the related technical information contained in the Products or this document for any military purposes, including but not limited to, the development of mass-destruction weapons.
4. The proper names of companies or products described in this document are trademarks or registered trademarks of ROHM, its affiliated companies or third parties.

General Precaution







1. Before you use our Products, you are requested to carefully read this document and fully understand its contents. ROHM shall not be in any way responsible or liable for failure, malfunction or accident arising from the use of any ROHM's Products against warning, caution or note contained in this document.
2. All information contained in this document is current as of the issuing date and subject to change without any prior notice. Before purchasing or using ROHM's Products, please confirm the latest information with a ROHM sales representative.
3. The information contained in this document is provided on an "as is" basis and ROHM does not warrant that all information contained in this document is accurate and/or error-free. ROHM shall not be in any way responsible or liable for any damages, expenses or losses incurred by you or third parties resulting from inaccuracy or errors of or concerning such information.

Looking for pricing, stock, or lifecycle information?

Click below to explore more details on WIN SOURCE:

-  [View BD8665GW-E2 on WIN SOURCE](#)
-  [Rohm Semiconductor](#) Information

Optimize Your Supply Chain with WIN SOURCE Solutions

-  Global Sourcing Solution
-  Obsolete Management
-  Cost Control Management
-  Shortage Management
-  Alternative Solution
-  Excess Inventory Management