



**THE DATASHEET OF
B30931D7020Y918**





Complementary wireless module WLAN / BT

Standard Laminate SiP Module

Series/Type: R078 (WL1837) / D7020
Ordering code: B30931D7020Y918
Date: 2014-12-9
Version: 1.3

1. Overview

This document details the specifications and features of R078 (WL1837) / D7020 SiP module. The R078 (WL1837) / D7020 SiP module is based on Texas Instruments WL1837 IC, specifically WL183x Data Sheet version 1.4, such that the SiP module specification is subject to any subsequent changes in applicable Texas Instruments documentation and software.

The R078 (WL1837) / D7020 contains the WL1837 SoC, 2.4GHz and 5 GHz SPDT switches, 2.4GHz and 5GHz band pass filters / diplexer and necessary passive components for WLAN and BT in a highly integrated solution.

1.1 Features

- WLAN, BT, BLE on a single chip provide universal connectivity in small PCB footprint.
- Provides efficient direct connection to battery by employing several integrated switched mode power supplies (DC2DC).
- Based on 45nm CMOS technology using proven core technology.
- Seamless integration with TI OMAP™ Application Processors.
- WLAN and Bluetooth cores software and hardware are compatible with prior WL127x and WL128x offerings, for smooth migration to Device.
- Shared HCI transport for BT/BLE over UART and SDIO for WLAN.
- Downloadable patches and firmware enables new features to be added for all functional block's.
- Temperature detection and compensation mechanism ensures minimal variation in the RF performance over the entire temperature range.
- Bluetooth 4.0, BLE and all audio processing features work in parallel and include full coexistence with WLAN

1.2 Applications

Mobile phone and mobile computer device applications.

1.3 General Description

The R078 (WL1837) / D7020 is a highly integrated WLAN, BT, BLE device that forms a complete standalone communication system. The WL1837 is a highly integrated single-chip CMOS (45-nm process) incorporates the core functionality of the WL1271/3 and WL1281/3 devices.

The device is the 8th-generation WLAN/BT/BLE devices from Texas Instruments. As such, the WL1837 is based upon proven core technology and complements the TI integrated devices for connectivity portfolio.

R078 (WL1837) / D7020 is ideal for use in mobile phone and mobile computer device applications due to its low current, small area and cellular phone coexistence-friendly features.

1.4 Terms and abbreviations

BPF – Band-Pass Filter

BT – Bluetooth

FE – Front-End (refers to FE IC and BPF)

GND – Ground

HCI – Host Controller Interface

IC – Integrated Circuit

I/O – Input/Output interfaces

LDO – Low Drop-Out (voltage regulator)

PCB – Printed Circuit Board

Q – Quality factor

RF – Radio Frequency

RX – Receive

SiP – System in Package

SoC – System on Chip

TX – Transmit

Vbat – Battery Voltage

VIO – external pre-existing 1.8V IO power supply

WLAN – Wireless Local Area Network

1.5 Reference documents

- Texas Instruments WL183x_Data_Manual_Rev_1_4.pdf

1. OVERVIEW	2
1.1 FEATURES	2
1.2 APPLICATIONS.....	2
1.3 GENERAL DESCRIPTION	2
1.4 TERMS AND ABBREVIATIONS.....	3
1.5 REFERENCE DOCUMENTS	3
2 FUNCTIONAL BLOCK FEATURES	5
2.1 FUNCTIONAL BLOCK DIAGRAM	5
2.2 WLAN FEATURES	6
2.3 BLUETOOTH FEATURES.....	6
2.4 BLE FEATURES	6
3 DETAILED DESCRIPTION	7
3.1 HOST INTERFACES.....	7
3.2 CLOCKS AND POWER MANAGEMENT	11
3.3 WLAN FUNCTIONAL BLOCK	14
3.4 BLUETOOTH FUNCTIONAL BLOCK	16
3.5 TERMINAL ASSIGNMENTS	18
3.6 TERMINAL FUNCTIONS.....	19
4 DESIGN GOAL SPECIFICATIONS.....	25
4.1 GENERAL CHIP REQUIREMENTS AND OPERATION.....	25
4.2 WLAN RF PERFORMANCE	28
4.3 BLUETOOTH RF PERFORMANCE.....	32
4.4 BLE RF PERFORMANCE	36
4.5 INTERFACE TIMING CHARACTERISTICS	38
4.6 PACKAGE MECHANICAL DRAWING.....	42
4.7 SCHEMATIC	43
5 LEAD-FREE PRODUCT STATUS	44
6 RECOMMENDED REFLOW PROFILE	45
7 PACKING INFORMATION	46
8 REVISION HISTORY.....	49
DISPLAY OF ORDERING CODES FOR EPCOS PRODUCTS	50

2 Functional Block Features

2.1 Functional Block Diagram

Figure 2-1 shows a high-level view of R078 (WL1837) / D7020 along with its various configurations. The flexibility of the R078 (WL1837) / D7020 based on WL1837 enables easy integration with various host-system topologies.

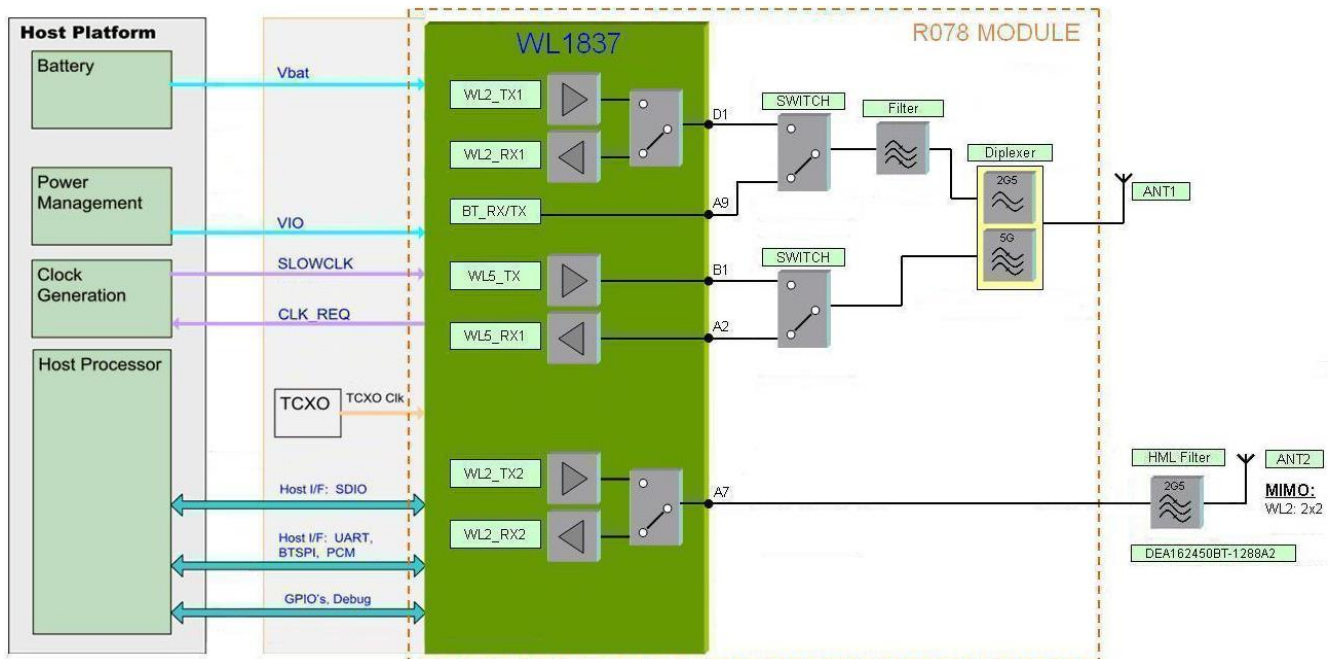

Figure 2-1 High-Level System Diagram

2.2 WLAN Features

- Integrated 2.4 & 5GHz power amplifiers for complete WLAN solution
- WLAN MAC Baseband Processor and RF transceiver - IEEE802.11a/b/g/n compliant
- WLAN 2.4 / 5 GHz SISO (20 / 40 MHz channels), 2.4 GHz MIMO (20 MHz channels).
- Baseband Processor
 - IEEE Std 802.11a/b/g data rates and IEEE Std 802.11n data rates with 20 or 40 MHz SISO and 20 MHz MIMO.
- Fully calibrated system. No production calibration required.
- Medium-Access Controller (MAC)
 - Embedded ARM™ Central Processing Unit (CPU)
 - Hardware-Based Encryption/Decryption Using 64-, 128-, and 256-Bit WEP, TKIP or AES Keys,
 - Supports requirements for Wi-Fi Protected Access (WPA and WPA2.0) and IEEE Std 802.11i [Includes Hardware-Accelerated Advanced-Encryption Standard (AES)]
 - Designed to work with IEEE Std 802.1x
- New advanced co-existence scheme with BT/BLE
- 2.4/5.0 GHz Radio
 - Internal LNA, PA and RF switch
 - Supports: IEEE Std 802.11a, 802.11b, 802.11g and 802.11n
- Supports 4 bit SDIO host interface, including high speed (HS) and V3 modes

2.3 Bluetooth Features

- Supports Bluetooth 4.0 BLE
- Includes concurrent operation and built-in coexistence and prioritization handling of BT, BLE, audio processing and WLAN
- Dedicated Audio processor supporting on chip SBC encoding + A2DP:
 - Assisted A2DP (A3DP) support - SBC Encoding implemented internally
 - Assisted WB-Speech (AWBS) support - modified SBC codec implemented internally

2.4 BLE Features

- Fully compliant with BT4.0 BLE dual mode standard
- Support for all roles and role-combinations, mandatory as well as optional
- Supports up to 10BLE connection
- Independent buffering for LE allows having large number of multiple connections without affecting BR/EDR performance

3 Detailed Description

3.1 Host Interfaces

3.1.1 Device Host Interface Options

The following table summarizes the Host Controller interface options. All interfaces operate independently.

Table 3-1 Host Controller Interface options

WLAN	Shared HCI for BT	BT Voice/Audio
WLAN HS SDIO	Over UART	BT PCM

The Device incorporates UART module dedicated to the BT shared-transport Host Controller Interface (HCI) transport layer. The HCI interface is used to transport commands, events, and ACL between the Bluetooth device and its host using HCI data packets.

This acts as a shared transport for BT/BLE functional blocks.

3.1.2 WLAN SDIO Transport Layer

The SDIO is the host interface for WLAN. The interface between the host and the D7020 uses an SDIO interface and supports a maximum clock rate of 50MHz.

The Device SDIO also supports the following features of the SDIO V3 specification:

- 4 bit data bus
- Synchronous and Asynchronous In-Band-Interrupt
- Default and High-Speed (50MHz) timing
- Sleep/wake commands

SDIO timing specifications are given in specification section at end of document.

3.1.3 HCI UART Shared Transport Layers for BT

The HCI UART supports most baud rates (including all PC rates) for all fast clock frequencies - up to maximum of 4 Mbps. After power up the baud rate is set for 115.2 kbps, irrespective of fast clock frequency. The baud rate can then be changed by using a VS command. The Device responds with a Command Complete Event (still at 115.2 kbps), after which the baud rate change takes place.

HCI hardware includes the following features:

- Receiver detection of break, idle, framing, FIFO overflow, and parity error conditions.
- Transmitter underflow detection.
- CTS/RTS hardware flow control.
- 4 wire (H4)

Parameter	Value
<i>Bit rate</i>	<i>115.2 kbps</i>
Data length	8 bits
Stop bit	1
Parity	None

Table 3-2 UART Default Setting

3.1.3.1 UART 4 Wire Interface - H4

The interface includes four signals: TXD, RXD, CTS and RTS. Flow control between the host and the Device is byte-wise by hardware.

Flow control is obtained by the following:

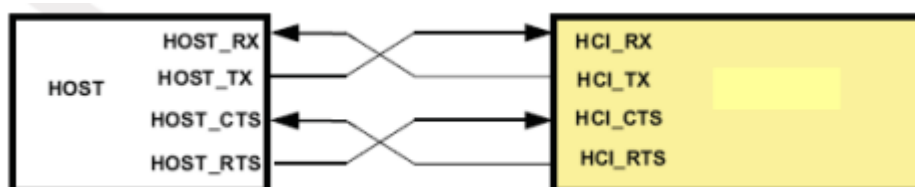

Figure 3-1 H4I UART Connection

When the RX buffer of the Device passes the “flow control” threshold, it will set the H4I_RTS signal high to stop transmission from the host.

When the CTS signal is set high, the Device will stop its transmission on the interface. In case CTS is set high in the middle of transmitting a byte, the Device will finish transmitting the byte and stop the transmission.

3.1.3.2 BT function Firmware Low Power Mode Protocols

The Device includes a mechanism that handles the transition between operating mode and deep sleep low-power mode. The protocol is done via the UART and is known as eHCILL (enhanced HCI Low Level) power management protocol.

This protocol is backward compatible with the TI BT HCILL Protocol, so a Host that implements the HCILL does not need to change anything in order to work with the Device. The "Enhanced" portion of the HCILL introduces changes that allow a simpler host implementation of this protocol. See SWRA288 eHCILL Four-Wire Power Management Protocol.

3.1.4 BT Audio CODEC Interface

3.1.4.1 Overview

The CODEC interface is a fully dedicated programmable serial port, supporting the following:

- Two voice channels
- Master / slave modes
- Coding schemes: u-Law, A-Law, Linear, Transparent and SBC (for Assisted WBS operation)
- Long & short frames
- Different data sizes, order and positions
- Enlarged interface options to support a wider variety of Codecs

3.1.4.2 PCM Hardware Interface

The PCM interface is one implementation of the codec interface. It contains the following four lines:

- Clock--configurable direction (input or output)
- Frame Sync--configurable direction (input or output)
- Data In--Input
- Data Out--Output/Tri state

The Device can be either the master of the interface where it generates the clock and the frame-sync signals, or slave where it receives these two signals. The PCM interface is fully configured by means of a VS command.

For slave mode, clock input frequencies between 64KHz and 12 MHz are supported..

For master mode, the Device can generate any clock frequency between 64 kHz and 6 MHz.

3.1.4.3 PCM Data Format

The data format is fully configurable:

- The data length can be from 8 to 320 bits, in 1 bit increments, when working with two channels, or up to 640 bits when using 1 channel. The data length can be set independently for each channel.
- The data position within a frame is also configurable with 1-clock (bit) resolution, and can be set independently (relative to the edge of the Frame Sync signal) for each channel.
- The Data_IN and Data_OUT bit order can be configured independently. For example; Data_IN can start with MSB while Data_OUT starts with LSB. Each channel is separately configurable. The inverse bit order (i.e. LSB first) is supported only for sample sizes up to 24 bits.
- The data in and data out size do not necessarily have to be the same length.
- The Data_OUT line is configured as a „high-Z“ output between data words. Data_OUT can also be set for permanent high-Z, irrespective of data out. This allows the Device to be a bus slave in a multi-slave PCM environment. At power up, Data_OUT is configured as high-Z.

3.1.4.4 PCM Frame-Idle Period

The CODEC interface has the capability for frame-idle periods, where the PCM clock can “take a break” and become ‘0’ at the end of the PCM frame, after all data has been transferred.

The Device supports frame-idle periods both as master and slave of the PCM bus.

When Device is the master of the interface, the frame-idle period is configurable. There are 2 configurable parameters:

- Clk_Idle_Start - Indicates the number of PCM clock cycles from the beginning of the frame till the beginning of the idle period. After Clk_Idle_Start clock cycles, the clock becomes ‘0’.
- Clk_Idle_End - Indicates the time from the beginning of the frame till the end of the idle period. This time is given in multiples of PCM clock periods.

The delta between Clk_Idle_Start and Clk_Idle_End is the clock idle period.

e.g. For PCM clock rate = 1 MHz, frame sync period = 10 kHz, Clk_Idle_Start = 60, Clk_Idle_End = 90.

Between each two-frame sync there are 70 clock cycles (instead of 100). The clock idle period starts 60 clock cycles after the beginning of the frame and lasts $90-60=30$ clock cycles. This means that the idle period ends $100-90=10$ clock cycles before the end of the frame. The data transmission must end prior to the beginning of the idle period.

3.1.5 Two Channel PCM Bus Example

In the following figure, a 2-channel PCM bus is shown where the two channels have different word sizes and arbitrary positions in the bus' frame. (FT stands for Frame Timer).

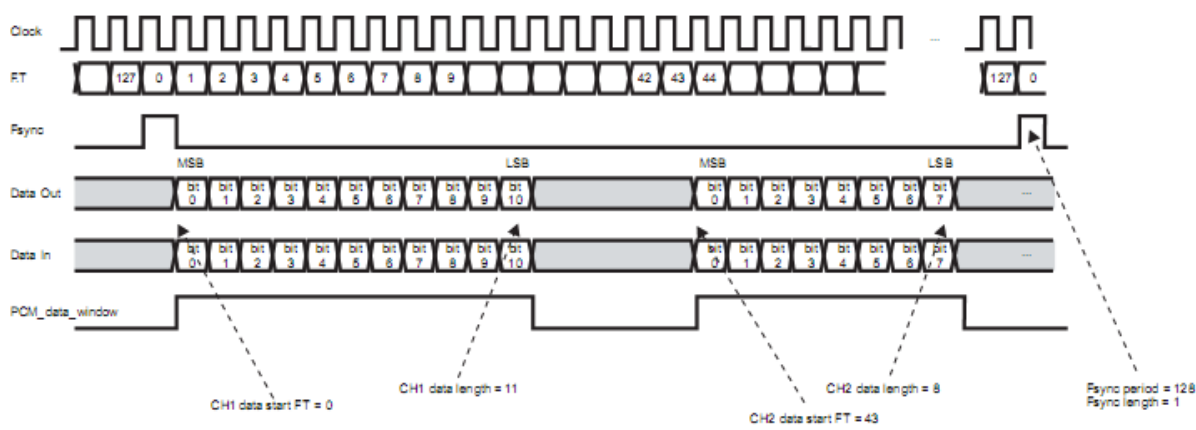

Figure 3-2 2 Channels PCM Bus Timing

3.1.6 PCM Audio Encoding

The Device CODEC interface can use one of four audio coding patterns:

- A-Law (8-bit)
- μ -Law (8-bit)
- Linear (8 or 16-bit)
- SBC (16-bit)

Two BT voice channels are not supported when SBC encoding is selected.

3.1.6.1 BT PCM Clock Mismatch Handling

In BT RX, the Device receives RF voice packets and writes these to the CODEC I/F. If the Device receives data faster than the CODEC I/F output allows, an overflow occurs. In this case, the Device BT function has 2 possible behavior modes: "allow overflow" and "don't allow overflow".

- If overflow is allowed, the Device BT function continues receiving data and overwrites any data not yet sent to the CODEC.
- If overflow is not allowed, RF voice packets received when buffer is full, are discarded.

When the Bluetooth functional block is master on the PCM and slave on the Bluetooth network, the Bluetooth functional block can measure the drift between the two clocks and apply compensation to the PCM clock in order to avoid underrun and overrun scenarios

3.1.6.2 BT Inter-IC Sound (BT I2S over PCM bus)

The Device can be configured as an Inter-IC Sound (I2S) serial interface to a I2S CODEC device. In this mode, the Device audio CODEC interface is configured as a bi-directional, full duplex interface, with two time slots per frame: Time slot 0 is used for the left channel audio data and time slot 1 for the right channel audio data. Each time slot is configurable up to 40 serial clock cycles in length and the frame is configurable up to 80 serial clock cycles in length.

3.2 Clocks and Power Management

3.2.1 Slow Clock / RTC clock

The slow clock is a free-running clock of 32.768 KHz which is supplied from an external clock source. It is connected to the RTC_CLK pin and is a digital square-wave signal in the range of 0-1.8V nom.

3.2.2 Fast Clock System

3.2.2.1 Fast clock using external crystal

The devices incorporate an internal crystal oscillator circuit for supporting a cost optimized crystal based fast clock scheme. Connection is as shown:

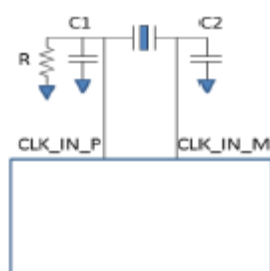

Figure 3-3 XTAL Connection

C1 = C2. Typically 8 - 22pF. Refer to Crystal manufacturer's recommendations.

R = 390K ohm (+/- 5% tolerance).

NOTE : this arrangement does not support 5GHz band functions.

3.2.2.2 Fast Clock using external oscillator

CLK_IN_P is the main system fast clock and must meet the specifications as described in "Fast clock specifications" at the end of this document.

The clock must be one of the specified frequencies and the device incorporates an internal mechanism to detect this. The clock can be AC or DC coupled, sine or square wave.

Crystal operation is supported as shown:

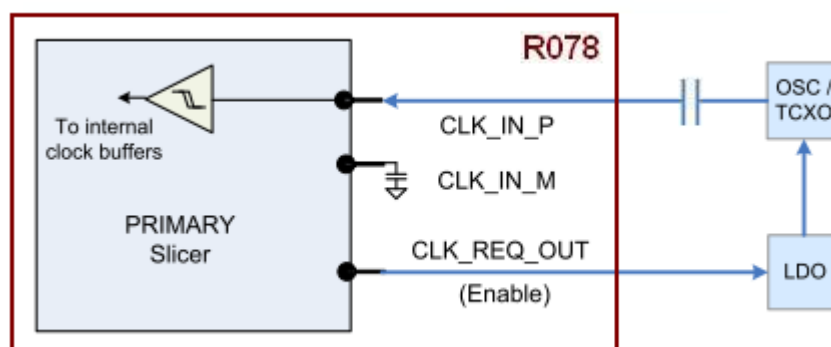

Figure 3-4 Fast Clock Block Diagram

3.2.3 Power Management

3.2.3.1 Block Diagram - internal DC2DC's

The Device incorporates three internal DC2DC's (switched-mode power supplies) to provide efficient internal and external supplies, derived from Vbat.

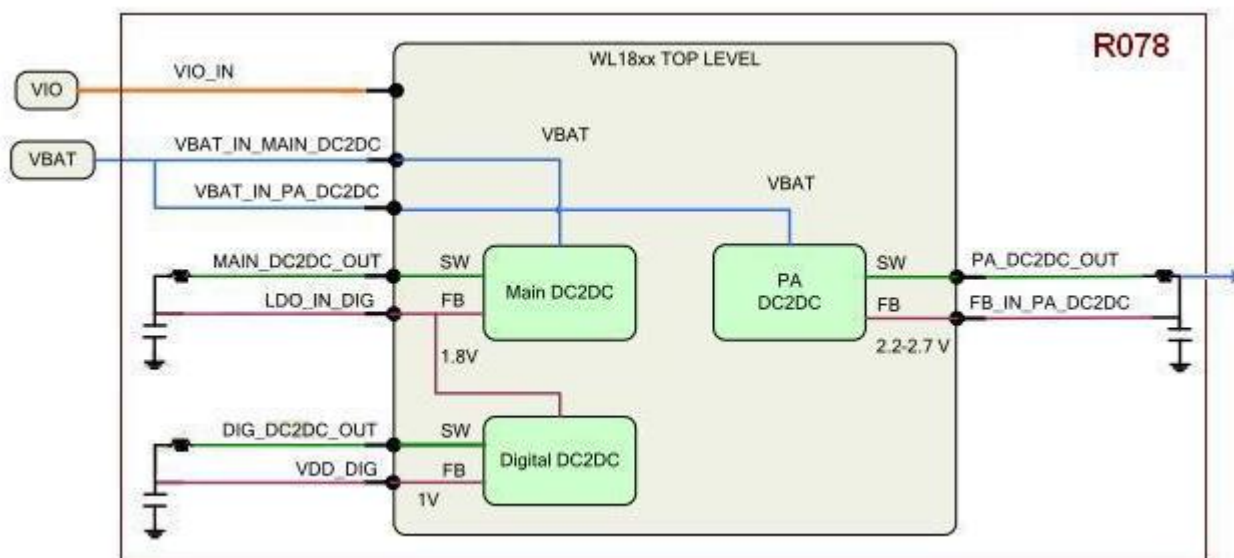

Figure 3-5 Internal DC2DC's

3.2.4 Reset / Power up system

After Vbat and VIO are fed to Device and while BT_EN, WLAN_EN are de-asserted (LOW), the device is in Shutdown state.

While in Shutdown state all functional blocks, internal DC2DC's and LDO's will be disabled. The power supplied to the functional blocks is cut off.

When one of the two signals BT_EN or WLAN_EN are asserted (High) a Power On Reset (POR) is performed. Stable Slow Clock, VIO and Vbat are pre-requisites for successful POR.

3.2.4.1 Chip Top-level Power Up Sequence

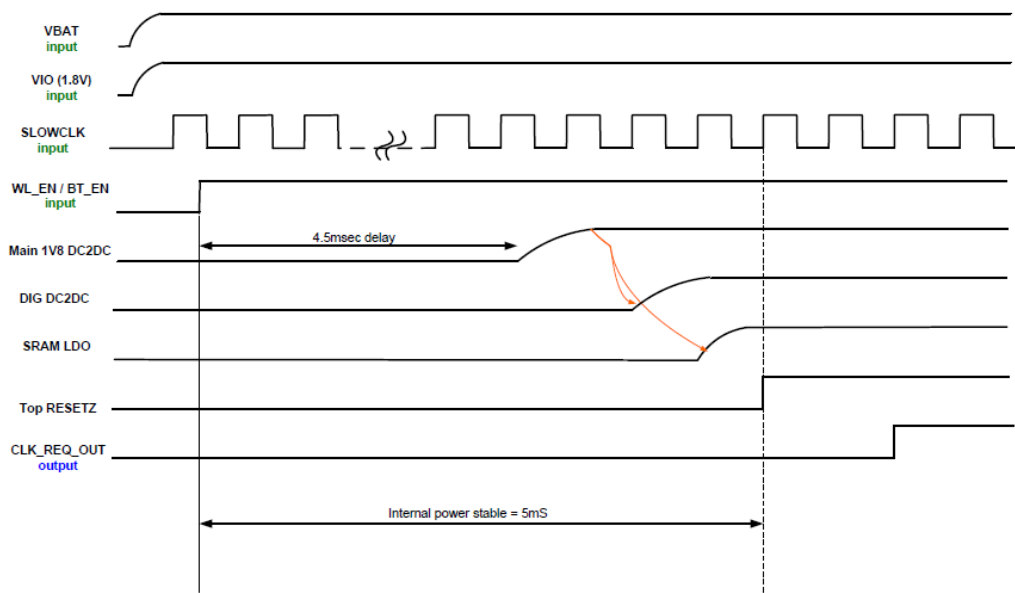

Figure 3-6 Chip Top-level Power Up Sequence

3.2.4.2 WLAN Power Up Sequence

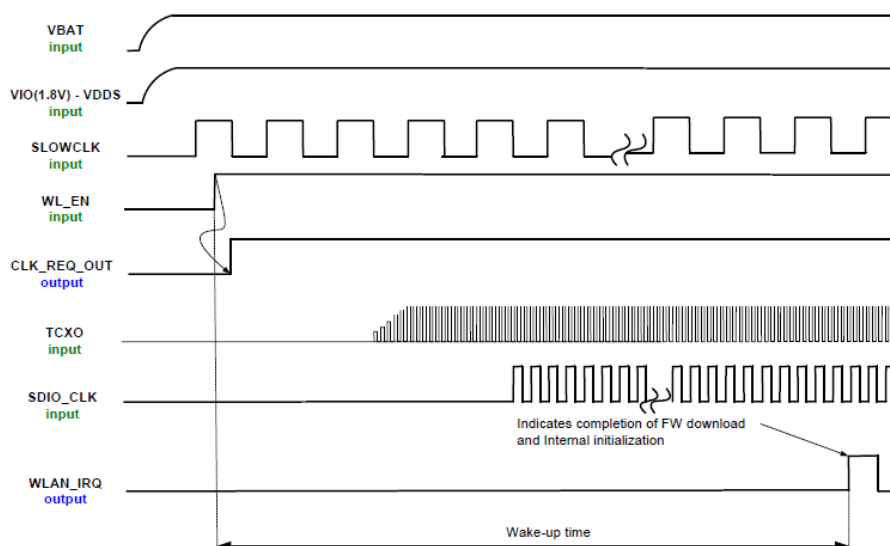

Figure 3-7 WLAN Power Up Sequence

3.2.4.3 BT/BLE Power Up Sequence

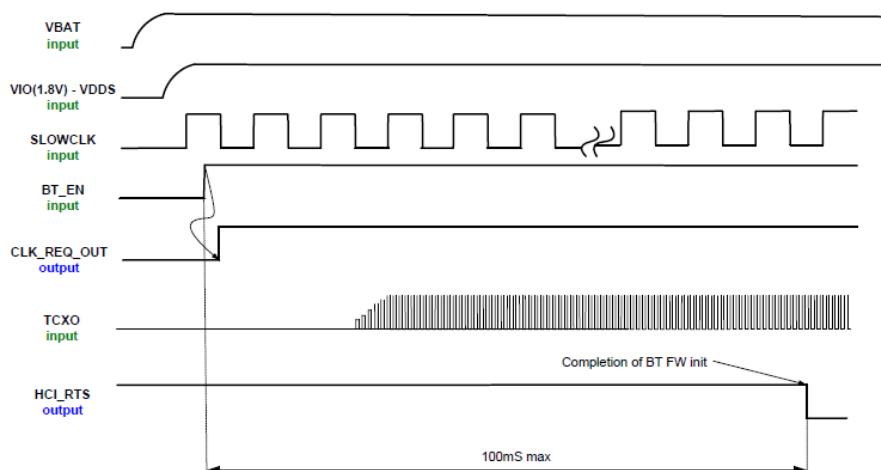

Figure 3-8 BT Power Up Sequence

3.3 WLAN Functional Block

3.3.1 WLAN MAC

R078 (WL1837) / D7020 MAC implements the IEEE standard 802.11 MAC sub-layer using both dedicated hardware and embedded firmware. The MAC hardware implements real-time functions, including access protocol management, encryption and decryption.

3.3.2 WLAN Baseband Processor

R078 (WL1837) / D7020 baseband processor implements the IEEE 802.11a/b/g/n PHY sub layers and has been optimized to perform well in conditions of high multipath and noise.

3.3.3 WLAN RF Radio

R078 (WL1837) / D7020 WLAN radio is a highly integrated radio processor designed for 802.11a/b/g/n applications, including internal front-end PA's.

3.3.4 Coexistence BT/BLE - WLAN

R078 (WL1837) / D7020 has been designed to support simultaneous operation of each of the major on-chip core functions. This operational coexistence is based on extensive frequency planning for each of the on-chip core functions, as well as a sophisticated MAC co-ordination scheme between Bluetooth and WLAN subsystems that allows operation in the same ISM frequency band.

3.3.5 WLAN RF Configuration and Power Options

The R078 (WL1837) / D7020 includes all RF switches, band pass filters and diplexer for complete WLAN (SISO) and BT RF system. Optional MIMO configuration is also supported with external band pass filter.

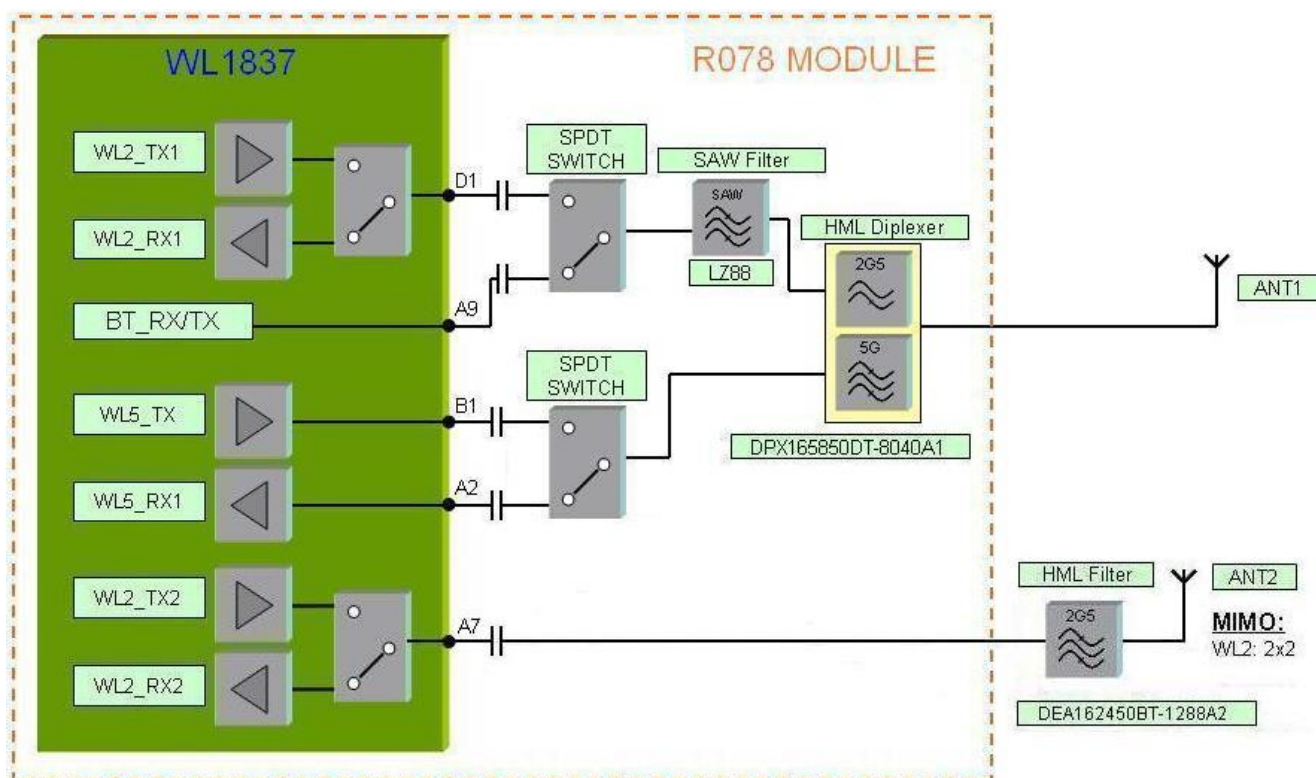

Figure 3-9 R078 (WL1837) / D7020 SISO/MIMO configuration options

3.3.5.1 MIMO and SISO options (WL1837 device)

The diagram above shows WLAN and BT pins in standard SISO application and also for optional MIMO.

Standard configuration for SISO:

- WLAN 2.4/5GHz + BT
- WLAN/BT 2.4GHz simultaneous RX/RX

Optional configuration for MIMO:

- WLAN 2.4/5GHz + BT
- WLAN/BT 2.4GHz simultaneous RX/RX
- WLAN 2.4GHz MIMO

3.4 Bluetooth Functional Block

3.4.1 BT Digital Radio Processor (DRP)

The Device uses 8th-generation TI Bluetooth technology, with new features and improved radio performance.

3.4.2 BT Receiver

The receiver uses near-zero-IF architecture to convert the RF signal to baseband data. Received signal from the external antenna is input to an internal RF switch and a differential LNA (low-noise amplifier).

This signal is then passed to a mixer which down-converts the signal to an IF, followed by a filter and amplifier. The signal is then quantized by a sigma-delta ADC. The quantized signal is further processed to reduce the interference level.

The demodulator digitally down-converts the signal to zero IF and recovers the data stream by an adaptive decision mechanism. The demodulator includes EDR processing with state-of-the-art performance. It includes a maximum-likelihood sequence estimator (MLSE) for improved performance of basic-rate BR sensitivity, and adaptive equalization to enhance EDR modulation.

3.4.3 BT Transmitter

The transmitter is based on an all-digital sigma-delta PLL with a digitally controlled oscillator (DCO) as the RF frequency clock. The modulation is achieved by directly modulating the digital PLL. The power amplifier is also digitally controlled.

For EDR modulation, the transmitter uses a Polar-Modulation technique. In this mode, in addition to the frequency modulation that controls the direct-modulated ADPLL, an amplitude control modulates the PA, using the Digital-Transmitter block. This block receives the input bit-stream and converts these signals to phase-modulated control-words. The phase-modulated digital signal is then processed to provide frequency-modulation control to the ADPLL.

3.4.4 Class 1.5 Application

Device provides on-chip support for Class 2 and Class 1.5 applications. Class 1.5 is the normal operating mode after the initialization script has been sent to the Device.

It is called Class 1.5 as Device can transmit more than 4dBm on any BT modulation.

Refer to Bluetooth RF Performance specifications at end of document for more information.

3.4.5 Advanced Audio features

The Device includes Audio and Voice Processor (AVPR) targeted for off-loading the host CPU from coding voice/audio samples when running A2DP and WBS profiles.

3.4.5.1 Assisted Wideband (WB) speech

- Encode/Decode 16kHz PCM audio samples to/from 64kbps SBC frames
- Fully compliant with the BT SIG Wideband speech profile

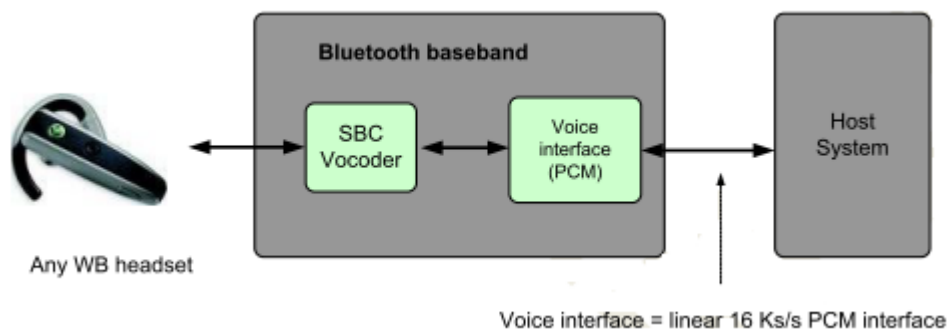

Figure 3-10 Device Wideband speech support

3.4.5.2 Assisted A2DP

- Encode 44.1/48kHz PCM audio samples to Low/Mid/High Quality A2DP stream
- Fully compliant with the BT SIG A2DP profile

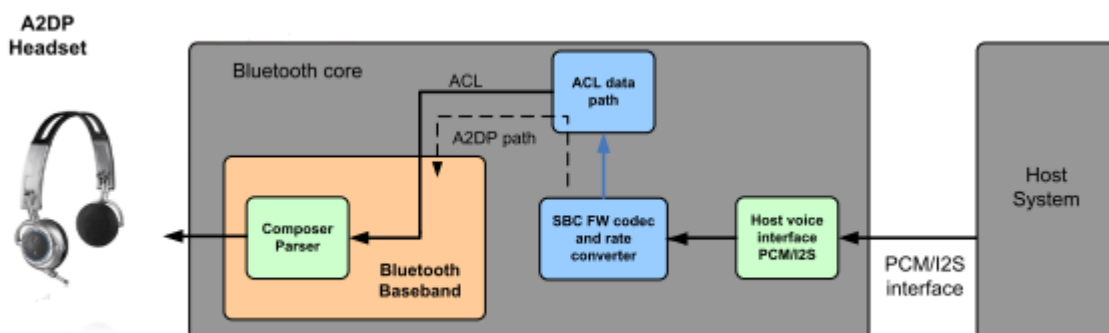

Figure 3-11 Device Assisted A2DP

3.5 Terminal Assignments

The view is from top side:

	A	B	C	D	E	F	G	H	J	K	L	M	N	P	
12	GND	BT_AUD_FSYNC_S B_DATA	GND	VIO	GND	GND	GND	GND	NC	NC	NC	NC	GND	GND	12
11	GND	BT_AUD_I N_SB_CLK K	GND	GND	GND	SDIO_D2_WL	SDIO_CLK_WL	GND	BT_AUD_OUT	GND	NC	GND	GND	NC	11
10	GND	BT_AUD_CLK	GND	FUNC2_B T	GND	SDIO_D3_WL	SDIO_D0_WL	GND	DC2DC_REQ_MODE_S SOC	CLK_REQ_OUT	GND	GND	GND	GND	10
9	GND	GND	GND	FUNC1_B T	GND	SDIO_CM D_WL	SDIO_D1_WL	GND	SLOW_CLK	NC	NC	GND	GND	NC	9
8	WLAN_BG 2	GND	NC	NC	GND	GND	GND	COEX_M WS_BT_W L_TX_O	COEX_M WS_FRAM E_SYNC	NC	NC	GND	GND	NC	8
7	GND	GND	NC	GND	GND	COEX_M WS_ACTI VE	RX_SW_F EM_WL	COEX_M WS_RX_P RI	NC	NC	GND	GND	GND	NC	7
6	NC	GND	PBIAS_TE STP_W	GND	GND	DC2DC_REQ_OUT_S SOC	WLAN_IR Q	UART_DE BUG	GPIO_2	NC	NC	GND	GND	NC	6
5	GND	GND	PDET_TE STM_W	GND	GND	GND	WLAN_EN _SOC	FEM_PA EN_WL	NC	GPIO_1	GND	GND	GND	GND	5
4	GND	GND	NC	GND	BT_EN_S OC	BT_HCL_R X	BT_HCL_T X	BT_HCL_R TS	BT_HCL_C TS	GPIO_3	GND	VBAT1	VBAT2	VBAT3	4
3	11abg_AN T_1	GND	GND	GND	GND	GND	GND	GND	GND	GND	GND	GND	GND	GND	3
2	GND	GND	GND	GND	GND	CLK_IN_P	CLK_IN_M	GND	GND	GND	GND	GND	GND	GND	2
1	GND	GND	GND	GND	GND	GND	GND	GND	PA_DC2D C_IN	PA_DC2D C_OUT	GND	GND	GND	GND	1

	DIGITAL
	RF
	Power
	GND
	CLOCK
	DIGITAL High Speed
	Not Used NC

Top view

Figure 3-12 Terminal Assignments

3.6 Terminal Functions

Pin names and pin numbers in bracket apply to WSP pin out.

Table 3-3 Terminal Functions

Module Pin Name (WSP Pin Name)	Module Pin No. (WSP ball no.)	I/O Type	Shut Down state	Default after POR	Buffer Type [mA]	Description
WLAN pins: I/O signals						
SDIO_CLK_WL (SDIO_CLK_WL)	G11 (E11)	IN	HiZ	HiZ		WLAN SDIO clock. Must be driven by the host.
SDIO_CMD_WL(SDIO_CMD_WL)	F9 (D8)	IN	HiZ	HiZ		WLAN SDIO command in. Host must pull up.
SDIO_D0_WL (SDIO_D0_WL)	G10 (E10)	I/O	HiZ	HiZ		WLAN SDIO data bit 0. Host must pull up.
SDIO_D1_WL (SDIO_D1_WL)	G9 (E9)	I/O	HiZ	HiZ		WLAN SDIO data bit 1. Host must pull up.
SDIO_D2_WL (SDIO_D2_WL)	F11 (D11)	I/O	HiZ	HiZ		WLAN SDIO data bit 2. Host must pull up.
SDIO_D3_WL (SDIO_D3_WL)	F10 (D10)	I/O	HiZ	PU		WLAN SDIO data bit 3. Changes state to PU at WL_EN or BT_EN assertion for card detect. Later disabled by the SW during init. Host must pull up.
WLAN_IRQ (IRQ_WL)	G6 (E3)	OUT	PD	Drive 0		SDIO available, interrupt out. Active high. To use WL_RS232_TX/RX lines, need to pull up with 10K resistor.
GPIO_1 (GPIO1)	K5 (H1)	I/O	PD	PD		Option: WL_RS232_TX (when IRQ_WL = 1 at power up)
GPIO_2 (GPIO2)	J6 (H2)	I/O	PD	PD		Option: WL_RS232_RX (when IRQ_WL = 1 at power up)
GPIO_3 (UART_DBG_WL)	K4 (G4)	OUT	PU	PU		WLAN logger Option: GPIO3
FEM_PA_EN_WL (GPIO13)	H5 (F2)					NC
RX_SW_FEM_WL (SW_CTRL_BG_IO1)	G7 (F3)					NC
PBIAS_TESTP_W (PBIAS_OUT_FEM_TESTP_WL)	C6 (C7)	ANA				NC
PDET_TESTM_W (PDET_IN_FEM_TESTM_WL)	C5 (C6)	ANA				NC
WLAN Pins: RF antenna						
11abg_ANT_1	A3	RF				WLAN ABG / BT RX and TX 50Ω input and output. No external matching required.
WLAN_BG2	A8	RF				Second 2.4GHz WLAN BG input and output for MIMO functionality. Requires external RF filter.
BT pins: I/O Signals						
BT_HCI_RX (HCI_RX_BT)	F4 (E7)	IN	PU	PU		HCI UART RX from host. Shared HCI I/F for BT. NC if not used.
BT_HCI_TX (HCI_TX_BT)	G4 (F7)	OUT	PU	PU		HCI UART TX to host. Shared HCI I/F. NC if not used.

Module Pin Name (WSP Pin Name)	Module Pin No. (WSP ball no.)	I/O Type	Shut Down state	Default after POR	Buffer Type [mA]	Description
BT_HCI_RTS (HCI_RTS_BT)	H4 (G6)	OUT	PU	PU		HCI UART RTS to host. Shared HCI I/F. NC if not used.
BT_HCI_CTS (HCI_CTS_BT)	J4 (F6)	IN	PU	PU		HCI UART CTS from host. Shared HCI I/F. NC if not used.
UART_DEBUG (UART_DEBUG_BT)	H6 (G2)	OUT	PU	PU		BT UART debug (logger). NC if not used.
FUNC1_BT (FUNC1_BT)	D9 (E8)	OUT	PD	PD		Optional: BT_HOST_WAKE_UP signal to wake-up the HOST from BT. NC if not used.
FUNC2_BT (FUNC2_BT)	D10 (B11)	IN	PD	PD		Optional: BT_WAKE_UP Bluetooth wakeup from HOST. NC if not used.
BT_AUD_CLK (AUD_CLK_BT)	B10 (G11)	OUT	PD	PD		BT PCM/I2S bus clock. NC if not used.
BT_AUD_FSYNC_SB_DATA (AUD_FSYNC_BT)	B12 (H11)	OUT	PD	PD		BT PCM/I2S bus frame sync. NC if not used.
BT_AUD_IN_SB_CLK (AUD_IN_BT)	B11 (G9)	IN	PD	PD		BT PCM/I2S bus data input. NC if not used.
BT_AUD_OUT (AUD_OUT_BT)	J11 (G10)	OUT	PD	PD		BT PCM/I2S bus data output. NC if not used.
JTAG pins						
JTAG_TCK	C8 (F11)	IN	PD	PD		JTAG_TCK NC if not used
JTAG_TMS	C7 (F8)	IN	PD	PD		JTAG_TMS NC if not used
JTAG_TDI	C4 (F9)	IN	PD	PD		JTAG_TDI NC if not used
JTAG_TDO	D8 (F10)	OUT	PD	PD		JTAG_TDO NC if not used
Clock pins						
CLK_IN_P	F2 (E4)	ANA				FREF/TCXO input for all functional blocks
CLK_IN_M	G2 (E5)	ANA				Connect to GND
SLOW_CLK (RTC_CLK)	J9 (H8)	ANA				Sleep clock 32.768 kHz
CLK_REQ_OUT	K10 (K11)	OUT	PD	PD		Request external fast clock NC if not used.
Enable pins						
BT_EN_SOC (BT_EN)	E4 (E2)	IN	PD	PD		High = enable
WLAN_EN_SOC (WLAN_EN)	G5 (E1)	IN	PD	PD		High = enable
Power management pins						
VBAT1	M4	POW				Battery voltage
VBAT2	N4	POW				Battery voltage
VBAT3	P4	POW				Battery voltage
VIO	D12	POW				1.8V I/O power supply
PA_DC2DC_IN	J1	POW				PA power supply input, with internal PA_DC2DC connect to pin PA_DC2DC_OUT K1.
PA_DC2DC_OUT	K1	POW				DC2DC output for PA supply, with internal PA_DC2DC connect to pin PA_DC2DC_IN J1.
DC2DC_REQ_OUT_SOC (NU)	F6 (D3)					NC
DC2DC_REQ_MODE_SOC (NU)	J10 (J10)					NC

Module Pin Name (WSP Pin Name)	Module Pin No. (WSP ball no.)	I/O Type	Shut Down state	Default after POR	Buffer Type [mA]	Description
Co-existence signals						
COEX_MWS_RX_PRI (COEX_MWS_UART_RX)	H7 (G5)		PU	PU		General purpose IO. NC if not used.
COEX_MWS_BT_WL_TX_O (COEX_MWS_UART_TX)	H8 (G7)		PU	PU		General purpose IO. NC if not used.
COEX_MWS_ACTIVE (COEX_MWS_PRE_TX)	F7 (G8)		PU	PU		General purpose IO. NC if not used.
COEX_MWS_FRAME_SYNC (COEX_MWS_FRAME_SYNC)	J8 (H7)		PU	PU		General purpose IO. NC if not used.
Not used pins						
NU	A6					NC
NU	J5					NC
NU	J7					NC
NU	J12					NC
NU	K6					NC
NU	K7					NC
NU	K8					NC
NU	K9					NC
NU	K12					NC
NU	L6					NC
NU	L8					NC
NU	L9					NC
NU	L11					NC
NU	L12					NC
NU	M12					NC
NU	P6					NC
NU	P7					NC
NU	P8					NC
NU	P9					NC
NU	P11					NC
Ground pins						
GND	A1	GND				
GND	A2	GND				
GND	A4	GND				
GND	A5	GND				
GND	A7	GND				
GND	A9	GND				
GND	A10	GND				
GND	A11	GND				
GND	A12	GND				
GND	B1	GND				
GND	B2	GND				
GND	B3	GND				
GND	B4	GND				
GND	B5	GND				

Module Pin Name (WSP Pin Name)	Module Pin No. (WSP ball no.)	I/O Type	Shut Down state	Default after POR	Buffer Type [mA]	Description
GND	B6	GND				
GND	B7	GND				
GND	B8	GND				
GND	B9	GND				
GND	C1	GND				
GND	C2	GND				
GND	C3	GND				
GND	C9	GND				
GND	C10	GND				
GND	C11	GND				
GND	C12	GND				
GND	D1	GND				
GND	D2	GND				
GND	D3	GND				
GND	D4	GND				
GND	D5	GND				
GND	D6	GND				
GND	D7	GND				
GND	D11	GND				
GND	E1	GND				
GND	E2	GND				
GND	E3	GND				
GND	E5	GND				
GND	E6	GND				
GND	E7	GND				
GND	E8	GND				
GND	E9	GND				
GND	E10	GND				
GND	E11	GND				
GND	E12	GND				
GND	F1	GND				
GND	F3	GND				
GND	F5	GND				
GND	F8	GND				
GND	F12	GND				
GND	G1	GND				
GND	G3	GND				
GND	G8	GND				
GND	G12	GND				

Module Pin Name (WSP Pin Name)	Module Pin No. (WSP ball no.)	I/O Type	Shut Down state	Default after POR	Buffer Type [mA]	Description
GND	H1	GND				
GND	H2	GND				
GND	H3	GND				
GND	H9	GND				
GND	H10	GND				
GND	H11	GND				
GND	H12	GND				
GND	J2	GND				
GND	J3	GND				
GND	K2	GND				
GND	K3	GND				
GND	K11	GND				
GND	L1	GND				
GND	L2	GND				
GND	L3	GND				
GND	L4	GND				
GND	L5	GND				
GND	L7	GND				
GND	L10	GND				
GND	M1	GND				
GND	M2	GND				
GND	M3	GND				
GND	M5	GND				
GND	M6	GND				
GND	M7	GND				
GND	M8	GND				
GND	M9	GND				
GND	M10	GND				
GND	M11	GND				
GND	N1	GND				
GND	N2	GND				
GND	N3	GND				
GND	N5	GND				
GND	N6	GND				
GND	N7	GND				
GND	N8	GND				
GND	N9	GND				
GND	N10	GND				
GND	N11	GND				

Module Pin Name (WSP Pin Name)	Module Pin No. (WSP ball no.)	I/O Type	Shut Down state	Default after POR	Buffer Type [mA]	Description
GND	N12	GND				
GND	P1	GND				
GND	P2	GND				
GND	P3	GND				
GND	P5	GND				
GND	P10	GND				
GND	P12	GND				

4 Design Goal Specifications

Section Disclaimer

This Specification is based upon the Texas Instruments WL183x Data Sheet version 1.4, and is subject to any subsequent changes in applicable Texas Instruments documentation and software.

Any parameter marked TBD indicates that this is yet to be determined by TDK design/testing. Any parameter marked TBC indicates that this is yet to be determined in an update of Texas Instruments documentation.

4.1 General Chip Requirements and Operation

All parameters are measured as follows unless stated otherwise: VIO=1.8V

4.1.1 Absolute Maximum Ratings ⁽¹⁾

			Value	Unit
VBAT ⁽²⁾			-0.5 to 5.5 ⁽⁴⁾	V
VIO			-0.5 to 2.1	V
Input voltage to Analog pins ⁽³⁾			-0.5 to 2.1	V
Input voltage to all other pins			-0.5 to (VDD_IO + 0.5V)	V
Operating ambient temperature range			-40 to +85 ⁽⁵⁾	°C
ESD Stress Voltage ⁽⁶⁾	Human Body Model ⁽⁷⁾	RF pins	>500	V
		Other	>1000	V
	Charged Device Model ⁽⁸⁾	RF pins	>300	V
		Other	>250	V

(1) Stresses beyond those listed under “absolute maximum ratings” may cause permanent damage to the device. These are stress ratings only and functional operation of the device at these or any other conditions beyond those indicated under “recommended operating conditions” is not implied. Exposure to absolute-maximum-rated conditions for extended periods may affect device reliability.

(2) The following signals are from the VBAT group: VBAT1, VBAT2, VBAT3

(3) Analog pins: WLAN_BG2, 11abg_ANT_1.

(4) 5.5V up to 10s cumulative in 7 years. 5V cumulative to 250s, 4.8V cumulative to 2.33 years – all includes charging dips and peaks.

(5) Operating free-air temperature range. The device can be reliably operated for 7 years at T_{ambient} of 85°C, assuming 25% active mode and 75% sleep mode (15,400 cumulative active power-on hours).

(6) Electrostatic discharge (ESD) to measure device sensitivity/immunity to damage caused by electrostatic discharges into the device.

(7) Level listed is the passing level per ANSI/ESDA/JEDEC JS-001. JEDEC document JEP155 states that 500V HBM allows safe manufacturing with a standard ESD control process, and manufacturing with less than 500V HBM is possible if necessary precautions are taken. Pins listed as 1000V may actually have higher performance.

(8) Level listed is the passing level per EIA-JEDEC JESD22-C101E. JEDEC document JEP157 states that 250 V CDM allows safe manufacturing with a standard ESD control process, and manufacturing with less than 250V CDM is possible if necessary precautions are taken. Pins listed as 250 V may actually have higher performance.

4.1.2 Recommended Operating Conditions

Rating	Condition	Sym	Min	Max	Unit
1.8V core supply voltage			1.7	1.95	V
Vbat	DC supply range for all modes		3.4	4.3	
IO high-level input voltage		VIH	0.65 x VDD_IO	VDD_IO	
IO low-level input voltage		VIL	0	0.35 x VDD_IO	
Enable inputs high-level input voltage		Vih_en	1.365	VDD_IO	
Enable inputs low-level input voltage		Vil_en	0	0.4	
High-level output voltage	@4 mA	VOH	VDD_IO – 0.45	VDD_IO	
	@ 1 mA		VDD_IO – 0.112	VDD_IO	
	@0.3 mA		VDD_IO- 0.033	VDD_IO	
Low-level output voltage	@4 mA	VOL	0	0.45	
	@ 1 mA		0	0.112	
	@0.09 mA		0	0.01	
Input transitions time Tr/Tf from 10% to 90% (Digital IO) ⁽¹⁾		Tr/Tf	1	10	ns
Output rise time from 10% to 90% (Digital pins) ⁽¹⁾	CL <25 pF	Tr		5.3	ns
Output fall time from 10% to 90% (Digital pins) ⁽¹⁾	CL <25 pF	Tf		4.9	
Ambient operating temperature			-40	+85	°C

(1) Applies to all Digital lines except SDIO, SPI, UART, I2C, PCM and slow clock lines

4.1.3 External Digital Slow Clock Requirements (-40°C to +85°C)

The supported digital slow clock is 32.768 kHz digital (square wave). All core functions share a single input.

Characteristics	Condition	Sym	Min	Typ	Max	Unit
Input slow clock frequency				32768		Hz
Input slow clock accuracy (initial + temp + aging)	WLAN, BT				±250	ppm
Input transition time Tr/Tf -IO% to 90%		Tr/Tf			100	ns
Frequency input duty cycle			15	50	85	%
Input voltage limits	Square wave, DC-coupled	Vih	0.65xVDD_I O		VDD_IO	Vpeak
		Vil	0		0.35xVDD_I O	
Input impedance			1			MΩ
Input capacitance					5	pF

4.1.4 External fast clock Crystal Requirements and operation (-40°C to +85°C)

Characteristics	Condition	Min	Typ	Max	Unit
Supported frequencies		26, 38.4			MHz
Frequency accuracy	Initial + temp + aging			±20	ppm
Load capacitance, $C_L^{(1)}$		5		13	pF
Equivalent Series Resistance, ESR				60	ohms
Drive level			100		uW

1) Load capacitance, $C_L = [C1.C2] / [C1 + C2] + CP$, where C1, C2 are the capacitors connected on CLK_IN_P & CLK_IN_M respectively and CP is the parasitic capacitance (typically 1-2pF).

For example, for C1 = C2 = 12pF and CP = 2pF, then CL = 8pF.

4.1.5 External TCXO CLK Requirements (-40°C to +85°C)

Parameter	Conditions	Min	Typ	Max	Unit
Supported frequency		26, 38.4			MHz
Frequency accuracy	Total short and long term			±20	ppm
Input voltage limits (TCXO_P)	Sine wave/ ac-coupled	2.4GHz WLAN	0.2	1.4	Vp-p
		5GHz WLAN	0.8	1.4	
Input impedance, 26 MHz	RP	Input resistance			kΩ
	CP	Input capacitance			pF
Input impedance, 38.4 MHz	RP	Input resistance			kΩ
	CP	Input capacitance			pF
Power-up time ⁽¹⁾				5	ms
Phase noise 2.4GHz for 38.4MHz 20MHz SISO ⁽²⁾	Measured at 1 KHz offset			-120	dBc/Hz
	Measured at 10 KHz offset			-130	dBc/Hz
	Measured at 100 KHz offset			-135	dBc/Hz
Phase noise 2.4GHz for 38.4MHz 40MHz SISO ⁽²⁾	Measured at 1 KHz offset			-125	dBc/Hz
	Measured at 10 KHz offset			-132	dBc/Hz
	Measured at 100KHz offset			-136.5	dBc/Hz
Phase noise 2.4GHz for 38.4MHz 20MHz MIMO ⁽²⁾	Measured at 1 KHz offset			-125	dBc/Hz
	Measured at 10 KHz offset			-139	dBc/Hz
	Measured at 100KHz offset			-144	dBc/Hz
Phase noise 5GHz for 38.4MHz, 20/40MHz SISO ⁽²⁾	Measured at 1 KHz offset			-125	dBc/Hz
	Measured at 10 KHz offset			-142	dBc/Hz
	Measured at 100KHz offset			-145	dBc/Hz

(1) Power-up time is calculated from the time CLK_REQ_OUT asserted till the time the TCXO_CLK amplitude is within voltage limit specified above and TCXO_CLK frequency is within ±0.1 ppm of final steady state frequency.

(2) The phase noise numbers listed here must be met at 38.4 MHz. For other frequencies the phase noise requirement is corrected by adding $20 \times \log_{10}(f_{TCXO} / 38.4e6)$ dB. Specifically, for 26 MHz TCXO, the correction factor would be -3.4 dB.

* The slope of the clock at zero-crossings should not be less than that of a 200 mVp-p sine-wave (800 mVp-p for 11a band). i.e. 26MHz clock: 16V/μs (for 11bg band) 38.4MHz clock: 24V/μs (for 11bg band)

4.2 WLAN RF Performance

All specifications in this draft data sheet are design goal level and subject to change. All specifications have been measured using TDK CB (Carrier Board) and are given at the module pins (Carrier Board insertion loss is de-embedded). All measurements have been performed over VBAT voltage range from 3.4V to 4.3V and over temperature range from -40°C to +85°C.

* MIMO function is confirmed by only WL183x.

* 11n 40MHz bandwidth function is available. However the RF performance is guaranteed by only WL183x.

4.2.1 WLAN 2.4 GHz Radio Characteristics

4.2.1.1 WLAN 2.4 GHz Receiver RF Characteristics

Characteristics	Condition	Min	Typ	Max	Unit
Operation frequency range		2400		2480	MHz
Sensitivity (ANT1) 20MHz bandwidth. At < 10% PER limit	1 Mbps DSSS			-91	dBm
	54 Mbps OFDM			-70	
	MCS7			-65	
Max Input Level At < 10% PER limit	OFDM (11g/n)	-19			dBm
	CCK	-4			
Adjacent Channel Rejection at sensitivity level +3 for OFDM and +6 for CCK	2Mbps	42.7			dB
	11 Mbps	37.9			
	54 Mbps	2			
LO leakage			-80		dBm

4.2.1.2 WLAN 2.4 GHz Receiver Blocking Characteristics Per Band

The R078 (WL1837) / D7020 is designed to coexist with co-located cellular transmitters. Table below lists typical cellular interference sources and the corresponding maximum power from the cellular interference source that can be present at the input terminal of R078 (WL1837) / D7020, such that WLAN receiver sensitivity is not degraded by more than 1 dB. (Further improvement is achieved by antenna isolation)

Characteristics	Condition	Min	Typ	Max	Unit
Blocking performance at other bands	776 to 794 MHz (CDMA)	+10			dBm
	824 to 849 MHz (GMSK)	+10			
	824 to 849 MHz (EDGE)	+10			
	824 to 849 MHz (CDMA)	+10			
	880 to 915 MHz (GMSK)	+21			
	880 to 915 MHz (EDGE)	+21			
	1710 to 1785 MHz (GMSK)	+3			
	1710 to 1785 MHz (EDGE)	+3			
	1850 to 1910 MHz (GMSK)	-3			
	1850 to 1910 MHz (EDGE)	-3			
	1850 to 1910 MHz (CDMA)	-10			
	1850 to 1910 MHz (WCDMA)	-10			
	1920 to 1980 MHz (WCDMA)	-10			

4.2.1.3 WLAN 2.4 GHz Transmitter power

RF transmission (Tx) tests are done in continuous transmission.

Characteristics	Condition	11abg_ANT_1 pin			WLAN_BG2 pin			Unit
		Min	Typ	Max	Min	Typ	Max	
Maximum output power -Notice that WLAN_BG2 path requires external RF filter.	1 Mbps	+12	+15					dBm
	11Mbps	+12	+15					
	6 Mbps at EVM: -10 dB,	+10	+13		+16	+19		
	54 Mbps at EVM: -25 dB	+9	+12		+13.5	+15		
	MCS0 (Greenfield) at EVM: -10 dB	+9	+13		+15.6	+19		
	MCS7 (Greenfield) at EVM: -28 dB	+8	+11		+12.1	+14		
Output power accuracy			±1.5		±1.5		dB	
Transmit power control resolution			0.125		0.125		dB	

4.2.1.4 WLAN 2.4 GHz Transmitter out-of-band emissions

Table below shows 2.4GHz WLAN transmitter out-of-band emissions for each band listed in the Condition column. The wideband noise at 2.4GHz WLAN antenna port is also listed.

Characteristics	Condition	Min	Typ	Max	Unit
Cellular bands out-of-band broadband emissions(1)	746 to 764 MHz (CDMA1)			-145	dBm/Hz
	869 to 894 MHz (GSM850)			-145	
	925 to 960 MHz (EGSM900)			-138	
	1570 to 1580 MHz (GPS)			-142	
	1596 to 1609 MHz (GLONASS)			-130	
	1805 to 1880 MHz (DCS1800)			-140	
	1930 to 1990 MHz (PCS1900)			-120	
	2110 to 2170 MHz			-129	
Cellular bands out-of-band spurious emissions	746 to 764 MHz (CDMA)			-44.2 ⁽⁴⁾	dBm
	869 to 894 MHz (CDMA, GSM850)			-44.2 ⁽⁴⁾	
	925 to 960 MHz (EGSM900)			-44.2 ⁽⁴⁾	
	1570 to 1580 MHz (GPS)			-44.2 ⁽⁴⁾	
	1805 to 1880 MHz (DCS1800)			-44.2 ⁽⁴⁾	
	1930 to 1990 MHz (PCS1900, CDMA)			-44.2 ⁽⁴⁾	
	2110 to 2170 MHz			-44.2 ⁽⁴⁾	
Spurious emission during operation at 1MHz RBW	30MHz – 1GHz			-55 ⁽²⁾	dBm
	2 nd harmonic			-33 ⁽³⁾	
	3 rd harmonic			-33 ⁽³⁾	
	4 th harmonic			-33 ⁽³⁾	
	5 th harmonic			-33 ⁽³⁾	

(1) Figures are for max transmission power for all available modulations. The setup noise floor is -167dBm/Hz.

(2) Based on TI IC performance

(3) ETSI limit plus 3dB margin

(4) FCC conductive limit plus 3dB margin

4.2.1.5 2.4GHz WLAN Current Consumption

Active Current				
Spec item ⁽¹⁾	MIN	TYP	MAX	Units
Tx 11CCK @15dBm		345	380	mA
Tx 54OFDM @12dBm		290	320	mA
Rx		65	75	mA

(1) All measured at ANT1 and the 3.6V VBAT rail of the solution. TCXO current included.

4.2.2 WLAN 5 GHz Radio Characteristics

4.2.2.1 WLAN 5 GHz Receiver RF Characteristics

Characteristics	Condition	Min	Typ	Max	Unit
Operation frequency range		4910		5835	MHz
Sensitivity ⁽¹⁾	54 Mbps OFDM			-70	dBm
Notes: -20MHz bandwidth. -At < 10% PER limit	MCS7			-65	
Max Input Level	802.11a/n	-27			dBm
Adjacent channel rejection	54 Mbps	2			
LO leakage			-53		dBm

(1) The sensitivity is guaranteed at only 36ch (5180MHz).

4.2.2.2 WLAN 5 GHz Receiver Blocking Characteristics Per Band

The R078 (WL1837) / D7020 is designed to coexist with co-located cellular transmitters. Table below lists typical cellular interference sources and the corresponding maximum power from the cellular interference source that can be present at the input terminal of R078 (WL1837) / D7020, such that WLAN receiver sensitivity is not degraded by more than 1 dB. (Further improvement is achieved by antenna isolation)

Characteristics	Condition	Min	Typ	Max	Unit
Blocking performance at other bands	776 to 794 MHz (CDMA)	-10			dBm
	824 to 849 MHz (GMSK)	-10			
	824 to 849 MHz (EDGE)	-10			
	824 to 849 MHz (CDMA)	-10			
	880 to 915 MHz (GMSK)	-10			
	880 to 915 MHz (EDGE)	-10			
	1710 to 1785 MHz (GMSK)	-10			
	1710 to 1785 MHz (EDGE)	-18			
	1850 to 1910 MHz (GMSK)	-39			
	1850 to 1910 MHz (EDGE)	-39			
	1850 to 1910 MHz (CDMA)	-39			
	1850 to 1910 MHz (WCDMA)	-39			
	1920 to 1980 MHz (WCDMA)	-23			

4.2.2.3 WLAN 5 GHz Transmitter power

RF transmission (Tx) tests are done in continuous transmission.

Characteristics	Condition	Min	Typ	Max	Unit
	6 Mbps at EVM: -10 dB,	+10	+12		dBm
	54 Mbps at EVM: -25 dB	+6	+9		
	MCS0 (Greenfield) at EVM: -10 dB	+8	+11		
	MCS7 (Greenfield) at EVM: -28 dB	+7	+14		
Output power accuracy		-1.5		+1.5	dB
Transmit power control resolution			0.125		dB

4.2.2.4 WLAN 5 GHz Transmitter out-of-band emissions

Table below shows 5GHz WLAN transmitter out-of-band emissions for each band listed in the Condition column. The wideband noise at 5GHz WLAN antenna port is also listed.

Characteristics	Condition	Min	Typ	Max	Unit
Cellular bands out-of-band broadband emissions	746 to 764 MHz (CDMA2000)			-143	dBm/Hz
	869 to 894 MHz (GSM850)			-143	
	925 to 960 MHz (EGSM900)			-143	
	1570 to 1580 MHz (GPS)			-145	
	1570 to 1580 MHz (GLONASS)			-145	
	1805 to 1880 MHz (DCS1800)			-110	
	1930 to 1990 MHz (PCS1900)			-105	
	2110 to 2170 MHz (WCDMA FDD)			-142	
Cellular bands out-of-band spurious emissions	746 to 764 MHz (CDMA2000)			-44.2 ⁽⁴⁾	dBm
	869 to 894 MHz (GSM850)			-44.2 ⁽⁴⁾	
	925 to 960 MHz (EGSM900)			-44.2 ⁽⁴⁾	
	1570 to 1580 MHz (GPS)			-44.2 ⁽⁴⁾	
	1570 to 1580 MHz (GLONASS)			-44.2 ⁽⁴⁾	
	1805 to 1880 MHz (DCS1800)			-44.2 ⁽⁴⁾	
	1930 to 1990 MHz (PCS1900, CDMA)			-44.2 ⁽⁴⁾	
	2110 to 2170 MHz (WCDMA FDD)			-44.2 ⁽⁴⁾	
2 nd harmonic	11an			-33 ⁽³⁾	dBm

(1) Figures are for max transmission power for all available modulations. The setup noise floor is -167dBm/Hz.

(2) Based on TI IC performance

(3) ETSI Limit plus 3dB margin

(4) FCC conductive Limit plus 3dB margin

4.2.2.5 5GHz WLAN Current Consumption

Active Current				
Spec item ⁽¹⁾	MIN	TYP	MAX	Units
Tx 6 OFDM @ 12dBm		420	460	mA
Tx 54OFDM @ 9dBm		375	415	mA
Rx		75	85	mA

(1) All measured at the 3.6V VBAT rail of the solution. TCXO current included.

4.3 Bluetooth RF Performance

All specifications in this draft data sheet are design goal level and subject to change. All specifications have been measured using TDK CB (Carrier Board) and are given at the module pins (Carrier Board insertion loss is de-embedded). All measurements have been performed over VBAT voltage range from 3.4V to 4.3V and over temperature range from -40°C to +85°C.

4.3.1 Bluetooth BR, EDR Receiver Characteristics—In-Band Signals

Characteristics	Condition	Min	Typ	Max	Bluetooth Spec	Unit	
Operation frequency range		2402		2480		MHz	
Channel spacing			1			MHz	
Input impedance			50			Ω	
Sensitivity ⁽¹⁾ Dirty TX on	BR, BER = 0.1%	-86	-90		-70	dBm	
	EDR2, BER = 0.01%	-85	-89		-70		
	EDR3, BER = 0.01%	-78	-82		-70		
EDR BER floor at sensitivity + 10 dB, dirty TX off (for 1,600,00 bits)	EDR2, BER = 0.1%	1e-6			1e-5		
	EDR3, BER = 0.1%	1e-6			1e-5		
Maximum useable input power	BR, BER = 0.1%	-5			-20	dBm	
	EDR2, BER = 0.1%	-10			-20		
	EDR3, BER = 0.1%	-10			-20		
Intermodulation characteristics	Level of interferers For n = 3, 4, and 5	-36	-30		-39	dBm	
C/I performance Note: Numbers show wanted-signal to interfering-signal ratio. Smaller numbers indicate better C/I performance. Image = -1 MHz	BR, co-channel		8	10	11	dB	
	EDR, co-channel	EDR2		9.5	12		13
		EDR3		16.5	20		21
	BR, adjacent ± 1 MHz	EDR2		-10	-3		0
		EDR3		-10	-3		0
				-5	2		5
	BR, adjacent +2 MHz	EDR2		-38	-33		-30
		EDR3		-38	-33		-30
				-38	-28		-25
	BR, adjacent -2 MHz	EDR2		-28	-22		-20
		EDR3		-28	-20		-20
				-22	-13		-13
	BR, adjacent ± 3 MHz	EDR2		-45	-42		-40
EDR3			-45	-42	-40		
EDR, adjacent ± 3 MHz	EDR2		-44	-36	-33		
	EDR3		-44	-36	-33		
RF return loss				-10		dB	

(1) Sensitivity degradation up to -3 dBm may occur due to fast clock harmonics with dirty Tx on.

4.3.2 Bluetooth Receiver Characteristics—General Blocking

Characteristics	Condition	Min	Typ	Bluetooth Spec	Unit
Blocking performance over full range, according to Bluetooth specification ⁽¹⁾	30 to 2000 MHz	-6		-10	dBm
	2000 to 2399 MHz	-6		-27	
	2484 to 3000 MHz	-6		-27	
	3 to 12.75 GHz	-6		-10	

(1) Exceptions taken out of the total 24 allowed in the Bluetooth spec.

4.3.3 Bluetooth Receiver Characteristics—GFSK, EDR2, EDR3 Blocking Per Band

Characteristics	Condition	Min	Typ	Unit
Blocking performance for various cellular bands. Hopping on. Wanted signal: -3 dB from sensitivity, with modulated continuous blocking signal. BER = 0.1% for BT BR, BER = 0.01% for BT EDR, PER = 1%	776 to 794 MHz (CDMA) ⁽¹⁾	+13		dBm
	824 to 849 MHz (GMSK) ⁽¹⁾	+22		
	824 to 849 MHz (EDGE) ⁽¹⁾	+14		
	824 to 849 MHz (CDMA, QPSK) ⁽¹⁾	+13		
	880 to 915 MHz (GMSK)	+11		
	880 to 915 MHz (EDGE)	+10		
	1710 to 1875 MHz (GMSK)	+17		
	1710 to 1875 MHz (EDGE)	+3		
	1850 to 1910 MHz (GMSK)	-3		
	1850 to 1910 MHz (EDGE)	-5		
	1850 to 1910 MHz (CDMA, QPSK)	-5		
	1850 to 1910 MHz (WCDMA, QPSK)	-1		
	1920 to 1980 MHz (WCDMA, QPSK)	-2		

(1) Expect for frequencies where (3 x F_BLOCKER falls within the BT band (2400-2483.5 MHz).

4.3.4 Bluetooth Transmitter, BR, Class 1.5

Characteristics	Min	Typ	Max	Bluetooth Spec	Unit
RF output power	9	11			dBm
Gain control range		30			
Power control step	2	5	8	2 to 8	dBm
Adjacent channel power M-N = 2		-43	-35	< -20	
Adjacent channel power M-N > 2		-48	-40	< -40	

4.3.5 Bluetooth Transmitter, EDR, Class 1.5

Characteristics	Min	Typ	Max	Bluetooth Spec	Units
EDR relative power	-2		1	-4 to +1	dB
Gain control range		30			
Power control step	2	5	8	2 to 8	
Adjacent channel power M-N = 1		-36	-30	< -26	dBm
Adjacent channel power M-N = 2		-30	-23	< -20	
Adjacent channel power M-N > 2		-42	-40	< -40	

4.3.6 Bluetooth Modulation, BR—Class 1.5

Characteristics	Condition	Sym	Min	Typ	Max	Bluetooth Spec	Unit
-20 dB BW				925	995	1000	kHz
Average deviation detector bandwidth – 10 MHz	Mod Data = 4-1, 4-0 1111000011110000...	dF1 avg	145	160	170	140 to 175	kHz
Instantaneous deviation	Mod data = 10101... 1010101...	dF2 max	120	130		> 115	kHz
dF2/dF1			85	88		> 80	%
Carrier frequency drift	DH1		-25		25	< ±25	kHz
	DH3 and DH5		-35		35	< ±40	
Drift rate	$f_{k+5} - f_k$, $k = 0 \dots$				15	< 20	kHz/ 50μs
Initial carrier frequency tolerance	F0 –fTX		-25		25	<± 75	kHz

4.3.7 Bluetooth Modulation, EDR, Class 1.5

Characteristics	Condition	Min	Typ	Max	Bluetooth spec	Unit
Carrier frequency stability		-5		5	≤10	kHz
Initial carrier frequency tolerance		-25		25	± 75	kHz
RMS DEVM ⁽¹⁾	EDR2		4	15	20	%
	EDR3		4	10	13	%
99% DEVM ⁽¹⁾	EDR2			30	30	%
	EDR3			20	20	%
Peak DEVM ⁽¹⁾	EDR2		9	25	35	%
	EDR3		9	18	25	%

4.3.8 Bluetooth Transceiver, Out-of-Band Emissions

Characteristics	Condition	Typ	Max	Unit
TX out-of-band emissions	746 to 764 MHz (CDMA)		-143	dBm/Hz
	869 to 894 MHz (CDMA1, GSM)		-141	
	925 to 960 MHz (E-GSM)		-140	
	1570 to 1580 MHz (GPS)		-137	
	1598 to 1607 MHz (GLONASS)		-137	
	1805 to 1880 MHz (DCS, WCDMA)		-133	
	1930 to 1990 MHz (PCS)		-131	
	2110 to 2170 MHz (WCDMA)		-121	

4.3.9 Bluetooth Transceiver, Spurious Emissions

Characteristics	Condition	Typ	Max	Unit
out-of-band spurious emissions	76 to 108 MHz (FM)		-44.2	dBm
	746 to 764 MHz (CDMA)		-44.2	
	869 to 894 MHz (CDMA1, GSM)		-44.2	
	925 to 960 MHz (E-GSM)		-44.2	
	1570 to 1580 MHz (GPS)		-44.2	
	1805 to 1880 MHz (GSM)		-44.2	
	1930 to 1990 MHz (GSM, CDMA1, WCDMA)		-44.2	
	2110 to 2170 MHz (WCDMA)		-44.2	

4.4 BLE RF performance

All specifications in this draft data sheet are design goal level and subject to change. All specifications have been measured using TDK CB (Carrier Board) and are given at the module pins (Carrier Board insertion loss is de-embedded). All measurements have been performed over VBAT voltage range from 3.4V to 4.3V and over temperature range from -40°C to +85°C.

* BLE function is available. However the RF performance is guaranteed by only WL183x.

4.4.1 BLE Receiver Characteristics—In-Band Signals

Characteristics	Condition ⁽²⁾	Min	Typ	Max	BLE Spec	Unit
Operation frequency range		2402		2480		MHz
Channel spacing			2			MHz
Input impedance			50			Ω
Sensitivity ⁽¹⁾ Dirty TX on	dirty Tx on	-88	-91		≤ -70	dBm
Maximum useable input power		-5			≥ -10	dBm
Intermodulation characteristics	Level of interferers For n = 3, 4, and 5	-36	-30		≥ -50	dBm
C/I performance	BLE, co-channel		8	12	≤ 21	dB
Note: Numbers show wanted-signal to interfering-signal ratio. Smaller numbers indicate better C/I performance. Image = -1 MHz	BLE, adjacent ±1 MHz		-5	0	≥ 15	
	BLE, adjacent +2 MHz		-45	-38	≤ -17	
	BLE, adjacent -2 MHz		-22	-15	≤ -15	
	BLE, adjacent ≥ ± 3 MHz		-47	-40	≤ -27	

(1) Sensitivity degradation up to -3 dBm may occur due to fast clock harmonics with dirty Tx on.

(2) BER of 0.1% corresponds to PER of 30.8% for a minimum of 1500 transmitted packets, according to BLE test spec.

4.4.2 BLE Receiver Characteristics—General Blocking

Characteristics	Condition	Min	BLE spec	Unit
Blocking performance over full range, according to BLE specification ⁽¹⁾	30 to 2000 MHz	-15	-30	dBm
	2000 to 2399 MHz	-15	-35	
	2484 to 3000 MHz	-15	-35	
	3 to 12.75 GHz	-15	-30	

(1) Exceptions taken out of the total 10 allowed for fbf_1, according to the BT LE Spec.

4.4.3 BLE Receiver Characteristics—Blocking Per Band

Same as BT BR with following conditions:

- Hopping off.
- Desired signal: -3dB from sensitivity, with modulated continuous blocking signal. PER = 30.8%

4.4.4 BLE Transmitter

Characteristics	Min	Typ	Max	BLE Spec	Unit
RF output power	6	8		<10	dBm
Adjacent channel power $ M-N = 2$		-51	-43	< -20	dBm
Adjacent channel power $ M-N > 2$		-54	-46	< -30	

(1) BLE spec = 10dBm max can be achieved using normal system losses due to filters etc, or by reducing value through VS command.

4.4.5 BLE Modulation

Characteristics	Condition ⁽¹⁾	Min	Typ	Max	BLE Spec	Unit
BLE modulation characteristics	$\Delta F1$ avg Mod Data = 4-1, 4-0; 1111000011110000...	240	250	260	225 to 275	kHz
	$\Delta F2$ max \geq limit for at least 99.9% of all $\Delta f2$ max Mod data = 10101...	195	215		> 185	kHz
	$\Delta F2$ avg / $\Delta F1$ avg	85	90		> 80	%
BLE carrier frequency drift	$f_0 - f_n$, $n = 2,3 \dots K$	-25		25	< \pm 50	kHz
BLE drift rate	$ f_1 - f_0 $ and $ f_n - f_{n-5} $, $n = 6,7 \dots K$			15	< 20	kHz/50 μ s
BLE initial carrier frequency tolerance	$f_n - f_{tx}$	-25		25	< \pm 150	kHz

(1) Performance figures at maximum power.

4.4.6 BLE Transceiver, Out-Of-Band and Spurious Emissions

Same as BT basic rate.

4.5 Interface Timing Characteristics

4.5.1 UART timing

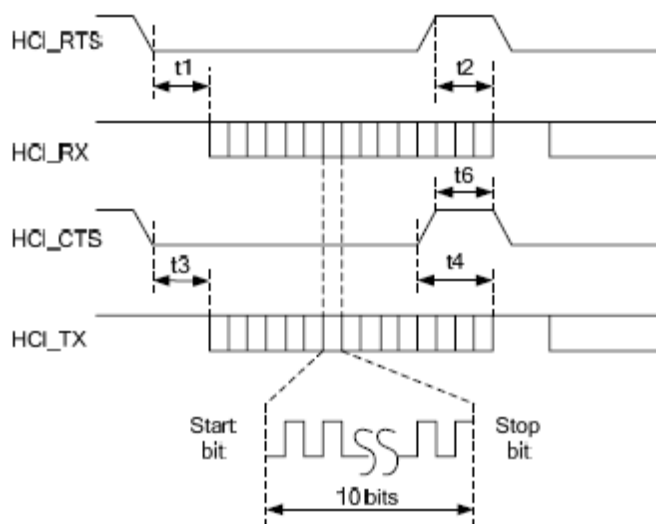
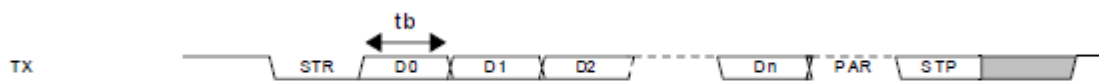

Figure 4-1 UART timing diagram

Table 4-1 UART timing

Parameter	Condition	Symbol	Min	Typ	Max	Unit
Baud rate			37.5		4364	Kbps
Baud rate accuracy per byte	Receive/Transmit		-2.5		+1.5	%
Baud rate accuracy per bit	Receive/Transmit		-12.5		+12.5	%
CTS low to TX_DATA on		t3	0	2		μs
CTS high to TX_DATA off	Hardware flow control	t4			1	Byte
CTS High Pulse Width		t6	1			Bit
RTS low to RX_DATA on		t1	0	2		μs
RTS high to RX_DATA off	Interrupt set to ¼ FIFO	t2			16	Bytes



- STR - Start bit
- D0..Dn - Data bits (LSB first)
- PAR - Parity bit (if used)
- STP - Stop bit

4.5.2 SDIO timing specifications

4.5.2.1 SDIO Switching Characteristics - Default rate input and output

Specification is over recommended operating conditions. Parameters are for default clock frequency.

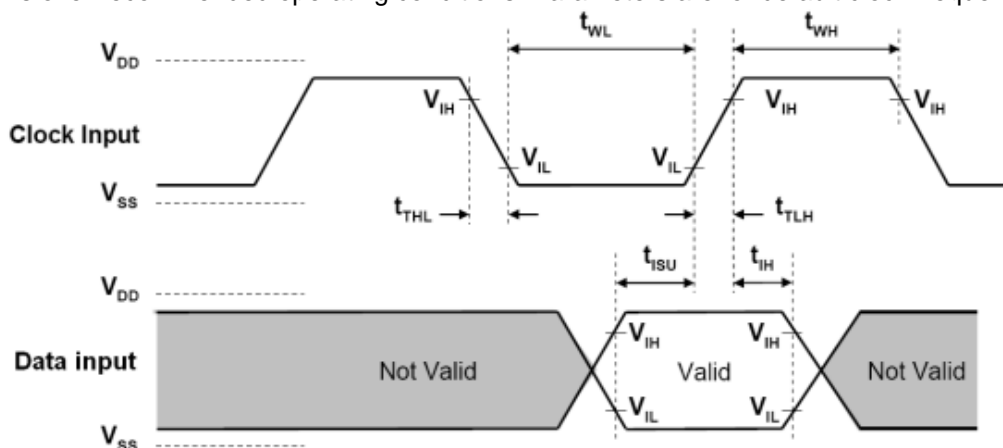

Figure 4-2 SDIO default input timing

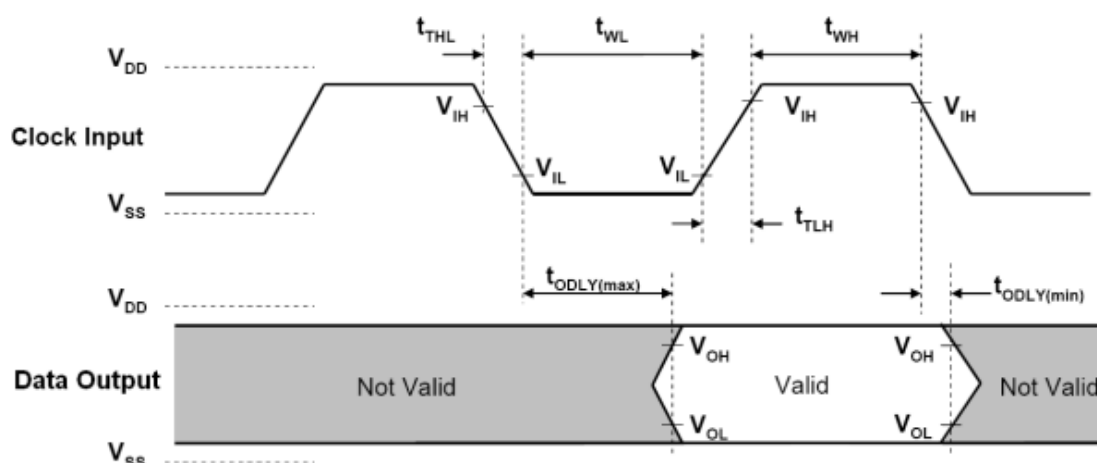

Figure 4-3 SDIO default output timing

Table 4-2 SDIO Switching Characteristics – Deault Rate

Parameter		Min	Max	Unit
f_{clock}	Clock frequency, CLK	0	26	MHz
DC	Low/high duty cycle	40	60	%
t_{TLH}	Rise time, CLK		10	ns
t_{THL}	Fall time, CLK		10	ns
t_{ISU}	Setup time, input valid before CLK \uparrow	3		ns
t_{IH}	Hold time, input valid after CLK \uparrow	2		ns
t_{ODLY}	Delay time, CLK \downarrow to output valid	2.5	14.8	ns
Cl	Capacitive load on outputs		15	pF

Note: Option to change data out clock edge from falling edge (default) to rising edge, by setting configuration bit.

4.5.2.2 SDIO Switching Characteristics - High Rate

Specification is over recommended operating conditions. Parameters are for maximum clock frequency.

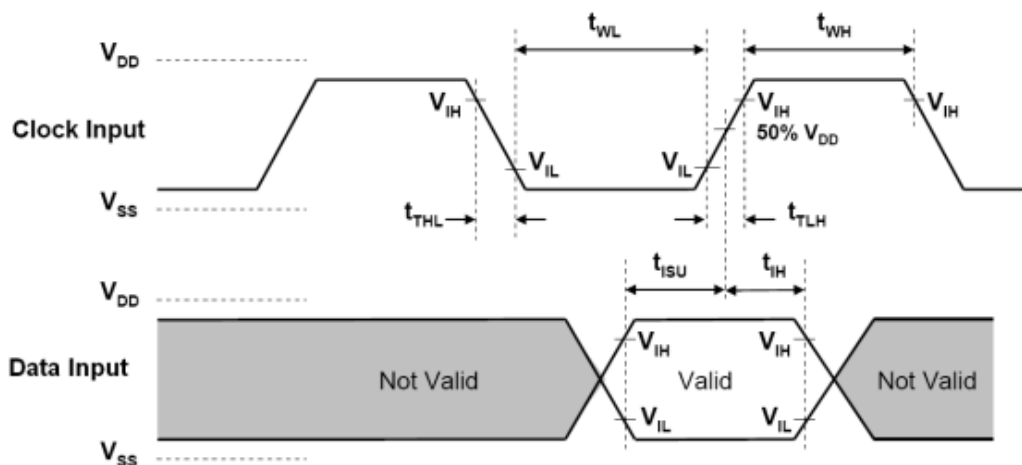

Figure 4-4 SDIO HS input timing

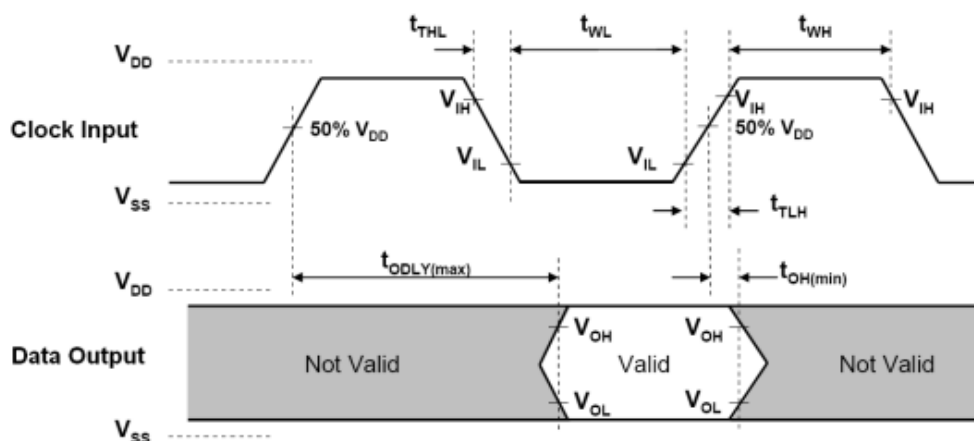
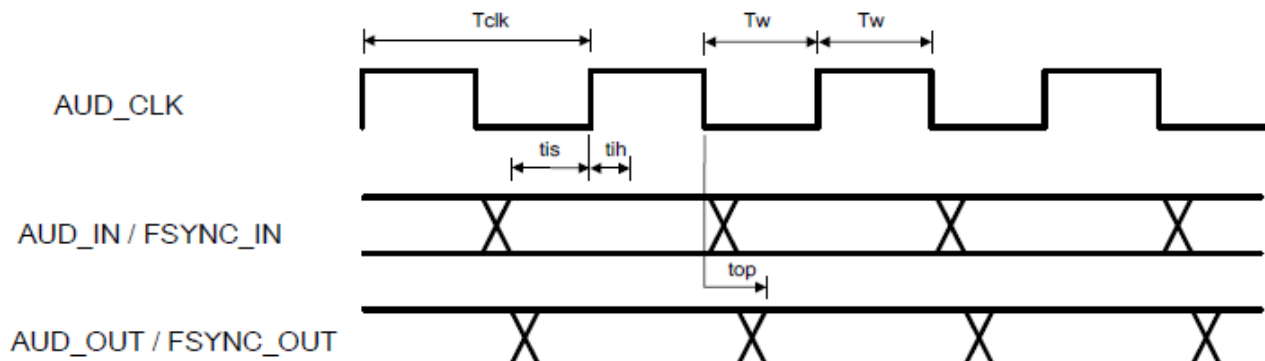

Figure 4-5 SDIO HS output timing

Table 4-3 SDIO Switching Characteristics – High Rate

Parameter		Min	Max	Unit
f_{clock}	Clock frequency, CLK	0	50	MHz
DC	Low/high duty cycle	40%	60%	
t_{TLH}	Rise time, CLK		3	ns
t_{THL}	Fall time, CLK		3	ns
t_{ISU}	Setup time, input valid before CLK \uparrow	3		ns
t_{IH}	Hold time, input valid after CLK \uparrow	2		ns
t_{ODLY}	Delay time, CLK \downarrow to output valid	2.5	14	ns
CI	Capacitive load on outputs		10	pF

4.5.3 BT Codec/PCM (audio) timing specifications

Figure 4-6 PCM Interface Timing
Table 4-5 PCM Master

Symbol	Parameter	Min	Max	Unit
t _{clk}	Cycle time	166.67 (6.144 MHz)	15625 (64 kHz)	ns
t _w	High or low pulse width	35% of Tclk min		
t _{is}	AUD_IN setup time	10.6		
t _{ih}	AUD_IN hold time	0		
t _{op}	AUD_OUT propagation time	0	15	
t _{op}	AUD_FSYNC_OUT propagation time	0	15	
CI	Capacitive loading on outputs		40	pF

Table 4-6 PCM Slave

Symbol	Parameter	Min	Max	Unit
t _{clk}	Cycle time	81 (12.288Hz)		ns
t _w	High or low pulse width	35% of Tclk min		
t _{is}	AUD_IN setup time	5		
t _{ih}	AUD_IN hold time	0		
t _{is}	AUD_FSYNC setup time	5		
t _{ih}	AUD_FSYNC hold time	0		
t _{op}	AUD_OUT propagation time	0	19	
CI	Capacitive loading on outputs		40	pF

4.6 Package Mechanical Drawing

Land Grid Array (LGA) Module

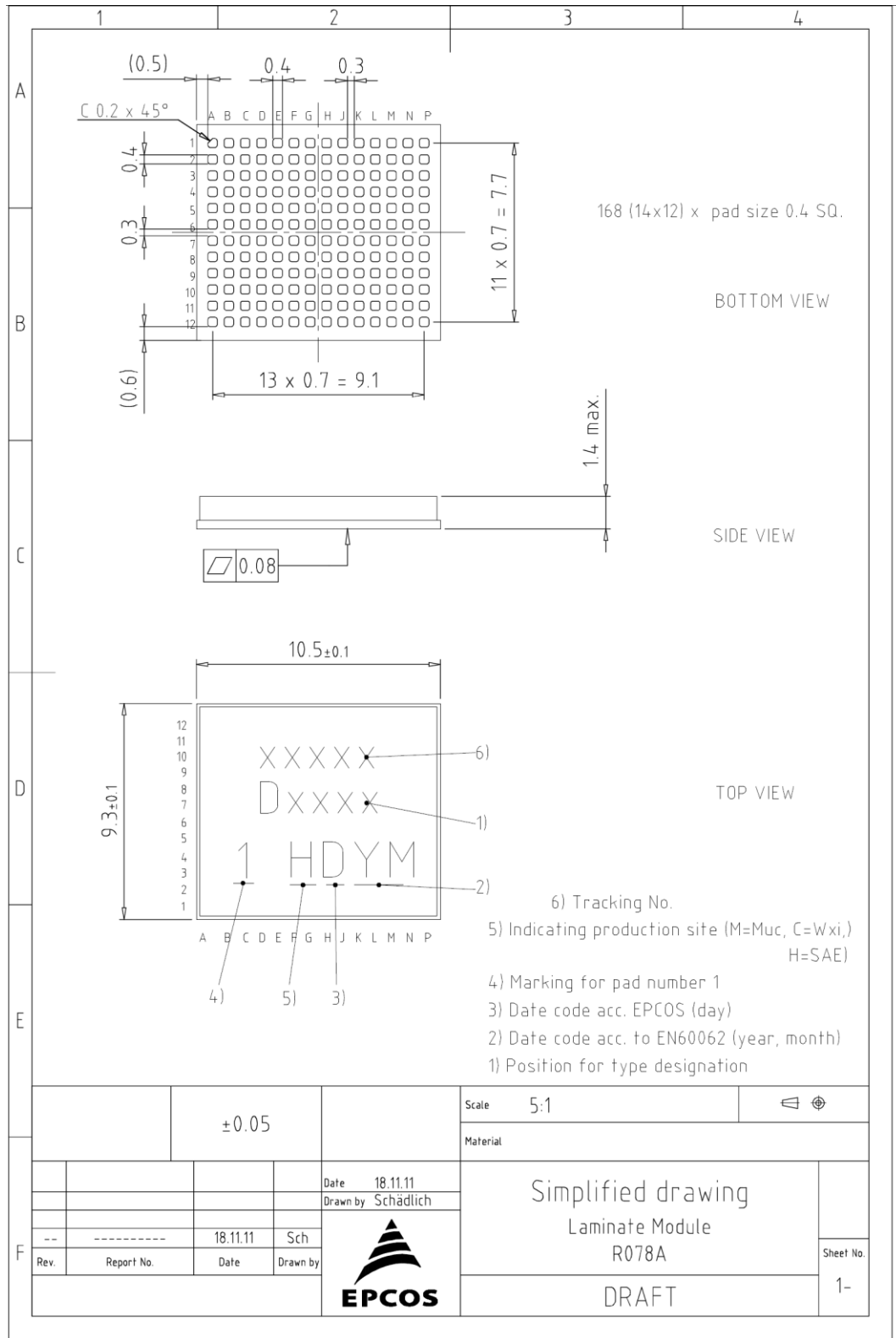

4.7 Schematic

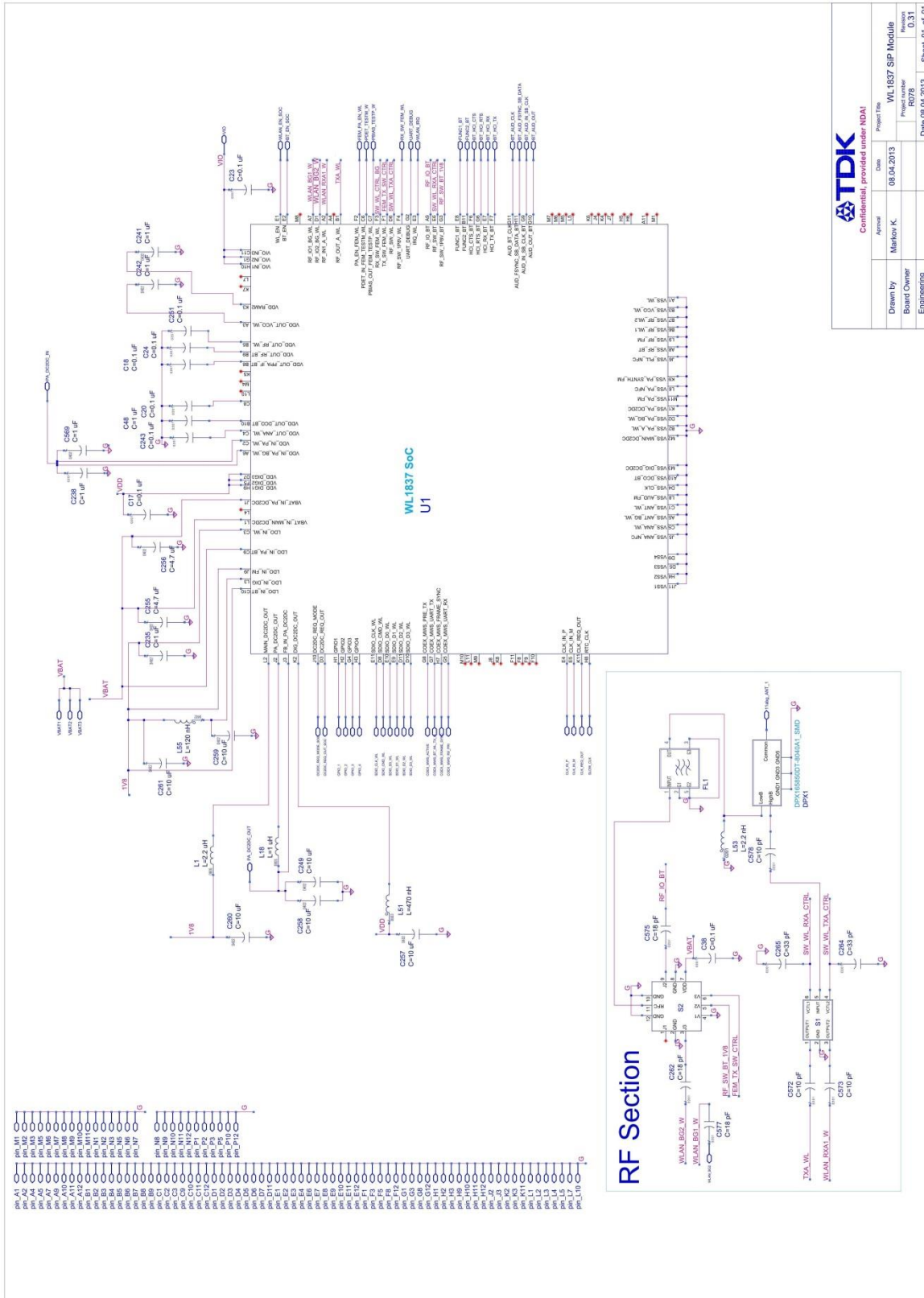

		Confidential, provided under NDA!	
		Project No.	WL1837 SiP Module
Approved	Date	08.04.2013	Revision
Drawn by	Board Owner	Manjov K.	R078
Engineering	Date	08.04.2013	Sheet 01 of 01

5 Lead-free Product Status

All Epcos modules in mass production are lead-free. This is achieved by using only materials with lead contamination below 1000 ppm. The applied lead-free solder alloy is the main source of Pb-contamination, which together gives Pb-levels much below 50 ppm per module.

A comprehensive qualification for these lead-free module packages has been done. The related AQTP documentation is available from Epcos on request.

6 Recommended Reflow Profile

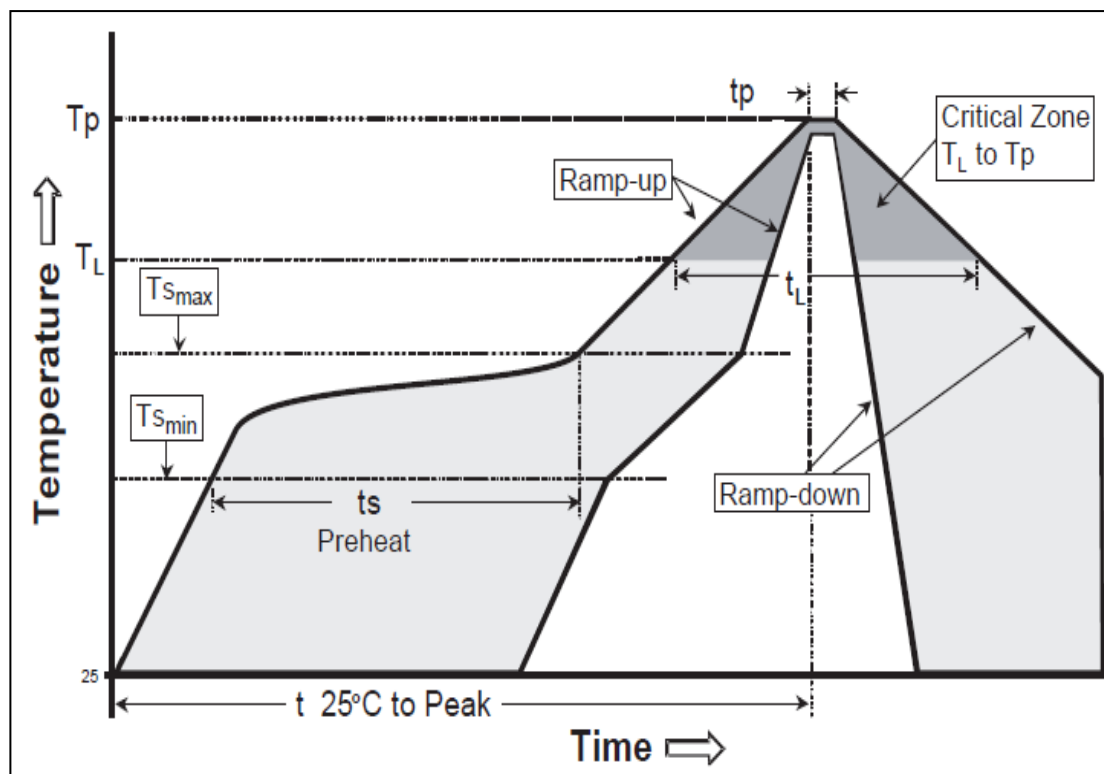

Profile Feature	Range
Average Ramp-Up Rate ($T_{s_{max}}$ to T_p)	3°C/second max.
Preheat: -Temperature Min ($T_{s_{min}}$) -Temperature Max ($T_{s_{max}}$) -Time ($t_{s_{min}}$ to $t_{s_{max}}$)	150°C 200°C 60-120 seconds
Time maintained above: -Temperature (T_L) -Time (t_L)	217°C 60-150 seconds
Peak Temperature (T_p)	245-250°C
Time within 5°C of actual Peak Temperature (T_p)	20-40 seconds
Ramp-Down Rate	6°C/second max.
Time 25°C to Peak Temperature	8 minutes max.

7 Packing Information

7.1.1 Packaging flow

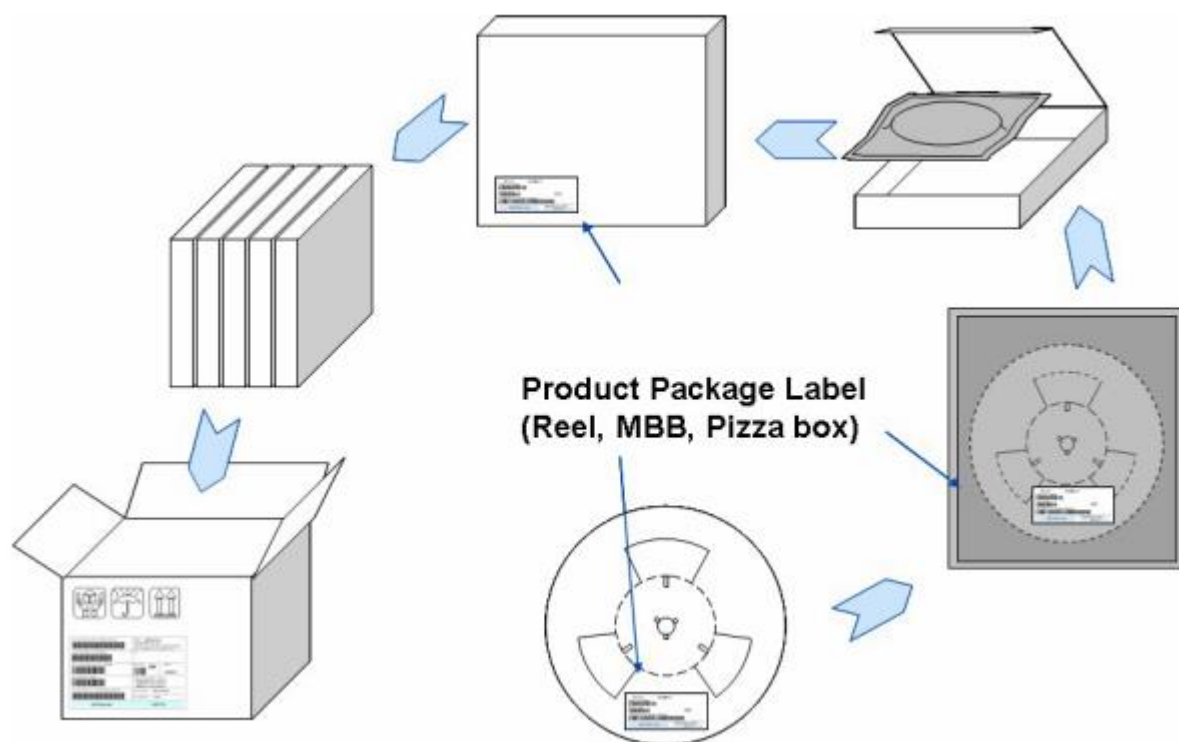

7.1.2 Outer Box

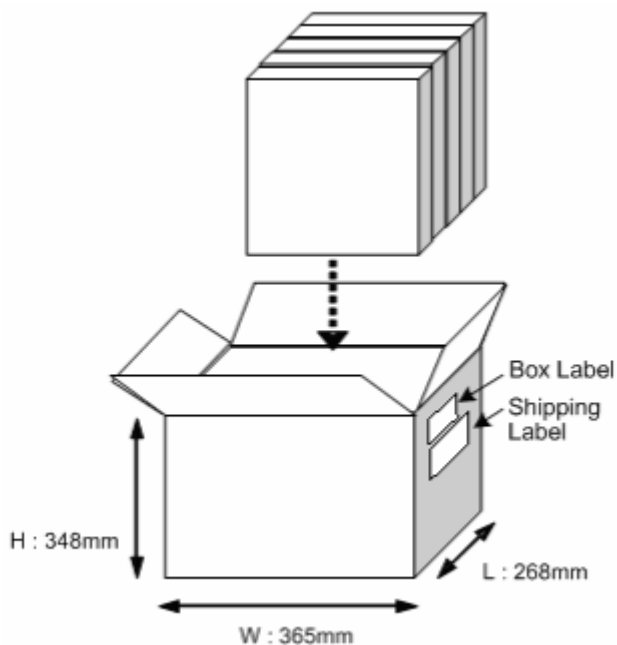

7.1.3 Inner Box

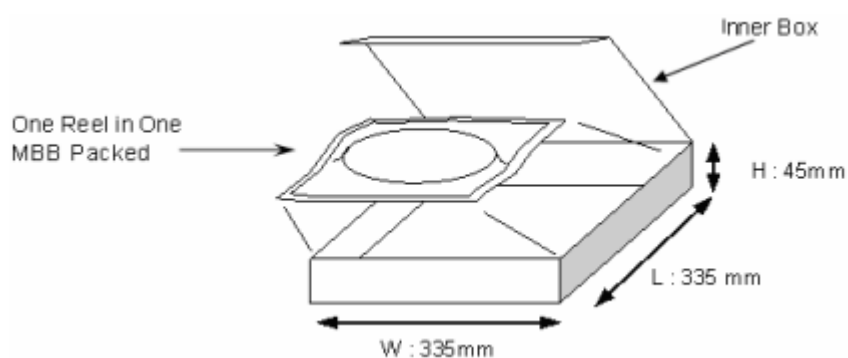

7.1.4 Tape drawing

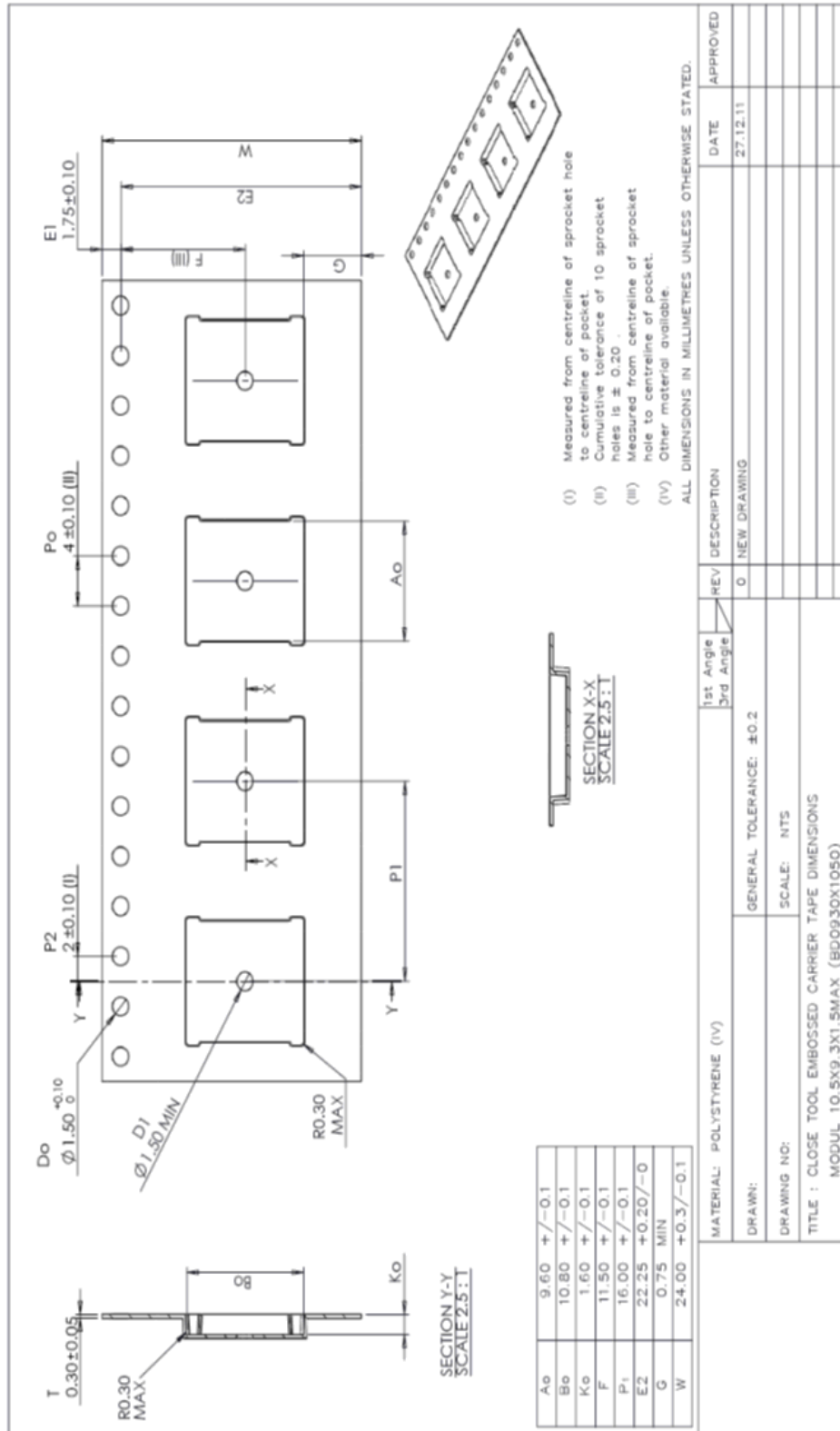

8 Revision History

Version	Date	Status	Note
0.1	7.1.2013	Preliminary	Initial
0.2	18.2.2013	Preliminary	Update from TI - FM support removed
0.3	18.4.2013	Preliminary	Update from TI - 5GHz WLAN RX MIMO support removed
0.3b	11.6.2013	Preliminary	LTE co-existence removed
0.4	9.10.2013	Preliminary	4.2.1.1 remove MIMO description adding ANT2 description remove MCS8,15,32 change spec for 1Mbps change spec for 54Mbps change spec for MCS7 4.2.1.3 remove MIMO description remove MCS8,15,32 change spec for all rate 4.2.2.1 remove MCS8,15,32 4.2.2.3 remove MCS32 adding Notes 4.6 update Package Mechanical Drawing
0.5	18.10.2013	Preliminary	Removed ANT function Removed 802. 11d,e,h,k,r function Removed Cisco support Removed 802.11v support 4.2.1.1 removed 11Mbps,6Mbps,MCS0 4.2.1.3 spec update 4.2.1.5 removed inactive current and update 4.2.2.1 removed 6Mbps,MCS0 4.2.2.3 spec update 4.2.2.5 Current Consumption spec update
0.6	25.10.2013	Preliminary	4.6 update Package Mechanical Drawing
0.7	07.03.2014	Preliminary	Updated 3.2.4.2 WLAN Power Up Sequence Updated Table 3-3 WLAN_IRQ (IRQ_WL) Updated 4.1.2 DC supply range Ambient operating temperature
0.8	30.5.2014	Preliminary	Removed 11n BW40MHz function Removed BLE function Removed external Xtal option Updated operation condition (3.4 to 4.3V / -15 to +55degree C) Updated all RF performance table Updated tape drawing

Version	Date	Status	Note
1.0	3.6.2014	Official Release	Updated 11n BW40MHz function Updated BLE function Updated external Xtal option
1.1	3.9.2014	Official Release	Changed 4.1.1 Absolute Maximum Ratings Operating ambient temperature range : -15 to +55 °C
1.2	25.9.2014	Official Release	Changed the template of the data sheet Updated operation temperature range : -30 to +85°C Updated 4.2.1.3 WLAN 2.4 GHz Transmitter power (1Mbps and 11Mbps) Updated 4.2.2.3 WLAN 5 GHz Transmitter power (MCS7)
1.3	9.12.2014	Official Release	Updated operation temperature range : -40 to +85°C

Display of ordering codes for EPCOS products

The ordering code for one and the same EPCOS product can be represented differently in data sheets, data books, other publications, on the EPCOS website, or in order-related documents such as shipping notes, order confirmations and product labels. **The varying representations of the ordering codes are due to different processes employed and do not affect the specifications of the respective products.** Detailed information can be found on the Internet under www.epcos.com/orderingcodes



Important notes

The following applies to all products named in this publication:





1. Some parts of this publication contain **statements about the suitability of our products for certain areas of application**. These statements are based on our knowledge of typical requirements that are often placed on our products in the areas of application concerned. We nevertheless expressly point out **that such statements cannot be regarded as binding statements about the suitability of our products for a particular customer application**. As a rule, EPCOS is either unfamiliar with individual customer applications or less familiar with them than the customers themselves. For these reasons, it is always ultimately incumbent on the customer to check and decide whether an EPCOS product with the properties described in the product specification is suitable for use in a particular customer application.
2. We also point out that **in individual cases, a malfunction of electronic components or failure before the end of their usual service life cannot be completely ruled out in the current state of the art, even if they are operated as specified**. In customer applications requiring a very high level of operational safety and especially in customer applications in which the malfunction or failure of an electronic component could endanger human life or health (e.g. in accident prevention or life-saving systems), it must therefore be ensured by means of suitable design of the customer application or other action taken by the customer (e.g. installation of protective circuitry or redundancy) that no injury or damage is sustained by third parties in the event of malfunction or failure of an electronic component.
3. **The warnings, cautions and product-specific notes must be observed.**
4. In order to satisfy certain technical requirements, **some of the products described in this publication may contain substances subject to restrictions in certain jurisdictions (e.g. because they are classed as hazardous)**. Useful information on this will be found in our Material Data Sheets on the Internet (www.epcos.com/material). Should you have any more detailed questions, please contact our sales offices.
5. We constantly strive to improve our products. Consequently, **the products described in this publication may change from time to time**. The same is true of the corresponding product specifications. Please check therefore to what extent product descriptions and specifications contained in this publication are still applicable before or when you place an order. We also **reserve the right to discontinue production and delivery of products**. Consequently, we cannot guarantee that all products named in this publication will always be available. The aforementioned does not apply in the case of individual agreements deviating from the foregoing for customer-specific products.
6. Unless otherwise agreed in individual contracts, **all orders are subject to the current version of the "General Terms of Delivery for Products and Services in the Electrical Industry" published by the German Electrical and Electronics Industry Association (ZVEI)**.
7. The trade names EPCOS, Alu-X, CeraDiode, CeraLink, CeraPlas, CSMP, CSSP, CTVS, DeltaCap, DigiSiMic, DSSP, FilterCap, FormFit, MiniBlue, MiniCell, MKD, MKK, MLSC, MotorCap, PCC, PhaseCap, PhaseCube, PhaseMod, PhiCap, PQSine, SIFERRIT, SIFI, SIKOREL, SilverCap, SIMDAD, SiMic, SIMID, SineFormer, SIOV, SIP5D, SIP5K, TFAP, ThermoFuse, WindCap are **trademarks registered or pending** in Europe and in other countries. Further information will be found on the Internet at www.epcos.com/trademarks.

Looking for pricing, stock, or lifecycle information?

Click below to explore more details on WIN SOURCE:

-  [View B30931D7020Y918 on WIN SOURCE](#)
-  [EPCOS \(TDK\) Information](#)

Optimize Your Supply Chain with WIN SOURCE Solutions

-  Global Sourcing Solution
-  Obsolete Management
-  Cost Control Management
-  Shortage Management
-  Alternative Solution
-  Excess Inventory Management