



**THE DATASHEET OF  
MAX30208EVSYS#**



## MAX30208 Evaluation System

Evaluates: MAX30208

### General Description

The MAX30208 evaluation system (EV system) provides a single platform to evaluate the MAX30208, a temperature sensor with  $\pm 0.1^{\circ}\text{C}$  accuracy. The EV system consists of two boards connected through headers, a MAX32630FTHR microcontroller board, and the MAX30208 interface board. Also included with the EV system is a flex PCB that holds the MAX30208 IC. The MAX32630FTHR contains the firmware necessary to use the PC GUI program and also provides power to the MAX30208 interface board. The MAX30208 interface board ships with jumpers preinstalled to allow quick evaluation of the MAX30208.

### Features

- Flexible PCB Design
  - Low Thermal Mass Allows for Fast Response Time
  - Sense Temperature Away from Extra Circuitry
- Easy to Reach Test Points
- Fully Assembled and Tested
- Windows<sup>®</sup> 7, 8, and 10-Compatible Software

### MAX30208 EV System Files

FILE	DESCRIPTION
MAX30208EVKitSetupV100.exe	PC GUI Program
MAX30208_SENSOR_FLEX.zip	Sch, BOM, PCB Layout
MAX3020x INTERFACE.zip	Sch, BOM, PCB Layout
MAX32630FTHR.zip	Sch, BOM, PCB Layout

The GUI and other documentation to use this EV System are available in the [MAX30208EVSYS# EV System Design Resources](#) tab.

Windows is a registered trademark and registered service mark of Microsoft Corporation.

### MAX30208 EV System Photo



### Quick Start

#### Required Equipment

**Note:** In the following sections, software-related items are identified by bold text. Text in **bold** refers to items directly from the install of EV system software. Text that is **bold and underlined** refers to items from the Windows operating system.

- MAX30208 Sensor Flex
- MAX3020x interface board
- MAX32630FTHR
- Micro-USB cable
- Windows PC with USB port
- MicroSD card (optional)
- Lithium-ion battery (optional)

#### Procedure

The EV system is tested and ships in three pieces: MAX30208 Sensor Flex, MAX3020x interface board, and MAX32630FTHR.

Follow the steps below to verify board operation:

- 1) Plug the MAX32630FTHR into the MAX3020x Interface Board.
- 2) Connect the MAX30208 Sensor Flex to J9 on the interface board, ensuring that the contact pads are on the bottom.
- 3) Set the EV system hardware on a nonconductive surface to ensure nothing on the PCBs short together.
- 4) Connect the EV system hardware to a PC with the provided USB cable. Attach the micro-USB end to the MAX32630FTHR and the other end to the PC. LED D1 on the MAX32630FTHR begins blinking light blue.

**Ordering Information** appears at end of data sheet.

- 5) Windows should automatically begin installing the necessary device driver. Once the driver installation is complete, a Windows message appears near the system icon menu, indicating the hardware is ready to use. Do not attempt to run the GUI prior to this message. If you do, then close the application and restart it once the driver installation is complete. On some versions of Windows, administrator privileges might be required to install the USB device.
- 6) Once the device drivers have been installed, download the software from [MAX30208EVSYS#\\_EV\\_system\\_Design\\_Resources](#) tab and extract it to a temporary folder.
- 7) Open the extracted ZIP folder and double-click the .EXE file to run the installer. If a message box stating **The publisher could not be verified. Are you sure you want to run this software?** appears, select the **Yes** option.
- 8) When the installer GUI appears, click **Next**. Select the installation paths and whether a shortcut should be created on the desktop. When prompted, press **Install**. Once complete, click **Close**.
- 9) If a shortcut was created, double-click on the shortcut to start the GUI. Alternatively, go to **Start | All Programs**. Look for the **MAX30208EVKitTool** folder and click on the **MAX30208EVKitTool.EXE** file inside the folder.
- 10) When the GUI appears, the text in the right field of the bottom status bar displays **Connected**. If the GUI displays **Not Connected**, ensure the flex PCB is properly connected and power-cycle the MAX30208 EV system.

## Detailed Description of Software

### Software Startup

If the EV system is connected while the software is open, the software first initializes the hardware to communicate. The software then reads the device registers and updates all the associated control fields displayed on the GUI.

Once an EV system is connected, the GUI automatically sets the device registers and begins taking temperature measurements.

If the EV system is not connected on startup, the GUI starts up with no devices displayed in the **Devices** section of the GUI and no temperature reading in the **Selected Device** section. The status bar at the bottom of the GUI states **Not Connected**.

### ToolStrip Menu Bar

The **ToolStrip** menu bar ([Figure 1](#)) is located at the top of the GUI window. This bar comprises the **File**, **Device**, **Logging**, and **Help** menus whose functions are detailed in the following sections.

#### File Menu

The **File** menu contains the option to exit out of the GUI program.

#### Device Menu

The **Device** menu provides the ability to connect or disconnect an EV system to the GUI. If a board is disconnected while the GUI is open the GUI displays **Hardware Not Connected** in the lower right corner. If the device is then plugged back in, the user can navigate to the **Device** menu and select **Connect**. If successful, the bottom right corner of the GUI reads **Device Connected**.

#### Logging Menu

The **Logging** menu provides two ways to export each data sample that is being measured by the device. The first logging option is **File Logging**. Selecting either log option opens a prompt asking to select a device from which to log data. Next, a prompt appears that allows the user to choose a name for the comma-separated value (CSV) log file, as well as the location to save the generated file. [Figure 2](#) and [Figure 3](#) show the GUI when creating a log file. The GUI disables file logging after one monitoring session and a new file must be generated through the **Logging** menu to log another dataset.

The second logging option is **MicroSD Logging**. MicroSD logging provides the ability to operate the EV system without a connection to a host PC or power supply. First, insert a microSD card into the connector on the underside of the MAX32630FTHR. After selecting the logging interval and writing the selection to the microSD card as seen in [Figure 4](#), connect a 3.7V lithium-ion battery with a JST PH connector to the MAX32630FTHR and then disconnect the board from the host PC. Refer to the MAX32630FTHR data sheet for details on connecting a Li+ battery. Press SW2 to start saving measurements to the SD card. Pressing SW2 again stops measurements.

To transfer the logged data from the MicroSD card to a file on a PC, reconnect the MAX30208 EV system to the PC and select microSD card logging from the **Logging** menu. Select the **Save to File** option and a prompt appears to name the log file ([Figure 3](#)). For subsequent logging sessions, **Clear Log** should be pressed on the **Setup MicroSD Logging** screen to prevent multiple datasets from being recorded to the same log file.



Figure 1. ToolStrip Menu Bar

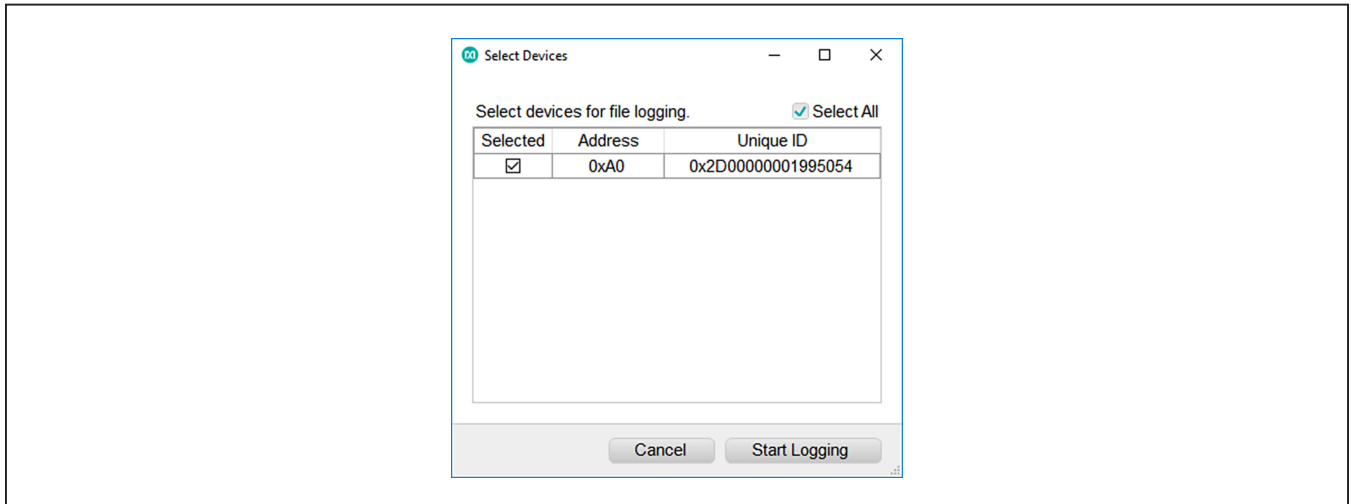

Figure 2. Device Select Screen for Logging

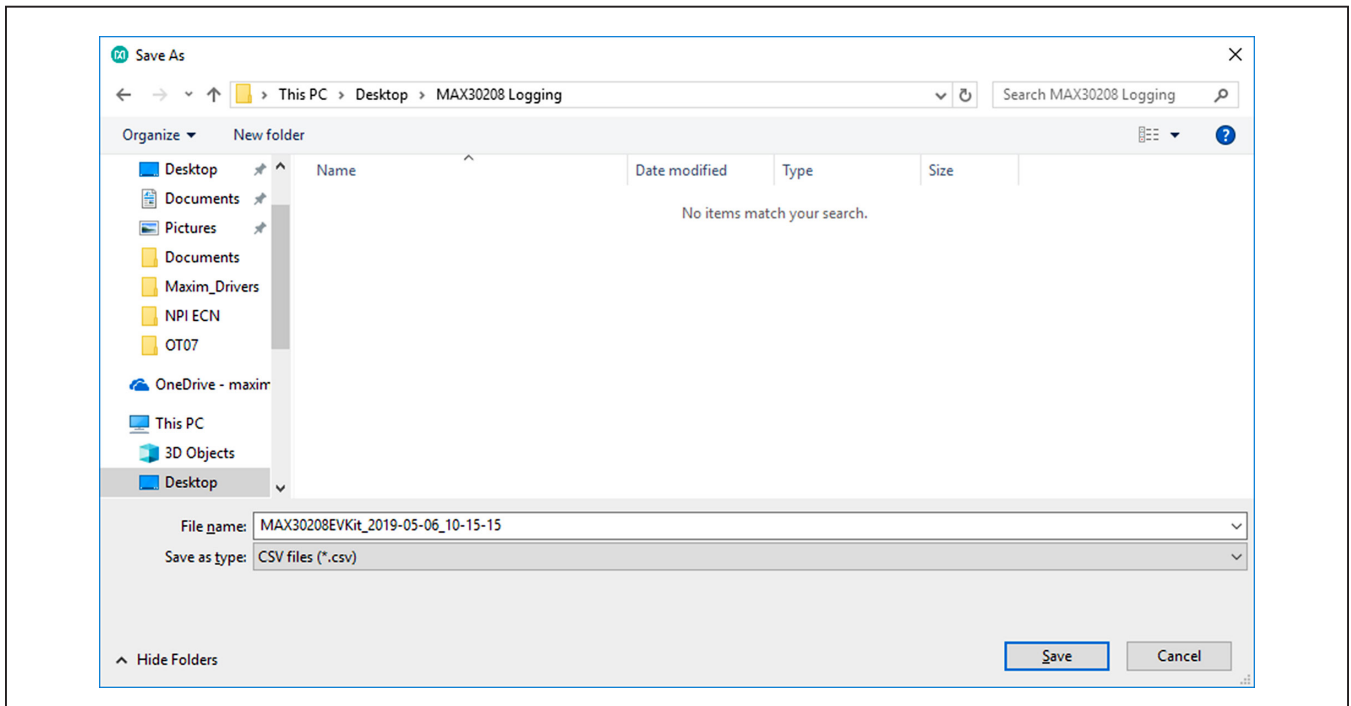

Figure 3. File Naming Screen for Logging

### Help Menu

The **About** option displays the GUI splash screen, which names the GUI version being used.

### Tab Control

The main interface structure of the GUI consists of a tab control where each tab contains controls relevant to various blocks of the device. Changing these interactive controls triggers a write operation to the MAX30208 to update the register contents. Likewise, these controls are refreshed when reading from the device. The **Register Map** tab allows the user to read and write to individual registers.

### General Tab

The **General Tab** (Figure 5) displays a general overview of the MAX30208. The tab provides a list of devices currently connected, temperature data for a selected device, as well as controls for select registers.

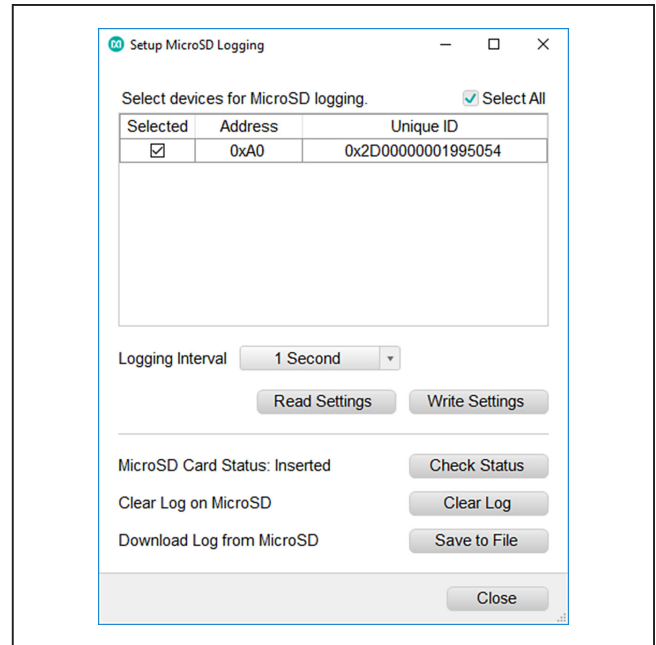

Figure 4. MicroSD Logging Prompt

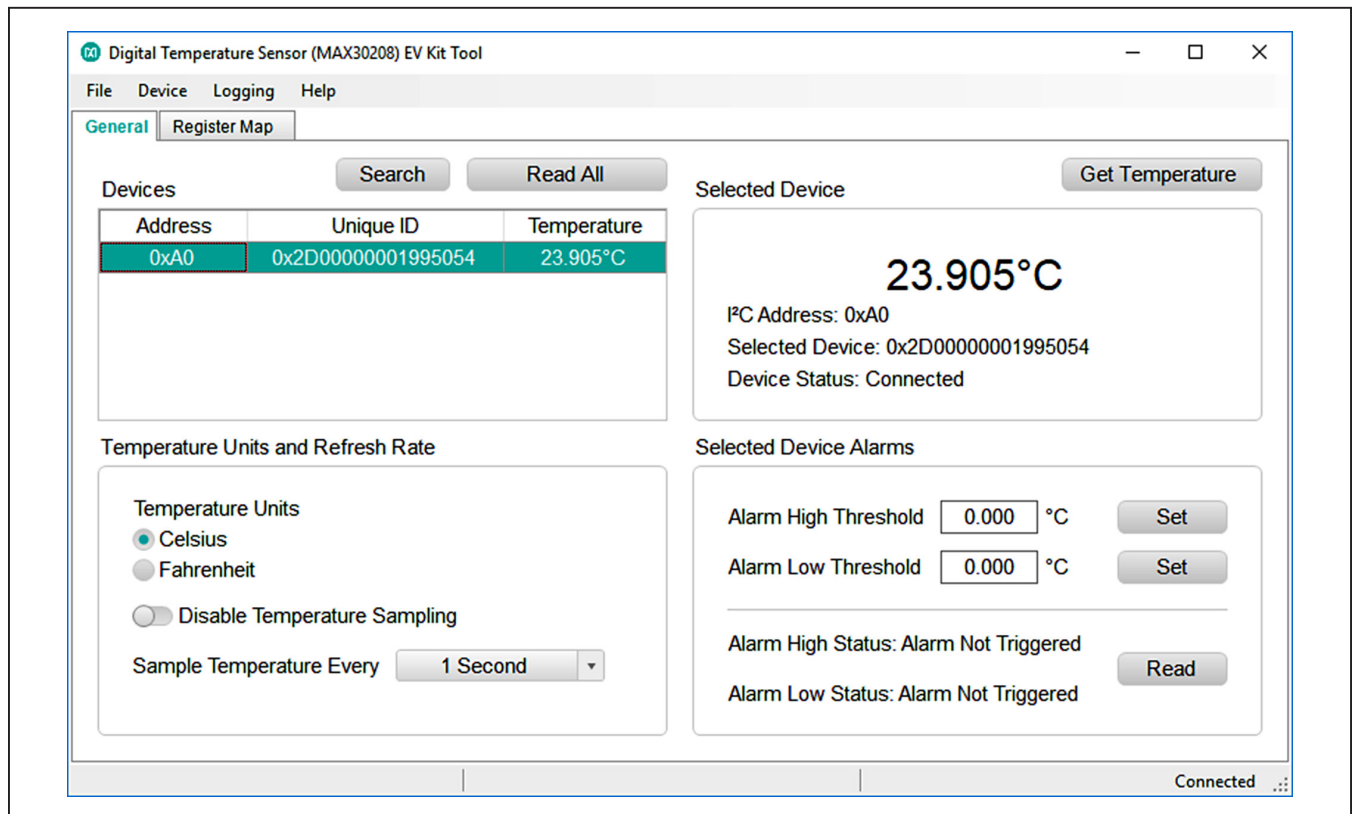

Figure 5. General Tab

### Register Map Tab

The **Register Map** tab (Figure 6) provides more direct access to the internal registers of the MAX30208. From this tab, it is possible to read the contents of individual registers and to manually enter the desired bit settings for a write operation. For the register address selected in the table on the left, the contents are displayed at the bottom of the tab and visualized as bold or non-bold bit names. When a bit is bold, its value is 1. Otherwise, the bit is 0. Full descriptions of each bit are available in the table on the right for quick reference. Pressing **Read** reads the selected register highlighted in teal. Pressing **Read All** reads all registers and updates their values in the **Register Map** tab. To write to a register, set the desired bit values by clicking on the bit names to make bold or non-bold and then press **Write**.

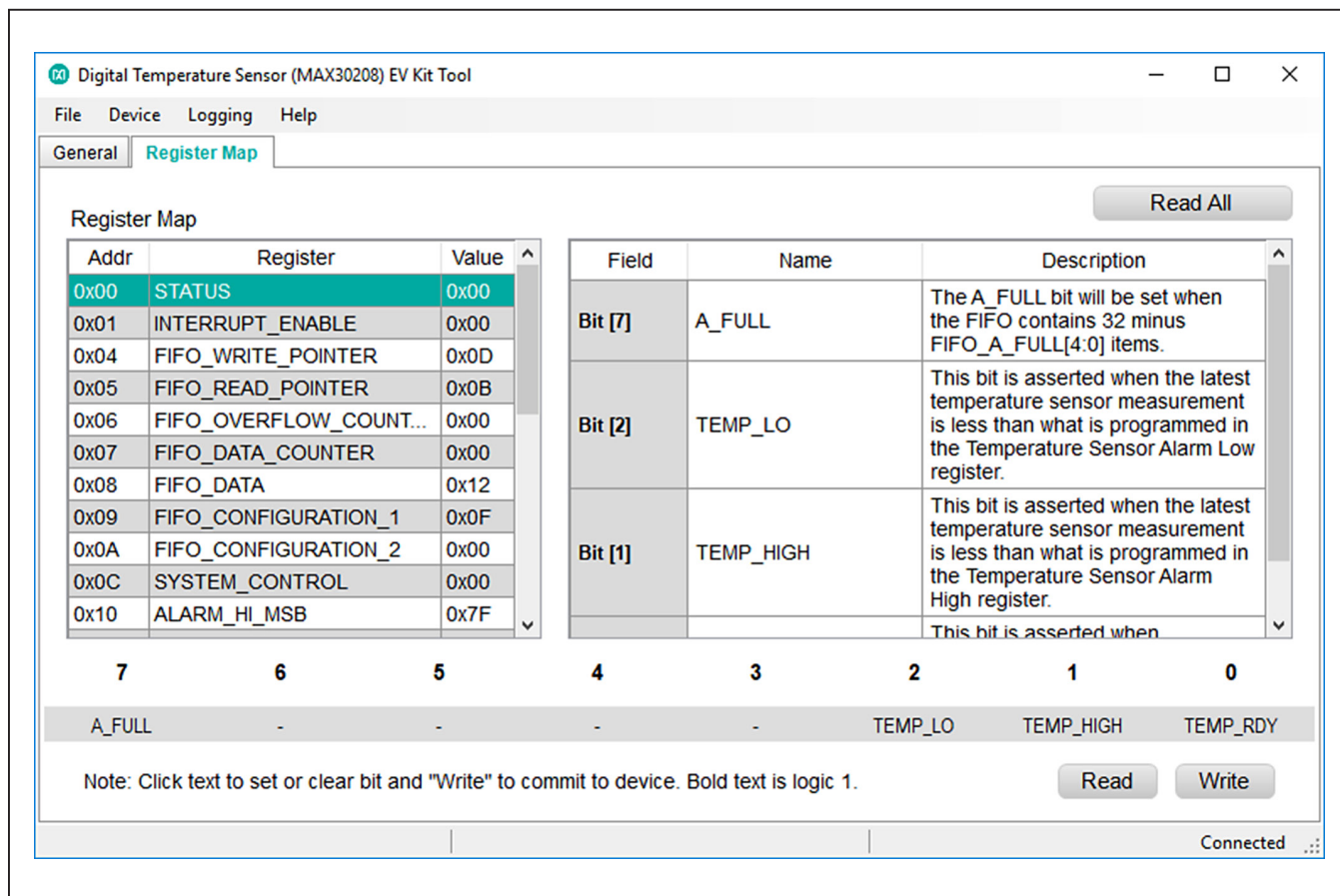

Figure 6. Register Map Tab

## Detailed Description of Hardware

The MAX30208 EV system provides a single platform to evaluate the functionality and features of the MAX30208. The board contains jumpers to test the MAX30208 under several conditions. A list of all jumpers and their respective functions is available in [Table 1](#).

**Table 1. Description of Jumpers**

JUMPER	DESCRIPTION
J3	Connect SCL to 4.7kΩ pullup
J4	Connect SDA to 4.7kΩ pullup
J5	Connect VCC to 1.8V of the MAX32630FTHR
J6	Connect to I <sup>2</sup> C position
J7/J8	Connect SDA/SCL from MAX23630FTHR to MAX30208

## Component Suppliers

SUPPLIER	WEBSITE
Keystone	www.keyelco.com
Maxim Integrated	www.maximintegrated.com
Molex	www.molex.com
Murata	www.murata.com
Panasonic	www.industrial.panasonic.com
Samtec	www.samtec.com
Sullins	www.sullinscorp.com
TE Connectivity	www.te.com

**Note:** Indicate that you are using the MAX30208 when contacting these component suppliers.

The EV system utilizes the MAX32630FTHR Arm® Cortex®-M4F microcontroller for wearables to interface with the GUI and optionally provides power to the MAX30208. The MAX32630FTHR operates either from a host PC or directly from a Li+ battery. If an SD card is present in the MAX32630FTHR, pressing SW2 on the MAX32630FTHR initiates measurements and saves log files to the SD card. Logging is stopped by pressing SW2 a second time.

## Powering the EV system

The MAX30208 EV system is powered directly from the MAX32630FTHR through either a lithium-ion battery or a USB to Micro-USB cable. J5 must be connected to the 1.8V option in order to supply power from the MAX32630FTHR. J7 and J8 must each have a shunt connected to connect the serial data (SDA) and serial clock (SCL) lines from the MAX32630FTHR to the MAX30208 IC. J10 can be used to connect the interface board, through wires to another board that contains the MAX30208 IC.

J10 can also be used to connect a microcontroller other than the MAX32630FTHR to the MAX30208 IC.

## Ordering Information

PART	TYPE
MAX30208EVSYS#	EV System

#Denotes RoHS compliance.

Arm and Cortex are registered trademarks of Arm Limited (or its subsidiaries) in the US and/or elsewhere.

## MAX30208EVSYS# EV System Bill of Materials

Other documentation to use this EV System are available in the [MAX30208EVSYS# EV System Design Resources](#) tab.

### MAX30208 Sensor Flex Bill of Materials

ITEM	REF_DES	DNI/DNP	QTY	MFG PART #	MANUFACTURER	VALUE	DESCRIPTION
1	C1	—	1	GRM033C81E104KE14	MURATA	0.1UF	CAPACITOR; SMT (0201); CERAMIC CHIP; 0.1µF; 25V; TOL = 10%; TG = -55°C TO +105°C; TC = X6S
2	U1	—	1	MAX30208	MAXIM	MAX30208	EVKIT PART - IC; MAX30208; PACKAGE OUTLINE DRAWING: 21-100265; LGA10
3	PCB	—	1	MAX30208SENSORFLEX	MAXIM	PCB	PCB:MAX30208SENSORFLEX
4	J1	DNP	0	5051100692_EDGE	MOLEX	5051100692_EDGE	CONNECTOR; FEMALE; SMT; FD19 SERIES; RIGHT ANGLE; 6PINS;
<b>TOTAL</b>			<b>3</b>				

### MAX30208 Interface Board Bill of Materials

ITEM	REF_DES	QTY	MFG PART #	MANUFACTURER	VALUE	DESCRIPTION	
1	3VP3, V1P8	2	5005	KEYSTONE	N/A	TEST POINT; PIN DIA = 0.125IN; TOTAL LENGTH = 0.35IN; BOARD HOLE = 0.063IN; RED; PHOSPHOR BRONZE WIRE SILVER PLATE FINISH;	
2	GND, SCL, SDA, VDD/DQ	4	5006	KEYSTONE	N/A	TEST POINT; PIN DIA = 0.125IN; TOTAL LENGTH = 0.35IN; BOARD HOLE = 0.063IN; BLACK; PHOSPHOR BRONZE WIRE SILVER PLATE FINISH;	
3	J1	1	PPPC161LFBN-RC	SULLINS ELECTRONICS CORP.	PPPC161LFBN-RC	CONNECTOR; FEMALE; THROUGH HOLE; LFB SERIES; 2.54MM CONTACT CENTER; STRAIGHT; 16PINS	
4	J2	1	PPPC121LFBN-RC	SULLINS ELECTRONICS CORP.	PPPC121LFBN-RC	CONNECTOR; FEMALE; THROUGH HOLE; HEADER FEMALE; STRAIGHT; 12PINS	
5	J3, J4	2	TSW-102-07-T-S	SAMTEC	TSW-102-07-T-S	CONNECTOR; THROUGH HOLE; TSW SERIES; SINGLE ROW; STRAIGHT; 2PINS; -55°C TO +105°C	
6	J5, J7, J8	3	TSW-103-07-L-S	SAMTEC	TSW-103-07-L-S	CONNECTOR; THROUGH HOLE; SINGLE ROW; STRAIGHT; 3PINS	
7	J6	1	TSW-103-07-L-D	SAMTEC	TSW-103-07-L-D	CONNECTOR; MALE; THROUGH HOLE; THROUGH HOLE 0.025 POST HEADER; STRAIGHT; 6PINS	
8	J9	1	5051100692	MOLEX	5051100692	CONNECTOR; FEMALE; SMT; FD19 SERIES; RIGHT ANGLE; 6PINS	
9	J10	1	282834-6	TE CONNECTIVITY	282834-6	CONNECTOR; FEMALE; THROUGH HOLE; TERMINAL BLOCK PCB MOUNT SIDE WIRE ENTRY STACKING; STRAIGHT; 6PINS	
10	R1, R2	2	ERJ-2RKF4701	PANASONIC	4.7K	RESISTOR; 0402; 4.7KΩ; 1%; 100PPM; 0.10W; THICK FILM	
11	U1	1	DS2484R+	MAXIM	DS2484R+	IC; INFC; SINGLE-CHANNEL 1-WIRE MASTER WITH ADJUSTABLE TIMING AND SLEEP MODE; SOT23-6	
12	PCB	1	MAX3020XINTERFACE	MAXIM	PCB	PCB:MAX3020XINTERFACE	
<b>TOTAL</b>			<b>20</b>				

### MAX30208EVSYS# EV System Schematic

Other documentation to use this EV System are available in the [MAX30208EVSYS# EV System Design Resources](#) tab.

### MAX30208 Sensor Flex Schematic

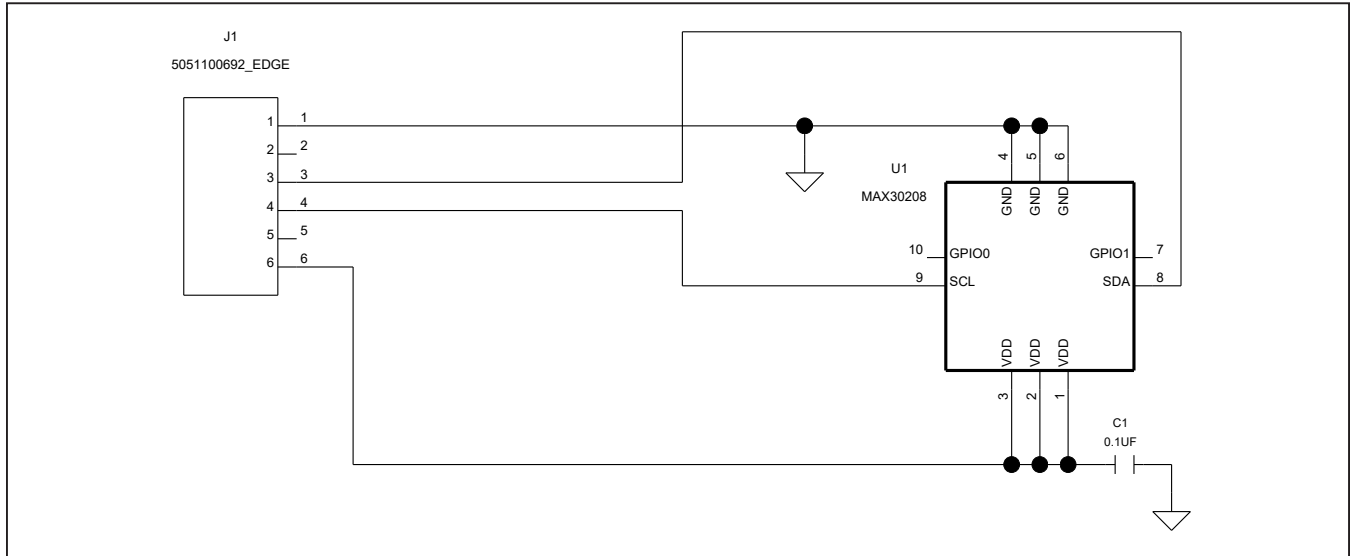



### MAX30208EVSYS# EV System PCB Layout Diagrams

Other documentation to use this EV System are available in the [MAX30208EVSYS# EV System Design Resources](#) tab.

#### MAX30208 Sensor Flex PCB Layout

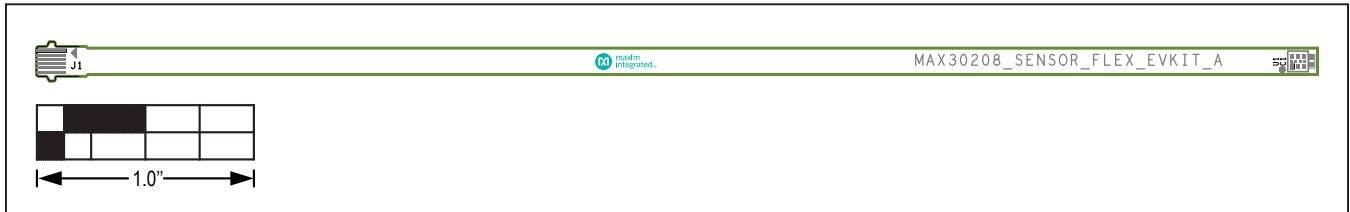

MAX30208 EV Kit Sensor Flex PCB Layout—Silk Top

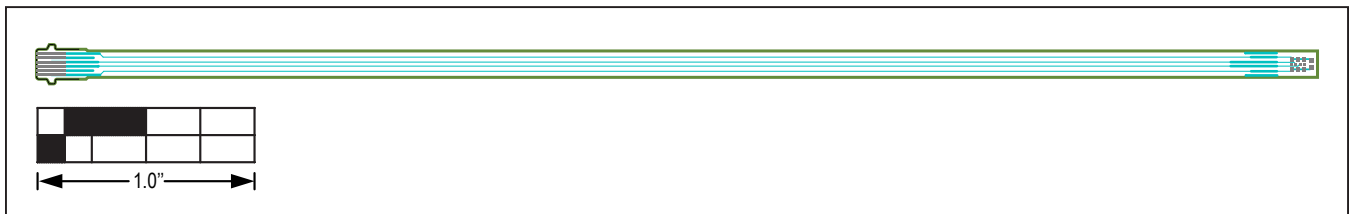

MAX30208 EV Kit Sensor Flex PCB Layout—Top View

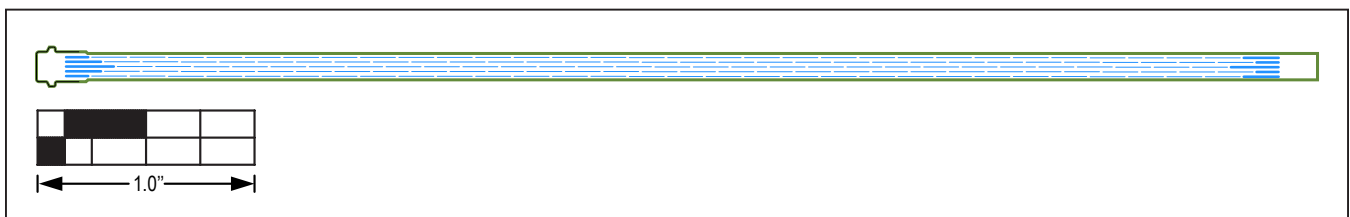

MAX30208 EV Kit Sensor Flex PCB Layout—Bottom View

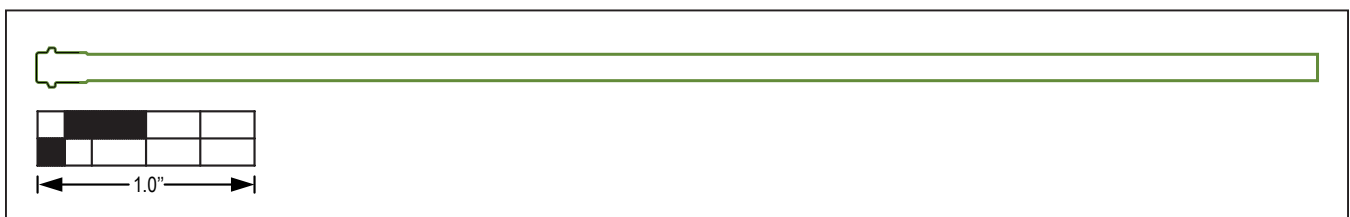

MAX30208 EV Kit Sensor Flex PCB Layout—Bottom Silkscreen

**MAX30208EVSYS# EV System PCB Layout Diagrams (continued)**

**MAX30208 Interface Board PCB Layout**

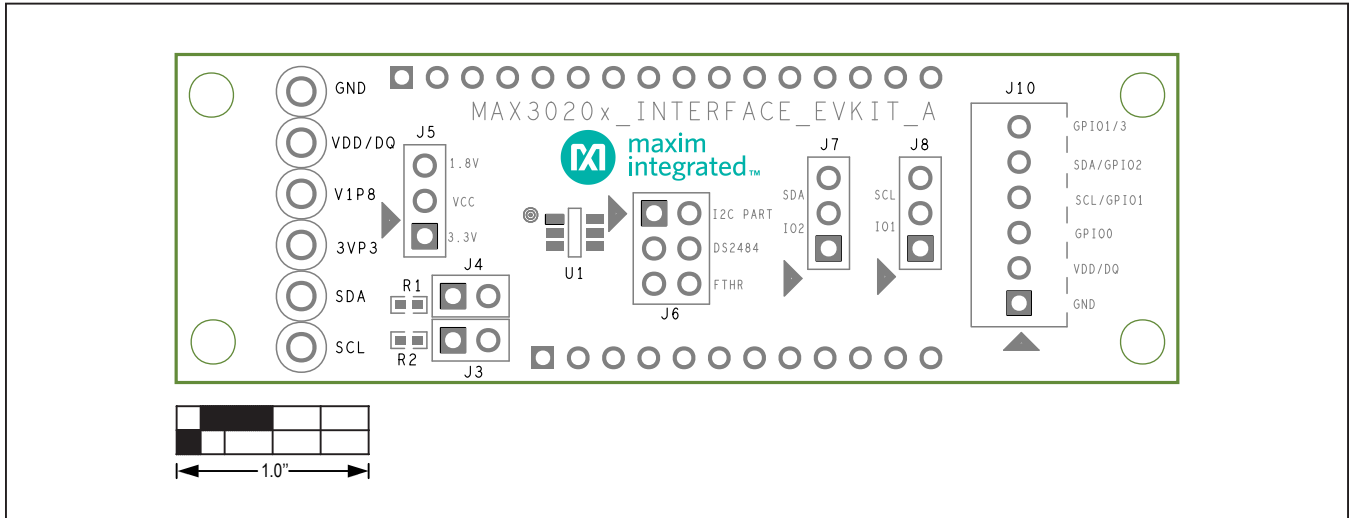

MAX30208 EV Kit Interface Board PCB Layout—Silk Top

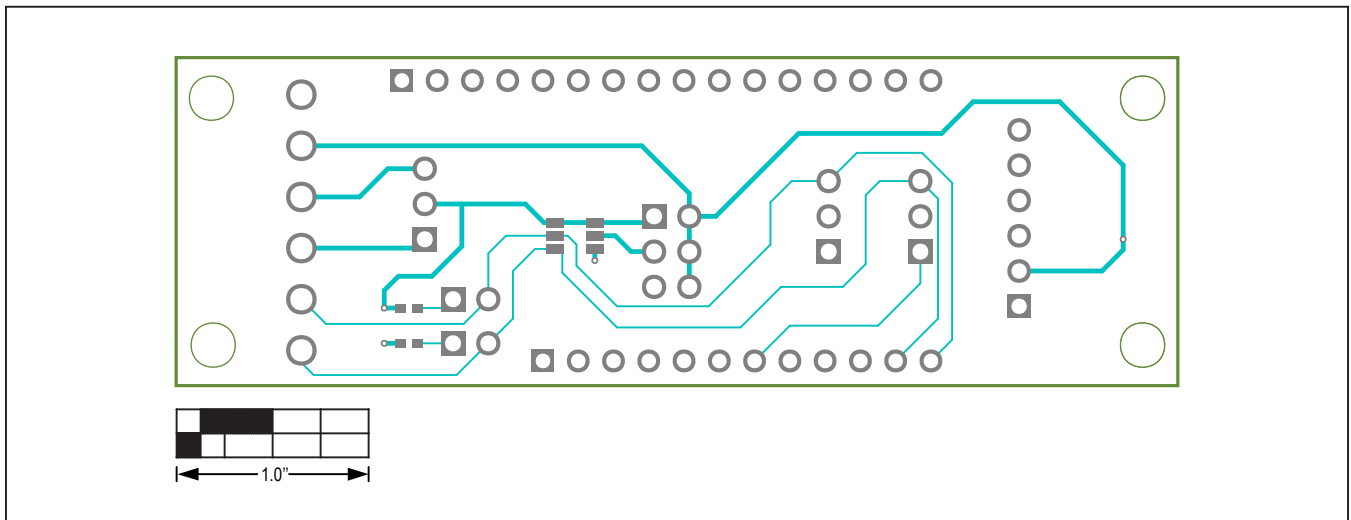

MAX30208 EV Kit Interface Board PCB Layout—Top View

**MAX30208EVSYS# EV System PCB Layout Diagrams (continued)**

**MAX30208 Interface Board PCB Layout (continued)**

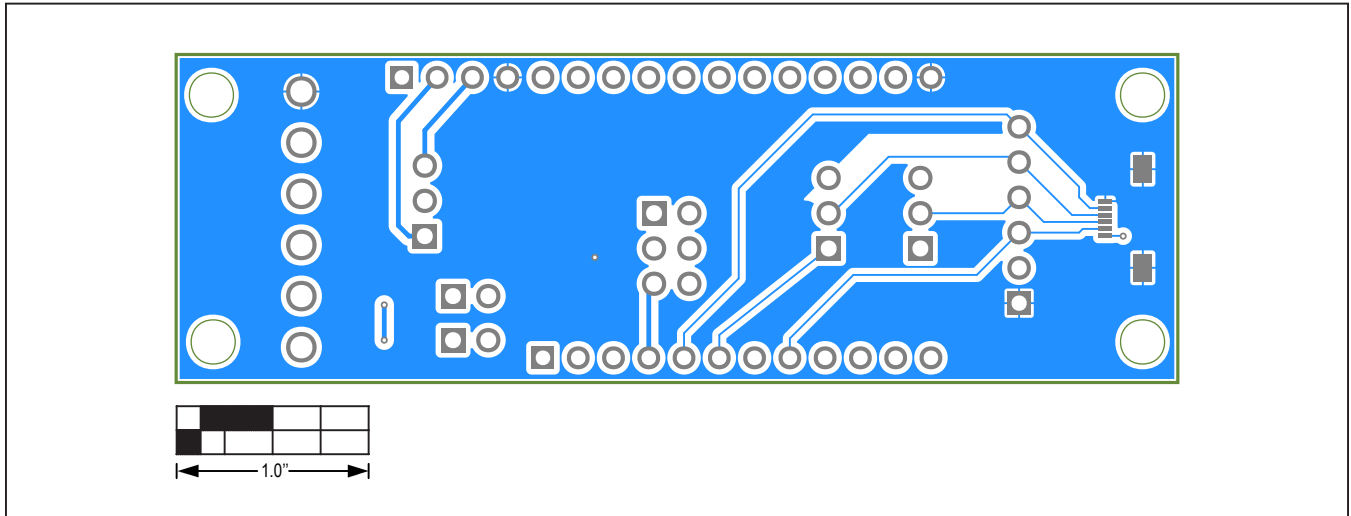

MAX30208 EV Kit Interface Board PCB Layout—Bottom View

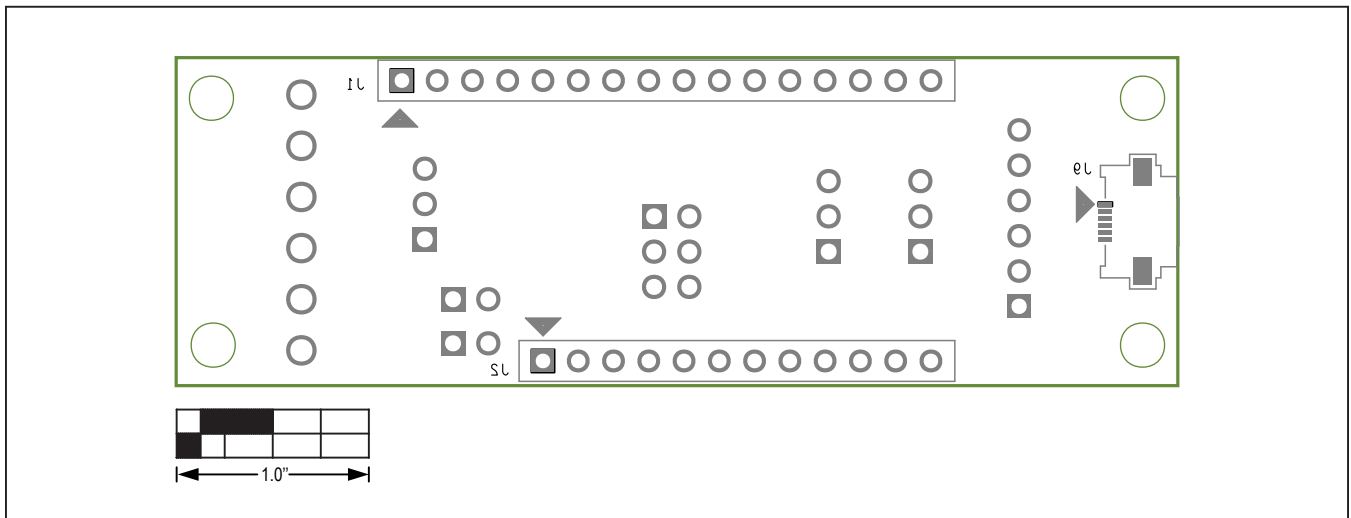

MAX30208 EV Kit Interface Board PCB Layout—Bottom Silkscreen

## Revision History

REVISION NUMBER	REVISION DATE	DESCRIPTION	PAGES CHANGED
0	6/19	Initial release	—

For pricing, delivery, and ordering information, please visit Maxim Integrated's online storefront at <https://www.maximintegrated.com/en/storefront/storefront.html>.

*Maxim Integrated cannot assume responsibility for use of any circuitry other than circuitry entirely embodied in a Maxim Integrated product. No circuit patent licenses are implied. Maxim Integrated reserves the right to change the circuitry and specifications without notice at any time.*

## Looking for pricing, stock, or lifecycle information?

Click below to explore more details on WIN SOURCE:

- ⊖ [View MAX30208EVSYS# on WIN SOURCE](#)
- ⊖ [Maxim Integrated Information](#)

## Optimize Your Supply Chain with WIN SOURCE Solutions

- ✓ Global Sourcing Solution
- ✓ Obsolete Management
- ✓ Cost Control Management
- ✓ Shortage Management
- ✓ Alternative Solution
- ✓ Excess Inventory Management