



**THE DATASHEET OF
AOZ1334DI-02**



General Description

The AOZ1334DI-02 is a single channel load switch with very low on-resistance in a small package. It contains an n-channel MOSFET for up to 5.5V input voltage operation and 10A current channel with 5V bias supply. The load switch is controlled by a low voltage control signal through ON pin.

The AOZ1334DI-02 integrates an internal 220Ω load resistor for quick output discharge when load switch is off.

The AOZ1334DI-02 is available in a 3mm x 3mm DFN-8L package with bottom thermal pad and is rated over a -40°C to +85°C ambient temperature range.

Features

- 0.8V to 5.5V input voltage range
- 10A continuous current
- Low $R_{DS(ON)}$ internal NFETs
– 3.6mΩ at $V_{BIAS} = 5V$, $V_{IN} = 1.05V$
- 60μA low quiescent current
- 0.5ms turn on rise time at $V_{BIAS} = 5V$ and $V_{IN} = 1.05V$
- 2.5V to 5.5V bias voltage
- Integrated quick output discharge resistor
- Thermally enhanced 3mm x 3mm DFN-8L package

Applications

- Portable computers
- Ultrabooks
- Tablet PCs
- Set top boxes
- LCD TVs
- Telecom/Networking/Datacom equipment
- SSD
- Consumer electronics



Typical Application

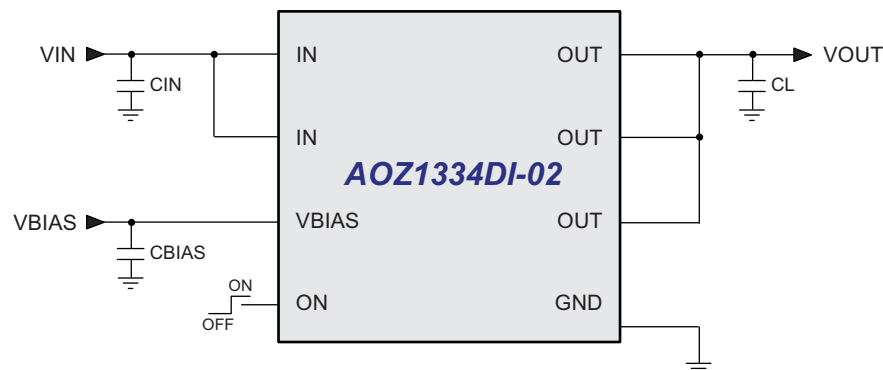

Ordering Information

Part Number	Temperature Range	Package	Environmental
AOZ1334DI-02	-40°C to +85°C	3mm x 3mm DFN-8L	Green



All AOS products are offered in packages with Pb-free plating and compliant to RoHS standards.

Please visit www.aosmd.com/media/AOSGreenPolicy.pdf for additional information.

Pin Configuration

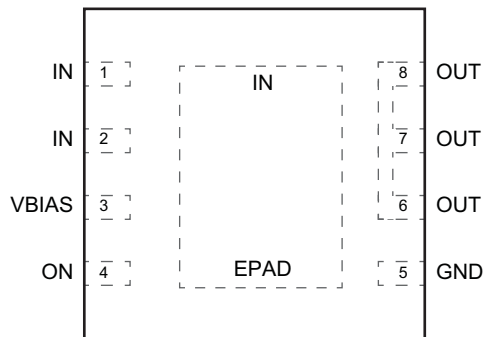

3mm x 3mm DFN-8
(Top View)

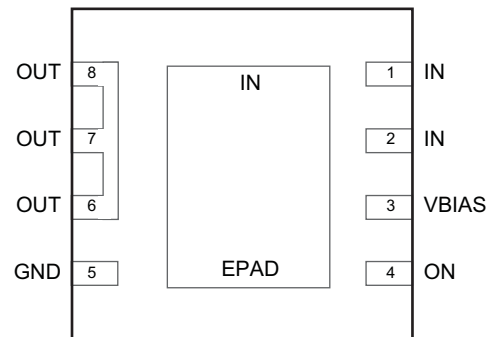

3mm x 3mm DFN-8
(Bottom View)

Pin Description

Pin Number	Pin Name	Pin Function
1, 2, EPAD	IN	Load Switch Input. Bypass capacitor is recommended to minimize input voltage dip. Recommended voltage range of this pin is 0.8V to 5.5V to obtain optimal R _{ON} .
3	VBIAS	Bias Voltage. Power supply input for the device. Recommended voltage range is 2.5V to 5.5V.
4	ON	Active High Switch Control Input. Do not leave floating.
5	GND	Ground.
6, 7, 8	OUT	Load switch output.

Functional Block Diagram

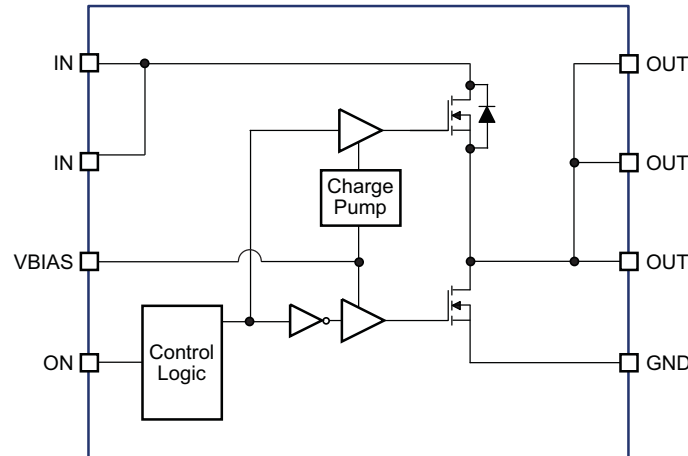

Absolute Maximum Ratings

Exceeding the Absolute Maximum ratings may damage the device.

Parameter	Rating
IN, ON, VBIAS, OUT to GND	-0.3V to 6V
Junction Temperature (T_J)	+150°C
Storage Temperature (T_S)	-65°C to +150°C
ESD Rating HBM/CDM	2kV/1kV

Recommend Operating Ratings

The device is not guaranteed to operate beyond the Maximum Operating Ratings.

Parameter	Rating
Supply Voltage (V_{IN})	5.5V
Ambient Temperature (T_A)	-40°C to +85°C
Package Thermal Resistance 3x3 DFN-8 (θ_{JC}) 3x3 DFN-8 (θ_{JA})	8°C/W 60°C/W

Electrical Characteristics

$T_A = 25^\circ\text{C}$, $V_{BIAS} = 5\text{V}$, $V_{IN} = 1.05\text{V}$, unless otherwise specified. Specifications in **BOLD** indicate a temperature range of -40°C to +85°C.

Symbol	Parameter	Conditions	Min.	Typ.	Max.	Units
V_{IN}	IN Supply Voltage	$V_{ON} = 5\text{V}$	0.8	1.05	5.5	V
V_{BIAS}	VBIAS Supply Voltage		2.5	5	5.5	V
I_D	Maximum Continuous Current	$V_{ON} = 5\text{V}$		10		A
I_{PLS}	Maximum Pulsed Switch Current	$V_{IN} = V_{ON} = 5\text{V}$ Pulse < 300 μs , 2% Duty Cycle		12		A
I_q	Quiescent Supply Current of V_{BIAS}	$I_{OUT} = 0\text{V}$, $V_{ON} = 5\text{V}$		60		μA
I_{OFF}	VBIAS Shutdown Supply Current	$V_{ON} = 0\text{V}$, $V_{OUT} = 0\text{V}$			2	μA
I_{INOFF}	IN Shutdown Supply Current	$V_{ON} = 0\text{V}$, $V_{OUT} = 0\text{V}$			2	μA
I_{ON}	ON Leakage Current	$V_{ON} = 5\text{V}$			1	μA
V_{ONH}	ON High Level Voltage		1.2			V
V_{ONL}	ON Low Level Voltage				0.5	V
Switching ON Resistance						
R_{ON}	Switch ON-State Resistance	$I_{OUT} = -6\text{A}$, $V_{ON} = 5\text{V}$, $V_{BIAS} = 5\text{V}$		4.5	5	m Ω
		$I_{OUT} = -6\text{A}$, $V_{ON} = 5\text{V}$, $V_{BIAS} = 3.3\text{V}$		4.5	5	m Ω
R_{PD}	Output Pull-Down Resistance	$I_{OUT} = 15\text{mA}$, $V_{ON} = 0\text{V}$		220	300	Ω

Switching Characteristics

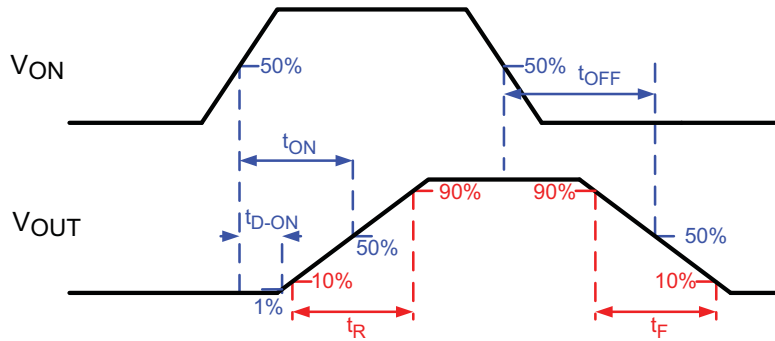

Test conditions: $T_A = 25^\circ\text{C}$, $C_{IN} = 1\mu\text{F}$, $C_L = 0.1\mu\text{F}$ (unless otherwise specified).

Symbol	Parameter	Min.	Typ.	Max.	Units
VIN = 1.05V, VBIAS = VON = 5V, RL = 10Ω					
t_{ON}	Turn-ON Time		800		μs
t_{D-ON}	Turn-ON Delay time	350	500	650	
t_R	Turn-ON Rise Time	350	500	650	
t_{OFF}	Turn-OFF Time		2.8		
t_F	Turn-OFF Fall Time		2.0		
VIN = 1.5V, VBIAS = VON = 5V, RL = 10Ω					
t_{ON}	Turn-ON Time		830		μs
t_{D-ON}	Turn-ON Delay time	336	480	624	
t_R	Turn-ON Rise Time	420	600	780	
t_{OFF}	Turn-OFF Time		2.5		
t_F	Turn-OFF Fall Time		2.0		
VIN = 1.05V, VBIAS = VON = 5V, IOU_T = -6A					
t_{ON}	Turn-ON Time		1140		μs
t_{D-ON}	Turn-ON Delay time		660		
t_R	Turn-ON Rise Time		700		
t_{OFF}	Turn-OFF Time		2.3		
t_F	Turn-OFF Fall Time		0.5		
VIN = 1.5V, VBIAS = VON = 5V, IOU_T = -6A					
t_{ON}	Turn-ON Time		1120		μs
t_{D-ON}	Turn-ON Delay time		630		
t_R	Turn-ON Rise Time		770		
t_{OFF}	Turn-OFF Time		2.0		
t_F	Turn-OFF Fall Time		0.5		

Typical Characteristics

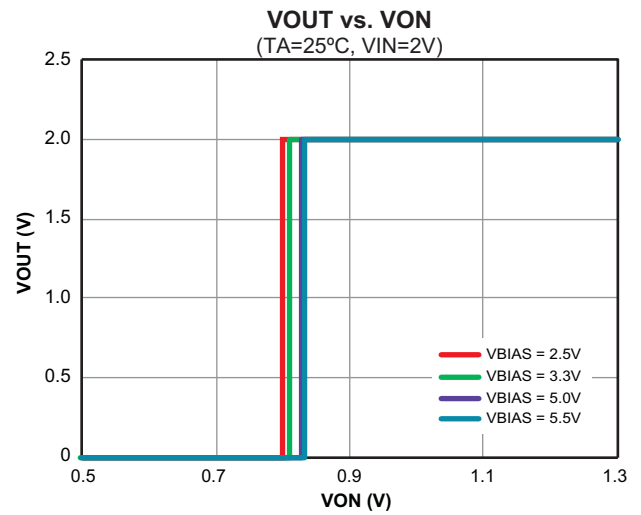
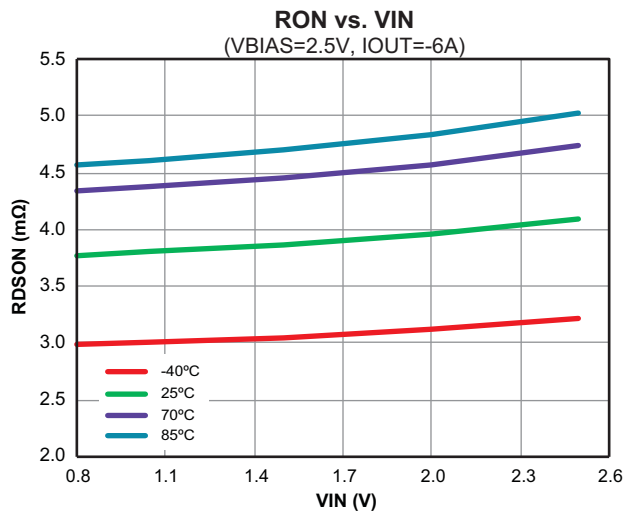
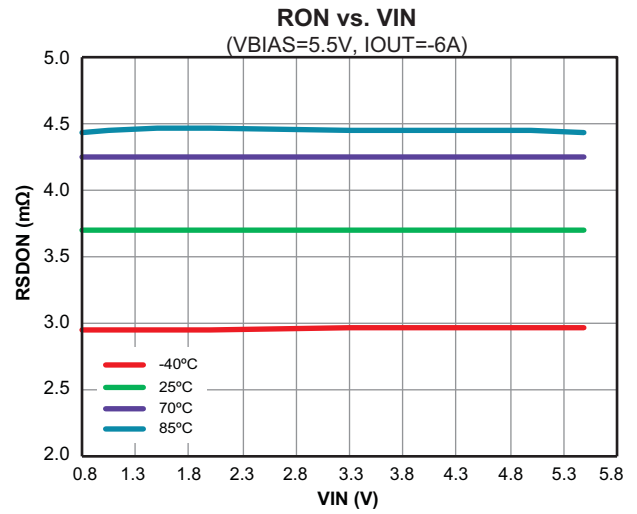
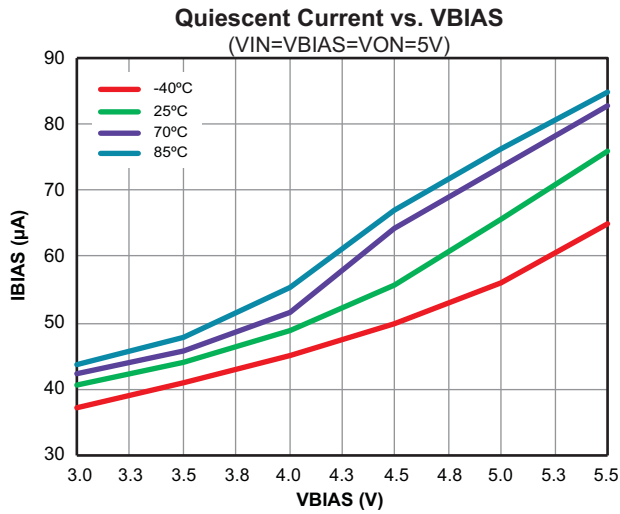

Typical Characteristics (Continued)

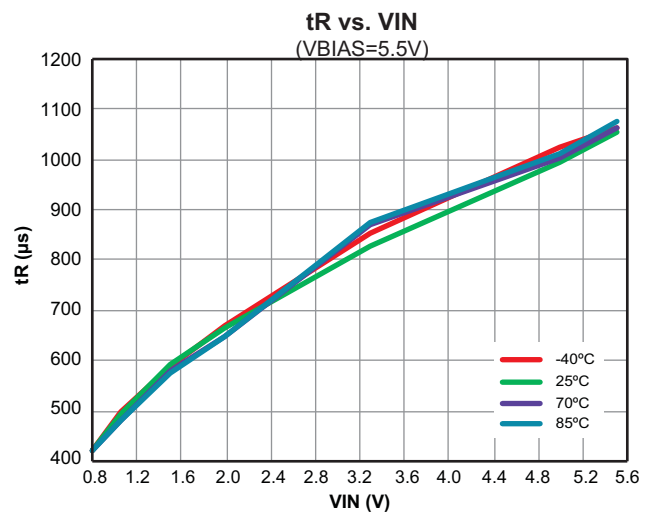
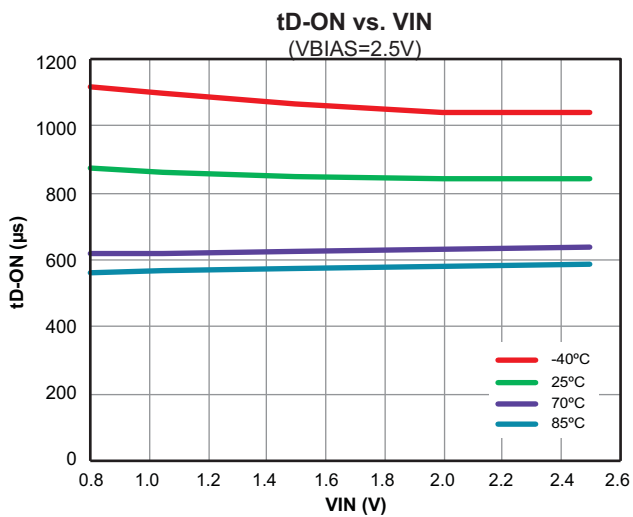
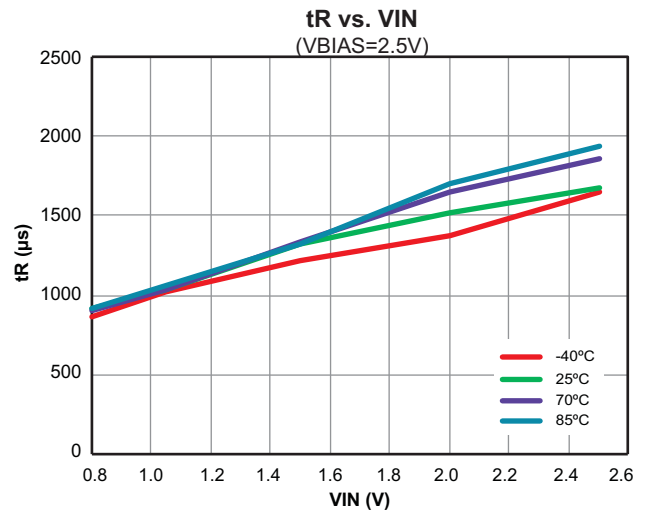
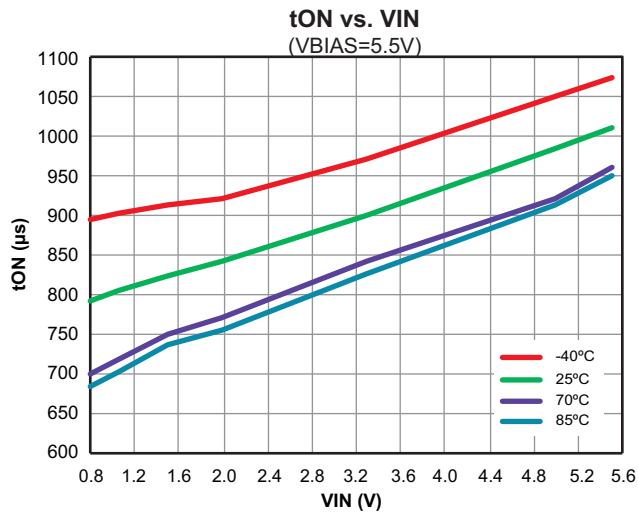
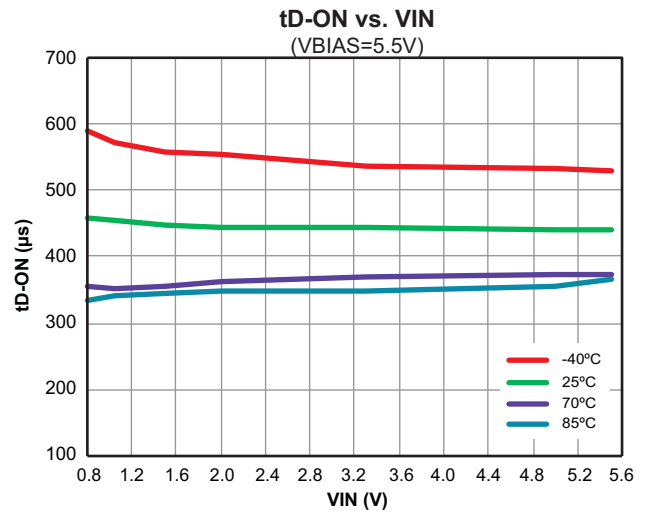
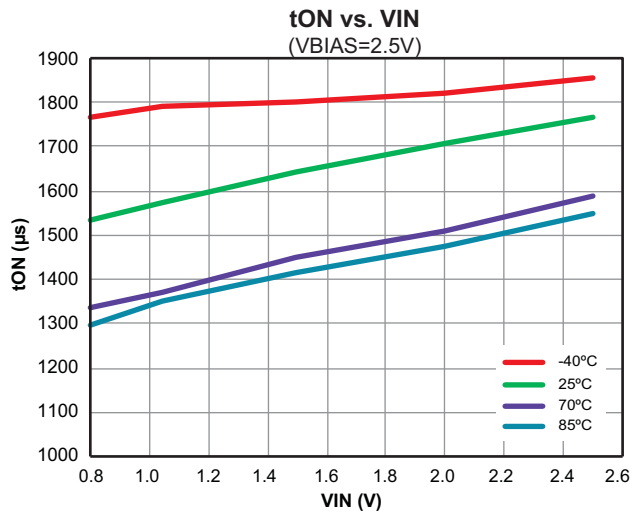

Typical Characteristics (Continued)

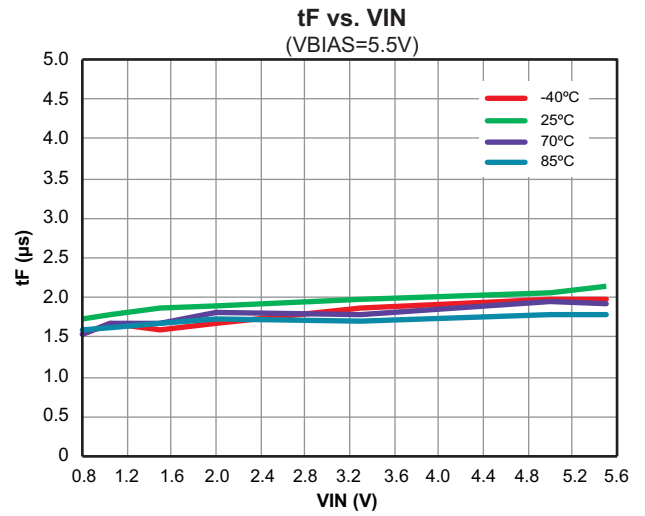
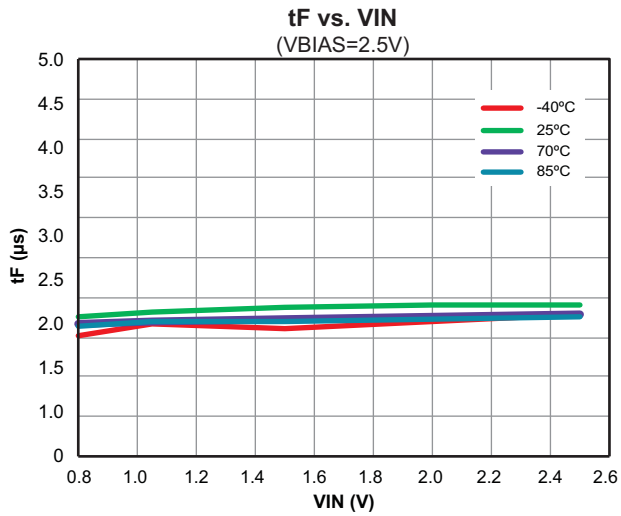
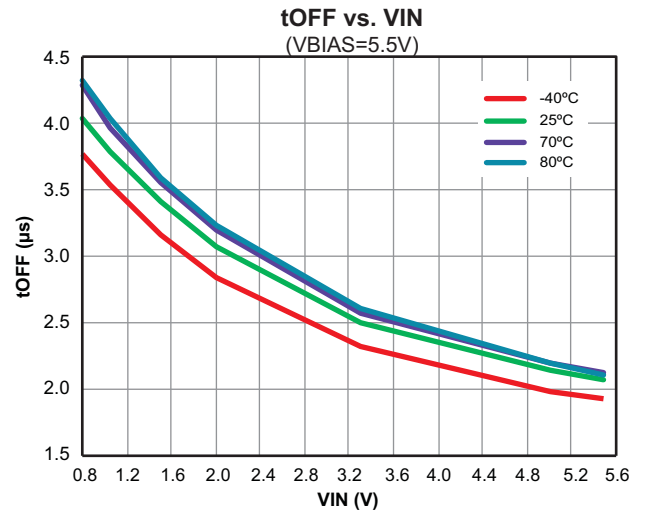
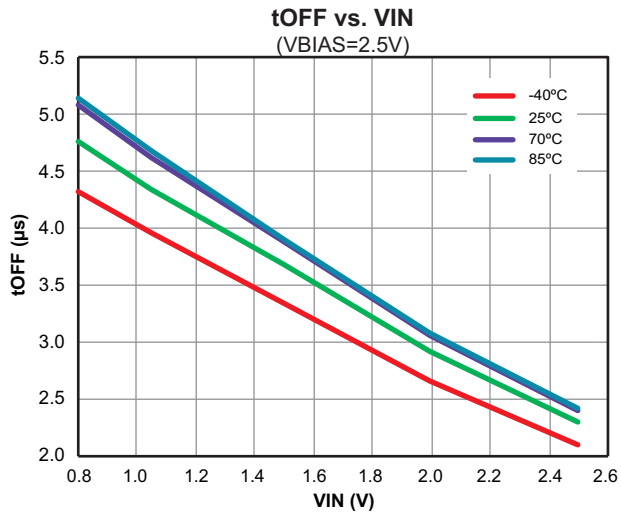

Functional Characteristics

Turn-ON & Turn-ON Rise Times
($V_{INX}=1.05V$, $V_{BIAS}=5V$, $C_{IN}=1\mu F$, $C_L=0.1\mu F$, $R_L=10\Omega$)

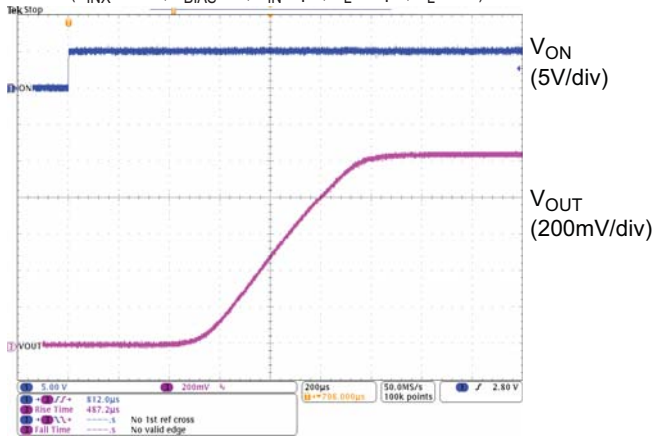

Turn-ON & Turn-ON Rise Times
($V_{INX}=1.5V$, $V_{BIAS}=5V$, $C_{IN}=1\mu F$, $C_L=0.1\mu F$, $R_L=10\Omega$)

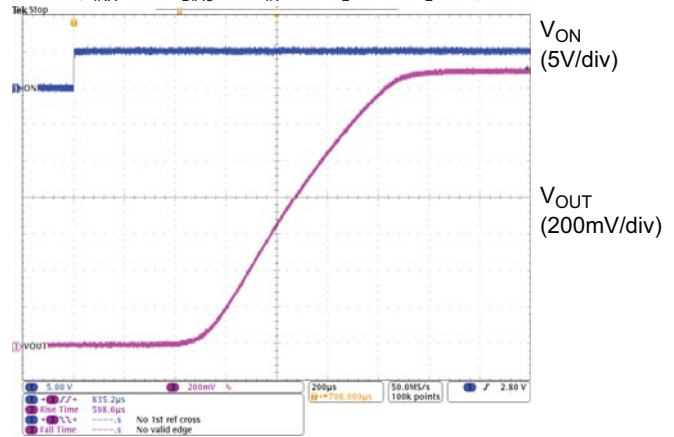

Turn-OFF & Turn-OFF Fall Times
($V_{INX}=1.05V$, $V_{BIAS}=5V$, $C_{IN}=1\mu F$, $C_L=0.1\mu F$, $R_L=10\Omega$)

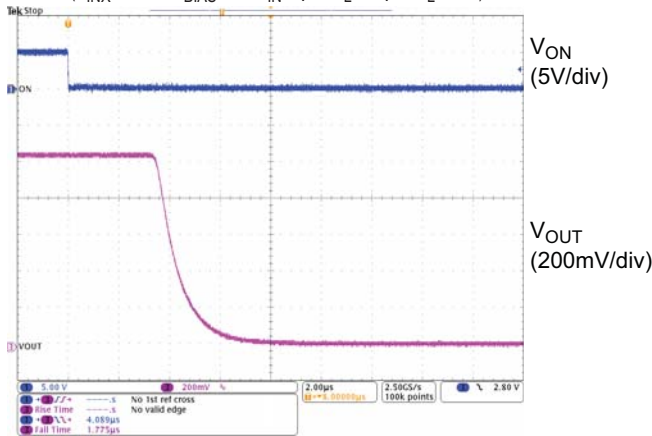

Turn-OFF & Turn-OFF Fall Times
($V_{INX}=1.5V$, $V_{BIAS}=5V$, $C_{IN}=1\mu F$, $C_L=0.1\mu F$, $R_L=10\Omega$)

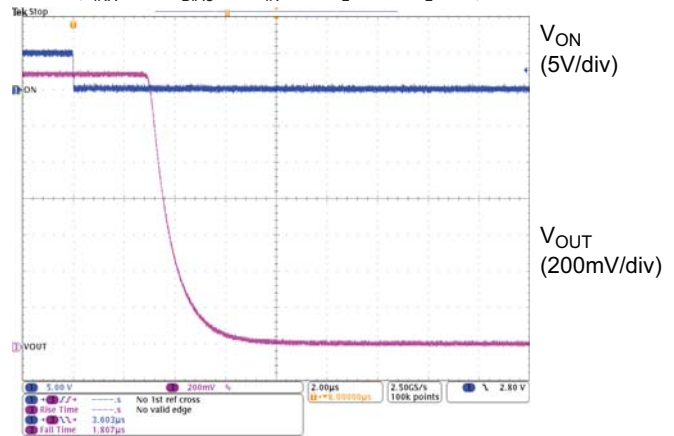

Turn-ON & Turn-OFF at $I_{OUT}=-6A$
($V_{INX}=1.05V$, $V_{BIAS}=5V$, $C_{IN}=1\mu F$, $C_L=0.1\mu F$)

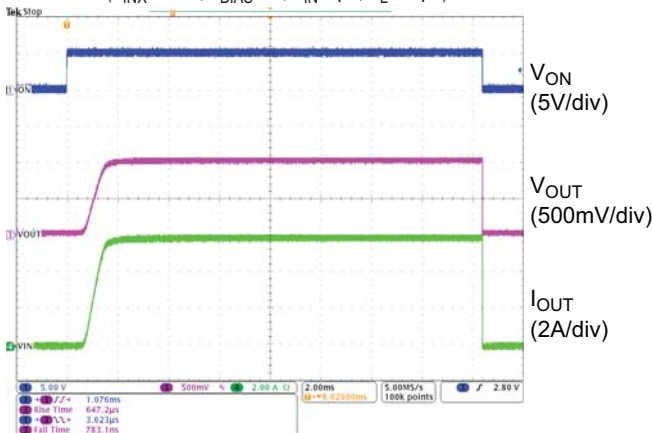

Turn-ON & Turn-OFF at $I_{OUT}=-6A$
($V_{INX}=1.5V$, $V_{BIAS}=5V$, $C_{IN}=1\mu F$, $C_L=0.1\mu F$)

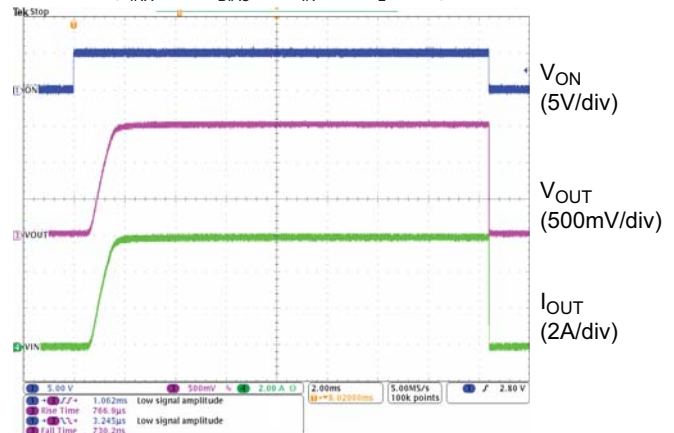

Detailed Description

ON/OFF Control

The AOZ1334DI-02 is enabled when the ON pin is on active high with 1.2V or above voltage. The device is disabled when the ON pin voltage is 0.5V or lower. The EN input is compatible with both TTL and CMOS logic.

VBIAS Voltage Range

For optimal on-resistance of load switch, make sure the voltage is within 2.5V to 5.5V. On-resistance of load switch will be higher if the condition is not satisfied. Resistance curves of a typical sample device at $V_{BIAS} = V_{IN}$ and at different output currents are shown as below.

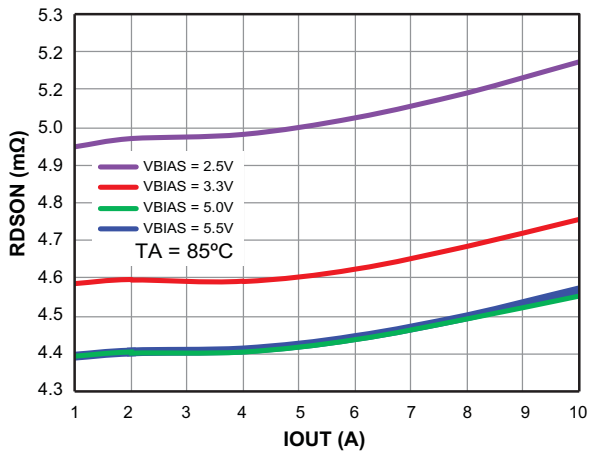
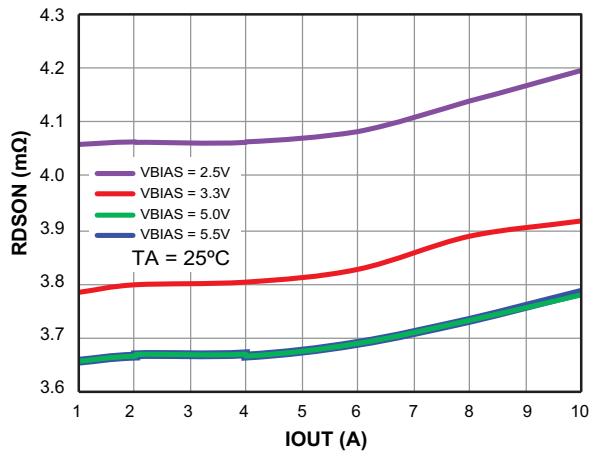

Applications Information

The basic AOZ1334DI-02 application circuit is shown in the first page. Component selection is explained below.

Input Capacitor

A capacitor of 10μF or higher value is recommended to be placed close to the IN pins of AOZ1334DI-02. This capacitor can reduce the voltage drop caused by the in-rush current during the turn-on transient of the load switch. A higher value capacitor can be used to further reduce the voltage drop during high-current application.

Output Capacitor

A capacitor of 10μF or higher value is recommended to be placed between the OUT pins and GND. The capacitance does not affect the turn-on slew rate. However, a larger capacitor makes the initial turn-on transient smoother.

Thermal Considerations

To ensure proper operation, the maximum junction temperature of the AOZ1334DI-02 should not exceed 150°C. Several factors attribute to the junction temperature rise: load current, MOSFET on-resistance, junction-to-ambient thermal resistance, and ambient temperature. The maximum load current can be determined by:

$$I_{LOAD(MAX)} = \sqrt{\frac{T_{J(MAX)} - T_C}{\Theta_{JC} \times R_{DS(ON)}}$$

It is noted that the maximum continuous load current is 10A. Exceeding the maximum continuous load current may cause permanent damage to the device.

Layout Guidelines

Good PCB is important for improving the thermal performance of AOZ1334DI-02. Place the input and output bypass capacitors close to the IN and OUT pins. The input and output PCB traces should be as wide as possible for the given PCB space. Use a ground plane to enhance the power dissipation capability of the device.

Package Dimensions, DFN3x3_8L, EP1_S

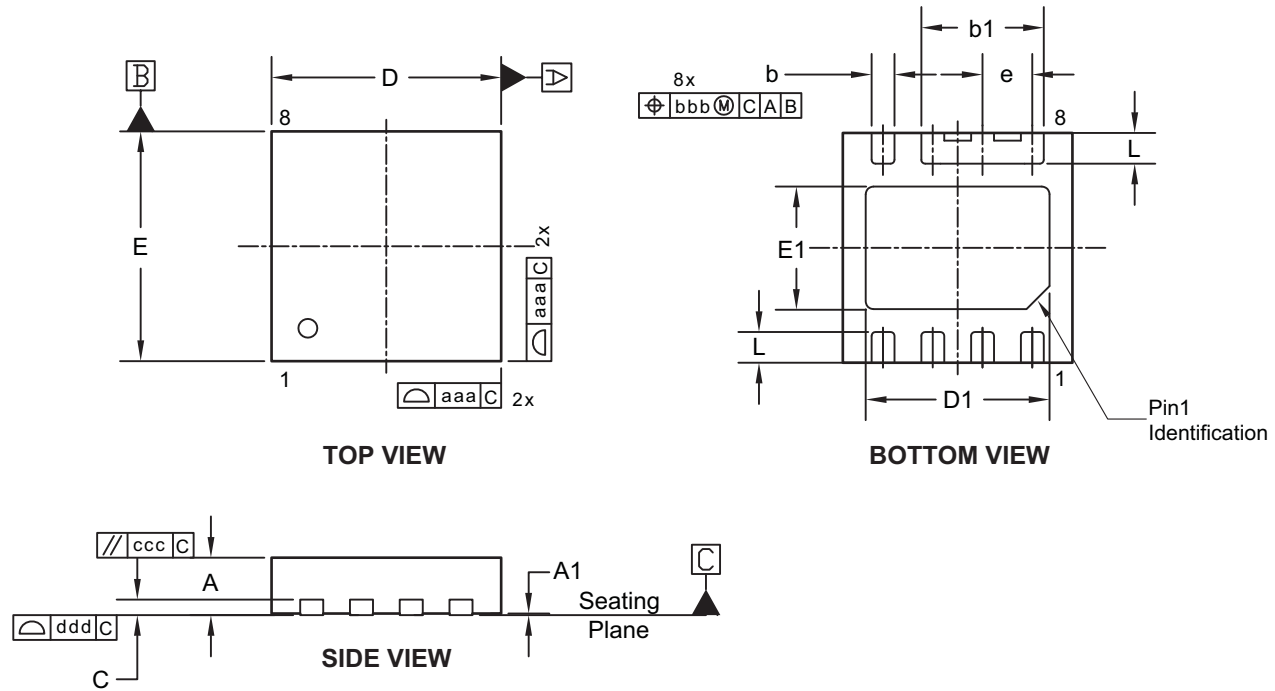

RECOMMENDED LAND PATTERN

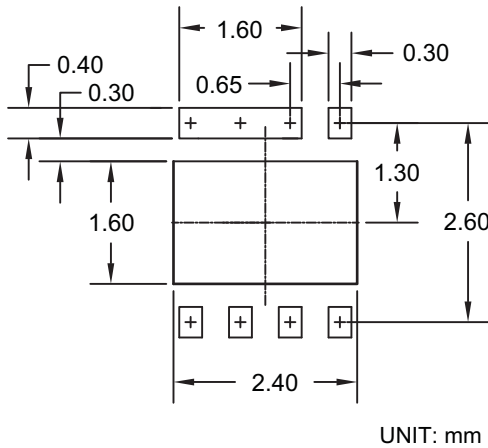

Dimensions in millimeters

Symbols	Min.	Nom.	Max.
A	0.70	0.75	0.80
A1	0.00	0.02	0.05
b1	1.55	1.60	1.65
b	0.25	0.30	0.35
c	---	0.203	---
D	2.90	3.00	3.10
D1	2.35	2.40	2.45
E	2.90	3.00	3.10
E1	1.50	1.60	1.70
e	0.65 BSC		
L	0.35	0.40	0.45
R	0.20		
aaa	0.15		
bbb	0.10		
ccc	0.10		
ddd	0.08		

Dimensions in inches

Symbols	Min.	Nom.	Max.
A	0.028	0.030	0.031
A1	0.000	0.001	0.002
b1	0.061	0.063	0.065
b	0.010	0.012	0.014
c	---	0.008	---
D	0.114	0.118	0.122
D1	0.093	0.094	0.096
E	0.114	0.118	0.122
E1	0.059	0.063	0.067
e	0.026 BSC		
L	0.014	0.016	0.018
R	0.008		
aaa	0.006		
bbb	0.004		
ccc	0.004		
ddd	0.003		

Notes:

1. Dimensions and tolerances conform to ASME Y14.5M-1994.
2. Controlling dimension is millimeter, converted inch dimensions are not necessarily exact.
3. Dimension b applies to metallized terminal and is measured between 0.15mm and 0.30mm from the terminal tip. If the terminal has the optional radius on the other end of the terminal, dimension b should not be measured in that radius area.
4. Coplanarity ddd applies to the terminals and all other bottom surface metallization.

Tape and Reel Dimensions, DFN3x3_8L, EP1_S

Carrier Tape

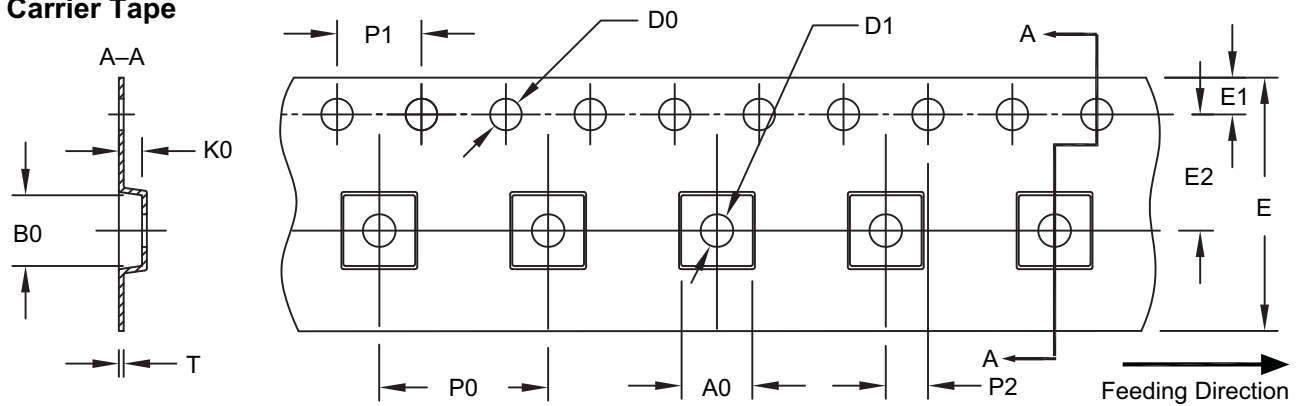

UNIT: mm

Package	A0	B0	K0	D0	D1	E	E1	E2	P0	P1	P2	T
DFN 3x3_EP	3.40 ±0.10	3.35 ±0.10	1.10 ±0.10	1.50 +0.10/-0.0	1.50 +0.10/-0.0	12.00 ±0.30	1.75 ±0.10	5.50 ±0.05	8.00 ±0.10	4.00 ±0.10	2.00 ±0.05	0.30 ±0.05

Reel

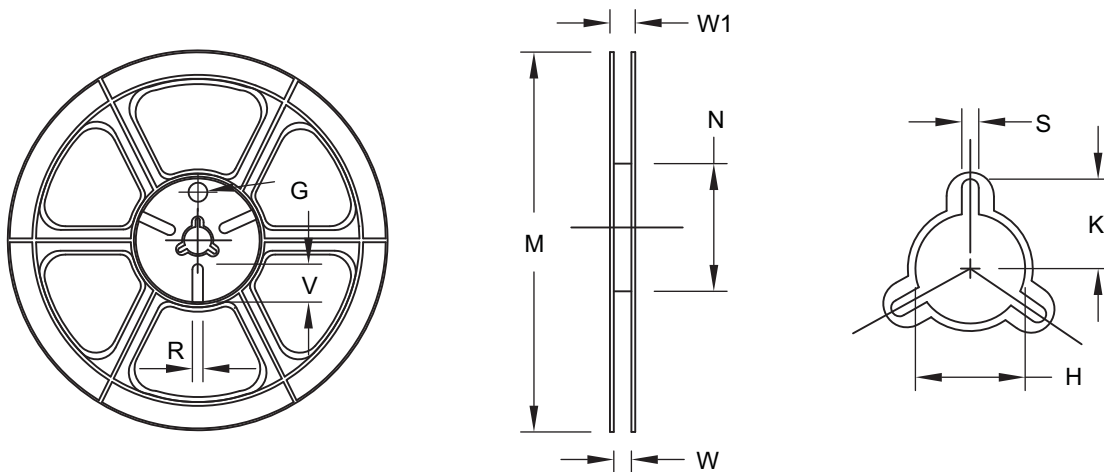

UNIT: mm

Tape Size	Reel Size	M	N	W	W1	H	K	S	G	R	V
12mm	ø330	ø330.00 ±0.50	ø97.00 ±0.10	13.00 ±0.30	17.40 ±1.00	ø13.00 +0.5/-0.2	10.60	2.00 ±0.50	N/A	N/A	N/A

Leader / Trailer & Orientation

Unit Per Reel:
5000pcs

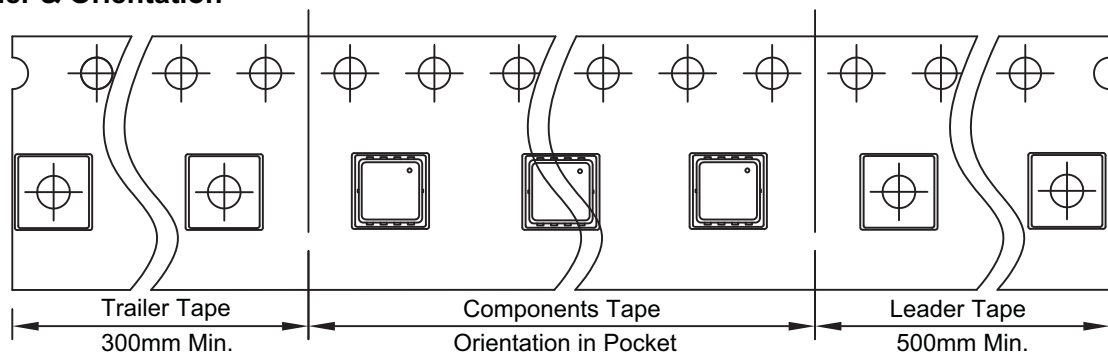

Package Marking

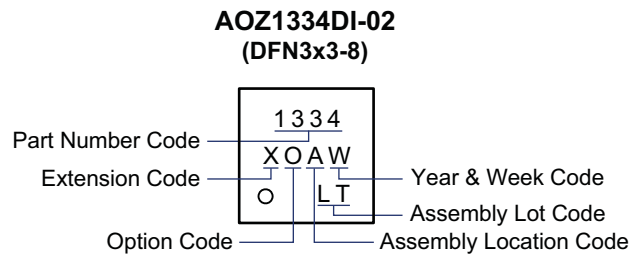

LEGAL DISCLAIMER

Applications or uses as critical components in life support devices or systems are not authorized. AOS does not assume any liability arising out of such applications or uses of its products. AOS reserves the right to make changes to product specifications without notice. It is the responsibility of the customer to evaluate suitability of the product for their intended application. Customer shall comply with applicable legal requirements, including all applicable export control rules, regulations and limitations.

AOS' products are provided subject to AOS' terms and conditions of sale which are set forth at:

http://www.aosmd.com/terms_and_conditions_of_sale

LIFE SUPPORT POLICY

ALPHA AND OMEGA SEMICONDUCTOR PRODUCTS ARE NOT AUTHORIZED FOR USE AS CRITICAL COMPONENTS IN LIFE SUPPORT DEVICES OR SYSTEMS.

As used herein:

1. Life support devices or systems are devices or systems which, (a) are intended for surgical implant into the body or (b) support or sustain life, and (c) whose failure to perform when properly used in accordance with instructions for use provided in the labeling, can be reasonably expected to result in a significant injury of the user.
2. A critical component in any component of a life support, device, or system whose failure to perform can be reasonably expected to cause the failure of the life support device or system, or to affect its safety or effectiveness.

Looking for pricing, stock, or lifecycle information?

Click below to explore more details on WIN SOURCE:

- ⊖ [View AOZ1334DI-02 on WIN SOURCE](#)
- ⊖ [Alpha & Omega Semiconductor Inc. Information](#)

Optimize Your Supply Chain with WIN SOURCE Solutions

- ✓ Global Sourcing Solution
- ✓ Obsolete Management
- ✓ Cost Control Management
- ✓ Shortage Management
- ✓ Alternative Solution
- ✓ Excess Inventory Management