



**THE DATASHEET OF  
AM4961GSTR-G1**



## Description

The AM4961 is a full wave driver IC with PWM control function. It is used for single phase motor and is capable of speed control by changing output duty cycle.

The AM4961 is available in SSOP-16 and HTSSOP-14 packages.

## Features

- Built-In Hall Bias Circuit
- Built-In PWM Speed Control Circuit
- Built-In Minimal Speed Setup Circuit
- Rotation Speed Indication (FG)
- Rotation or Lock State Indication (RD)
- Built-In Thermal Shutdown Circuit
- Lock Protection
- Output Current Limit
- **Totally Lead-Free & Fully RoHS Compliant (Notes 1 & 2)**
- **Halogen and Antimony Free. "Green" Device (Note 3)**

## Pin Assignments

(Top View)

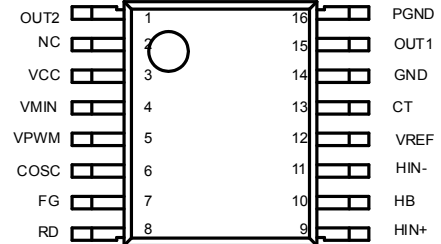

**SSOP-16**

(Top View)

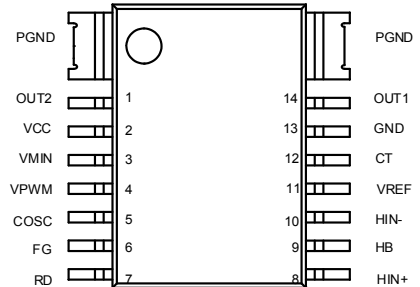

**HTSSOP-14**

## Applications

- CPU Cooler Fan in PC
- Brushless DC Motor Driver

- Notes:
1. No purposely added lead. Fully EU Directive 2002/95/EC (RoHS), 2011/65/EU (RoHS 2) & 2015/863/EU (RoHS 3) compliant.
  2. See <https://www.diodes.com/quality/lead-free/> for more information about Diodes Incorporated's definitions of Halogen- and Antimony-free, "Green" and Lead-free.
  3. Halogen- and Antimony-free "Green" products are defined as those which contain <900ppm bromine, <900ppm chlorine (<1500ppm total Br + Cl) and <1000ppm antimony compounds.

**Typical Applications Circuit** (Note 4)

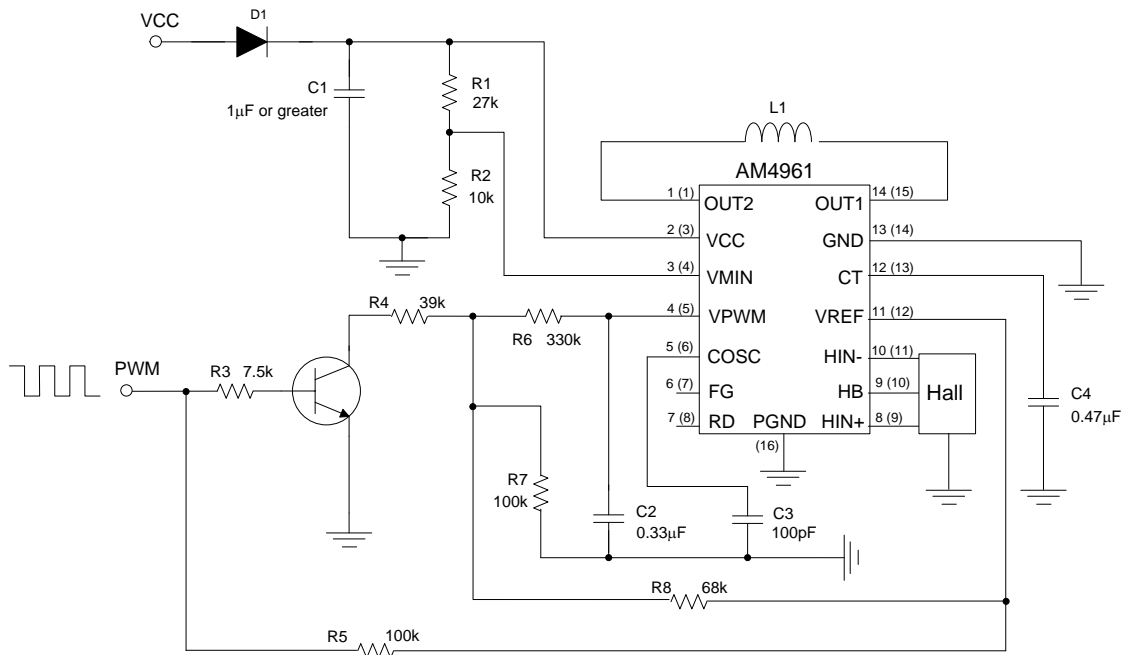

Note 4:

\*1. Ground Line Layout

PGND is connected to motor supply stage and GND is connected to control stage. All ground lines from control stage are connected to GND.

\*2. Stability of Power Supply

C1 is employed to stabilize VCC. Its capacitance is no less than 1µF.

\*3. Hall Input

To avoid noise, the shortest line is recommended to connect with Hall stage which has about 20mV hysteresis. Thus, the ideal Hall input is 50mV or over.

\*4. COSC Capacitor

When CCP is 100pF, the COSC frequency will be 25kHz.

\*5. FG Output

FG output terminal is open collector output which varies with phase change.

\*6. RD Output

RD output terminal is open collector output. It is low at rotation mode and high when stopped.

\*7. HB Pin

This pin is available to output a 1.25V Hall bias voltage.

\*8. VMIN Pin

If this pin is disused, connect it directly with VPWM, the minimum duty cycle will be 10%.

## Pin Descriptions

Pin Number		Pin Name	Function
HTSSOP-14	SSOP-16		
1	1	OUT2	Driver output 2
–	2	NC	No connection
2	3	VCC	Power supply
3	4	VMIN	Minimum duty setting
4	5	VPWM	Adjustable Input
5	6	COSC	Oscillator capacitor
6	7	FG	Rotation speed indicator
7	8	RD	Rotation/lock state indicator
8	9	HIN+	Hall sensor input +
9	10	HB	Hall sensor bias regulator
10	11	HIN-	Hall sensor input
11	12	VREF	Reference voltage regulator
12	13	CT	Lock and rotation setting capacitor terminal
13	14	GND	Ground for control circuit
14	15	OUT1	Driver output 1
–	16	PGND	Power ground

**Functional Block Diagram**

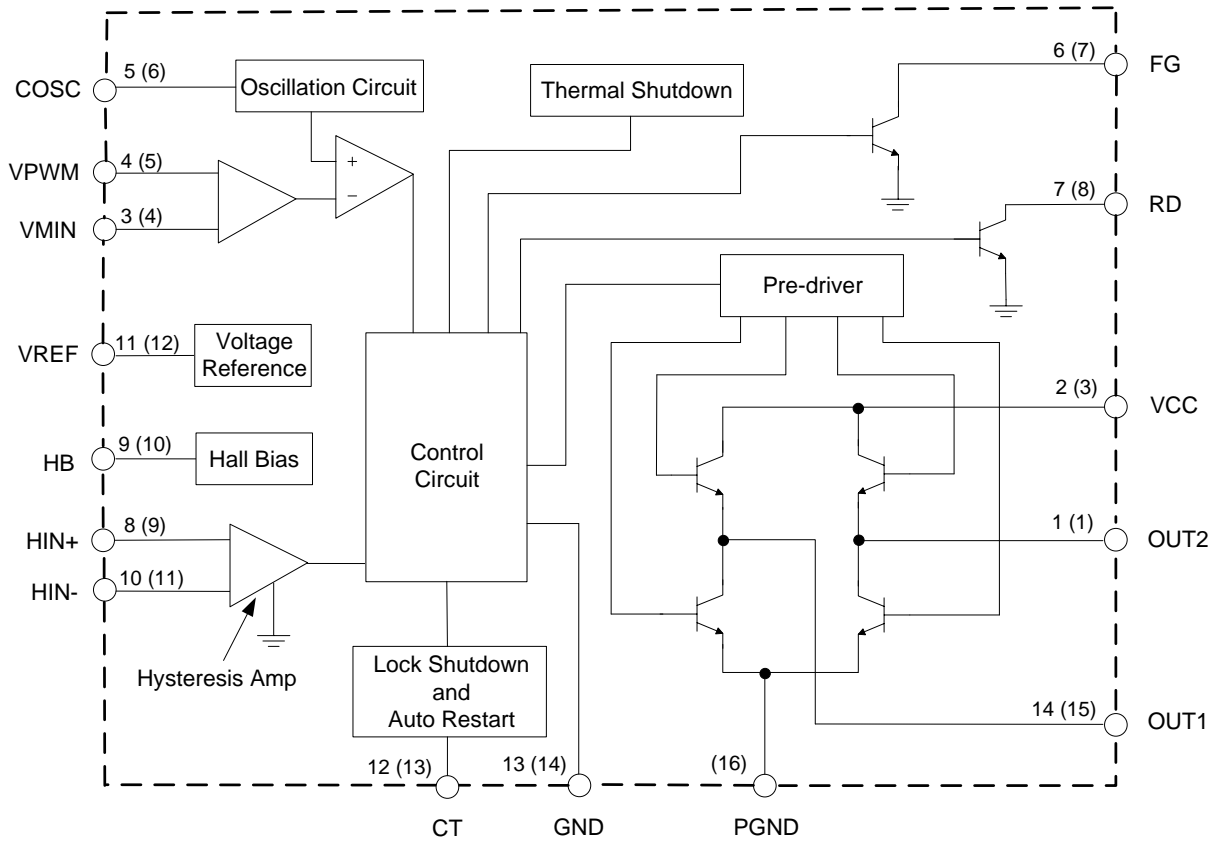

A (B)  
A for 14-pin    B for 16-pin

## Absolute Maximum Ratings (Note 5)

Symbol	Parameter	Value		Unit
V <sub>CC</sub>	Supply Voltage	18		V
I <sub>OUT</sub>	Output Current	1.0		A
V <sub>OUT</sub>	Output Voltage	18		V
I <sub>HB</sub>	HB Output Current	10		mA
V <sub>PWM</sub>	VPWM Input Voltage	6		V
V <sub>RD</sub>	RD Output Voltage	18		V
V <sub>FG</sub>	FG Output Voltage	18		V
I <sub>RD</sub>	RD Output Current	10		mA
I <sub>FG</sub>	FG Output Current	10		mA
P <sub>D</sub>	Power Dissipation (Note 6)	SSOP-16	0.8	W
		HTSSOP-14	1.1	W
T <sub>STG</sub>	Storage Temperature Range	-55 to +150		°C
ESD	ESD (Human Body Model)	2000		V
ESD	ESD (Machine Model)	250		V

- Notes:
- Stresses greater than those listed under "Absolute Maximum Ratings" can cause permanent damage to the device. These are stress ratings only, and functional operation of the device at these or any other conditions beyond those indicated under "Recommended Operating Conditions" is not implied. Exposure to "Absolute Maximum Ratings" for extended periods can affect device reliability.
  - T<sub>A</sub> = +25°C, no external heatsink.

## Recommended Operating Conditions

Symbol	Parameter	Min	Typ	Max	Unit
V <sub>CC</sub>	Supply Voltage	3.5	12	16	V
V <sub>IN+</sub>	Hall Input Voltage + (Note 7)	0.2	–	3	V
V <sub>IN-</sub>	Hall Input Voltage - (Note 7)	0.2	–	3	V
T <sub>A</sub>	Ambient Temperature	-30	–	+90	°C

- Note:
- Hall input voltage range includes the amplitude of signal.

**Electrical Characteristics** ( $V_{CC}=12V$ ,  $T_A=+25^{\circ}C$ , unless otherwise specified.)

Symbol	Parameter	Conditions	Min	Typ	Max	Unit
$I_{Q1}$	Quiescent Current	Lock Off	10.2	15	18.76	mA
$I_{Q2}$		Lock On	5.38	8	10.55	
$V_{REF}$	VREF Voltage	$I_{REF}=5mA$	5.8	6	6.2	V
$V_{SATH}$	Output Saturation Voltage at High Side	$I_{SOURCE}=200mA$	–	1.0	1.17	V
$V_{SATL}$	Output Saturation Voltage at Low Side	$I_{SINK}=200mA$	–	0.2	0.3	V
$f_{OSC}$	COSC Frequency	$C_{OSC}=100pF$	18	25	32	kHz
$V_{OSCH}$	COSC High Level Voltage	–	3.45	3.6	3.75	V
$V_{OSCL}$	COSC Low Level Voltage	–	1.83	1.95	2.07	V
$V_{HYS}$	Hall Input Hysteresis	–	–	$\pm 10$	$\pm 20$	mV
$V_{HB}$	Hall Bias Voltage	$I_{HB}=5mA$	1.1	1.25	1.4	V
$V_{CTH}$	CT High Level Voltage	–	3.55	3.7	3.88	V
$V_{CTL}$	CT Low Level Voltage	–	1.55	1.7	1.85	V
$I_{CHG}$	CT Charge Current	–	1.5	2	2.85	$\mu A$
$I_{DHG}$	CT Discharge Current	–	0.14	0.2	0.285	$\mu A$
$R_{CD}$	CT Charge and Discharge Ratio	$I_{CHG}/I_{DHG}$	8.5	10	14.5	–
$V_{FGL}$	FG Output Low Level Voltage	$I_{FG}=5mA$	–	0.2	0.3	V
$I_{LFG}$	FG Leakage Current	$V_{FG}=12V$	–	–	30	$\mu A$
$V_{RD L}$	RD Output Low Level Voltage	$I_{RD}=5mA$	–	0.2	0.3	V
$I_{LRD}$	RD Leakage Current	$V_{RD}=12V$	–	–	30	$\mu A$

**Performance Characteristics**

**Quiescent Current vs. Ambient Temperature**

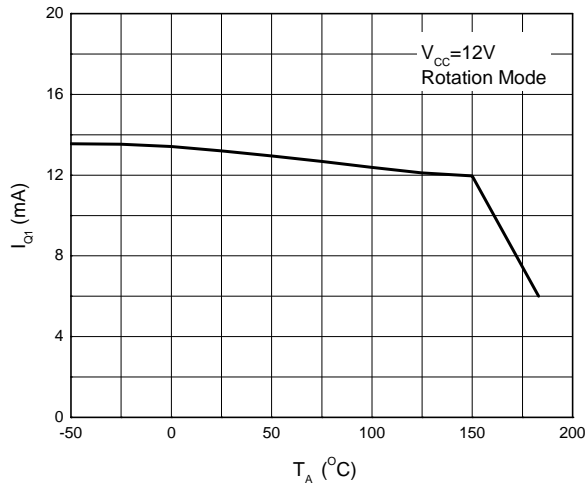

**Quiescent Current vs. Supply Temperature**

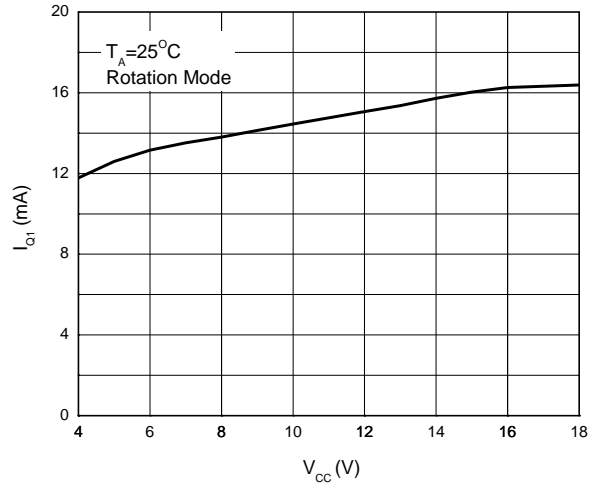

**Output Saturation Voltage (High) vs. Output Current**

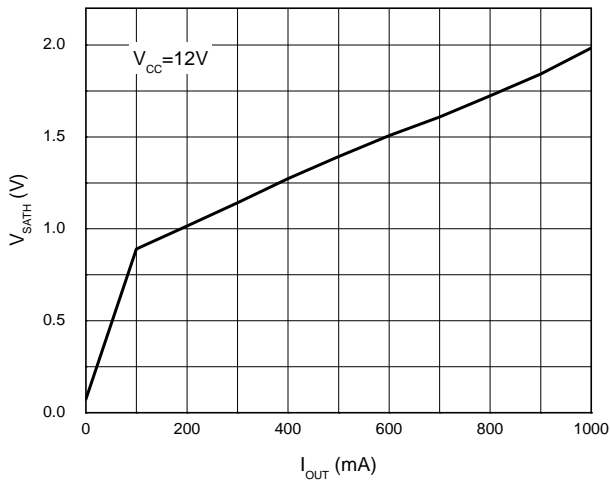

**Output Saturation Voltage (Low) vs. Output Current**

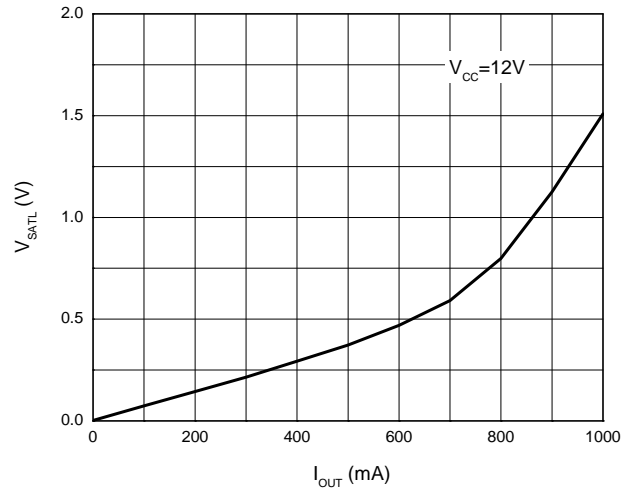

**Power Dissipation vs. Ambient Temperature**

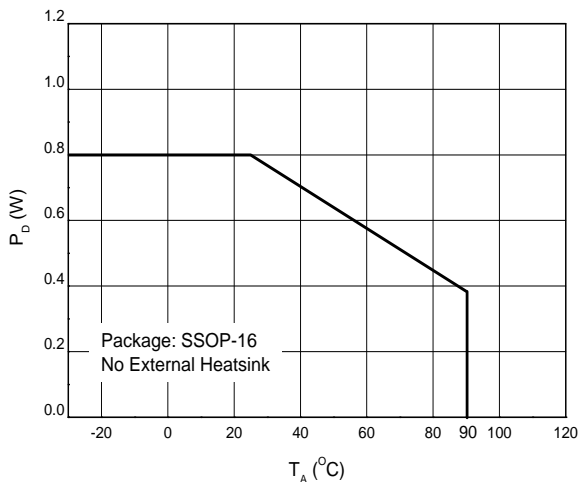

**Power Dissipation vs. Ambient Temperature**

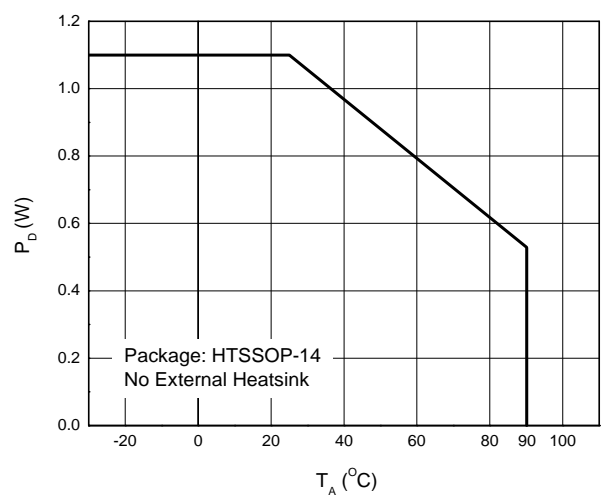

**Ordering Information**

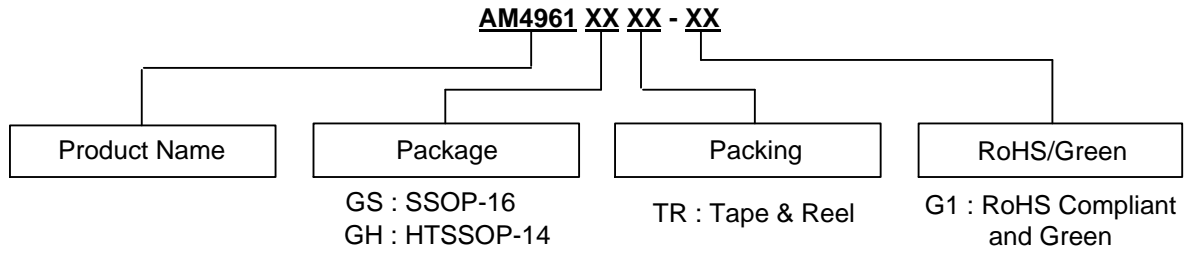

Package	Temperature Range	Part Number	Marking ID	13" Tape and Reel
				Quantity
SSOP-16	-30 to +90°C	AM4961GSTR-G1	AM4961GS-G1	3000/Tape & Reel
HTSSOP-14	-30 to +90°C	AM4961GHTR-G1	AM4961GH-G1	3000/Tape & Reel

**Operating Diagram** (Note 8)

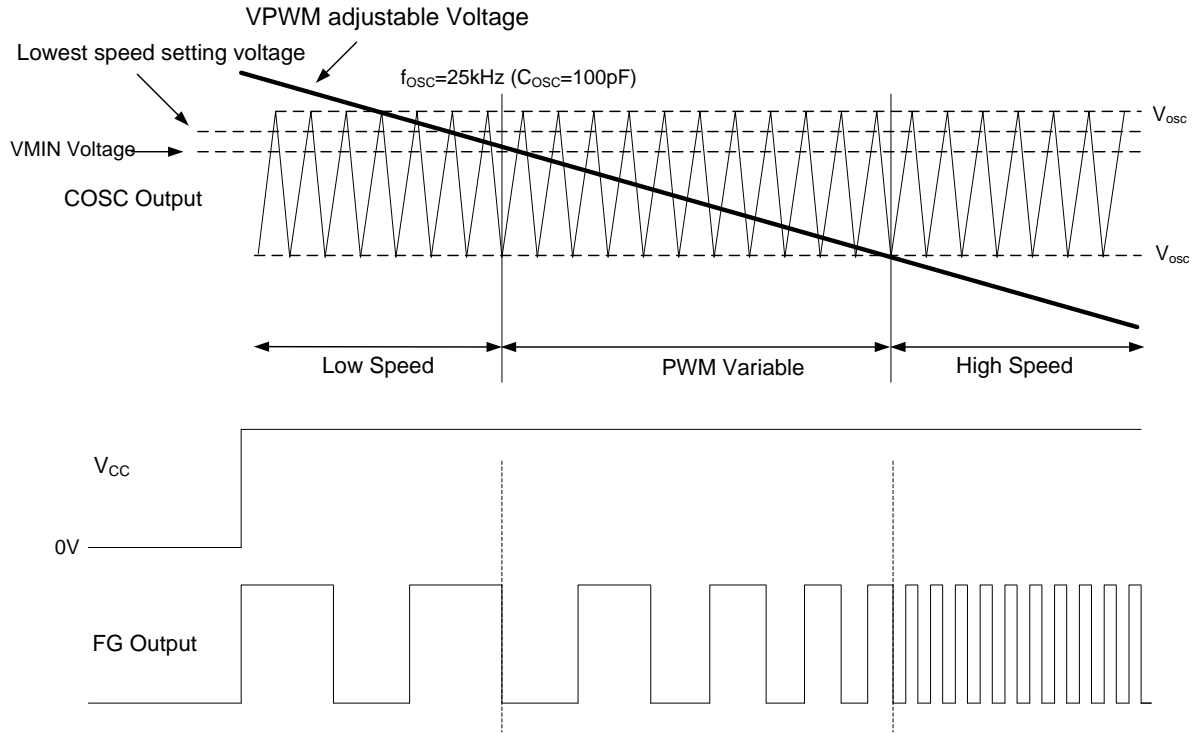

Note 8:

1. Low Speed Setting Mode

When VPWM voltage is higher than VMIN pin voltage, motor speed is settable by VMIN pin voltage. The minimum drive duty cycle is settable by comparing COSC oscillating voltage and VMIN pin voltage.

VPWM voltage is decided by variation of PWM duty.

2. Variable Speed Setting Mode

When VPWM voltage is lower than VMIN pin voltage, PWM control system works by comparing VPWM voltage and COSC voltage. If VPWM voltage is higher, the ON duty cycle of the upper side transistors will be minimized and motor speed becomes lower. Vice versa.

3. Full Speed Rotation Mode

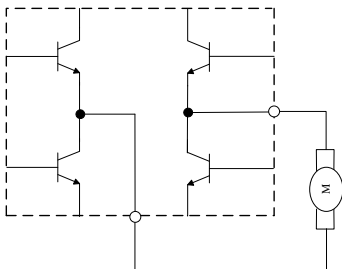

At a certain PWN duty, when VPWM voltage is lower than the low side of COSC output voltage, the motor will run at full speed.

**Package Outline Dimensions** (All dimensions in mm(inch).)

Please see <http://www.diodes.com/package-outlines.html> for the latest version.

(1) Package Type: SSOP-16

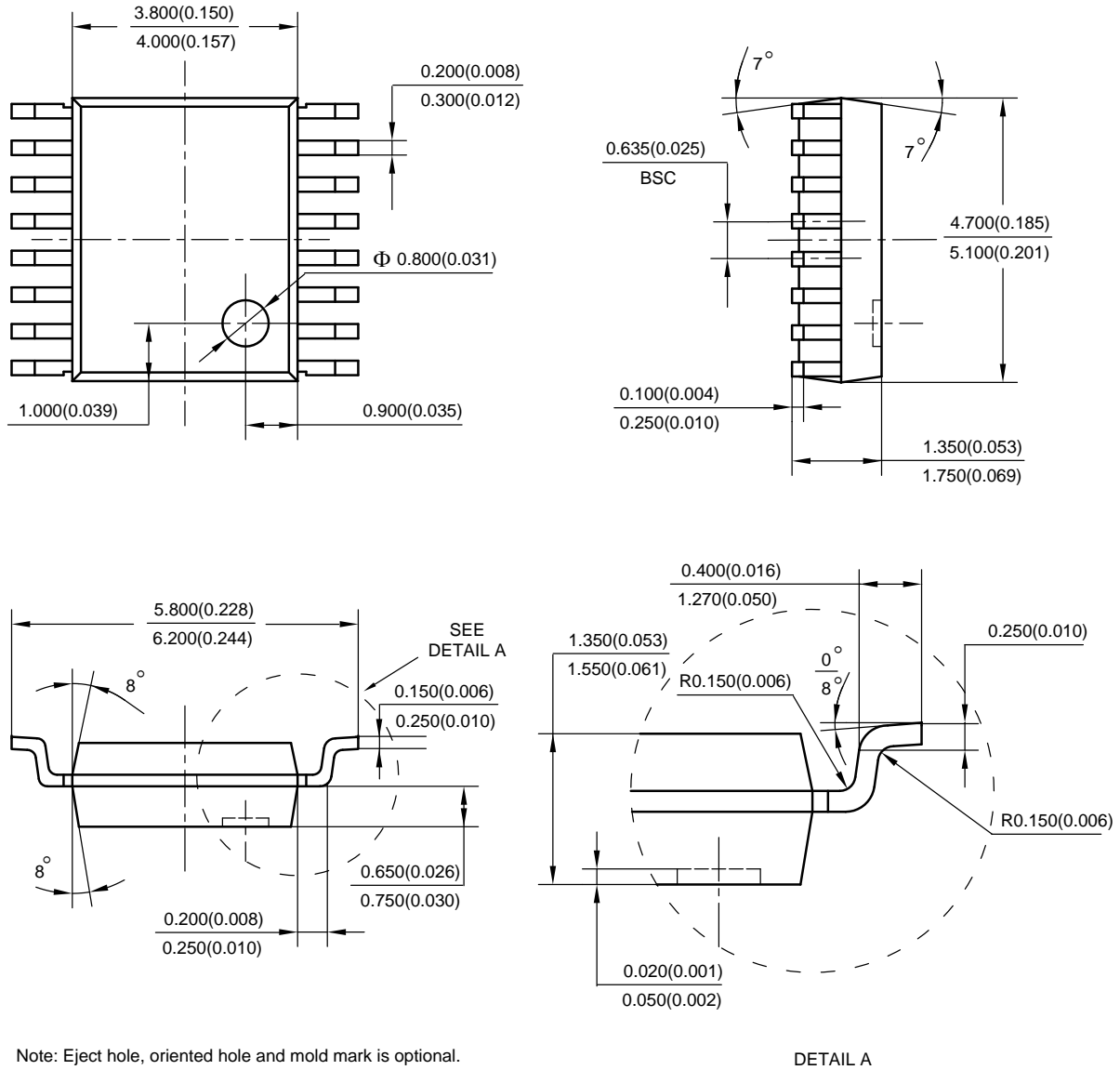

**Package Outline Dimensions** (continued. All dimensions in mm(inch).)

Please see <http://www.diodes.com/package-outlines.html> for the latest version.

(2) Package Type: HTSSOP-14

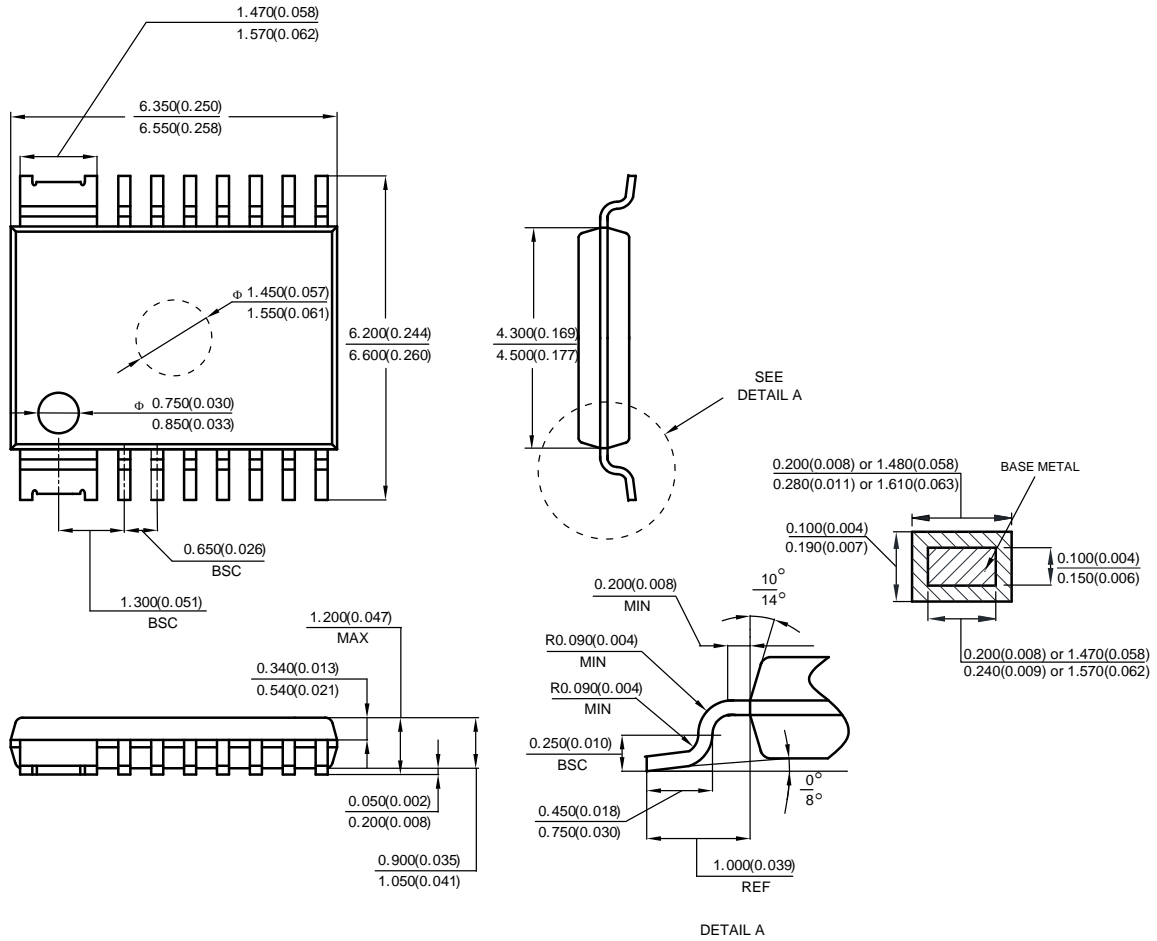

Note: Eject hole, oriented hole and mold mark is optional.

**Suggested Pad Layout**

Please see <http://www.diodes.com/package-outlines.html> for the latest version.

(1) Package Type: SSOP-16

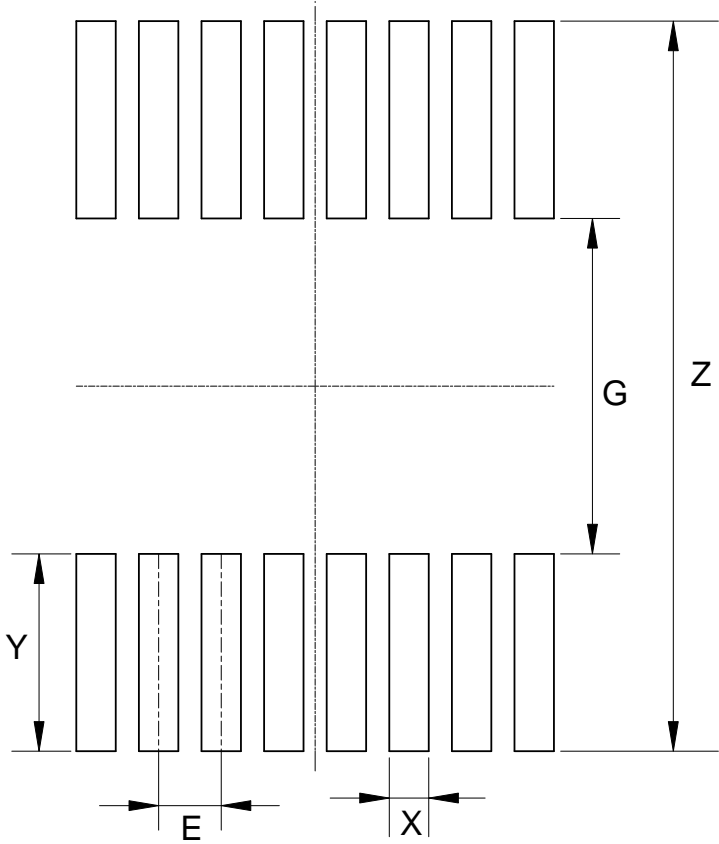

Dimensions	Z (mm)/(inch)	G (mm)/(inch)	X (mm)/(inch)	Y (mm)/(inch)	E (mm)/(inch)
Value	7.400/0.291	3.400/0.134	0.400/0.016	2.000/0.079	0.635/0.025

**Suggested Pad Layout** (continued)

Please see <http://www.diodes.com/package-outlines.html> for the latest version.

(2) Package Type: HTSSOP-14

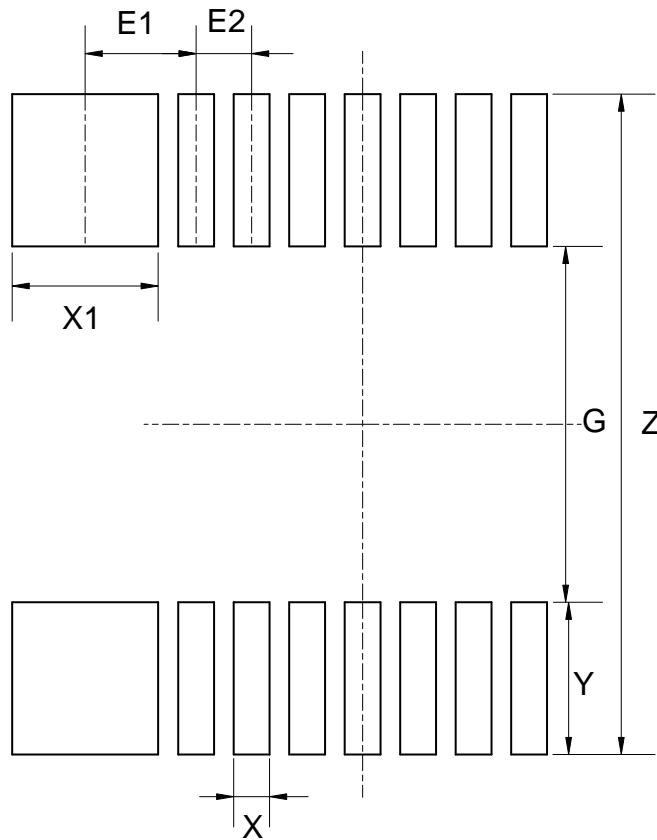

Dimensions	Z (mm)/(inch)	G (mm)/(inch)	X (mm)/(inch)	X1 (mm)/(inch)
Value	7.720/0.304	4.160/0.164	0.420/0.017	1.710/0.067
Dimensions	Y (mm)/(inch)	E1 (mm)/(inch)	E2 (mm)/(inch)	—
Value	1.780/0.070	1.300/0.051	0.650/0.026	—

### IMPORTANT NOTICE

DIODES INCORPORATED MAKES NO WARRANTY OF ANY KIND, EXPRESS OR IMPLIED, WITH REGARDS TO THIS DOCUMENT, INCLUDING, BUT NOT LIMITED TO, THE IMPLIED WARRANTIES OF MERCHANTABILITY AND FITNESS FOR A PARTICULAR PURPOSE (AND THEIR EQUIVALENTS UNDER THE LAWS OF ANY JURISDICTION).

Diodes Incorporated and its subsidiaries reserve the right to make modifications, enhancements, improvements, corrections or other changes without further notice to this document and any product described herein. Diodes Incorporated does not assume any liability arising out of the application or use of this document or any product described herein; neither does Diodes Incorporated convey any license under its patent or trademark rights, nor the rights of others. Any Customer or user of this document or products described herein in such applications shall assume all risks of such use and will agree to hold Diodes Incorporated and all the companies whose products are represented on Diodes Incorporated website, harmless against all damages.

Diodes Incorporated does not warrant or accept any liability whatsoever in respect of any products purchased through unauthorized sales channel. Should Customers purchase or use Diodes Incorporated products for any unintended or unauthorized application, Customers shall indemnify and hold Diodes Incorporated and its representatives harmless against all claims, damages, expenses, and attorney fees arising out of, directly or indirectly, any claim of personal injury or death associated with such unintended or unauthorized application.

Products described herein may be covered by one or more United States, international or foreign patents pending. Product names and markings noted herein may also be covered by one or more United States, international or foreign trademarks.

This document is written in English but may be translated into multiple languages for reference. Only the English version of this document is the final and determinative format released by Diodes Incorporated.

### LIFE SUPPORT

Diodes Incorporated products are specifically not authorized for use as critical components in life support devices or systems without the express written approval of the Chief Executive Officer of Diodes Incorporated. As used herein:

A. Life support devices or systems are devices or systems which:

1. are intended to implant into the body, or
2. support or sustain life and whose failure to perform when properly used in accordance with instructions for use provided in the labeling can be reasonably expected to result in significant injury to the user.

B. A critical component is any component in a life support device or system whose failure to perform can be reasonably expected to cause the failure of the life support device or to affect its safety or effectiveness.

Customers represent that they have all necessary expertise in the safety and regulatory ramifications of their life support devices or systems, and acknowledge and agree that they are solely responsible for all legal, regulatory and safety-related requirements concerning their products and any use of Diodes Incorporated products in such safety-critical, life support devices or systems, notwithstanding any devices- or systems-related information or support that may be provided by Diodes Incorporated. Further, Customers must fully indemnify Diodes Incorporated and its representatives against any damages arising out of the use of Diodes Incorporated products in such safety-critical, life support devices or systems.

Copyright © 2019, Diodes Incorporated

[www.diodes.com](http://www.diodes.com)

## Looking for pricing, stock, or lifecycle information?

Click below to explore more details on WIN SOURCE:

-  [View AM4961GSTR-G1 on WIN SOURCE](#)
-  [Diodes Incorporated Information](#)

## Optimize Your Supply Chain with WIN SOURCE Solutions

-  Global Sourcing Solution
-  Obsolete Management
-  Cost Control Management
-  Shortage Management
-  Alternative Solution
-  Excess Inventory Management