



**THE DATASHEET OF  
AL9901S16-13**



## Description

The AL9901, high-voltage PWM LED driver provides an efficient solution for offline, high-brightness LED lamps for rectified line voltages ranging from 85V<sub>AC</sub> up to 305V<sub>AC</sub>. The AL9901 has an internal MOSFET that allows switching frequencies up to 300kHz, with the switching frequency determined by an external single resistor. The AL9901 topology creates a constant current through the LEDs providing constant light output. The output current is programmed by one external resistor.

The LED brightness can be varied by both Linear and PWM dimming, using the AL9901's LD and PWM pins respectively. The PWM input operates with a duty ratio of 0-100% and a frequency of up to several kHz.

The AL9901 is available in the thermally enhanced U-DFN6040-12 and SO-16 packages. The SO-16 is compliant to high voltage spacing rules for 230VAC mains applications.

## Features

- >90% Efficiency
- Universal Rectified 85 to 305V<sub>AC</sub> Input Range
- Internal MOSFET Up to 650V, 2A
- High Switching Frequency Up to 300kHz
- Internal Voltage Regulator Removes Start-Up Resistor
- 7.5V Regulated Output
- Tighter Current Sense Tolerance Better Than 5%
- LED Brightness Control with Linear and PWM Dimming
- Internal Over-Temperature Protection (OTP)
- U-DFN6040-12 and SO-16 Packages
- **Totally Lead-Free & Fully RoHS Compliant (Notes 1 & 2)**
- **Halogen and Antimony Free. "Green" Device (Note 3)**

Notes: 1. No purposely added lead. Fully EU Directive 2002/95/EC (RoHS) & 2011/65/EU (RoHS 2) compliant.  
2. See <http://www.diodes.com> for more information about Diodes Incorporated's definitions of Halogen- and Antimony-free, "Green" and Lead-free.  
3. Halogen- and Antimony-free "Green" products are defined as those which contain <900ppm bromine, <900ppm chlorine (<1500ppm total Br + Cl) and <1000ppm antimony compounds.

## Pin Assignments

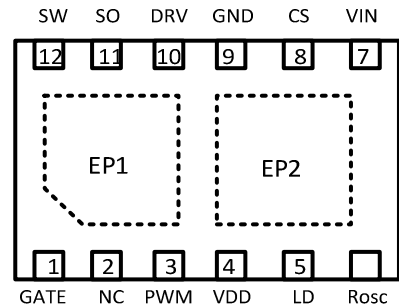

**U-DFN6040-12**

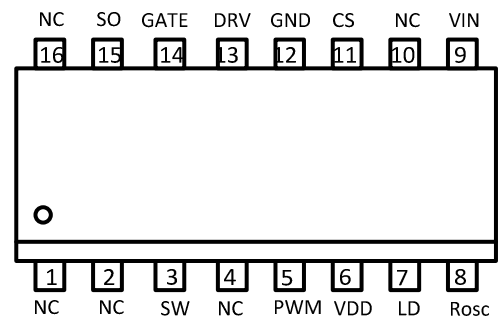

**SO-16**

## Applications

- LED Offline Lamps
- High Voltage DC-DC LED Driver
- Signage and Decorative LED Lighting
- Back Lighting of Flat Panel Displays
- General Purpose Constant Current Source

## Typical Applications Circuit

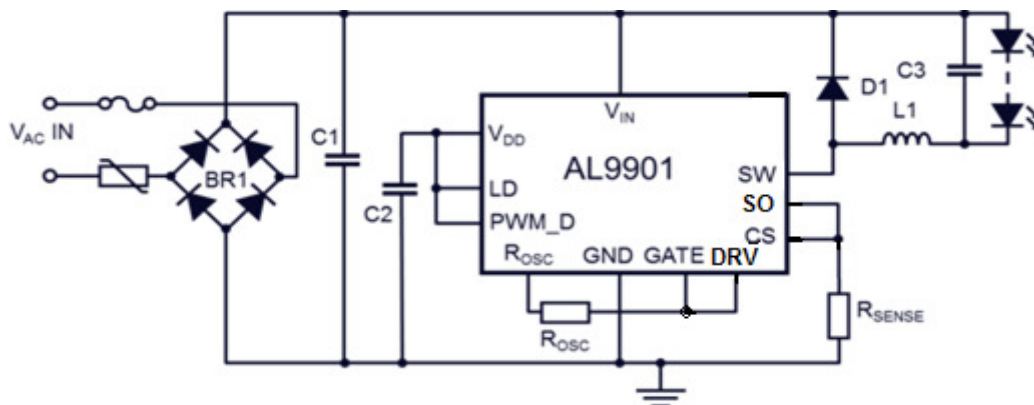

## Pin Descriptions

Pin Name	U-DFN5040-10	SO-16	Functions
Gate	1	14	Gate of Internal MOSFET switch.
NC	2	1, 2, 4, 10,16	No connection
PWM	3	5	Low Frequency PWM Dimming pin, also Enable input. Internal 200kΩ pull-down to GND
V <sub>DD</sub>	4	6	Internally regulated supply voltage, 7.5V nominal. Can supply up to 1 mA for external circuitry. A sufficient storage capacitor is used to provide storage when the rectified AC input is near the zero crossing.
LD	5	7	Linear Dimming input. Changes the current limit threshold at current sense comparator and changes the average LED current.
R <sub>osc</sub>	6	8	Oscillator control. A resistor connected between this pin and ground puts the AL9901 into fixed frequency mode and sets the switching frequency. A resistor connected between this pin and Gate pin puts the AL9901 into fixed off-time mode and determines the off-time.
V <sub>IN</sub>	7	9	Input voltage
CS	8	11	Senses LED string and internal MOSFET switch current
GND	9	12	Device ground
DRV	10	13	Gate driver output. Connect a resistor between this pin and R <sub>osc</sub> pin to put the AL9901 into fixed off time mode.
SO	11	15	Source of the internal MOSFET Switch
SW	12	3	Drain of the internal MOSFET switch.
EP1	EP1	NA	Exposed Pad 1(bottom). Drain connection of internal power MOSFET.
EP2	EP2	NA	Exposed Pad 2 (bottom). Substrate connection of control IC. Connect to GND directly underneath the package and large PCB area to minimise junction to ambient thermal impedance.

## Functional Block Diagram

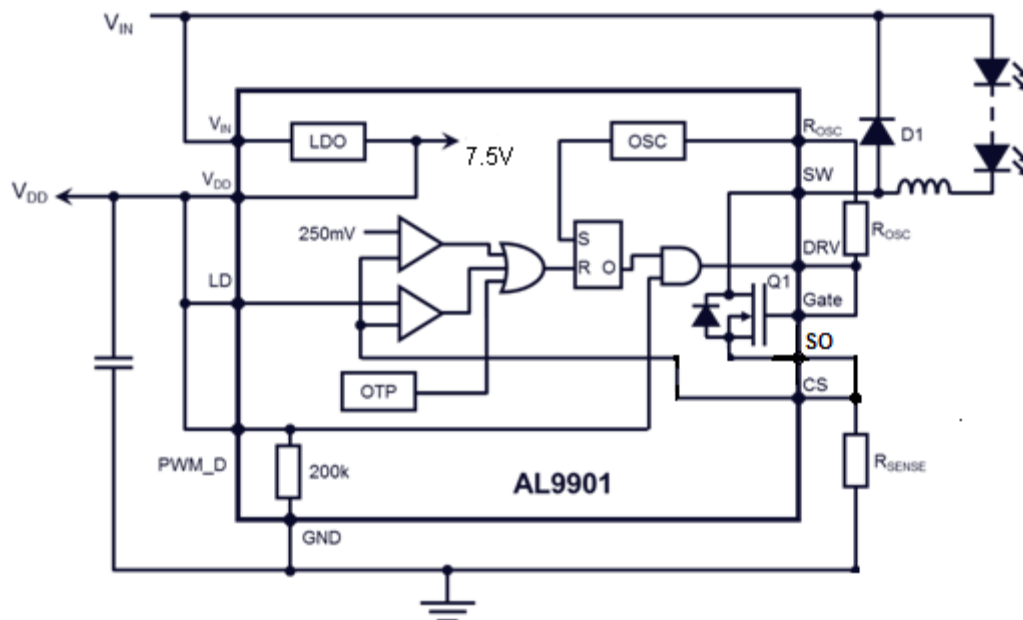

### Absolute Maximum Ratings (Note 4) (@T<sub>A</sub> = +25°C, unless otherwise specified.)

Symbol	Parameter	Ratings	Unit
V <sub>IN(MAX)</sub>	Maximum Input Voltage, V <sub>IN</sub> , to GND	-0.5 to +520	V
V <sub>CS</sub>	Maximum CS Input Pin voltage Relative to GND	-0.3 to +0.45	V
V <sub>LD</sub>	Maximum LD Input Pin Voltage Relative to GND	-0.3 to (V <sub>DD</sub> +0.3)	V
V <sub>PWM_D</sub>	Maximum PWM_D input Pin Voltage Relative to GND	-0.3 to (V <sub>DD</sub> +0.3)	V
V <sub>SW</sub>	Maximum MOSFET Drain Pin Voltage Relative to GND	-0.5 to +650	V
V <sub>SO</sub>	Maximum MOSFET Source Pin Voltage Relative to GND	-0.5 to (V <sub>DD</sub> +0.3)	V
V <sub>Gate</sub>	Maximum MOSFET GATE pin Voltage Relative to GND	-0.5 to (V <sub>DD</sub> +0.3)	V
V <sub>DD(MAX)</sub>	Maximum V <sub>DD</sub> Pin Voltage Relative to GND	8.1	V
P <sub>DIS</sub>	Continuous Power Dissipation (T <sub>A</sub> = +25°C)	-	-
-	U-DFN6040-12 (derate 10mW/°C above +25°C)	1,000	mW
T <sub>J</sub>	Junction Temperature Range	+150	°C
T <sub>ST</sub>	Storage Temperature Range	-65 to +150	°C
ESD HBM	Human Body Model ESD Protection (Note 5)	2,000	V

- Notes:
- Stresses above those listed under Absolute Maximum Ratings may cause permanent damage to the device. This is a stress rating only; functional operation of the device at these or any other conditions above those listed in the operational sections of this specification is not implied. Exposure to absolute maximum rating conditions for extended periods may affect device reliability. All voltages are with respect to Ground. Currents are positive into, negative out of the specified terminal.
  - Semiconductor devices are ESD sensitive and may be damaged by exposure to ESD events. Suitable ESD precautions should be taken when handling and transporting these devices

### Maximum Ratings of Internal MOSFET (@T<sub>A</sub> = +25°C, unless otherwise specified.)

Characteristic	Symbol	Value	Units	
Drain-Source Voltage	V <sub>DSS</sub>	650	V	
Gate-Source Voltage	V <sub>GSS</sub>	±30	V	
Continuous Drain Current (Note 5) V <sub>GS</sub> = 10V	Steady State	T <sub>C</sub> = +25°C	1.6	A
		T <sub>C</sub> = +100°C	1	A
Pulsed Drain Current (Note 6)	I <sub>DM</sub>	3	A	
Avalanche Current (Note 7) V <sub>DD</sub> = 100V, V <sub>GS</sub> = 10V, L = 60mH	I <sub>AR</sub>	0.8	A	
Repetitive Avalanche Energy (Note 7) V <sub>DD</sub> = 100V, V <sub>GS</sub> = 10V, L = 60mH	E <sub>AR</sub>	22	mJ	
Peak Diode Recovery	dv/dt	5	V/ns	

### Recommended Operating Conditions (@T<sub>A</sub> = +25°C, unless otherwise specified.)

Symbol	Parameter	Min	Max	Unit
V <sub>INDC</sub>	Input DC Supply Voltage Range	15	500	V
T <sub>A</sub>	Ambient Temperature Range (U-DFN6040-12)	-40	+105	°C
T <sub>A</sub>	Ambient Temperature Range (SO-16)	-40	+85	-
I <sub>SW</sub>	Switch Pin Output Current	-	0.4	A
V <sub>DD</sub>	Maximum Recommended Voltage Applied to V <sub>DD</sub> Pin (Note 6)	-	8.1	V
V <sub>EN(lo)</sub>	Pin PWM_D Input Low Voltage	0	1	V
V <sub>EN(hi)</sub>	Pin PWM_D Input High Voltage	2.4	V <sub>DD</sub>	

- Note: 6. When using the AL9901 in isolated LED lamps, an auxiliary winding might be used.

## Electrical Characteristics (@T<sub>A</sub> = +25 °C, unless otherwise specified.)

Specifications apply to AL9901 unless otherwise specified

Symbol	Parameter	Conditions	Min	Typ	Max	Unit
I <sub>Insd</sub>	Shut-Down Mode Supply Current	Pin PWM_D to GND, V <sub>IN</sub> = 15V	-	0.5	1	mA
V <sub>DD</sub>	Internally Regulated Voltage	V <sub>IN</sub> = V <sub>IN(MIN)</sub> ~ 500V, (Note 8) I <sub>DD(ext)</sub> = 0, Gate pin open	7.2	7.5	8.1	V
I <sub>DD(ext)</sub>	V <sub>DD</sub> Current Available for External Circuitry	V <sub>IN</sub> = 15 to 100V (Note 7)	-	-	1.0	mA
UVLO	V <sub>DD</sub> Under Voltage Lockout Threshold	V <sub>DD</sub> rising	6.4	6.7	7.2	V
ΔUVLO	V <sub>DD</sub> Under Voltage Lockout Hysteresis	V <sub>DD</sub> falling	-	500	-	mV
R <sub>PWM_D</sub>	PWM_D Pull-Down Resistance	V <sub>PWM_D</sub> = 5V	150	200	250	kΩ
V <sub>T</sub>	MOSFET Threshold Voltage	I <sub>SW</sub> = 0.5A	-	3	-	V
V <sub>FD</sub>	MOSFET Diodes Forward Voltage	I <sub>D</sub> = 0.5A	-	0.85	-	V
R <sub>DS(ON)</sub>	Drain-Source On-Resistance	-	-	4.4	-	Ω
V <sub>CS(hi)</sub>	Current Sense Threshold Voltage	T <sub>A</sub> = -40 °C to +125 °C	237.5	250	262.5	mV
f <sub>OSC</sub>	Oscillator Frequency	R <sub>OSC</sub> = 1MΩ	20	25	30	kHz
		R <sub>OSC</sub> = 226kΩ	80	100	120	
D <sub>MAXhf</sub>	Maximum Oscillator PWM Duty Cycle	f <sub>PWMhf</sub> = 25kHz, at GATE, CS to GND.	-	-	100	%
V <sub>LD</sub>	Linear Dimming Pin Voltage Range	T <sub>A</sub> = <125 °C, V <sub>IN</sub> = 15V	0	-	250	mV
t <sub>BLANK</sub>	Current Sense Blanking Interval	V <sub>CS</sub> = 0.45V, V <sub>LD</sub> = V <sub>DD</sub>	160	250	440	ns
t <sub>DELAY</sub>	Delay From CS Trip to GATE lo	V <sub>IN</sub> = 15V, V <sub>LD</sub> = 0.15, V <sub>CS</sub> = 0 to 0.22V after T <sub>BLANK</sub>	-	-	300	ns
T <sub>SD</sub>	Thermal Shut-Down	-	-	+150	-	°C
T <sub>SDH</sub>	Thermal Shut-Down Hysteresis	-	-	+50	-	
θ <sub>JA</sub>	Thermal Resistance Junction-to-Ambient	U-DFN6040-12 (Note 8)	-	65	-	°C/W
θ <sub>JC</sub>	Thermal Resistance Junction-to-Case		-	5	-	°C/W
θ <sub>JA</sub>	Thermal Resistance Junction-to-Ambient	SOIC-16	-	100	-	°C/W
θ <sub>JC</sub>	Thermal Resistance Junction-to-Case		-	15	-	°C/W

- Notes:
- Also limited by package power dissipation capability, whichever is lower.
  - Device mounted on FR-4 PCB (25mm x 25mm 1oz copper, minimum recommended pad layout on top. For better thermal performance, larger copper pad for heat-sink is needed.

Internal MOSFET Characteristic	Symbol	Min	Typ	Max	Unit	Test Condition
<b>OFF CHARACTERISTICS (Note 9)</b>						
Drain-Source Breakdown Voltage	$BV_{DSS}$	650	—	—	V	$V_{GS} = 0V, I_D = 250\mu A$
Zero Gate Voltage Drain Current	$I_{DSS}$	—	—	1	$\mu A$	$V_{DS} = 650V, V_{GS} = 0V$
Gate-Source Leakage	$I_{GSS}$	—	—	$\pm 100$	nA	$V_{GS} = \pm 30V, V_{DS} = 0V$
<b>ON CHARACTERISTICS (Note 9)</b>						
Gate Threshold Voltage	$V_{GS(th)}$	3	—	5	V	$V_{DS} = V_{GS}, I_D = 250\mu A$
Static Drain-Source On-Resistance	$R_{DS(ON)}$	—	4	5	$\Omega$	$V_{GS} = 10V, I_D = 1A$
Diode Forward Voltage	$V_{SD}$	—	0.7	1	V	$V_{GS} = 0V, I_S = 1A$
<b>DYNAMIC CHARACTERISTICS (Note 10)</b>						
Input Capacitance	$C_{iss}$	—	479	—	pF	$V_{DS} = 25V, V_{GS} = 0V,$ $f = 1MHz$
Output Capacitance	$C_{oss}$	—	29	—	pF	
Reverse Transfer Capacitance	$C_{rss}$	—	1.9	—	pF	
Gate Resistance	$R_g$	—	2	—	$\Omega$	$V_{DS} = 0V, V_{GS} = 0V, f = 1MHz$
Total Gate Charge	$Q_g$	—	14	—	nC	$V_{DS} = 520V, V_{GS} = 10V,$ $I_D = 2A$
Gate-Source Charge	$Q_{gs}$	—	2.5	—	nC	
Gate-Drain Charge	$Q_{gd}$	—	7.3	—	nC	
Turn-On Delay Time	$t_{D(on)}$	—	17	—	ns	$V_{DS} = 325V, V_{GS} = 10V,$ $R_G = 25\Omega, I_D = 2.5A$
Turn-On Rise Time	$t_r$	—	33	—	ns	
Turn-Off Delay Time	$t_{D(off)}$	—	31	—	ns	
Turn-Off Fall Time	$t_f$	—	25	—	ns	
Body Diode Reverse Recovery Time	$t_{rr}$	—	174	—	ns	$V_{DS} = 100V, I_F = 2A,$ $di/dt = 100A/\mu s$
Body Diode Reverse Recovery Charge	$Q_{rr}$	—	884	—	nC	

Notes: 9. Short duration pulse test used to minimize self-heating effect.  
 10. Guaranteed by design. Not subject to production testing.

**Typical Characteristics**

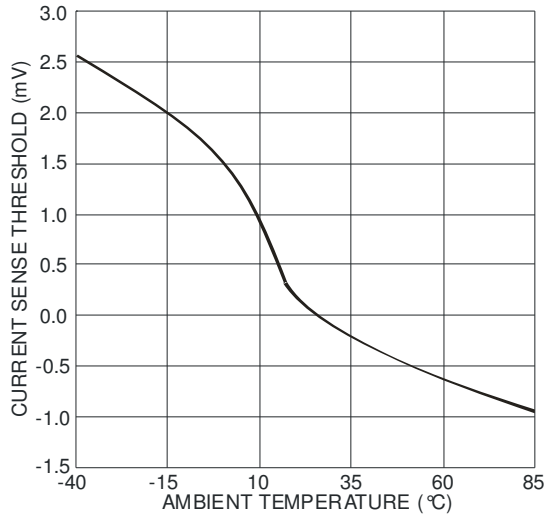

Change in Current Sense Threshold vs. Ambient Temperature

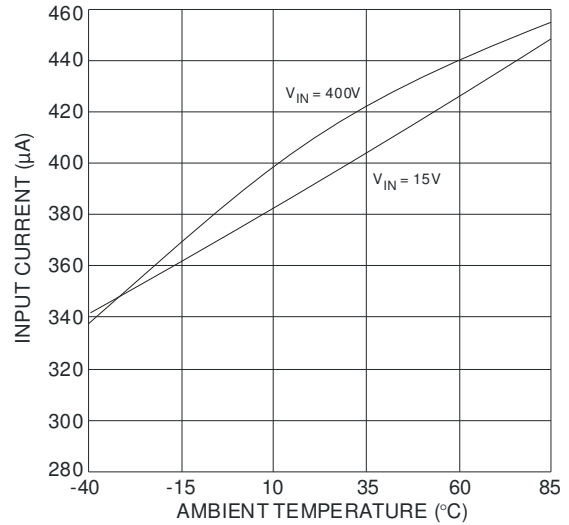

Input Current vs. Ambient Temperature

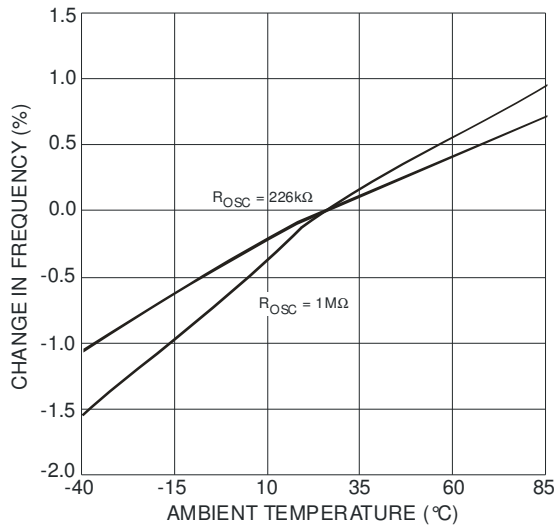

Change in Oscillation Frequency vs. Ambient Temperature

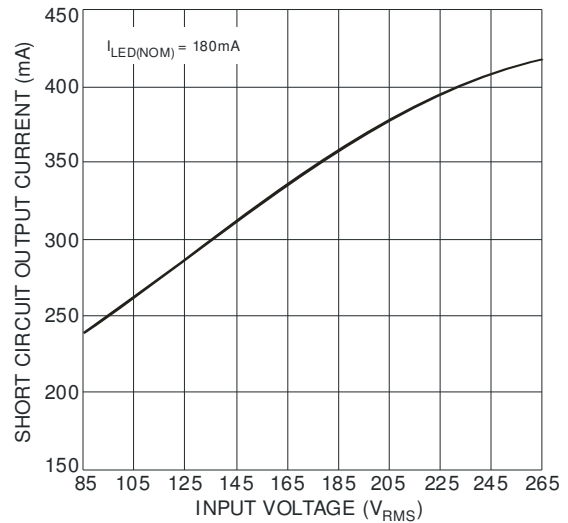

180mA LED Driver Short Circuit Output Current vs. Input Voltage

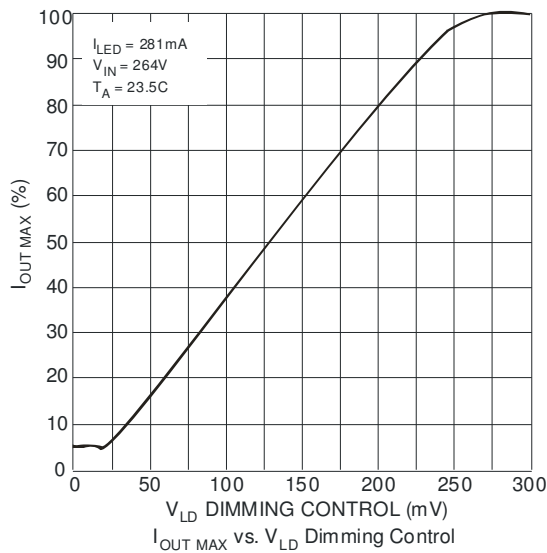

IOUT MAX vs. VLD Dimming Control

**Typical Characteristics** (continued) measured using AL9901EV4

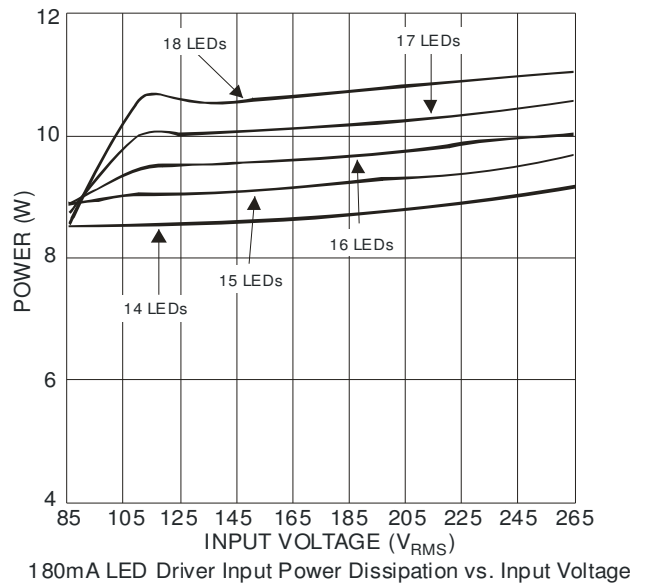
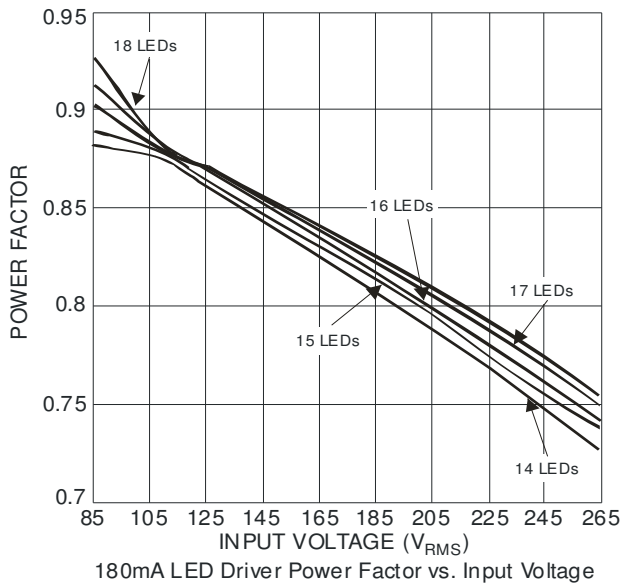
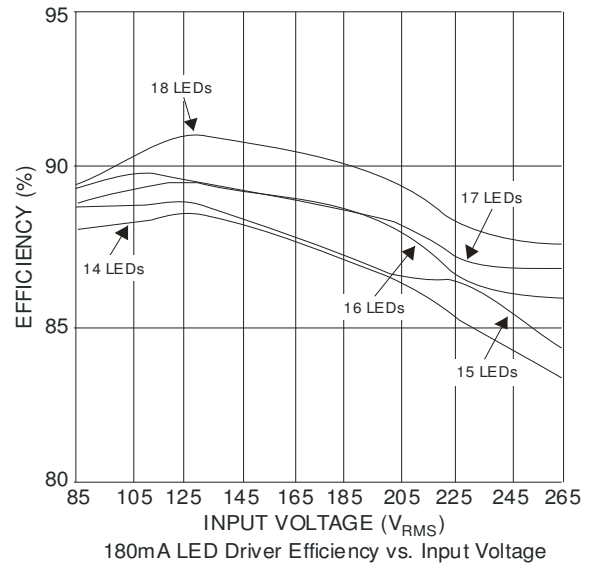
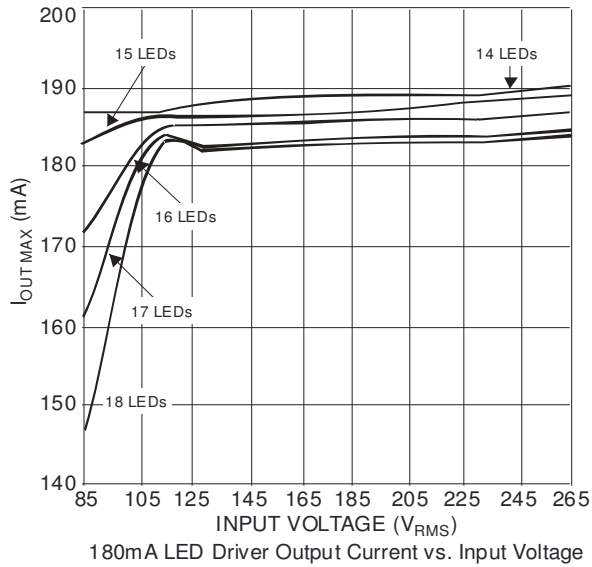

**Typical Characteristics (cont.) measured using internal MOSFET**

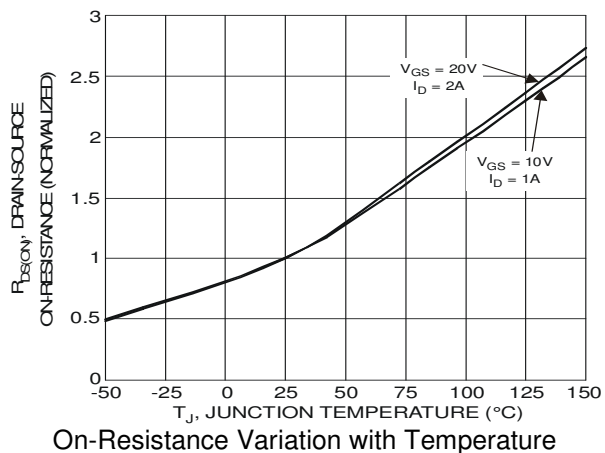
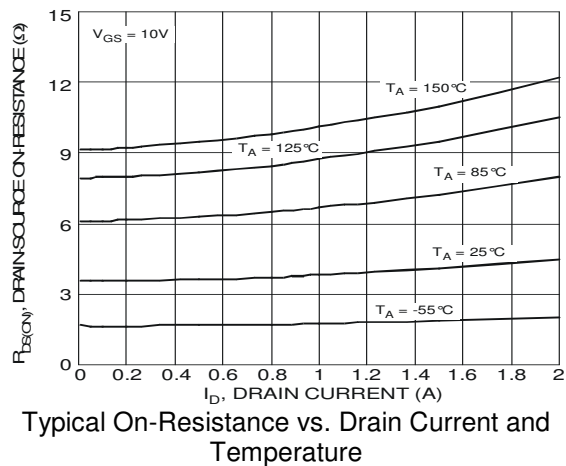
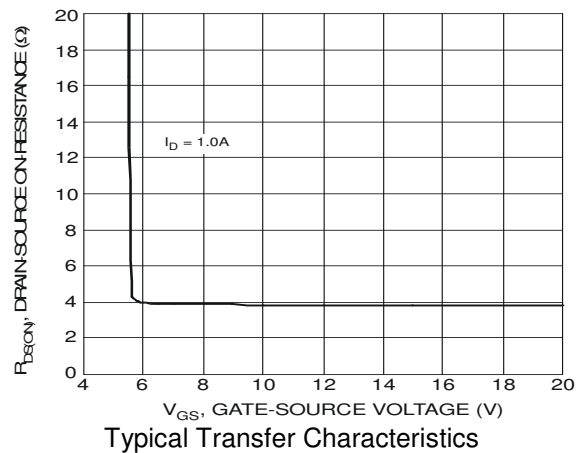
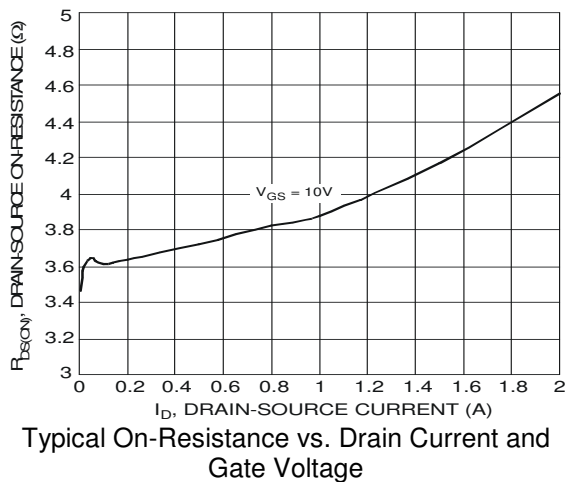
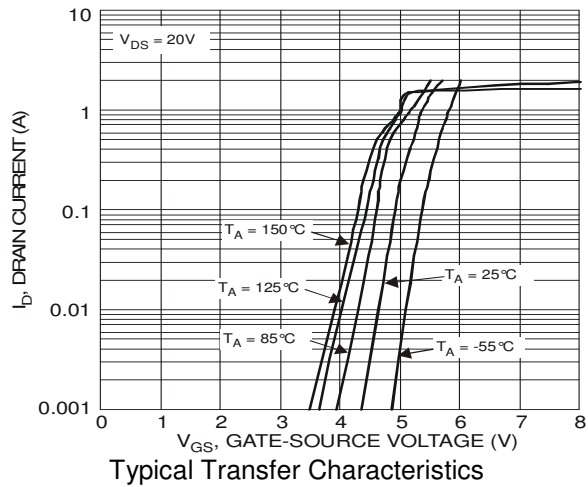
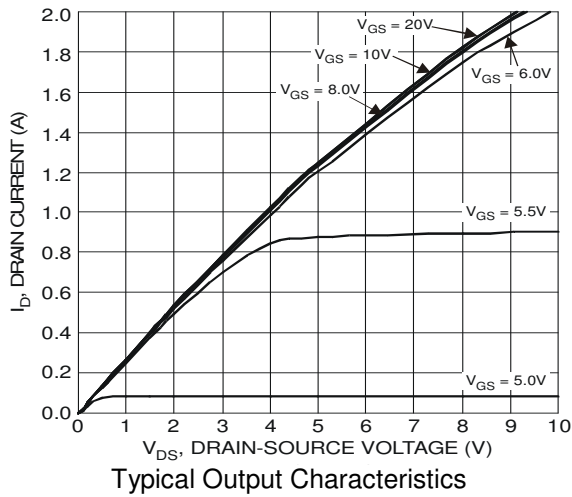

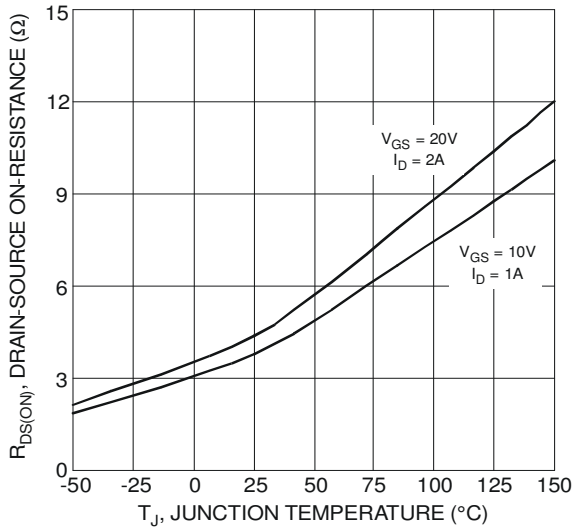

On-Resistance Variation with Temperature

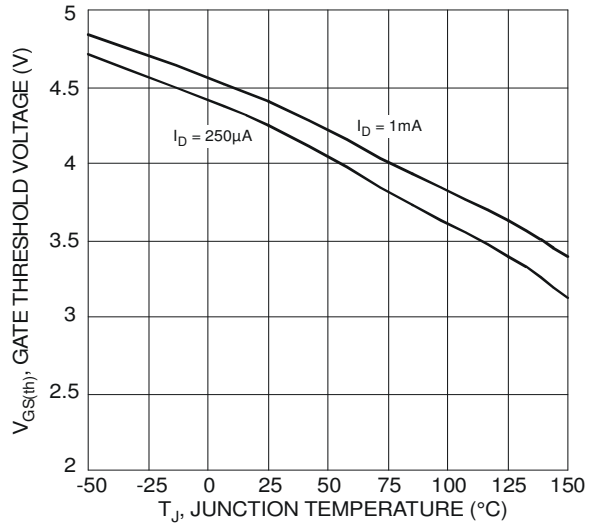

Gate Threshold Variation vs. Ambient Temperature

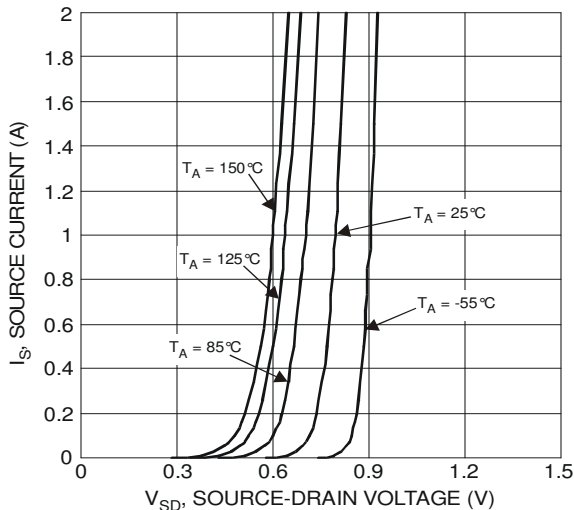

Diode Forward Voltage vs. Current

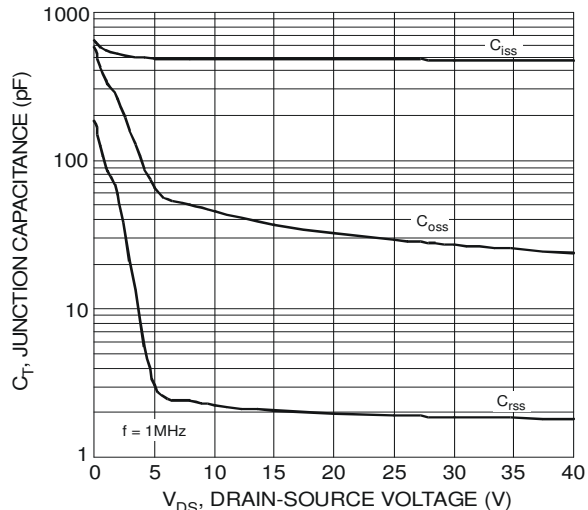

Typical Junction Capacitance

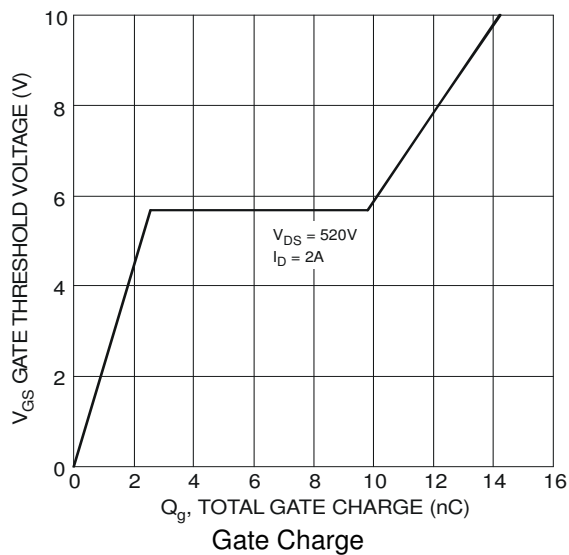

Gate Charge

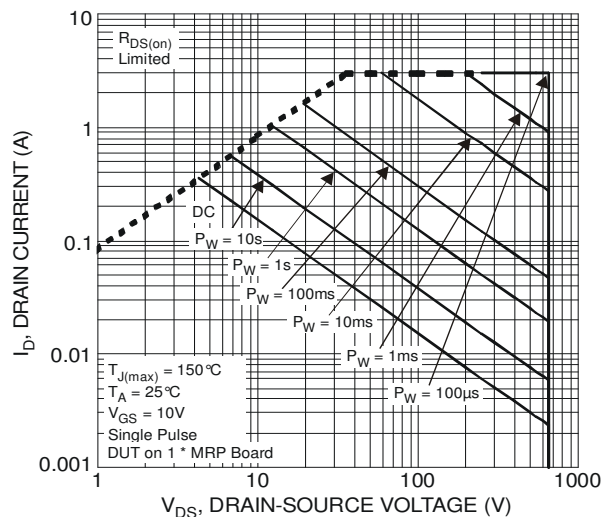

SOA, Safe Operation Area

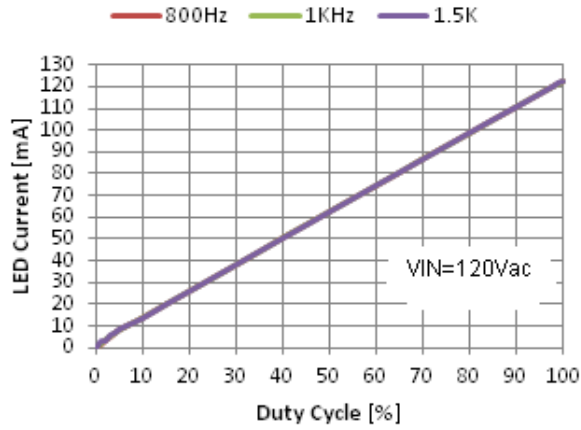

LED Current vs. Duty Cycle by PWM Dimming when VIN is 120Vac

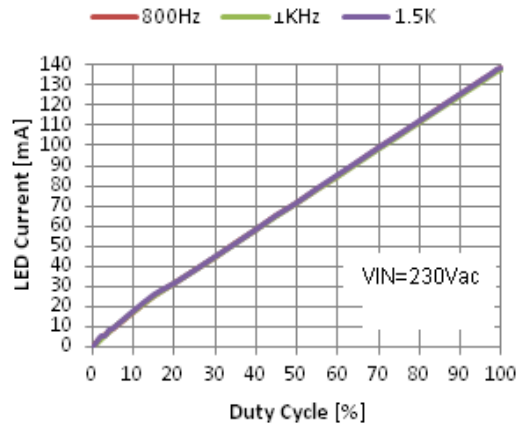

LED Current vs. Duty Cycle by PWM Dimming when VIN is 230Vac

## Applications Information

The AL9901 is capable of operating in isolated or non-isolated topologies. It can also be made to operate in continuous as well as discontinuous conduction mode.

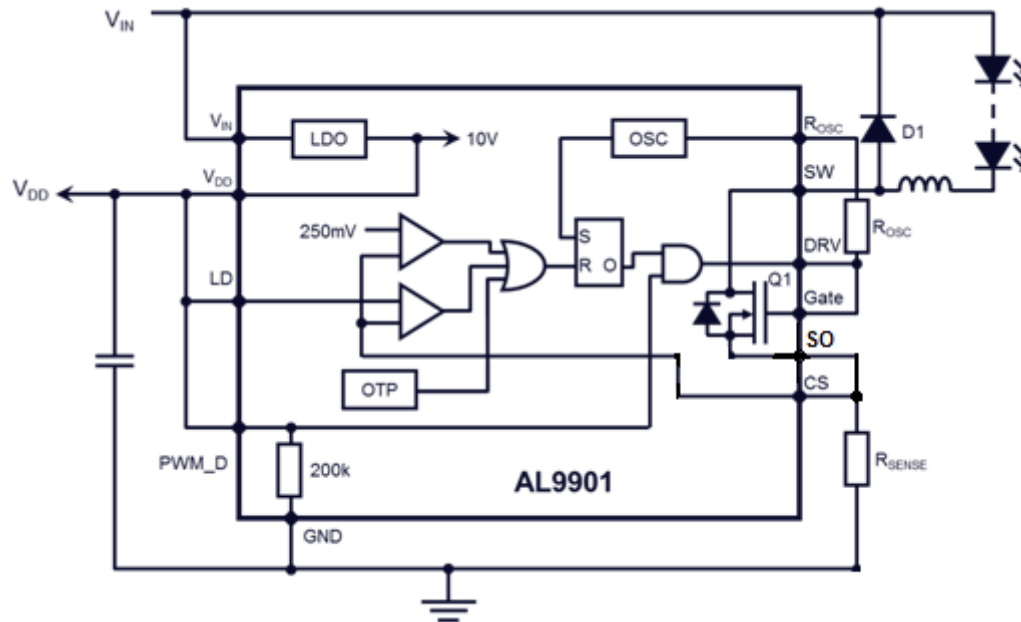

**Figure 1 Functional Block Diagram**

The AL9901 contains a high voltage LDO (see figure 1) the output of the LDO provides a power rail to the internal circuitry including the gate driver. A UVLO on the output of the LDO prevents incorrect operation at low input voltage to the V<sub>IN</sub> pin.

In a non-isolated Buck LED driver, when the gate pin goes high, the internal power MOSFET (Q1) is turned on causing current to flow through the LEDs inductor (L1), and current sense resistor (R<sub>SENSE</sub>). When the voltage across R<sub>SENSE</sub> exceeds the current sense pin threshold, the internal MOSFET Q1 is turned off. The energy stored in the inductor causes the current to continue to flow through the LEDs via diode D1.

The AL9901's LDO provides all power to the rest of the IC including Gate drive, and this removes the need for large, high-power start-up resistors. This means that during normal operation the AL9901 requires around 0.5mA from the high voltage power rail. The LDO can also be used to supply up to 1mA to external circuits.

The AL9901 operates and regulates by limiting the peak current of the internal MOSFET; the peak current sense threshold is nominally set at 250mV. The AL9901 is capable of operating in a fixed frequency (PWM) mode and also variable frequency (fixed off-time) mode to regulate the LED current.

The same basic operation is true for isolated topologies; however in these the energy stored in the transformer delivers energy to LEDs during the off-cycle of the internal MOSFET.

The on-resistance of the AL9901's internal power MOSFET means that it can drive up to 2A.

### Design Parameters

#### Setting the LED Current

In the non-isolated buck converter topology, figure 1, the average LED current is not the peak current divided by two - however, there is a certain error due to the difference between the peak and the average current in the inductor. The following equation accounts for this error:

$$R_{SENSE} = \frac{250mV}{I_{LED} + (0.5 * I_{RIPPLE})}$$

## Applications Information (continued)

### Setting Operating Frequency

The AL9901 is capable of operating between 25 and 450 kHz switching frequency range. The switching frequency is programmed by connecting an external resistor between  $R_{OSC}$  pin and ground. The corresponding oscillator period is:

$$t_{OSC} = \frac{R_{OSC} + 22}{25} \mu s \quad \text{with } R_{OSC} \text{ in } k\Omega$$

The switching frequency is the reciprocal of the oscillator period. Typical values for  $R_{OSC}$  vary from 75k $\Omega$  to 1M $\Omega$ .

In buck mode the duty cycle, D, is  $\frac{V_{LEDS}}{V_{IN}}$ ; so when driving small numbers of LEDs from high input voltages the duty cycle will be reduced and

care should be taken to ensure that  $t_{ON} > t_{BLANK}$ . The simplest way to do this is to reduce/limit the switching frequency by increasing the  $R_{OSC}$  value. Reducing the switching frequency will also improve the efficiency.

When operating in buck mode the designer must keep in mind that the input voltage must be maintained higher than two times the forward voltage drop across the LEDs. This limitation is related to the output current instability that may develop when the AL9901 operates at a duty cycle greater than 0.5. This instability reveals itself as an oscillation of the output current at a sub-harmonic (SBO) of the switching frequency.

### Inductor Selection

The non-isolated buck circuit, Figure 1, is usually selected and it has two operation modes: continuous and discontinuous conduction modes. A buck power stage can be designed to operate in continuous mode for load current above a certain level, usually 15% to 30% of full load. Usually, the input voltage range, the output voltage and load current are defined by the power stage specification. This leaves the inductor value as the only design parameter to maintain continuous conduction mode. The minimum value of inductor to maintain continuous conduction mode can be determined by the following example.

The required inductor value is determined from the desired peak-to-peak LED ripple current in the inductor; typically around 30% of the nominal LED current.

$$L = \frac{(V_{IN} - V_{LEDS}) \times D}{(0.3 \times I_{LED}) \times f_{OSC}} \quad \text{Where, D is duty cycle}$$

The next step is determining the total voltage drop across the LED string. For example, when the string consists of 10 High-Brightness LEDs and each diode has a forward voltage drop of 3.0V at its nominal current; the total LED voltage  $V_{LEDS}$  is 30V.

### Dimming

The LED brightness can be dimmed either linearly (using the LD pin) or via pulse width modulation (using the PWM-D pin); or a combination of both - depending on the application. Pulling the PWM\_Dpin to ground will turn off the AL9901. When disabled, the AL9901's quiescent current is typically 0.5mA (0.65 for AL9901A). Reducing the LD voltage will reduce the LED current but it will not entirely turn off the external power transistor and hence the LED current – this is due to the finite blanking period. Only the PWM\_Dpin will turn off the power transistor.

Linear dimming is accomplished by applying a 45 to 250mV analog signal to the LD pin. This overrides the default 250mV threshold level of the CS pin and reduces the output current. If an input voltage greater than 250mV is applied to the LD then the output current will not change.

The LD pin also provides a simple cost effective solution to soft start. By connecting a capacitor to the LD pin down to ground at initial power up, the LD pin will be held low, causing the sense threshold to be low. As the capacitor charges up the current sense threshold will increase, thereby causing the average LED current to increase.

PWM dimming is achieved by applying an external PWM signal to the PWM\_D pin. The LED current is proportional to the PWM duty cycle and the light output can be adjusted between 0 and 100%. The PWM signal enables and disables the AL9901 - modulating the LED current. The ultimate accuracy of the PWM dimming method is limited only by the minimum gate pulse width, which is a fraction of a percentage of the low frequency duty cycle. PWM dimming of the LED light can be achieved by turning on and off the converter with a low frequency 50Hz to 1000Hz TTL logic level signal.

With both modes of dimming it is not possible to achieve average brightness levels higher than the one set by the current sense threshold level of the AL9901. If a greater LED current is required, then a smaller sense resistor should be used.

**Applications Information** (cont.)

**Output Open Circuit Protection**

The non-isolated buck LED driver topology provides inherent protection against an open circuit condition in the LED string due to the LEDs being connected in series with the inductor. Should the LED string become open circuit then no switching occurs and the circuit can be permanently left in this state with damage to the rest of the circuit.

**AC/DC Off-Line LED Driver**

The AL9901 is a cost-effective off-line buck LED driver-converter specifically designed for driving LED strings. It is suitable for being used with either a rectified AC line or any DC voltage between 15-500V. See figure 3 for typical circuit.

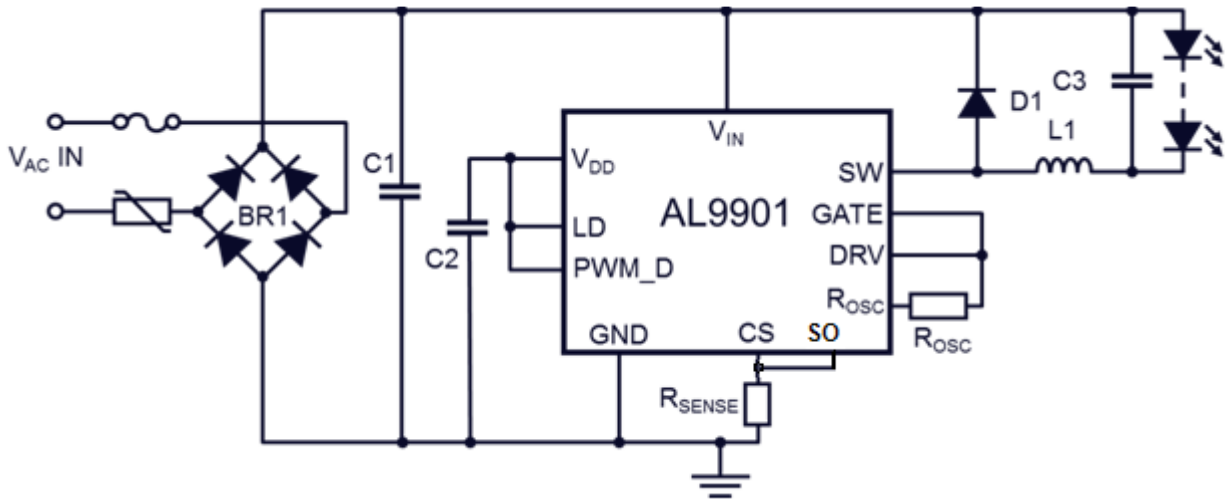

**Figure 2 Typical Application Circuit (without PFC)**

**Buck Design Equations:**

$$D = \frac{V_{LEDs}}{V_{IN}}$$

$$t_{ON} = \frac{D}{f_{osc}}$$

$$L \geq \frac{(V_{IN} - V_{LEDs}) \times t_{ON}}{0.3 \times I_{LED}}$$

$$R_{SENSE} = \frac{0.25}{I_{LED} + (0.5 \times (I_{LED} \times 0.3))} \text{ Where } I_{LED} \times 0.3 = I_{RIPPLE}$$

**Design Example**

For an AC line voltage of 120V the nominal rectified input voltage is  $V_{IN} = 120V \times 1.41 = 169V$ . From this and the LED chain voltage, the duty cycle can be determined:

$$D = V_{LEDs} / V_{IN} = 30 / 169 = 0.177$$

From the switching frequency, for example  $f_{OSC} = 50 \text{ kHz}$ , the required on-time of the internal MOSFET can be calculated:

$$t_{ON} = D / f_{OSC} = 3.5 \mu s$$

The value of the inductor is determined as follows:

$$L = (V_{IN} - V_{LEDs}) \times t_{ON} / (0.3 \times I_{LED}) = 4.6mH$$

## Applications Information (cont.)

### Input Bulk Capacitor

For offline lamps, an input bulk capacitor is required to ensure that the rectified AC voltage is held above twice the LED string voltage throughout the AC line cycle. The value can be calculated from:

$$C_{IN} \geq \frac{P_{in} \times (1 - D_{ch})}{\sqrt{2} \times V_{Line\_min} \times 2f_L \times \Delta V_{DC\_max}}$$

Where:

$D_{ch}$  : Capacity charge work period, generally about 0.2~0.25

$f_L$  : Input frequency for full range (85~265V<sub>RMS</sub>)

$\Delta V_{DC\_max}$  Should be set 10~15% of  $\sqrt{2}V_{Line\_min}$

If the capacitor has a 15% voltage ripple, then a simplified formula for the minimum value of the bulk input capacitor approximates to:

$$C_{MIN} = \frac{I_{LED} \times V_{LEDs} \times 0.06}{V_{IN}^2}$$

### Power Factor Correction

If power factor improvement is required, then for the input power less than 25W, a simple method for improving the power factor can be implemented by potential dividing down the rectified mains voltage (resistors R1 and R2 in Figure 4) and feeding it into the LD pin. The current drawn from the supply voltage will follow an approximate half sine wave. A filter across the LEDs reduces the potential for flicker. This circuit also significantly reduces the size of input capacitors.

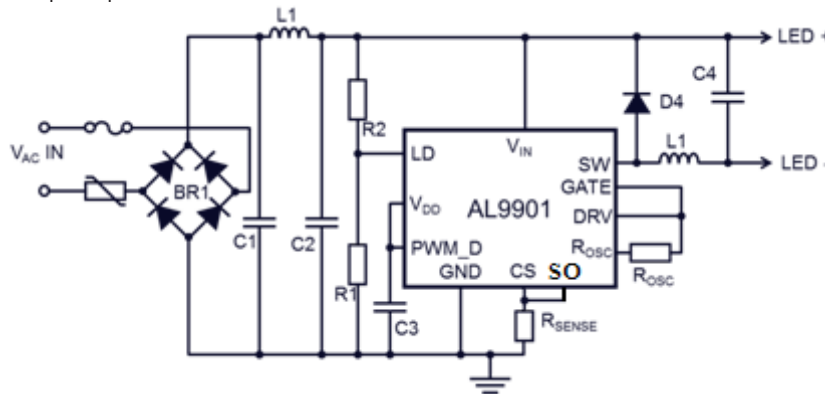

**Figure 3 Typical Application Circuit with Simple PFC**

Passive power factor correction using three high voltage diodes and two identical capacitors can be implemented. For further design information, please see AN75 from the Diodes website.

### DC-DC Buck LED Driver

The design procedure for an AC input buck LED driver outlined in the previous chapters equally applies to DC input LED drivers.

**Applications Information** (cont.)

**DC-DC Boost LED Driver**

Due to the topology of the AL9901 LED driver-converter, it is capable of being used in boost configurations – at reduced accuracy. The accuracy can be improved by measuring the LED current with an op amp and use the op amp’s output to drive the LD pin.

A Boost LED driver is used when the forward voltage drop of the LED string is higher than the input supply voltage. For example, the Boost topology can be appropriate when input voltage is supplied by a 48V power supply and the LED string consists of twenty HB LEDs, as the case may be for a street light.

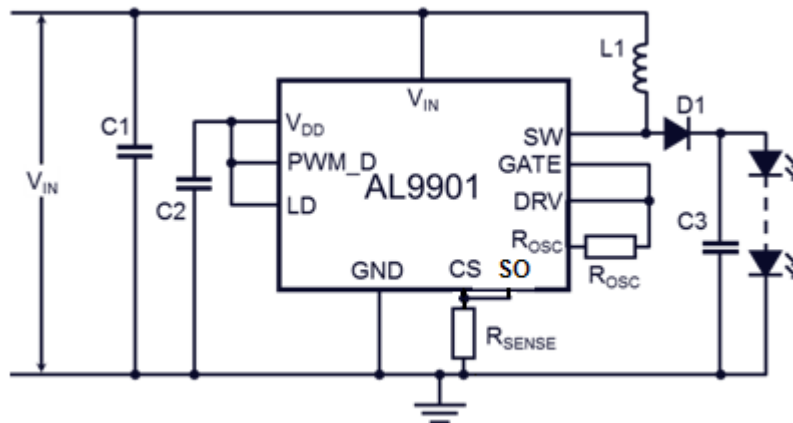

**Figure 4 Boost LED driver**

In a Boost converter, when the internal MOSFET is ON the energy is stored in the inductor which is then delivered to the output when the internal MOSFET switches OFF. If the energy stored in the inductor is not fully depleted by the next switching cycle (continuous conduction mode), the DC conversion between input and output voltage is given by:

$$V_{OUT} = \frac{V_{IN}}{1-D} \rightarrow D = \frac{V_{OUT} - V_{IN}}{V_{OUT}}$$

From the switching frequency,  $f_{OSC}$ , the on-time of the MOSFET can be calculated:

$$t_{ON} = \frac{D}{f_{OSC}}$$

From this the required inductor value can be determined by:

$$L = \frac{V_{IN} * t_{ON}}{0.3 * I_{LED}}$$

The Boost topology LED driver requires an output capacitor to deliver current to the LED string during the time that the internal MOSFET is on.

In boost LED driver topologies, if the LEDs should become open circuit, damage may occur to the power switch and so some form of detection should be present to provide overvoltage detection/protection.

**Ordering Information**

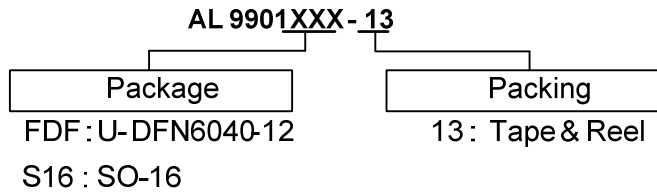

Part Number	V <sub>CS</sub> Tolerance	Package Code	Packaging	13" Tape and Reel	
				Quantity	Part Number Suffix
AL9901FDF-13	±5%	FDF	U-DFN6040-12	3,000/Tape & Reel	-13
AL9901S16-13	±5%	S16	SO-16	2,500/Tape & Reel	-13

**Marking Information**

PKG	P/N	Marking Code
SOIC-16L	AL9901S16-13	AL9901
DFN6040-12	AL9901FDF-13	AL9901

**(1) U-DFN6040-12**

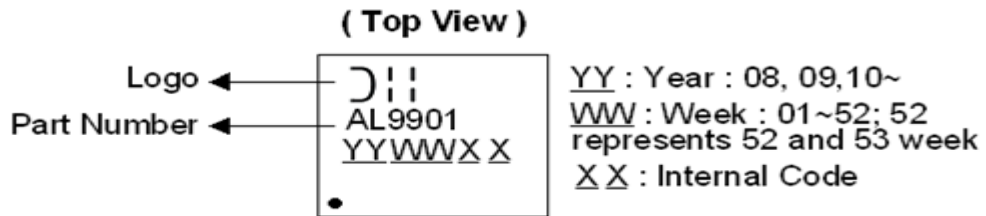

**(2) SO-16**

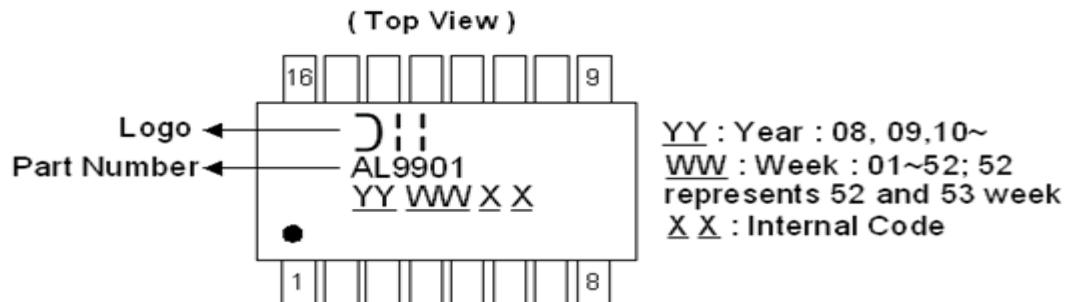

**Package Outline Dimensions** (All dimensions in mm.)

Please see AP02002 at <http://www.diodes.com/datasheets/ap02002.pdf> for the latest version.

(1) U-DFN6040-12

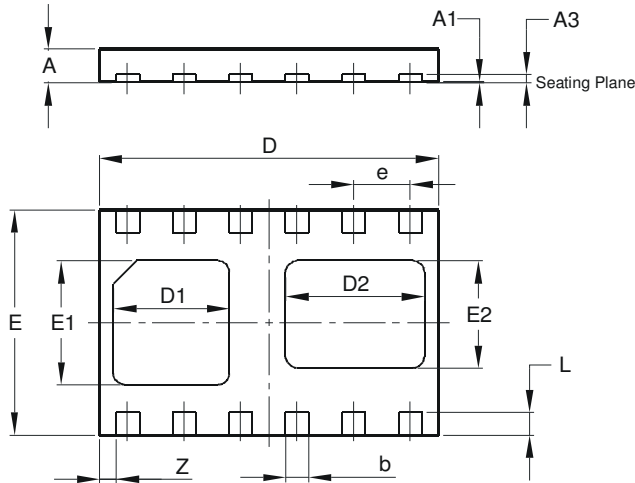

U-DFN6040-12			
Dim	Min	Max	Typ
A	0.55	0.65	0.60
A1	0	0.05	0.02
A3	-	-	0.15
b	0.35	0.45	0.40
D	5.95	6.05	6.00
D1	1.95	2.15	2.05
D2	2.35	2.55	2.45
e	-	-	1.00
E	3.95	4.05	4.00
E1	2.10	2.30	2.20
E2	1.80	2.00	1.90
L	0.35	0.45	0.40
Z	-	-	0.30
<b>All Dimensions in mm</b>			

(2) SO-16

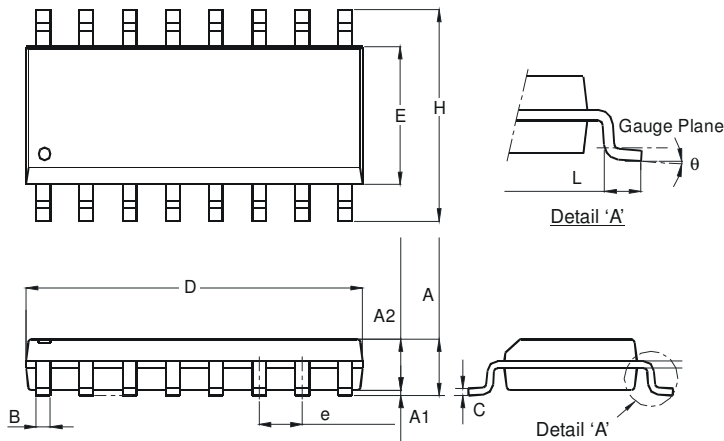

SO-16		
Dim	Min	Max
A	1.40	1.75
A1	0.10	0.25
A2	1.30	1.50
B	0.33	0.51
C	0.19	0.25
D	9.80	10.00
E	3.80	4.00
e	1.27 Typ	
H	5.80	6.20
L	0.38	1.27
$\theta$	0°	8°
<b>All Dimensions in mm</b>		

## Suggested Pad Layout

Please see AP02001 at <http://www.diodes.com/datasheets/ap02001.pdf> for the latest version.

(1) U-DFN6040-12

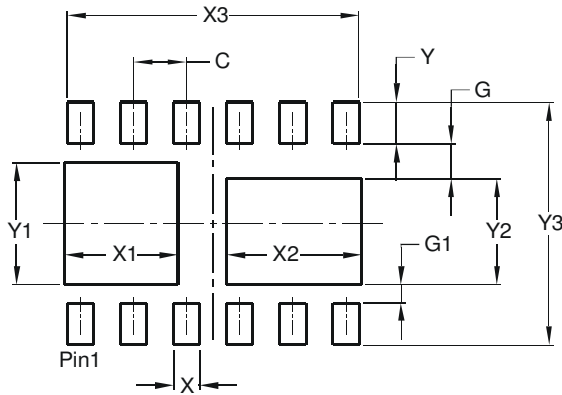

Dimensions	Value (in mm)
C	0.500
G	0.650
G1	0.350
X	0.250
X1	1.075
X2	1.275
X3	2.750
Y	0.400
Y1	1.150
Y2	1.000
Y3	2.300

(2) SO-16

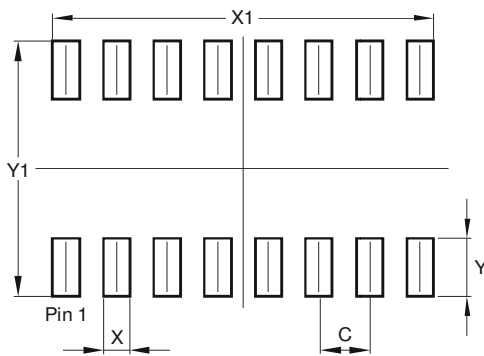

Dimensions	Value (in mm)
C	1.270
X	0.670
X1	9.560
Y	1.450
Y1	6.400

## Taping Orientation

The taping orientation of the other package type can be found on our website at <http://www.diodes.com/datasheets/ap02007.pdf>.

(1) U-DFN6040-12

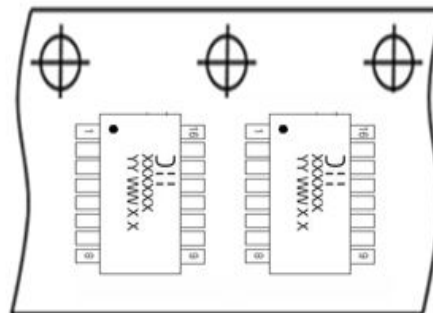
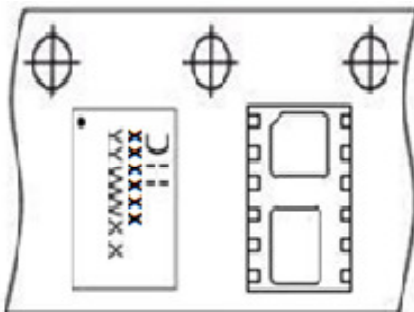

(2) SOIC-16

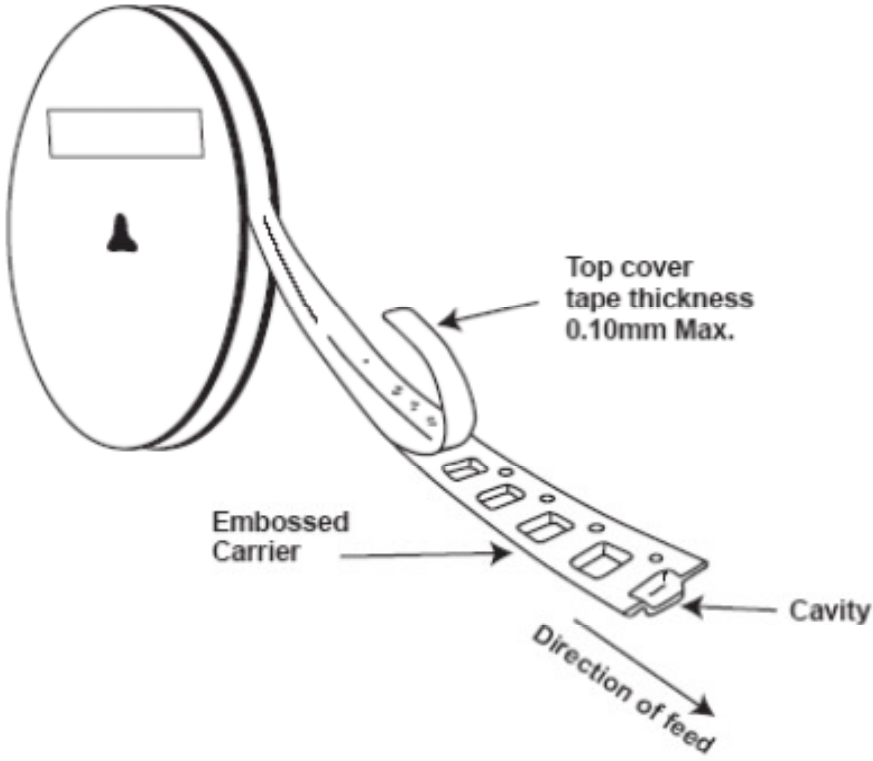

**IMPORTANT NOTICE**

DIODE INCORPORATED MAKES NO WARRANTY OF ANY KIND, EXPRESS OR IMPLIED, WITH REGARDS TO THIS DOCUMENT, INCLUDING, BUT NOT LIMITED TO, THE IMPLIED WARRANTIES OF MERCHANTABILITY AND FITNESS FOR A PARTICULAR PURPOSE (AND THEIR EQUIVALENTS UNDER THE LAWS OF ANY JURISDICTION).

Diodes Incorporated and its subsidiaries reserve the right to make modifications, enhancements, improvements, corrections or other changes without further notice to this document and any product described herein. Diodes Incorporated does not assume any liability arising out of the application or use of this document or any product described herein; neither does Diodes Incorporated convey any license under its patent or trademark rights, nor the rights of others. Any Customer or user of this document or products described herein in such applications shall assume all risks of such use and will agree to hold Diodes Incorporated and all the companies whose products are represented on Diodes Incorporated website, harmless against all damages.

Diodes Incorporated does not warrant or accept any liability whatsoever in respect of any products purchased through unauthorized sales channel. Should Customers purchase or use Diodes Incorporated products for any unintended or unauthorized application, Customers shall indemnify and hold Diodes Incorporated and its representatives harmless against all claims, damages, expenses, and attorney fees arising out of, directly or indirectly, any claim of personal injury or death associated with such unintended or unauthorized application.

Products described herein may be covered by one or more United States, international or foreign patents pending. Product names and markings noted herein may also be covered by one or more United States, international or foreign trademarks.

This document is written in English but may be translated into multiple languages for reference. Only the English version of this document is the final and determinative format released by Diodes Incorporated.

**LIFE SUPPORT**

Diodes Incorporated products are specifically not authorized for use as critical components in life support devices or systems without the express written approval of the Chief Executive Officer of Diodes Incorporated. As used herein:

A. Life support devices or systems are devices or systems which:

1. are intended to implant into the body, or
2. support or sustain life and whose failure to perform when properly used in accordance with instructions for use provided in the labeling can be reasonably expected to result in significant injury to the user.

B. A critical component is any component in a life support device or system whose failure to perform can be reasonably expected to cause the failure of the life support device or to affect its safety or effectiveness.



Customers represent that they have all necessary expertise in the safety and regulatory ramifications of their life support devices or systems, and acknowledge and agree that they are solely responsible for all legal, regulatory and safety-related requirements concerning their products and any use of Diodes Incorporated products in such safety-critical, life support devices or systems, notwithstanding any devices- or systems-related information or support that may be provided by Diodes Incorporated. Further, Customers must fully indemnify Diodes Incorporated and its representatives against any damages arising out of the use of Diodes Incorporated products in such safety-critical, life support devices or systems.

Copyright © 2015, Diodes Incorporated

[www.diodes.com](http://www.diodes.com)

## Looking for pricing, stock, or lifecycle information?

Click below to explore more details on WIN SOURCE:

-  [View AL9901S16-13 on WIN SOURCE](#)
-  [Diodes Incorporated](#) Information

## Optimize Your Supply Chain with WIN SOURCE Solutions

-  Global Sourcing Solution
-  Obsolete Management
-  Cost Control Management
-  Shortage Management
-  Alternative Solution
-  Excess Inventory Management