



# THE DATASHEET OF ADUCM320BBCZ





# Precision Analog Microcontroller, 14-Bit Analog Input/Output with MDIO Interface, ARM Cortex-M3

Data Sheet

**ADuCM320**

## FEATURES

### Analog input/output

Multichannel, 14-bit, 1 MSPS analog-to-digital converter (ADC)

Up to 16 ADC input channels

0 V to VREF analog input range

Fully differential and single-ended modes

AV<sub>DD</sub> and IOV<sub>DD</sub> monitors

12-bit voltage output digital-to-analog converters (VDACs)

8 VDACs with a range of 0 V to 2.5 V or AV<sub>DD</sub> outputs

12-bit current output DACs (IDACs)

4 IDACs with a range of 0 mA to 150 mA outputs

Voltage comparator

### Microcontroller

ARM® Cortex®-M3 processor, 32-bit RISC architecture

Serial wire port supports code download and debug

### Clocking options

80 MHz phase-locked loop (PLL) with programmable divider

Trimmed on-chip oscillator ( $\pm 3\%$ )

External 16 MHz crystal option

External clock source up to 80 MHz

### Memory

2 × 128 kB independent Flash/EE memories

10,000 cycle Flash/EE endurance

20-year Flash/EE retention

32 kB SRAM

Software triggered in-circuit reprogrammability via management data input/output (MDIO)

### On-chip peripherals

MDIO slave up to 4 MHz

2 × I<sup>2</sup>C, 2 × SPI, UART

Multiple general-purpose input/output (GPIO) pins: 3.6 V compliant

7 × 1.2 V compatible when used for MDIO

32-element programmable logic array (PLA)

3 general-purpose timers

Wake-up timer

Watchdog timer

16-bit pulse width modulator (PWM)

### Power

Supply range: 2.9 V to 3.6 V, and 1.8 V to 2.5 V for IDACs

Flexible operating modes for low power applications

### Packages and temperature range

6 mm × 6mm, 96-ball CSP\_BGA package

Fully specified for -40°C to +105°C ambient operation

### Tools

Low cost QuickStart™ development system

Full third party support

## APPLICATIONS

Optical networking

Rev. D

[Document Feedback](#)

Information furnished by Analog Devices is believed to be accurate and reliable. However, no responsibility is assumed by Analog Devices for its use, nor for any infringements of patents or other rights of third parties that may result from its use. Specifications subject to change without notice. No license is granted by implication or otherwise under any patent or patent rights of Analog Devices. Trademarks and registered trademarks are the property of their respective owners.

One Technology Way, P.O. Box 9106, Norwood, MA 02062-9106, U.S.A.  
Tel: 781.329.4700 ©2014–2018 Analog Devices, Inc. All rights reserved.  
[Technical Support](#) [www.analog.com](http://www.analog.com)

## TABLE OF CONTENTS

Features .....	1	Absolute Maximum Ratings .....	21
Applications.....	1	ESD Caution.....	21
Revision History .....	2	Pin Configuration and Function Descriptions.....	22
Functional Block Diagram .....	3	Typical Performance Characteristics .....	27
General Description .....	4	Recommended Circuit and Component Values .....	28
Specifications.....	5	Packaging and Ordering Information .....	30
Microcontroller Electrical Specifications.....	5	Outline Dimensions.....	30
Timing Specifications .....	15	Ordering Guide .....	30

## REVISION HISTORY

### 5/2018—Rev. C to Rev. D

Change to Start-Up Time, At Power-On Parameter, Table 1.....	8
Change to Start-Up Time, At Power-On Parameter, Table 2....	13

### 10/2015—Rev. B to Rev. C

Change to Features Section .....	1
Added Table 2; Renumbered Sequentially .....	10
Changes to Table 7 and Figure 5.....	18
Changes to Table 8 and Figure 6.....	19
Change to Table 10 .....	21
Changes to Figure 14.....	27
Changes to Ordering Guide .....	30

### 3/2015—Rev. A to Rev. B

Changes to Table 1.....	7
Changes to $t_{SHD}$ and $t_{PSU}$ Parameters, Table 3 .....	10

### 11/2014—Rev. 0 to Rev. A

Changes to Figure 1.....	3
Changes to General Description .....	4
Changes to Table 1.....	5
Added Timing Specifications Section.....	10
Added Figure 2; Renumbered Sequentially .....	10
Added Figure 3.....	11
Added Figure 4.....	12
Added Figure 5.....	13
Added Figure 6 and Figure 7.....	14
Changes to Absolute Maximum Ratings Section.....	15
Changes to Pin C3 and Pin A11 Descriptions.....	17
Changes to Ordering Guide .....	24

### 6/2014—Revision 0: Initial Version

# FUNCTIONAL BLOCK DIAGRAM

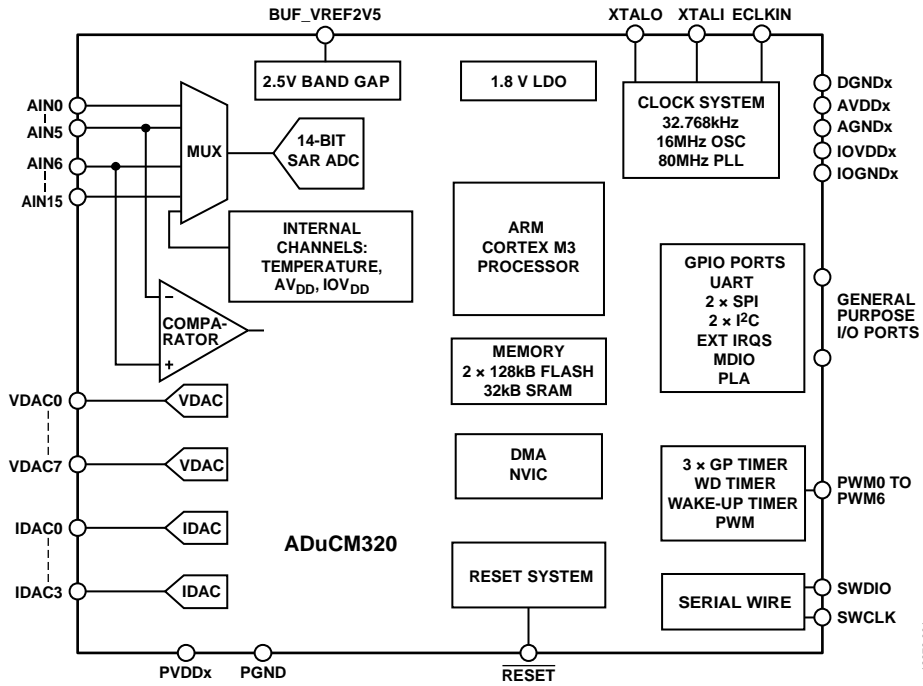

Figure 1.

12272-001

## GENERAL DESCRIPTION

The [ADuCM320](#) is a fully integrated single package device that incorporates high performance analog peripherals together with digital peripherals controlled by an 80 MHz ARM Cortex-M3 processor and integral flash for code and data.

The ADC on the [ADuCM320](#) provides 14-bit, 1 MSPS data acquisition on up to 16 input pins that can be programmed for single-ended or differential operation. The voltage at the IDAC output pins can also be measured by the ADC, which is useful for controlling the power consumption of the current DACs. Additionally, chip temperature and supply voltages can be measured.

The ADC input voltage is 0 V to VREF. A sequencer is provided, which allows a user to select a set of ADC channels to be measured in sequence without software involvement during the sequence. The sequence can optionally repeat automatically at a user selectable rate.

Up to eight VDACs are provided with output ranges that are programmable to one of two voltage ranges.

Four IDAC sources are provided. The output currents are programmable with ranges of 0 mA to 150 mA. A low drift band gap reference and voltage comparator completes the analog input peripheral set.

The [ADuCM320](#) can be configured so that the digital and analog outputs will retain their output voltages and currents through a watchdog or software reset sequence. Thus, a product can remain functional even while the [ADuCM320](#) is resetting itself.

The [ADuCM320](#) has a low power ARM Cortex-M3 processor and a 32-bit RISC machine that offers up to 100 MIPS peak performance. Also integrated on chip are  $2 \times 128$  kB Flash/EE memory and 32 kB of SRAM. The flash comprises two separate 128 kB blocks supporting execution from one flash block and simultaneous writing/erasing of the other flash block.

The [ADuCM320](#) operates from an on-chip oscillator or a 16 MHz external crystal and a PLL at 80 MHz. This clock can

optionally be divided down to reduce current consumption. Additional low power modes can be set via software. In normal operating mode, the [ADuCM320](#) digital core consumes about 300  $\mu$ A per MHz.

The device includes an MDIO interface capable of operating at up to 4 MHz. The capability to simultaneously execute from one flash block and write/erase the other flash block makes the [ADuCM320](#) ideal for 10G, 40G, and 100G optical applications. User programming is eased by incorporating PHYADR and DEVADD hardware comparators. In addition, the nonerasable kernel code plus flags in user flash provide assistance by allowing user code to robustly switch between the two blocks of user flash code and data spaces.

The [ADuCM320](#) integrates a range of on-chip peripherals that can be configured under software control, as required in the application. These peripherals include  $1 \times$  UART,  $2 \times$  I<sup>2</sup>C, and  $2 \times$  SPI serial input/output communication controllers, GPIO, 32-element programmable logic array, 3 general-purpose timers, plus a wake-up timer and system watchdog timer. A 16-bit PWM with seven output channels is also provided.

GPIO pins on the device power up in high impedance input mode. In output mode, the software chooses between open-drain mode and push-pull mode. The pull-up resistors can be disabled and enabled in software. In GPIO output mode, the inputs can remain enabled to monitor the pins. The GPIO pins can also be programmed to handle digital or analog peripheral signals, in which case the pin characteristics are matched to the specific requirement.

A large support ecosystem is available for the ARM Cortex-M3 processor to ease product development of the [ADuCM320](#). Access is via the ARM serial wire debug port (SW-DP). On-chip factory firmware supports in-circuit serial download via MDIO. These features are incorporated into a low cost QuickStart development system supporting this precision analog microcontroller family.

## SPECIFICATIONS

## MICROCONTROLLER ELECTRICAL SPECIFICATIONS

AVDD = IOVDD = VDD1 = 2.9 V to 3.6 V (see Figure 14) maximum difference between supplies = 0.3 V, VREF = 2.5 V internal reference,  $f_{\text{CORE}} = 80 \text{ MHz}$ ,  $T_A = -40^\circ\text{C}$  to  $+85^\circ\text{C}$ , unless otherwise noted. PVDDx for IDACs = 1.8 V to 2.5 V. Power-up sequence must be VDD1, IOVDDx, AVDDx, and then PVDDx, but no delays in the sequence are required.

Table 1.

Parameter	Symbol	Min	Typ	Max	Unit	Test Conditions/Comments
ADC BASIC SPECIFICATIONS						
ADC Power-Up Time			5		$\mu\text{s}$	Single-ended mode, unless otherwise stated
Data Rate	$f_{\text{SAMPLE}}$			1	MSPS	
DC Accuracy <sup>1</sup>		14			Bits	1 LSB = $2.5 \text{ V}/2^{14}$
Resolution <sup>1</sup>		16			Bits	Number of data bits
Integral Nonlinearity	INL		$\pm 1.75$		LSB	2.5 V internal reference; 1 LSB = $2.5 \text{ V}/2^{14}$
			$\pm 1.75$		LSB	2.5 V external reference; 1 LSB = $2.5 \text{ V}/2^{14}$
Differential Nonlinearity	DNL	-0.99	$\pm 0.75$	+1	LSB	2.5 V internal reference; 1 LSB = $2.5 \text{ V}/2^{14}$
			$\pm 0.75$		LSB	2.5 V external reference; 1 LSB = $2.5 \text{ V}/2^{14}$
DC Code Distribution			$\pm 3$		LSB	ADC input 1.25 V; 1 LSB = $2.5 \text{ V}/2^{14}$
ADC ENDPOINT ERRORS						
Offset Error					$\mu\text{V}$	
Input Buffer Off			$\pm 200$		$\mu\text{V}$	
Drift <sup>1</sup>		-2.25		+1.2	$\mu\text{V}/^\circ\text{C}$	Using 2.5 V external reference
Input Buffer On			-250		$\mu\text{V}$	
Drift <sup>1</sup>		-2.6		+2	$\mu\text{V}/^\circ\text{C}$	Using 2.5 V external reference
Match			$\pm 1$		LSB	Matching compared to AIN8
Full-Scale Error					$\mu\text{V}$	
Input Buffer Off			$\pm 400$		$\mu\text{V}$	
Gain Drift <sup>1</sup>		-4		+2	$\mu\text{V}/^\circ\text{C}$	Full-scale error drift minus offset error drift
Input Buffer On			-350		$\mu\text{V}$	
Gain Drift <sup>1</sup>		-4.5		+3	$\mu\text{V}/^\circ\text{C}$	Full-scale error drift minus offset error drift
Match			$\pm 1$		LSB	
ADC DYNAMIC PERFORMANCE						
Signal-to-Noise Ratio	SNR					$f_{\text{IN}} = 665.25 \text{ Hz}$ sine wave, $f_{\text{SAMPLE}} = 100 \text{ kSPS}$ ; input filter = $15 \Omega$ , $2 \text{ nF}$ Includes distortion and noise components
Input Buffer						
Disabled			80		dB	
Enabled			74		dB	
Total Harmonic Distortion	THD					
Input Buffer						
Disabled			-86		dB	
Enabled			-83		dB	
Peak Harmonic or Spurious Noise			-88		dB	
Channel-to-Channel Crosstalk			-90		dB	Measured on adjacent channels
ADC INPUT						
Input Voltage Ranges						Input buffer not enabled
Single-Ended Mode <sup>1</sup>		AGND4		VREF		
Differential Mode <sup>1</sup>		-VREF		+VREF	V	Voltage between differential pins
Compliance <sup>1</sup>		AGND4		AVDD4		
Common Mode <sup>1</sup>		0.9		1.6	V	

Parameter	Symbol	Min	Typ	Max	Unit	Test Conditions/Comments
Leakage Current AIN0 to AIN4, AIN6 to AIN15 AIN5			±1.5 ±20		nA nA	Pin shared with comparator
Input Current			±9 ±6 ±4		µA/V µA/V µA/V	At 1 MSPS; buffer off ≤800 kSPS; buffer off 500 kSPS; buffer off; ADCCNVC[25:16] = 0x1E
Input Capacitance			20		pF	During ADC acquisition
ADC INPUT BUFFER <sup>2</sup> Voltage Compliance <sup>1</sup> Input Current		0.15		2.5	V nA	When enabled by software Reduced accuracy below 0.15 V V <sub>IN</sub> = 0.15 V to 2.5 V, ADC converting
ON-CHIP VOLTAGE REFERENCE  Accuracy Reference Temperature Coefficient <sup>1</sup> Power Supply Rejection Ratio Internal V <sub>REF</sub> Power-On Time			2.51		V  mV ppm/°C dB ms	0.47 µF from VREF_1V2 to AGND4; reference is measured with all ADCs, VDACS, and IDACS enabled T <sub>A</sub> = 25°C
EXTERNAL REFERENCE INPUT Range <sup>1</sup> Input Current		1.8		2.5	V µA	ADC
BUFFERED REFERENCE OUTPUT Output Voltage Accuracy Reference Temperature Coefficient <sup>1</sup> Output Impedance Load Current <sup>1</sup>			2.504 ±8 -55 -5 10		V mV µV/°C Ω mA	T <sub>A</sub> = 25°C, load = 1.2 mA 100 nF from BUF_VREF2V5 to AGND4 T <sub>A</sub> = 25°C
VDAC CHANNEL SPECIFICATIONS DC Accuracy <sup>1</sup> Resolution <sup>1</sup> Relative Accuracy <sup>4</sup> Differential Nonlinearity <sup>4</sup>  Offset Error  Drift Gain Error <sup>5</sup>  Drift Mismatch Analog Outputs Output Voltage Range 1 <sup>1</sup> Output Voltage Range 2 <sup>1</sup> Output Impedance DAC AC Characteristics		12 12 -0.99		±4 +1	Bits Bits LSB LSB  mV  µV/°C % % ppm/°C % V V Ω	R <sub>L</sub> = 5 kΩ, C <sub>L</sub> = 100 pF <sup>3</sup> 1 LSB = 2.5 V/2 <sup>12</sup> Number of data bits 1 LSB = 2.5 V/2 <sup>12</sup> Guaranteed monotonic, 1 LSB = 2.5 V/2 <sup>12</sup> 2.5 V internal reference, DAC Output Code 0  0 V to internal V <sub>REF</sub> range 0 V to AVDD range Excluding reference drift % of full scale on DAC0
Output Settling Time Glitch Energy			10 ±20		µs nV-sec	Settled to ±1 LSB 1 LSB change when the maximum number of bits changes simultaneously in the DACxDAT register
IDAC CHANNEL SPECIFICATIONS Resolution <sup>1</sup> Full-Scale Output <sup>1</sup> Supply Voltage Each Channel <sup>1</sup>  Output Compliance Range IDAC0, IDAC1 IDAC2, IDAC3		14 1.8 0.4 0.4	150	2.5	Bits mA V V V	Combination of overlapping 11 bits and 5 bits  Separate PVDDx supply for each channel  See Figure 11 See Figure 11

Parameter	Symbol	Min	Typ	Max	Unit	Test Conditions/Comments
Full-Scale Error						IDAC set to 85% of full scale
IDAC0, IDAC1				±0.75	%	25°C to 105°C range
IDAC2, IDAC3				±3.5	%	–40°C to +105°C range
Full-Scale Error Drift				±0.75	%	–40°C to +105°C range
IDAC0, IDAC1						Internal V <sub>REF</sub>
–40°C to +85°C			25		µA/°C	
25°C to 85°C			5		µA/°C	
IDAC2, IDAC3			2		µA/°C	Internal V <sub>REF</sub>
Integral Nonlinearity	INL		±3	±6	LSB	1 LSB = 150 mA/2 <sup>11</sup>
Differential Nonlinearity	DNL	–0.99		+1.5	LSB	Guaranteed 11-bit monotonic, 1 LSB = 150 mA/2 <sup>11</sup>
Zero-Scale Error			±50		µA	
Zero-Scale Error Drift						
IDAC0, IDAC1			±300		nA/°C	
IDAC2, IDAC3			±800		nA/°C	
Noise Current			2		µA	IDACxCON[5:2] = 0
Pull-Down Current		–220	–165	–100	µA	When enabled
Settling Time						IDACxCON[5:2] = 0
To 0.1%			100		µs	±4 mA change from midscale
To 1%			50		µs	±4 mA change from midscale
Full Scale to 0 mA			20		µs	Pull-down enabled
Overheat Shutdown			135		°C	Junction temperature
PVDD ACPSRR						IDACxCON[5:2] = 0
100 Hz			51		dB	
1 kHz			45		dB	
10 kHz			25		dB	
100 kHz			10		dB	
COMPARATOR						
Input						
Offset Voltage			±10		mV	
Bias Current			1		nA	
Voltage Range <sup>1</sup>		AGNDx		AVDDx – 1.2	V	
Capacitance			7		pF	
Hysteresis <sup>1</sup>		8.5		15	mV	When enabled in software
Response Time			7		µs	AFECOMP[2:1] = 0
TEMPERATURE SENSOR						
Resolution			0.5		°C	Indicates die temperature, see Figure 9
Accuracy <sup>1</sup>		1.34		1.43	V	When precision calibrated by the user <sup>6</sup> ADC measured voltage for temperature sensor channel without calibration, T = 25°C
POWER-ON RESET	POR		2.85	2.9	V	
External Reset Minimum Pulse Width <sup>1</sup>		1.5			µs	Minimum pulse width required on external reset pin to trigger a reset sequence
WATCHDOG TIMER	WDT					
Timeout Period			32		sec	Default at power-up
FLASH/EE MEMORY						
Endurance <sup>1</sup>		10,000			Cycles	
Data Retention <sup>1</sup>		20			Years	T <sub>J</sub> = 85°C

Parameter	Symbol	Min	Typ	Max	Unit	Test Conditions/Comments
<b>DIGITAL INPUTS</b>						
Input Leakage Current						
Logic 1 GPIO			1		nA	$V_{IH} = V_{DD}$ , pull-up resistor disabled
Logic 0 GPIO			10		nA	$V_{IL} = 0\text{ V}$ , pull-up resistor disabled
<b>PRTADDRx</b>						
Input Leakage Current			16		$\mu\text{A}$	$V_{IN} = 0$ to 1.8 V, due to weak pull-up resistors to 1.8 V
Input Voltage		0.84		1.5	V	External resistor $91\text{ k}\Omega \pm 1\%$ to ground, range for CFP MSA high <sup>1</sup>
Input Capacitance, All Pins Except MCK, MDIO, PRTADDRx, and XTALx			10		pF	
<b>Input Capacitance</b>						
MCK, PRTADDRx			6.5		pF	
MDIO			8.5		pF	
<b>Pin Capacitance</b>						
XTALI			5		pF	
XTALO			5		pF	
<b>LOGIC INPUTS</b>						
<b>GPIO Input Voltage</b>						
Low	$V_{INL}$			$0.25 \times IOVDDx$	V	
High	$V_{INH}$	$0.58 \times IOVDDx$			V	
<b>MDIO</b>						
<b>PRTADDRx Input Voltage</b>						
Low	$V_{INL}$			0.36	V	
High	$V_{INH}$	0.84			V	
<b>MCK, MDIO Input Voltage</b>						
Low	$V_{INL}$			0.36	V	
High	$V_{INH}$	0.84			V	
<b>XTALI Input Voltage</b>						
Low	$V_{INL}$		1.1		V	
High	$V_{INH}$		1.7		V	
Pull-Up Current		30		120	$\mu\text{A}$	$V_{IN} = 0\text{ V}$ , see Figure 10
Pull-Down Current		30		100	$\mu\text{A}$	$V_{IN} = 3.3\text{ V}$ , see Figure 10
<b>LOGIC OUTPUTS</b>						
<b>GPIO Output Voltage<sup>7</sup></b>						
High	$V_{OH}$	$IOVDDx - 0.4$			V	$I_{SOURCE} = 2\text{ mA}$
Low	$V_{OL}$			0.4	V	$I_{SINK} = 2\text{ mA}$
GPIO Short-Circuit Current <sup>1</sup>			11		$\text{mA}$	See Figure 13
<b>MDIO</b>						
<b>Output Voltage</b>						
High	$V_{OH}$	1.0			V	$I_{SOURCE} = 4\text{ mA}$
Low	$V_{OL}$			0.2	V	$I_{SINK} = 4\text{ mA}$
Delay Time				100	ns	MCK to MDIO out
<b>OSCILLATORS</b>						
<b>Internal System Oscillator</b>						
Accuracy			$\pm 0.5$	$\pm 3$	MHz %	
System PLL			80		MHz	Main system clock
<b>External Crystal Oscillator</b>						
			16		MHz	Can be selected in place of internal oscillator
<b>32 kHz Internal Oscillator</b>						
Accuracy			32.768		kHz %	Use for watchdog
Accuracy			$\pm 5$	$\pm 20$	%	
External Clock		0.05		80	MHz	Can be selected in place of PLL
<b>START-UP TIME</b>						
At Power-On			50		ms	Processor clock = 80 MHz
After Other Reset			1.5		ms	POR to first user code execution
From All Power-Down Modes			1.25		$\mu\text{s}$	Reset to first user code execution

Parameter	Symbol	Min	Typ	Max	Unit	Test Conditions/Comments
PROGRAMMABLE LOGIC ARRAY	PLA					
Propagation Delay			17		ns	From input pin to output pin
Pin Element			1.5		ns	Per PLA cell
EXTERNAL INTERRUPTS						
Pulse Width <sup>1</sup>						
Level Triggered		7			ns	
Edge Triggered		1			ns	
POWER REQUIREMENTS <sup>8</sup>						
Power Supply Voltage Range						
AVDDx to AGNDx and IOVDDx to DGNDx <sup>1</sup>		2.9	3.3	3.6	V	
Analog Power Supply Currents						
AVDDx Current			6.3		mA	Analog peripherals in idle mode
Digital Power Supply Current						
IOVDDx Current in Normal Mode			4		mA	All GPIO pull-up resistors enabled
VDDx Current						
Normal Mode <sup>9</sup>			29		mA	CD = 0 (80 MHz clock) executing typical code
			20		mA	CD = 1 executing typical code
			10		mA	CD = 7 executing typical code
CORE_SLEEP Mode <sup>9</sup>			16		mA	
SYS_SLEEP Mode <sup>9</sup>			8		mA	
Hibernate Mode <sup>9</sup>			6.6		mA	
Additional Power Supply Currents						
ADC			4.1		mA	Continuously converting at 100 kSPS
ADC Input Buffer			4.0		mA	Both buffers enabled
IDAC			16.5		mA	Excluding load current
DAC			340		μA	Per powered up DAC, excluding load current
Total Supply Current		35	40	45	mA	VDD1, IOVDDx, AVDDx connected together; condition when entering user code: peripheral clocks on, peripherals idle, no load currents
Thermal Performance						
Impedance Junction-to-Ambient			45		°C/W	JEDEC 2S2P

<sup>1</sup> These numbers are not production tested but are guaranteed by design and/or characterization data at production release.

<sup>2</sup> Enabling the input buffer changes the ADC input characteristics as described in this subsection.

<sup>3</sup> The data in this section also applies for a load of  $R_L = 1 \text{ k}\Omega$  and  $C_L = 100 \text{ pF}$  to GND but only for 0 V to 2.5 V. However, this is not production tested.

<sup>4</sup> DAC linearity is calculated using a reduced code range of 100 to 3900.

<sup>5</sup> DAC gain error is calculated using a reduced code range of 100 to an internal  $2.5 \text{ V } V_{REF}$ .

<sup>6</sup> Due to self heating, internal temperature measurements cannot be used to predict external temperatures. This value is only relevant after user calibration and only for internal and external conditions identical to those at calibration.

<sup>7</sup> The average current from all GPIO pins must not exceed 3 mA per pin.

<sup>8</sup> Power figures exclude any load currents to external circuits.

<sup>9</sup> See the ADuCM320 reference manual, [How to Set up and Use the ADuCM320](#).

AVDD = IOVDD = VDD1 = 2.9 V to 3.6 V maximum difference between supplies = 0.3 V, VREF = 2.5 V internal reference,  $f_{\text{CORE}} = 80$  MHz,  $T_A = -40^\circ\text{C}$  to  $+105^\circ\text{C}$ , unless otherwise noted. PVDDx for IDACs = 1.8 V to 2.5 V. Power-up sequence must be VDD1, IOVDDx, AVDDx, and then PVDDx, but no delays in the sequence are required.

Table 2.

Parameter	Symbol	Min	Typ	Max	Unit	Test Conditions/Comments
ADC BASIC SPECIFICATIONS						
ADC Power-Up Time			5		$\mu\text{s}$	Single-ended mode, unless otherwise stated
Data Rate	$f_{\text{SAMPLE}}$			1	MSPS	
DC Accuracy <sup>1</sup>		14			Bits	1 LSB = $2.5 \text{ V}/2^{14}$
Resolution <sup>1</sup>		16			Bits	Number of data bits
Integral Nonlinearity	INL		$\pm 1.75$		LSB	2.5 V internal reference; 1 LSB = $2.5 \text{ V}/2^{14}$
			$\pm 1.75$		LSB	2.5 V external reference; 1 LSB = $2.5 \text{ V}/2^{14}$
Differential Nonlinearity	DNL	-0.99	$\pm 0.75$	+1.5	LSB	2.5 V internal reference; 1 LSB = $2.5 \text{ V}/2^{14}$
			$\pm 0.75$		LSB	2.5 V external reference; 1 LSB = $2.5 \text{ V}/2^{14}$
DC Code Distribution			$\pm 3$		LSB	ADC input 1.25 V; 1 LSB = $2.5 \text{ V}/2^{14}$
ADC ENDPOINT ERRORS						
Offset Error					$\mu\text{V}$	Using 2.5 V external reference
Input Buffer Off			$\pm 200$		$\mu\text{V}/^\circ\text{C}$	
Drift <sup>1</sup>		-2.25		+1.2	$\mu\text{V}$	Using 2.5 V external reference
Input Buffer On			-250		$\mu\text{V}/^\circ\text{C}$	
Drift <sup>1</sup>		-3		+2	$\mu\text{V}/^\circ\text{C}$	Matching compared to AIN8
Match			$\pm 1$		LSB	
Full-Scale Error					$\mu\text{V}$	Full-scale error drift minus offset error drift
Input Buffer Off			$\pm 400$		$\mu\text{V}/^\circ\text{C}$	
Gain Drift <sup>1</sup>		-4.3		+2	$\mu\text{V}/^\circ\text{C}$	Full-scale error drift minus offset error drift
Input Buffer On			-350		$\mu\text{V}/^\circ\text{C}$	
Gain Drift <sup>1</sup>		-4.5		+3	$\mu\text{V}/^\circ\text{C}$	Full-scale error drift minus offset error drift
Match			$\pm 1$		LSB	
ADC DYNAMIC PERFORMANCE						
Signal-to-Noise Ratio	SNR					$f_{\text{IN}} = 665.25$ Hz sine wave, $f_{\text{SAMPLE}} = 100$ kSPS; input filter = $15 \Omega$ , $2 \text{ nF}$ Includes distortion and noise components
Input Buffer						
Disabled			80		dB	Measured on adjacent channels
Enabled			74		dB	
Total Harmonic Distortion	THD					Measured on adjacent channels
Input Buffer						
Disabled			-86		dB	Measured on adjacent channels
Enabled			-83		dB	
Peak Harmonic or Spurious Noise			-88		dB	Measured on adjacent channels
Channel-to-Channel Crosstalk			-90		dB	
ADC INPUT						
Input Voltage Ranges						Input buffer not enabled
Single-Ended Mode <sup>1</sup>		AGND4		VREF		Voltage between differential pins
Differential Mode <sup>1</sup>		-VREF		+VREF	V	
Compliance <sup>1</sup>		AGND4		AVDD4	V	
Common Mode <sup>1</sup>		0.9		1.6	V	

Parameter	Symbol	Min	Typ	Max	Unit	Test Conditions/Comments
Leakage Current AIN0 to AIN4, AIN6 to AIN15 AIN5			±1.5 ±20		nA nA	Pin shared with comparator At 1 MSPS; buffer off ≤800 kSPS; buffer off 500 kSPS; buffer off; ADCCNVC[25:16] = 0x1E During ADC acquisition
Input Current			±9 ±6 ±4		µA/V µA/V µA/V	
Input Capacitance			20		pF	
ADC INPUT BUFFER <sup>2</sup> Voltage Compliance <sup>1</sup> Input Current		0.15		2.5	V nA	
ON-CHIP VOLTAGE REFERENCE  Accuracy Reference Temperature Coefficient <sup>1</sup> Power Supply Rejection Ratio Internal V <sub>REF</sub> Power-On Time			2.51		V	0.47 µF from VREF_1V2 to AGND4; reference is measured with all ADCs, VDACs, and IDACs enabled T <sub>A</sub> = 25°C
				±5	mV	
		-34	-15	+4	ppm/°C	
	PSRR		60		dB	
			50		ms	
EXTERNAL REFERENCE INPUT Range <sup>1</sup> Input Current		1.8		2.5	V µA	ADC
BUFFERED REFERENCE OUTPUT Output Voltage Accuracy Reference Temperature Coefficient <sup>1</sup>  Output Impedance Load Current <sup>1</sup>			2.504 ±8		V mV µV/°C	T <sub>A</sub> = 25°C, load = 1.2 mA 100 nF from BUF_VREF2V5 to AGND4 T <sub>A</sub> = 25°C
		-55	-5	+40		
			10	1.2	Ω mA	
VDAC CHANNEL SPECIFICATIONS DC Accuracy <sup>1</sup> Resolution <sup>1</sup> Relative Accuracy <sup>4</sup> Differential Nonlinearity <sup>4</sup>  Offset Error  Drift Gain Error <sup>5</sup>  Drift Mismatch Analog Outputs Output Voltage Range 1 <sup>1</sup> Output Voltage Range 2 <sup>1</sup> Output Impedance DAC AC Characteristics Output Settling Time Glitch Energy						R <sub>L</sub> = 5 kΩ, C <sub>L</sub> = 100 pF <sup>3</sup> 1 LSB = 2.5 V/2 <sup>12</sup> Number of data bits 1 LSB = 2.5 V/2 <sup>12</sup> Guaranteed monotonic, 1 LSB = 2.5 V/2 <sup>12</sup> 2.5 V internal reference, DAC Output Code 0  0 V to internal V <sub>REF</sub> range 0 V to AVDD range Excluding reference drift % of full scale on DAC0
		12			Bits	
		12			Bits	
	INL		±4		LSB	
	DNL	-0.99		+1	LSB	
			±3	±15	mV	
			±13		µV/°C	
			±0.3	±0.85	%	
			±0.4	±1	%	
			6.5		ppm/°C	
			0.1		%	
		0.15		2.5	V	
		0.15		AVDDx - 0.15	V	
			2		Ω	
			10		µs	
			±20		nV-sec	
IDAC CHANNEL SPECIFICATIONS Resolution <sup>1</sup>  Full-Scale Output <sup>1</sup> Supply Voltage Each Channel <sup>1</sup>  Output Compliance Range IDAC0, IDAC1 IDAC2, IDAC3						Combination of overlapping 11 bits and 5 bits  Separate PVDDx supply for each channel  See Figure 11 See Figure 11
		14			Bits	
			150		mA	
		1.8		2.5	V	
		0.4		PVDDx - 400 mV	V	
		0.4		PVDDx - 250 mV	V	

Parameter	Symbol	Min	Typ	Max	Unit	Test Conditions/Comments
Full-Scale Error						IDAC set to 85% of full scale
IDAC0, IDAC1				±0.75	%	25°C to 105°C range
IDAC2, IDAC3				±3.5	%	
IDAC2, IDAC3				±0.75	%	
Full-Scale Error Drift						Internal V <sub>REF</sub>
IDAC0, IDAC1			25		µA/°C	
–40°C to 105°C			5		µA/°C	
25°C to 105°C			2		µA/°C	
IDAC2, IDAC3			2		µA/°C	Internal V <sub>REF</sub>
Integral Nonlinearity	INL		±3	±6	LSB	1 LSB = 150 mA/2 <sup>11</sup>
Differential Nonlinearity	DNL	–0.99		+1.5	LSB	Guaranteed 11-bit monotonic, 1 LSB = 150 mA/2 <sup>11</sup>
Zero-Scale Error			±50		µA	
Zero-Scale Error Drift						
IDAC0, IDAC1			±300		nA/°C	
IDAC2, IDAC3			±800		nA/°C	
Noise Current			2		µA	IDACxCON[5:2] = 0
Pull-Down Current		–220	–165	–100	µA	When enabled
Settling Time						IDACxCON[5:2] = 0
To 0.1%			100		µs	±4 mA change from midscale
To 1%			50		µs	±4 mA change from midscale
Full Scale to 0 mA			20		µs	Pull-down enabled
Overheat Shutdown			135		°C	Junction temperature
PVDD ACPSRR						IDACxCON[5:2] = 0
100 Hz			51		dB	
1 kHz			45		dB	
10 kHz			25		dB	
100 kHz			10		dB	
COMPARATOR						
Input						
Offset Voltage			±10		mV	
Bias Current			1		nA	
Voltage Range <sup>1</sup>		AGNDx		AVDDx – 1.2	V	
Capacitance			7		pF	
Hysteresis <sup>1</sup>		8.5		15	mV	When enabled in software
Response Time			7		µs	AFECOMP[2:1] = 0
TEMPERATURE SENSOR						
Resolution			0.5		°C	Indicates die temperature, see Figure 9
Accuracy <sup>1</sup>		1.34		1.43	V	When precision calibrated by the user <sup>6</sup>
						ADC measured voltage for temperature sensor channel without calibration, T = 25°C
POWER-ON RESET	POR		2.85	2.9	V	
External Reset Minimum Pulse Width <sup>1</sup>		1.5			µs	Minimum pulse width required on external reset pin to trigger a reset sequence
WATCHDOG TIMER	WDT					
Timeout Period			32		sec	Default at power-up
FLASH/EE MEMORY						
Endurance <sup>1</sup>		10,000			Cycles	
Data Retention <sup>1</sup>		20			Years	T <sub>J</sub> = 85°C

Parameter	Symbol	Min	Typ	Max	Unit	Test Conditions/Comments
<b>DIGITAL INPUTS</b>						
Input Leakage Current						
Logic 1 GPIO			1		nA	$V_{IH} = V_{DD}$ , pull-up resistor disabled
Logic 0 GPIO			10		nA	$V_{IL} = 0\text{ V}$ , pull-up resistor disabled
<b>PRTADDRx</b>						
Input Leakage Current			16		$\mu\text{A}$	$V_{IN} = 0$ to 1.8 V, due to weak pull-up resistors to 1.8 V
Input Voltage		0.84		1.5	V	External resistor $91\text{ k}\Omega \pm 1\%$ to ground, range for CFP MSA high <sup>1</sup>
Input Capacitance, All Pins Except MCK, MDIO, PRTADDRx, and XTALx			10		pF	
<b>Input Capacitance</b>						
MCK, PRTADDRx			6.5		pF	
MDIO			8.5		pF	
<b>Pin Capacitance</b>						
XTALI			5		pF	
XTALO			5		pF	
<b>LOGIC INPUTS</b>						
<b>GPIO Input Voltage</b>						
Low	$V_{INL}$			$0.25 \times IOVDDx$	V	
High	$V_{INH}$	$0.58 \times IOVDDx$			V	
<b>MDIO</b>						
<b>PRTADDRx Input Voltage</b>						
Low	$V_{INL}$			0.36	V	
High	$V_{INH}$	0.84			V	
<b>MCK, MDIO Input Voltage</b>						
Low	$V_{INL}$			0.36	V	
High	$V_{INH}$	0.84			V	
<b>XTALI Input Voltage</b>						
Low	$V_{INL}$		1.1		V	
High	$V_{INH}$		1.7		V	
Pull-Up Current		30		120	$\mu\text{A}$	$V_{IN} = 0\text{ V}$ , see Figure 10
Pull-Down Current		30		100	$\mu\text{A}$	$V_{IN} = 3.3\text{ V}$ , see Figure 10
<b>LOGIC OUTPUTS</b>						
<b>GPIO Output Voltage<sup>7</sup></b>						
High	$V_{OH}$	$IOVDDx - 0.4$			V	
Low	$V_{OL}$			0.4	V	
GPIO Short-Circuit Current <sup>1</sup>			11		mA	See Figure 13
<b>MDIO</b>						
<b>Output Voltage</b>						
High	$V_{OH}$	1.0			V	$I_{SOURCE} = 4\text{ mA}$
Low	$V_{OL}$			0.2	V	$I_{SINK} = 4\text{ mA}$
Delay Time				100	ns	MCK to MDIO out
<b>OSCILLATORS</b>						
<b>Internal System Oscillator</b>						
Accuracy			$\pm 0.5$	$\pm 3$	MHz %	
System PLL			80		MHz	Main system clock
<b>External Crystal Oscillator</b>						
			16		MHz	Can be selected in place of internal oscillator
<b>32 kHz Internal Oscillator</b>						
Accuracy			$\pm 5$	$\pm 20$	kHz %	Use for watchdog
<b>External Clock</b>						
		0.05		80	MHz	Can be selected in place of PLL
<b>START-UP TIME</b>						
At Power-On			50		ms	Processor clock = 80 MHz
After Other Reset			1.5		ms	POR to first user code execution
From All Power-Down Modes			1.25		$\mu\text{s}$	Reset to first user code execution

Parameter	Symbol	Min	Typ	Max	Unit	Test Conditions/Comments
PROGRAMMABLE LOGIC ARRAY	PLA					
Propagation Delay			17		ns	From input pin to output pin
Pin Element			1.5		ns	Per PLA cell
EXTERNAL INTERRUPTS						
Pulse Width <sup>1</sup>						
Level Triggered		7			ns	
Edge Triggered		1			ns	
POWER REQUIREMENTS <sup>8</sup>						
Power Supply Voltage Range		2.9	3.3	3.6	V	
AVDDx to AGNDx and IOVDDx to DGNDx <sup>1</sup>						
Analog Power Supply Currents			6.3		mA	Analog peripherals in idle mode
AVDDx Current						
Digital Power Supply Current			4		mA	All GPIO pull-up resistors enabled
IOVDDx Current in Normal Mode						
VDDx Current			29		mA	CD = 0 (80 MHz clock) executing typical code
Normal Mode <sup>9</sup>			20		mA	CD = 1 executing typical code
CORE_SLEEP Mode <sup>9</sup>			10		mA	CD = 7 executing typical code
SYS_SLEEP Mode <sup>9</sup>			16		mA	
Hibernate Mode <sup>9</sup>			8		mA	
Additional Power Supply Currents						
ADC			4.1		mA	Continuously converting at 100 kSPS
ADC Input Buffer			4.0		mA	Both buffers enabled
IDAC			16.5		mA	Excluding load current
DAC			340		μA	Per powered up DAC, excluding load current
Total Supply Current		35	40	45	mA	VDD1, IOVDDx, AVDDx connected together; condition when entering user code: peripheral clocks on, peripherals idle, no load currents
Thermal Performance			45		°C/W	JEDEC 2S2P
Impedance Junction-to-Ambient						

<sup>1</sup> These numbers are not production tested but are guaranteed by design and/or characterization data at production release.

<sup>2</sup> Enabling the input buffer changes the ADC input characteristics as described in this subsection.

<sup>3</sup> The data in this section also applies for a load of  $R_L = 1 \text{ k}\Omega$  and  $C_L = 100 \text{ pF}$  to GND but only for 0 V to 2.5 V. However, this is not production tested.

<sup>4</sup> DAC linearity is calculated using a reduced code range of 100 to 3900.

<sup>5</sup> DAC gain error is calculated using a reduced code range of 100 to an internal 2.5 V  $V_{REF}$ .

<sup>6</sup> Due to self heating, internal temperature measurements cannot be used to predict external temperatures. This value is only relevant after user calibration and only for internal and external conditions identical to those at calibration.

<sup>7</sup> The average current from all GPIO pins must not exceed 3 mA per pin.

<sup>8</sup> Power figures exclude any load currents to external circuits.

<sup>9</sup> See the ADuCM320 reference manual, [How to Set up and Use the ADuCM320](#).

**TIMING SPECIFICATIONS**

**I<sup>2</sup>C Timing**

**Table 3. I<sup>2</sup>C Timing in Standard Mode (100 kHz)**

Parameter	Description	Slave			Unit
		Min	Typ	Max	
t <sub>L</sub>	SCL low pulse width	4.7			μs
t <sub>H</sub>	SCL high pulse width	4.0			ns
t <sub>SHD</sub>	Start condition hold time	4.0			μs
t <sub>DSU</sub>	Data setup time	250			ns
t <sub>DHD</sub>	Data hold time (SDA held internally for 300 ns after falling edge of SCL)	0		3.45	μs
t <sub>RSU</sub>	Setup time for repeated start	4.7			μs
t <sub>PSU</sub>	Stop condition setup time	4.0			μs
t <sub>BUF</sub>	Bus-free time between a stop condition and a start condition	4.7			μs
t <sub>R</sub>	Rise time for both SLC and SDA			1	μs
t <sub>F</sub>	Fall time for both SLC and SDA		15	300	ns
t <sub>VD;DAT</sub>	Data valid time			3.45	μs
t <sub>VD;ACK</sub>	Data valid acknowledge time			3.45	μs

**Table 4. I<sup>2</sup>C Timing in Fast Mode (400 kHz)**

Parameter	Description	Slave			Unit
		Min	Typ	Max	
t <sub>L</sub>	SCL low pulse width	1.3			μs
t <sub>H</sub>	SCL high pulse width	0.6			ns
t <sub>SHD</sub>	Start condition hold time	0.3			μs
t <sub>DSU</sub>	Data setup time	100			ns
t <sub>DHD</sub>	Data hold time (SDA held internally for 300 ns after falling edge of SCL)	0			μs
t <sub>RSU</sub>	Setup time for repeated start	0.6			μs
t <sub>PSU</sub>	Stop condition setup time	0.3			μs
t <sub>BUF</sub>	Bus-free time between a stop condition and a start condition	1.3			μs
t <sub>R</sub>	Rise time for both SCL and SDA	20		300	ns
t <sub>F</sub>	Fall time for both SCL and SDA		15	300	ns
t <sub>VD;DAT</sub>	Data valid time			0.9	μs
t <sub>VD;ACK</sub>	Data valid acknowledge time			0.9	μs

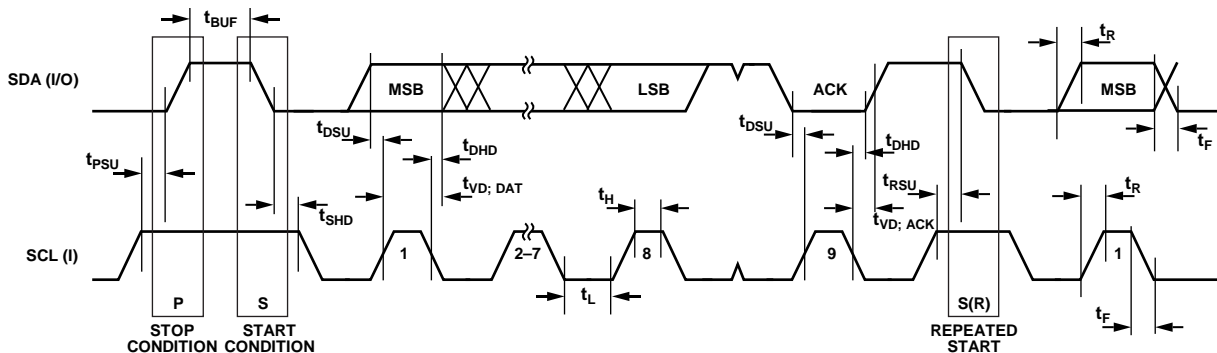

Figure 2. I<sup>2</sup>C Compatible Interface Timing

12272-002

SPI Timing

Table 5. SPI Master Mode Timing (Phase Mode = 1)

Parameter	Description	Min	Typ	Max	Unit
$t_{SL}$	SCLK low pulse width		$(SPIDIV + 1) \times t_{HCLK}/2$		ns
$t_{SH}$	SCLK high pulse width		$(SPIDIV + 1) \times t_{HCLK}/2$		ns
$t_{DAV}$	Data output valid after SCLK edge	0	3		ns
$t_{DSU}$	Data input setup time before SCLK edge		$\frac{1}{2}$ SCLK		ns
$t_{DHD}$	Data input hold time after SCLK edge		SCLK		ns
$t_{DF}$	Data output fall time		SCLK		ns
$t_{DR}$	Data output rise time		25		ns
$t_{SR}$	SCLK rise time		25		ns
$t_{SF}$	SCLK fall time		20		ns

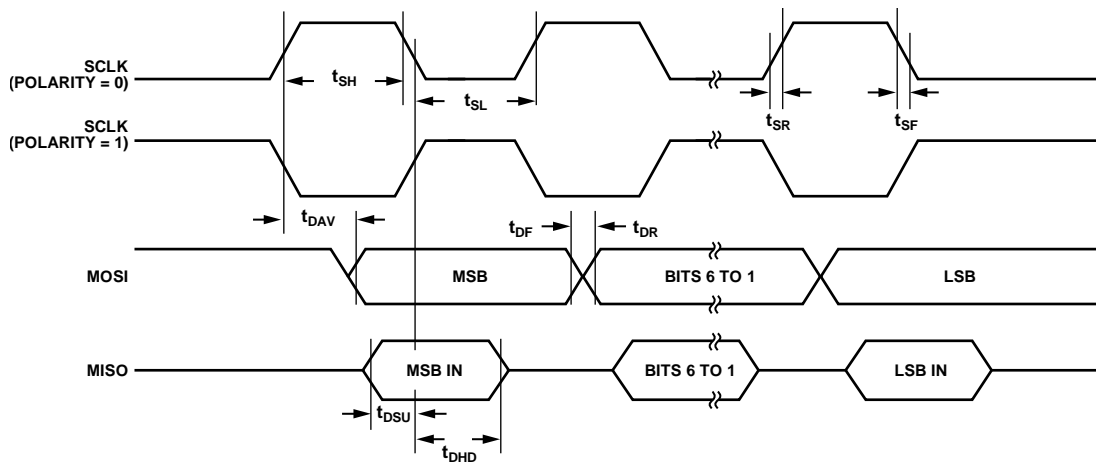

Figure 3. SPI Master Mode Timing (Phase Mode = 1)

12727-003

Table 6. SPI Master Mode Timing (Phase Mode = 0)

Parameter	Description	Min	Typ	Max	Unit
$t_{SL}$	SCLK low pulse width		$(SPIDIV + 1) \times t_{HCLK}/2$		ns
$t_{SH}$	SCLK high pulse width		$(SPIDIV + 1) \times t_{HCLK}/2$		ns
$t_{DAV}$	Data output valid after SCLK edge	0	3		ns
$t_{DOSU}$	Data output setup before SCLK edge		$\frac{1}{2}$ SCLK		ns
$t_{DSU}$	Data input setup time before SCLK edge		SCLK		ns
$t_{DHD}$	Data input hold time after SCLK edge		SCLK		ns
$t_{DF}$	Data output fall time		25		ns
$t_{DR}$	Data output rise time		25		ns
$t_{SR}$	SCLK rise time		20		ns
$t_{SF}$	SCLK fall time		20		ns

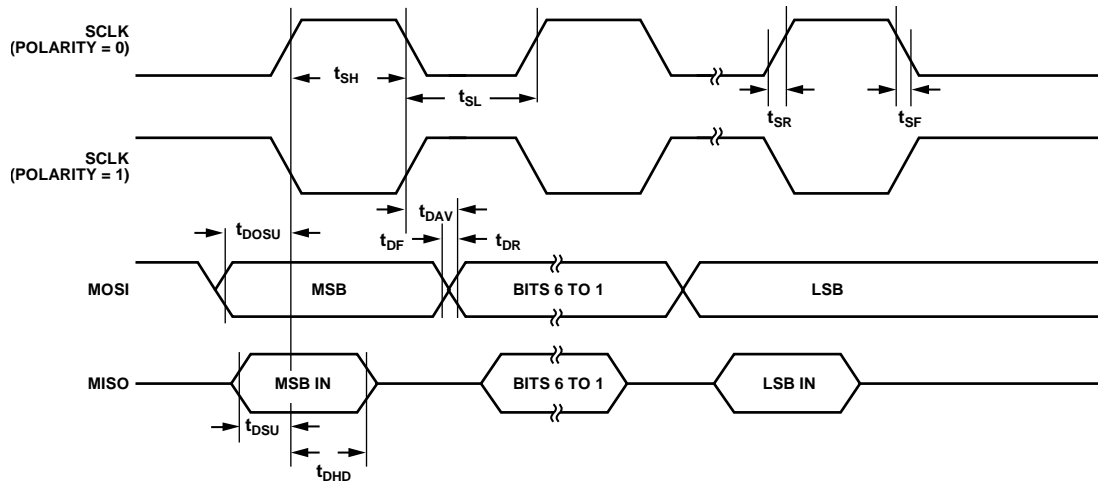

Figure 4. SPI Master Mode Timing (Phase Mode = 0)

12272-004

Table 7. SPI Slave Mode Timing (Phase Mode = 1)

Parameter	Description	Min	Typ	Max	Unit
$t_{\overline{CS}}$	$\overline{CS}$ to SCLK edge	10			ns
$t_{\overline{CSM}}$	$\overline{CS}$ high time between active periods	SCLKx			ns
$t_{SL}$	SCLK low pulse width		$(SPIDIV + 1) \times t_{HCLK}$		ns
$t_{SH}$	SCLK high pulse width		$(SPIDIV + 1) \times t_{HCLK}$		ns
$t_{DAV}$	Data output valid after SCLK edge		20		ns
$t_{DSU}$	Data input setup time before SCLK edge	10			ns
$t_{DHD}$	Data input hold time after SCLK edge	10			ns
$t_{DF}$	Data output fall time		25		ns
$t_{DR}$	Data output rise time		25		ns
$t_{SR}$	SCLK rise time	1			ns
$t_{SF}$	SCLK fall time	1			ns
$t_{SFS}$	$\overline{CS}$ high after SCLK edge	20			ns

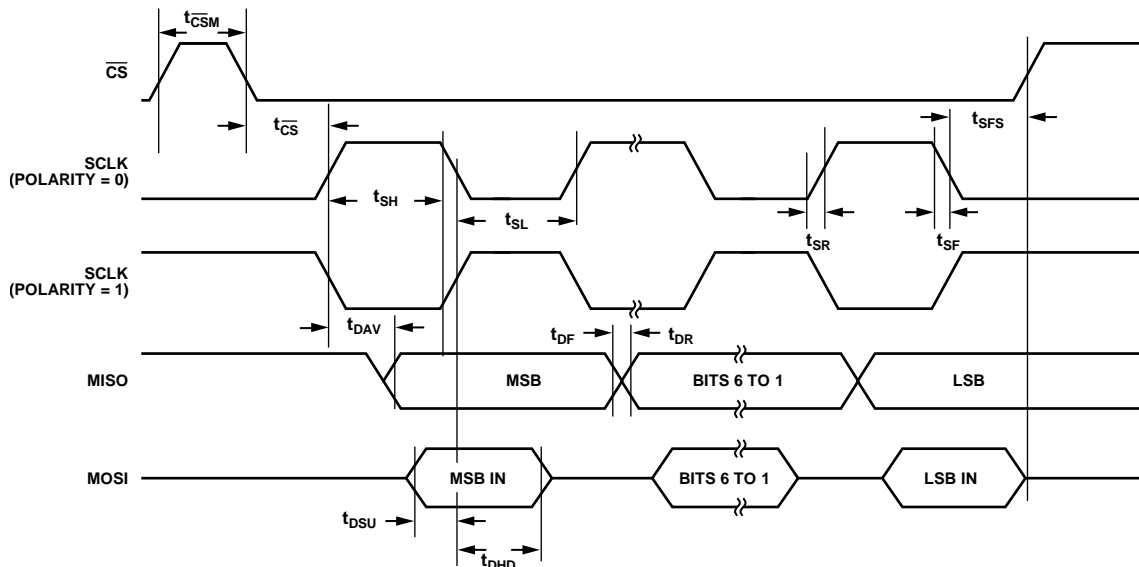

Figure 5. SPI Slave Mode Timing (Phase Mode = 1)

12272-005

Table 8. SPI Slave Mode Timing (Phase Mode = 0)

Parameter	Description	Min	Typ	Max	Unit
$t_{\overline{CS}}$	$\overline{CS}$ to SCLK edge	10			ns
$t_{\overline{CSM}}$	$\overline{CS}$ high time between active periods	SCLKx			ns
$t_{SL}$	SCLK low pulse width		$(SPIDIV + 1) \times t_{HCLK}$		ns
$t_{SH}$	SCLK high pulse width		$(SPIDIV + 1) \times t_{HCLK}$		ns
$t_{DAV}$	Data output valid after SCLK edge		20		ns
$t_{DSU}$	Data input setup time before SCLK edge	10			ns
$t_{DHD}$	Data input hold time after SCLK edge	10			ns
$t_{DF}$	Data output fall time		25		ns
$t_{DR}$	Data output rise time		25		ns
$t_{SR}$	SCLK rise time	1			ns
$t_{SF}$	SCLK fall time	1			ns
$t_{DOCS}$	Data output valid after $\overline{CS}$ edge	20			ns
$t_{SFS}$	$\overline{CS}$ high after SCLK edge	10			ns

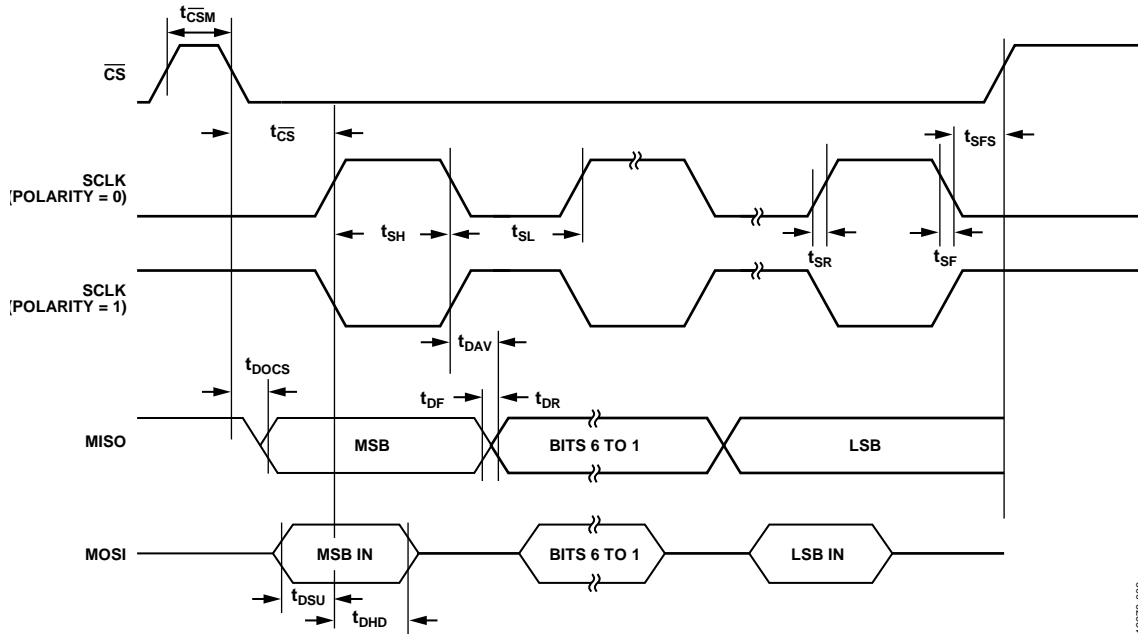

Figure 6. SPI Slave Mode Timing (Phase Mode = 0)

13272-006

**Table 9. MDIO vs MDC Timing**

Parameter	Description	Min	Typ	Max	Unit
$t_{SETUP}$	MDIO setup before MCK edge	10			ns
$t_{HOLD}$	MDIO valid after MCK edge	10			ns
$t_{DELAY}$	Data output after MCK edge			100	ns

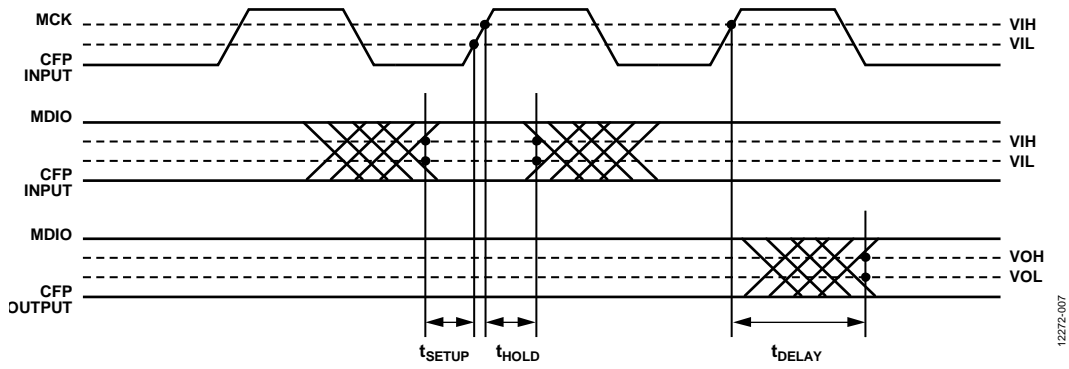

Figure 7. MDIO Timing

## ABSOLUTE MAXIMUM RATINGS

All requirements applicable to each pin must be met. Where multiple limits apply to a pin each one must be met individually. The limits apply according to the functionality of the pins at the time. Pins that can be either analog or digital, that is, that have two types indicated in the pin descriptions, must meet the limits for both types. For pin types, see Table 11.

When powered up, it is required that all ground pins plus ADC\_REFN be connected together to a node referred to as GND in Table 10. The limits that are listed must be reduced by any difference between any GNDs. Also, it is required that AVDD3 is connected to AVDD4 and that IOVDD1 to IOVDD3 are connected together.

**Table 10. Absolute Maximum Ratings**

Parameter	Rating
Any Pin to GND	-0.3 V to +3.9 V
Any PVDDx Pin to GND	-0.3 V to +2.8 V
MDIO <sup>1</sup> , MCK, and PRTADDR0-4 in MDIO Mode to GND	-0.3 V to +2.1 V
Between Any of AVDDx, IOVDDx, and VDD1 Pins	-0.3 V to +0.3 V
Any Type I Pin to GND <sup>2</sup>	-0.3 V to IOVDDx + 0.3 V
Any Type AI or AO Pin to GND <sup>3</sup>	-0.3 V to AVDDx + 0.3 V
Any IDACx, CDAMPx, IDACTST, IREF to GND	-0.3 V to PVDDx + 0.3 V
ADC_REFP to GND	-0.3 V to AVDDx + 0.3 V
Total Positive GPIO Pin Currents	0 mA to 30 mA
Total Negative GPIO Pin Currents	-30 mA to 0 mA
Maximum Power Dissipation	1 W
Operating Ambient Temperature Range	-40°C to +105°C
Storage Temperature Range	-65°C to +160°C
Operating Junction Temperature Range	-40°C to +150°C
ESD HBM	2 kV
ESD FICDM	1 kV

<sup>1</sup> Note this pin is always in MDIO mode.

<sup>2</sup> This limit does not apply if no current can be drawn by external circuits on IOVDDx because then IOVDD follows to a suitable level.

<sup>3</sup> This limit does not apply if no current can be drawn by external circuits on AVDDx because then AVDD follows to a suitable level.

Stresses at or above those listed under Absolute Maximum Ratings may cause permanent damage to the product. This is a stress rating only; functional operation of the product at these or any other conditions above those indicated in the operational section of this specification is not implied. Operation beyond the maximum operating conditions for extended periods may affect product reliability.

## ESD CAUTION



**ESD (electrostatic discharge) sensitive device.** Charged devices and circuit boards can discharge without detection. Although this product features patented or proprietary protection circuitry, damage may occur on devices subjected to high energy ESD. Therefore, proper ESD precautions should be taken to avoid performance degradation or loss of functionality.

### PIN CONFIGURATION AND FUNCTION DESCRIPTIONS

	1	2	3	4	5	6	7	8	9	10	11					
A	IDAC_TST	IDAC0	PVDD0	PVDD2	IDAC2	PGND	IDAC3	PVDD3	PVDD1	IDAC1	IREF					
B	IOVDD1	RESET	P3.3/ PRTADDR3/ PLAI[15]	CDAMP0	CDAMP2	PGND	CDAMP3	CDAMP1	P1.0/SIN/ ECLKIN/ PLAI[4]	P1.1/SOUT/ PLACLK1/ PLAI[5]	P1.2/ PWM0/ PLAI[6]					
C	IOGND1	P0.0/ SCLK0/ PLAI[0]	P2.3/BM	P2.2/ IRQ4/FOR/ CLKOUT/ PLAI[10]	P2.0/IRQ2/ PWMTRIP/ PLACLK2/ PLAI[8]	P1.3/ PWM1/ PLAI[7]	P1.4/ PWM2/ SCLK1/ PLAO[10]	P1.5/ PWM3/ MISO1/ PLAO[11]	P1.6/ PWM4/ MOSI1/ PLAO[12]	P1.7/IRQ1/ PWM5/ CS1/ PLAO[13]	P3.4/ PRTADDR4/ PLAO[26]					
D	P0.2/ MOSI0/ PLAI[2]	P0.1/ MISO0/ PLAI[1]	P3.2/ PRTADDR2/ PLAI[14]	<b>ADuCM320</b> TOP VIEW (Not to Scale)					P2.4/IRQ5/ ADCCONV/ PWM6/ PLAO[18]	DGND2	IOVDD2					
E	P0.5/ SDA0/ PLAO[3]	P0.4/ SCL0/ PLAO[2]	P0.3/ IRQ0/CS0/ PLACLK0/ PLAI[3]											SWCLK	SWDIO	IOGND2
F	P2.6/ IRQ7/ PLAO[20]	P0.7/ SDA1/ PLAO[5]	P0.6/ SCL1/ PLAO[4]											AVDD_ REG0	AVDD_ REG1	VREF_1V2
G	P2.7/ IRQ8/ PLAO[21]	P3.1/ PRTADDR1/ PLAI[13]	P3.0/ PRTADDR0/ PLAI[12]											AIN15/ P4.7	AIN13/ P4.5	AVDD4
H	P3.5/ MCK/ PLAO[27]	XTALO	MDIO											AIN14/ P4.6	AIN12/ P4.4	AGND4
J	IOVDD3	XTALI	VDAC7/ P5.2	VDAC4	AGND1	AIN0	AIN1	AIN2	AIN7	AIN10	AIN11/ BUF_ VREF2V5					
K	IOGND3	DVDD_ 2V5	VDAC6/ P5.1	VDAC3/ P5.0	VDAC1	VDD1	AGND2	AIN3	AIN6	AIN9/ P4.3	ADC_ REFP					
L	DGND1	DVDD_1V8	VDAC5	VDAC2/ P3.7/ PLAO[29]	VDAC0/ P5.3	AVDD3	AGND3	AIN4	AIN5	AIN8/ P4.2	ADC_ REFN					

13272-008

Figure 8. Pin Configuration

Table 11. Pin Function Descriptions

Pin No.	Mnemonic	Type <sup>1</sup>	Description
B2	RESET	I	Reset Input (Active Low). An internal pull-up resistor is included.
C2	P0.0/SCLK0/PLAI[0]	I/O	Digital I/O Port 0.0 (P0.0). SPI0 Clock (SCLK0). Input to PLA Element 0 (PLAI[0]).
D2	P0.1/MISO0/PLAI[1]	I/O	Digital I/O Port 0.1 (P0.1). SPI0 Master In, Slave Out (MISO0). Input to PLA Element 1 (PLAI[1]).
D1	P0.2/MOSI0/PLAI[2]	I/O	Digital I/O Port 0.2 (P0.2). SPI0 Master Out, Slave In (MOSI0). Input to PLA Element 2 (PLAI[2]).
E3	P0.3/IRQ0/CS0/PLACLK0/PLAI[3]	I/O	Digital I/O Port 0.3 (P0.3). External Interrupt 0 (IRQ0). SPI0 Chip Select 0 (CS0). When using SPI0, configure this pin as CS0. PLA Clock 0 (PLACLK0). Input to PLA Element 3 (PLAI[3]).
E2	P0.4/SCL0/PLAO[2]	I/O	Digital I/O Port 0.4 (P0.4). I <sup>2</sup> C0 Serial Clock (SCL0). Output of PLA Element 2 (PLAO[2]).
E1	P0.5/SDA0/PLAO[3]	I/O	Digital I/O Port 0.5 (P0.5). I <sup>2</sup> C0 Serial Data (SDA0). Output of PLA Element 3 (PLAO[3]).

Pin No.	Mnemonic	Type <sup>1</sup>	Description
F3	P0.6/SCL1/PLAO[4]	I/O	Digital I/O Port 0.6 (P0.6). I <sup>2</sup> C1 Serial Clock (SCL1). Output of PLA Element 4 (PLAO[4]).
F2	P0.7/SDA1/PLAO[5]	I/O	Digital I/O Port 0.7 (P0.7). I <sup>2</sup> C1 Serial Data (SDA1). Output of PLA Element 5 (PLAO[5]).
B9	P1.0/SIN/ECLKIN/PLAI[4]	I/O	Digital I/O Port 1.0 (P1.0). UART Input (SIN). External Input Clock (ECLKIN). Input to PLA Element 4 (PLAI[4]).
B10	P1.1/SOUT/PLACK1/PLAI[5]	I/O	Digital I/O Port 1.1 (P1.1). UART Output (SOUT) PLA Clock 1 (PLACK1). Input to PLA Element 5 (PLAI[5]).
B11	P1.2/PWM0/PLAI[6]	I/O	Digital I/O Port 1.2 (P1.2). PWM Output 0 (PWM0). Input to PLA Element 6 (PLAI[6]).
C6	P1.3/PWM1/PLAI[7]	I/O	Digital I/O Port 1.3 (P1.3). PWM Output 1 (PWM1). Input to PLA Element 7 (PLAI[7]).
C7	P1.4/PWM2/SCLK1/PLAO[10]	I/O	Digital I/O Port 1.4 (P1.4). PWM Output 2 (PWM2). SPI1 Clock (SCLK1). Output of PLA Element 10 (PLAO[10]).
C8	P1.5/PWM3/MISO1/PLAO[11]	I/O	Digital I/O Port 1.5 (P1.5). PWM Output 3 (PWM3). SPI1 Master In, Slave Out (MISO1). Output of PLA Element 11 (PLAO[11]).
C9	P1.6/PWM4/MOSI1/PLAO[12]	I/O	Digital I/O Port 1.6 (P1.6). PWM Output 4 (PWM4). SPI1 Master Out, Slave Input (MOSI1). Output of PLA Element 12 (PLAO[12]).
C10	P1.7/IRQ1/PWM5/CS1/PLAO[13]	I/O	Digital I/O Port 1.7 (P1.7). External Interrupt 1 (IRQ1). PWM Output 5 (PWM5). SPI1 Chip Select 1 (CS1). When using SPI1, configure this pin as CS1. Output of PLA Element 13 (PLAO[13]).
C5	P2.0/IRQ2/PWMTRIP/PLACK2/PLAI[8]	I/O	Digital I/O Port 2.0 (P2.0). External Interrupt 2 (IRQ2). PWM Trip (PWMTRIP). PLA Input Clock 2 (PLACK2). Input to PLA Element 8 (PLAI[8]).
C4	P2.2/IRQ4/ $\overline{\text{POR}}$ /CLKOUT/PLAI[10]	I/O	Digital I/O Port 2.2 (P2.2). External Interrupt 4 (IRQ4). Reset Output ( $\overline{\text{POR}}$ ). This pin function is an output and it is the default for Pin C4. Clock Output (CLKOUT). Input to PLA Element 10 (PLAI[10]).
C3	P2.3/BM	I/O	Digital I/O Port 2.3 (P2.3). Boot Mode (BM). This pin determines the start-up sequence after every reset. Pull-up is enabled at power-up.

Pin No.	Mnemonic	Type <sup>1</sup>	Description
D9	P2.4/IRQ5/ADCCONV/PWM6/PLAO[18]	I/O	Digital I/O Port 2.4 (P2.4). External Interrupt 5 (IRQ5). External Input to Start ADC Conversions (ADCCONV). PWM Output 6 (PWM6). Output of PLA Element 18 (PLAO[18]).
F1	P2.6/IRQ7/PLAO[20]	I/O	Digital I/O Port 2.6 (P2.6). External Interrupt 7 (IRQ7). Output of PLA Element 20 (PLAO[20]).
G1	P2.7/IRQ8/PLAO[21]	I/O	Digital I/O Port 2.7 (P2.7). External Interrupt 8 (IRQ8). Output of PLA Element 21 (PLAO[21]).
G3	P3.0/PRTADDR0/PLAI[12]	I/O	Digital I/O Port 3.0 (P3.0). MDIO Port Address Bit 0 (PRTADDR0). See the digital inputs parameter in Table 1 for details. Input to PLA Element 12 (PLAI[12]).
G2	P3.1/PRTADDR1/PLAI[13]	I/O	Digital I/O Port 3.1 (P3.1). MDIO Port Address Bit 1 (PRTADDR1). See the digital inputs parameter in Table 1 for details. Input to PLA Element 13 (PLAI[13]).
D3	P3.2/PRTADDR2/PLAI[14]	I/O	Digital I/O Port 3.2 (P3.2). MDIO Port Address Bit 2 (PRTADDR2). See the digital inputs parameter in Table 1 for details. Input to PLA Element 14 (PLAI[14]).
B3	P3.3/PRTADDR3/PLAI[15]	I/O	Digital I/O Port 3.3 (P3.3). MDIO Port Address Bit 3 (PRTADDR3). See the digital inputs parameter in Table 1 for details. Output of PLA Element 15 (PLAI[15]).
C11	P3.4/PRTADDR4/PLAO[26]	I/O	Digital I/O Port 3.4 (P3.4). MDIO Port Address Bit 4 (PRTADDR4). See the digital inputs parameter in Table 1 for details. Output of PLA Element 26 (PLAO[26]).
H1	P3.5/MCK/PLAO[27]	I/O	Digital I/O Port 3.5 (P3.5). MDIO Clock (MCK) See the digital inputs parameter in Table 1 for more details. Output of PLA Element 27 (PLAO[27]).
H3	MDIO	I/O	MDIO Data.
E9	SWCLK	I	Serial Wire Debug Clock.
E10	SWDIO	I/O	Serial Wire Bidirectional Data.
F11	VREF_1V2	S	1.2 V Reference. This pin cannot be used to source current externally. Connect VREF_1V2 to AGNDx via a 470 nF capacitor.
A11	IREF	AI	IDAC Reference Current. This pin generates the reference current for the IDACs and is set by an external resistor, R <sub>EXT</sub> . Connect R <sub>EXT</sub> from IREF to AGND4.
J6	AIN0	AI	Analog Input 0.
J7	AIN1	AI	Analog Input 1.
J8	AIN2	AI	Analog Input 2.
K8	AIN3	AI	Analog Input 3.
L8	AIN4	AI	Analog Input 4.
L9	AIN5	AI	Analog Input 5. AIN5 can be the –ve input for the comparator.
K9	AIN6	AI	Analog Input 6. AIN6 is also the +ve input for the comparator.
J9	AIN7	AI	Analog Input 7.
L10	AIN8/P4.2	AI/I/O	Analog Input 8 (AIN8). Digital I/O Port 4.2 (P4.2).
K10	AIN9/P4.3	AI/I/O	Analog Input 9 (AIN9). Digital I/O Port 4.3 (P4.3).
J10	AIN10	AI	Analog Input 10.

Pin No.	Mnemonic	Type <sup>1</sup>	Description
J11	AIN11/BUF_VREF2V5	AI/AO	Analog Input 11 (AIN11). Buffered 2.5 V Bias (BUF_VREF2V5). The maximum load = 1.2 mA. Connect BUF_VREF2V5 to AGNDx via a 100 nF capacitor.
H10	AIN12/P4.4	AI/I/O	Analog Input 12 (AIN12). Digital I/O Port 4.4 (P4.4).
G10	AIN13/P4.5	AI/I/O	Analog Input 13 (AIN13). Digital I/O Port 4.5 (P4.5).
H9	AIN14/P4.6	AI/I/O	Analog Input 14 (AIN14). Digital I/O Port 4.6 (P4.6).
G9	AIN15/P4.7	AI/I/O	Analog Input 15 (AIN15). Digital I/O Port 4.7 (P4.7).
L5	VDAC0/P5.3	AO/I/O	Voltage DAC0 Output (VDAC0). Digital I/O Port 5.3 (P5.3).
K5	VDAC1	AO	Voltage DAC1 Output.
L4	VDAC2/P3.7/PLAO[29]	AO/I/O	Voltage DAC2 Output (VDAC2). Digital I/O Port 3.7 (P3.7). Output of PLA Element 29 (PLAO[29]).
K4	VDAC3/P5.0	AO/I/O	Voltage DAC3 Output (VDAC3). Digital I/O Port 5.0 (P5.0).
J4	VDAC4	AO	Voltage DAC4 Output (VDAC4).
L3	VDAC5	AO	Voltage DAC5 Output (VDAC5).
K3	VDAC6/P5.1	AO/I/O	Voltage DAC6 Output (VDAC6). Digital I/O Port 5.1 (P5.1).
J3	VDAC7/P5.2	AO/I/O	Voltage DAC7 Output (VDAC7). Digital I/O Port 5.2 (P5.2).
A2	IDAC0	AO	IDAC0. 0 mA to 150 mA full-scale output.
A3	PVDD0	S	Power for IDAC0.
B4	CDAMP0	AI	Damping Capacitor 0. Connect damping capacitor from this pin to PVDD0.
A10	IDAC1	AO	IDAC1. 0 mA to 150 mA full-scale output.
A9	PVDD1	S	Power for IDAC1.
B8	CDAMP1	AI	Damping Capacitor 1. Connect damping capacitor from this pin to PVDD1.
A5	IDAC2	AO	IDAC2. 0 mA to 150 mA full-scale output.
A4	PVDD2	S	Power for IDAC2.
B5	CDAMP2	AI	Damping Capacitor 2. Connect damping capacitor from this pin to PVDD2.
A7	IDAC3	AO	IDA3C. 0 mA to 150 mA full-scale output.
A8	PVDD3	S	Power for IDAC3.
B7	CDAMP3	AI	Damping Capacitor 3. Connect damping capacitor from this pin to PVDD3.
B6	PGND	S	Power Supply Ground for IDACs.
A6	PGND	S	Power Supply Ground for IDACs.
A1	IDAC_TST	AI/AO	Pin for IDAC Test Purposes. Leave IDAC_TST unconnected.
L2	DVDD_1V8	AO	1.8 V Digital Supply. A 470 nF capacitor to DGND1 must be connected to this pin to stabilize the internal 1.8 V regulator that supplies flash memory and the ARM Cortex-M3 processor.
K2	DVDD_2V5	AO	2.5 V Digital Supply. A 470 nF capacitor to IOGND3 must be connected to this pin to stabilize the internal 2.5 V regulator that supplies the analog digital control.
F9	AVDD_REG0	AO	Analog Regulator 0 Supply. A 470 nF capacitor to AGND4 must be connected to this pin to stabilize the internal 2.5 V regulator that supplies the ADC.
F10	AVDD_REG1	AO	Analog Regulator 1 Supply. Output of 2.5 V on-chip LDO regulator. A 470 nF capacitor to AGND4 must be connected to this pin. This regulator supplies the IDACs.
L1	DGND1	S	Digital Ground 1 for DVDD_1V8.
D10	DGND2	S	Digital Ground 2. Connect to DGND1.
B1	IOVDD1	S	3.3 V GPIO Supply.

Pin No.	Mnemonic	Type <sup>1</sup>	Description
D11	IOVDD2	S	3.3 V GPIO Supply and Interdie Communications.
J1	IOVDD3	S	3.3 V GPIO Supply.
C1	IOGND1	S	Ground for IOVDD1.
E11	IOGND2	S	Ground for IOVDD2.
K1	IOGND3	S	Ground for IOVDD3 and Interdie Communications.
J5	AGND1	S	Analog Ground for VDD1.
K7	AGND2	S	ESD Ground for Pad Ring.
L7	AGND3	S	Ground for AVDD3.
H11	AGND4	S	Ground for AVDD4, AVDD_REG0, and AVDD_REG1.
K6	VDD1	S	3.3 V Supply for Digital Die.
L6	AVDD3	S	VDAC and IDAC Supply (3.3 V).
G11	AVDD4	S	ADC Supply (3.3 V).
L11	ADC_REFN	AO/A	Decoupling Capacitor Connection for ADC Reference Buffer. Connect this pin to AGND4.
K11	ADC_REFP	AO/A	Decoupling Capacitor Connection for ADC Reference Buffer. Connect this pin to a 4.7 $\mu$ F capacitor to the ADC_REFN pin. ADC_REFP can be overdriven by an external reference.
H2	XTALO	O	Output from the Crystal Oscillator Inverter. When not using an external crystal, leave XTALO unconnected.
J2	XTALI	I	Input to the Crystal Oscillator Inverter and Input to the Internal Clock Generator Circuits. When not using an external crystal, connect XTALI to DGND.

<sup>1</sup> AI is analog input, AO is analog output, I is digital input, O is digital output, S is supply.

### TYPICAL PERFORMANCE CHARACTERISTICS

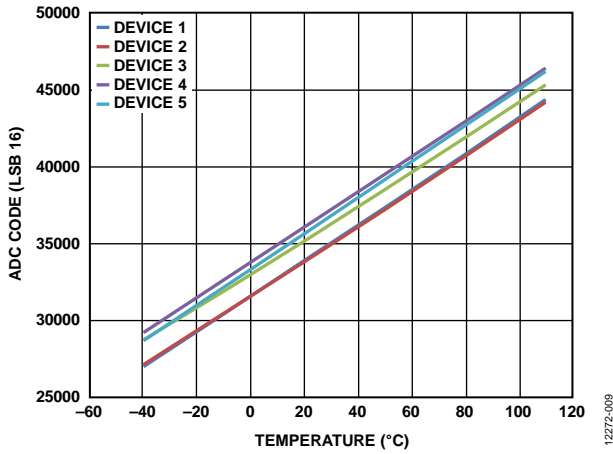

Figure 9. Typical Temperature Measurement vs. Internal Temperature ( $V_{DD} = 3.3\text{ V}$ , 50 kSPS)

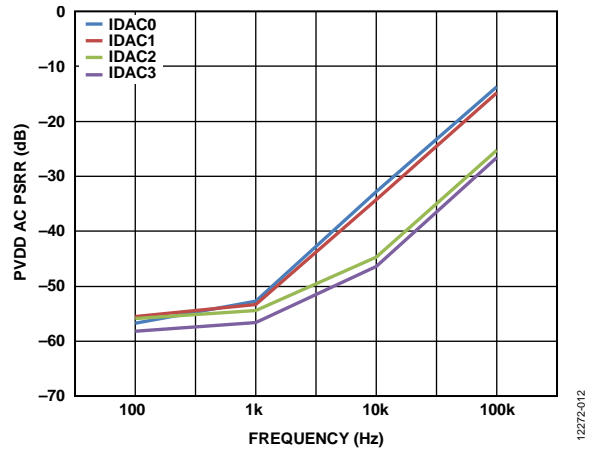

Figure 12. Typical PVDD AC PSRR vs. Frequency

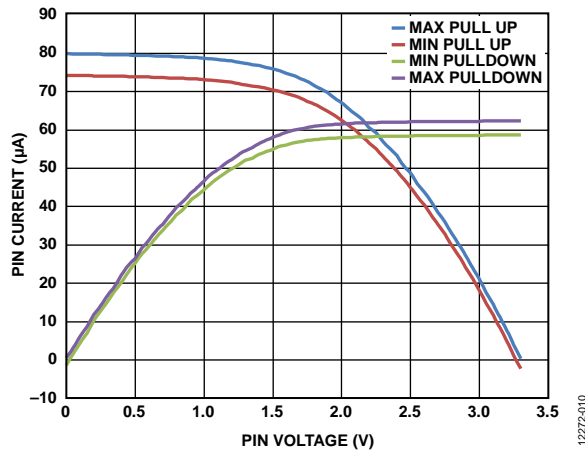

Figure 10. Typical Pull-Up/Pull-Down Pin Current vs. Pin Voltage ( $V_{DD} = 3.3\text{ V}$ , 25°C)

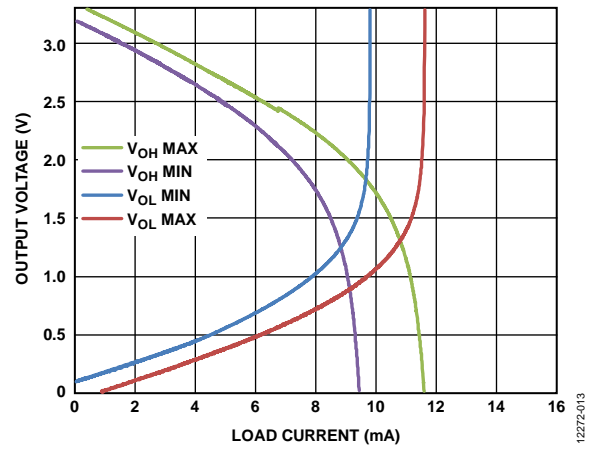

Figure 13. Typical Output Voltage vs. Load Current

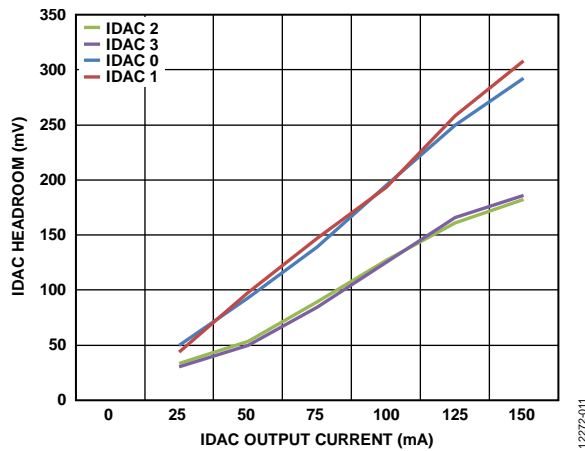

Figure 11. Typical IDAC Headroom vs. IDAC Output Current

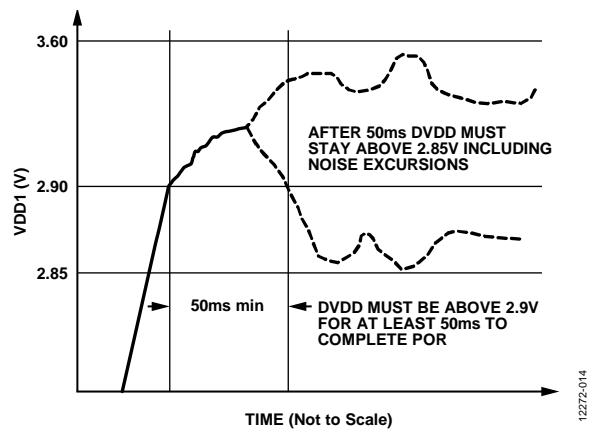

Figure 14. VDD1 Power-On Requirements

## RECOMMENDED CIRCUIT AND COMPONENT VALUES

Figure 15 shows a typical connection diagram for the [ADuCM320](#).

Supplies and regulators must be adequately decoupled with capacitors connected between the AVDDx, PVDDx, DVDD\_x, AVDD\_REGx, IOVDDx, and VDD1 balls and their associated GND balls (AGNDx, PGND, IOGNDx, and DGNDx). Table 11 indicates which ground balls are paired with which supply balls.

There are four digital supply balls, IOVDD1, IOVDD2, IOVDD3, and VDD1. Decouple these balls with a 100 nF capacitor placed as near as possible to each of the four balls and their associated GND balls (IOGNDx and AGND1, respectively). In addition, place a 10  $\mu$ F capacitor conveniently near to these balls.

Similarly, the analog supply pins, AVDD3 and AVDD4, each require a 100 nF capacitor placed as near as possible to each ball and its associated AGNDx ball, and place a 10  $\mu$ F capacitor conveniently near to these balls.

The IDACs source their output currents from the PVDDx supply balls. Each PVDDx supply ball must have a 100 nF capacitor near to each ball and their associated GND balls (PGND). In addition, place at least one 10  $\mu$ F capacitor at the source of the PVDDx supply.

The IDAC output filters depend on a 10 nF capacitor being placed between the CDAMPx and PVDDx.

The ADC reference requires a 4.7  $\mu$ F capacitor placed between ADC\_REFP and ADC\_REFN and located as near as possible to each ball. ADC\_REFN must be connected directly to AGND4.

The [ADuCM320](#) contains four internal regulators. These regulators require external decoupling capacitors. The DVDD\_1V8 and DVDD\_2V5 balls each require a 470 nF capacitor to DGND1 and IOGND3, respectively. AVDD\_REG0 and AVDD\_REG1 each require a decoupling capacitor to AGND4.

To generate an accurate and low drift reference current, connect the IREF ball to AGND4 via a low ppm 3.16 k $\Omega$  resistor.

Take care in the layout to ensure that currents flowing from the ground end of each decoupling capacitor to its associated ground ball share as little track as possible with other ground currents on the printed circuit board.

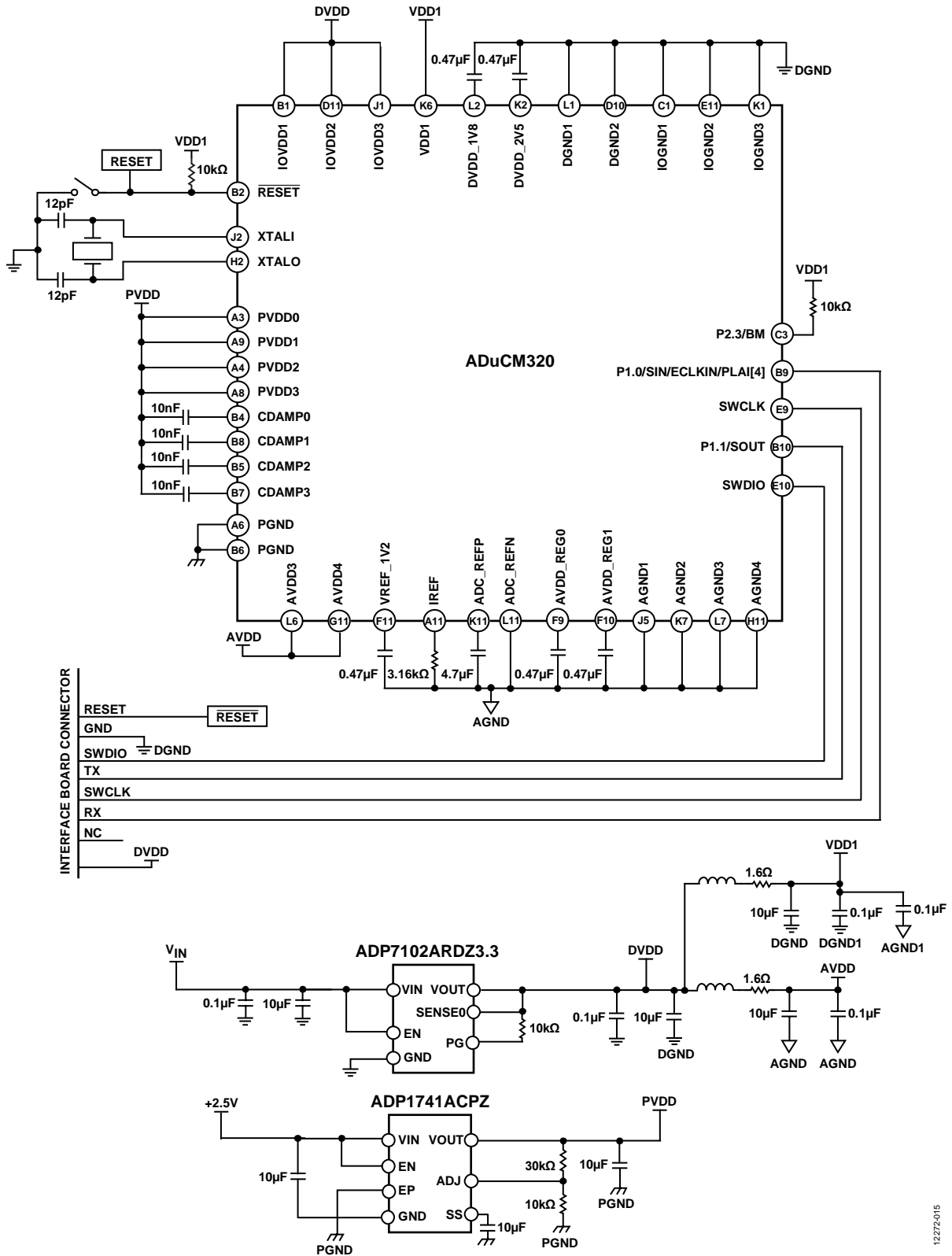
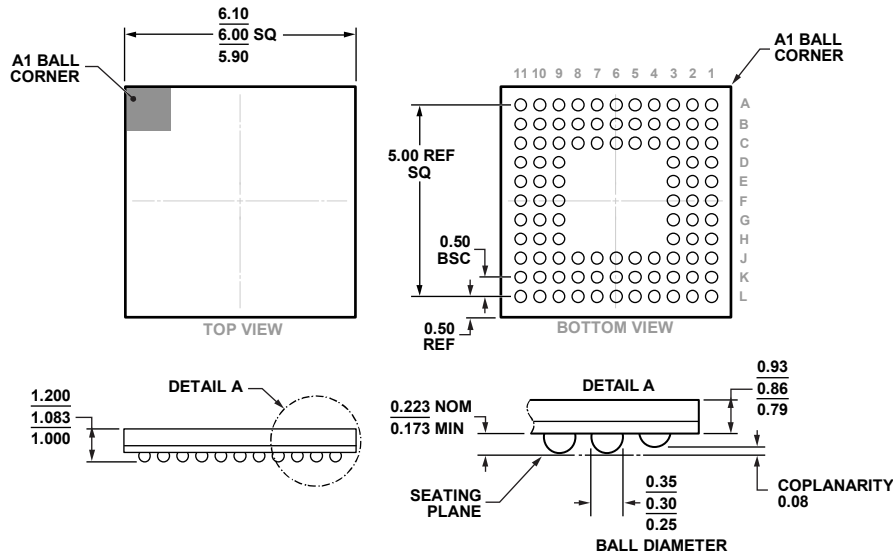

Figure 15. Recommended Circuit and Component Values

12272-015

PACKAGING AND ORDERING INFORMATION

OUTLINE DIMENSIONS



COMPLIANT TO JEDEC STANDARDS MO-195-AC WITH THE EXCEPTION TO BALL COUNT.

Figure 16. 96-Ball Chip Scale Package Ball Grid Array [CSP\_BGA] (BC-96-2)  
Dimensions shown in millimeters

04-02-2013-A

ORDERING GUIDE

Model <sup>1</sup>	Temperature Range	Package Description	Package Option	Ordering Quantity
ADuCM320BBCZ	-40°C to +105°C	96-Ball Chip Scale Package Ball Grid Array [CSP_BGA]	BC-96-2	429
ADuCM320BBCZ-RL	-40°C to +105°C	96-Ball Chip Scale Package Ball Grid Array [CSP_BGA]	BC-96-2	2,500
EV-ADuCM320QSPZ		Evaluation Board with QuickStart Development System		1

<sup>1</sup> Z = RoHS Compliant Part.

## Looking for pricing, stock, or lifecycle information?

Click below to explore more details on WIN SOURCE:

 [View ADUCM320BBCZ on WIN SOURCE](#)

 [Analog Devices Inc. Information](#)

## Optimize Your Supply Chain with WIN SOURCE Solutions

-  Global Sourcing Solution
-  Obsolete Management
-  Cost Control Management
-  Shortage Management
-  Alternative Solution
-  Excess Inventory Management