



## FEATURES

- Voltage controlled amplifier/attenuator**
- Operating frequency 10 MHz to 3 GHz**
- Optimized for controlling output power**
- High linearity: OIP3 31 dBm at 900 MHz**
- Output noise floor: -150 dBm/Hz at 900 MHz**
- 50  $\Omega$  input and output impedances**
- Single-ended or differential operation**
- Wide gain control range: -34 dB to +22 dB at 900 MHz**
- Linear in dB gain control function, 20 mV/dB**
- Single-supply 4.75 V to 5.25 V**

## APPLICATIONS

- Transmit and receive power control at RF and IF**

## GENERAL DESCRIPTION

The ADL5330 is a high performance, voltage controlled, variable gain amplifier (VGA)/attenuator for use in applications with frequencies up to 3 GHz. The balanced structure of the signal path minimizes distortion while it also reduces the risk of spurious feedforward at low gains and high frequencies caused by parasitic coupling. While operation between a balanced source and load is recommended, a single sided input is internally converted to differential form.

The input impedance is 50  $\Omega$  from INHI to INLO. The outputs are usually coupled into a 50  $\Omega$  grounded load via a 1:1 balun. A single supply of 4.75 V to 5.25 V is required.

The 50  $\Omega$  input system converts the applied voltage to a pair of differential currents with high linearity and good common rejection even when driven by a single sided source. The signal currents are then applied to a proprietary voltage controlled attenuator providing precise definition of the overall gain under the control of the linear in dB interface. The GAIN pin accepts a voltage from 0 V at minimum gain to 1.4 V at full gain with a 20 mV/dB scaling factor.

## FUNCTIONAL BLOCK DIAGRAM

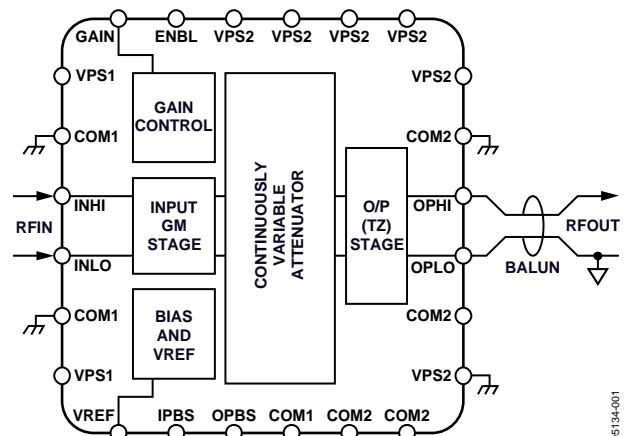

Figure 1.

05134-001

The output of the high accuracy wideband attenuator is applied to a differential transimpedance output stage. The output stage sets the 50  $\Omega$  differential output impedances and drives the OPHI and OPLO pins. The ADL5330 has a power-down function. It can be powered down by a Logic LO input on the ENBL pin. The current consumption in power-down mode is 250  $\mu$ A.

The ADL5330 is fabricated on an Analog Devices, Inc., proprietary high performance, complementary bipolar IC process. The ADL5330 is available in a 24-lead (4 mm  $\times$  4 mm), Pb-free LFCSP package and is specified for operation from ambient temperatures of -40°C to +85°C. An evaluation board is also available.

## TABLE OF CONTENTS

Features .....	1	Basic Connections .....	13
Applications .....	1	RF Input/Output Interface .....	14
Functional Block Diagram .....	1	Gain Control Input .....	15
General Description .....	1	Automatic Gain Control .....	15
Revision History .....	2	Interfacing to an IQ Modulator .....	17
Specifications .....	3	WCDMA Transmit Application .....	18
Absolute Maximum Ratings .....	5	CDMA2000 Transmit Application .....	19
ESD Caution .....	5	Soldering Information .....	19
Pin Configuration and Function Descriptions .....	6	Evaluation Board .....	20
Typical Performance Characteristics .....	7	Outline Dimensions .....	24
Theory of Operation .....	12	Ordering Guide .....	24
Applications Information .....	13		

## REVISION HISTORY

### 11/2017—Rev. A to Rev. B

Changed LFCSP_VQ to LFCSP .....	Throughout
Changes to Figure 2 and Table 3 .....	6
Updated Outline Dimensions .....	24
Changes to Ordering Guide .....	24

### 6/2005—Rev. 0 to Rev. A

Changes to Figure 1 .....	1
Changes to Table 1 .....	3
Changes to Table 2 .....	5
Changes to Table 3 .....	6
Changes to Figure 27 .....	11
Changes to Figure 35 .....	14
Changes to the Gain Control Input Section .....	15
Changes to Figure 42 .....	17

### 4/2005—Revision 0: Initial Version

## SPECIFICATIONS

$V_S = 5\text{ V}$ ;  $T_A = 25^\circ\text{C}$ ; M/A-COM ETC1-1-13 1:1 balun at input and output for single-ended  $50\ \Omega$  match.

Table 1.

Parameter	Conditions	Min	Typ	Max	Unit
<b>GENERAL</b>					
Usable Frequency Range		0.01		3	GHz
Nominal Input Impedance	Via 1:1 single-sided-to-differential balun		50		$\Omega$
Nominal Output Impedance	Via 1:1 differential-to-single-sided balun		50		$\Omega$
<b>100 MHz</b>					
Gain Control Span	$\pm 3\text{ dB}$ gain law conformance		58		dB
Maximum Gain	$V_{\text{GAIN}} = 1.4\text{ V}$		23		dB
Minimum Gain	$V_{\text{GAIN}} = 0.1\text{ V}$		-35		dB
Gain Flatness vs. Frequency	$\pm 30\text{ MHz}$ around center frequency, $V_{\text{GAIN}} = 1.0\text{ V}$ (differential output)		0.09		dB
Gain Control Slope			20.7		mV/dB
Gain Control Intercept	Gain = 0 dB, gain = slope ( $V_{\text{GAIN}}$ – intercept)		0.88		V
Input Compression Point	$V_{\text{GAIN}} = 1.2\text{ V}$		1.8		dBm
Input Compression Point	$V_{\text{GAIN}} = 1.4\text{ V}$		-0.3		dBm
Output Third-Order Intercept (OIP3)	$V_{\text{GAIN}} = 1.4\text{ V}$		38		dBm
Output Noise Floor <sup>1</sup>	20 MHz carrier offset, $V_{\text{GAIN}} = 1.4\text{ V}$		-140		dBm/Hz
Noise Figure	$V_{\text{GAIN}} = 1.4\text{ V}$		7.8		dB
Input Return Loss <sup>2</sup>	$1\text{ V} < V_{\text{GAIN}} < 1.4\text{ V}$		-12.8		dB
Output Return Loss <sup>2</sup>			-15.5		dB
<b>450 MHz</b>					
Gain Control Span	$\pm 3\text{ dB}$ gain law conformance		57		dB
Maximum Gain	$V_{\text{GAIN}} = 1.4\text{ V}$		22		dB
Minimum Gain	$V_{\text{GAIN}} = 0.1\text{ V}$		-35		dB
Gain Flatness vs. Frequency	$\pm 30\text{ MHz}$ around center frequency, $V_{\text{GAIN}} = 1.0\text{ V}$ , (differential output)		0.08		dB
Gain Control Slope			20.4		mV/dB
Gain Control Intercept	Gain = 0 dB, gain = slope ( $V_{\text{GAIN}}$ – intercept)		0.89		V
Input Compression Point	$V_{\text{GAIN}} = 1.2\text{ V}$		3.3		dBm
Input Compression Point	$V_{\text{GAIN}} = 1.4\text{ V}$		1.2		dBm
Output Third-Order Intercept (OIP3)	$V_{\text{GAIN}} = 1.4\text{ V}$		36		dBm
Output Noise Floor <sup>1</sup>	20 MHz carrier offset, $V_{\text{GAIN}} = 1.4\text{ V}$		-146		dBm/Hz
Noise Figure	$V_{\text{GAIN}} = 1.4\text{ V}$		8.0		dB
Input Return Loss <sup>2</sup>	$1\text{ V} < V_{\text{GAIN}} < 1.4\text{ V}$		-19		dB
Output Return Loss <sup>2</sup>			-13.4		dB
<b>900 MHz</b>					
Gain Control Span	$\pm 3\text{ dB}$ gain law conformance		53		dB
Maximum Gain	$V_{\text{GAIN}} = 1.4\text{ V}$		21		dB
Minimum Gain	$V_{\text{GAIN}} = 0.2\text{ V}$		-32		dB
Gain Flatness vs. Frequency	$\pm 30\text{ MHz}$ around center frequency, $V_{\text{GAIN}} = 1.0\text{ V}$ (differential output)		0.14		dB
Gain Control Slope			19.7		mV/dB
Gain Control Intercept	Gain = 0 dB, gain = slope ( $V_{\text{GAIN}}$ – intercept)		0.92		V
Input Compression Point	$V_{\text{GAIN}} = 1.2\text{ V}$		2.7		dBm
Input Compression Point	$V_{\text{GAIN}} = 1.4\text{ V}$		1.3		dBm
Output Third-Order Intercept (OIP3)	$V_{\text{GAIN}} = 1.4\text{ V}$		31.5		dBm
Output Noise Floor <sup>1</sup>	20 MHz carrier offset, $V_{\text{GAIN}} = 1.4\text{ V}$		-144		dBm/Hz
Noise Figure	$V_{\text{GAIN}} = 1.4\text{ V}$		9.0		dB

Parameter	Conditions	Min	Typ	Max	Unit
Input Return Loss <sup>2</sup>	$1\text{ V} < V_{\text{GAIN}} < 1.4\text{ V}$		-18		dB
Output Return Loss <sup>2</sup>			-18		dB
<b>2200 MHz</b>					
Gain Control Span	$\pm 3\text{ dB}$ gain law conformance		46		dB
Maximum Gain	$V_{\text{GAIN}} = 1.4\text{ V}$		16		dB
Minimum Gain	$V_{\text{GAIN}} = 0.6\text{ V}$		-30		dB
Gain Flatness vs. Frequency	$\pm 30\text{ MHz}$ around center frequency, $V_{\text{GAIN}} = 1.0\text{ V}$ (differential output)		0.23		dB
Gain Control Slope			16.7		mV/dB
Gain Control Intercept	Gain = 0 dB, gain = slope ( $V_{\text{GAIN}}$ – intercept)		1.06		V
Input Compression Point	$V_{\text{GAIN}} = 1.2\text{ V}$		0.9		dBm
Input Compression Point	$V_{\text{GAIN}} = 1.4\text{ V}$		-2.0		dBm
Output Third-Order Intercept (OIP3)	$V_{\text{GAIN}} = 1.4\text{ V}$		21.2		dBm
Output Noise Floor <sup>1</sup>	20 MHz carrier offset, $V_{\text{GAIN}} = 1.4\text{ V}$		-147		dBm/Hz
Noise Figure	$V_{\text{GAIN}} = 1.4\text{ V}$		12.5		dB
Input Return Loss <sup>2</sup>	$1\text{ V} < V_{\text{GAIN}} < 1.4\text{ V}$		-11.7		dB
Output Return Loss <sup>2</sup>			-9.5		dB
<b>2700 MHz</b>					
Gain Control Span	$\pm 3\text{ dB}$ gain law conformance		42		dB
Maximum Gain	$V_{\text{GAIN}} = 1.4\text{ V}$		10		dB
Minimum Gain	$V_{\text{GAIN}} = 0.7\text{ V}$		-32		dB
Gain Flatness vs. Frequency	$\pm 30\text{ MHz}$ around center frequency, $V_{\text{GAIN}} = 1.0\text{ V}$ (differential output)		0.3		dB
Gain Control Slope			16		mV/dB
Gain Control Intercept	Gain = 0 dB, gain = slope ( $V_{\text{GAIN}}$ – intercept)		1.15		V
Input Compression Point	$V_{\text{GAIN}} = 1.2\text{ V}$		1.2		dBm
Input Compression Point	$V_{\text{GAIN}} = 1.4\text{ V}$		-0.9		dBm
Output Third-Order Intercept (OIP3)	$V_{\text{GAIN}} = 1.4\text{ V}$		17		dBm
Output Noise Floor <sup>1</sup>	20 MHz carrier offset, $V_{\text{GAIN}} = 1.4\text{ V}$		-152		dBm/Hz
Noise Figure	$V_{\text{GAIN}} = 1.4\text{ V}$		14.7		dB
Input Return Loss <sup>2</sup>	$1\text{ V} < V_{\text{GAIN}} < 1.4\text{ V}$		-9.7		dB
Output Return Loss <sup>2</sup>			-5		dB
<b>GAIN CONTROL INPUT</b>					
Gain Control Voltage Range <sup>3</sup>	GAIN pin	0		1.4	V
Incremental Input Resistance	GAIN pin to COM1 pin		1		M $\Omega$
Response Time	Full scale: to within 1 dB of final gain 3 dB gain step, $P_{\text{OUT}}$ to within 1 dB of final gain		380 20		ns ns
<b>POWER SUPPLIES</b>					
Voltage	Pin VPS1, Pin VPS2, Pin COM1, Pin COM2, Pin ENBL	4.75	5	5.25	V
Current, Nominal Active	$V_{\text{GN}} = 0\text{ V}$		100		mA
	$V_{\text{GN}} = 1.4\text{ V}$		215		mA
Current, Disabled	ENBL = LO		250		$\mu\text{A}$

<sup>1</sup> Noise floor varies slightly with output power level. See Figure 9 to Figure 13.

<sup>2</sup> See Figure 27 and Figure 29 for differential input and output impedances.

<sup>3</sup> Minimum gain voltage varies with frequency. See Figure 3 to Figure 7.

## ABSOLUTE MAXIMUM RATINGS

Table 2.

Parameter	Rating
Supply Voltage VPS1, VPS2	5.5 V
RF Input Power at Maximum Gain	5 dBm at 50 $\Omega$
OPHI, OPLO	5.5 V
ENBL	VPS1, VPS2
GAIN	2.5 V
Internal Power Dissipation	1.1 W
$\theta_{JA}$ (with Pad Soldered to Board)	60°C/W
Maximum Junction Temperature	150°C
Operating Temperature Range	-40°C to +85°C
Storage Temperature Range	-65°C to +150°C
Lead Temperature Range (Soldering 60 sec)	300°C

Stresses at or above those listed under Absolute Maximum Ratings may cause permanent damage to the product. This is a stress rating only; functional operation of the product at these or any other conditions above those indicated in the operational section of this specification is not implied. Operation beyond the maximum operating conditions for extended periods may affect product reliability.

### ESD CAUTION



**ESD (electrostatic discharge) sensitive device.** Charged devices and circuit boards can discharge without detection. Although this product features patented or proprietary protection circuitry, damage may occur on devices subjected to high energy ESD. Therefore, proper ESD precautions should be taken to avoid performance degradation or loss of functionality.

### PIN CONFIGURATION AND FUNCTION DESCRIPTIONS

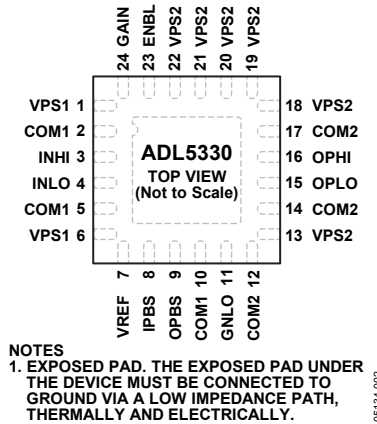

Figure 2. Pin Configuration

Table 3. Pin Function Descriptions

Pin No.	Mnemonic	Descriptions
1, 6, 13, 18 to 22	VPS1, VPS2	Positive Supply. Nominally equal to 5 V.
2, 5, 10	COM1	Common for Input Stage.
3, 4	INHI, INLO	Differential Inputs, AC-Coupled.
7	VREF	Voltage Reference. Output at 1.5 V; normally ac-coupled to ground.
8	IPBS	Input Bias. Normally ac-coupled to ground.
9	OPBS	Output Bias. AC-Coupled to ground.
11	GNLO	Gain Control Common. Connect to ground.
12, 14, 17	COM2	Common for Output Stage.
15	OPLO	Low Side of Differential Output. Bias to $V_P$ with RF chokes.
16	OPHI	High Side of Differential Output. Bias to $V_P$ with RF chokes.
23	ENBL	Device Enable. Apply logic high for normal operation.
24	GAIN	Gain Control Voltage Input. Nominal range 0 V to 1.4 V.
	EPAD	Exposed Pad. The exposed pad under the device must be connected to ground via a low impedance path, thermally and electrically.

### TYPICAL PERFORMANCE CHARACTERISTICS

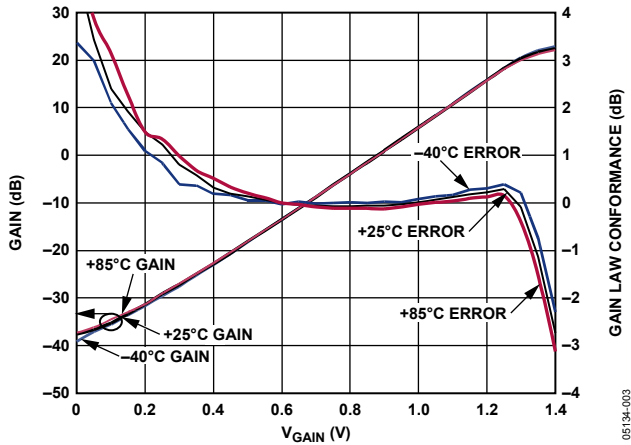

Figure 3. Gain and Gain Law Conformance vs.  $V_{GAIN}$  over Temperature at 100 MHz

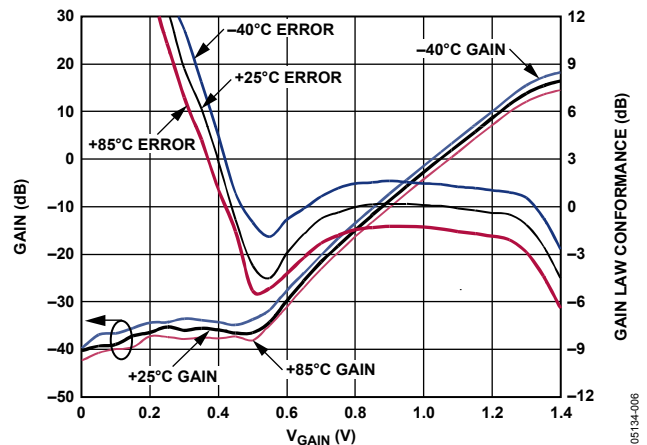

Figure 6. Gain and Gain Law Conformance vs.  $V_{GAIN}$  over Temperature at 2200 MHz

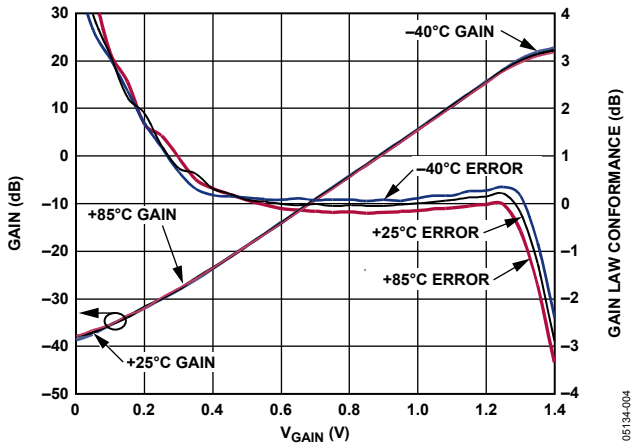

Figure 4. Gain and Gain Law Conformance vs.  $V_{GAIN}$  over Temperature at 450 MHz

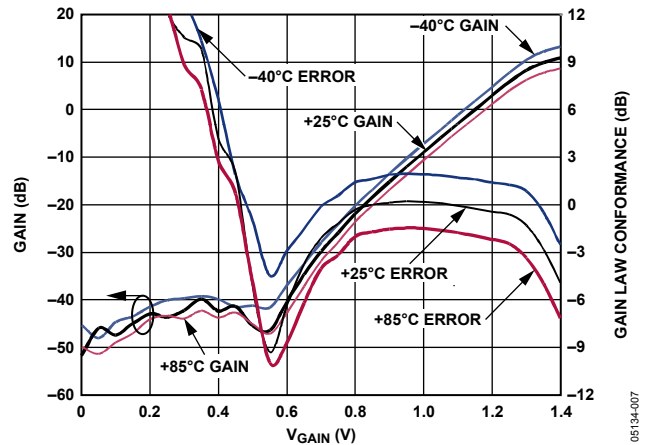

Figure 7. Gain and Gain Law Conformance vs.  $V_{GAIN}$  over Temperature at 2700 MHz

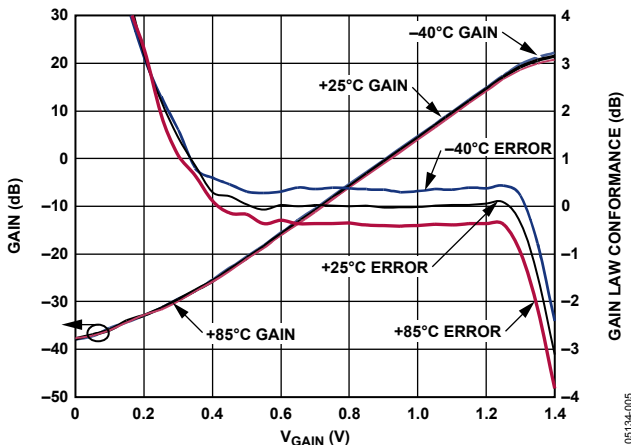

Figure 5. Gain and Gain Law Conformance vs.  $V_{GAIN}$  over Temperature at 900 MHz

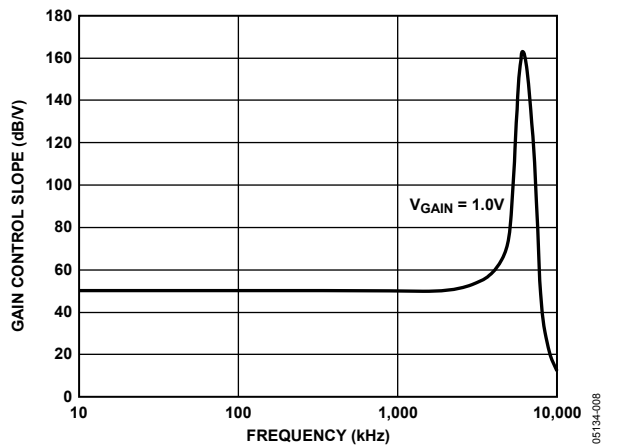

Figure 8. Frequency Response of Gain Control Input, Carrier Frequency = 900 MHz

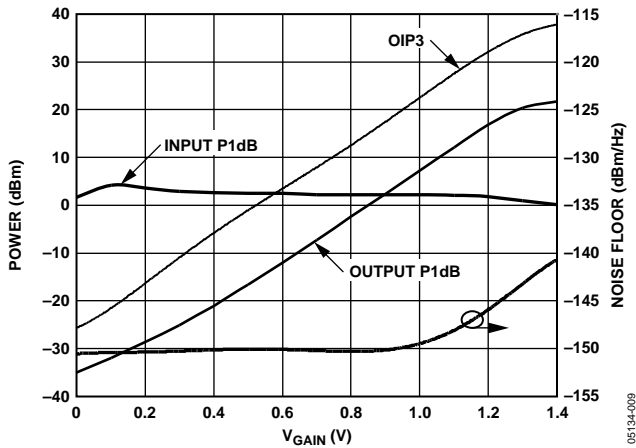

Figure 9. Input Compression Point, Output Compression Point, OIP3, and Noise Floor vs.  $V_{GAIN}$  at 100 MHz

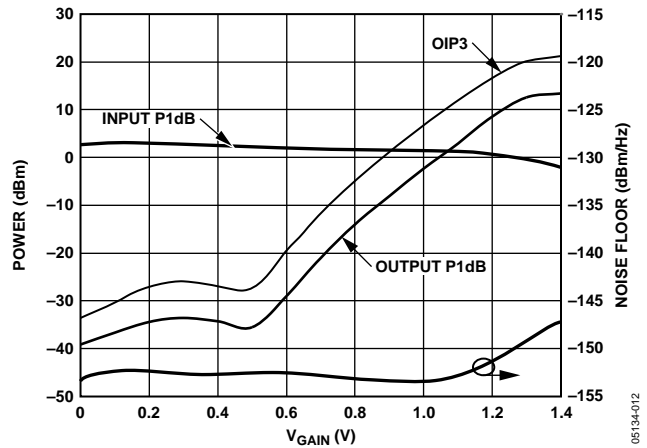

Figure 12. Input Compression Point, Output Compression Point, OIP3, and Noise Floor vs.  $V_{GAIN}$  at 2200 MHz

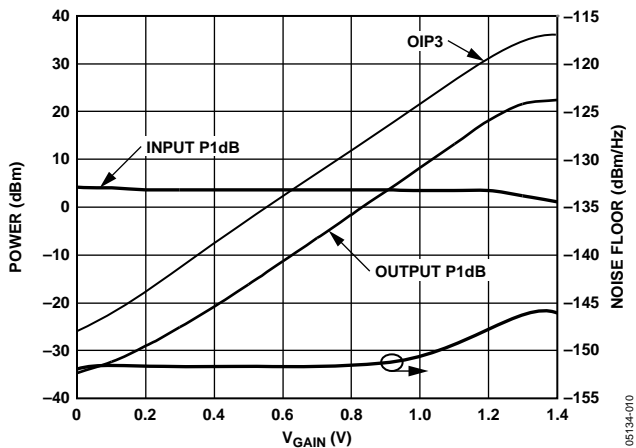

Figure 10. Input Compression Point, Output Compression Point, OIP3, and Noise Floor vs.  $V_{GAIN}$  at 450 MHz

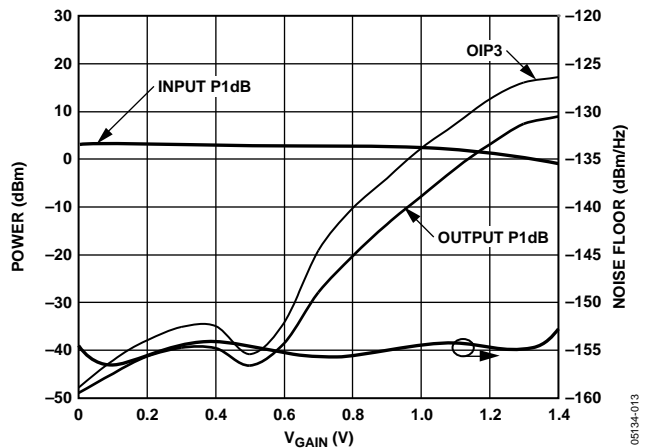

Figure 13. Input Compression Point, Output Compression Point, OIP3, and Noise Floor vs.  $V_{GAIN}$  at 2700 MHz

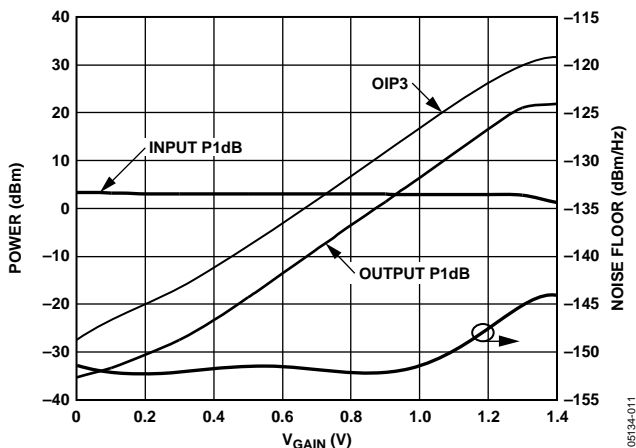

Figure 11. Input Compression Point, Output Compression Point, OIP3, and Noise Floor vs.  $V_{GAIN}$  at 900 MHz

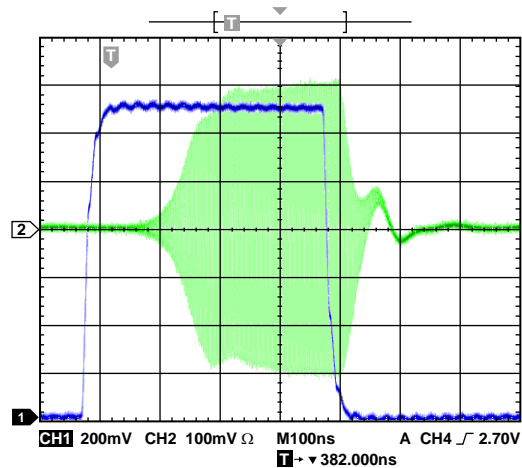

Figure 14. Step Response of Gain Control Input

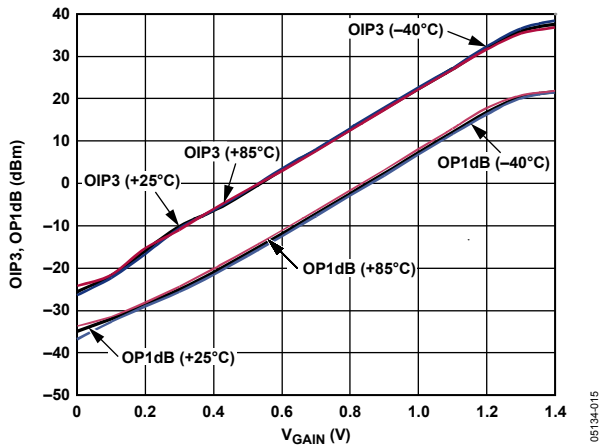

Figure 15. OP1dB and OIP3 vs. Gain over Temperature at 100 MHz

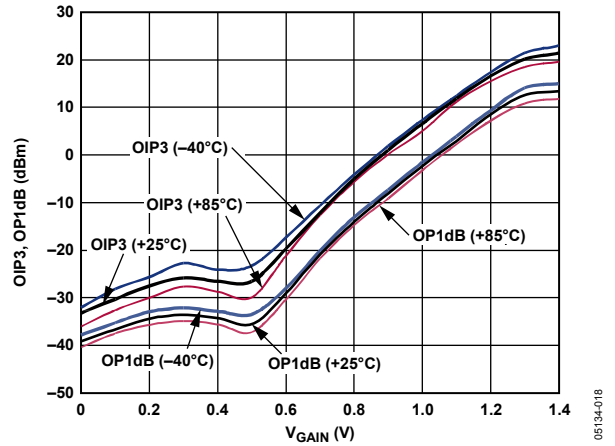

Figure 18. OP1dB and OIP3 vs. Gain over Temperature at 2200 MHz

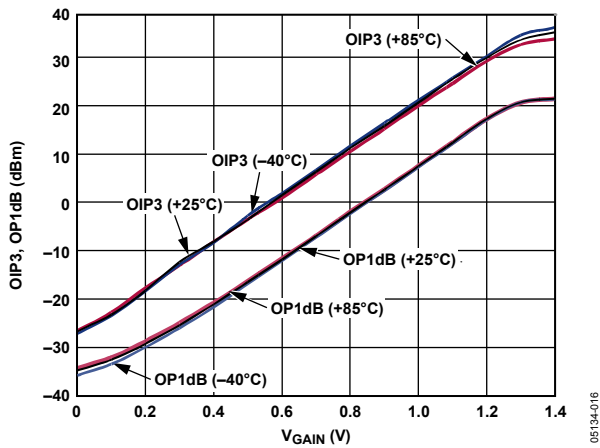

Figure 16. OP1dB and OIP3 vs. Gain over Temperature at 450 MHz

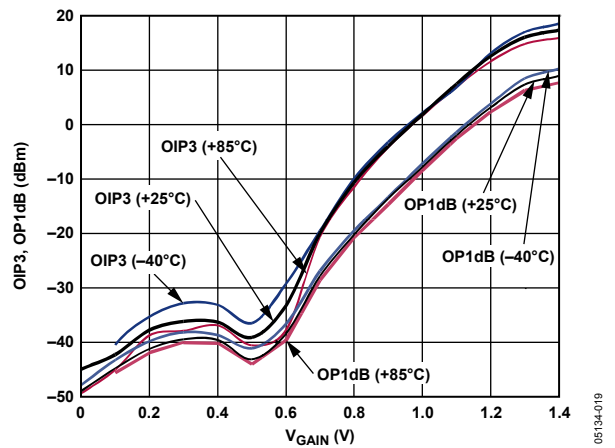

Figure 19. OP1dB and OIP3 vs. Gain over Temperature at 2700 MHz

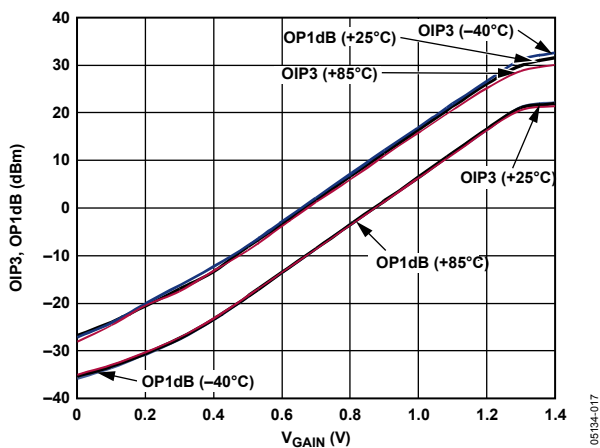

Figure 17. OP1dB and OIP3 vs. Gain over Temperature at 900 MHz

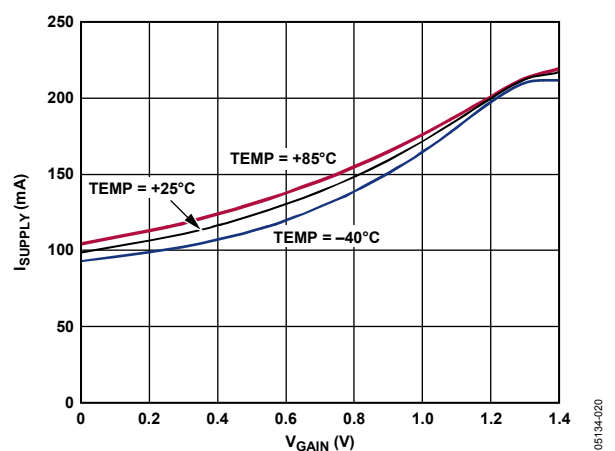

Figure 20. Supply Current vs.  $V_{GAIN}$  and Temperature

05134-015

05134-018

05134-016

05134-019

05134-017

05134-020

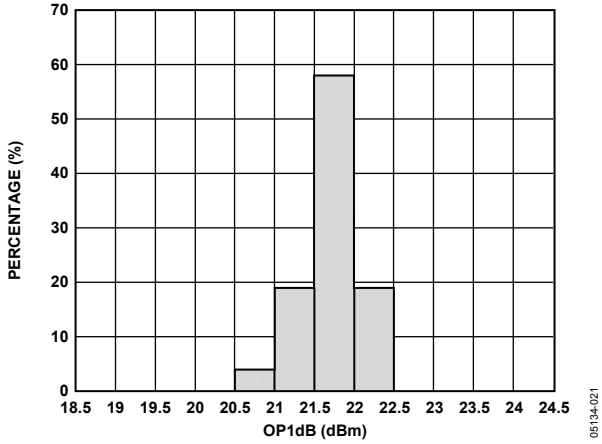

Figure 21. OP1dB Distribution at 900 MHz at Maximum Gain,  $V_{GAIN} = 1.4 V$

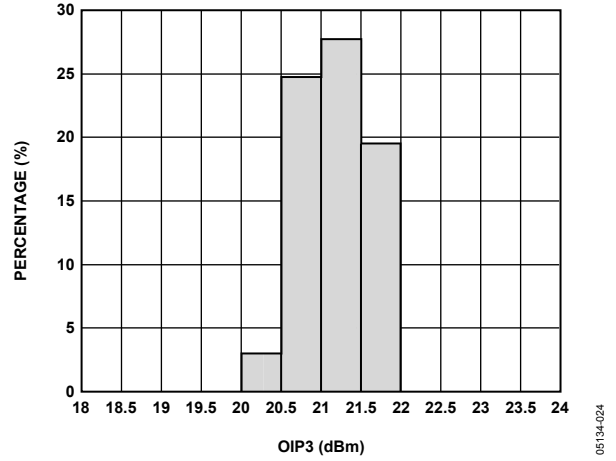

Figure 24. OIP3 Distribution at 2200 MHz at Maximum Gain;  $V_{GAIN} = 1.4 V$

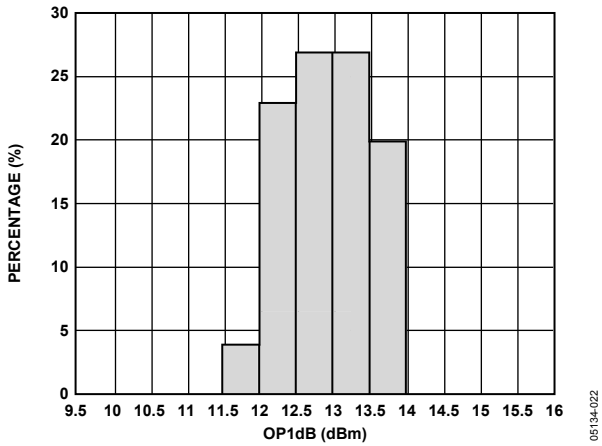

Figure 22. OP1dB Distribution at 2200 MHz at Maximum Gain,  $V_{GAIN} = 1.4 V$

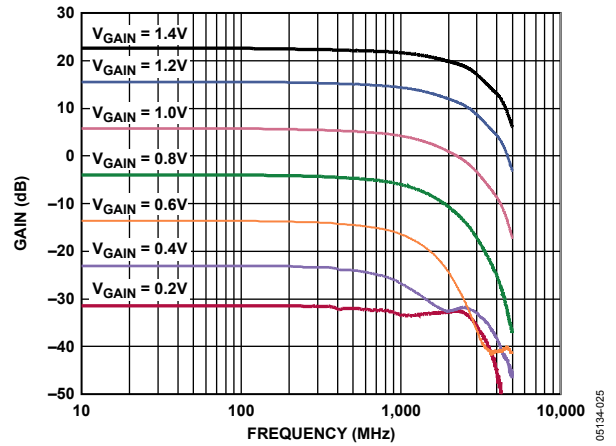

Figure 25. Gain vs. Frequency (Differential)

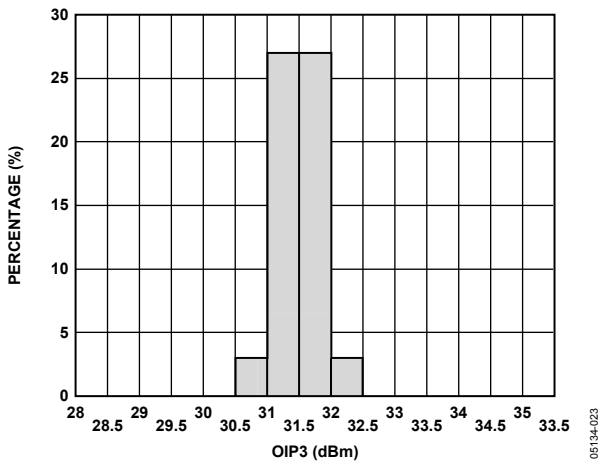

Figure 23. OIP3 Distribution at 900 MHz at Maximum Gain,  $V_{GAIN} = 1.4 V$

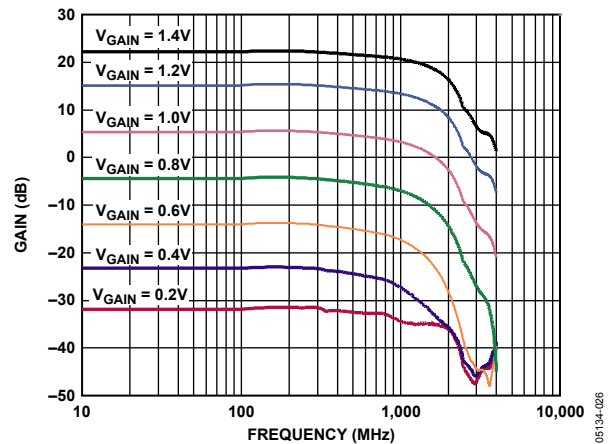

Figure 26. Gain vs. Frequency (Using ETC1-1-13 Baluns)

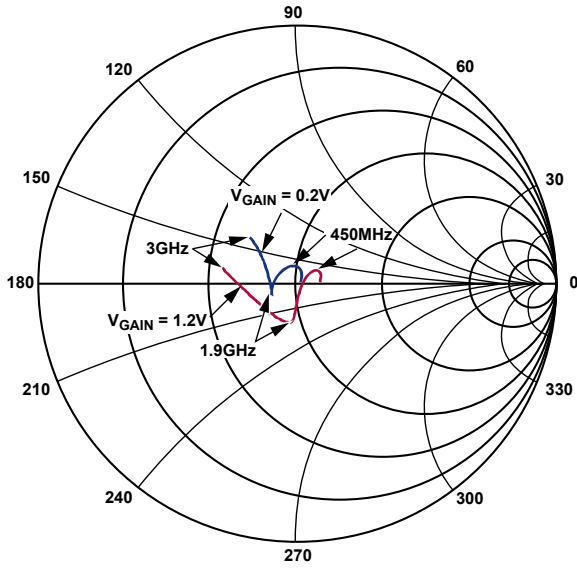

Figure 27. Input Impedance (Differential)

05134-027

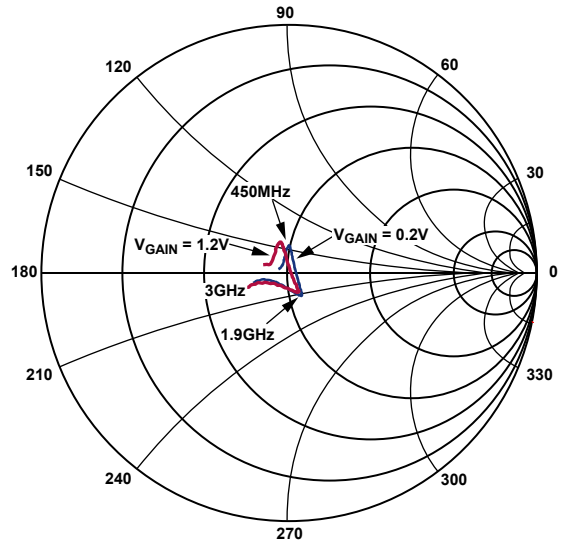

Figure 29. Output Impedance (Differential)

05134-028

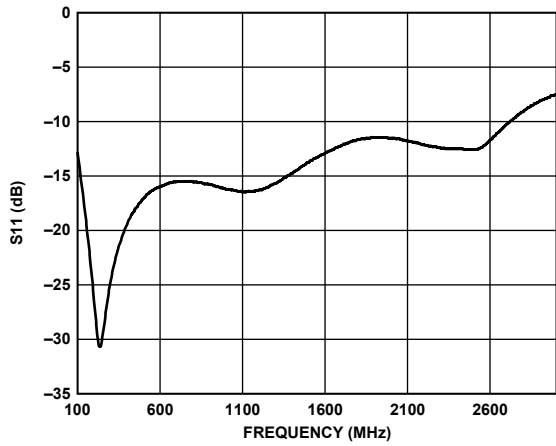

Figure 28. Input Return Loss with ETC1-1-13 Baluns

05134-029

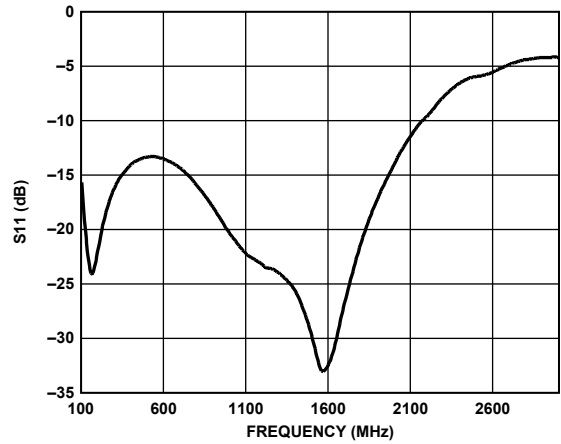

Figure 30. Output Return Loss with ETC1-1-13 Baluns

05134-030

## THEORY OF OPERATION

The ADL5330 is a high performance, voltage controlled variable gain amplifier/attenuator for use in applications with frequencies up to 3 GHz. This device serves as an output variable gain amplifier (OVGA) for applications where a reasonably constant input level is available and the output level adjusts over a wide range. One aspect of an OVGA is the output metrics, OIP3 and OPI1dB, decrease with decreasing gain.

The signal path is fully differential throughout the device in order to provide the usual benefits of differential signaling, including reduced radiation, reduced parasitic feedthrough, and reduced susceptibility to common-mode interference with other circuits. Figure 31 provides a simplified schematic of the ADL5330.

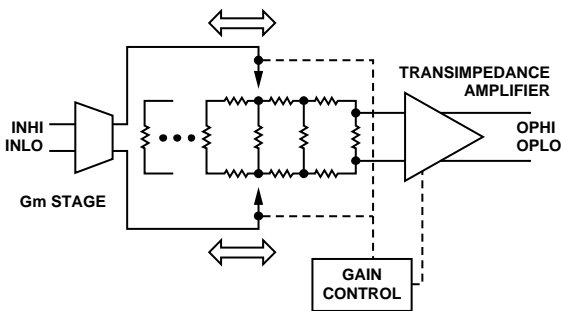

Figure 31. Simplified Schematic

A controlled input impedance of  $50\ \Omega$  is achieved through a combination of passive and active (feedback-derived) termination techniques in an input Gm stage. The input compression point of the Gm stage is 1 dBm to 3 dBm, depending on the input frequency.

Note that the inputs of the Gm stage are internally biased to a dc level, and dc blocking capacitors are generally needed on the inputs to avoid upsetting operation of the device.

The currents from the Gm stage are then injected into a balanced ladder attenuator at a deliberately diffused location along the ladder, wherein the location of the centroid of the injection region is dependent on the applied gain control voltage. The steering of the current injection into the ladder is accomplished

by proprietary means to achieve linear in dB gain control and low distortion.

Linear in dB gain control is accomplished by the application of a voltage in the range of 0 V dc to 1.4 V dc to the gain control pin, with maximum gain occurring at the highest voltage.

The output of the ladder attenuator is passed into a fixed gain transimpedance amplifier (TZA) to provide gain and buffer the ladder terminating impedance from load variations. The TZA uses feedback to improve linearity and to provide controlled  $50\ \Omega$  differential output impedance. The quiescent current of the output amplifier is adaptive; it is slaved to the gain control voltage to conserve power at times when the gain (and output power) are low.

The outputs of the ADL5330 require external dc bias to the positive supply voltage. This bias is typically supplied through external inductors. The outputs are best taken differentially to avoid any common-mode noise that is present, but, if necessary, can be taken single-ended from either output.

If only a single output is used, it is still necessary to provide bias to the unused output pin, and it is advisable to arrange a reasonably equivalent ac load on the unused output. Differential output can be taken via a 1:1 balun into a  $50\ \Omega$  environment. In virtually all cases, it is necessary to use dc blocking in the output signal path.

At high gain settings, the noise floor is set by the input stage, in which case the noise figure (NF) of the device is essentially independent of the gain setting. Below a certain gain setting, however, the input stage noise that reaches the output of the attenuator falls below the input equivalent noise of the output stage. In such a case, the output noise is dominated by the output stage itself; therefore, the overall NF of the device gets worse on a dB per dB basis, because the gain is reduced below the critical value. Figure 9 through Figure 13 provide details of this behavior.

## APPLICATIONS INFORMATION

### BASIC CONNECTIONS

Figure 32 shows the basic connections for operating the ADL5330. There are two positive supplies, VPS1 and VPS2, which must be connected to the same potential. Both COM1 and COM2 (common pins) should be connected to a low impedance ground plane.

A power supply voltage between 4.75 V and 5.25 V should be applied to VPS1 and VPS2. Connect decoupling capacitors with 100 pF and 0.1  $\mu$ F power supplies close to each power supply pin. The VPS2 pins (Pin 18 through Pin 22) can share a pair of decoupling capacitors because of their proximity to each other.

The outputs of the ADL5330, OPHI and OPLO, are open collectors that need to be pulled up to the positive supply with 120 nH RF chokes. The ac coupling capacitors and the RF chokes are the principle limitations for operation at low frequencies. For example, to operate down to 1 MHz, 0.1  $\mu$ F ac coupling capacitors and 1.5  $\mu$ H RF chokes should be used. Note that in some circumstances, the use of substantially larger inductor values results in oscillations.

Since the differential outputs are biased to the positive supply, ac-coupling capacitors, preferably 100 pF, are needed between the ADL5330 outputs and the next stage in the system. Similarly, the INHI and INLO input pins are at bias voltages of about 3.3 V above ground.

The nominal input and output impedance looking into each individual RF input/output pin is 25  $\Omega$ . Consequently, the differential impedance is 50  $\Omega$ .

To enable the ADL5330, the ENBL pin must be pulled high. Taking ENBL low puts the ADL5330 in sleep mode, reducing current consumption to 250  $\mu$ A at ambient. The voltage on ENBL must be greater than 1.7 V to enable the device. When enabled, the device draws 100 mA at low gain to 215 mA at maximum gain.

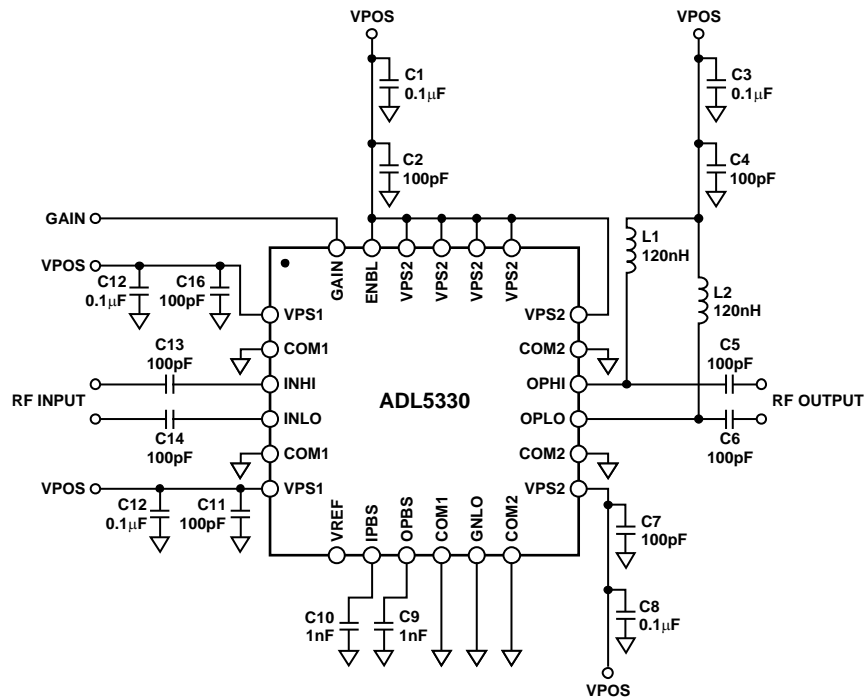

Figure 32. Basic Connections

05334-032

**RF INPUT/OUTPUT INTERFACE**

The ADL5330 is primarily designed for differential signals; however, there are several configurations that can be implemented to interface the ADL5330 to single-ended applications. Figure 33 to Figure 35 show three options for differential to single-ended interfaces. All three configurations use ac-coupling capacitors at the input/output and RF chokes at the output.

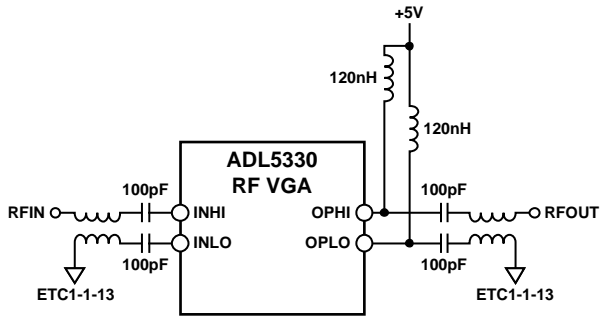

Figure 33. Differential Operation with Balun Transformers

05134-033

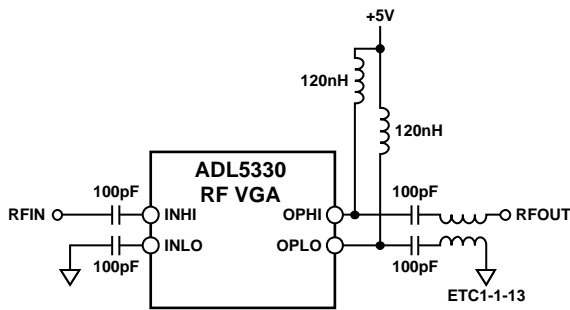

Figure 34. Single-Ended Drive with Balanced Output

05134-041

Figure 33 illustrates differential balance at the input and output using a transformer balun. Input and output baluns are recommended for optimal performance. Much of the characterization for the ADL5330 was completed using 1:1 baluns at the input and output for single-ended 50 Ω match. Operation using M/A-COM ETC1-1-13 transmission line transformer baluns is recommended for a broadband interface; however, narrow-

band baluns can be used for applications requiring lower insertion loss over smaller bandwidths.

The device can be driven single-ended with similar performance, as shown in Figure 34. The single-ended input interface can be implemented by driving one of the input terminals and terminating the unused input to ground. To achieve the optimal performance, the output must remain balanced. In the case of Figure 34, a transformer balun is used at the output.

As an alternative to transformer baluns, lumped element baluns comprised of passive L and C components can be designed at specific frequencies. Figure 35 illustrates differential balance at the input and output of the ADL5330 using discrete lumped element baluns. The lumped element baluns present 180° of phase difference while also providing impedance transformation from source to load, and vice versa. Table 4 lists recommended passive values for various center frequencies with single-ended impedances of 50 Ω. Agilent’s free AppCAD™ program allows for simple calculation of passive components for lumped element baluns.

The lumped element baluns offer ±0.5 dB flatness across 50 MHz for 900 MHz and 2200 MHz. At 2.7 GHz, the frequency band is limited by stray capacitances that dominate the passive components in the lumped element balun at these high frequencies. Therefore, PCB parasitics must be considered during lumped element balun design and board layout.

**Table 4. Recommended Passive Values for Lumped Element Balun, 50 Ω Impedance Match**

Center Frequency	Input			Output		
	C <sub>i</sub>	L <sub>i</sub>	C <sub>ip</sub>	C <sub>o</sub>	L <sub>o</sub>	C <sub>op</sub>
100 MHz	27 pF	82 nH	1 pF	33 pF	72 nH	3.3 pF
900 MHz	3.3 pF	9 nH		3.9 pF	8.7 nH	0.5 pF
2.2 GHz	1.5 pF	3.3 nH	16 nH	1.5 pF	3.6 nH	27 nH
2.7 GHz	1.5 pF	2.4 nH		1.3 pF	2.7 nH	33 nH

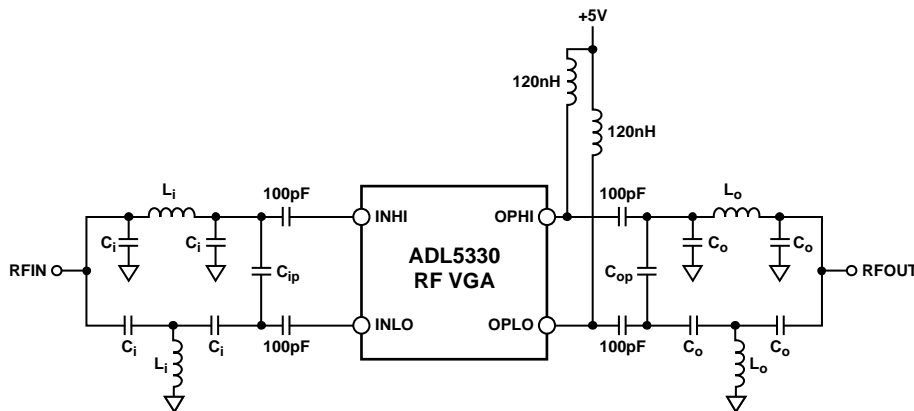

Figure 35. Differential Operation with Discrete LC Baluns

05134-035



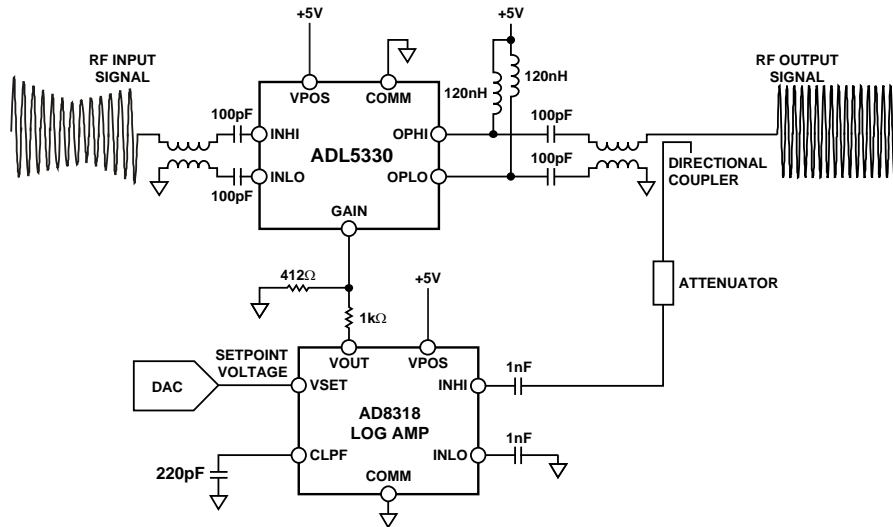

Figure 37. ADL5330 Operating in an Automatic Gain Control Loop in Combination with the AD8318

Figure 38 shows the transfer function of the output power vs. the VSET voltage over temperature for a 900 MHz sine wave with an input power of  $-1.5$  dBm. Note that the power control of the AD8318 has a negative sense. Decreasing VSET, which corresponds to demanding a higher signal from the ADL5330, tends to increase GAIN.

The AGC loop is capable of controlling signals just under the full 60 dB gain control range of the ADL5330. The performance over temperature is most accurate over the highest power range, where it is generally most critical. Across the top 40 dB range of output power, the linear conformance error is well within  $\pm 0.5$  dB over temperature.

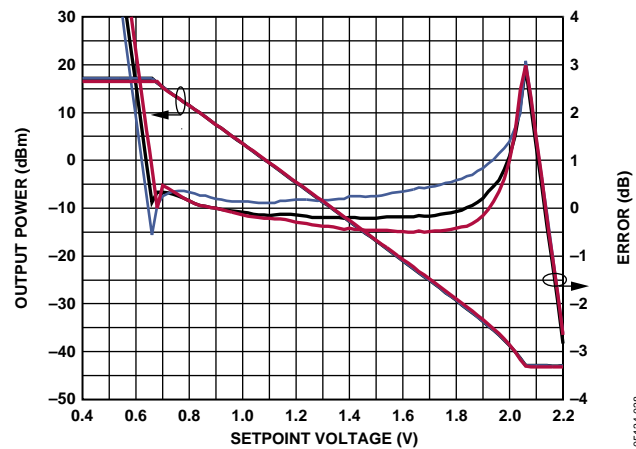

Figure 38. ADL5330 Output Power vs. AD8318 Setpoint Voltage,  $P_{IN} = -1.5$  dBm

The broadband noise added by the logarithmic amplifier is negligible.

In order for the AGC loop to remain in equilibrium, the AD8318 must track the envelope of the ADL5330 output signal and provide the necessary voltage levels to the ADL5330's gain control input. Figure 39 shows an oscilloscope screenshot of the AGC loop depicted in Figure 37. A 100 MHz sine wave with 50% AM modulation is applied to the ADL5330. The output signal from the ADL5330 is a constant envelope sine wave with amplitude corresponding to a setpoint voltage at the AD8318 of 1.5 V. Also shown is the gain control response of the AD8318 to the changing input envelope.

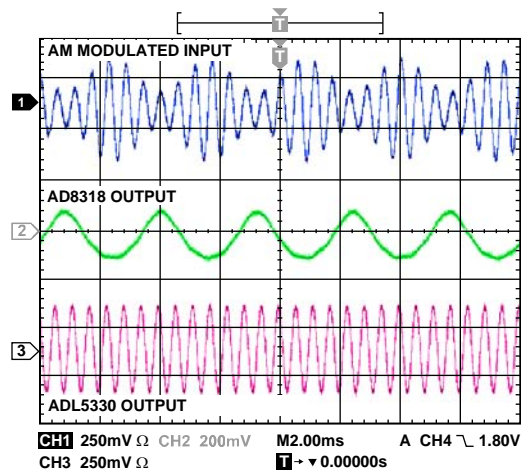

Figure 39. Oscilloscope Screenshot Showing an AM Modulated Input Signal

Figure 40 shows the response of the AGC RF output to a pulse on VSET. As VSET decreases to 1 V, the AGC loop responds with an RF burst. Response time and the amount of signal integration are controlled by the capacitance at the AD8318 C<sub>FLT</sub> pin—a function analogous to the feedback capacitor around an integrating amplifier. An increase in the capacitance results in slower response time.

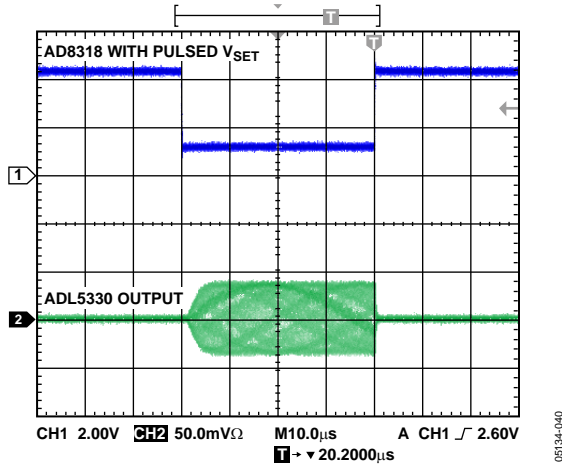

Figure 40. Oscilloscope Screenshot Showing the Response Time of the AGC Loop

More information on the use of AD8318 in an AGC application can be found in the AD8318 data sheet.

### INTERFACING TO AN IQ MODULATOR

The basic connections for interfacing the AD8349 with the ADL5330 are shown in Figure 42. The AD8349 is an RF quadrature modulator with an output frequency range of 700 MHz to 2.7 GHz. It offers excellent phase accuracy and amplitude balance, enabling high performance direct RF modulation for communication systems.

The output of the AD8349 is designed to drive 50 Ω loads and easily interfaces with the ADL5330. The input to the ADL5330

can be driven single-ended, as shown in Figure 42. Similar configurations are possible with the AD8345 (250 MHz to 1 GHz) and AD8346 (800 MHz to 2.5 GHz) quadrature modulators.

Figure 41 shows how output power, EVM, ACPR, and noise vary with the gain control voltage. V<sub>GAIN</sub> is varied from 0 V to 1.4 V. Figure 41 shows that the modulation generated by the AD8349 is a 1 GHz 64 QAM waveform with a 1 MHz symbol rate. The ACPR values are measured in 1 MHz bandwidths at 1.1 MHz and 2.2 MHz carrier offsets. Noise floor is measured at a 20 MHz carrier offset.

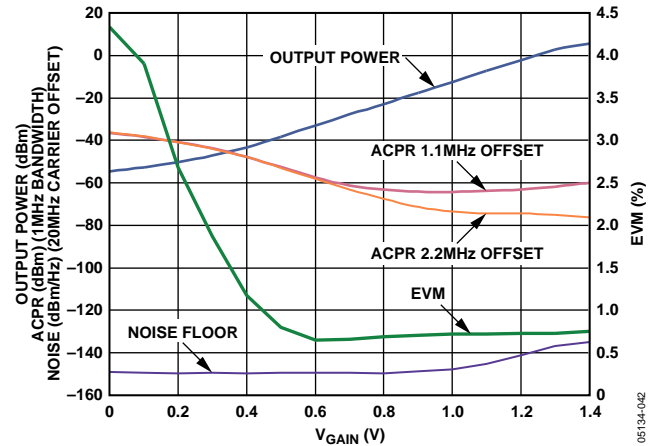

Figure 41. AD8349 and ADL5330 Output Power, ACPR, EVM, and Noise vs. V<sub>GAIN</sub> for a 1 GHz 64 QAM Waveform with 1 MHz Symbol Rate

The output of the AD8349 driving the ADL5330 should be limited to the range that provides the optimal EVM and ACPR performance. The power range is found by sweeping the output power of the AD8349 to find the best compromise between EVM and ACPR of the system. In Figure 41, the AD8349 output power is set to -15 dBm.

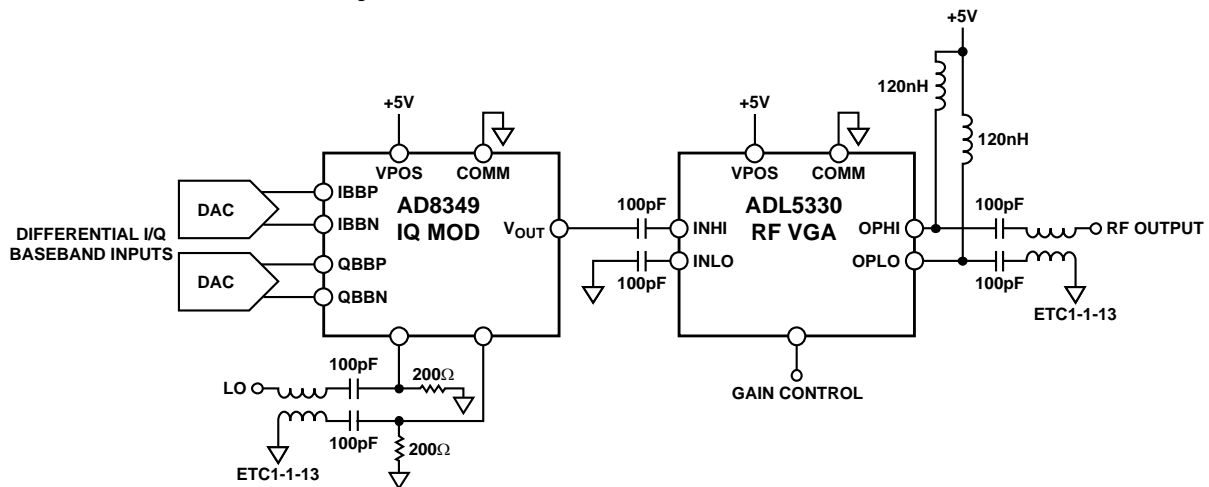

Figure 42. AD8349 Quadrature Modulator and ADL5330 Interface

WCDMA TRANSMIT APPLICATION

Figure 43 shows a plot of the output spectrum of the ADL5330 transmitting a single-carrier WCDMA signal (Test Model 1-64 at 2140 MHz). The carrier power output is approximately -9.6 dBm. The gain control voltage is equal to 1.4 V giving a gain of approximately 14.4 dB. At this power level, an adjacent channel power ratio of -65.61 dBc is achieved. The alternate channel power ratio of -71.37 dBc is dominated by the noise floor of the ADL5330.

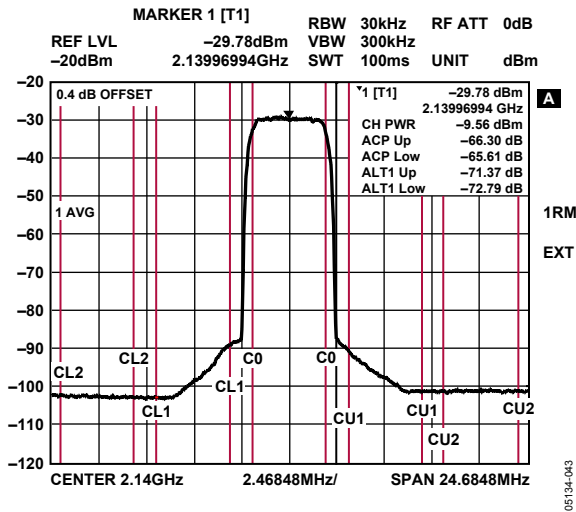

Figure 43. Single-Carrier WCDMA Spectrum at 2140 MHz;  $V_{GAIN} = 1.4 V, P_{IN} = -23 dBm$

Figure 44 shows how ACPR and noise vary with different input power levels (gain control voltage is held at 1.4 V). At high power levels, both adjacent and alternate channel power ratios sharply increase. As output power drops, adjacent and alternate channel power ratios both reach minima before the measurement becomes dominated by the noise floor of the ADL5330. At this point, adjacent and alternate channel power ratios become approximately equal.

As the output power drops, the noise floor, measured in dBm/Hz at 50 MHz carrier offset, initially falls and then levels off.

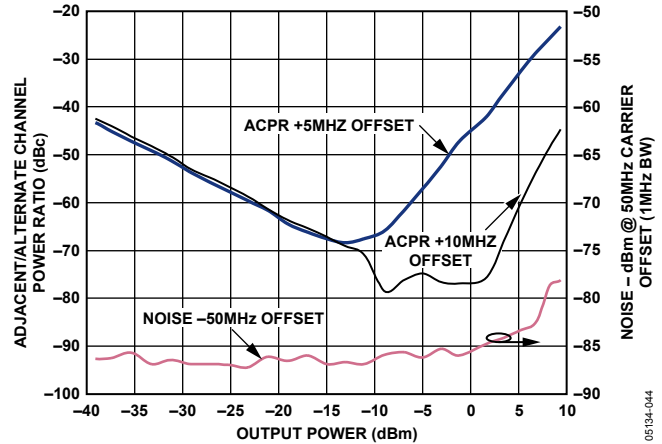

Figure 44. ACPR and Noise vs. Output Power; Single-Carrier WCDMA Input (Test Model 1-64 at 2140 MHz),  $V_{GAIN} = 1.4 V$  (Fixed)

Figure 45 shows how output power, ACPR, and noise vary with the gain control voltage.  $V_{GAIN}$  is varied from 0 V to 1.4 V and input power is held constant at -19 dBm.

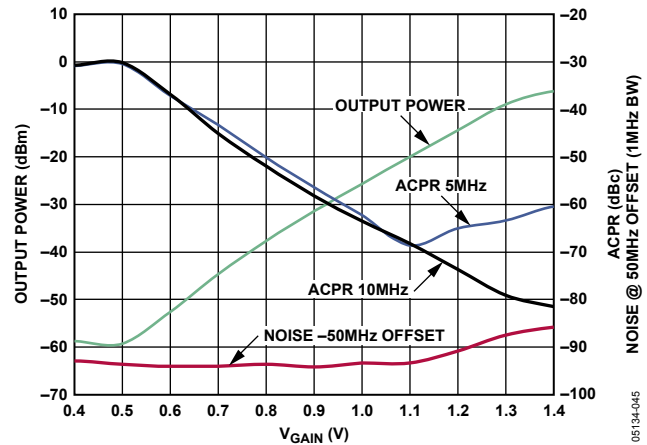

Figure 45. Output Power, ACPR, and Noise vs.  $V_{GAIN}$ ; Single-Carrier WCDMA (Test Model 1-64 at 2140 MHz) Input at -19 dBm

**CDMA2000 TRANSMIT APPLICATION**

To test the compliance to the CDMA2000 base station standard, an 880 MHz, three-carrier CDMA2000 test model signal (forward pilot, sync, paging, and six traffic, as per 3GPP2 C.S0010-B, Table 6.5.2.1) was applied to the ADL5330. A cavity-tuned filter with a 4.6 MHz pass band was used to reduce noise from the signal source being applied to the device.

Figure 46 shows the spectrum of the output signal under nominal conditions. Total P<sub>OUT</sub> of the three-carrier signal is equal to 0.46 dBm and V<sub>GAIN</sub> = 1.4 V. Adjacent and alternate channel power ratio is measured in a 30 kHz bandwidth at 750 kHz and 1.98 MHz carrier offset, respectively.

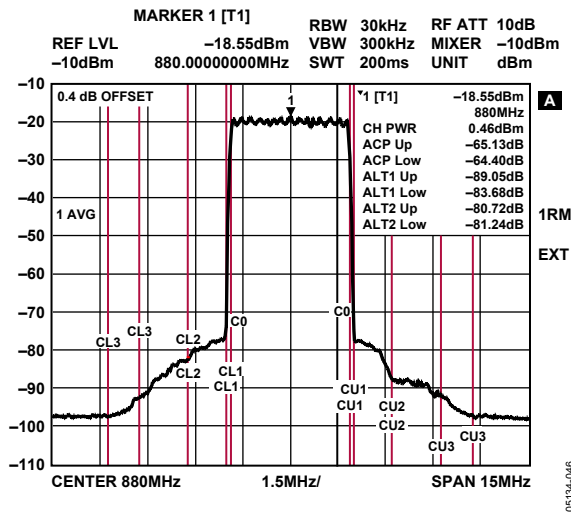

Figure 46. 880 MHz Output Spectrum, Three-Carrier CDMA2000 Test Model at -23 dBm Total Input Power, V<sub>GAIN</sub> = 1.4 V, ACPR Measured at 750 kHz and 1.98 MHz Carrier Offset, Input Signal Filtered Using a Cavity Tuned Filter (Pass Band = 4.6 MHz)

In testing, by holding the gain control voltage steady at 1.4 V, input power was swept. Figure 47 shows ACPR and noise floor vs. total output power. Noise floor is measured at 1 MHz bandwidth at 4 MHz carrier offset.

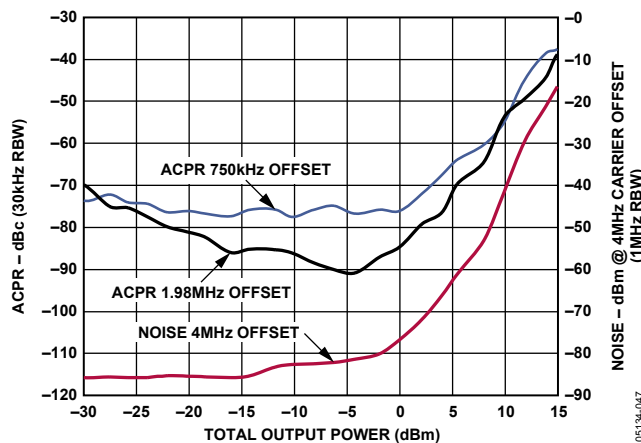

Figure 47. ACPR vs. Total Output Power, 880 MHz Three-Carrier CDMA2000 Test Model; V<sub>GAIN</sub> = 1.4 V (Fixed), ACPR Measured in 30 kHz Bandwidth at 750 kHz and 1.98 MHz Carrier Offset

The results show that up to a total output power of +8 dBm, ACPR remains in compliance with the standard (<-45 dBc at 750 kHz and <-60 dBc at 1.98 MHz). At low output power levels, ACPR at 1.98 MHz carrier offset degrades as the noise floor of the ADL5330 becomes the dominant contributor to measured ACPR. Measured noise at 4 MHz carrier offset begins to increase sharply above 0 dBm output power. This increase is not due to noise but results from increased carrier-induced distortion. As output power drops below 0 dBm total, the noise floor drops towards -85 dBm.

With a fixed input power of -23 dBm, the output power was again swept by exercising the gain control input. V<sub>GAIN</sub> was swept from 0 V to 1.4 V. The resulting total output power, ACPR, and noise floor are shown in Figure 48.

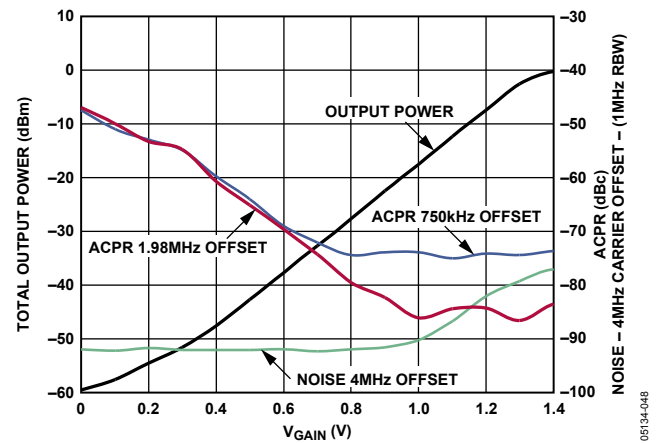

Figure 48. Total Output Power and ACPR vs. V<sub>GAIN</sub>, 880 MHz Three-Carrier CDMA2000 Test Model at -23 dBm Total Input Power; ACPR Measured in 30 kHz Bandwidth at 750 kHz and 1.98 MHz Carrier Offset

Above V<sub>GAIN</sub> = 0.4 V, the ACPR is still in compliance with the standard. As the gain control input drops below 1.0 V, the noise floor drops below -90 dBm.

**SOLDERING INFORMATION**

On the underside of the chip scale package, there is an exposed compressed paddle. This paddle is internally connected to the chip's ground. Solder the paddle to the low impedance ground plane on the printed circuit board to ensure specified electrical performance and to provide thermal relief. It is also recommended that the ground planes on all layers under the paddle be stitched together with vias to reduce thermal impedance.

## EVALUATION BOARD

Figure 49 shows the schematic of the ADL5330 evaluation board. The silkscreen and layout of the component and circuit sides are shown in Figure 50 through Figure 53. The board is powered by a single-supply in the 4.75 V to 5.25 V range. The power supply is decoupled by 100 pF and 0.1  $\mu$ F capacitors at each power supply pin. Additional decoupling, in the form of a series resistor or inductor at the supply pins, can also be added. Table 5 details the various configuration options of the evaluation board.

The output pins of the ADL5330 require supply biasing with 120 nH RF chokes. Both the input and output pins have 50  $\Omega$  differential impedances and must be ac-coupled. These pins are converted to single-ended with a pair of baluns (M/A-COM part number ETC1-1-13).

Instead of using balun transformers, lumped-element baluns comprising passive L and C components can be designed. Alternate input and output RF paths with component pads are available on the circuit side of the board. Components M1

through M9 are used for the input interface, and M10 through M18 are used for the output interface. DC blocking capacitors of 100 pF must be installed in C15 and C16 for the input and C17 and C18 for the output. The C5, C6, C11, and C12 capacitors must be removed. An alternate set of SMA connectors, INPUT2 and OUT2, are used for this configuration.

The ADL5330 can be driven single-ended; use the RF input path on the circuit side of the board. A set of 100 pF dc blocking capacitors must be installed in C15 and C16. C5 and C6 must be removed. Use the INPUT2 SMA to drive one of the differential input pins. The unused pin should be terminated to ground, as shown in Figure 34.

The ADL5330 is enabled by applying a logic high voltage to the ENBL pin by placing a jumper across the SW1 header in the O position. Remove the jumper for disable. This pulls the ENBL pin to ground through the 10 k $\Omega$  resistor.

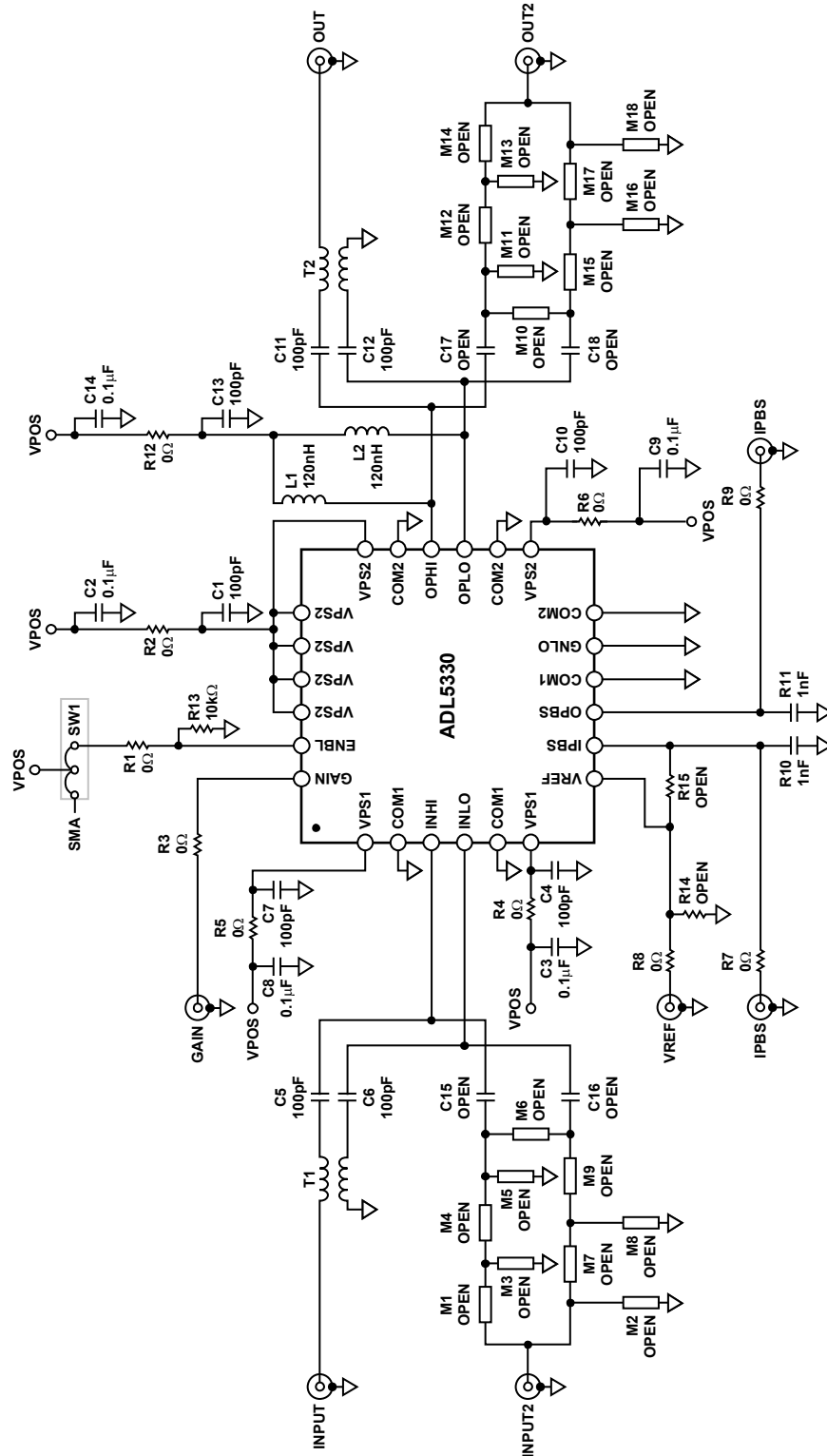

Figure 49. Evaluation Board Schematic

05134-049

Table 5. Evaluation Board Configuration Options

Components	Function	Default Conditions
C1 to C4, C7 to C10, C13, C14, R2, R4, R5, R6, R12	Power Supply Decoupling. The nominal supply decoupling consists of 100 pF and 0.1 $\mu$ F capacitors at each power supply pin (the VPS2 pins, Pin 18 to Pin 22, share a pair of decoupling capacitors because of their proximity). A series inductor or small resistor can be placed between the capacitors for additional decoupling.	C1, C4, C7, C10, C13 = 100 pF (size 0603) C2, C3, C8, C9, C14 = 0.1 $\mu$ F (size 0603) R2, R4, R5, R6, R12 = 0 $\Omega$ (size 0402)
T1, C5, C6	Input Interface. The 1:1 balun transformer T1 converts a 50 $\Omega$ single-ended input to the 50 $\Omega$ differential input. C5 and C6 are dc blocks.	T1 = ETC1-1-13 (M/A-COM) C5, C6 = 100 pF (size 0603)
T2, C11, C12, L1, L2	Output Interface. The 1:1 balun transformer T2 converts the 50 $\Omega$ differential output to 50 $\Omega$ single-ended output. C11 and C2 are dc blocks. L3 and L4 provide dc biases for the output.	T2 = ETC1-1-13 (M/A-COM) C11, C12 = 100 pF (size 0603) L1, L2 = 120 nH (size 0805)
SW1, R1, R13	Enable Interface. The ADL5330 is enabled by applying a logic high voltage to the ENBL pin by placing a jumper across SW1 to the O position. Remove the jumper for disable. To exercise the enable function by applying an external high or low voltage, use the pin labeled O on the SW1 header.	SW1 = installed R1 = 0 $\Omega$ (size 0402) R13 = 10 k $\Omega$ (size 0402)
C15 to C18, M1 to M18	Alternate Input/Output Interface. The circuit side of the evaluation board offers an alternate RF input and output interface. A lumped-element balun can be built using L and C components instead of using the balun transformer (see the Applications Information section). The components, M1 through M9, are used for the input, and M10 through M18 are used for the output. To use the alternate RF paths, disconnect the dc blocking capacitors (Capacitor C5 and Capacitor C6 for the input and Capacitor C11 and Capacitor C12 for the output). Place 100 pF dc blocking capacitors on C15, C16, C17, and C18. Use the alternate set of SMA connectors, INPUT2 and OUT2.	M1 to M18 = not installed (size 0603) C15 to C18 = not installed (size 0603)

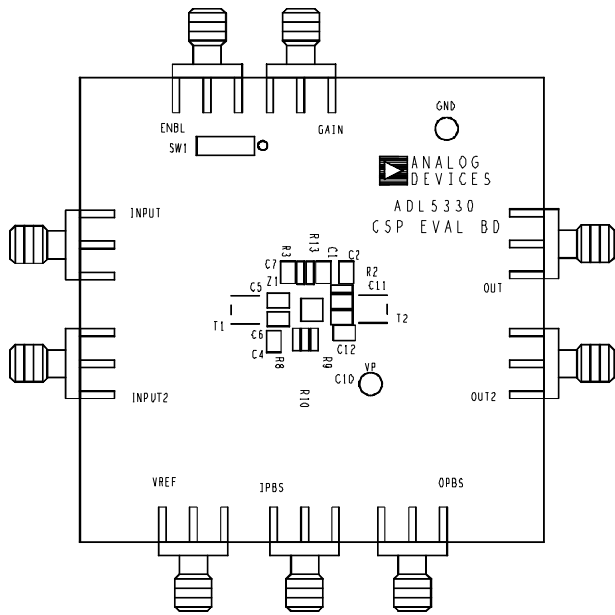

Figure 50. Component Side Silkscreen

05134-051

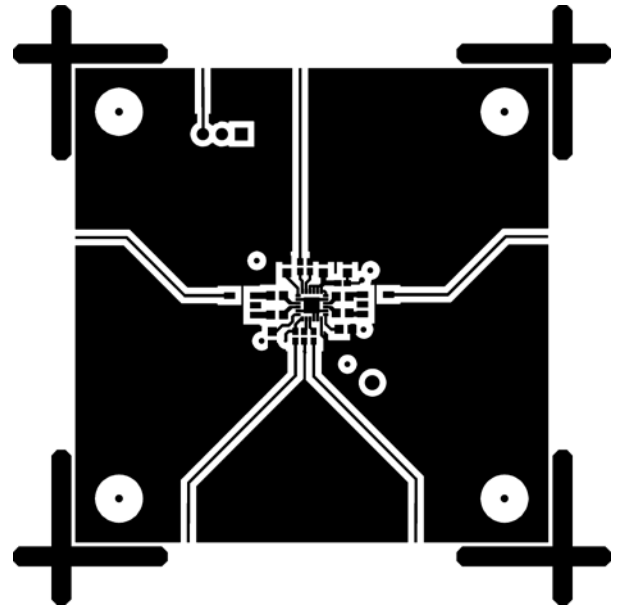

Figure 52. Component Side Layout

05134-053

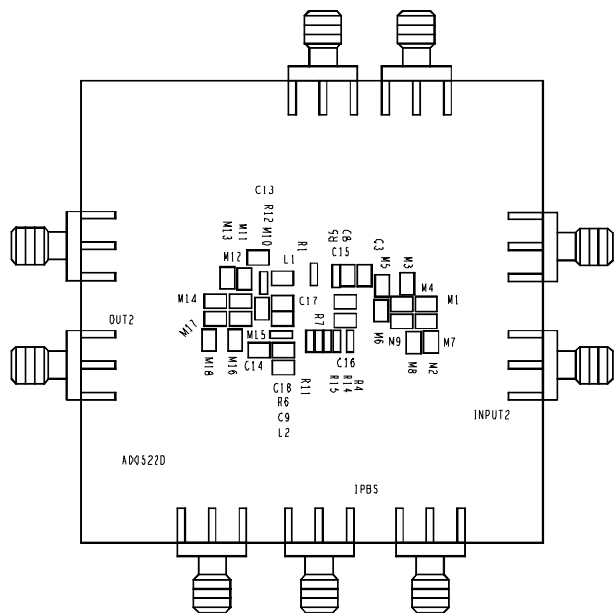

Figure 51. Circuit Side Silkscreen

05134-050

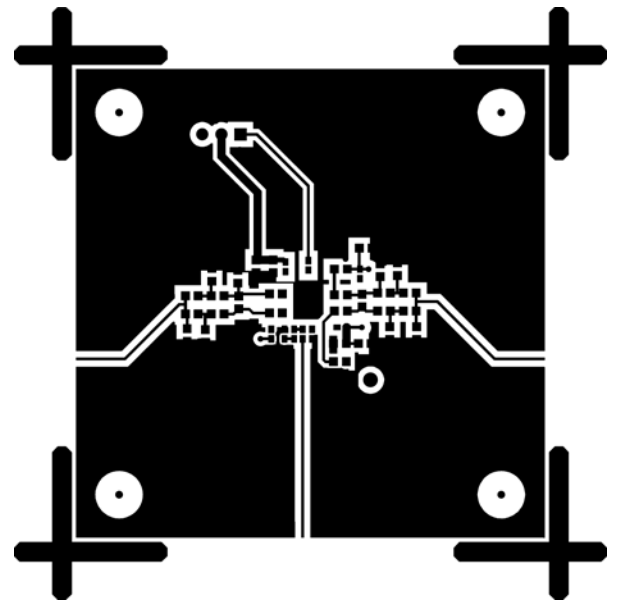
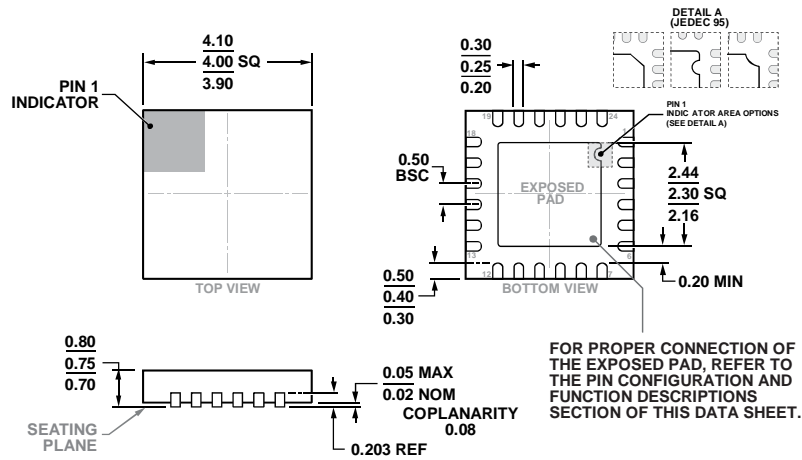

Figure 53. Circuit Side Layout

05134-052

OUTLINE DIMENSIONS



COMPLIANT TO JEDEC STANDARDS MO-220-WGGD-8  
 Figure 54. 24-Lead Lead Frame Chip Scale Package [LFCSP]  
 4 mm × 4 mm Body and 0.75 mm Package Height  
 (CP-24-14)  
 Dimensions shown in millimeters

ORDERING GUIDE

Model <sup>1,2</sup>	Temperature Range	Package Description	Package Option	Ordering Quantity
ADL5330ACPZ-WP	-40°C to +85°C	24-Lead Lead Frame Chip Scale Package [LFCSP]	CP-24-14	64
ADL5330ACPZ-REEL7	-40°C to +85°C	24-Lead Lead Frame Chip Scale Package [LFCSP]	CP-24-14	1,500
ADL5330ACPZ-R2	-40°C to +85°C	24-Lead Lead Frame Chip Scale Package [LFCSP]	CP-24-14	250
ADL5330-EVAL		Evaluation Board		

<sup>1</sup> Z = RoHS Compliant Part.  
<sup>2</sup> WP = waffle pack.

## Looking for pricing, stock, or lifecycle information?

Click below to explore more details on WIN SOURCE:

 [View ADL5330ACPZ-R2 on WIN SOURCE](#)

 [Analog Devices Inc. Information](#)

## Optimize Your Supply Chain with WIN SOURCE Solutions

-  Global Sourcing Solution
-  Obsolete Management
-  Cost Control Management
-  Shortage Management
-  Alternative Solution
-  Excess Inventory Management