



**THE DATASHEET OF
AD6684BCPZ-500**

FEATURES

- JESD204B (Subclass 1) coded serial digital outputs
- Lane rates up to 15 Gbps
- 1.68 W total power at 500 MSPS
- 420 mW per analog-to-digital converter (ADC) channel
- SFDR = 82 dBFS at 305 MHz (1.8 V p-p input range)
- SNR = 66.8 dBFS at 305 MHz (1.8 V p-p input range)
- Noise density = -151.5 dBFS/Hz (1.8 V p-p input range)
- Analog input buffer
- On-chip dithering to improve small signal linearity
- Flexible differential input range
- 1.44 V p-p to 2.16 V p-p (1.80 V p-p nominal)
- 82 dB channel isolation/crosstalk
- 0.975 V, 1.8 V, and 2.5 V dc supply operation
- Noise shaping requantizer (NSR) option for main receiver
- Variable dynamic range (VDR) option for digital predistortion (DPD)

- 4 integrated wideband digital downconverters (DDCs)
- 48-bit numerically controlled oscillator (NCO), up to 4 cascaded half-band filters
- 1.4 GHz analog input full power bandwidth
- Amplitude detect bits for efficient automatic gain control (AGC) implementation
- Differential clock input
- Integer clock divide by 1, 2, 4, or 8
- On-chip temperature diode
- Flexible JESD204B lane configurations

APPLICATIONS

- Communications
- Diversity multiband, multimode digital receivers
- 3G/4G, W-CDMA, GSM, LTE, LTE-A
- HFC digital reverse path receivers
- Digital predistortion observation paths
- General-purpose software radios

FUNCTIONAL BLOCK DIAGRAM

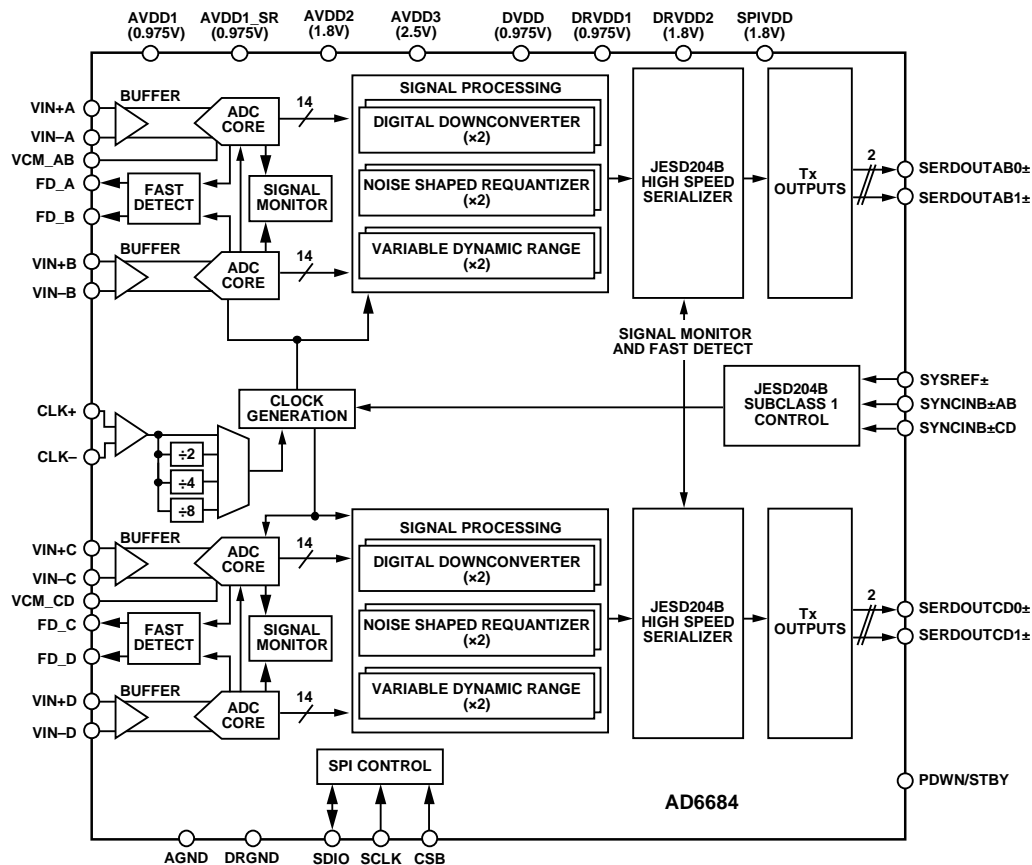

Figure 1.

Rev. A

Document Feedback

Information furnished by Analog Devices is believed to be accurate and reliable. However, no responsibility is assumed by Analog Devices for its use, nor for any infringements of patents or other rights of third parties that may result from its use. Specifications subject to change without notice. No license is granted by implication or otherwise under any patent or patent rights of Analog Devices. Trademarks and registered trademarks are the property of their respective owners.

TABLE OF CONTENTS

Features	1	DDC Gain Stage	44
Applications	1	DDC Complex to Real Conversion	44
Functional Block Diagram	1	DDC Example Configurations	45
Revision History	3	Noise Shaping Requantizer (NSR)	49
General Description	4	Decimating Half-Band Filter	49
Product Highlights	4	NSR Overview	50
Specifications.....	5	Variable Dynamic Range (VDR).....	51
DC Specifications	5	VDR Real Mode.....	52
AC Specifications.....	6	VDR Complex Mode	52
Digital Specifications	8	Digital Outputs	54
Switching Specifications	9	Introduction to the JESD204B Interface	54
Timing Specifications	9	JESD204B Overview	54
Absolute Maximum Ratings.....	11	Functional Overview	56
Thermal Characteristics	11	JESD204B Link Establishment	56
ESD Caution.....	11	Physical Layer (Driver) Outputs	57
Pin Configuration and Function Descriptions.....	12	JESD204B Tx Converter Mapping.....	59
Typical Performance Characteristics	14	Setting Up the AD6684 Digital Interface	60
Equivalent Circuits	21	Latency.....	64
Theory of Operation	23	End-To-End Total Latency.....	64
ADC Architecture	23	Multichip Synchronization.....	65
Analog Input Considerations.....	23	SYSREF± Setup/Hold Window Monitor.....	67
Voltage Reference	25	Test Modes.....	69
Clock Input Considerations	26	ADC Test Modes	69
Temperature Diode	27	JESD204B Block Test Modes	70
ADC Overrange and Fast Detect.....	28	Serial Port Interface.....	72
ADC Overrange.....	28	Configuration Using the SPI.....	72
Fast Threshold Detection (FD_A, FD_B, FD_C and FD_D)....	28	Hardware Interface.....	72
Signal Monitor	29	SPI Accessible Features.....	72
SPORT Over JESD204B.....	29	Memory Map	73
Digital Downconverter (DDC).....	32	Reading the Memory Map Register Table.....	73
DDC I/Q Input Selection	32	Memory Map	74
DDC I/Q Output Selection	32	Memory Map Details	74
DDC General Description	32	Applications Information	98
Frequency Translation	38	Power Supply Recommendations.....	98
General Description	38	Exposed Pad Thermal Heat Slug Recommendations.....	98
DDC NCO + Mixer Loss and SFDR.....	39	AVDD1_SR (Pin 64) and AGND_SR (Pin 63 and Pin 67)...	98
Numerically Controlled Oscillator.....	39	Outline Dimensions	99
FIR Filters	41	Ordering Guide	99
General Description	41		
Half-Band Filters	42		

REVISION HISTORY**4/2020—Rev. 0 to Rev. A**

Change to Unit Interval (UI) Parameter, Table 4 and Data Rate per Channel (NRZ) Parameter, Table 4.....	9
Changes to De-Emphasis Section	58
Added Table 33; Renumbered Sequentially and Figure 94; Renumbered Sequentially	58
Changes to Setting Up the AD6684 Digital Interface Section ..	60
Changes to Example 1: ADC with DDC Option (Two ADCs Plus Two DDCs in Each Pair) Section	62
Changes to Figure 104	67
Changes to Reading the Memory Map Register Table Section	73
Deleted Memory Map Summary Section and Table 45; Renumbered Sequentially	74
Changes to Register 0x05B0 Row, Table 46	94
Added Register 0x05C1 Rows, Table 46.....	95
Changes to Register 0x05C4 Row and Register 0x05C6 Row, Table 46.....	95

10/2016—Revision 0: Initial Version

GENERAL DESCRIPTION

The AD6684 is a 135 MHz bandwidth, quad intermediate frequency (IF) receiver. It consists of four 14-bit, 500 MSPS ADCs and various digital processing blocks consisting of four wideband DDCs, an NSR, and VDR monitoring. The device has an on-chip buffer and a sample-and-hold circuit designed for low power, small size, and ease of use. This device is designed to support communications applications. The analog full power bandwidth of the device is 1.4 GHz.

The quad ADC cores feature a multistage, differential pipelined architecture with integrated output error correction logic. Each ADC features wide bandwidth inputs supporting a variety of user-selectable input ranges. An integrated voltage reference eases design considerations. The AD6684 is optimized for wide input bandwidth, excellent linearity, and low power in a small package.

The analog inputs and clock signal input are differential. Each pair of ADC data outputs are internally connected to two DDCs through a crossbar mux. Each DDC consists of up to five cascaded signal processing stages: a 48-bit frequency translator, NCO, and up to four half-band decimation filters.

Each ADC output is connected internally to an NSR block. The integrated NSR circuitry allows improved SNR performance in a smaller frequency band within the Nyquist bandwidth. The device supports two different output modes selectable via the serial port interface (SPI). With the NSR feature enabled, the outputs of the ADCs are processed such that the AD6684 supports enhanced SNR performance within a limited portion of the Nyquist bandwidth while maintaining a 9-bit output resolution.

Each ADC output is also connected internally to a VDR block. This optional mode allows full dynamic range for defined input signals. Inputs that are within a defined mask (based on DPD applications) are passed unaltered. Inputs that violate this defined mask result in the reduction of the output resolution.

With VDR, the dynamic range of the observation receiver is determined by a defined input frequency mask. For signals falling within the mask, the outputs are presented at the maximum resolution allowed. For signals exceeding defined power levels within this frequency mask, the output resolution

is truncated. This mask is based on DPD applications and supports tunable real IF sampling, and zero IF or complex IF receive architectures.

Operation of the AD6684 in the DDC, NSR, and VDR modes is selectable via SPI-programmable profiles (the default mode is NSR at startup).

In addition to the DDC blocks, the AD6684 has several functions that simplify the AGC function in the communications receiver. The programmable threshold detector allows monitoring of the incoming signal power using the fast detect output bits of the ADC. If the input signal level exceeds the programmable threshold, the fast detect indicator goes high. Because this threshold indicator has low latency, the user can quickly turn down the system gain to avoid an overrange condition at the ADC input.

Users can configure each pair of IF receiver outputs onto either one or two lanes of Subclass 1 JESD204B-based high speed serialized outputs, depending on the decimation ratio and the acceptable lane rate of the receiving logic device. Multiple device synchronization is supported through the SYSREF±, SYNCINB±AB, and SYNCINB±CD input pins.

The AD6684 has flexible power-down options that allow significant power savings when desired. All of these features can be programmed using the 1.8 V capable, 3-wire SPI.

The AD6684 is available in a Pb-free, 72-lead LFCSP and is specified over the -40°C to +105°C junction temperature range.

This product may be protected by one or more U.S. or international patents

PRODUCT HIGHLIGHTS

1. Low power consumption per channel.
2. JESD204B lane rate support up to 15 Gbps.
3. Wide full power bandwidth supports IF sampling of signals up to 1.4 GHz.
4. Buffered inputs ease filter design and implementation.
5. Four integrated wideband decimation filters and NCO blocks supporting multiband receivers.
6. Programmable fast overrange detection.
7. On-chip temperature diode for system thermal management.

SPECIFICATIONS

DC SPECIFICATIONS

AVDD1 = 0.975 V, AVDD1_SR = 0.975 V, AVDD2 = 1.8 V, AVDD3 = 2.5 V, DVDD = 0.975 V, DRVDD1 = 0.975 V, DRVDD2 = 1.8 V, SPIVDD = 1.8 V, specified maximum sampling rate, clock divider = 4, 1.8 V p-p full-scale differential input, 0.5 V internal reference, $A_{IN} = -1.0$ dBFS, default SPI settings, unless otherwise noted. Minimum and maximum specifications are guaranteed for the full operating T_J range of -40°C to $+105^{\circ}\text{C}$. Typical specifications represent performance at $T_J = 50^{\circ}\text{C}$ ($T_A = 25^{\circ}\text{C}$).

Table 1.

Parameter	Min	Typ	Max	Unit
RESOLUTION	14			Bits
ACCURACY		Guaranteed		
No Missing Codes		0		% FSR
Offset Error		0		% FSR
Gain Error	-5.0		+5.0	% FSR
Gain Matching		1.0		% FSR
Differential Nonlinearity (DNL)	-0.7	± 0.4	+0.7	LSB
Integral Nonlinearity (INL)	-5.1	± 1.0	+5.1	LSB
TEMPERATURE DRIFT				
Offset Error		8		ppm/ $^{\circ}\text{C}$
Gain Error		214		ppm/ $^{\circ}\text{C}$
INTERNAL VOLTAGE REFERENCE				
Voltage		0.5		V
INPUT REFERRED NOISE		2.6		LSB rms
ANALOG INPUTS				
Differential Input Voltage Range (Programmable)	1.44	1.80	2.16	V p-p
Common-Mode Voltage (V_{CM})		1.34		V
Differential Input Capacitance		1.75		pF
Differential Input Resistance		200		Ω
Analog Input Full Power Bandwidth		1.4		GHz
POWER SUPPLY ¹				
AVDD1	0.95	0.975	1.00	V
AVDD1_SR	0.95	0.975	1.00	V
AVDD2	1.71	1.8	1.89	V
AVDD3	2.44	2.5	2.56	V
DVDD	0.95	0.975	1.00	V
DRVDD1	0.95	0.975	1.00	V
DRVDD2	1.71	1.8	1.89	V
SPIVDD	1.71	1.8	1.89	V
I_{AVDD1}		319	482	mA
I_{AVDD1_SR}		21	53	mA
I_{AVDD2}		438	473	mA
I_{AVDD3}		87	103	mA
I_{DVDD} ²		145	198	mA
I_{DRVDD1}		162	207	mA
I_{DRVDD2}		23	29	mA
I_{SPIVDD}		1	1.6	mA
POWER CONSUMPTION				
Total Power Dissipation (Including Output Drivers) ²		1.68	1.94	W
Power-Down Dissipation		325		mW
Standby ³		1.20		W

¹ Power is measured at NSR, 28% bandwidth, L, M, and F = 222.

² Default mode, no decimation enabled. For each link, L = 2, M = 2, and F = 2.

³ Standby mode is controlled by the SPI.

AC SPECIFICATIONS

AVDD1 = 0.975 V, AVDD1_SR = 0.975 V, AVDD2 = 1.8 V, AVDD3 = 2.5 V, DVDD = 0.975 V, DRVDD1 = 0.975 V, DRVDD2 = 1.8 V, SPIVDD = 1.8 V, specified maximum sampling rate, clock divider = 4, 1.8 V p-p full-scale differential input, 0.5 V internal reference, $A_{IN} = -1.0$ dBFS, default SPI settings, VDR mode (input mask not triggered), unless otherwise noted. Minimum and maximum specifications are guaranteed for the full operating junction temperature (T_J) range of -40°C to $+105^{\circ}\text{C}$. Typical specifications represent performance at $T_J = 50^{\circ}\text{C}$ ($T_A = 25^{\circ}\text{C}$).

Table 2.

Parameter ¹	Analog Input Full Scale = 1.44 V p-p			Analog Input Full Scale = 1.80 V p-p			Analog Input Full Scale = 2.16 V p-p			Unit
	Min	Typ	Max	Min	Typ	Max	Min	Typ	Max	
ANALOG INPUT FULL SCALE		1.44			1.80			2.16		V p-p
NOISE DENSITY ²		-149.7			-151.5			-153.0		dBFS/Hz
SIGNAL-TO-NOISE RATIO (SNR) ³										
VDR Mode										
$f_{IN} = 10$ MHz		65.4			67.1			68.4		dBFS
$f_{IN} = 155$ MHz		65.3		64.8	67.0			68.3		dBFS
$f_{IN} = 305$ MHz		65.2			66.8			68.0		dBFS
$f_{IN} = 450$ MHz		65.0			66.6			67.8		dBFS
$f_{IN} = 765$ MHz		64.8			66.5			67.5		dBFS
$f_{IN} = 985$ MHz		64.5			66.0			66.9		dBFS
21% Bandwidth (BW) Mode (>105 MHz at 500 MSPS)										
$f_{IN} = 10$ MHz		72.1			73.8			75.1		dBFS
$f_{IN} = 155$ MHz		71.8			73.5			74.8		dBFS
$f_{IN} = 305$ MHz		71.9			73.5			74.7		dBFS
$f_{IN} = 450$ MHz		71.6			73.2			74.4		dBFS
$f_{IN} = 765$ MHz		71.0			72.7			73.7		dBFS
$f_{IN} = 985$ MHz		70.6			72.1			73.0		dBFS
28% BW Mode (>135 MHz at 500 MSPS)										
$f_{IN} = 10$ MHz		69.6			71.3			72.6		dBFS
$f_{IN} = 155$ MHz		69.1			70.8			72.1		dBFS
$f_{IN} = 305$ MHz		69.1			70.7			71.9		dBFS
$f_{IN} = 450$ MHz		69.4			71.0			72.2		dBFS
$f_{IN} = 765$ MHz		68.5			70.2			71.2		dBFS
$f_{IN} = 985$ MHz		68.5			70.0			70.9		dBFS
SIGNAL-TO-NOISE-AND-DISTORTION RATIO (SINAD) ³										
$f_{IN} = 10$ MHz		65.3			67.0			68.2		dBFS
$f_{IN} = 155$ MHz		65.2		64.5	66.8			67.9		dBFS
$f_{IN} = 305$ MHz		65.1			66.6			67.6		dBFS
$f_{IN} = 450$ MHz		65.0			66.4			67.3		dBFS
$f_{IN} = 765$ MHz		64.7			66.1			66.9		dBFS
$f_{IN} = 985$ MHz		64.2			65.5			66.2		dBFS
EFFECTIVE NUMBER OF BITS (ENOB) ³										
$f_{IN} = 10$ MHz		10.5			10.8			11.0		Bits
$f_{IN} = 155$ MHz		10.5		10.4	10.8			10.9		Bits
$f_{IN} = 305$ MHz		10.5			10.7			10.9		Bits
$f_{IN} = 450$ MHz		10.5			10.7			10.8		Bits
$f_{IN} = 765$ MHz		10.4			10.6			10.8		Bits
$f_{IN} = 985$ MHz		10.3			10.6			10.7		Bits

Parameter ¹	Analog Input Full Scale = 1.44 V p-p			Analog Input Full Scale = 1.80 V p-p			Analog Input Full Scale = 2.16 V p-p			Unit
	Min	Typ	Max	Min	Typ	Max	Min	Typ	Max	
SPURIOUS-FREE DYNAMIC RANGE (SFDR) ³										
$f_{IN} = 10$ MHz		89			90			80		dBFS
$f_{IN} = 155$ MHz		89		75	85			77		dBFS
$f_{IN} = 305$ MHz		82			82			78		dBFS
$f_{IN} = 450$ MHz		82			83			77		dBFS
$f_{IN} = 765$ MHz		77			75			72		dBFS
$f_{IN} = 985$ MHz		82			79			76		dBFS
SPURIOUS-FREE DYNAMIC RANGE (SFDR) AT -3 dBFS ³										
$f_{IN} = 10$ MHz		94			94			86		dBFS
$f_{IN} = 155$ MHz		94			90			82		dBFS
$f_{IN} = 305$ MHz		89			90			83		dBFS
$f_{IN} = 450$ MHz		87			86			84		dBFS
$f_{IN} = 765$ MHz		82			80			77		dBFS
$f_{IN} = 985$ MHz		85			82			79		dBFS
WORST HARMONIC, SECOND OR THIRD ³										
$f_{IN} = 10$ MHz		-89			-90			-80		dBFS
$f_{IN} = 155$ MHz		-89			-85	-75		-77		dBFS
$f_{IN} = 305$ MHz		-82			-82			-78		dBFS
$f_{IN} = 450$ MHz		-82			-83			-77		dBFS
$f_{IN} = 765$ MHz		-77			-75			-72		dBFS
$f_{IN} = 985$ MHz		-82			-79			-76		dBFS
WORST HARMONIC, SECOND OR THIRD AT -3 dBFS ³										
$f_{IN} = 10$ MHz		-94			-94			-86		dBFS
$f_{IN} = 155$ MHz		-94			-90			-82		dBFS
$f_{IN} = 305$ MHz		-89			-90			-83		dBFS
$f_{IN} = 450$ MHz		-87			-86			-84		dBFS
$f_{IN} = 765$ MHz		-82			-80			-77		dBFS
$f_{IN} = 985$ MHz		-85			-82			-79		dBFS
WORST OTHER, EXCLUDING SECOND OR THIRD HARMONIC ³										
$f_{IN} = 10$ MHz		-96			-98			-99		dBFS
$f_{IN} = 155$ MHz		-97			-97	-86		-97		dBFS
$f_{IN} = 305$ MHz		-97			-98			-97		dBFS
$f_{IN} = 450$ MHz		-95			-96			-96		dBFS
$f_{IN} = 765$ MHz		-92			-91			-88		dBFS
$f_{IN} = 985$ MHz		-90			-89			-86		dBFS
TWO TONE INTERMODULATION DISTORTION (IMD), AIN1 AND AIN2 = -7 dBFS										
$f_{IN1} = 154$ MHz, $f_{IN2} = 157$ MHz		-93			-90			-84		dBFS
$f_{IN1} = 302$ MHz, $f_{IN2} = 305$ MHz		-90			-90			-84		dBFS
CROSSTALK ⁴		82			82			82		dB
FULL POWER BANDWIDTH ⁵		1.4			1.4			1.4		GHz

¹ See the [AN-835 Application Note, Understanding High Speed ADC Testing and Evaluation](#), for definitions and for details on how these tests were completed.

² Noise density is measured with no analog input signal.

³ See Table 9 for recommended settings for full-scale voltage and buffer current setting.

⁴ Crosstalk is measured at 155 MHz with a -1.0 dBFS analog input on one channel and no input on the adjacent channel.

⁵ Measured with circuit shown in Figure 58.

DIGITAL SPECIFICATIONS

AVDD1 = 0.975 V, AVDD1_SR = 0.975 V, AVDD2 = 1.8 V, AVDD3 = 2.5 V, DVDD = 0.975 V, DRVDD1 = 0.975 V, DRVDD2 = 1.8 V, SPIVDD = 1.8 V, specified maximum sampling rate, clock divider = 4, 1.8 V p-p full-scale differential input, 0.5 V internal reference, $A_{IN} = -1.0$ dBFS, default SPI settings, unless otherwise noted. Minimum and maximum specifications are guaranteed for the full operating junction temperature (T_j) range of -40°C to $+105^{\circ}\text{C}$. Typical specifications represent performance at $T_j = 50^{\circ}\text{C}$ ($T_A = 25^{\circ}\text{C}$).

Table 3.

Parameter	Min	Typ	Max	Unit
CLOCK INPUTS (CLK+, CLK-)				
Logic Compliance		LVDS/LVPECL		
Differential Input Voltage	400	800	1600	mV p-p
Input Common-Mode Voltage		0.69		V
Input Resistance (Differential)		32		k Ω
Input Capacitance			0.9	pF
SYSREF INPUTS (SYSREF+, SYSREF-)¹				
Logic Compliance		LVDS/LVPECL		
Differential Input Voltage	400	800	1800	mV p-p
Input Common-Mode Voltage	0.6	0.69	2.2	V
Input Resistance (Differential)	18	22		k Ω
Input Capacitance (Single-Ended per Pin)		0.7		pF
LOGIC INPUTS (PDWN/STBY)				
Logic Compliance		CMOS		
Logic 1 Voltage	$0.65 \times \text{SPIVDD}$			V
Logic 0 Voltage	0		$0.35 \times \text{SPIVDD}$	V
Input Resistance		10		M Ω
LOGIC INPUTS (SDIO, SCLK, CSB)				
Logic Compliance		CMOS		
Logic 1 Voltage	$0.65 \times \text{SPIVDD}$			V
Logic 0 Voltage	0		$0.35 \times \text{SPIVDD}$	V
Input Resistance		56		k Ω
LOGIC OUTPUT (SDIO)				
Logic Compliance		CMOS		
Logic 1 Voltage ($I_{OH} = 800 \mu\text{A}$)	$\text{SPIVDD} - 0.45 \text{ V}$			V
Logic 0 Voltage ($I_{OL} = 50 \mu\text{A}$)	0		0.45	V
SYNCIN INPUT (SYNCINB+AB, SYNCINB-AB, SYNCINB+CD, SYNCINB-CD)				
Logic Compliance		LVDS/LVPECL/CMOS		
Differential Input Voltage	400	800	1800	mV p-p
Input Common-Mode Voltage	0.6	0.69	2.2	V
Input Resistance (Differential)	18	22		k Ω
Input Capacitance (Single-Ended per Pin)		0.7		pF
LOGIC OUTPUTS (FD_A, FD_B)				
Logic Compliance		CMOS		
Logic 1 Voltage	$0.8 \times \text{SPIVDD}$			V
Logic 0 Voltage	0		0.5	V
Input Resistance		56		k Ω
DIGITAL OUTPUTS (SERDOUTx\pm, x = AB0, AB1, CD0, and CD1)				
Logic Compliance		CML		
Differential Output Voltage		455.8		mV p-p
Short-Circuit Current ($I_{D \text{ SHORT}}$)		15		mA
Differential Termination Impedance		100		Ω

¹ DC-coupled input only.

SWITCHING SPECIFICATIONS

AVDD1 = 0.975 V, AVDD1_SR = 0.975 V, AVDD2 = 1.8 V, AVDD3 = 2.5 V, DVDD = 0.975 V, DRVDD1 = 0.975 V, DRVDD2 = 1.8 V, SPIVDD = 1.8 V, specified maximum sampling rate, clock divider = 4, 1.8 V p-p full-scale differential input, 0.5 V internal reference, A_{IN} = -1.0 dBFS, default SPI settings, unless otherwise noted. Minimum and maximum specifications are guaranteed for the full operating junction temperature (T_j) range of -40°C to +105°C. Typical specifications represent performance at T_j = 50°C (T_A = 25°C).

Table 4.

Parameter	Min	Typ	Max	Unit
CLOCK				
Clock Rate at CLK+/CLK- Pins	0.3		2.4	GHz
Maximum Sample Rate ¹	500			MSPS
Minimum Sample Rate ²	240			MSPS
Clock Pulse Width High	125			ps
Clock Pulse Width Low	125			ps
OUTPUT PARAMETERS				
Unit Interval (UI) ³	66.67	100		ps
Rise Time (t_r) (20% to 80% into 100 Ω Load)		31.25		ps
Fall Time (t_f) (20% to 80% into 100 Ω Load)		31.37		ps
Phase-Locked Loop (PLL) Lock Time		5		ms
Data Rate per Channel (NRZ) ⁴	1.6875	10	15	Gbps
LATENCY⁵				
Pipeline Latency		54		Sample clock cycles
Fast Detect Latency			30	Sample clock cycles
APERTURE				
Aperture Delay (t_A)		160		ps
Aperture Uncertainty (Jitter, t_j)		44		fs rms
Out-of-Range Recovery Time		1		Sample clock cycles

¹ The maximum sample rate is the clock rate after the divider.

² The minimum sample rate operates at 240 MSPS with L = 2 or L = 1. Refer to SPI Register 0x011A to reduce the threshold of the clock detect circuit.

³ Baud rate = 1/UI. A subset of this range can be supported.

⁴ Default L = 2. This number can be changed based on the sample rate and decimation ratio.

⁵ No DDCs used. L = 2, M = 2, F = 2 for each link.

TIMING SPECIFICATIONS**Table 5.**

Parameter	Test Conditions/Comments	Min	Typ	Max	Unit
CLK+ to SYSREF+ TIMING REQUIREMENTS					
t_{SU_SR}	See Figure 3 Device clock to SYSREF+ setup time		-44.8		ps
t_{H_SR}	Device clock to SYSREF+ hold time		64.4		ps
SPI TIMING REQUIREMENTS					
t_{DS}	See Figure 4 Setup time between the data and the rising edge of SCLK	4			ns
t_{DH}	Hold time between the data and the rising edge of SCLK	2			ns
t_{CLK}	Period of the SCLK	40			ns
t_S	Setup time between CSB and SCLK	2			ns
t_H	Hold time between CSB and SCLK	2			ns
t_{HIGH}	Minimum period that SCLK must be in a logic high state	10			ns
t_{LOW}	Minimum period that SCLK must be in a logic low state	10			ns
t_{ACCESS}	Maximum time delay between falling edge of SCLK and output data valid for a read operation		6	10	ns
t_{DIS_SDIO}	Time required for the SDIO pin to switch from an output to an input relative to the CSB rising edge (not shown in Figure 4)	10			ns

Timing Diagrams

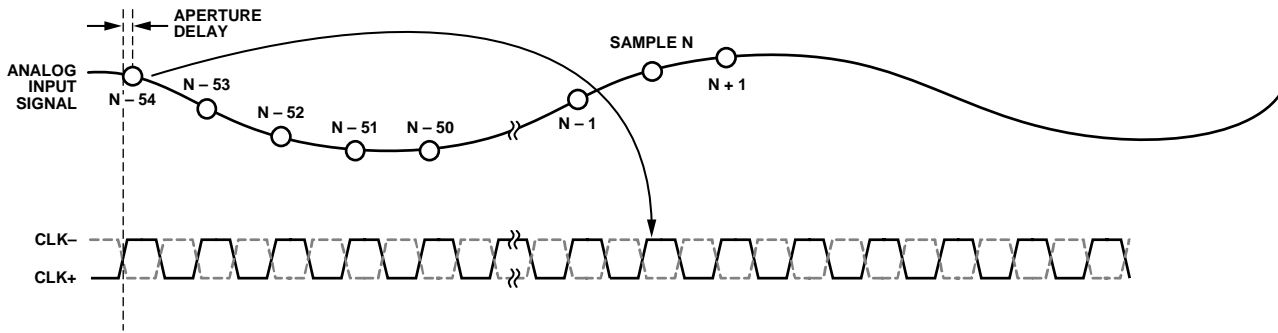

Figure 2. Data Output Timing (NSR Mode, 21%, L, M, F = 222)

14994-002

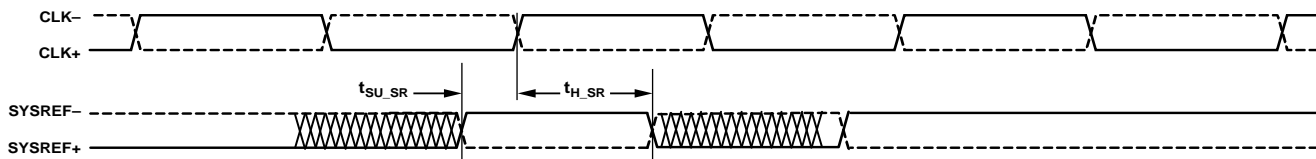

Figure 3. SYSREF± Setup and Hold Timing

14994-003

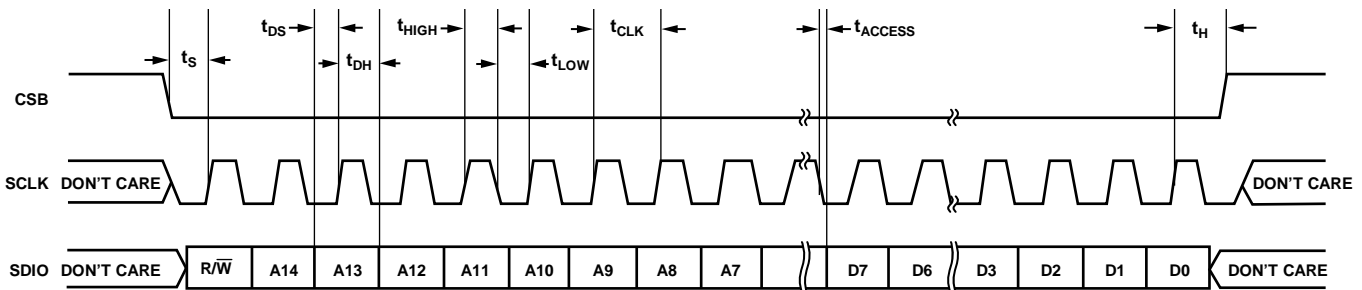

Figure 4. Serial Port Interface Timing Diagram

14994-004

ABSOLUTE MAXIMUM RATINGS

Table 6.

Parameter	Rating
Electrical	
AVDD1 to AGND	1.05 V
AVDD1_SR to AGND	1.05 V
AVDD2 to AGND	2.00 V
AVDD3 to AGND	2.70 V
DVDD to DGND	1.05 V
DRVDD1 to DRGND	1.05 V
DRVDD2 to DRGND	2.00 V
SPIVDD to AGND	2.00 V
VIN±x to AGND	−0.3 V to AVDD3 + 0.3 V
CLK± to AGND	−0.3 V to AVDD1 + 0.3 V
SCLK, SDIO, CSB to DGND	−0.3 V to SPIVDD + 0.3 V
PDWN/STBY to DGND	−0.3 V to SPIVDD + 0.3 V
SYSREF± to AGND_SR	0 V to 2.5 V
SYNCIN±AB/SYNCIN±CD to DRGND	0 V to 2.5 V
Environmental	
Operating Junction Temperature Range	−40°C to +105°C
Maximum Junction Temperature	125°C
Storage Temperature Range (Ambient)	−65°C to +150°C

Stresses at or above those listed under Absolute Maximum Ratings may cause permanent damage to the product. This is a stress rating only; functional operation of the product at these or any other conditions above those indicated in the operational section of this specification is not implied. Operation beyond the maximum operating conditions for extended periods may affect product reliability.

THERMAL CHARACTERISTICS

Thermal performance is directly linked to printed circuit board (PCB) design and operating environment. Careful attention to PCB thermal design is required.

Table 7. Thermal Resistance

PCB Type	Airflow Velocity (m/sec)	θ_{JA}	θ_{JCB}	Unit
JEDEC 2s2p Board	0.0	21.58 ^{1,2}	1.95 ^{1,3}	°C/W
	1.0	17.94 ^{1,2}	N/A ⁴	°C/W
	2.5	16.58 ^{1,2}	N/A ⁴	°C/W
10-Layer Board	0.0	9.74	1.00	°C/W

¹ Per JEDEC 51-7, plus JEDEC 51-5 2s2p test board.

² Per JEDEC JESD51-2 (still air) or JEDEC JESD51-6 (moving air).

³ Per MIL-STD 883, Method 1012.1.

⁴ N/A means not applicable.

ESD CAUTION



ESD (electrostatic discharge) sensitive device. Charged devices and circuit boards can discharge without detection. Although this product features patented or proprietary protection circuitry, damage may occur on devices subjected to high energy ESD. Therefore, proper ESD precautions should be taken to avoid performance degradation or loss of functionality.

PIN CONFIGURATION AND FUNCTION DESCRIPTIONS

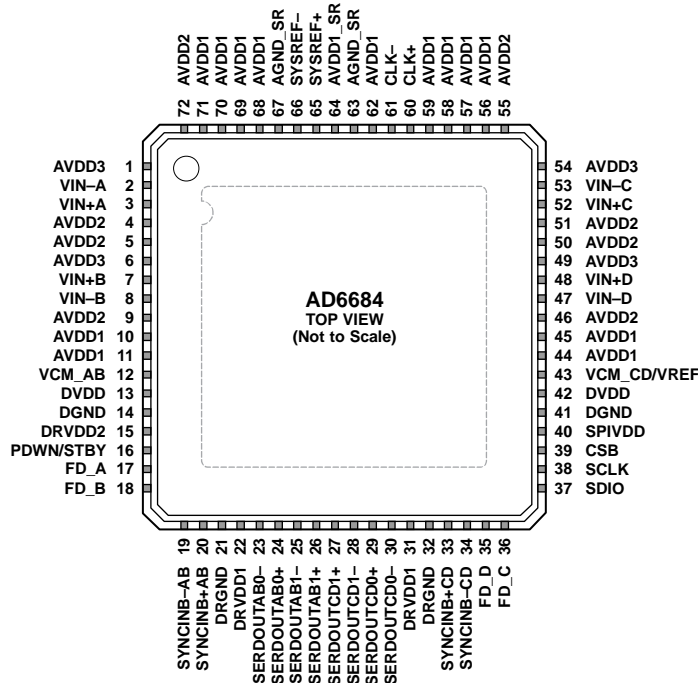

NOTES

1. EXPOSED PAD. ANALOG GROUND. THE EXPOSED THERMAL PAD ON THE BOTTOM OF THE PACKAGE PROVIDES THE GROUND REFERENCE FOR AVDDx, SPIVDD, DVDD, DRVDD1, AND DRVDD2. THIS EXPOSED PAD MUST BE CONNECTED TO GROUND FOR PROPER OPERATION.

14984-005

Figure 5. Pin Configuration (Top View)

Table 8. Pin Function Descriptions

Pin No.	Mnemonic	Type	Description
0	AGND/EPAD	Ground	Exposed Pad. Analog Ground. The exposed thermal pad on the bottom of the package provides the ground reference for AVDDx, SPIVDD, DVDD, DRVDD1, and DRVDD2. This exposed pad must be connected to ground for proper operation.
1, 6, 49, 54	AVDD3	Supply	Analog Power Supply (2.5 V Nominal).
2, 3	VIN–A, VIN+A	Input	ADC A Analog Input Complement/True.
4, 5, 9, 46, 50, 51, 55, 72	AVDD2	Supply	Analog Power Supply (1.8 V Nominal).
7, 8	VIN+B, VIN–B	Input	ADC B Analog Input True/Complement.
10, 11, 44, 45, 56, 57, 58, 59, 62, 68, 69, 70, 71	AVDD1	Supply	Analog Power Supply (0.975 V Nominal).
12	VCM_AB	Output	Common-Mode Level Bias Output for Analog Input Channel A and Channel B
13, 42	DVDD	Supply	Digital Power Supply (0.975 V Nominal).
14, 41	DGND	Ground	Ground Reference for DVDD and SPIVDD.
15	DRVDD2	Supply	Digital Power Supply for JESD204B PLL (1.8 V Nominal).
16	PDWN/STBY	Input	Power-Down Input (Active High). The operation of this pin depends on the SPI mode and can be configured as power-down or standby. Requires external 10 kΩ pull-down resistor.
17, 18, 36, 35	FD_A, FD_B, FD_C, FD_D	Output	Fast Detect Outputs for Channel A, Channel B, Channel C, and Channel D.
19	SYNCINB–AB	Input	Active Low JESD204B LVDS Sync Input Complement for Channel A and Channel B.
20	SYNCINB+AB	Input	Active Low JESD204B LVDS/CMOS Sync Input True for Channel A and Channel B.
21, 32	DRGND	Ground	Ground Reference for DRVDD1 and DRVDD2.
22, 31	DRVDD1	Supply	Digital Power Supply for SERDOUT Pins (0.975 V Nominal).

Pin No.	Mnemonic	Type	Description
23, 24	SERDOUTAB0-, SERDOUTAB0+	Output	Lane 0 Output Data Complement/True for Channel A and Channel B.
25, 26	SERDOUTAB1-, SERDOUTAB1+	Output	Lane 1 Output Data Complement/True for Channel A and Channel B.
27, 28	SERDOUTCD1+, SERDOUTCD1-	Output	Lane 1 Output Data True/Complement for Channel C and Channel D.
29, 30	SERDOUTCD0+, SERDOUTCD0-	Output	Lane 0 Output Data True/Complement for Channel C and Channel D.
33	SYNCINB+CD	Input	Active Low JESD204B LVDS/CMOS Sync Input True for Channel C and Channel D.
34	SYNCINB-CD	Input	Active Low JESD204B LVDS Sync Input Complement for Channel C and Channel D.
37	SDIO	Input/output	SPI Serial Data Input/Output.
38	SCLK	Input	SPI Serial Clock.
39	CSB	Input	SPI Chip Select (Active Low).
40	SPIVDD	Supply	Digital Power Supply for SPI (1.8 V Nominal).
43	VCM_CD/VREF	Output/input	Common-Mode Level Bias Output for Analog Input Channel C and Channel D/0.5 V Reference Voltage Input. This pin is configurable through the SPI as an output or an input. Use this pin as the common-mode level bias output if using the internal reference. This pin requires a 0.5 V reference voltage input if using an external voltage reference source.
47, 48	VIN-D, VIN+D	Input	ADC D Analog Input Complement/True.
52, 53	VIN+C, VIN-C	Input	ADC C Analog Input True/Complement.
60, 61	CLK+, CLK-	Input	Clock Input True/Complement.
63, 67	AGND_SR	Ground	Ground Reference for SYSREF±.
64	AVDD1_SR	Supply	Analog Power Supply for SYSREF± (0.975 V Nominal).
65, 66	SYSREF+, SYSREF-	Input	Active Low JESD204B LVDS System Reference (SYSREF) Input True/Complement. DC-coupled input only.

TYPICAL PERFORMANCE CHARACTERISTICS

AVDD1 = 0.975 V, AVDD1_SR = 0.975 V, AVDD2 = 1.8 V, AVDD3 = 2.5 V, DVDD = 0.975 V, DRVDD1 = 0.975 V, DRVDD2 = 1.8 V, SPIVDD = 1.8 V, specified maximum sampling rate, clock divider = 4, 1.5 V p-p full-scale differential input, $A_{IN} = -1.0$ dBFS, default SPI settings, VDR mode (input mask not triggered), unless otherwise noted. Minimum and maximum specifications are guaranteed for the full operating junction temperature (T_J) range of -40°C to $+105^{\circ}\text{C}$. Typical specifications represent performance at $T_J = 50^{\circ}\text{C}$ ($T_A = 25^{\circ}\text{C}$).

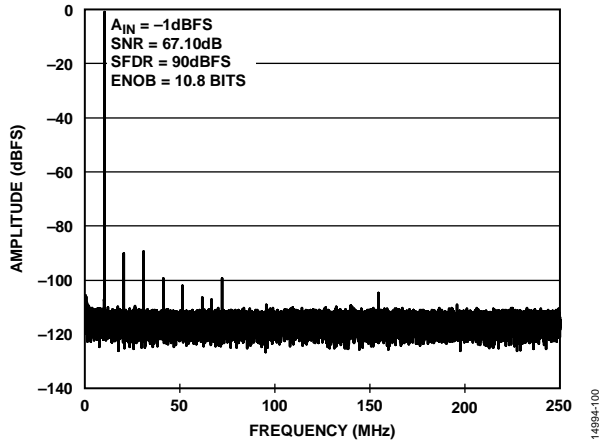

Figure 6. Single-Tone FFT with $f_{IN} = 10.3$ MHz

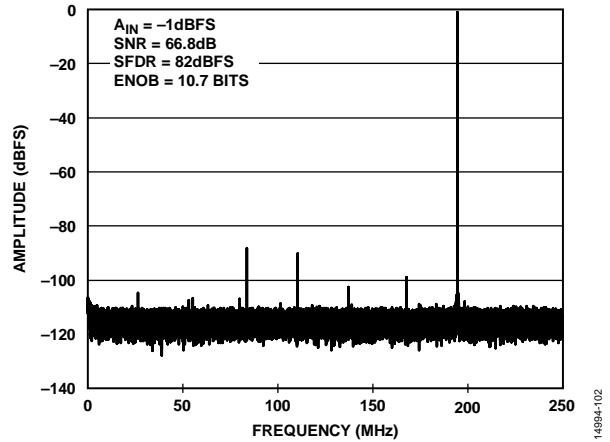

Figure 8. Single-Tone FFT with $f_{IN} = 305$ MHz

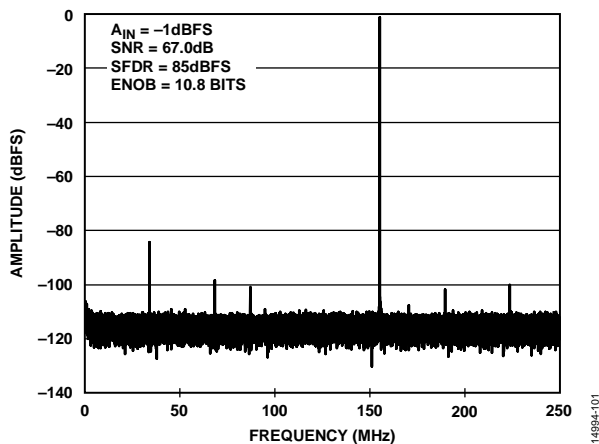

Figure 7. Single-Tone FFT with $f_{IN} = 155$ MHz

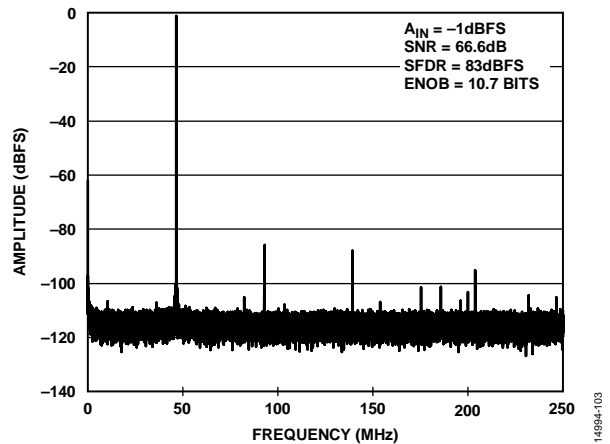

Figure 9. Single-Tone FFT with $f_{IN} = 453$ MHz

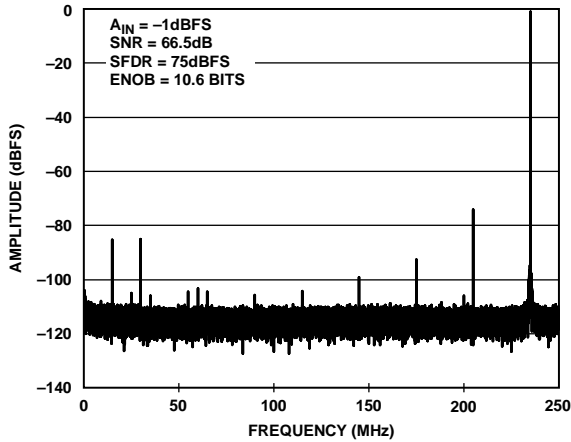

Figure 10. Single-Tone FFT with $f_{IN} = 765$ MHz

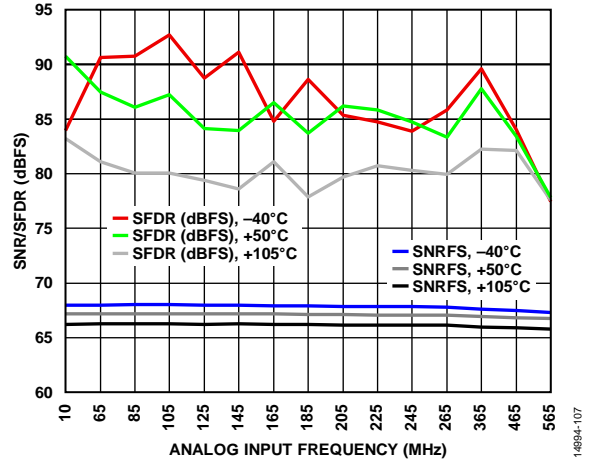

Figure 13. SNR/SFDR vs. Analog Input Frequency (f_{IN})

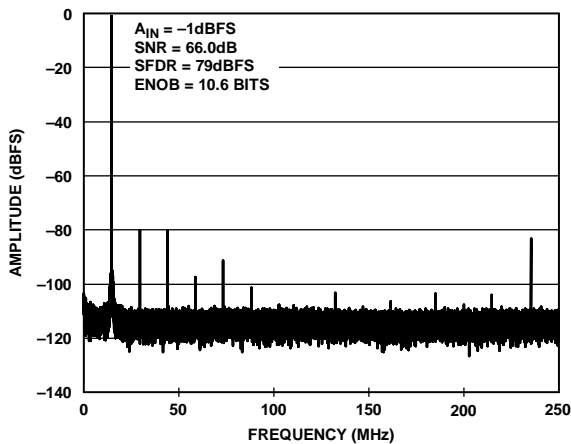

Figure 11. Single-Tone FFT with $f_{IN} = 985$ MHz

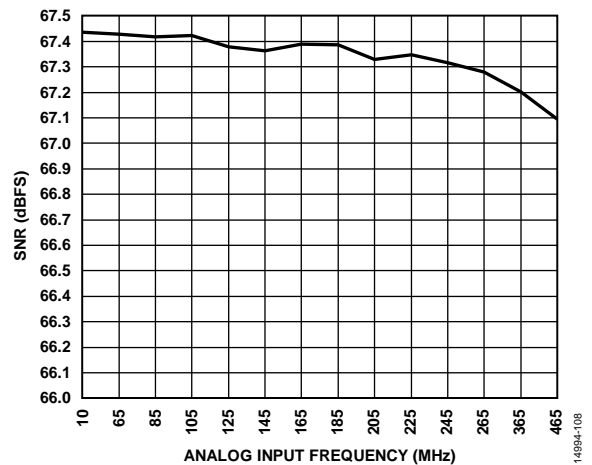

Figure 14. SNR vs. Analog Input Frequency (f_{IN}), First and Second Nyquist Zones; A_{IN} at -3 dBFS

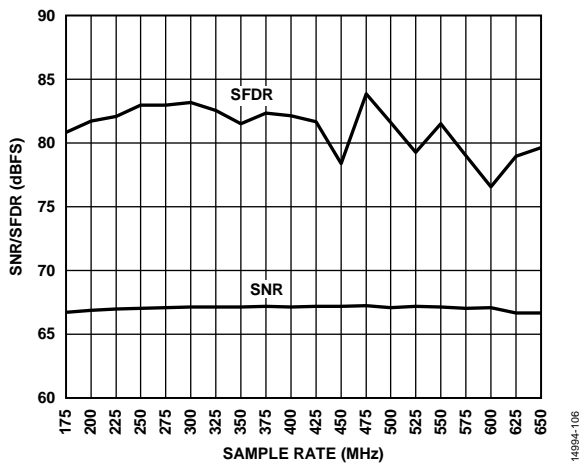

Figure 12. SNR/SFDR vs. Sample Rate (f_s), $f_{IN} = 155$ MHz

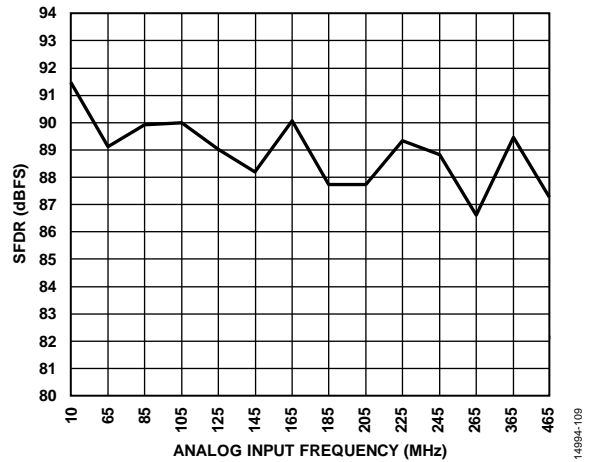

Figure 15. SFDR vs. Analog Input Frequency (f_{IN}), First and Second Nyquist Zones; A_{IN} at -3 dBFS

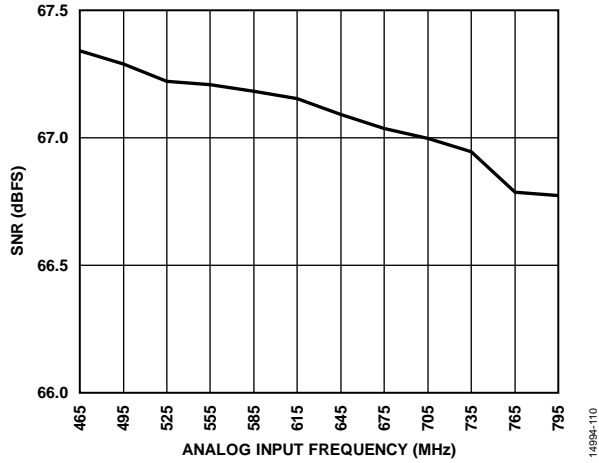

Figure 16. SNR vs. Analog Input Frequency (f_{IN}), Third Nyquist Zone; A_{IN} at -3 dBFS

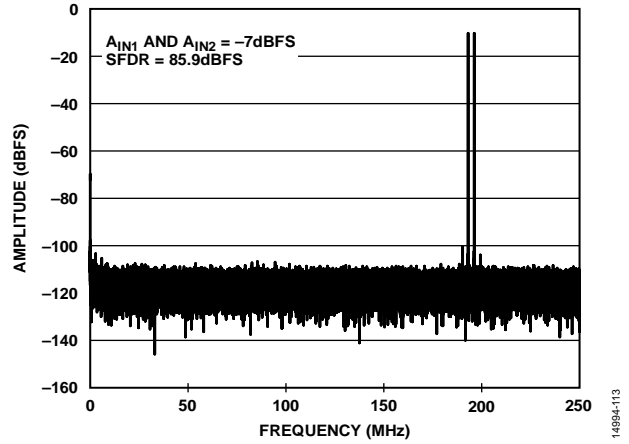

Figure 19. Two Tone FFT; $f_{IN1} = 303.5$ MHz, $f_{IN2} = 306.5$ MHz

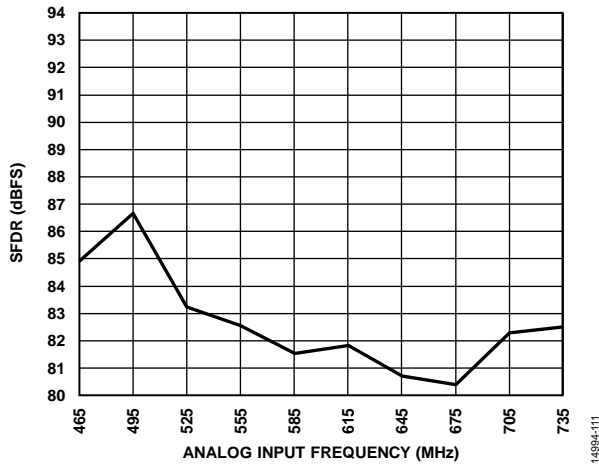

Figure 17. SFDR vs. Analog Input Frequency (f_{IN}), Third Nyquist Zone; A_{IN} at -3 dBFS

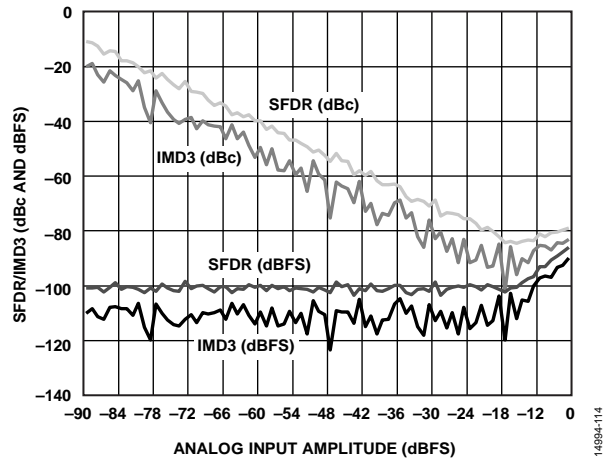

Figure 20. Two Tone SFDR/IMD3 vs. Analog Input Amplitude (A_{IN}) with $f_{IN1} = 303.5$ MHz and $f_{IN2} = 306.5$ MHz

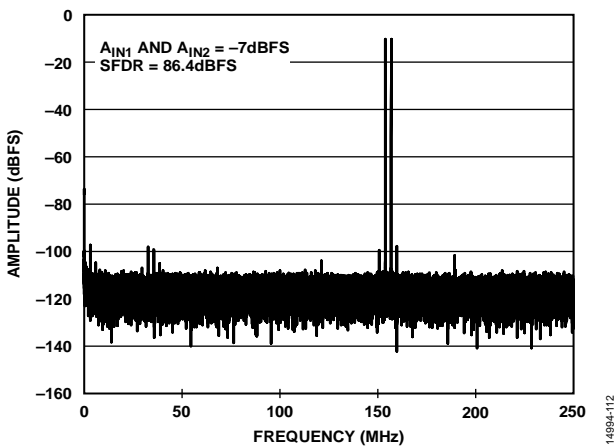

Figure 18. Two Tone FFT; $f_{IN1} = 153.5$ MHz, $f_{IN2} = 156.5$ MHz

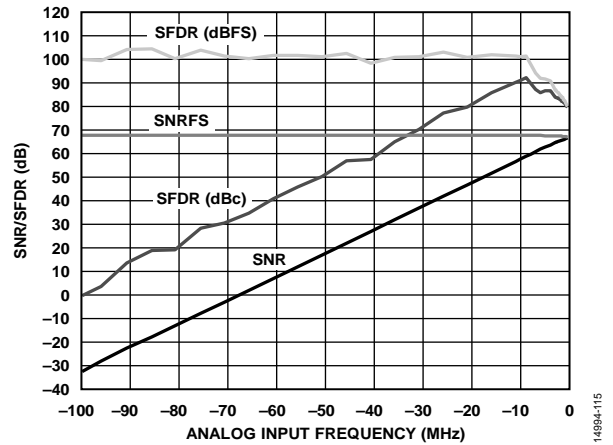

Figure 21. SNR/SFDR vs. Analog Input Frequency, $f_{IN} = 155$ MHz

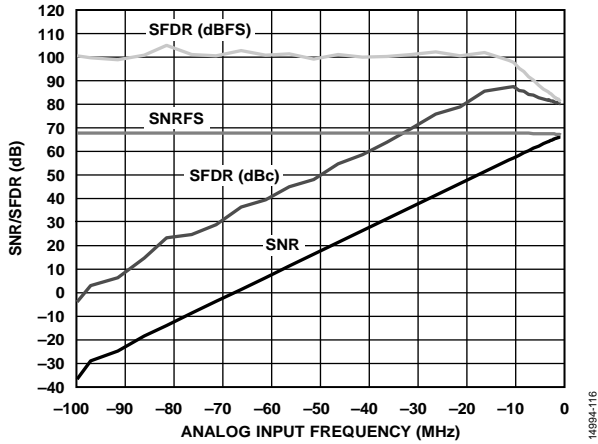

Figure 22. SNR/SFDR vs. Analog Input Frequency, $f_{IN} = 305$ MHz

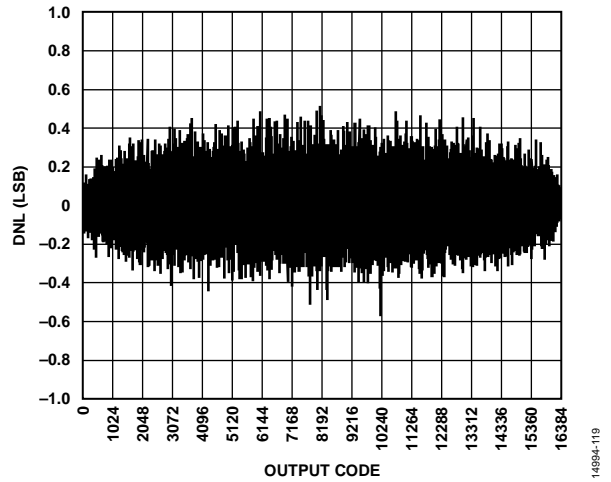

Figure 25. DNL, $f_{IN} = 10.3$ MHz

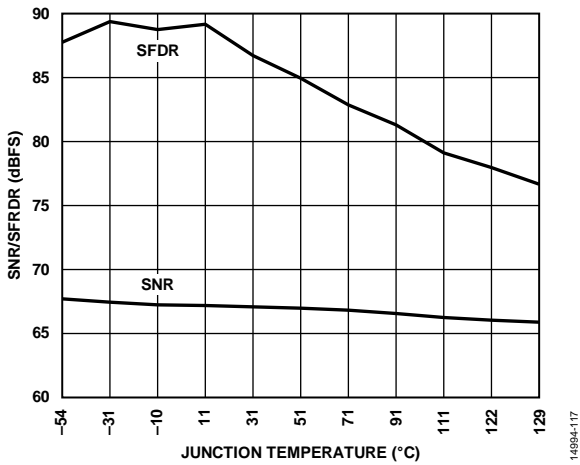

Figure 23. SNR/SFDR vs. Junction Temperature, $f_{IN} = 155$ MHz

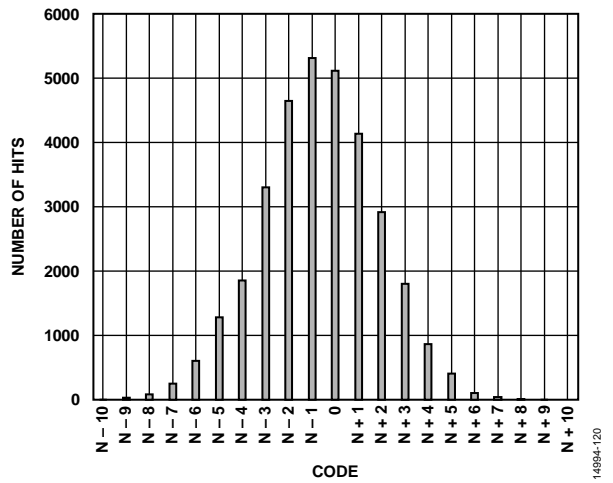

Figure 26. Input-Referred Noise Histogram

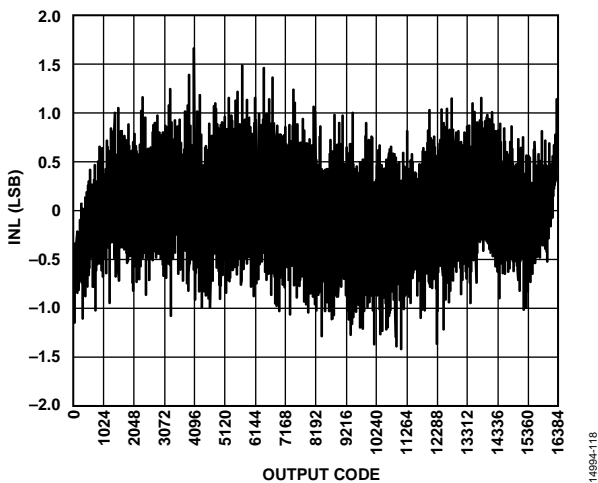

Figure 24. INL, $f_{IN} = 10.3$ MHz

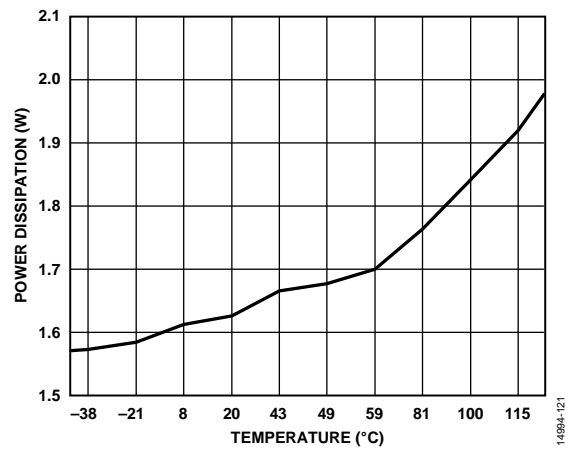

Figure 27. NSR Mode Power Dissipation vs. Junction Temperature

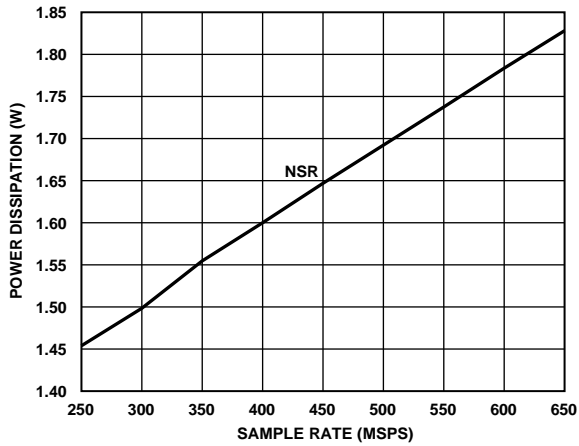

Figure 28. Power Dissipation vs. Sample Rate (f_s)

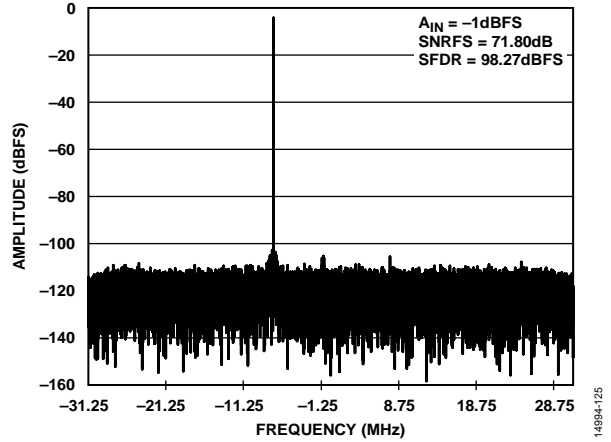

Figure 31. DDC Mode (4 DDCs, Decimate by 8, L, M, and F = 148) with $f_{IN} = 305$ MHz

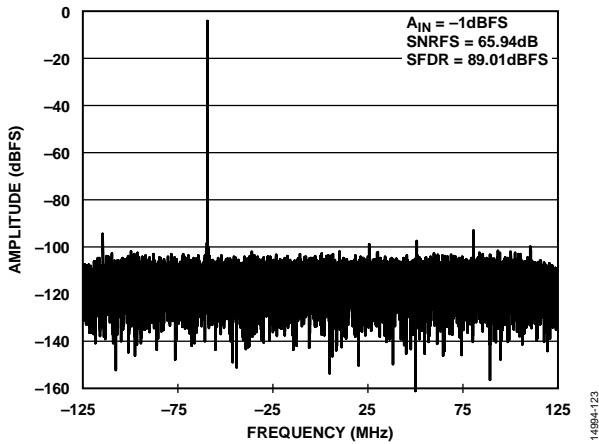

Figure 29. DDC Mode (4 DDCs, DCM2, L, M, and F = 244) with $f_{IN} = 305$ MHz

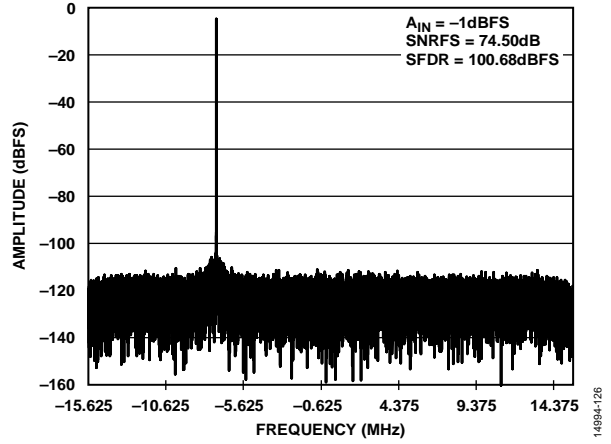

Figure 32. DDC Mode (4 DDCs, Decimate by 16, L, M, and F = 148) with $f_{IN} = 305$ MHz

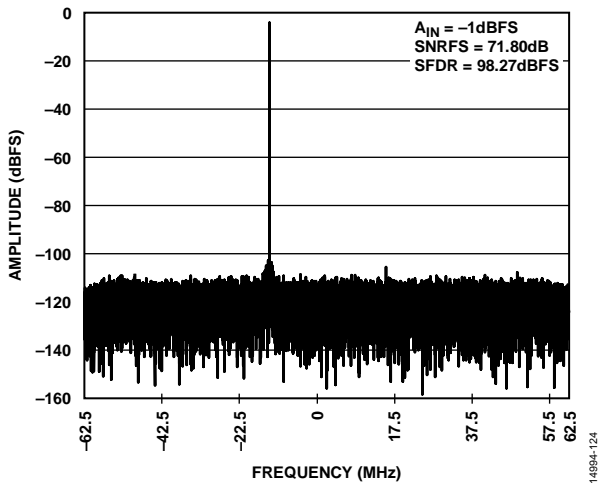

Figure 30. DDC Mode (4 DDCs, Decimate by 4, L, M, and F = 148) with $f_{IN} = 305$ MHz

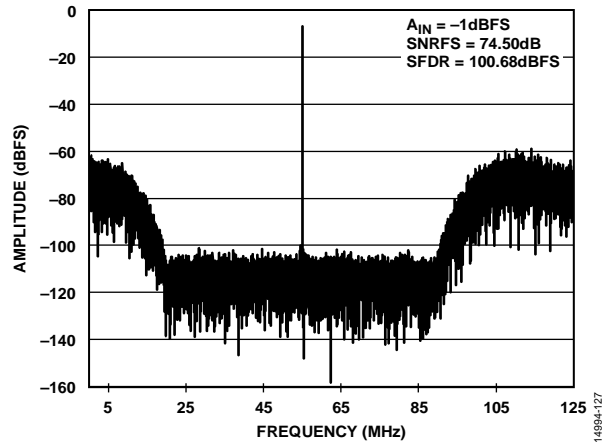

Figure 33. NSR Mode (Decimate by 2, L, M, and F = 124) with $f_{IN} = 305$ MHz

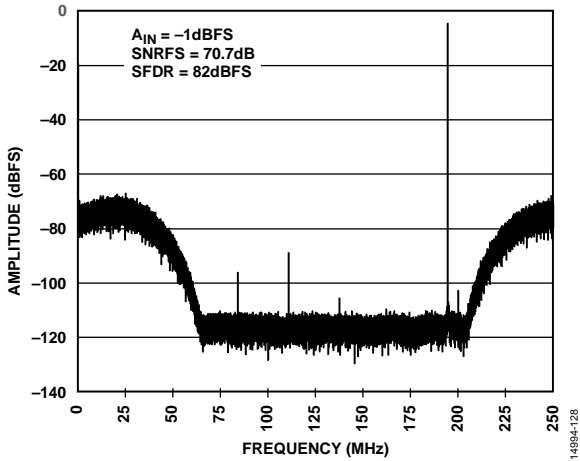

Figure 34. NSR Mode (LMF = 222) with $f_{IN} = 305$ MHz

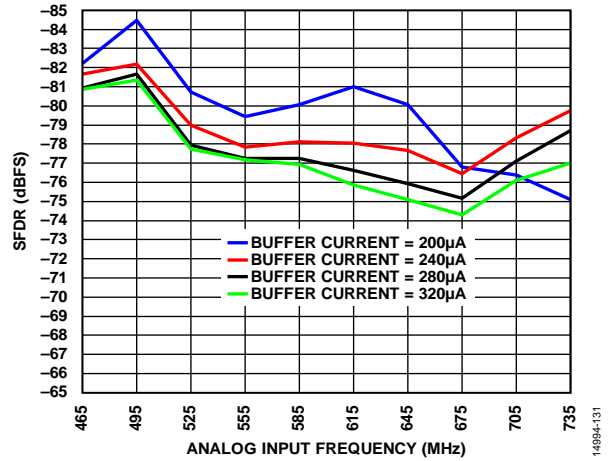

Figure 37. SFDR vs. Analog Input Frequency with Different Buffer Current Settings (Third Nyquist Zone)

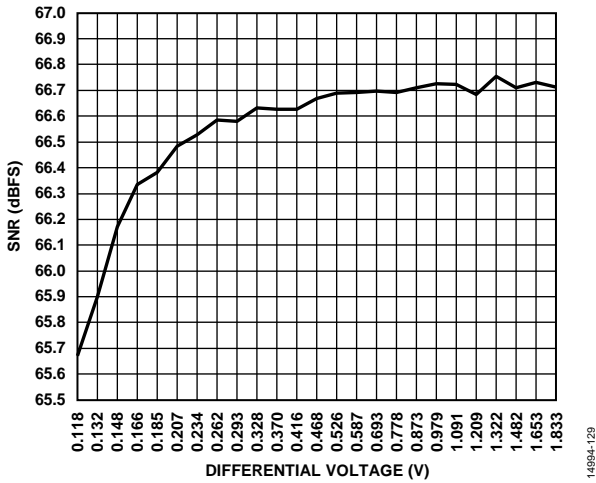

Figure 35. SNR vs. Clock Amplitude (Differential Voltage), $f_{IN} = 155.3$ MHz

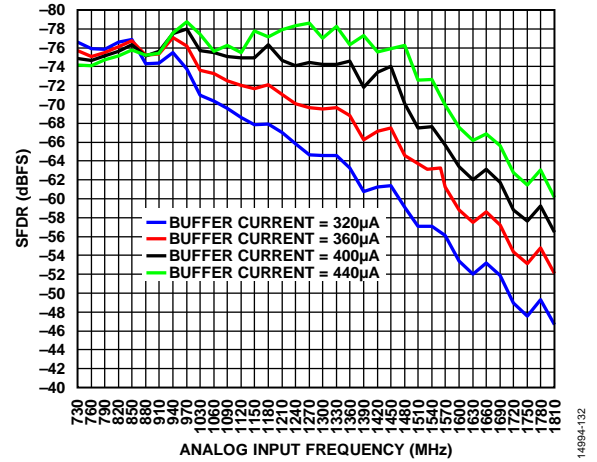

Figure 38. SFDR vs. Analog Input Frequency with Different Buffer Current Settings (Fourth Nyquist Zone)

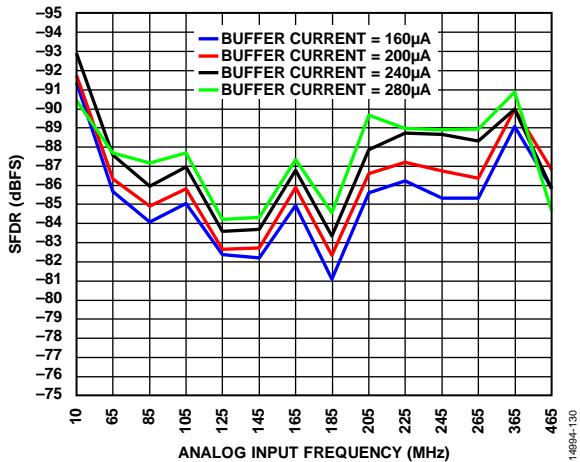

Figure 36. SFDR vs. Analog Input Frequency with Different Buffer Current Settings (First and Second Nyquist Zones)

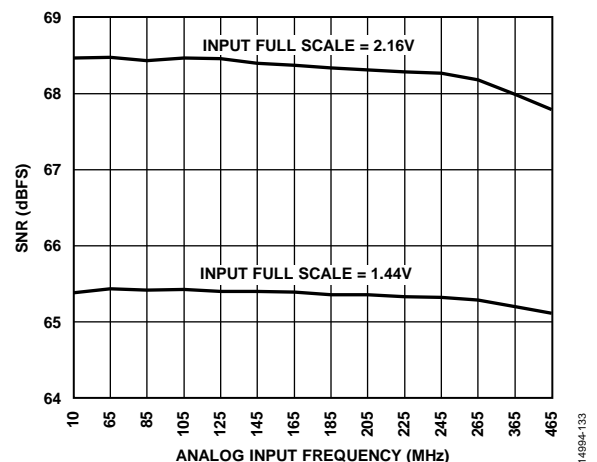

Figure 39. SNR vs. Analog Input Frequency with Different Analog Input Full Scales (First and Second Nyquist Zones)

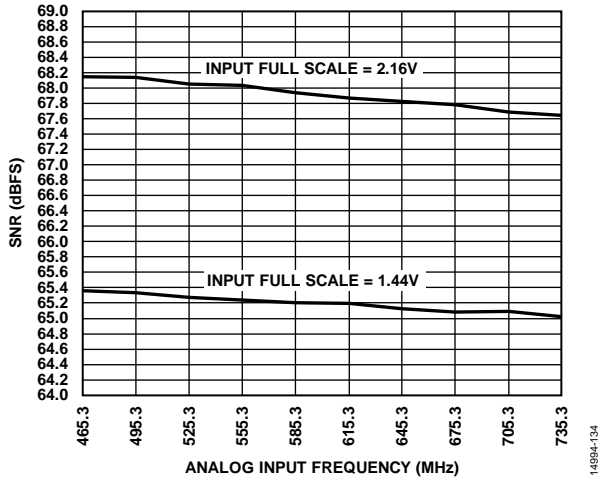

Figure 40. SNR vs. Analog Input Frequency with Different Analog Input Full Scales (Third Nyquist Zone)

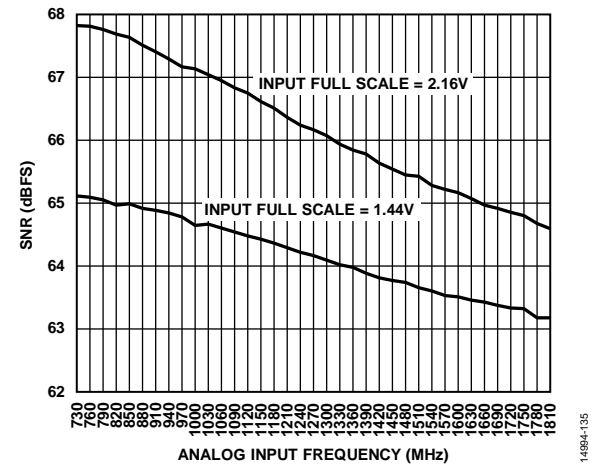

Figure 41. SNR vs. Analog Input Frequency with Different Analog Input Full Scales (Fourth Nyquist Zone)

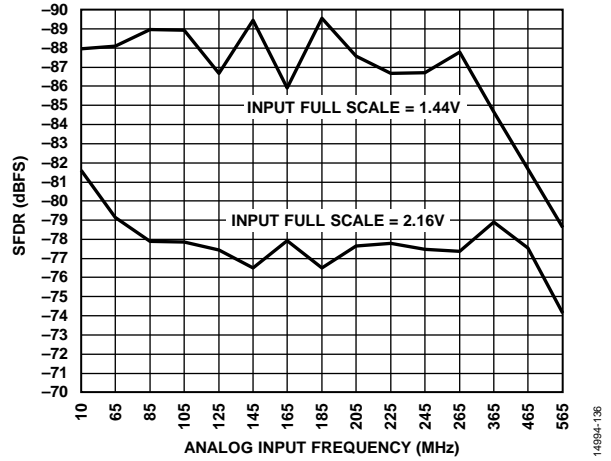

Figure 42. SFDR vs. Analog Input Frequency with Different Analog Input Full Scales (First and Second Nyquist Zones)

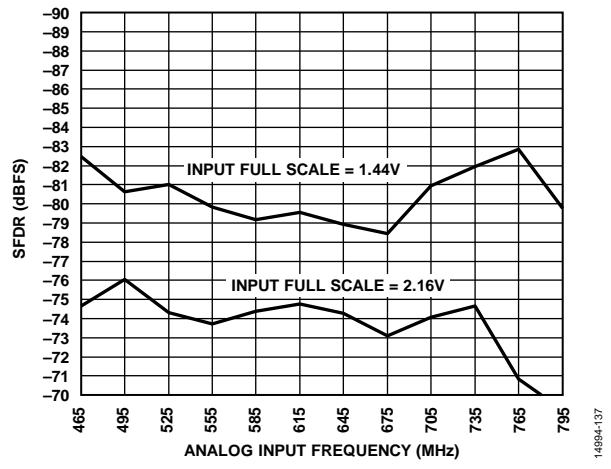

Figure 43. SFDR vs. Analog Input Frequency with Different Analog Input Full Scales (Third Nyquist Zone)

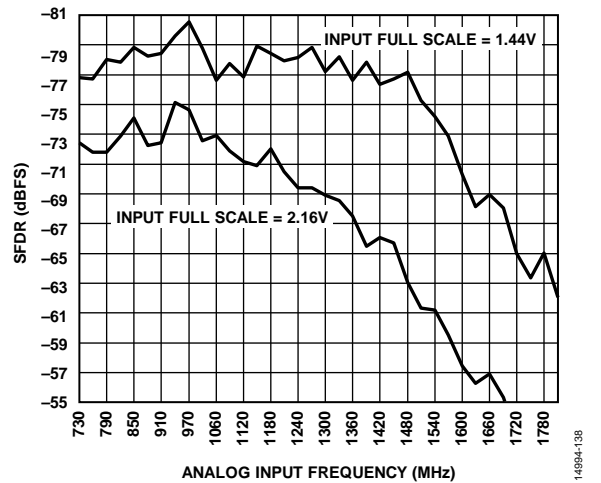

Figure 44. SFDR vs. Analog Input Frequency with Different Analog Input Full Scales (Fourth Nyquist Zone)

EQUIVALENT CIRCUITS

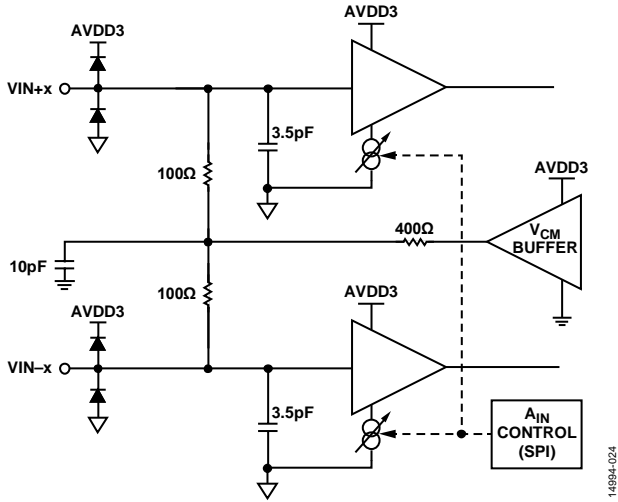

Figure 45. Analog Inputs

14894-024

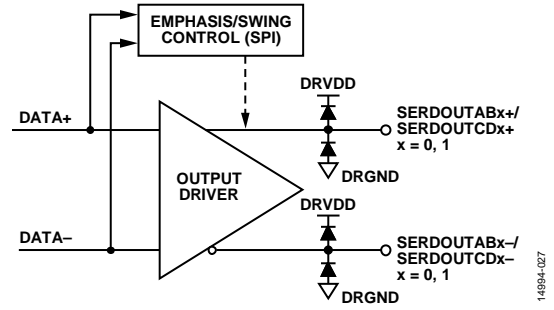

Figure 48. Digital Outputs

14894-027

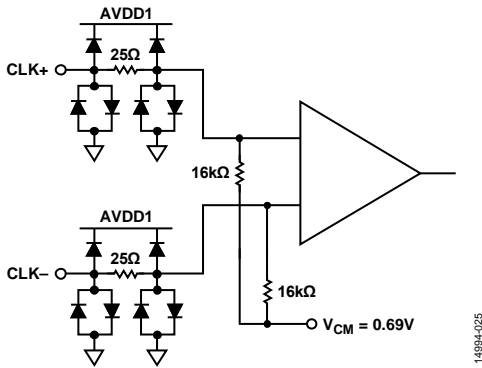

Figure 46. Clock Inputs

14894-025

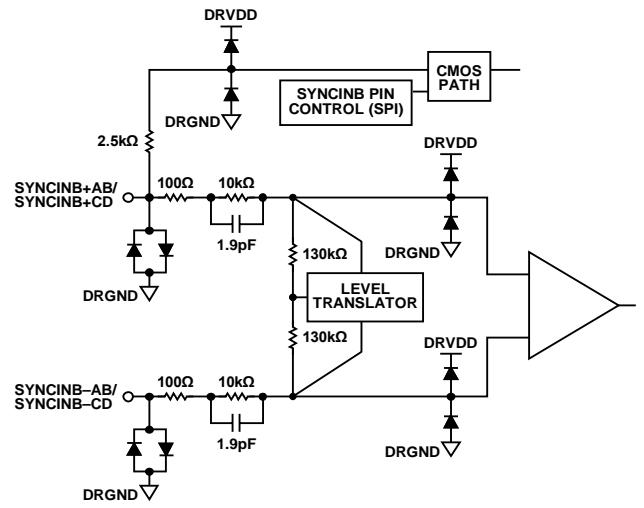

Figure 49. SYNCINB±AB, SYNCINB±CD Inputs

14894-028

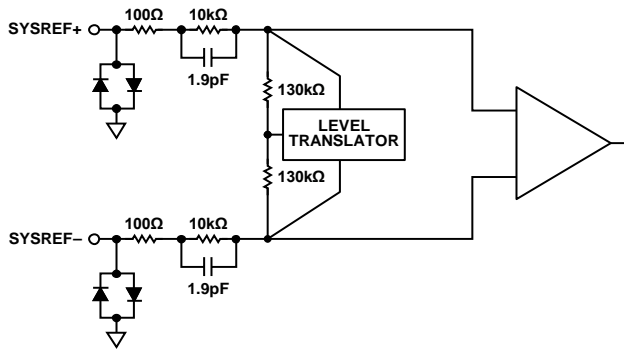

Figure 47. SYSREF± Inputs

14894-026

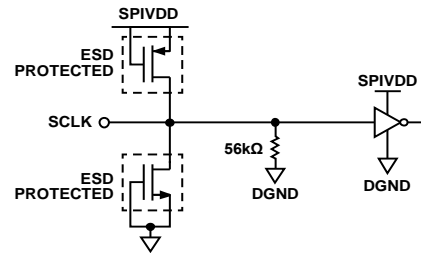

Figure 50. SCLK Input

14894-029

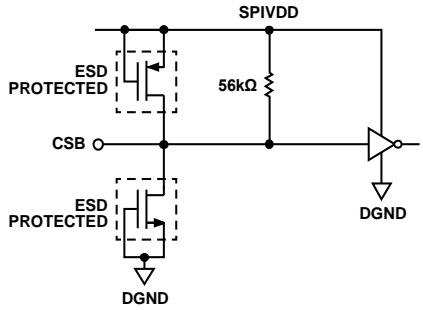

Figure 51. CSB Input

14894-030

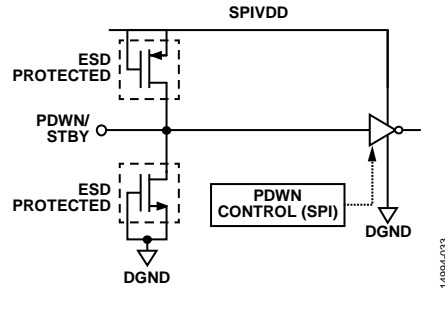

Figure 54. PDWN/STBY Input

14894-033

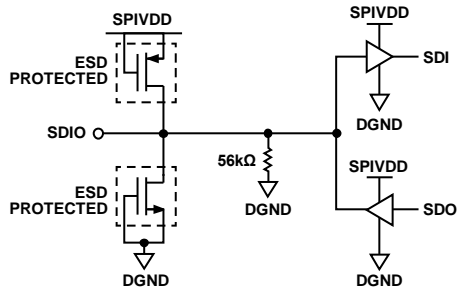

Figure 52. SDIO Input

14894-031

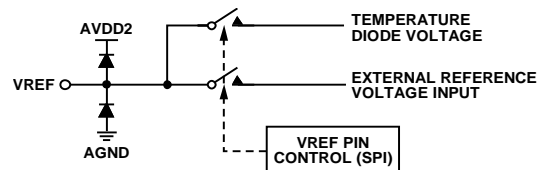

Figure 55. VREF Input/Output

14894-034

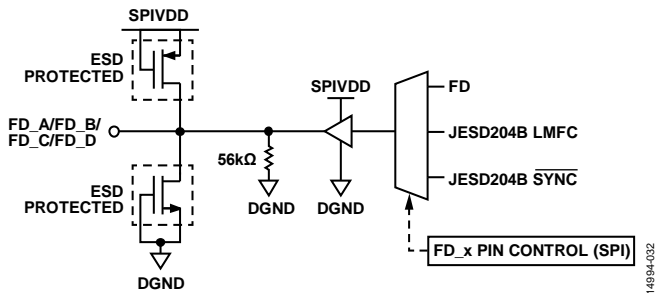

Figure 53. FD_A/FD_B/FD_C/FD_D Outputs

14894-032

THEORY OF OPERATION

ADC ARCHITECTURE

The architecture of the AD6684 consists of an input buffered pipelined ADC. The input buffer is designed to provide a 200 Ω termination impedance to the analog input signal. The equivalent circuit diagram of the analog input termination is shown in Figure 45.

The input buffer provides a linear high input impedance (for ease of drive) and reduces kickback from the ADC. The buffer is optimized for high linearity, low noise, and low power. The quantized outputs from each stage are combined into a final 14-bit result in the digital correction logic. The pipelined architecture permits the first stage to operate with a new input sample while, at the same time, the remaining stages operate with the preceding samples. Sampling occurs on the rising edge of the clock.

ANALOG INPUT CONSIDERATIONS

The analog input to the AD6684 is a differential buffer with an internal common-mode voltage of 1.34 V. The clock signal alternately switches the input circuit between sample mode and hold mode. Either a differential capacitor or two single-ended capacitors can be placed on the inputs to provide a matching passive network. This configuration ultimately creates a low-pass filter at the input, which limits unwanted broadband noise. See Figure 57 and Figure 58 for details on input network recommendations. For more information, see the *Analog Dialogue* article “[Transformer-Coupled Front-End for Wideband A/D Converters](#)” (Volume 39, April 2005). In general, the precise values depend on the application.

For best dynamic performance, the source impedances driving V_{IN+x} and V_{IN-x} must be matched such that common-mode settling errors are symmetrical. These errors are reduced by the common-mode rejection of the ADC. An internal reference buffer creates a differential reference that defines the span of the ADC core.

Maximum SNR performance is achieved by setting the ADC to the largest span in a differential configuration. In the case of the AD6684, the available span is programmable through the SPI port from 1.44 V p-p to 2.16 V p-p differential with 1.80 V p-p differential being the default.

Dither

The AD6684 has internal on-chip dither circuitry that improves the ADC linearity and SFDR, particularly at smaller signal levels. A known but random amount of white noise is injected into the input of the AD6684. This dither improves the small signal linearity within the ADC transfer function and is precisely subtracted out digitally. The dither is turned on by default and does not reduce the ADC input dynamic range. The data sheet specifications and limits are obtained with the dither turned on. The dither can be disabled using SPI writes to Register 0x0922. Disabling the dither can slightly improve the SNR (by about 0.2 dB) at the expense of the small signal SFDR.

Differential Input Configurations

There are several ways to drive the AD6684, either actively or passively. However, optimum performance is achieved by driving the analog input differentially.

For applications where SNR and SFDR are key parameters, differential transformer coupling is the recommended input configuration (see Figure 57 and Figure 58) because the noise performance of most amplifiers is not adequate to achieve the true performance of the AD6684.

For low to midrange frequencies, a double balun or double transformer network (see Figure 57) is recommended for optimum performance of the AD6684. For higher frequencies in the second or third Nyquist zones, it is recommended to remove some of the front-end passive components to ensure wideband operation (see Figure 58).

Input Common Mode

The analog inputs of the AD6684 are internally biased to the common mode as shown in Figure 56.

For dc-coupled applications, the recommended operation procedure is to export the common-mode voltage to the VCM_CD/VREF pin using the SPI writes listed in this section. The common-mode voltage must be set by the exported value to ensure proper ADC operation. Disconnect the internal common-mode buffer from the analog input using Register 0x1908.

When performing SPI writes for dc coupling operation, use the following register settings in order:

1. Set Register 0x1908, Bit 2 to 1; this setting disconnects the internal common-mode buffer from the analog input.
2. Set Register 0x18A6 to 0x00; this setting turns off the voltage reference.
3. Set Register 0x18E6 to 0x00; this setting turns off the temperature diode export.
4. Set Register 0x18E0 to 0x04.
5. Set Register 0x18E1 to 0x1C.
6. Set Register 0x18E2 to 0x14.
7. Set Register 0x18E3, Bit 6 to 0x01; this setting turns on the VCM export.
8. Set Register 0x18E3, Bits[5:0] to the buffer current setting (copy the buffer current setting from Register 0x1A4C and Register 0x1A4D to improve the accuracy of the common-mode export).

Analog Input Controls and SFDR Optimization

The AD6684 offers flexible controls for the analog inputs, such as buffer current and input full-scale adjustment. All of the available controls are shown in Figure 56.

Using Register 0x1A4C and Register 0x1A4D, the buffer currents on each channel can be scaled to optimize the SFDR over various input frequencies and bandwidths of interest. As the input buffer currents are set, the amount of current required by the AVDD3 supply changes. This relationship is shown in Figure 59. For a complete list of buffer current settings, see Table 46.

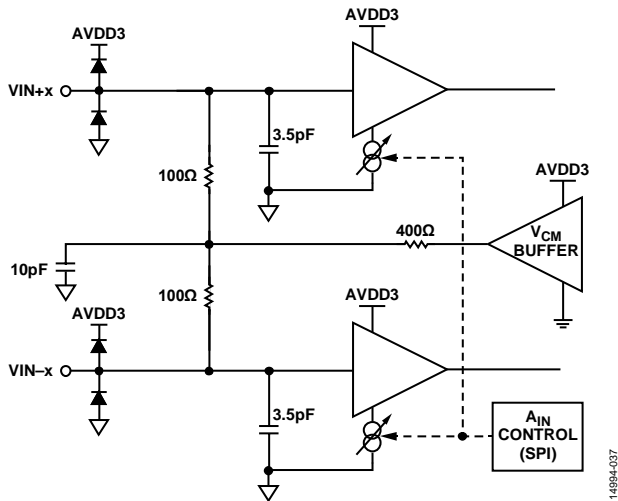

Figure 56. Analog Input Controls

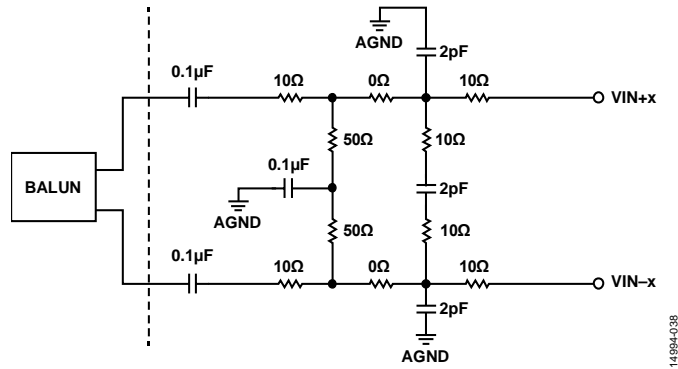

Figure 57. Differential Transformer Coupled Configuration for First and Second Nyquist Frequencies

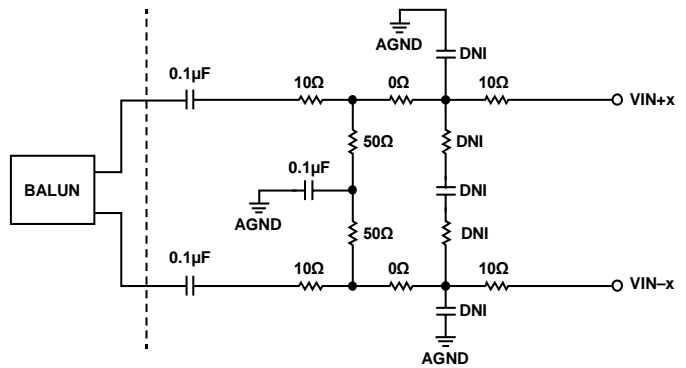

Figure 58. Differential Transformer Coupled Configuration for Third and Fourth Nyquist Zones

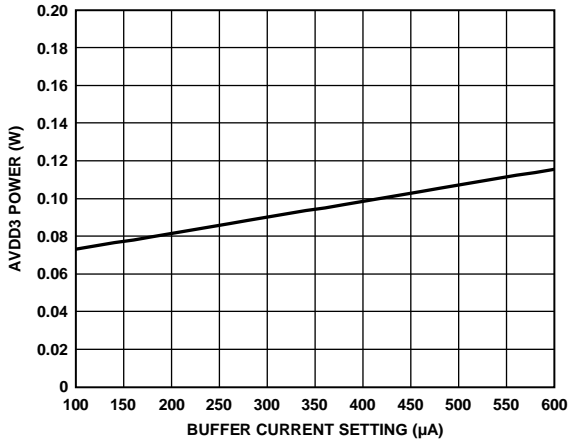

Figure 59. AVDD3 Power vs. Buffer Current Setting

In certain high frequency applications, the SFDR can be improved by reducing the full-scale setting.

Table 9 shows the recommended buffer current settings for the different analog input frequency ranges.

Table 9. SFDR Optimization for Input Frequencies

Nyquist Zone	Input Buffer Current Control Setting, Register 0x1A4C and Register 0x1A4D
First, Second, and Third Nyquist	240 (Register 0x1A4C, Bits[5:0] = Register 0x1A4D, Bits[5:0] = 01100)
Fourth Nyquist	400 (Register 0x1A4C, Bits[5:0] = Register 0x1A4D, Bits[5:0] = 10100)

Absolute Maximum Input Swing

The absolute maximum input swing allowed at the inputs of the AD6684 is 4.3 V p-p differential. Signals operating near or at this level can cause permanent damage to the ADC.

VOLTAGE REFERENCE

A stable and accurate 0.5 V voltage reference is built into the AD6684. This internal 0.5 V reference is used to set the full-scale input range of the ADC. The full-scale input range can be adjusted via the ADC function register (Register 0x1910). For more information on adjusting the input swing, see Table 46. Figure 60 shows the block diagram of the internal 0.5 V reference controls.

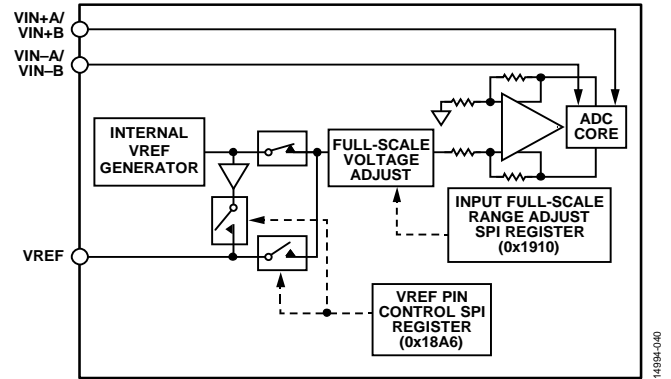

Figure 60. Internal Reference Configuration and Controls

The SPI Register 0x18A6 enables the user to either use this internal 0.5 V reference, or to provide an external 0.5 V reference. When using an external voltage reference, provide a 0.5 V reference. The full-scale adjustment is made using the SPI, irrespective of the reference voltage. For more information on adjusting the full-scale level of the AD6684, refer to the Memory Map section.

The SPI writes required to use the external voltage reference, in order, are as follows:

1. Set Register 0x18E3 to 0x00 to turn off VCM export.
2. Set Register 0x18E6 to 0x00 to turn off temperature diode export.
3. Set Register 0x18A6 to 0x01 to turn on the external voltage reference.

The use of an external reference may be necessary, in some applications, to enhance the gain accuracy of the ADC or to improve thermal drift characteristics.

The external reference has to be a stable 0.5 V reference. The ADR130 is a good option for providing the 0.5 V reference. Figure 61 shows how the ADR130 can be used to provide the external 0.5 V reference to the AD6684. The grayed out areas show unused blocks within the AD6684 while using the ADR130 to provide the external reference.

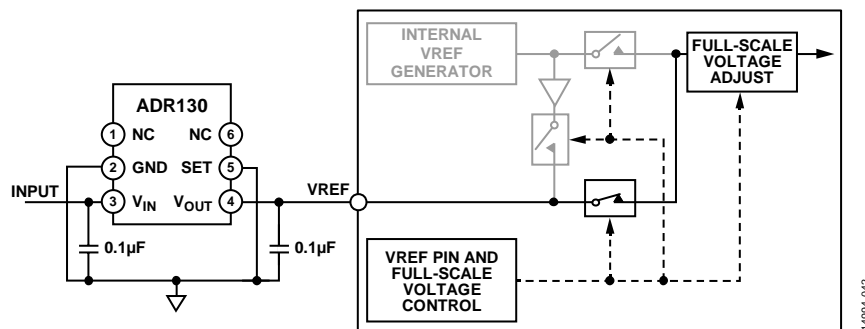

Figure 61. External Reference Using ADR130

CLOCK INPUT CONSIDERATIONS

For optimum performance, drive the AD6684 sample clock inputs (CLK+ and CLK-) with a differential signal. This signal is typically ac-coupled to the CLK+ and CLK- pins via a transformer or clock drivers. These pins are biased internally and require no additional biasing.

Figure 62 shows a preferred method for clocking the AD6684. The low jitter clock source is converted from a single-ended signal to a differential signal using an RF transformer.

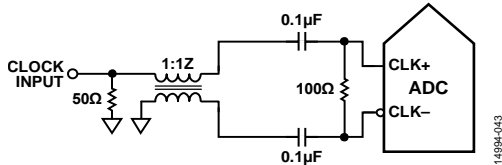

Figure 62. Transformer-Coupled Differential Clock

Another option is to ac couple a differential CML or LVDS signal to the sample clock input pins, as shown in Figure 63 and Figure 64.

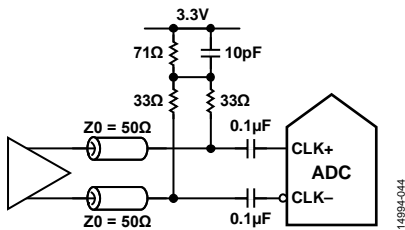
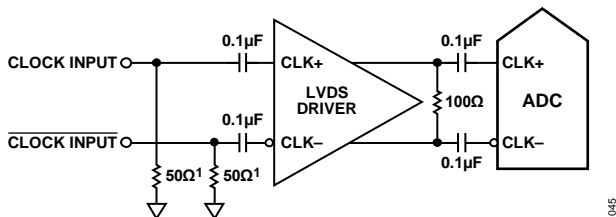

Figure 63. Differential CML Sample Clock



150Ω RESISTORS ARE OPTIONAL.

Figure 64. Differential LVDS Sample Clock

Clock Duty Cycle Considerations

Typical high speed ADCs use both clock edges to generate a variety of internal timing signals. The AD6684 contains an internal clock divider and a duty cycle stabilizer (DCS). In applications where the clock duty cycle cannot be guaranteed to be 50%, a higher multiple frequency clock along with the usage of the clock divider is recommended. When it is not possible to provide a higher frequency clock, it is recommended to turn on the DCS using Register 0x011C. The output of the divider offers a 50% duty cycle, high slew rate (fast edge) clock signal to the internal ADC. See the Memory Map section for more details on using this feature.

Input Clock Divider

The AD6684 contains an input clock divider with the ability to divide the input clock by 1, 2, 4, and 8. The divider ratios can be selected using Register 0x0108 (see Figure 65).

In applications where the clock input is a multiple of the sample clock, care must be taken to program the appropriate divider ratio into the clock divider before applying the clock signal. This ratio ensures that the current transients during device startup are controlled.

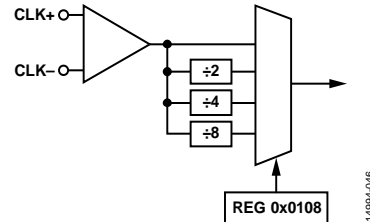

Figure 65. Clock Divider Circuit

The AD6684 clock divider can be synchronized using the external SYSREF± input. A valid SYSREF± causes the clock divider to reset to a programmable state. This synchronization feature allows multiple devices to have their clock dividers aligned to guarantee simultaneous input sampling.

Clock Jitter Considerations

High speed, high resolution ADCs are sensitive to the quality of the clock input. The degradation in SNR at a given input frequency (f_A) due only to aperture jitter (t_j) can be calculated by

$$SNR = -20 \times \log (2 \times \pi \times f_A \times t_j)$$

In this equation, the rms aperture jitter represents the root mean square of all jitter sources, including the clock input, analog input signal, and ADC aperture jitter specifications. If undersampling applications are particularly sensitive to jitter (see Figure 66).

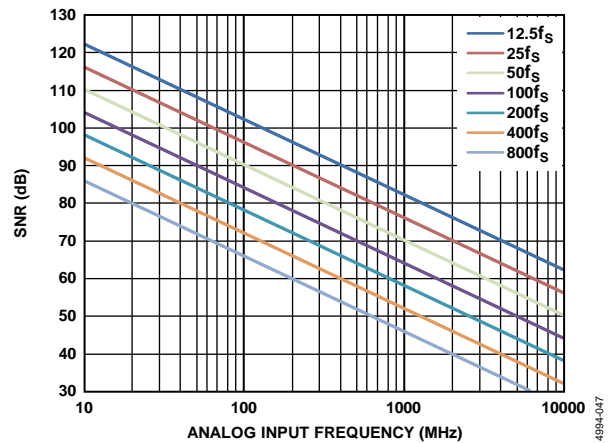

Figure 66. Ideal SNR vs. Analog Input Frequency and Jitter

Treat the clock input as an analog signal in cases where aperture jitter may affect the dynamic range of the AD6684. Separate the power supplies for clock drivers from the ADC output driver supplies to avoid modulating the clock signal with digital noise. If the clock is generated from another type of source (by gating, dividing, or other methods), retime the clock by the original clock at the last step. Refer to the [AN-501 Application Note](#) and the [AN-756 Application Note](#) for more in-depth information about jitter performance as it relates to ADCs.

Figure 66 shows the estimated SNR of the AD6684 across input frequency for different clock induced jitter values. The SNR can be estimated by using the following equation:

$$\text{SNR(dBFS)} = -10 \log \left(10^{\left(\frac{-\text{SNR}_{\text{ADC}}}{10} \right)} + 10^{\left(\frac{-\text{SNR}_{\text{JITTER}}}{10} \right)} \right)$$

Power-Down/Standby Mode

The AD6684 has a PDWN/STBY pin that can be used to configure the device in power-down or standby mode. The default operation is power-down. The PDWN/STBY pin is a logic high pin. When in power-down mode, the JESD204B link is disrupted. The power-down option can also be set via Register 0x003F and Register 0x0040.

In standby mode, the JESD204B link is not disrupted and transmits zeros for all converter samples. This setting can be changed using Register 0x0571, Bit 7 to select /K/ characters.

TEMPERATURE DIODE

The AD6684 contains a diode-based temperature sensor for measuring the temperature of the die. The diode can output a voltage and serve as a coarse temperature sensor to monitor the internal die temperature.

The temperature diode voltage can be output to the VCM_CD/VREF pin using the SPI. Use Register 0x18E6 to enable or disable the diode. Register 0x18E6 is a local register. Both cores must be selected in the core index register (Register 0x0009 = 0x03) to enable the temperature diode readout. It is important to note

that other voltages may be exported to the same pin at the same time, which may result in undefined behavior. Thus, to ensure a proper readout, switch off all other voltage exporting circuits as detailed in this section.

The SPI writes required to export the temperature diode are as follows (see Table 46 for more information):

1. Set Register 0x0009 to 0x03 to select both cores.
2. Set Register 0x18E3 to 0x00 to turn off VCM export.
3. Set Register 0x18A6 to 0x00 to turn off the voltage reference.
4. Set Register 0x18E6 to 0x01 to turn on temperature diode export. The typical voltage response of the temperature diode is shown in Figure 67. However, it is recommended to take measurements from a pair of diodes into account when introducing another step.
5. Set Register 0x18E6 to 0x02 to turn on the second temperature diode (that is, 20× the size) of the pair.

For the method utilizing two diodes simultaneously giving a more accurate result, see the [AN-1432 Application Note, Practical Thermal Modeling and Measurements in High Power ICs](#).

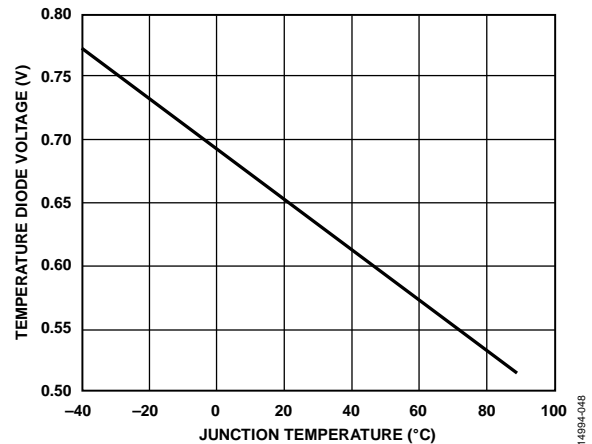

Figure 67. Temperature Diode Voltage vs. Junction Temperature

ADC OVERRANGE AND FAST DETECT

In receiver applications, it is desirable to have a mechanism to reliably determine when the converter is about to be clipped. The standard overrange bit in the JESD204B outputs provides information on the state of the analog input that is of limited usefulness. Therefore, it is helpful to have a programmable threshold below full scale that allows time to reduce the gain before the clip actually occurs. In addition, because input signals can have significant slew rates, the latency of this function is of major concern. Highly pipelined converters can have significant latency. The AD6684 contains fast detect circuitry for individual channels to monitor the threshold and to assert the FD_A, FD_B, FD_C, and FD_D pins.

ADC OVERRANGE

The ADC overrange indicator is asserted when an overrange is detected on the input of the ADC. The overrange indicator can be embedded within the JESD204B link as a control bit. The latency of this overrange indicator matches the sample latency.

FAST THRESHOLD DETECTION (FD_A, FD_B, FD_C AND FD_D)

The FD bits (Register 0x0040, Bits[5:0]) are immediately set whenever the absolute value of the input signal exceeds the programmable upper threshold level. The FD bits are only cleared when the absolute value of the input signal drops below the lower threshold level for greater than the programmable dwell time. This feature provides hysteresis and prevents the FD bits from excessively toggling.

The operation of the upper threshold and lower threshold registers, along with the dwell time registers, is shown in Figure 68.

The FD indicator is asserted if the input magnitude exceeds the value programmed in the fast detect upper threshold registers, located at Register 0x0247 and Register 0x0248. The selected threshold register is compared with the signal magnitude at the output of the ADC. The fast upper threshold detection has a latency of 30 clock cycles (maximum). The approximate upper threshold magnitude is defined by

$$\text{Upper Threshold Magnitude (dBFS)} = 20\log(\text{Threshold Magnitude}/2^{13})$$

The FD indicators are not cleared until the signal drops below the lower threshold for the programmed dwell time. The lower threshold is programmed in the fast detect lower threshold registers, located at Register 0x0249 and Register 0x024A. The fast detect lower threshold register is a 13-bit register that is compared with the signal magnitude at the output of the ADC. This comparison is subject to the ADC pipeline latency, but is accurate in terms of converter resolution. The lower threshold magnitude is defined by

$$\text{Lower Threshold Magnitude (dBFS)} = 20\log(\text{Threshold Magnitude}/2^{13})$$

For example, to set an upper threshold of -6 dBFS, write 0xFFF to Register 0x0247 and Register 0x0248. To set a lower threshold of -10 dBFS, write 0xA1D to Register 0x0249 and Register 0x024A.

The dwell time can be programmed from 1 to 65,535 sample clock cycles by placing the desired value in the fast detect dwell time registers, located at Register 0x024B and Register 0x024C. See the Memory Map section (Register 0x040, and Register 0x245 to Register 0x24C in Table 46) for more details.

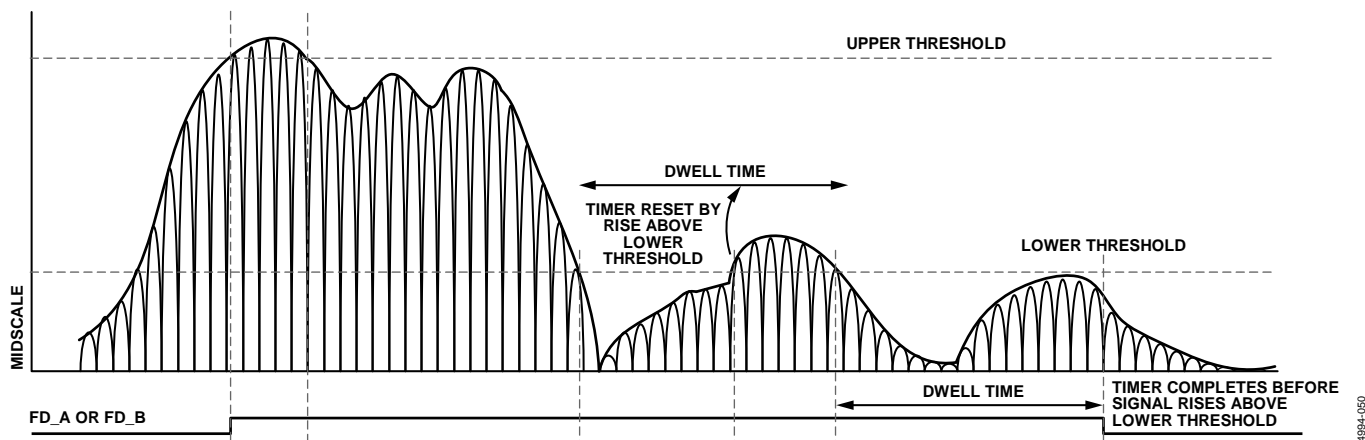

Figure 68. Threshold Settings for the FD_A and FD_B Signals

SIGNAL MONITOR

The signal monitor block provides additional information about the signal being digitized by the ADC. The signal monitor computes the peak magnitude of the digitized signal. This information can be used to drive an AGC loop to optimize the range of the ADC in the presence of real-world signals.

The results of the signal monitor block can be obtained either by reading back the internal values from the SPI port or by embedding the signal monitoring information into the JESD204B interface as special control bits. A global, 24-bit programmable period controls the duration of the measurement. Figure 69 shows the simplified block diagram of the signal monitor block.

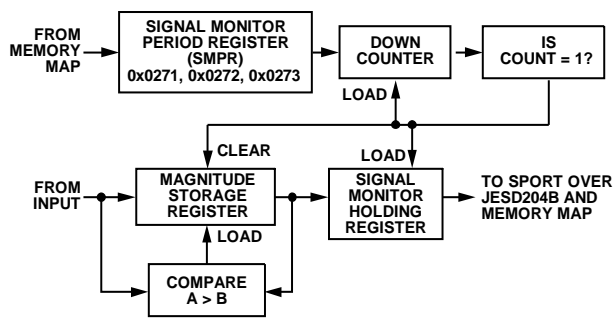

Figure 69. Signal Monitor Block

The peak detector captures the largest signal within the observation period. The detector only observes the magnitude of the signal. The resolution of the peak detector is a 13-bit value, and the observation period is 24 bits and represents converter output samples. The peak magnitude can be derived by using the following equation:

$$\text{Peak Magnitude (dBFS)} = 20 \log(\text{Peak Detector Value} / 2^{13})$$

The magnitude of the input port signal is monitored over a programmable time period, which is determined by the signal monitor period register (SMPR). The peak detector function is enabled by setting Bit 1 of Register 0x0270 in the signal monitor control register. The 24-bit SMPR must be programmed before activating this mode.

After enabling peak detection mode, the value in the SMPR is loaded into a monitor period timer, which decrements at the

decimated clock rate. The magnitude of the input signal is compared with the value in the internal magnitude storage register (not accessible to the user), and the greater of the two is updated as the current peak level. The initial value of the magnitude storage register is set to the current ADC input signal magnitude. This comparison continues until the monitor period timer reaches a count of 1.

When the monitor period timer reaches a count of 1, the 13-bit peak level value is transferred to the signal monitor holding register, which can be read through the memory map or output through the SPORT over the JESD204B interface. The monitor period timer is reloaded with the value in the SMPR, and the countdown restarts. In addition, the magnitude of the first input sample is updated in the magnitude storage register, and the comparison and update procedure, as explained previously, continues.

SPORT OVER JESD204B

The signal monitor data can also be serialized and sent over the JESD204B interface as control bits. These control bits must be deserialized from the samples to reconstruct the statistical data. The signal control monitor function is enabled by setting Bits[1:0] of Register 0x0279 and Bit 1 of Register 0x027A. Figure 70 shows two different example configurations for the signal monitor control bit locations inside the JESD204B samples. A maximum of three control bits can be inserted into the JESD204B samples; however, only one control bit is required for the signal monitor. Control bits are inserted from MSB to LSB. If only one control bit is to be inserted (CS = 1), only the most significant control bit is used (see Example Configuration 1 and Example Configuration 2 in Figure 70). To select the SPORT over JESD204B option, program Register 0x0559, Register 0x055A, and Register 0x058F. See Table 46 for more information on setting these bits.

Figure 71 shows the 25-bit frame data that encapsulates the peak detector value. The frame data is transmitted MSB first with five 5-bit subframes. Each subframe contains a start bit that can be used by a receiver to validate the deserialized data. Figure 72 shows the SPORT over JESD204B signal monitor data with a monitor period timer set to 80 samples.

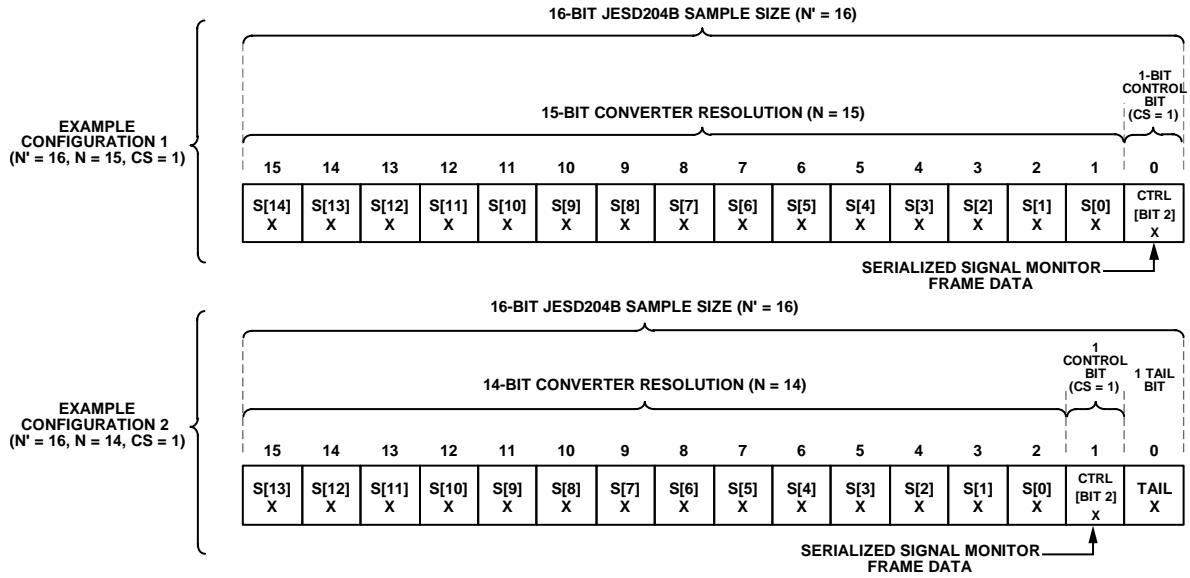

Figure 70. Signal Monitor Control Bit Locations

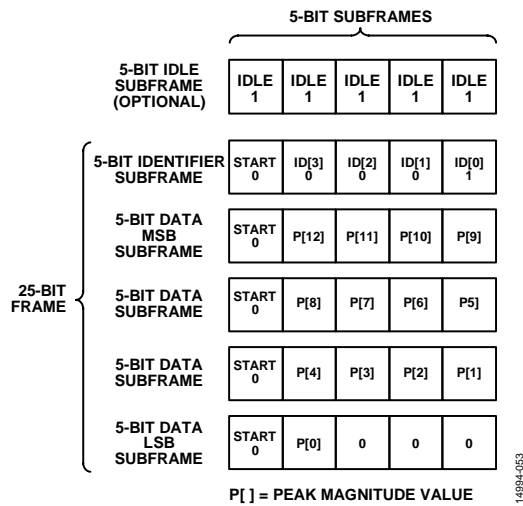
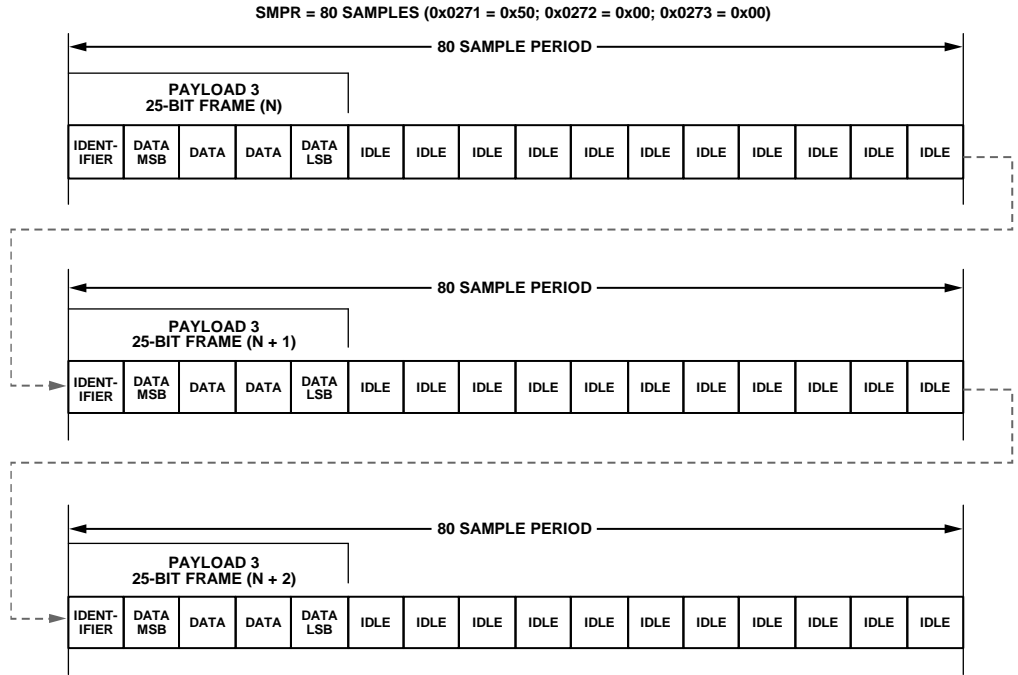

Figure 71. SPORT over JESD204B Signal Monitor Frame Data



14694-054

Figure 72. SPORT over JESD204B Signal Monitor Example with Period = 80 Samples

DIGITAL DOWNCONVERTER (DDC)

The AD6684 includes four DDCs that provide filtering and reduce the output data rate. This digital processing section includes an NCO, a half-band decimating filter, a finite impulse response (FIR) filter, a gain stage, and a complex to real conversion stage. Each of these processing blocks has control lines that allow it to be independently enabled and disabled to provide the desired processing function. Each pair of ADC channels has two DDCs (DDC0 and DDC1) for a total of four DDCs. The digital down-converter can be configured to output either real data or complex output data.

The DDCs output a 16-bit stream. To enable this operation, the converter number of bits, N , is set to a default value of 16, even though the analog core only outputs 14 bits. In full bandwidth operation, the ADC outputs are 9-bit words followed by seven zeros, unless the tail bits are enabled.

DDC I/Q INPUT SELECTION

The AD6684 has four ADC channels and four DDC channels. Each DDC channel has two input ports that can be paired to support both real and complex inputs through the I/Q crossbar mux. For real signals, both DDC input ports must select the same ADC channel (that is, DDC Input Port I = ADC Channel A and DDC Input Port Q = ADC Channel A). For complex signals, each DDC input port must select different ADC channels (that is, DDC Input Port I = ADC Channel A and DDC Input Port Q = ADC Channel B, or DDC Input Port I = ADC Channel C and DDC Input Port Q = ADC Channel D).

The inputs to each DDC are controlled by the DDC input selection registers (Register 0x0311 and Register 0x0331) in conjunction with the pair index register (Register 0x0009). See Table 46 for information on how to configure the DDCs.

DDC I/Q OUTPUT SELECTION

Each DDC channel has two output ports that can be paired to support both real and complex outputs. For real output signals, only the DDC Output Port I is used (the DDC Output Port Q is invalid). For complex I/Q output signals, both DDC Output Port I and DDC Output Port Q are used.

The I/Q outputs to each DDC channel are controlled by the DDC complex to real enable bit, Bit 3 in the DDC control registers (Register 0x0310 and Register 0x0330) in conjunction with the pair index register (Register 0x0009).

The Chip Q ignore bit in the chip mode register (Register 0x0200, Bit 5) controls the chip output muxing of all the DDC channels. When all DDC channels use real outputs, set this bit high to ignore all DDC Q output ports. When any of the DDC channels are set to use complex I/Q outputs, the user must clear this bit to use both DDC Output Port I and DDC Output Port Q. For more information, see Figure 81.

DDC GENERAL DESCRIPTION

The four DDC blocks are used to extract a portion of the full digital spectrum captured by the ADC(s). The DDC blocks are intended for IF sampling or oversampled baseband radios requiring wide bandwidth input signals.

Each DDC block contains the following signal processing stages:

- Frequency translation stage (optional)
- Filtering stage
- Gain stage (optional)
- Complex to real conversion stage (optional)

Frequency Translation Stage (Optional)

This stage consists of a 48-bit complex NCO and quadrature mixers that can be used for frequency translation of both real and complex input signals. This stage shifts a portion of the available digital spectrum down to baseband.

Filtering Stage

After shifting down to baseband, this stage decimates the frequency spectrum using a chain of up to four half-band, low-pass filters for rate conversion. The decimation process lowers the output data rate, which in turn reduces the output interface rate.

Gain Stage (Optional)

To compensate for losses associated with mixing a real input signal down to baseband, this stage adds an additional 0 dB or 6 dB of gain.

Complex to Real Conversion Stage (Optional)

When real outputs are necessary, this stage converts the complex outputs back to real by performing an $f_s/4$ mixing operation plus a filter to remove the complex component of the signal.

Figure 73 shows the detailed block diagram of the DDCs implemented in the AD6684.

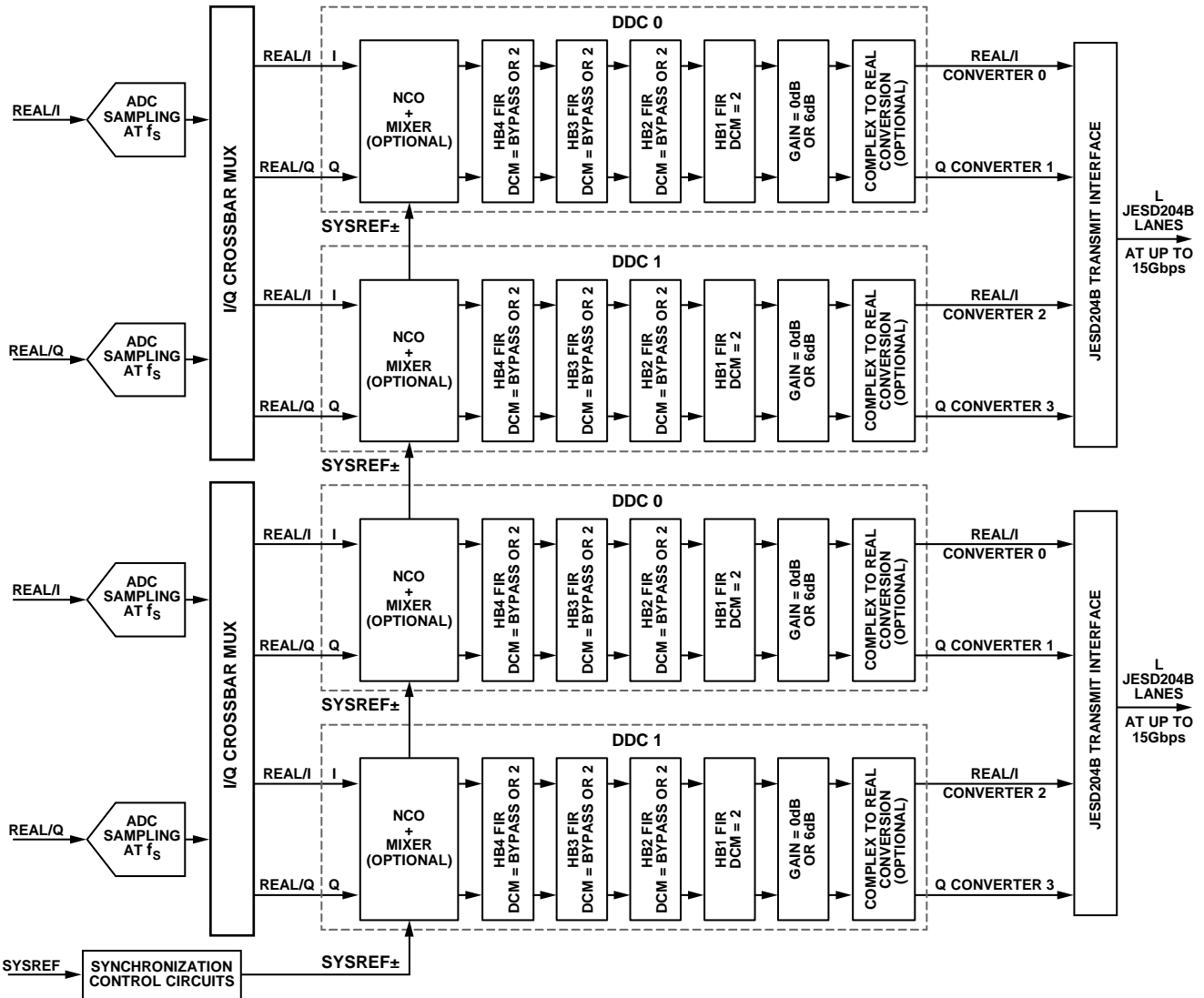

Figure 73. DDC Detailed Block Diagram

Figure 74 shows an example usage of one of the four DDC blocks with a real input signal and four half-band filters (HB4 + HB3 + HB2 + HB1). It shows both complex (decimate by 16) and real (decimate by 8) output options.

When DDCs have different decimation ratios, the chip decimation ratio (Register 0x0201) must be set to the lowest decimation ratio of all the DDC blocks on a per pair basis in conjunction with the pair index (Register 0x0009). In this scenario, samples of higher decimation ratio DDCs are repeated to match the chip decimation ratio sample rate. Whenever the NCO frequency is set or changed, the DDC soft reset must be

issued. If the DDC soft reset is not issued, the output may potentially show amplitude variations.

Table 10, Table 11, Table 12, Table 13, and Table 14 show the DDC samples when the chip decimation ratio is set to 1, 2, 4, 8, or 16, respectively. When DDCs have different decimation ratios, the chip decimation ratio must be set to the lowest decimation ratio of all the DDC channels in the respective channel pair (Channel A/Channel B or Channel C/Channel D). In this scenario, samples of higher decimation ratio DDCs are repeated to match the chip decimation ratio sample rate.

14-994-065

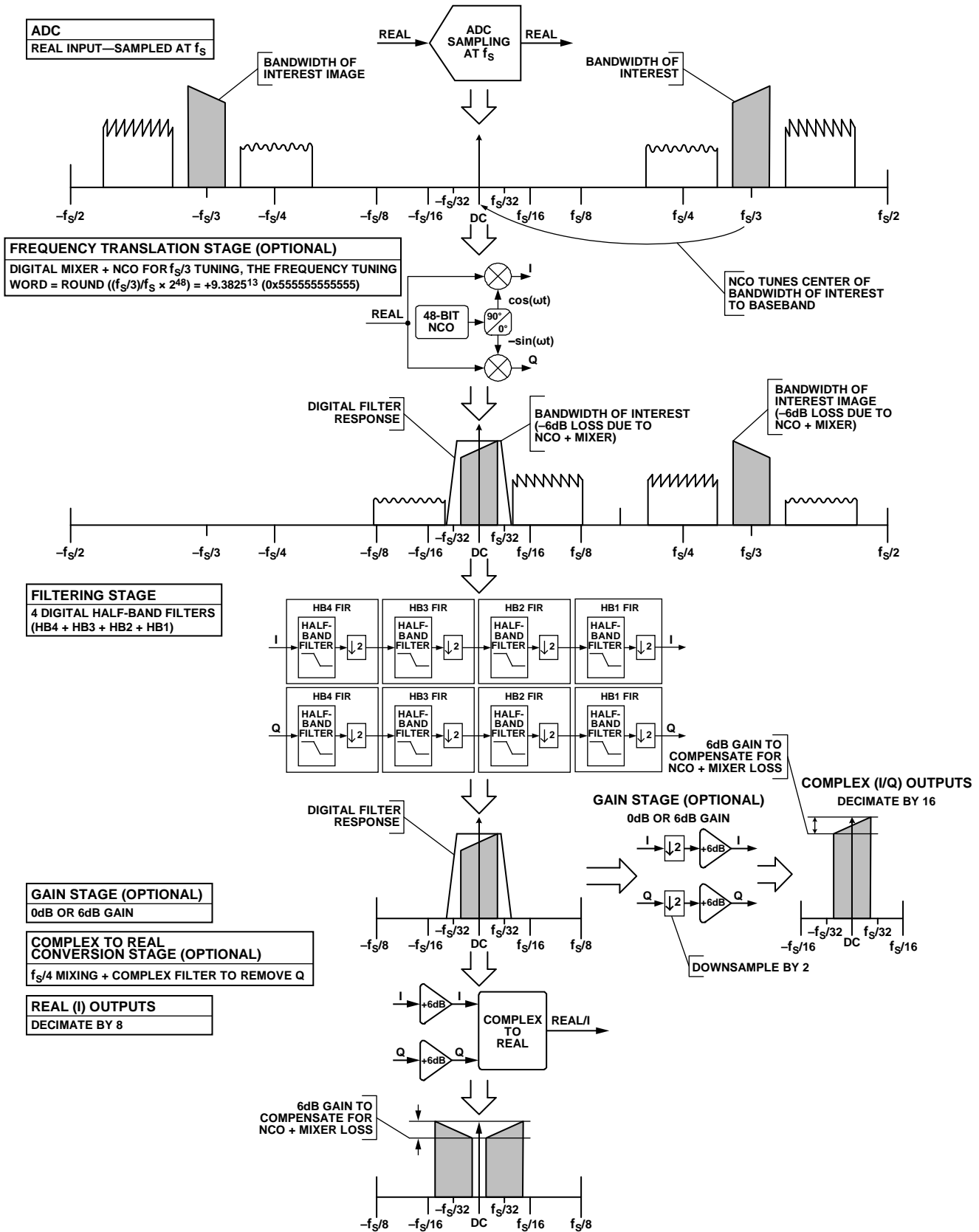

Figure 74. DDC Theory of Operation Example (Real Input, Decimate by 16)

Table 10. DDC Samples in Each JESD204B Link When Chip Decimation Ratio = 1

Real (I) Output (Complex to Real Enabled)				Complex (I/Q) Outputs (Complex to Real Disabled)			
HB1 FIR (DCM ¹ = 1)	HB2 FIR + HB1 FIR (DCM ¹ = 2)	HB3 FIR + HB2 FIR + HB1 FIR (DCM ¹ = 4)	HB4 FIR + HB3 FIR + HB2 FIR + HB1 FIR (DCM ¹ = 8)	HB1 FIR (DCM ¹ = 2)	HB2 FIR + HB1 FIR (DCM ¹ = 4)	HB3 FIR + HB2 FIR + HB1 FIR (DCM ¹ = 8)	HB4 FIR + HB3 FIR + HB2 FIR + HB1 FIR (DCM ¹ = 16)
N	N	N	N	N	N	N	N
N + 1	N	N	N	N	N	N	N
N + 2	N + 1	N	N	N + 1	N	N	N
N + 3	N + 1	N	N	N + 1	N	N	N
N + 4	N + 2	N + 1	N	N + 2	N + 1	N	N
N + 5	N + 2	N + 1	N	N + 2	N + 1	N	N
N + 6	N + 3	N + 1	N	N + 3	N + 1	N	N
N + 7	N + 3	N + 1	N	N + 3	N + 1	N	N
N + 8	N + 4	N + 2	N + 1	N + 4	N + 2	N + 1	N
N + 9	N + 4	N + 2	N + 1	N + 4	N + 2	N + 1	N
N + 10	N + 5	N + 2	N + 1	N + 5	N + 2	N + 1	N
N + 11	N + 5	N + 2	N + 1	N + 5	N + 2	N + 1	N
N + 12	N + 6	N + 3	N + 1	N + 6	N + 3	N + 1	N
N + 13	N + 6	N + 3	N + 1	N + 6	N + 3	N + 1	N
N + 14	N + 7	N + 3	N + 1	N + 7	N + 3	N + 1	N
N + 15	N + 7	N + 3	N + 1	N + 7	N + 3	N + 1	N
N + 16	N + 8	N + 4	N + 2	N + 8	N + 4	N + 2	N + 1
N + 17	N + 8	N + 4	N + 2	N + 8	N + 4	N + 2	N + 1
N + 18	N + 9	N + 4	N + 2	N + 9	N + 4	N + 2	N + 1
N + 19	N + 9	N + 4	N + 2	N + 9	N + 4	N + 2	N + 1
N + 20	N + 10	N + 5	N + 2	N + 10	N + 5	N + 2	N + 1
N + 21	N + 10	N + 5	N + 2	N + 10	N + 5	N + 2	N + 1
N + 22	N + 11	N + 5	N + 2	N + 11	N + 5	N + 2	N + 1
N + 23	N + 11	N + 5	N + 2	N + 11	N + 5	N + 2	N + 1
N + 24	N + 12	N + 6	N + 3	N + 12	N + 6	N + 3	N + 1
N + 25	N + 12	N + 6	N + 3	N + 12	N + 6	N + 3	N + 1
N + 26	N + 13	N + 6	N + 3	N + 13	N + 6	N + 3	N + 1
N + 27	N + 13	N + 6	N + 3	N + 13	N + 6	N + 3	N + 1
N + 28	N + 14	N + 7	N + 3	N + 14	N + 7	N + 3	N + 1
N + 29	N + 14	N + 7	N + 3	N + 14	N + 7	N + 3	N + 1
N + 30	N + 15	N + 7	N + 3	N + 15	N + 7	N + 3	N + 1
N + 31	N + 15	N + 7	N + 3	N + 15	N + 7	N + 3	N + 1

¹ DCM means decimation.

Table 11. DDC Samples in Each JESD204B Link When Chip Decimation Ratio = 2

Real (I) Output (Complex to Real Enabled)			Complex (I/Q) Outputs (Complex to Real Disabled)			
HB2 FIR + HB1 FIR (DCM ¹ = 2)	HB3 FIR + HB2 FIR + HB1 FIR (DCM ¹ = 4)	HB4 FIR + HB3 FIR + HB2 FIR + HB1 FIR (DCM ¹ = 8)	HB1 FIR (DCM ¹ = 2)	HB2 FIR + HB1 FIR (DCM ¹ = 4)	HB3 FIR + HB2 FIR + HB1 FIR (DCM ¹ = 8)	HB4 FIR + HB3 FIR + HB2 FIR + HB1 FIR (DCM ¹ = 16)
N	N	N	N	N	N	N
N + 1	N	N	N + 1	N	N	N
N + 2	N + 1	N	N + 2	N + 1	N	N
N + 3	N + 1	N	N + 3	N + 1	N	N
N + 4	N + 2	N + 1	N + 4	N + 2	N + 1	N
N + 5	N + 2	N + 1	N + 5	N + 2	N + 1	N
N + 6	N + 3	N + 1	N + 6	N + 3	N + 1	N
N + 7	N + 3	N + 1	N + 7	N + 3	N + 1	N
N + 8	N + 4	N + 2	N + 8	N + 4	N + 2	N + 1
N + 9	N + 4	N + 2	N + 9	N + 4	N + 2	N + 1

Real (I) Output (Complex to Real Enabled)			Complex (I/Q) Outputs (Complex to Real Disabled)			
HB2 FIR + HB1 FIR (DCM ¹ = 2)	HB3 FIR + HB2 FIR + HB1 FIR (DCM ¹ = 4)	HB4 FIR + HB3 FIR + HB2 FIR + HB1 FIR (DCM ¹ = 8)	HB1 FIR (DCM ¹ = 2)	HB2 FIR + HB1 FIR (DCM ¹ = 4)	HB3 FIR + HB2 FIR + HB1 FIR (DCM ¹ = 8)	HB4 FIR + HB3 FIR + HB2 FIR + HB1 FIR (DCM ¹ = 16)
N + 10	N + 5	N + 2	N + 10	N + 5	N + 2	N + 1
N + 11	N + 5	N + 2	N + 11	N + 5	N + 2	N + 1
N + 12	N + 6	N + 3	N + 12	N + 6	N + 3	N + 1
N + 13	N + 6	N + 3	N + 13	N + 6	N + 3	N + 1
N + 14	N + 7	N + 3	N + 14	N + 7	N + 3	N + 1
N + 15	N + 7	N + 3	N + 15	N + 7	N + 3	N + 1

¹ DCM means decimation.

Table 12. DDC Samples in Each JESD204B Link When Chip Decimation Ratio = 4

Real (I) Output (Complex to Real Enabled)		Complex (I/Q) Outputs (Complex to Real Disabled)		
HB3 FIR + HB2 FIR + HB1 FIR (DCM ¹ = 4)	HB4 FIR + HB3 FIR + HB2 FIR + HB1 FIR (DCM ¹ = 8)	HB2 FIR + HB1 FIR (DCM ¹ = 4)	HB3 FIR + HB2 FIR + HB1 FIR (DCM ¹ = 8)	HB4 FIR + HB3 FIR + HB2 FIR + HB1 FIR (DCM ¹ = 16)
N	N	N	N	N
N + 1	N	N + 1	N	N
N + 2	N + 1	N + 2	N + 1	N
N + 3	N + 1	N + 3	N + 1	N
N + 4	N + 2	N + 4	N + 2	N + 1
N + 5	N + 2	N + 5	N + 2	N + 1
N + 6	N + 3	N + 6	N + 3	N + 1
N + 7	N + 3	N + 7	N + 3	N + 1

¹ DCM means decimation.

Table 13. DDC Samples in Each JESD204B Link When Chip Decimation Ratio = 8

Real (I) Output (Complex to Real Enabled)	Complex (I/Q) Outputs (Complex to Real Disabled)	
HB4 FIR + HB3 FIR + HB2 FIR + HB1 FIR (DCM ¹ = 8)	HB3 FIR + HB2 FIR + HB1 FIR (DCM ¹ = 8)	HB4 FIR + HB3 FIR + HB2 FIR + HB1 FIR (DCM ¹ = 16)
N	N	N
N + 1	N + 1	N
N + 2	N + 2	N + 1
N + 3	N + 3	N + 1
N + 4	N + 4	N + 2
N + 5	N + 5	N + 2
N + 6	N + 6	N + 3
N + 7	N + 7	N + 3

¹ DCM means decimation.

Table 14. DDC Samples in Each JESD204B Link When Chip Decimation Ratio = 16

Real (I) Output (Complex to Real Enabled)	Complex (I/Q) Outputs (Complex to Real Disabled)
HB4 FIR + HB3 FIR + HB2 FIR + HB1 FIR (DCM ¹ = 16)	HB4 FIR + HB3 FIR + HB2 FIR + HB1 FIR (DCM ¹ = 16)
Not applicable	N
Not applicable	N + 1
Not applicable	N + 2
Not applicable	N + 3

¹ DCM means decimation.

For example, if the chip decimation ratio is set to decimate by 4, DDC 0 is set to use HB2 + HB1 filters (complex outputs, decimate by 4) and DDC 1 is set to use HB4 + HB3 + HB2 + HB1 filters

(real outputs, decimate by 8). DDC 1 repeats its output data two times for every one DDC 0 output. The resulting output samples are shown in Table 15.

Table 15. DDC Output Samples in Each JESD204B Link When Chip DCM¹ = 4, DDC 0 DCM¹ = 4 (Complex), and DDC 1 DCM¹ = 8 (Real)

DDC Input Samples	DDC 0		DDC 1	
	Output Port I	Output Port Q	Output Port I	Output Port Q
N	I0 (N)	Q0 (N)	I1 (N)	Not applicable
N + 1				
N + 2				
N + 3				
N + 4	I0 (N + 1)	Q0 (N + 1)		
N + 5				
N + 6				
N + 7				
N + 8	I0 (N + 2)	Q0 (N + 2)	I1 (N + 1)	Not applicable
N + 9				
N + 10				
N + 11				
N + 12	I0 (N + 3)	Q0 (N + 3)		
N + 13				
N + 14				
N + 15				

¹ DCM means decimation.

FREQUENCY TRANSLATION

GENERAL DESCRIPTION

Frequency translation is accomplished by using a 48-bit complex NCO with a digital quadrature mixer. This stage translates either a real or complex input signal from an IF to a baseband complex digital output (carrier frequency = 0 Hz).

The frequency translation stage of each DDC can be controlled individually and supports four different IF modes using Bits[5:4] of the DDC control registers (Register 0x0310 and Register 0x0330) in conjunction with the pair index register (Register 0x0009). These IF modes are

- Variable IF mode
- 0 Hz IF or zero IF (ZIF) mode
- $f_s/4$ Hz IF mode
- Test mode

Variable IF Mode

NCO and mixers are enabled. NCO output frequency can be used to digitally tune the IF frequency.

0 Hz IF (ZIF) Mode

The mixers are bypassed, and the NCO is disabled.

$f_s/4$ Hz IF Mode

The mixers and the NCO are enabled in special downmixing by $f_s/4$ mode to save power.

Test Mode

Input samples are forced to 0.9599 to positive full scale. The NCO is enabled. This test mode allows the NCOs to directly drive the decimation filters.

Figure 75 and Figure 76 show examples of the frequency translation stage for both real and complex inputs.

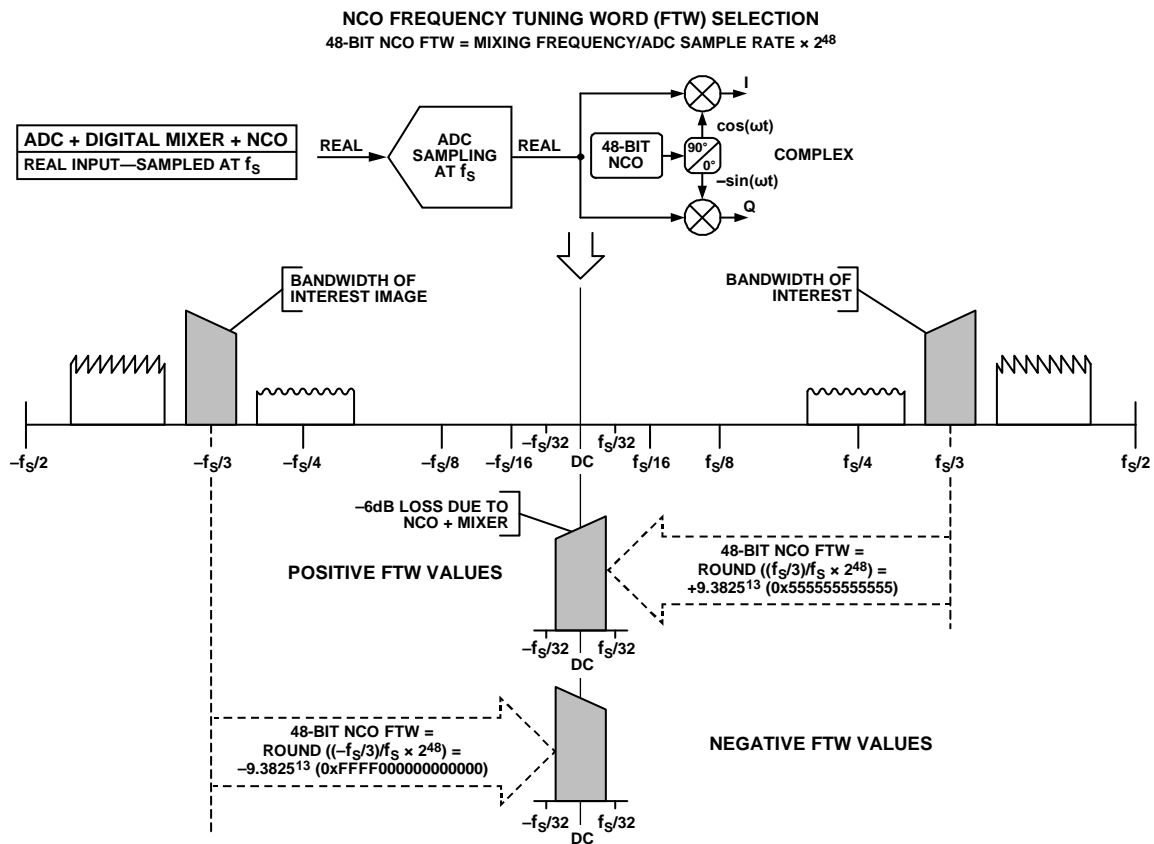

Figure 75. DDC NCO Frequency Tuning Word Selection—Real Inputs

14994-057

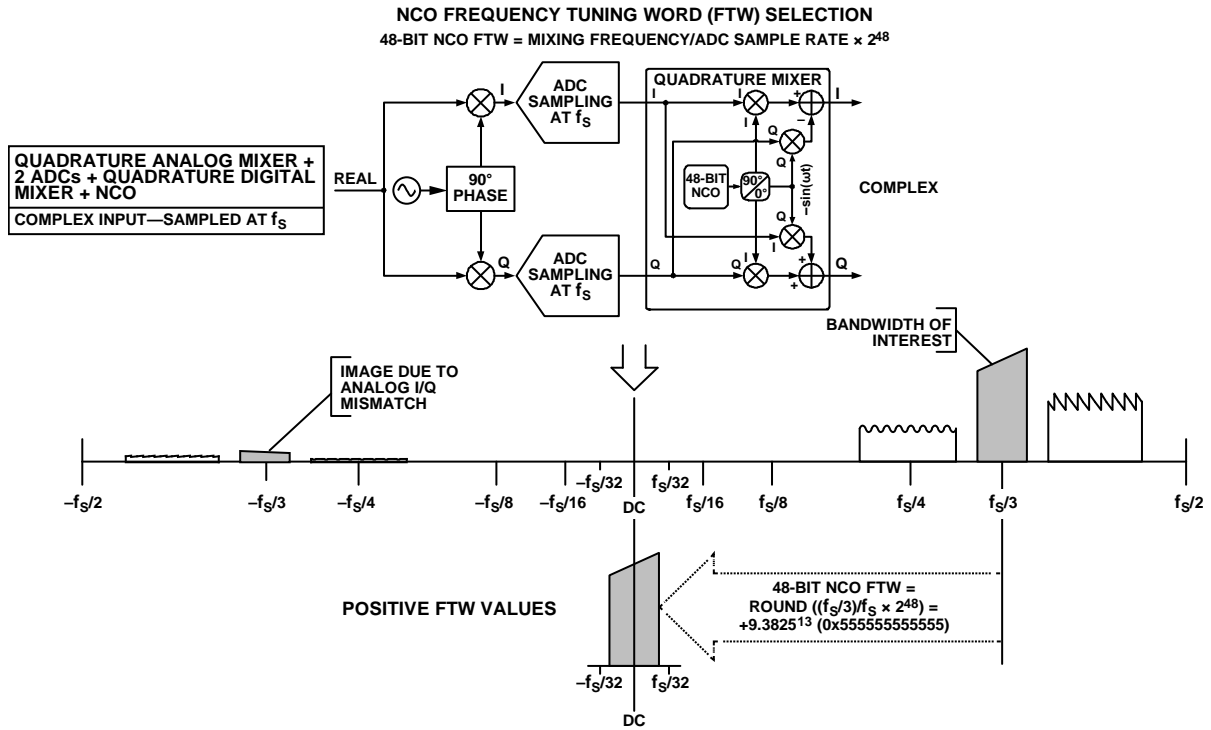

Figure 76. DDC NCO Frequency Tuning Word Selection—Complex Inputs

DDC NCO + MIXER LOSS AND SFDR

When mixing a real input signal down to baseband, 6 dB of loss is introduced in the signal due to filtering of the negative image. An additional 0.05 dB of loss is introduced by the NCO. The total loss of a real input signal mixed down to baseband is 6.05 dB. For this reason, it is recommended that the user compensate for this loss by enabling the 6 dB of gain in the gain stage of the DDC to recenter the dynamic range of the signal within the full scale of the output bits.

When mixing a complex input signal down to baseband, the maximum value that each I/Q sample can reach is 1.414 × full scale after it passes through the complex mixer. To avoid over-range of the I/Q samples and to keep the data bit widths aligned with real mixing, 3.06 dB of loss is introduced in the mixer for complex signals. An additional 0.05 dB of loss is introduced by the NCO. The total loss of a complex input signal mixed down to baseband is -3.11 dB.

The worst case spurious signal from the NCO is greater than 102 dBc SFDR for all output frequencies.

NUMERICALLY CONTROLLED OSCILLATOR

The AD6684 has a 48-bit NCO for each DDC that enables the frequency translation process. The NCO allows the input spectrum to be tuned to dc, where it can be effectively filtered by the subsequent filter blocks to prevent aliasing. The NCO can be set up by providing a frequency tuning word (FTW) and a phase offset word (POW).

Setting Up the NCO FTW and POW

The NCO frequency value is given by the 48-bit twos complement number entered in the NCO FTW. Frequencies between -fs/2 and +fs/2 (fs/2 excluded) are represented using the following frequency words:

- 0x8000 0000 0000 represents a frequency of -fs/2.
- 0x0000 0000 0000 represents dc (frequency is 0 Hz).
- 0x7FFF FFFF FFFF represents a frequency of +fs/2 - fs/2⁴⁸.

The NCO frequency tuning word can be calculated using the following equation:

$$NCO_FTW = round\left(2^{48} \frac{mod(f_c, f_s)}{f_s}\right)$$

where:

NCO_FTW is a 48-bit twos complement number representing the NCO FTW.

f_c is the desired carrier frequency in Hz.

f_s is the AD6684 sampling frequency (clock rate) in Hz.

mod() is a remainder function. For example, mod(110,100) = 10 and for negative numbers, mod(-32, 10) = -2.

round() is a rounding function. For example, round(3.6) = 4 and for negative numbers, round(-3.4) = -3.

Note that this equation applies to the aliasing of signals in the digital domain (that is, aliasing introduced when digitizing analog signals).

For example, if the ADC sampling frequency (f_s) is 500 MSPS and the carrier frequency (f_c) is 140.312 MHz, then

$$NCO_FTW = \text{round} \left(2^{48} \frac{\text{mod}(140.312, 500)}{500} \right) = 7.89886 \times 10^{13} \text{ Hz}$$

This, in turn, converts to 0x47D in the 48-bit twos complement representation for NCO_FTW . The actual carrier frequency, f_{c_ACTUAL} , is calculated based on the following equation:

$$f_{c_ACTUAL} = \frac{NCO_FTW \times f_s}{2^{48}} = 140.312 \text{ MHz}$$

A 48-bit POW is available for each NCO to create a known phase relationship between multiple AD6684 chips or individual DDC channels inside one AD6684 chip.

The POW registers can be updated in the NCO at any time without disrupting the phase accumulators, allowing phase adjustments to occur during normal operation. However, the following procedure must be followed to update the FTW registers to ensure proper operation of the NCO:

1. Write to the FTW registers for all the DDCs.
2. Synchronize the NCOs either through the DDC NCO soft reset bit (Register 0x0300, Bit 4), which is accessible through the SPI, or through the assertion of the SYSREF± pin.

It is important to note that the NCOs must be synchronized either through the SPI or through the SYSREF± pin after all writes to the FTW or POW registers are complete. This step is necessary to ensure the proper operation of the NCO.

NCO Synchronization

Each NCO contains a separate phase accumulator word (PAW). The initial reset value of each PAW is set to zero, and the phase increment value of each PAW is determined by the FTW. The POW is added to the PAW to produce the instantaneous phase

of the NCO. See the Setting Up the NCO FTW and POW section for more information.

Use the following two methods to synchronize multiple PAWs within the chip.

- Using the SPI. Use the DDC NCO soft reset bit in the DDC synchronization control register (Register 0x0300, Bit 4) to reset all the PAWs in the chip. This is accomplished by setting the DDC NCO soft reset bit high and then setting this bit low. Note that this method can only be used to synchronize DDC channels within the same pair (A/B or C/D) of a AD6684 chip.
- Using the SYSREF± pin. When the SYSREF± pin is enabled in the SYSREF± control registers (Register 0x0120 and Register 0x0121) and the DDC synchronization is enabled in the DDC synchronization control register (Register 0x0300, Bits[1:0]), any subsequent SYSREF± event resets all the PAWs in the chip. Note that this method can be used to synchronize DDC channels within the same AD6684 chip or DDC channels within separate AD6684 chips.

Mixer

The NCO is accompanied by a mixer. Its operation is similar to an analog quadrature mixer. It performs the downconversion of input signals (real or complex) by using the NCO frequency as a local oscillator. For real input signals, this mixer performs a real mixer operation (with two multipliers). For complex input signals, the mixer performs a complex mixer operation (with four multipliers and two adders). The mixer adjusts its operation based on the input signal (real or complex) provided to each individual channel. The selection of real or complex inputs can be controlled individually for each DDC block using Bit 7 of the DDC control registers (Register 0x0310 and Register 0x0330) in conjunction with the pair index register (Register 0x0009).

FIR FILTERS

GENERAL DESCRIPTION

There are four sets of decimate by 2, low-pass, half-band, FIR filters (labeled HB1 FIR, HB2 FIR, HB3 FIR, and HB4 FIR in Figure 73) following the frequency translation stage. After the carrier of interest is tuned down to dc (carrier frequency = 0 Hz), these filters efficiently lower the sample rate, while providing sufficient alias rejection from unwanted adjacent carriers around the bandwidth of interest.

HB1 FIR is always enabled and cannot be bypassed. The HB2, HB3, and HB4 FIR filters are optional and can be bypassed for higher output sample rates.

Table 16 shows the different bandwidths selectable by including different half-band filters. In all cases, the DDC filtering stage on the AD6684 provides <-0.001 dB of pass-band ripple and >100 dB of stop-band alias rejection.

Table 17 shows the amount of stop-band alias rejection for multiple pass-band ripple/cutoff points. The decimation ratio of the filtering stage of each DDC can be controlled individually through Bits[1:0] of the DDC control registers (Register 0x0310 and Register 0x0330) in conjunction with the pair index register (Register 0x0009).

Table 16. DDC Filter Characteristics

Half Band Filter Selection	Real Output		Complex (I/Q) Output		Alias Protected Bandwidth (MHz)	Ideal SNR Improvement ¹ (dB)	Pass-Band Ripple (dB)	Alias Rejection (dB)
	Decimation Ratio	Output Sample Rate (MSPS)	Decimation Ratio	Output Sample Rate (MSPS)				
HB1	1	500	2	250 (I) + 250 (Q)	200	1	<-0.0001	>100
HB1 + HB2	2	250	4	125 (I) + 125 (Q)	100	4		
HB1 + HB2 + HB3	4	125	8	62.5 (I) + 62.5 (Q)	50	7		
HB1 + HB2 + HB3 + HB4	8	62.5	16	31.25 (I) + 31.25 (Q)	25	10		

¹ Ideal SNR improvement due to oversampling and filtering = $10\log(\text{bandwidth}/(f_s/2))$.

Table 17. DDC Filter Alias Rejection

Alias Rejection (dB)	Pass-Band Ripple/Cutoff Point (dB)	Alias Protected Bandwidth for Real (I) Outputs ¹	Alias Protected Bandwidth for Complex (I/Q) Outputs
>100	<-0.0001	$<40\% \times f_{\text{OUT}}$	$<80\% \times f_{\text{OUT}}$
95	<-0.0002	$<40.12\% \times f_{\text{OUT}}$	$<80.12\% \times f_{\text{OUT}}$
90	<-0.0003	$<40.23\% \times f_{\text{OUT}}$	$<80.46\% \times f_{\text{OUT}}$
85	<-0.0005	$<40.36\% \times f_{\text{OUT}}$	$<80.72\% \times f_{\text{OUT}}$
80	<-0.0009	$<40.53\% \times f_{\text{OUT}}$	$<81.06\% \times f_{\text{OUT}}$
25.07	-0.5	$45.17\% \times f_{\text{OUT}}$	$90.34\% \times f_{\text{OUT}}$
19.3	-1.0	$46.2\% \times f_{\text{OUT}}$	$92.4\% \times f_{\text{OUT}}$
10.7	-3.0	$48.29\% \times f_{\text{OUT}}$	$96.58\% \times f_{\text{OUT}}$

¹ $f_{\text{OUT}} = \text{ADC input sample rate} \div \text{DDC decimation}$.

HALF-BAND FILTERS

The AD6684 offers four half-band filters to enable digital signal processing of the ADC converted data. These half-band filters are bypassable and can be individually selected.

HB4 Filter

The first decimate by 2, half-band, low-pass, FIR filter (HB4) uses an 11-tap, symmetrical, fixed coefficient filter implementation that is optimized for low power consumption. The HB4 filter is only used when complex outputs (decimate by 16) or real outputs (decimate by 8) are enabled; otherwise, it is bypassed. Table 18 and Figure 77 show the coefficients and response of the HB4 filter.

Table 18. HB4 Filter Coefficients

HB4 Coefficient Number	Decimal Coefficient	Quantized Coefficient (15-Bit)
C1, C11	0.006042	99
C2, C10	0	0
C3, C9	-0.049377	-809
C4, C8	0	0
C5, C7	0.293334	4806
C6	0.500000	8192

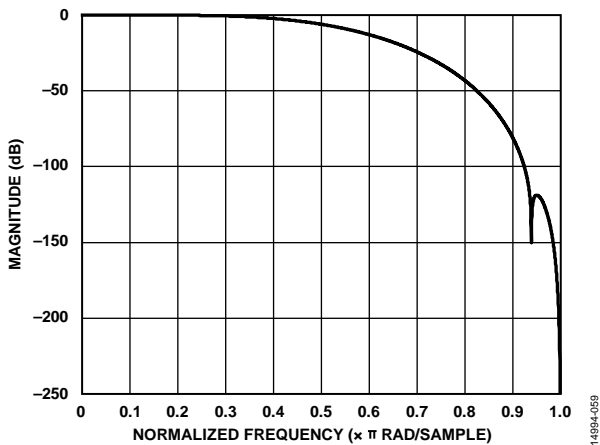

Figure 77. HB4 Filter Response

HB3 Filter

The second decimate by 2, half-band, low-pass, FIR filter (HB3) uses an 11-tap, symmetrical, fixed coefficient filter implementation that is optimized for low power consumption. The HB3 filter is only used when complex outputs (decimate by 8 or 16) or real outputs (decimate by 4 or 8) are enabled; otherwise, it is bypassed. Table 19 and Figure 78 show the coefficients and response of the HB3 filter.

Table 19. HB3 Filter Coefficients

HB3 Coefficient Number	Decimal Coefficient	Quantized Coefficient (17-Bit)
C1, C11	0.006638	435
C2, C10	0	0
C3, C9	-0.051055	-3,346
C4, C8	0	0
C5, C7	0.294418	19,295
C6	0.500000	32,768

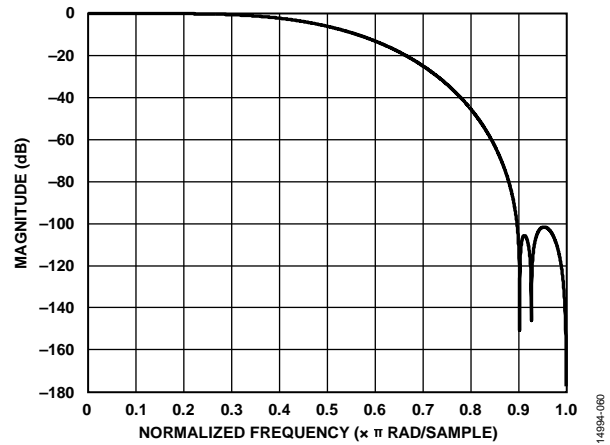

Figure 78. HB3 Filter Response

HB2 Filter

The third decimate by 2, half-band, low-pass, FIR filter (HB2) uses a 19-tap, symmetrical, fixed coefficient filter implementation that is optimized for low power consumption.

The HB2 filter is only used when complex or real outputs (decimate by 4, 8, or 16) is enabled; otherwise, it is bypassed.

Table 20 and Figure 79 show the coefficients and response of the HB2 filter.

Table 20. HB2 Filter Coefficients

HB2 Coefficient Number	Decimal Coefficient	Quantized Coefficient (18-Bit)
C1, C19	0.000671	88
C2, C18	0	0
C3, C17	-0.005325	-698
C4, C16	0	0
C5, C15	0.022743	2,981
C6, C14	0	0
C7, C13	-0.074181	-9,723
C8, C12	0	0
C9, C11	0.306091	40,120
C10	0.500000	65,536

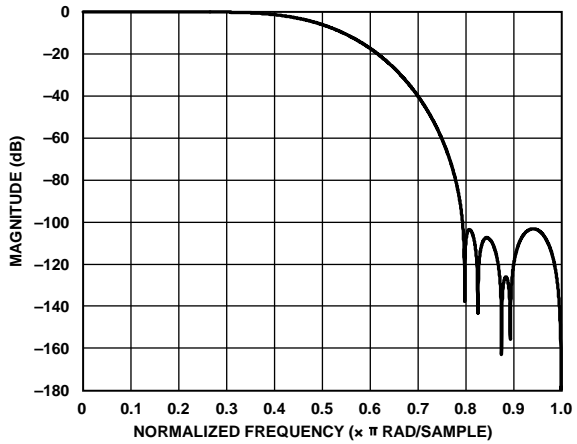

Figure 79. HB2 Filter Response

HB1 Filter

The fourth and final decimate by 2, half-band, low-pass, FIR filter (HB1) uses a 63-tap, symmetrical, fixed coefficient filter implementation that is optimized for low power consumption. The HB1 filter is always enabled and cannot be bypassed. Table 21 and Figure 80 show the coefficients and response of the HB1 filter.

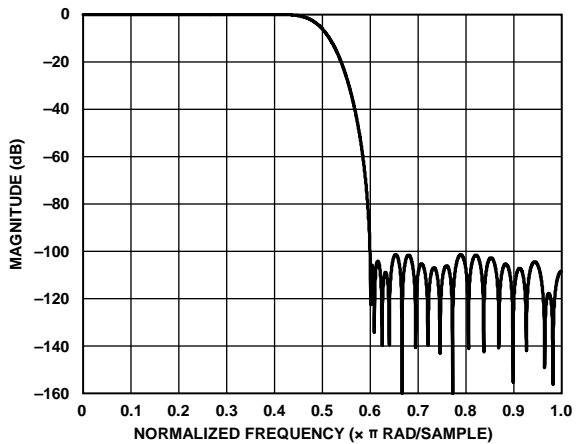

Figure 80. HB1 Filter Response

Table 21. HB1 Filter Coefficients

HB1 Coefficient Number	Decimal Coefficient	Quantized Coefficient (20-Bit)
C1, C63	-0.000019	-10
C2, C62	0	0
C3, C61	0.000072	38
C4, C60	0	0
C5, C59	-0.000194	-102
C6, C58	0	0
C7, C57	0.000442	232
C8, C56	0	0
C9, C55	-0.000891	-467
C10, C54	0	0
C11, C53	0.001644	862
C12, C52	0	0
C13, C51	-0.002840	-1,489
C14, C50	0	0
C15, C49	0.004653	2,440
C16, C48	0	0
C17, C47	-0.007311	-3,833
C18, C46	0	0
C19, C45	0.011121	5,831
C20, C44	0	0
C21, C43	-0.016553	-8,679
C22, C42	0	0
C23, C41	0.024420	12,803
C24, C40	0	0
C25, C39	-0.036404	-19,086
C26, C38	0	0
C27, C37	0.056866	29,814
C28, C36	0	0
C29, C35	-0.101892	-53,421
C30, C34	0	0
C31, C33	0.316883	166,138
C32	0.500000	262,144

DDC GAIN STAGE

Each DDC contains an independently controlled gain stage. The gain is selectable as either 0 dB or 6 dB. When mixing a real input signal down to baseband, it is recommended that the user enable the 6 dB of gain to recenter the dynamic range of the signal within the full scale of the output bits.

When mixing a complex input signal down to baseband, the mixer has already recentered the dynamic range of the signal within the full scale of the output bits, and no additional gain is necessary. However, the optional 6 dB gain compensates for low signal strengths. The downsample by 2 portion of the HB1 FIR filter is bypassed when using the complex to real conversion stage.

DDC COMPLEX TO REAL CONVERSION

Each DDC contains an independently controlled complex to real conversion block. The complex to real conversion block reuses the last filter (HB1 FIR) in the filtering stage along with an $f_s/4$ complex mixer to upconvert the signal. After upconverting the signal, the Q portion of the complex mixer is no longer needed and is dropped.

Figure 81 shows a simplified block diagram of the complex to real conversion.

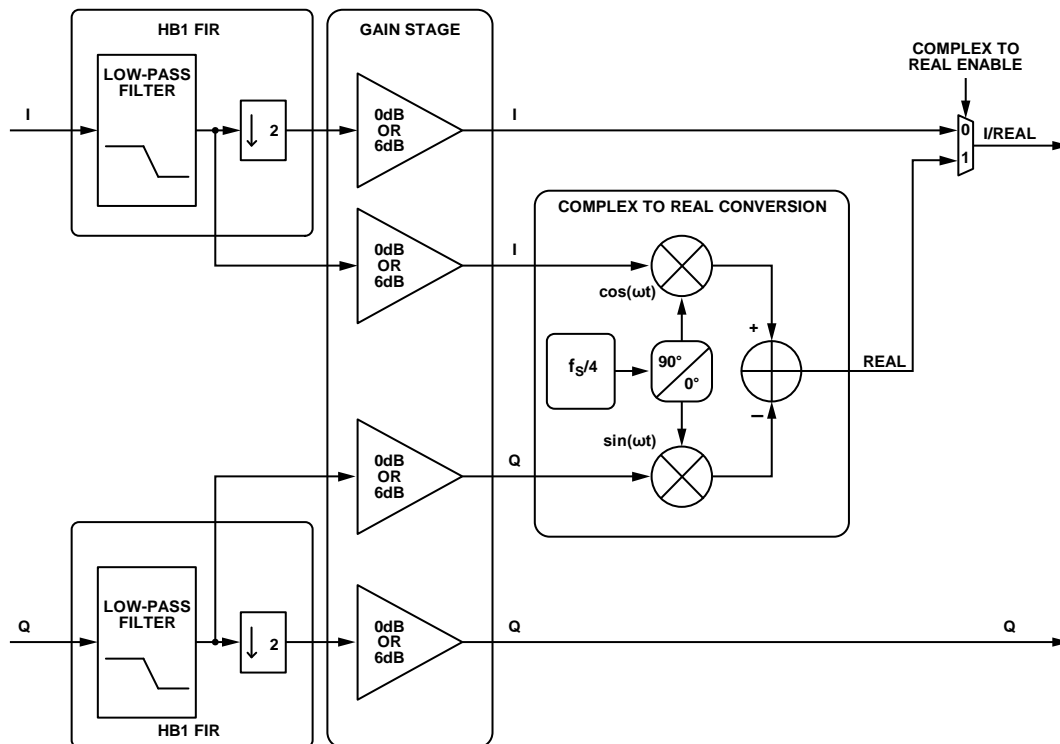

Figure 81. Complex to Real Conversion Block

14894-083

DDC EXAMPLE CONFIGURATIONS

Table 22 describes the register settings for multiple DDC example configurations.

Table 22. DDC Example Configurations (Per ADC Channel Pair)

Chip Application Layer	Chip Decimation Ratio	DDC Input Type	DDC Output Type	Bandwidth Per DDC ¹	No. of Virtual Converters Required	Register Settings ²
One DDC	2	Complex	Complex	$40\% \times f_s$	2	<p>0x0009 = 0x01, 0x02, or 0x03 (pair selection)</p> <p>0x0200 = 0x01 (one DDC; I/Q selected)</p> <p>0x0201 = 0x01 (chip decimate by 2)</p> <p>0x0310 = 0x83 (complex mixer; 0 dB gain; variable IF; complex outputs; HB1 filter)</p> <p>0x0311 = 0x04 (DDC I input = ADC Channel A/ Channel C; DDC Q input = ADC Channel B/ Channel D)</p> <p>0x0314, 0x0315, 0x0316, 0x0317, 0x0318, 0x031A, 0x031D, 0x031E, 0x031F, 0x0320, 0x0321, 0x0322 = FTW and POW set as required by application for DDC 0</p>
One DDC	4	Complex	Complex	$20\% \times f_s$	2	<p>0x0009 = 0x01, 0x02, or 0x03 (pair selection)</p> <p>0x0200 = 0x01 (one DDC; I/Q selected)</p> <p>0x0201 = 0x02 (chip decimate by 4)</p> <p>0x0310 = 0x80 (complex mixer; 0 dB gain; variable IF; complex outputs; HB2 + HB1 filters)</p> <p>0x0311 = 0x04 (DDC I input = ADC Channel A/ Channel C; DDC Q input = ADC Channel B/ Channel D)</p> <p>0x0314, 0x0315, 0x0316, 0x0317, 0x0318, 0x031A, 0x031D, 0x031E, 0x031F, 0x0320, 0x0321, 0x0322 = FTW and POW set as required by application for DDC 0</p>
Two DDCs	2	Real	Real	$20\% \times f_s$	2	<p>0x0009 = 0x01, 0x02, or 0x03 (pair selection)</p> <p>0x0200 = 0x22 (two DDCs; I only selected)</p> <p>0x0201 = 0x01 (chip decimate by 2)</p> <p>0x0310, 0x0330 = 0x48 (real mixer; 6 dB gain; variable IF; real output; HB2 + HB1 filters)</p> <p>0x0311 = 0x00 (DDC 0 I input = ADC Channel A/ Channel C; DDC 0 Q input = ADC Channel A/ Channel C)</p> <p>0x0331 = 0x05 (DDC 1 I input = ADC Channel B/ Channel D; DDC 1 Q input = ADC Channel B/ Channel D)</p> <p>0x0314, 0x0315, 0x0316, 0x0317, 0x0318, 0x031A, 0x031D, 0x031E, 0x031F, 0x0320, 0x0321, 0x0322 = FTW and POW set as required by application for DDC 0</p> <p>0x0334, 0x0335, 0x0336, 0x0337, 0x0338, 0x033A, 0x033D, 0x033E, 0x033F, 0x0340, 0x0341, 0x0342 = FTW and POW set as required by application for DDC 1</p>

Chip Application Layer	Chip Decimation Ratio	DDC Input Type	DDC Output Type	Bandwidth Per DDC ¹	No. of Virtual Converters Required	Register Settings ²
Two DDCs	2	Complex	Complex	$40\% \times f_s$	4	<p>0x0009 = 0x01, 0x02, or 0x03 (pair selection) 0x0200 = 0x22 (two DDCs; I only selected) 0x0201 = 0x01 (chip decimate by 2) 0x0310, 0x0330 = 0x4B (complex mixer; 6 dB gain; variable IF; complex output; HB1 filter) 0x0311, 0x0331 = 0x04 (DDC 0 I input = ADC Channel A/Channel C; DDC 0 Q input = ADC Channel B/Channel D) 0x0314, 0x0315, 0x0316, 0x0317, 0x0318, 0x031A, 0x031D, 0x031E, 0x031F, 0x0320, 0x0321, 0x0322 = FTW and POW set as required by application for DDC 0 0x0334, 0x0335, 0x0336, 0x0337, 0x0338, 0x033A, 0x033D, 0x033E, 0x033F, 0x0340, 0x0341, 0x0342 = FTW and POW set as required by application for DDC 1</p>
Two DDCs	4	Complex	Complex	$20\% \times f_s$	4	<p>0x0009 = 0x01, 0x02, or 0x03 (pair selection) 0x0200 = 0x02 (two DDCs; I/Q selected) 0x0201 = 0x02 (chip decimate by 4) 0x0310, 0x0330 = 0x80 (complex mixer; 0 dB gain; variable IF; complex outputs; HB2 + HB1 filters) 0x0311, 0x0331 = 0x04 (DDC I input = ADC Channel A/Channel C; DDC Q input = ADC Channel B/Channel D) 0x0314, 0x0315, 0x0316, 0x0317, 0x0318, 0x031A, 0x031D, 0x031E, 0x031F, 0x0320, 0x0321, 0x0322 = FTW and POW set as required by application for DDC 0 0x0334, 0x0335, 0x0336, 0x0337, 0x0338, 0x033A, 0x033D, 0x033E, 0x033F, 0x0340, 0x0341, 0x0342 = FTW and POW set as required by application for DDC 1</p>
Two DDCs	4	Complex	Real	$10\% \times f_s$	2	<p>0x0009 = 0x01, 0x02, or 0x03 (pair selection) 0x0200 = 0x22 (two DDCs; I only selected) 0x0201 = 0x02 (chip decimate by 4) 0x0310, 0x0330 = 0x89 (complex mixer; 0 dB gain; variable IF; real output; HB3 + HB2 + HB1 filters) 0x0311, 0x0331 = 0x04 (DDC I input = ADC Channel A/Channel C; DDC Q input = ADC Channel B/Channel D) 0x0314, 0x0315, 0x0316, 0x0317, 0x0318, 0x031A, 0x031D, 0x031E, 0x031F, 0x0320, 0x0321, 0x0322 = FTW and POW set as required by application for DDC 0 0x0334, 0x0335, 0x0336, 0x0337, 0x0338, 0x033A, 0x033D, 0x033E, 0x033F, 0x0340, 0x0341, 0x0342 = FTW and POW set as required by application for DDC 1</p>

Chip Application Layer	Chip Decimation Ratio	DDC Input Type	DDC Output Type	Bandwidth Per DDC ¹	No. of Virtual Converters Required	Register Settings ²
Two DDCs	4	Real	Real	$10\% \times f_s$	2	<p>0x0009 = 0x01, 0x02, or 0x03 (pair selection)</p> <p>0x0200 = 0x22 (two DDCs; I only selected)</p> <p>0x0201 = 0x02 (chip decimate by 4)</p> <p>0x0310, 0x0330 = 0x49 (real mixer; 6 dB gain; variable IF; real output; HB3 + HB2 + HB1 filters)</p> <p>0x0311 = 0x00 (DDC 0 I input = ADC Channel A/ Channel C; DDC 0 Q input = ADC Channel A/ Channel C)</p> <p>0x0331 = 0x05 (DDC 1 I input = ADC Channel B/ Channel D; DDC 1 Q input = ADC Channel B/ Channel D)</p> <p>0x0314, 0x0315, 0x0316, 0x0317, 0x0318, 0x031A, 0x031D, 0x031E, 0x031F, 0x0320, 0x0321, 0x0322 = FTW and POW set as required by application for DDC 0</p> <p>0x0334, 0x0335, 0x0336, 0x0337, 0x0338, 0x033A, 0x033D, 0x033E, 0x033F, 0x0340, 0x0341, 0x0342 = FTW and POW set as required by application for DDC 1</p>
Two DDCs	4	Real	Complex	$20\% \times f_s$	4	<p>0x0009 = 0x01, 0x02, or 0x03 (pair selection)</p> <p>0x0200 = 0x02 (two DDCs; I/Q selected)</p> <p>0x0201 = 0x02 (chip decimate by 4)</p> <p>0x0310, 0x0330 = 0x40 (real mixer; 6 dB gain; variable IF; complex output; HB2 + HB1 filters)</p> <p>0x0311 = 0x00 (DDC 0 I input = ADC Channel A/ Channel C; DDC 0 Q input = ADC Channel A/ Channel C)</p> <p>0x0331 = 0x05 (DDC 1 I input = ADC Channel B/ Channel D; DDC 1 Q input = ADC Channel B/ Channel D)</p> <p>0x0314, 0x0315, 0x0316, 0x0317, 0x0318, 0x031A, 0x031D, 0x031E, 0x031F, 0x0320, 0x0321, 0x0322 = FTW and POW set as required by application for DDC 0</p> <p>0x0334, 0x0335, 0x0336, 0x0337, 0x0338, 0x033A, 0x033D, 0x033E, 0x033F, 0x0340, 0x0341, 0x0342 = FTW and POW set as required by application for DDC 1</p>

Chip Application Layer	Chip Decimation Ratio	DDC Input Type	DDC Output Type	Bandwidth Per DDC ¹	No. of Virtual Converters Required	Register Settings ²
Two DDCs	8	Real	Real	$5\% \times f_s$	2	0x0009 = 0x01, 0x02, or 0x03 (pair selection) 0x0200 = 0x22 (two DDCs; I only selected) 0x0201 = 0x03 (chip decimate by 8) 0x0310, 0x0330 = 0x4A (real mixer; 6 dB gain; variable IF; real output; HB4 + HB3 + HB2 + HB1 filters) 0x0311 = 0x00 (DDC 0 I input = ADC Channel A/ Channel C; DDC 0 Q input = ADC Channel A/ Channel C) 0x0331 = 0x05 (DDC 1 I input = ADC Channel B/ Channel D; DDC 1 Q input = ADC Channel B/ Channel D) 0x0314, 0x0315, 0x0316, 0x0317, 0x0318, 0x031A, 0x031D, 0x031E, 0x031F, 0x0320, 0x0321, 0x0322 = FTW and POW set as required by application for DDC 0 0x0334, 0x0335, 0x0336, 0x0337, 0x0338, 0x033A, 0x033D, 0x033E, 0x033F, 0x0340, 0x0341, 0x0342 = FTW and POW set as required by application for DDC 1

¹ f_s is the ADC sample rate. Bandwidths listed are < -0.001 dB of pass-band ripple and > 100 dB of stop-band alias rejection.

² The NCOs must be synchronized either through the SPI or through the SYSREF \pm pin after all writes to the FTW or POW registers have completed. This is necessary to ensure the proper operation of the NCO. See the NCO Synchronization section for more information.

NOISE SHAPING REQUANTIZER (NSR)

When operating the AD6684 with the NSR enabled, a decimating half-band filter that is optimized at certain input frequency bands can also be enabled. This filter offers the user the flexibility in signal bandwidth processing and image rejection. Careful frequency planning can offer advantages in analog filtering preceding the ADC. The filter can function either in high-pass or low-pass mode. The filter can be optionally enabled on the AD6684 when the NSR is enabled. When operating with the NSR enabled, the decimating half-band filter mode (low pass or high pass) is selected by setting Bit 7 in Register 0x041E. When the decimating half-band filter is enabled, the chip decimation ratio register (Register 0x0201) must be set to a decimation rate of 2 (register value = 0x01).

DECIMATING HALF-BAND FILTER

The AD6684 optional decimating half-band filter reduces the input sample rate by a factor of 2 while rejecting aliases that fall into the band of interest. For an input sample clock of 500 MHz, this filter reduces the output sample rate to 250 MSPS. This filter is designed to provide >40 dB of alias protection for 39.5% of the output sample rate (79% of the Nyquist band). For an ADC sample rate of 500 MSPS, the filter provides a maximum usable bandwidth of 98.75 MHz.

Half-Band Filter Coefficients

The 19-tap, symmetrical, fixed coefficient half-band filter has low power consumption due to its polyphase implementation. Table 23 lists the coefficients of the half-band filter in low-pass mode. In high-pass mode, Coefficient C9 is multiplied by -1. The decimal coefficients used in the implementation and the decimal equivalent values of the coefficients are listed. Coefficients not listed in Table 23 are 0s.

Table 23. Fixed Coefficients for Half-Band Filter

Coefficient Number	Decimal Coefficient	Quantized Coefficient (12-Bit)
0	0.012207	25
C2, C16	-0.022949	-47
C4, C14	0.045410	93
C6, C12	-0.094726	-194
C8, C10	0.314453	644
C9	0.500000	1024

Half-Band Filter Features

The half-band decimating filter provides approximately 39.5% of the output sample rate in usable bandwidth (19.75% of the input sample clock). The filter provides >40 dB of rejection. The normalized response of the half-band filter in low-pass mode is shown in Figure 82. In low-pass mode, operation is allowed in the first Nyquist zone, which includes frequencies of up to $f_s/2$, where f_s is the decimated sample rate. For example, with an input clock of 500 MHz, the output sample rate is 250 MSPS and $f_s/2 = 125$ MHz.

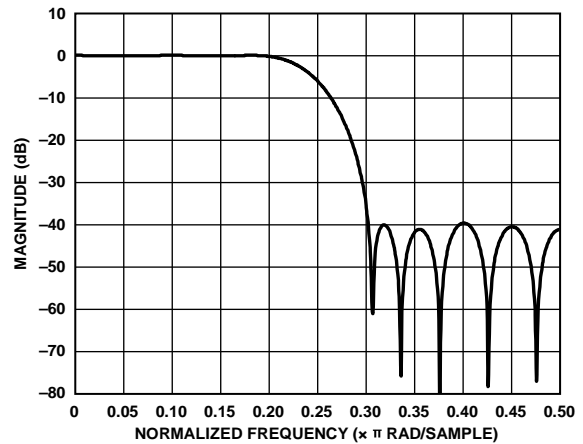

Figure 82. Low-Pass, Half-Band Filter Response

The half-band filter can also be used in high-pass mode. The usable bandwidth remains at 39.5% of the output sample rate (19.75% of the input sample clock), which is the same as in low-pass mode). Figure 83 shows the normalized response of the half-band filter in high-pass mode. In high-pass mode, operation is allowed in the second and third Nyquist zones, which includes frequencies from $f_s/2$ to $3f_s/2$, where f_s is the decimated sample rate. For example, with an input clock of 500 MHz, the output sample rate is 250 MSPS, $f_s/2 = 125$ MHz, and $3f_s/2 = 375$ MHz.

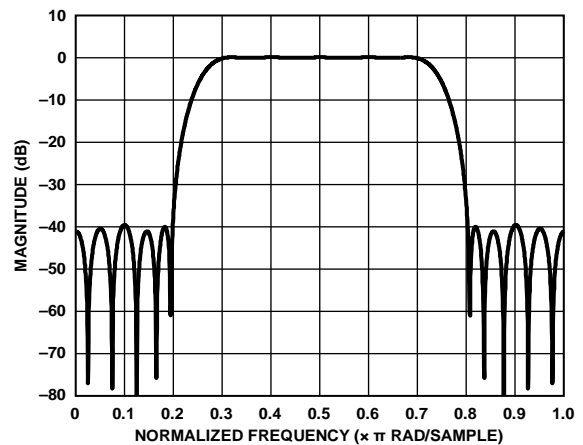

Figure 83. High-Pass, Half-Band Filter Response

NSR OVERVIEW

The AD6684 features an NSR to allow higher than 9-bit SNR to be maintained in a subset of the Nyquist band. The harmonic performance of the receiver is unaffected by the NSR feature. When enabled, the NSR contributes an additional 3.0 dB of loss to the input signal, such that a 0 dBFS input is reduced to -3.0 dBFS at the output pins. This loss does not degrade the SNR performance of the AD6684.

The NSR feature can be independently controlled per channel via the SPI.

Two different bandwidth modes are provided; select the mode from the SPI port. In each of the two modes, the center frequency of the band can be tuned such that IFs can be placed anywhere in the Nyquist band. The NSR feature is enabled by default on the AD6684. The bandwidth and mode of the NSR operation are selected by setting the appropriate bits in Register 0x0420 and Register 0x0422. By selecting the appropriate profile and mode bits in these two registers, the NSR feature can be enabled for the desired mode of operation.

21% BW Mode (>100 MHz at 491.52 MSPS)

The first NSR mode offers excellent noise performance across a bandwidth that is 21% of the ADC output sample rate (42% of the Nyquist band) and can be centered by setting the NSR mode bits in the NSR mode register (Address 0x0420) to 000. In this

mode, the useful frequency range can be set using the 6-bit tuning word in the NSR tuning register (Address 0x0422). There are 59 possible tuning words (TW), from 0 to 58; each step is 0.5% of the ADC sample rate. The following three equations describe the left band edge (f_0), the channel center (f_{CENTER}), and the right band edge (f_i), respectively:

$$f_0 = f_{ADC} \times 0.005 \times TW$$

$$f_{CENTER} = f_0 + 0.105 \times f_{ADC}$$

$$f_i = f_0 + 0.21 \times f_{ADC}$$

28% BW Mode (>130 MHz at 491.52 MSPS)

The second NSR mode offers excellent noise performance across a bandwidth that is 28% of the ADC output sample rate (56% of the Nyquist band) and can be centered by setting the NSR mode bits in the NSR mode register (Address 0x0420) to 001. In this mode, the useful frequency range can be set using the 6-bit tuning word in the NSR tuning register (Address 0x0422). There are 44 possible tuning words (TW, from 0 to 43); each step is 0.5% of the ADC sample rate. The following three equations describe the left band edge (f_0), the channel center (f_{CENTER}), and the right band edge (f_i), respectively:

$$f_0 = f_{ADC} \times 0.005 \times TW$$

$$f_{CENTER} = f_0 + 0.14 \times f_{ADC}$$

$$f_i = f_0 + 0.28 \times f_{ADC}$$

VARIABLE DYNAMIC RANGE (VDR)

The AD6684 features a VDR digital processing block to allow up to a 14-bit dynamic range to be maintained in a subset of the Nyquist band. Across the full Nyquist band, a minimum 9-bit dynamic range is available at all times. This operation is suitable for applications such as DPD processing. The harmonic performance of the receiver is unaffected by this feature. When enabled, VDR does not contribute loss to the input signal but operates by effectively changing the output resolution at the output pins. This feature can be independently controlled per channel via the SPI.

The VDR block operates in either complex or real mode. In complex mode, VDR has selectable bandwidths of 25% and 43% of the output sample rate. In real mode, the bandwidth of operation is limited to 25% of the output sample rate. The bandwidth and mode of the VDR operation are selected by setting the appropriate bits in Register 0x0430.

When the VDR block is enabled, input signals that violate a defined mask (signified by the gray shaded areas in Figure 84) result in the reduction of the output resolution of the AD6684. The VDR block analyzes the peak value of the aggregate signal level in the disallowed zones to determine the reduction of the output resolution. To indicate that the AD6684 is reducing output, the resolution VDR punish bits and/or a VDR high/low resolution bit can optionally be inserted into the output data stream as control bits by programming the appropriate value into Register 0x0559 and Register 0x055A. Up to two control bits can be used without the need to change the converter resolution parameter, N. Up to three control bits can be used, but if using three, the converter resolution parameter, N, must be changed to 13. The VDR high/low resolution bit can be programmed into either of the three available control bits and indicates if VDR is reducing output resolution (bit value is a 1), or if full resolution is available (bit value is a 0). Enable the two punish bits to provide a clearer indication of the available resolution of the sample. To decode these two bits, see Table 24.

Table 24. VDR Reduced Output Resolution Values

VDR Punish Bits[1:0]	Output Resolution (Bits)
00	14
01	13
10	12 or 11
11	10 or 9

The frequency zones of the mask are defined by the bandwidth mode selected in Register 0x0430. The upper amplitude limit for input signals located in these frequency zones is -30 dBFS. If the input signal level in the disallowed frequency zones exceeds an amplitude level of -30 dBFS (into the gray shaded areas), the VDR block triggers a reduction in the output resolution, as shown in Figure 84. The VDR block engages and begins limiting output resolution gradually as the signal amplitudes increase in the mask regions. As the signal amplitude level increases into the mask regions, the output resolution is gradually lowered. For every 6 dB increase in signal level above -30 dBFS, one bit of output resolution is discarded from the output data by the VDR block, as shown in Table 25. These zones can be tuned within the Nyquist band by setting Bits[3:0] in Register 0x0434 to determine the VDR center frequency (f_{VDR}). The VDR center frequency in complex mode can be adjusted from $1/16 f_s$ to $15/16 f_s$ in $1/16 f_s$ steps. In real mode, f_{VDR} can be adjusted from $1/8 f_s$ to $3/8 f_s$ in $1/16 f_s$ steps.

Table 25. VDR Reduced Output Resolution Values

Signal Amplitude Violating Defined VDR Mask	Output Resolution (Bits)
Amplitude ≤ -30 dBFS	14
-30 dBFS $<$ amplitude ≤ -24 dBFS	13
-24 dBFS $<$ amplitude ≤ -18 dBFS	12
-18 dBFS $<$ amplitude ≤ -12 dBFS	11
-12 dBFS $<$ amplitude ≤ -6 dBFS	10
-6 dBFS $<$ amplitude ≤ 0 dBFS	9

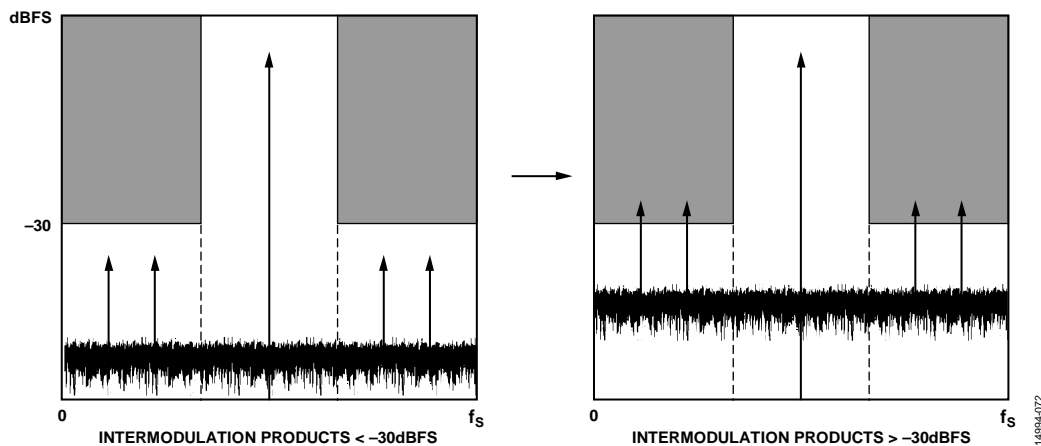

Figure 84. VDR Operation—Reduction in Output Resolution

VDR REAL MODE

The real mode of VDR works over a bandwidth of 25% of the sample rate (50% of the Nyquist band). The output bandwidth of the AD6684 can be 25% only when operating in real mode. Figure 85 shows the frequency zones for the 25% bandwidth real output VDR mode tuned to a center frequency (f_{VDR}) of $f_s/4$ (tuning word = 0x04). The frequency zones where the amplitude cannot exceed -30 dBFS are the upper and lower portions of the Nyquist band signified by the gray shaded areas.

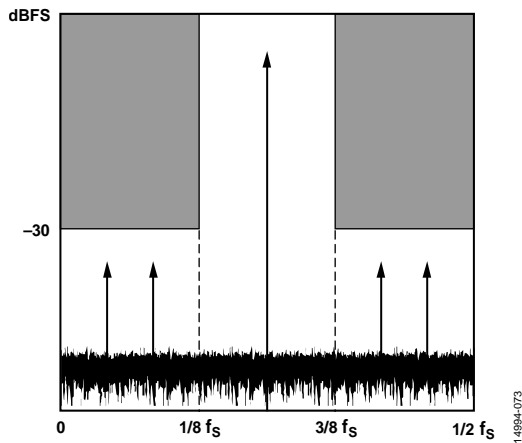

Figure 85. 25% VDR Bandwidth, Real Mode

The center frequency (f_{VDR}) of the VDR function can be tuned within the Nyquist band from $1/8 f_s$ to $3/8 f_s$ in $1/16 f_s$ steps. In real mode, Tuning Word 2 (0x02) through Tuning Word 6 (0x06) are valid. Table 26 shows the relative frequency values, and Table 27 shows the absolute frequency values based on a sample rate of 491.52 MSPS.

Table 26. VDR Tuning Words and Relative Frequency Values, 25% BW, Real Mode

Tuning Word	Lower Band Edge	Center Frequency	Upper Band Edge
2 (0x02)	0	$1/8 f_s$	$1/4 f_s$
3 (0x03)	$1/16 f_s$	$3/16 f_s$	$5/16 f_s$
4 (0x04)	$1/8 f_s$	$1/4 f_s$	$3/8 f_s$
5 (0x05)	$3/16 f_s$	$5/16 f_s$	$7/16 f_s$
6 (0x06)	$1/4 f_s$	$3/8 f_s$	$1/2 f_s$

Table 27. VDR Tuning Words and Absolute Frequency Values, 25% BW, Real Mode ($f_s = 491.52$ MSPS)

Tuning Word	Lower Band Edge (MHz)	Center Frequency (MHz)	Upper Band Edge (MHz)
2 (0x02)	0	61.44	122.88
3 (0x03)	30.72	92.16	153.6
4 (0x04)	61.44	122.88	184.32
5 (0x05)	92.16	153.6	215.04
6 (0x06)	122.88	184.32	245.76

VDR COMPLEX MODE

The complex mode of VDR works with selectable bandwidths of 25% of the sample rate (50% of the Nyquist band) and 43% of the sample rate (86% of the Nyquist band). Figure 86 and Figure 87 show the frequency zones for VDR in the complex mode. When operating VDR in complex mode, place in-phase (I) input signal data in Channel A and place quadrature (Q) signal data in Channel B.

Figure 86 shows the frequency zones for the 25% bandwidth VDR mode with a center frequency of $f_s/4$ (tuning word = 0x04). The frequency zones where the amplitude may not exceed -30 dBFS are the upper and lower portions of the Nyquist band extending into the complex domain.

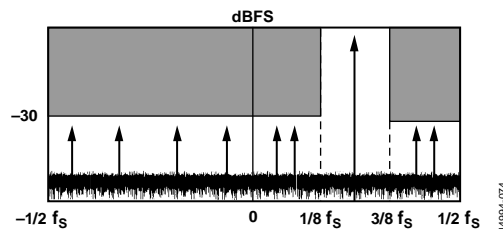

Figure 86. 25% VDR Bandwidth, Complex Mode

The center frequency (f_{VDR}) of the VDR function can be tuned within the Nyquist band from 0 to $15/16 f_s$ in $1/16 f_s$ steps. In complex mode, Tuning Word 0 (0x00) through Tuning Word 15 (0x0F) are valid. Table 28 and Table 29 show the tuning words and frequency values for the 25% complex mode. Table 28 shows the relative frequency values, and Table 29 shows the absolute frequency values based on a sample rate of 491.52 MSPS.

Table 28. VDR Tuning Words and Relative Frequency Values, 25% BW, Complex Mode

Tuning Word	Lower Band Edge	Center Frequency	Upper Band Edge
0 (0x00)	$-1/8 f_s$	0	$1/8 f_s$
1 (0x01)	$-1/16 f_s$	$1/16 f_s$	$3/16 f_s$
2 (0x02)	0	$1/8 f_s$	$1/4 f_s$
3 (0x03)	$1/16 f_s$	$3/16 f_s$	$5/16 f_s$
4 (0x04)	$1/8 f_s$	$1/4 f_s$	$3/8 f_s$
5 (0x05)	$3/16 f_s$	$5/16 f_s$	$7/16 f_s$
6 (0x06)	$1/4 f_s$	$3/8 f_s$	$1/2 f_s$
7 (0x07)	$5/16 f_s$	$7/16 f_s$	$9/16 f_s$
8 (0x08)	$3/8 f_s$	$1/2 f_s$	$5/8 f_s$
9 (0x09)	$7/16 f_s$	$9/16 f_s$	$11/16 f_s$
10 (0x0A)	$1/2 f_s$	$5/8 f_s$	$3/4 f_s$
11 (0x0B)	$9/16 f_s$	$11/16 f_s$	$13/16 f_s$
12 (0x0C)	$5/8 f_s$	$3/4 f_s$	$7/8 f_s$
13 (0x0D)	$11/16 f_s$	$13/16 f_s$	$15/16 f_s$
14 (0x0E)	$3/4 f_s$	$7/8 f_s$	f_s
15 (0x0F)	$13/16 f_s$	$15/16 f_s$	$17/16 f_s$

Table 29. VDR Tuning Words and Absolute Frequency Values, 25% BW, Complex Mode ($f_s = 491.52$ MSPS)

Tuning Word	Lower Band Edge (MHz)	Center Frequency (MHz)	Upper Band Edge (MHz)
0 (0x00)	-61.44	0.00	61.44
1 (0x01)	-30.72	30.72	92.16
2 (0x02)	0.00	61.44	122.88
3 (0x03)	30.72	92.16	153.6
4 (0x04)	61.44	122.88	184.32
5 (0x05)	92.16	153.6	215.04
6 (0x06)	122.88	184.32	245.76
7 (0x07)	153.6	215.04	276.48
8 (0x08)	184.32	245.76	307.2
9 (0x09)	215.04	276.48	337.92
10 (0x0A)	245.76	307.2	368.64
11 (0x0B)	276.48	337.92	399.36
12 (0x0C)	307.2	368.64	430.08
13 (0x0D)	337.92	399.36	460.8
14 (0x0E)	368.64	430.08	491.52
15 (0x0F)	399.36	460.8	522.24

Table 30. VDR Tuning Words and Relative Frequency Values, 43% BW, Complex Mode

Tuning Word	Lower Band Edge (MHz)	Center Frequency (MHz)	Upper Band Edge (MHz)
0 (0x00)	$-14/65 f_s$	0	$14/65 f_s$
1 (0x01)	$-11/72 f_s$	$1/16 f_s$	$5/18 f_s$
2 (0x02)	$-1/11 f_s$	$1/8 f_s$	$16/47 f_s$
3 (0x03)	$-1/36 f_s$	$3/16 f_s$	$29/72 f_s$
4 (0x04)	$1/29 f_s$	$1/4 f_s$	$20/43 f_s$
5 (0x05)	$7/72 f_s$	$5/16 f_s$	$19/36 f_s$
6 (0x06)	$4/25 f_s$	$3/8 f_s$	$49/83 f_s$
7 (0x07)	$2/9 f_s$	$7/16 f_s$	$47/72 f_s$
8 (0x08)	$2/7 f_s$	$1/2 f_s$	$5/7 f_s$
9 (0x09)	$25/72 f_s$	$9/16 f_s$	$7/9 f_s$
10 (0x0A)	$34/83 f_s$	$5/8 f_s$	$21/25 f_s$
11 (0x0B)	$17/36 f_s$	$11/16 f_s$	$65/72 f_s$
12 (0x0C)	$23/43 f_s$	$3/4 f_s$	$28/29 f_s$
13 (0x0D)	$43/72 f_s$	$13/16 f_s$	$37/36 f_s$
14 (0x0E)	$31/47 f_s$	$7/8 f_s$	$12/11 f_s$
15 (0x0F)	$13/18 f_s$	$15/16 f_s$	$83/72 f_s$

Table 30 and Table 31 show the tuning words and frequency values for the 43% complex mode. Table 30 shows the relative frequency values, and Table 31 shows the absolute frequency values based on a sample rate of 491.52 MSPS. Figure 87 shows the frequency zones for the 43% BW VDR mode with a center frequency (f_{VDR}) of $f_s/4$ (tuning word = 0x04). The frequency zones where the amplitude may not exceed -30 dBFS are the upper and lower portions of the Nyquist band extending into the complex domain.

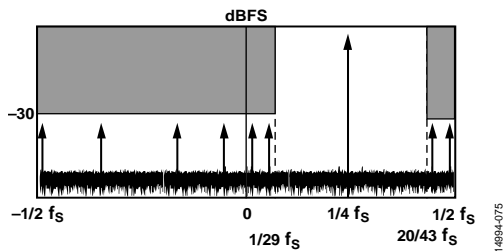

Figure 87. 43% VDR Bandwidth, Complex Mode

Table 31. VDR Tuning Words and Absolute Frequency Values, 43% BW, Complex Mode ($f_s = 491.52$ MSPS)

Tuning Word	Lower Band Edge (MHz)	Center Frequency (MHz)	Upper Band Edge (MHz)
0 (0x00)	-105.37	0.00	105.87
1 (0x01)	-75.09	30.72	136.53
2 (0x02)	-44.68	61.44	167.33
3 (0x03)	-13.65	92.16	197.97
4 (0x04)	16.95	122.88	228.61
5 (0x05)	47.79	153.6	259.41
6 (0x06)	78.64	184.32	290.17
7 (0x07)	109.23	215.04	320.85
8 (0x08)	140.43	245.76	351.09
9 (0x09)	170.67	276.48	382.29
10 (0x0A)	201.35	307.2	412.88
11 (0x0B)	232.11	337.92	443.73
12 (0x0C)	262.91	368.64	474.57
13 (0x0D)	293.55	399.36	505.17
14 (0x0E)	324.19	430.08	536.2
15 (0x0F)	354.99	460.8	566.61

DIGITAL OUTPUTS

INTRODUCTION TO THE JESD204B INTERFACE

The AD6684 digital outputs are designed to the JEDEC standard JESD204B, serial interface for data converters. JESD204B is a protocol to link the AD6684 to a digital processing device over a serial interface with lane rates of up to 15 Gbps. The benefits of the JESD204B interface over LVDS include a reduction in required board area for data interface routing, and an ability to enable smaller packages for converter and logic devices.

JESD204B OVERVIEW

The JESD204B data transmit blocks assemble the parallel data from the ADC into frames and uses 8-bit/10-bit encoding as well as optional scrambling to form serial output data. Lane synchronization is supported through the use of special control characters during the initial establishment of the link. Additional control characters are embedded in the data stream to maintain synchronization thereafter. A JESD204B receiver is required to complete the serial link. For additional details on the JESD204B interface, refer to the JESD204B standard.

The JESD204B data transmit blocks in the AD6684 map up to two physical ADCs or up to four virtual converters (when the DDCs are enabled) over each of the two JESD204B links. Each link can be configured to use one or two JESD204B lanes for up to a total of four lanes for the AD6684 chip. The JESD204B specification refers to a number of parameters to define the link, and these parameters must match between the JESD204B transmitter (the AD6684 output) and the JESD204B receiver (the logic device input). The JESD204B outputs of the AD6684 function effectively as two individual JESD204B links. The two JESD204B links can be synchronized, if desired, using the SYSREF \pm input.

Each JESD204B link is described according to the following parameters:

- L = number of lanes per converter device (lanes per link) (AD6684 value = 1 or 2)
- M = number of converters per converter device (virtual converters per link) (AD6684 value = 1, 2, or 4)
- F = octets per frame (AD6684 value = 1, 2, 4, or 8)
- N' = number of bits per sample (JESD204B word size) (AD6684 value = 8 or 16)
- N = converter resolution (AD6684 value = 7 to 16)
- CS = number of control bits per sample (AD6684 value = 0, 1, 2, or 3)

- K = number of frames per multiframe (AD6684 value = 4, 8, 12, 16, 20, 24, 28, or 32)
- S = samples transmitted per single converter per frame cycle (AD6684 value = set automatically based on L, M, F, and N')
- HD = high density mode (AD6684 = set automatically based on L, M, F, and N')
- CF = number of control words per frame clock cycle per converter device (AD6684 value = 0)

Figure 88 shows a simplified block diagram of the AD6684 JESD204B link. By default, the AD6684 is configured to use four converters and four lanes. The Converter A and Converter B data is output to SERDOUTAB0 \pm and SERDOUTAB1 \pm , and the Converter C and Converter D data is output to SERDOUTCD0 \pm and SERDOUTCD1 \pm . The AD6684 allows other configurations, such as combining the outputs of each pair of converters into a single lane, or changing the mapping of the digital output paths. These modes are set up via a quick configuration register in the SPI register map, along with additional customizable options.

By default in the AD6684, the 14-bit converter word from each converter is broken into two octets (eight bits of data). Bit 13 (MSB) through Bit 6 are in the first octet. The second octet contains Bit 5 through Bit 0 (LSB) and two tail bits. The tail bits can be configured as zeros or a pseudorandom number sequence. The tail bits can also be replaced with control bits indicating overrange, SYSREF \pm , VDR punish bits, or fast detect output. Control bits are filled and inserted MSB first such that enabling CS = 1 activates Control Bit 2, enabling CS = 2 activates Control Bit 2 and Control Bit 1, and enabling CS = 3 activates Control Bit 2, Control Bit 1, and Control Bit 0.

The two resulting octets can be scrambled. Scrambling is optional; however, it is recommended to avoid spectral peaks when transmitting similar digital data patterns. The scrambler uses a self synchronizing, polynomial-based algorithm defined by the equation $1 + x^{14} + x^{15}$. The descrambler in the receiver is a self synchronizing version of the scrambler polynomial.

The two octets are then encoded with an 8-bit/10-bit encoder. The 8-bit/10-bit encoder works by taking eight bits of data (an octet) and encoding them into a 10-bit symbol. Figure 89 shows how the 14-bit data is taken from the ADC, the tail bits are added, the two octets are scrambled, and how the octets are encoded into two 10-bit symbols. Figure 89 shows the default data format.

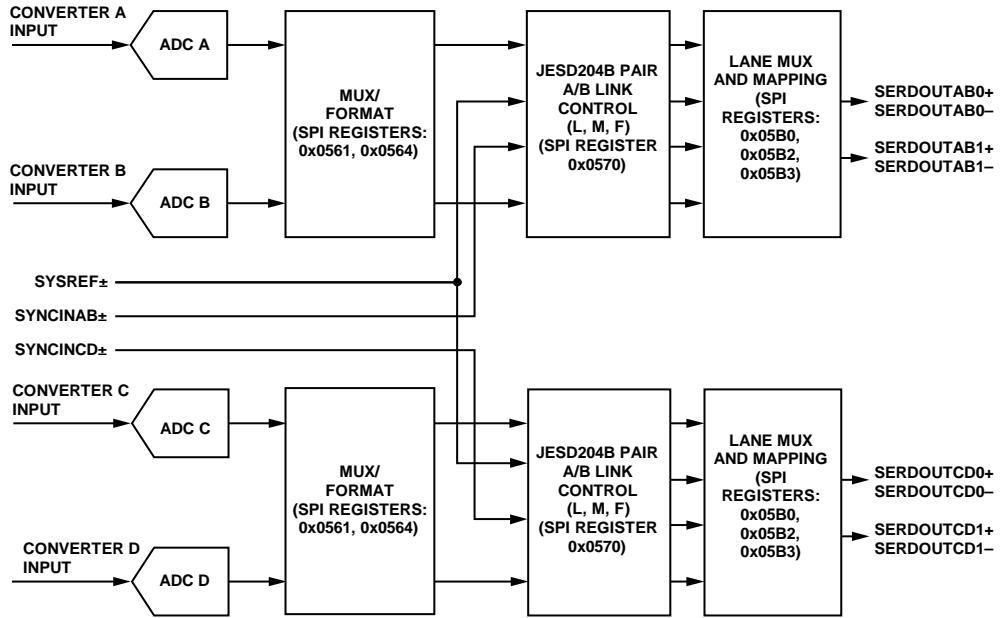

Figure 88. Transmit Link Simplified Block Diagram Showing Full Bandwidth Mode (Register 0x0200 = 0x00)

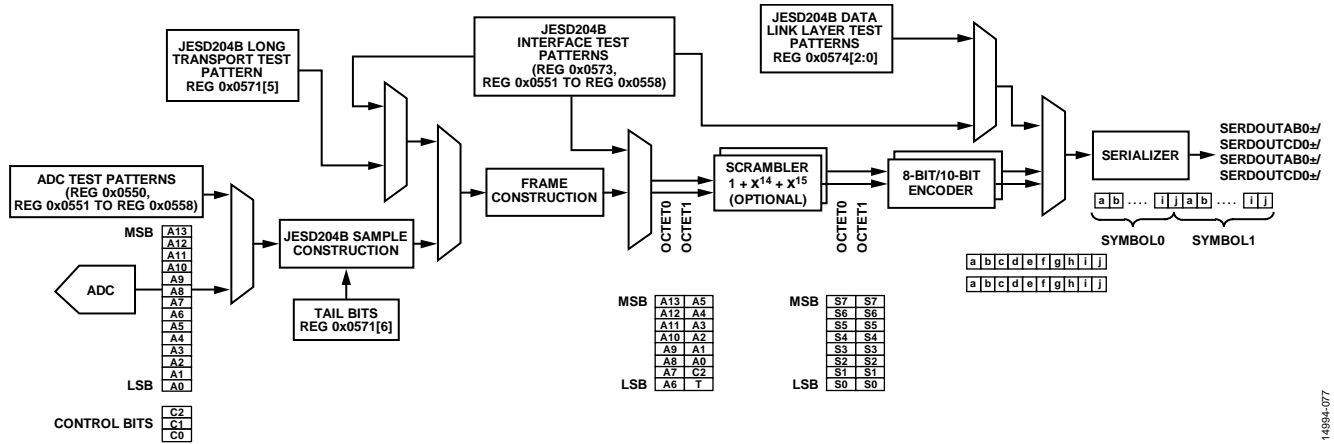

Figure 89. ADC Output Datapath Showing Data Framing

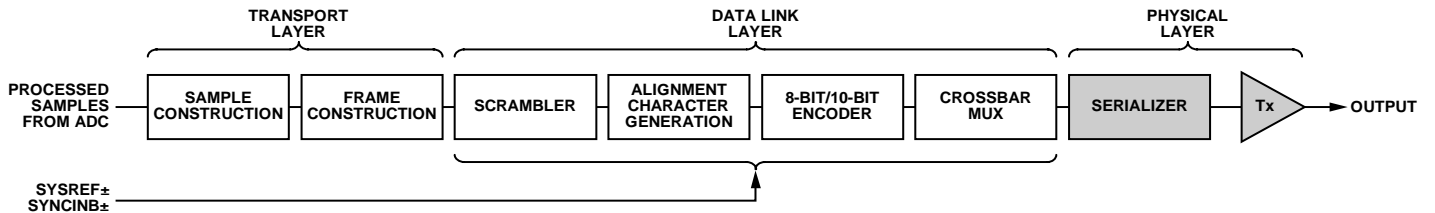

Figure 90. Data Flow

FUNCTIONAL OVERVIEW

The block diagram in Figure 90 shows the flow of data through each of the two JESD204B links from the sample input to the physical output. The processing can be divided into layers that are derived from the open source initiative (OSI) model widely used to describe the abstraction layers of communications systems. These layers are the transport layer, data link layer, and physical layer (serializer and output driver).

Transport Layer

The transport layer handles packing the data (consisting of samples and optional control bits) into JESD204B frames that are mapped to 8-bit octets. These octets are sent to the data link layer. The transport layer mapping is controlled by rules derived from the link parameters. Tail bits are added to fill gaps where required. The following equation can be used to determine the number of tail bits within a sample (JESD204B word):

$$T = N' - N - CS$$

Data Link Layer

The data link layer is responsible for the low level functions of passing data across the link. These functions include optionally scrambling the data, inserting control characters for multichip synchronization, lane alignment, or monitoring, and encoding 8-bit octets into 10-bit symbols. The data link layer is also responsible for sending the initial lane alignment sequence (ILAS), which contains the link configuration data used by the receiver to verify the settings in the transport layer.

Physical Layer

The physical layer consists of the high speed circuitry clocked at the serial clock rate. In this layer, parallel data is converted into one, two, or four lanes of high speed differential serial data.

JESD204B LINK ESTABLISHMENT

The AD6684 JESD204B transmitter (Tx) interface operates in Subclass 1 as defined in the JEDEC Standard 204B (July 2011 specification). The link establishment process is divided into the following steps: code group synchronization and SYNCINB±AB/ SYNCINB±CD, initial lane alignment sequence, and user data and error correction.

Code Group Synchronization (CGS) and SYNCINB±

The CGS is the process by which the JESD204B receiver finds the boundaries between the 10-bit symbols in the stream of data. During the CGS phase, the JESD204B transmit block transmits /K28.5/ characters. The receiver must locate /K28.5/

characters in its input data stream using clock and data recovery (CDR) techniques.

The receiver issues a synchronization request by asserting the SYNCINB±AB and SYNCINB±CD pins of the AD6684 low. The JESD204B Tx then begins sending /K/ characters. After the receiver synchronizes, it waits for the correct reception of at least four consecutive /K/ symbols. It then deasserts SYNCINB±AB and SYNCINB±CD. The AD6684 then transmits an ILAS on the following local multiframe clock (LMFC) boundary.

For more information on the code group synchronization phase, refer to the JEDEC Standard JESD204B, July 2011, Section 5.3.3.1.

The SYNCINB±AB and SYNCINB±CD pin operation can also be controlled by the SPI. The SYNCINB±AB and SYNCINB±CD signals are differential LVDS mode signals by default, but can also be driven single-ended. For more information on configuring the SYNCINB±AB and SYNCINB±CD pin operation, refer to Register 0x0572.

Initial Lane Alignment Sequence (ILAS)

The ILAS phase follows the CGS phase and begins on the next LMFC boundary. The ILAS consists of four multiframe, with an /R/ character marking the beginning and an /A/ character marking the end. The ILAS begins by sending an /R/ character followed by 0 to 255 ramp data for one multiframe. On the second multiframe, the link configuration data is sent, starting with the third character. The second character is a /Q/ character to confirm that the link configuration data follows. All undefined data slots are filled with ramp data. The ILAS sequence is never scrambled.

The ILAS sequence construction is shown in Figure 91. The four multiframe include the following:

- Multiframe 1. Begins with an /R/ character (/K28.0/) and ends with an /A/ character (/K28.3/).
- Multiframe 2. Begins with an /R/ character followed by a /Q/ (/K28.4/) character, followed by link configuration parameters over 14 configuration octets (see Table 32) and ends with an /A/ character. Many of the parameter values are of the value - 1 notation.
- Multiframe 3. Begins with an /R/ character (/K28.0/) and ends with an /A/ character (/K28.3/).
- Multiframe 4. Begins with an /R/ character (/K28.0/) and ends with an /A/ character (/K28.3/).

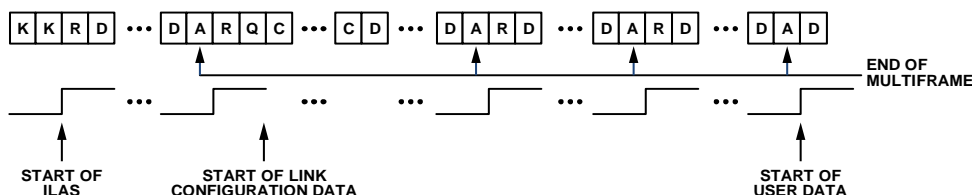

Figure 91. Initial Lane Alignment Sequence

User Data and Error Detection

After the initial lane alignment sequence is complete, the user data is sent. Normally, within a frame, all characters are considered user data. However, to monitor the frame clock and multiframe clock synchronization, there is a mechanism for replacing characters with /F/ or /A/ alignment characters when the data meets certain conditions. These conditions are different for unscrambled and scrambled data. The scrambling operation is enabled by default, but it can be disabled using the SPI.

For scrambled data, any 0xFC character at the end of a frame is replaced with an /F/, and any 0xFD character at the end of a multiframe is replaced with an /A/. The JESD204B receiver (Rx) checks for /F/ and /A/ characters in the received data stream and verifies that they only occur in the expected locations. If an unexpected /F/ or /A/ character is found, the receiver handles the situation by using dynamic realignment or asserting the SYNCINB± signal for more than four frames to initiate a resynchronization. For unscrambled data, if the final character of two subsequent frames are equal, the second character is replaced with an /F/ if it is at the end of a frame, and an /A/ if it is at the end of a multiframe.

Insertion of alignment characters can be modified using the SPI. The frame alignment character insertion (FACI) is enabled by default. More information on the link controls is available in the Memory Map section, Register 0x0571.

8-Bit/10-Bit Encoder

The 8-bit/10-bit encoder converts 8-bit octets into 10-bit symbols and inserts control characters into the stream when needed. The control characters used in JESD204B are shown in Table 32. The 8-bit/10-bit encoding ensures that the signal is dc balanced by using the same number of ones and zeros across multiple symbols.

Table 32. AD6684 Control Characters used in JESD204B

Abbreviation	Control Symbol	8-Bit Value	10-Bit Value, RD ¹ = -1	10-Bit Value, RD ¹ = +1	Description
/R/	/K28.0/	000 11100	001111 0100	110000 1011	Start of multiframe
/A/	/K28.3/	011 11100	001111 0011	110000 1100	Lane alignment
/Q/	/K28.4/	100 11100	001111 0100	110000 1101	Start of link configuration data
/K/	/K28.5/	101 11100	001111 1010	110000 0101	Group synchronization
/F/	/K28.7/	111 11100	001111 1000	110000 0111	Frame alignment

¹ RD means running disparity.

The 8-bit/10-bit interface has options that can be controlled via the SPI. These operations include bypass and invert. These options are intended to be troubleshooting tools for the verification of the digital front end (DFE). Refer to the Memory Map section, Register 0x0572, Bits[2:1] for information on configuring the 8-bit/10-bit encoder.

PHYSICAL LAYER (DRIVER) OUTPUTS

Digital Outputs, Timing, and Controls

The AD6684 physical layer consists of drivers that are defined in the JEDEC Standard JESD204B, July 2011. The differential digital outputs are powered up by default. The drivers use a dynamic 100 Ω internal termination to reduce unwanted reflections.

Place a 100 Ω differential termination resistor at each receiver input to result in a nominal 300 mV p-p swing at the receiver (see Figure 92). Alternatively, single-ended 50 Ω termination can be used. When single-ended termination is used, the termination voltage is DRVDD1/2. Otherwise, 0.1 μF ac coupling capacitors can be used to terminate to any single-ended voltage.

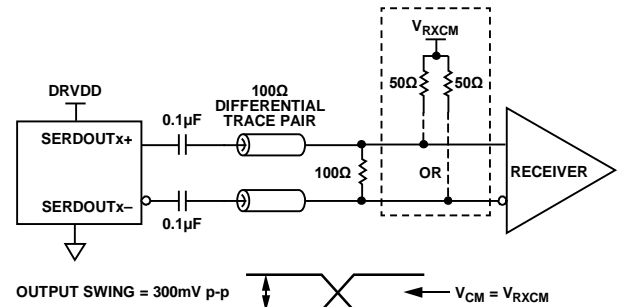

Figure 92. AC-Coupled Digital Output Termination Example

14894-080

The AD6684 digital outputs can interface with custom application specific integrated circuits (ASICs) and field programmable gate array (FPGA) receivers, providing superior switching performance in noisy environments. Single point to point network topologies are recommended with a single differential 100 Ω termination resistor placed as close to the receiver inputs as possible. The common mode of the digital output automatically biases itself to half the DRVDD1 supply of 1.25 V ($V_{CM} = 0.6\text{ V}$). See Figure 93 for an example of dc coupling the outputs to the receiver logic.

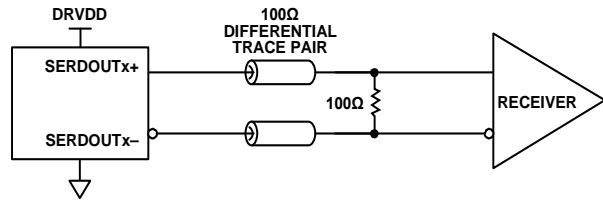

Figure 93. DC-Coupled Digital Output Termination Example

If there is no far end receiver termination, or if there is poor differential trace routing, timing errors may result. To avoid such timing errors, it is recommended that the trace length be less than six inches, and that the differential output traces be close together and at equal lengths.

Figure 95, Figure 96, and Figure 97 show examples of the digital output data eye, time interval error (TIE) jitter histogram, and bathtub curve, respectively, for one AD6684 lane running at 15 Gbps. The format of the output data is twos complement by default. To change the output data format, see the Memory Map section (Register 0x0561 in Table 46).

De-Emphasis

De-emphasis enables the receiver eye diagram mask to be met in conditions where the interconnect insertion loss does not meet the JESD204B specification. Use the pre-emphasis feature only when the receiver is unable to recover the clock due to excessive insertion loss. Under normal conditions, pre-emphasis is disabled to conserve power. Additionally, enabling and setting too high a pre-emphasis value on a short link can cause the receiver eye diagram to fail. Use the pre-emphasis setting with caution because it can increase electromagnetic interference (EMI). See the Memory Map section (Registers 0x05C4 and Register 0x05C6 in Table 46) for more details.

Table 33 shows the insertion loss with respect to the emphasis settings.

Table 33. Insertion Loss Table

Insertion Loss (dB)	Voltage Swing Setting	De-Emphasis Setting	Post Tap Level (dB)
0 to 4	0	0	0
4 to 9	0	1	3
9 to 14	0	2	6
>14	0	3	9

Figure 94 shows deterministic jitter vs. insertion loss.

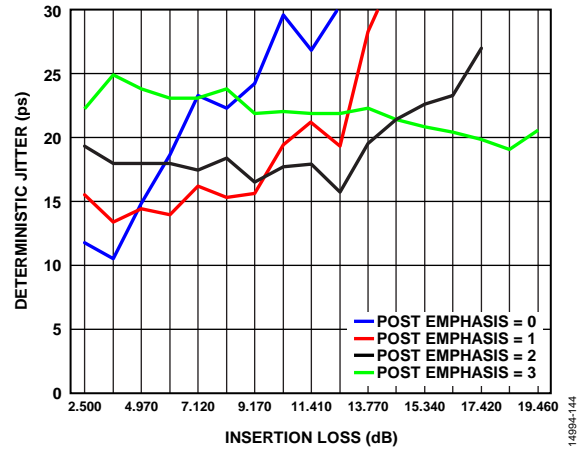

Figure 94. Deterministic Jitter vs. Insertion Loss

Phase-Locked Loop

The phase-locked loop (PLL) is used to generate the serializer clock, which operates at the JESD204B lane rate. The status of the PLL lock can be checked in the PLL lock status bit (Register 0x056F, Bit 7). This read only bit lets the user know if the PLL has achieved a lock for the specific setup. The JESD204B lane rate control bit, Bit 4 of Register 0x056E, must be set to correspond with the lane rate.

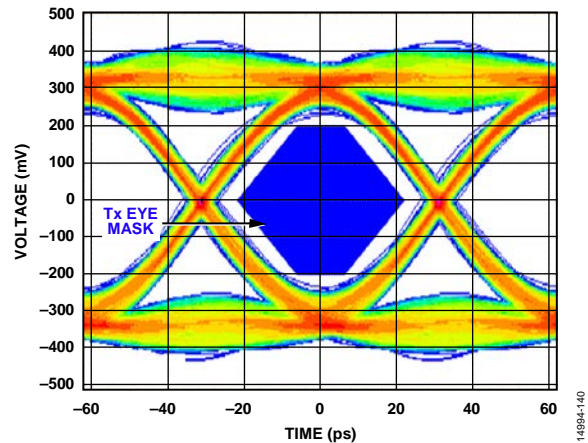

Figure 95. AD6684 Digital Outputs Data Eye Diagram; External 100 Ω Terminations at 15 Gbps

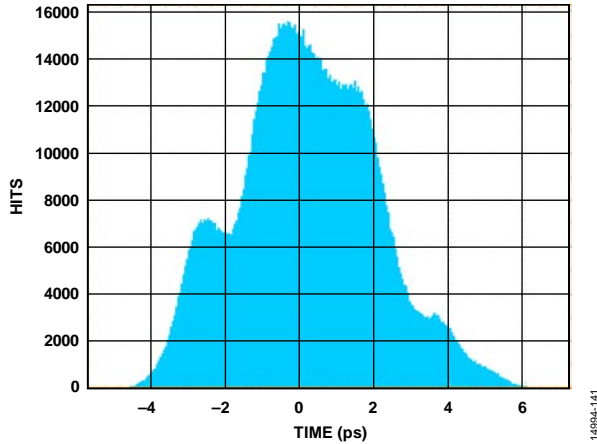

Figure 96. AD6684 Digital Outputs Histogram; External 100 Ω Terminations at 15 Gbps

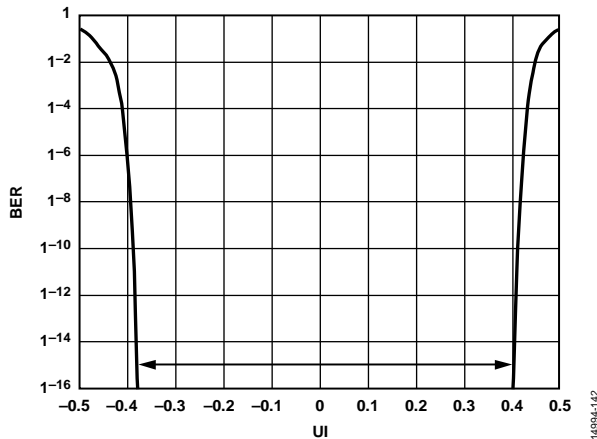

Figure 97. AD6684 Digital Outputs Bathtub Curve; External 100 Ω Terminations at 15 Gbps

JESD204B Tx CONVERTER MAPPING

To support the different chip operating modes, the AD6684 design treats each sample stream (real or I/Q) as originating from separate virtual converters. The I/Q samples are always mapped in pairs with the I samples mapped to the first virtual converter and the Q samples mapped to the second virtual converter. With this transport layer mapping, the number of virtual converters are the same whether

- A single real converter is used along with a digital downconverter block producing I/Q outputs, or
- An analog downconversion is used with two real converters producing I/Q outputs.

Figure 98 shows a block diagram of the two scenarios described for I/Q transport layer mapping.

The JESD204B Tx block for AD6684 supports up to four DDC blocks. Each DDC block outputs either two sample streams (I/Q) for the complex data components (real + imaginary), or one sample stream for real (I) data. The JESD204B interface can be configured to use up to eight virtual converters depending on the DDC configuration. Figure 99 shows the virtual converters and their relationship to the DDC outputs when complex outputs are used. Table 34 shows the virtual converter mapping for each chip operating mode when channel swapping is disabled.

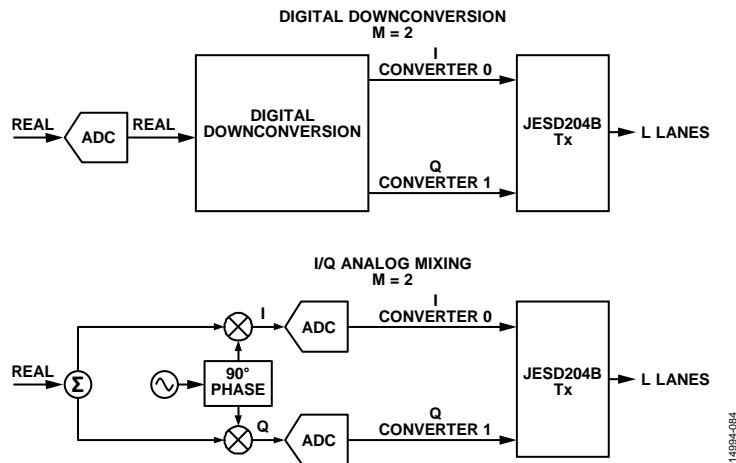

Figure 98. I/Q Transport Layer Mapping

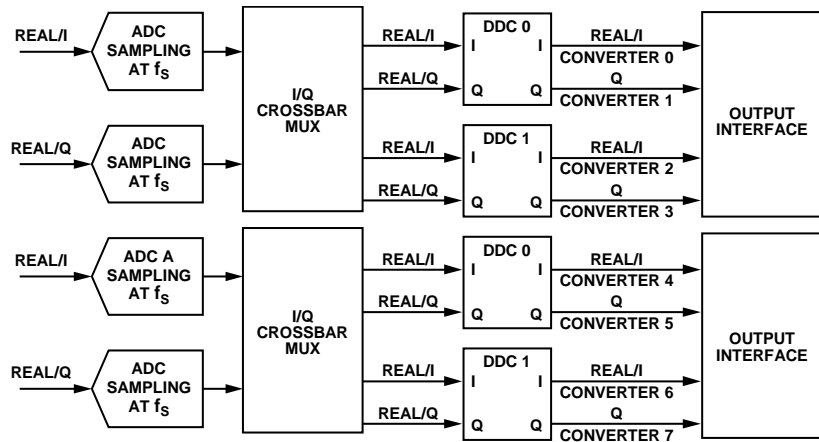

Figure 99. DDCs and Virtual Converter Mapping

SETTING UP THE AD6684 DIGITAL INTERFACE

The following SPI writes are required for the AD6684 at startup and each time the ADC is reset (datapath reset, soft reset, link power-down/power-up, or hard reset):

1. Write 0x4F to Register 0x1228.
2. Write 0x0F to Register 0x1228.
3. Write 0x04 to Register 0x1222.
4. Write 0x00 to Register 0x1222.
5. Write 0x08 to Register 0x1262.
6. Write 0x00 to Register 0x1262.

The AD6684 has two JESD204B links. The device offers an easy way to set up the JESD204B link through the JESD204B quick configuration register (Register 0x0570). The serial outputs (SERDOUTABx± and SERDOUTCDx±) are considered to be part of one JESD204B link. The basic parameters that determine the link setup are

- Number of lanes per link (L)
- Number of converters per link (M)
- Number of octets per frame (F)

If the internal DDCs are used for on-chip digital processing, M represents the number of virtual converters. The virtual converter mapping setup is shown in Figure 99.

The maximum lane rate allowed by the JESD204B specification is 15 Gbps. The lane line rate is related to the JESD204B parameters using the following equation:

$$\text{Lane Line Rate} = \frac{M \times N' \times \left(\frac{10}{8}\right) \times f_{OUT}}{L}$$

where:

$$f_{OUT} = \frac{f_{ADC_CLOCK}}{\text{Decimation Ratio}}$$

The decimation ratio (DCM) is the parameter programmed in Register 0x0201.

Use the following steps to configure the output:

1. Power down the link.
2. Select quick configuration options.
3. Configure detailed options
4. Set output lane mapping (optional).
5. Set additional driver configuration options (optional).
6. Power up the link.

If the lane line rate calculated is less than 6.75 Gbps, select the low line rate option by programming a value of 0x10 to Register 0x056E.

Table 35 and Table 36 show the JESD204B output configurations for both $N' = 16$ and $N' = 8$ for a given number of virtual converters. Take care to ensure that the serial line rate for given configuration is within the supported range of 1.6875 Gbps to 15 Gbps.

Table 34. Virtual Converter Mapping (Per Link)

Number of Virtual Converters Supported	Chip Application Mode (Register 0x0200, Bits[3:0])	Chip Q Ignore (Register 0x0200, Bit 5)	Virtual Converter Mapping			
			0	1	2	3
1 to 2	Full bandwidth mode (0x0)	Real or complex (0x0)	ADC A/C samples	ADC B/D samples	Unused	Unused
1	One DDC mode (0x1)	Real (I only) (0x1)	DDC 0 I samples	Unused	Unused	Unused
2	One DDC mode (0x1)	Complex (I/Q) (0x0)	DDC 0 I samples	DDC 0 Q samples	Unused	Unused
2	Two DDC mode (0x2)	Real (I only) (0x1)	DDC 0 I samples	DDC 1 I samples	Unused	Unused
4	Two DDC mode (0x2)	Complex (I/Q) (0x0)	DDC 0 I samples	DDC 0 Q samples	DDC 1 I samples	DDC 1 Q samples

Table 35. JESD204B Output Configurations for N' = 16

Number of Virtual Converters Supported (Same Value as M)	JESD204B Quick Configuration (Register 0x0570)	JESD204B Serial Line Rate ¹	JESD204B Transport Layer Settings ²								
			L	M	F	S	HD	N	N'	CS	K ³
1	0x01	20 × f _{OUT}	1	1	2	1	0	8 to 16	16	0 to 3	Only valid K values that are divisible by 4 are supported
	0x40	10 × f _{OUT}	2	1	1	1	1	8 to 16	16	0 to 3	
	0x41	10 × f _{OUT}	2	1	2	2	0	8 to 16	16	0 to 3	
2	0x0A	40 × f _{OUT}	1	2	4	1	0	8 to 16	16	0 to 3	
	0x49	20 × f _{OUT}	2	2	2	1	0	8 to 16	16	0 to 3	
4	0x13	80 × f _{OUT}	1	4	8	1	0	8 to 16	16	0 to 3	
	0x52	40 × f _{OUT}	2	4	4	1	0	8 to 16	16	0 to 3	

¹ f_{OUT} = output sample rate = ADC sample rate/chip decimation ratio. The JESD204B serial line rate must be ≥1687.5 Mbps and ≤15,000 Mbps. When the serial line rate is ≤15 Gbps and >13.5 Gbps, set Bits[7:4] to 0x3 in Register 0x056E. When the serial line rate is ≤13.5 Gbps and >6.75 Gbps, set Bits[7:4] to 0x0 in Register 0x056E. When the serial line rate is ≤6.75 Gbps and >3.375 Gbps, set Bits[7:4] to 0x1 in Register 0x056E. When the serial line rate is ≤3.375 Gbps and ≥1687.5 Mbps, set Bits[7:4] to 0x5 in Register 0x056E.

² JESD204B transport layer descriptions are as described in the JESD204B Overview section.

³ For F = 1, K = 20, 24, 28, and 32. For F = 2, K = 12, 16, 20, 24, 28, and 32. For F = 4, K = 8, 12, 16, 20, 24, 28, and 32. For F = 8 and F = 16, K = 4, 8, 12, 16, 20, 24, 28, and 32.

Table 36. JESD204B Output Configurations for N' = 8

Number of Virtual Converters Supported (Same Value as M)	JESD204B Quick Configuration (Register 0x0570)	Serial Line Rate ¹	JESD204B Transport Layer Settings ²								
			L	M	F	S	HD	N	N'	CS	K ³
1	0x00	10 × f _{OUT}	1	1	1	1	0	7 to 8	8	0 to 1	Only valid K values which are divisible by 4 are supported
	0x01	10 × f _{OUT}	1	1	2	2	0	7 to 8	8	0 to 1	
	0x40	5 × f _{OUT}	2	1	1	2	0	7 to 8	8	0 to 1	
	0x41	5 × f _{OUT}	2	1	2	4	0	7 to 8	8	0 to 1	
	0x42	5 × f _{OUT}	2	1	4	8	0	7 to 8	8	0 to 1	
2	0x09	20 × f _{OUT}	1	2	2	1	0	7 to 8	8	0 to 1	
	0x48	10 × f _{OUT}	2	2	1	1	0	7 to 8	8	0 to 1	
	0x49	10 × f _{OUT}	2	2	2	2	0	7 to 8	8	0 to 1	

¹ f_{OUT} = output sample rate = ADC sample rate/chip decimation ratio. The JESD204B serial line rate must be ≥1687.5 Mbps and ≤15,000 Mbps. When the serial line rate is ≤15 Gbps and >13.5 Gbps, set Bits[7:4] to 0x3 in Register 0x056E. When the serial line rate is ≤13.5 Gbps and >6.75 Gbps, set Bits[7:4] to 0x0 in Register 0x056E. When the serial line rate is ≤6.75 Gbps and >3.375 Gbps, set Bits[7:4] to 0x1 in Register 0x056E. When the serial line rate is ≤3.375 Gbps and ≥1687.5 Mbps, set Bits[7:4] to 0x5 in Register 0x056E.

² JESD204B transport layer descriptions are as described in the JESD204B Overview section.

³ For F = 1, K = 20, 24, 28, and 32. For F = 2, K = 12, 16, 20, 24, 28, and 32. For F = 4, K = 8, 12, 16, 20, 24, 28, and 32. For F = 8 and F = 16, K = 4, 8, 12, 16, 20, 24, 28, and 32.

Example 1: ADC with DDC Option (Two ADCs Plus Two DDCs in Each Pair)

The chip application mode is DDC mode (see Figure 100) with the following characteristics:

- Chip application mode = two DDC mode (see Figure 100)
- Two 14-bit converters at 500 MSPS
- Two DDC application layer mode with complex outputs (I/Q)
- Chip decimation ratio = 4
- DDC decimation ratio = 4 (see Table 34)

The JESD204B output configuration is as follows:

- Virtual converters required = 4 (see Table 34)
- Output sample rate (f_{OUT}) = $500/4 = 125$ MSPS
- $N' = 16$ bits

- $N = 16$ bits
- $L = 1, M = 4,$ and $F = 8$ (quick configuration = $0x13$)
- $CS = 0$ to 1
- $K = 32$
- Output serial line rate = 10 Gbps per lane ($L = 1$) or 5 Gbps per lane ($L = 2$)

For $L = 1$, set Bits[7:4] to $0x1$ in Register $0x056E$. For $L = 2$, set Bits[7:4] to $0x5$ in Register $0x056E$.

Example 1 shows the flexibility in the digital and lane configurations for the AD6684. The sample rate is 500 MSPS, but the outputs are all combined in either one or two lanes, depending on the I/O speed capability of the receiving device.

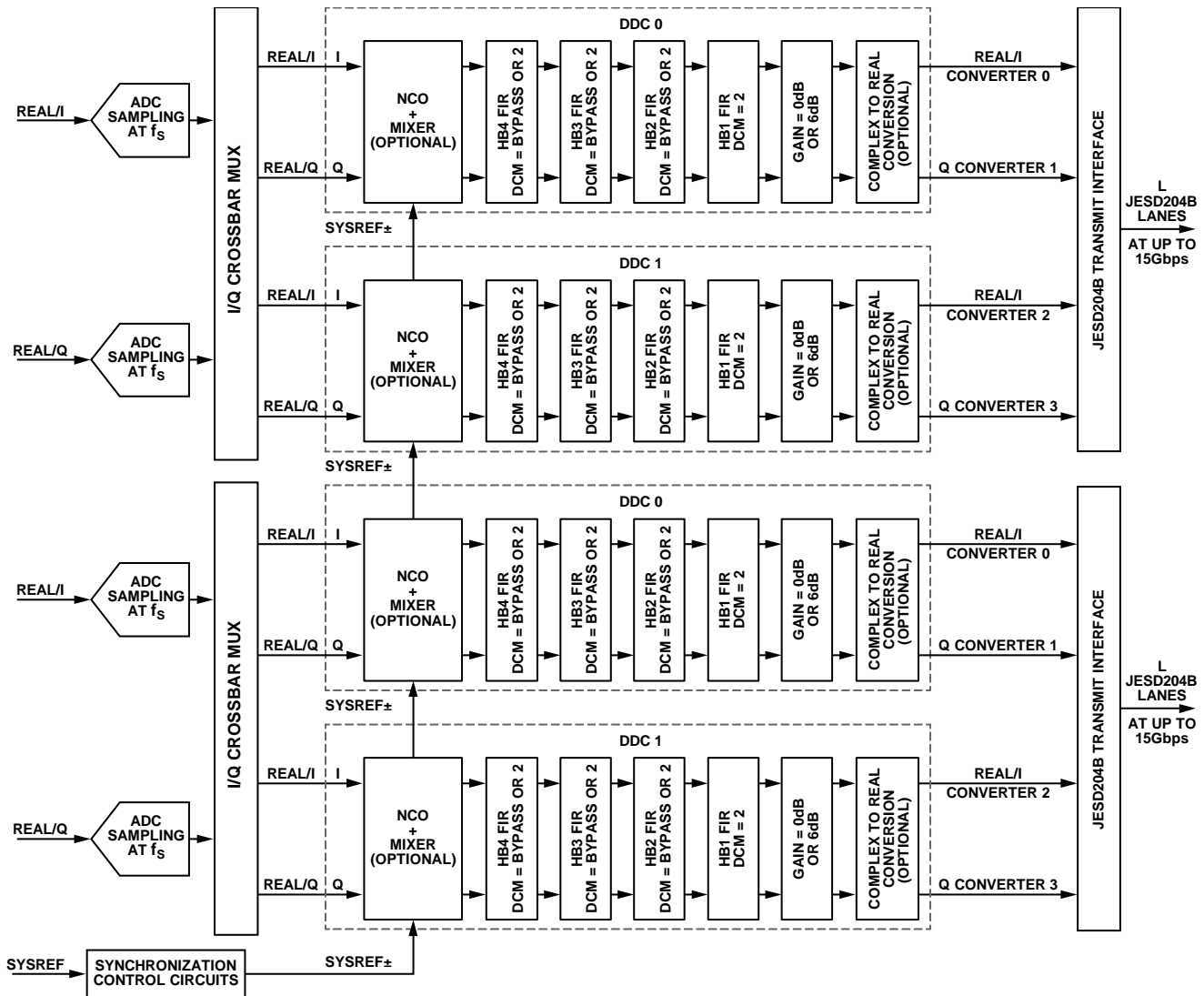

Figure 100. Two ADC + Four DDC Mode in Each Pair

14894-086

Example 2: ADC with NSR Option (Two ADCs + NSR in Each Pair)

The chip application mode is NSR mode (see Figure 101) with the following characteristics:

- Two 14-bit converters at 500 MSPS
- NSR blocks enabled for each channel
- Chip decimation ratio = 1

The JESD204B output configuration is as follows:

- Virtual converters required = 2 (see Table 34).
- Output sample rate (f_{OUT}) = 500 MSPS
- $N' = 16$ bits
- $N = 9$ bits
- $L = 2, M = 2,$ and $F = 2$ (quick configuration = 0x49)
- $CS = 0$ to 2
- $K = 32$
- Output serial lane rate = 10 Gbps per lane ($L = 2$)
 - Set Bits[7:4] to 0x0 in Register 0x056E

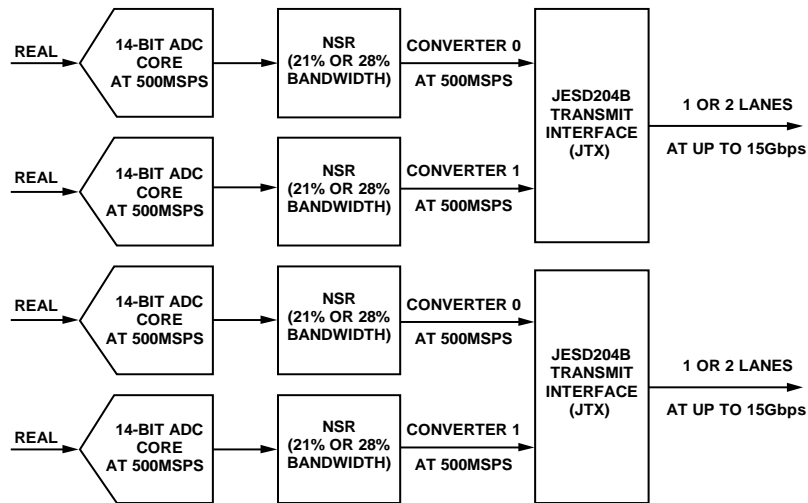

Figure 101. Two ADC + NSR Mode

LATENCY

END-TO-END TOTAL LATENCY

Total latency in the AD6684 is dependent on the various digital signal processing (DSP) and JESD204B configuration modes. Latency is fixed at 28 encode clocks through the ADC itself, but the latency through the DSP and JESD204B blocks can vary greatly, depending on the configuration. Therefore, the total

latency must be calculated based on the DSP options selected and the JESD204B configuration.

Table 37 shows the combined latency through the ADC, DSP, and JESD204B blocks for some of the different application modes supported by the AD6684. Latency is in units of the encode clock.

Table 37. Latency Through the AD6684

ADC Application Mode	JESD204B Transport Layer Settings			Latency (Number of Encode Clocks)		
	L	M	F	ADC + DSP	JESD204B	Total
Full Bandwidth (9-Bit)	2	2	2	30	14	44
DDC (HB1) ¹	2	4	4	92	17	109
DDC (HB2 + HB1) ¹	1	4	8	162	13	175
DDC (HB3 + HB2 + HB1) ¹	1	4	8	292	28	320
DDC (HB4 + HB3 + HB2 + HB1) ¹	1	4	8	548	39	587
Decimate by 2 + NSR	1	2	4	64	6	70
NSR	2	2	2	38	16	54

¹ No mixer, complex outputs.

MULTICHIP SYNCHRONIZATION

The AD6684 has a SYSREF \pm input that provides flexible options for synchronizing the internal blocks. The SYSREF \pm input is a source synchronous system reference signal that enables multichip synchronization. The input clock divider, DDCs, signal monitor block, and JESD204B link can be synchronized using the SYSREF \pm input. For the highest level of timing accuracy, SYSREF \pm must meet setup and hold requirements relative to the CLK \pm input.

The flowchart in Figure 102 describes the internal mechanism for multichip synchronization in the AD6684. The AD6684 supports several features that aid users in meeting the requirements set out for capturing a SYSREF \pm signal. The SYSREF sample event can be defined as either a synchronous low to high transition, or a synchronous high to low transition. Additionally, the AD6684 allows the SYSREF \pm signal to be sampled using either the rising edge or falling edge of the CLK \pm input. The AD6684 also has the ability to ignore a programmable number (up to 16) of SYSREF \pm events. The SYSREF \pm control options can be selected using Register 0x0120 and Register 0x0121.

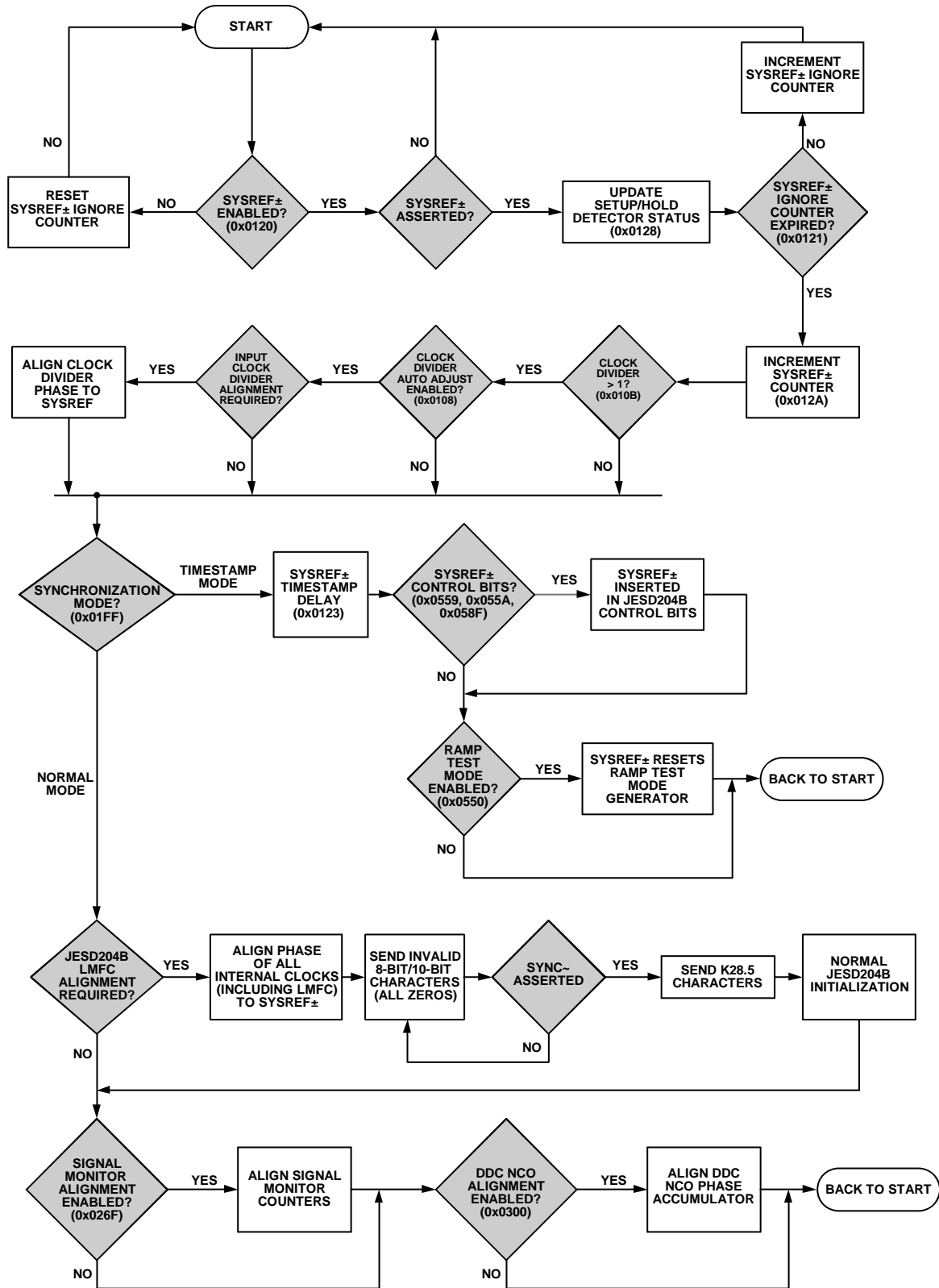

Figure 102. Multichip Synchronization

14954-088

SYSREF± SETUP/HOLD WINDOW MONITOR

To ensure a valid SYSREF signal capture, the AD6684 has a SYSREF± setup/hold window monitor. This feature allows the system designer to determine the location of the SYSREF± signals relative to the CLK± signals by reading back the amount of setup/hold margin on the interface through the memory map.

Figure 103 and Figure 104 show the setup and hold status values for different phases of SYSREF±. The setup detector returns the status of the SYSREF± signal before the CLK± edge, and the hold detector returns the status of the SYSREF± signal after the CLK± edge. Register 0x0128 stores the status of SYSREF± and lets the user know if the SYSREF± signal is captured by the ADC.

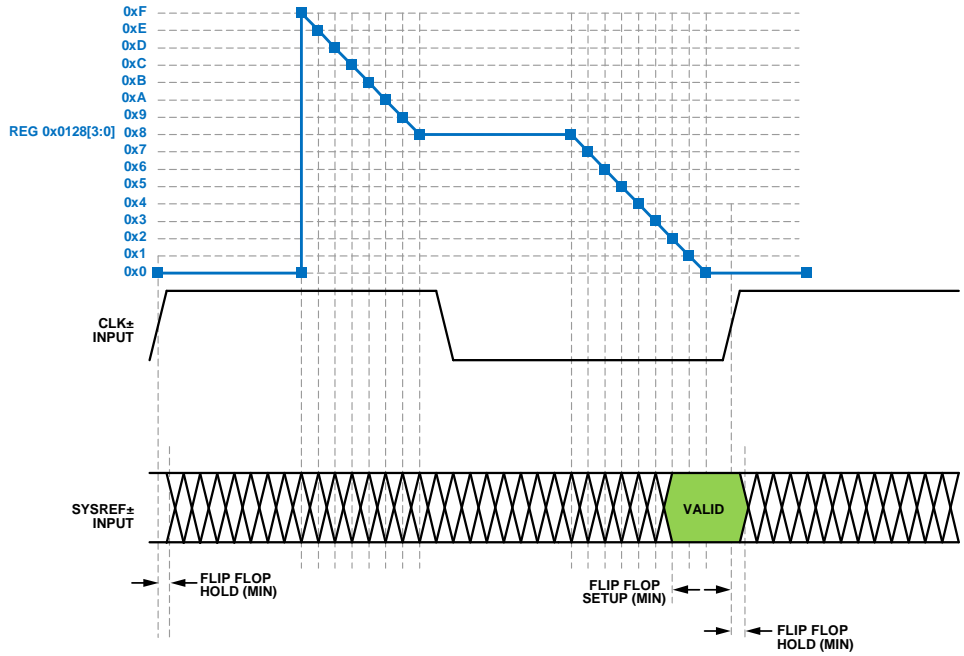

Figure 103. SYSREF± Setup Detector

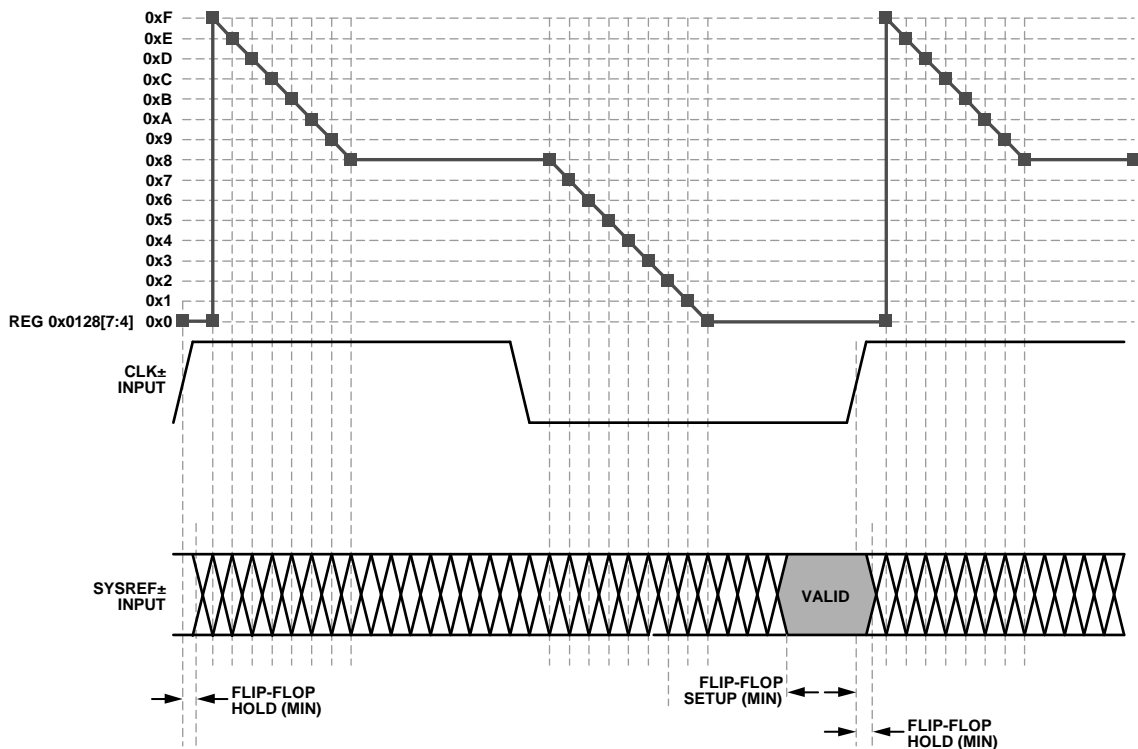

Figure 104. SYSREF± Hold Detector

14994-089

14994-090

Table 38 shows the description of the contents of Register 0x0128 and how to interpret them.

Table 38. SYSREF± Setup/Hold Monitor, Register 0x0128

Register 0x0128, Bits[7:4], Hold Status	Register 0x0128, Bits[3:0], Setup Status	Description
0x0	0x0 to 0x7	Possible setup error. The smaller this number, the smaller the setup margin.
0x0 to 0x8	0x8	No setup or hold error (best hold margin).
0x8	0x9 to 0xF	No setup or hold error (best setup and hold margin).
0x8	0x0	No setup or hold error (best setup margin).
0x9 to 0xF	0x0	Possible hold error. The larger this number, the smaller the hold margin.
0x0	0x0	Possible setup or hold error.

TEST MODES

ADC TEST MODES

The AD6684 has various test options that aid in the system level implementation. The AD6684 has ADC test modes that are available in Register 0x0550. These test modes are described in Table 39. When an output test mode is enabled, the analog section of the ADC is disconnected from the digital back-end blocks, and the test pattern is run through the output formatting block. Some of the test patterns are subject to output formatting, and some are not. The PN generators from the PN sequence tests can be reset by setting Bit 4 or Bit 5 of Register 0x0550. These tests can be performed with or without an analog signal (if

present, the analog signal is ignored); however, they do require an encode clock.

If the application mode is set to select a DDC mode of operation, the test modes must be enabled for each DDC enabled. The test patterns can be enabled via Bit 2 and Bit 0 of Register 0x0327, Register 0x0347, depending on which DDC(s) are selected. The (I) data uses the test patterns selected for Channel A, and the (Q) data uses the test patterns selected for Channel B. For more information, see the [AN-877 Application Note, Interfacing to High Speed ADCs via SPI](#).

Table 39. ADC Test Modes

Output Test Mode Bit Sequence	Pattern Name	Expression	Default/Seed Value	Sample (N, N + 1, N + 2, ...)
0000	Off (default)	Not applicable	Not applicable	Not applicable
0001	Midscale short	00 0000 0000 0000	Not applicable	Not applicable
0010	+Full-scale short	01 1111 1111 1111	Not applicable	Not applicable
0011	–Full-scale short	10 0000 0000 0000	Not applicable	Not applicable
0100	Checkerboard	10 1010 1010 1010	Not applicable	0x1555, 0x2AAA, 0x1555, 0x2AAA, 0x1555
0101	PN sequence long	$x^{23} + x^{18} + 1$	0x3AFF	0x3FD7, 0x0002, 0x26E0, 0x0A3D, 0x1CA6
0110	PN sequence short	$x^9 + x^5 + 1$	0x0092	0x125B, 0x3C9A, 0x2660, 0x0c65, 0x0697
0111	One word/zero word toggle	11 1111 1111 1111	Not applicable	0x0000, 0x3FFF, 0x0000, 0x3FFF, 0x0000
1000	User input	Register 0x0551 to Register 0x0558	Not applicable	User Pattern 1[15:2], User Pattern 2[15:2], User Pattern 3[15:2], User Pattern 4[15:2], User Pattern 1[15:2] ... for repeat mode User Pattern 1[15:2], User Pattern 2[15:2], User Pattern 3[15:2], User Pattern 4[15:2], 0x0000 ... for single mode
1111	Ramp output	$(x) \% 2^{14}$	Not applicable	$(x) \% 2^{14}, (x + 1) \% 2^{14}, (x + 2) \% 2^{14}, (x + 3) \% 2^{14}$

JESD204B BLOCK TEST MODES

In addition to the ADC pipeline test modes, the AD6684 also has flexible test modes in the JESD204B block. These test modes are listed in Register 0x0573 and Register 0x0574. These test patterns can be injected at various points along the output data-path. These test injection points are shown in Figure 89. Table 40 describes the various test modes available in the JESD204B block. For the AD6684, a transition from test modes (Register 0x0573 \neq 0x00) to normal mode (Register 0x0573 = 0x00) requires an SPI soft reset. This is done by writing 0x81 to Register 0x0000 (self cleared).

Transport Layer Sample Test Mode

The transport layer samples are implemented in the AD6684 as defined by Section 5.1.6.3 in the JEDEC JESD204B specification.

These tests indicated by the value of Register 0x0571, Bit 5. The test pattern is equivalent to the raw samples from the ADC.

Interface Test Modes

The interface test modes are described in Register 0x0573, Bits[3:0]. These test modes are also explained in Table 40. The interface tests can be injected at various points along the data. See Figure 89 for more information on the test injection points. Register 0x0573, Bits[5:4] show where these tests are injected.

Table 41, Table 42, and Table 43 show examples of some of the test modes when injected at the JESD204B sample input, PHY 10-bit input, and scrambler 8-bit input. In Table 41, Table 42, and Table 43, UPx represent the user pattern control bits from the customer register map.

Table 40. JESD204B Interface Test Modes

Output Test Mode Bit Sequence	Pattern Name	Expression	Default
0000	Off (default)	Not applicable	Not applicable
0001	Alternating checkerboard	0x5555, 0xAAAA, 0x5555, ...	Not applicable
0010	1/0 word toggle	0x0000, 0xFFFF, 0x0000, ...	Not applicable
0011	31-bit PN sequence	$x^{31} + x^{28} + 1$	0x0003AFFF
0100	23-bit PN sequence	$x^{23} + x^{18} + 1$	0x003AFF
0101	15-bit PN sequence	$x^{15} + x^{14} + 1$	0x03AF
0110	9-bit PN sequence	$x^9 + x^5 + 1$	0x092
0111	7-bit PN sequence	$x^7 + x^6 + 1$	0x07
1000	Ramp output	$(x) \% 2^{16}$	Ramp size depends on test injection point
1110	Continuous/repeat user test	Register 0x0551 to Register 0x0558	User Pattern 1 to User Pattern 4, then repeat
1111	Single user test	Register 0x0551 to Register 0x0558	User Pattern 1 to User Pattern 4, then zeros

Table 41. JESD204B Sample Input for M = 2, S = 2, N' = 16 (Register 0x0573, Bits[5:4] = 'b00)

Frame Number	Converter Number	Sample Number	Alternating Checkerboard	1/0 Word Toggle	Ramp	9-Bit PN	23-Bit PN	User Repeat	User Single
0	0	0	0x5555	0x0000	$(x) \% 2^{16}$	0x496F	0xFF5C	UP1[15:0]	UP1[15:0]
0	0	1	0x5555	0x0000	$(x) \% 2^{16}$	0x496F	0xFF5C	UP1[15:0]	UP1[15:0]
0	1	0	0x5555	0x0000	$(x) \% 2^{16}$	0x496F	0xFF5C	UP1[15:0]	UP1[15:0]
0	1	1	0x5555	0x0000	$(x) \% 2^{16}$	0x496F	0xFF5C	UP1[15:0]	UP1[15:0]
1	0	0	0xAAAA	0xFFFF	$(x + 1) \% 2^{16}$	0xC9A9	0x0029	UP2[15:0]	UP2[15:0]
1	0	1	0xAAAA	0xFFFF	$(x + 1) \% 2^{16}$	0xC9A9	0x0029	UP2[15:0]	UP2[15:0]
1	1	0	0xAAAA	0xFFFF	$(x + 1) \% 2^{16}$	0xC9A9	0x0029	UP2[15:0]	UP2[15:0]
1	1	1	0xAAAA	0xFFFF	$(x + 1) \% 2^{16}$	0xC9A9	0x0029	UP2[15:0]	UP2[15:0]
2	0	0	0x5555	0x0000	$(x + 2) \% 2^{16}$	0x980C	0xB80A	UP3[15:0]	UP3[15:0]
2	0	1	0x5555	0x0000	$(x + 2) \% 2^{16}$	0x980C	0xB80A	UP3[15:0]	UP3[15:0]
2	1	0	0x5555	0x0000	$(x + 2) \% 2^{16}$	0x980C	0xB80A	UP3[15:0]	UP3[15:0]
2	1	1	0x5555	0x0000	$(x + 2) \% 2^{16}$	0x980C	0xB80A	UP3[15:0]	UP3[15:0]
3	0	0	0xAAAA	0xFFFF	$(x + 3) \% 2^{16}$	0x651A	0x3D72	UP4[15:0]	UP4[15:0]
3	0	1	0xAAAA	0xFFFF	$(x + 3) \% 2^{16}$	0x651A	0x3D72	UP4[15:0]	UP4[15:0]
3	1	0	0xAAAA	0xFFFF	$(x + 3) \% 2^{16}$	0x651A	0x3D72	UP4[15:0]	UP4[15:0]
3	1	1	0xAAAA	0xFFFF	$(x + 3) \% 2^{16}$	0x651A	0x3D72	UP4[15:0]	UP4[15:0]
4	0	0	0x5555	0x0000	$(x + 4) \% 2^{16}$	0x5FD1	0x9B26	UP1[15:0]	0x0000
4	0	1	0x5555	0x0000	$(x + 4) \% 2^{16}$	0x5FD1	0x9B26	UP1[15:0]	0x0000
4	1	0	0x5555	0x0000	$(x + 4) \% 2^{16}$	0x5FD1	0x9B26	UP1[15:0]	0x0000
4	1	1	0x5555	0x0000	$(x + 4) \% 2^{16}$	0x5FD1	0x9B26	UP1[15:0]	0x0000

Table 42. Physical Layer 10-Bit Input (Register 0x0573, Bits[5:4] = 'b01)

10-Bit Symbol Number	Alternating Checkerboard	1/0 Word Toggle	Ramp	9-Bit PN	23-Bit PN	User Repeat	User Single
0	0x155	0x000	$(x) \% 2^{10}$	0x125	0x3FD	UP1[15:6]	UP1[15:6]
1	0x2AA	0x3FF	$(x + 1) \% 2^{10}$	0x2FC	0x1C0	UP2[15:6]	UP2[15:6]
2	0x155	0x000	$(x + 2) \% 2^{10}$	0x26A	0x00A	UP3[15:6]	UP3[15:6]
3	0x2AA	0x3FF	$(x + 3) \% 2^{10}$	0x198	0x1B8	UP4[15:6]	UP4[15:6]
4	0x155	0x000	$(x + 4) \% 2^{10}$	0x031	0x028	UP1[15:6]	0x000
5	0x2AA	0x3FF	$(x + 5) \% 2^{10}$	0x251	0x3D7	UP2[15:6]	0x000
6	0x155	0x000	$(x + 6) \% 2^{10}$	0x297	0x0A6	UP3[15:6]	0x000
7	0x2AA	0x3FF	$(x + 7) \% 2^{10}$	0x3D1	0x326	UP4[15:6]	0x000
8	0x155	0x000	$(x + 8) \% 2^{10}$	0x18E	0x10F	UP1[15:6]	0x000
9	0x2AA	0x3FF	$(x + 9) \% 2^{10}$	0x2CB	0x3FD	UP2[15:6]	0x000
10	0x155	0x000	$(x + 10) \% 2^{10}$	0x0F1	0x31E	UP3[15:6]	0x000
11	0x2AA	0x3FF	$(x + 11) \% 2^{10}$	0x3DD	0x008	UP4[15:6]	0x000

Table 43. Scrambler 8-Bit Input (Register 0x0573, Bits[5:4] = 'b10)

8-Bit Octet Number	Alternating Checkerboard	1/0 Word Toggle	Ramp	9-Bit PN	23-Bit PN	User Repeat	User Single
0	0x55	0x00	$(x) \% 2^8$	0x49	0xFF	UP1[15:9]	UP1[15:9]
1	0xAA	0xFF	$(x + 1) \% 2^8$	0x6F	0x5C	UP2[15:9]	UP2[15:9]
2	0x55	0x00	$(x + 2) \% 2^8$	0xC9	0x00	UP3[15:9]	UP3[15:9]
3	0xAA	0xFF	$(x + 3) \% 2^8$	0xA9	0x29	UP4[15:9]	UP4[15:9]
4	0x55	0x00	$(x + 4) \% 2^8$	0x98	0xB8	UP1[15:9]	0x00
5	0xAA	0xFF	$(x + 5) \% 2^8$	0x0C	0x0A	UP2[15:9]	0x00
6	0x55	0x00	$(x + 6) \% 2^8$	0x65	0x3D	UP3[15:9]	0x00
7	0xAA	0xFF	$(x + 7) \% 2^8$	0x1A	0x72	UP4[15:9]	0x00
8	0x55	0x00	$(x + 8) \% 2^8$	0x5F	0x9B	UP1[15:9]	0x00
9	0xAA	0xFF	$(x + 9) \% 2^8$	0xD1	0x26	UP2[15:9]	0x00
10	0x55	0x00	$(x + 10) \% 2^8$	0x63	0x43	UP3[15:9]	0x00
11	0xAA	0xFF	$(x + 11) \% 2^8$	0xAC	0xFF	UP4[15:9]	0x00

Data Link Layer Test Modes

The data link layer test modes are implemented in the AD6684 as defined by Section 5.3.3.8.2 in the JEDEC JESD204B specification. These tests are shown in Register 0x0574, Bits[2:0]. Test

patterns inserted at this point are useful for verifying the functionality of the data link layer. When the data link layer test modes are enabled, disable SYNCINB±AB/SYNCINB±CD by writing 0xC0 to Register 0x0572.

SERIAL PORT INTERFACE

The AD6684 SPI allows the user to configure the converter for specific functions or operations through a structured register space provided inside the ADC. The SPI gives the user added flexibility and customization, depending on the application. Addresses are accessed via the serial port and can be written to or read from the port. Memory is organized into bytes that can be further divided into fields. These fields are documented in the Memory Map section. For detailed operational information, see the [Serial Control Interface Standard \(Rev. 1.0\)](#).

CONFIGURATION USING THE SPI

Three pins define the SPI of this ADC: the SCLK pin, the SDIO pin, and the CSB pin (see Table 44). The SCLK (serial clock) pin is used to synchronize the read and write data presented from and to the ADC. The SDIO (serial data input/output) pin is a dual-purpose pin that allows data to be sent and read from the internal ADC memory map registers. The CSB (chip select bar) pin is an active low control that enables or disables the read and write cycles.

Table 44. Serial Port Interface Pins

Pin	Function
SCLK	Serial clock. The serial shift clock input, which is used to synchronize serial interface reads and writes.
SDIO	Serial data input/output. A dual-purpose pin that typically serves as an input or an output, depending on the instruction being sent and the relative position in the timing frame.
CSB	Chip select bar. An active low control that gates the read and write cycles.

The falling edge of CSB, in conjunction with the rising edge of SCLK, determines the start of the framing. An example of the serial timing and its definitions can be found in Figure 4 and Table 5.

Other modes involving the CSB pin are available. The CSB pin can be held low indefinitely, which permanently enables the device; this is called streaming. The CSB can stall high between bytes to allow for additional external timing. When CSB is tied high, SPI functions are placed in a high impedance mode. This mode turns on the secondary functions of the SPI pin.

All data is composed of 8-bit words. The first bit of each individual byte of serial data indicates whether a read or write

Table 45. Features Accessible Using the SPI

Feature Name	Description
Mode	Allows the user to set either power-down mode or standby mode.
Clock	Allows the user to access the clock divider via the SPI.
DDC	Allows the user to set up decimation filters for different applications.
Test Input/Output	Allows the user to set test modes to have known data on output bits.
Output Mode	Allows the user to set up outputs.
SERDES Output Setup	Allows the user to vary SERDES settings such as swing and emphasis.

command is issued. This bit allows the SDIO pin to change direction from an input to an output.

In addition to word length, the instruction phase determines whether the serial frame is a read or write operation, allowing the serial port to be used both to program the chip and to read the contents of the on-chip memory. If the instruction is a readback operation, performing a readback causes the SDIO pin to change direction from an input to an output at the appropriate point in the serial frame.

Data can be sent in MSB first mode or in LSB first mode. MSB first mode is the default on power-up and can be changed via the SPI port configuration register. For more information about this and other features, see the [Serial Control Interface Standard \(Rev. 1.0\)](#).

HARDWARE INTERFACE

The pins described in Table 44 comprise the physical interface between the user programming device and the serial port of the AD6684. The SCLK pin and the CSB pin function as inputs when using the SPI interface. The SDIO pin is bidirectional, functioning as an input during write phases and as an output during readback.

The SPI interface is flexible enough to be controlled by either FPGAs or microcontrollers. One method for SPI configuration is described in detail in the [AN-812 Application Note, Microcontroller-Based Serial Port Interface \(SPI\) Boot Circuit](#).

Do not activate the SPI port during periods when the full dynamic performance of the converter is required. Because the SCLK signal, the CSB signal, and the SDIO signal are typically asynchronous to the ADC clock, noise from these signals can degrade converter performance. If the on-board SPI bus is used for other devices, it may be necessary to provide buffers between this bus and the AD6684 to prevent these signals from transitioning at the converter inputs during critical sampling periods.

SPI ACCESSIBLE FEATURES

Table 45 provides a brief description of the general features that are accessible via the SPI. These features are described in detail in the [Serial Control Interface Standard \(Rev. 1.0\)](#). The AD6684 device specific features are described in the Memory Map section.

MEMORY MAP

READING THE MEMORY MAP REGISTER TABLE

Each row in the memory map register table has eight bit locations. The memory map is divided into four sections: the Analog Devices SPI registers (Register 0x0000 to Register 0x000D and Register 0x18A6 to Register 0x1A4D), the ADC function registers (Register 0x003F to Register 0x027A), the DDC, NSR, and VDR function registers (Register 0x0300 to Register 0x0434), and the digital outputs and test modes registers (Register 0x0550 to Register 0x05C6).

Open and Reserved Locations

All address and bit locations that are not included in Table 46 are not currently supported for this device. Write unused bits of a valid address location with 0s unless the default value is set otherwise. Writing to these locations is required only when part of an address location is unassigned (for example, Address 0x0561). If the entire address location is open (for example, Address 0x0013), do not write to this address location.

Default Values

After the AD6684 is reset, critical registers are loaded with default values. The default values for the registers are given in the memory map register table, Table 46.

Logic Levels

An explanation of logic level terminology follows:

- “Bit is set” is synonymous with “bit is set to Logic 1” or “writing Logic 1 for the bit.”
- “Clear a bit” is synonymous with “bit is set to Logic 0” or “writing Logic 0 for the bit.”
- X denotes a don't care bit.

ADC Pair Addressing

The AD6684 functionally operates as two pairs of dual IF receiver channels. There are two ADCs, two NSR processing blocks, two VDR processing blocks, and two DDCs in each pair, resulting in a total of four of each for the AD6684. To access the SPI registers for each pair, the pair index must be written in Register 0x0009. The pair index register must be written prior to any other SPI write to the AD6684.

Channel-Specific Registers

Some channel setup functions, such as the fast detect control (Register 0x0247), can be programmed to a different value for each channel. In these cases, channel address locations are

internally duplicated for each channel. These registers and bits are designated in Table 46 as local. These local registers and bits can be accessed by setting the appropriate Channel A/Channel C or Channel B/Channel D bits in Register 0x0008. The particular channel that is addressed is dependent upon the pair selection written to Register 0x0009. If both bits are set, the subsequent write affects the registers of both channels. In a read cycle, set only Channel A/Channel C or Channel B/Channel D to read one of the two registers. If both bits are set during an SPI read cycle, the device returns the value for Channel A. If both pairs and both channels have been selected via Register 0x0009 and Register 0x0008, then the device returns the value for Channel A.

The names of the registers listed in Table 46 are prefixed with either global map, channel map, JESD204B map, or pair map. Registers in the pair map and JESD204B map apply to a pair of channels, either Pair A/B or Pair C/D. To write registers in the pair map and the JESD204B map, the pair index register (Register 0x0009) must be written to address the appropriate pair. The SPI Configuration A (Register 0x0000), SPI Configuration B (Register 0x0001), and pair index (Register 0x0009) registers are the only registers that reside in the global map. Registers in the channel map are local to each channel, either Channel A, Channel B, Channel C, or Channel D. To write registers in the channel map, the pair index register (Register 0x0009) must be written first to address the desired pair (Pair A/B or Pair C/D), followed by writing the channel index register (Register 0x0008) to select the desired channel (Channel A/Channel C or Channel B/Channel D). For example, to write Channel A to a test mode (set by Register 0x0550), first write a value of 0x01 to Register 0x0009 to select Pair A/B, followed by writing 0x01 to Register 0x0008 to select Channel A. Then, write Register 0x0550 to the value for the desired test mode. To write all channels to a test mode (set by Register 0x0550), first write Register 0x0009 to a value of 0x03 to select both Pair A/B and Pair C/D, followed by writing Register 0x0008 to a value of 0x03 to select Channel A, Channel B, Channel C, and Channel D. Next, write Register 0x0550 to the value for the desired test mode.

SPI Soft Reset

After issuing a soft reset by programming 0x81 to Register 0x0000, the AD6684 requires 5 ms to recover. When programming the AD6684 for application setup, ensure that an adequate delay is programmed into the firmware after asserting the soft reset and before starting the device setup.

MEMORY MAP

MEMORY MAP DETAILS

All address locations that are not included in Table 46 are not currently supported for this device and must not be written.

Table 46. Memory Map Details

Address	Name	Bits	Bit Name	Settings	Description	Reset	Access
0x0000	Global Map SPI Config- uration A	7	Soft reset (self clearing)	0	When a soft reset is issued, the user must wait 5 ms before writing to any other register. This wait provides sufficient time for the boot loader to complete. Do nothing.	0x0	R/W
				1	Reset the SPI and registers (self clearing).		
		6	LSB first mirror	1	LSB shifted first for all SPI operations.	0x0	R/W
				0	MSB shifted first for all SPI operations.		
		5	Address ascension mirror	0	Multibyte SPI operations cause addresses to auto-increment.	0x0	R/W
				1	Multibyte SPI operations cause addresses to auto-increment.		
		[4:3]	Reserved		Reserved.	0x0	R
		2	Address ascension	0	Multibyte SPI operations cause addresses to autoincrement.	0x0	R/W
1	Multibyte SPI operations cause addresses to auto increment.						
1	LSB first	1	LSB shifted first for all SPI operations.	0x0	R/W		
0	Soft reset (self clearing)	0	When a soft reset is issued, the user must wait 5 ms before writing to any other register. This wait provides sufficient time for the boot loader to complete. Do nothing.				
		1	Reset the SPI and registers (self clearing).				
0x0001	Global Map SPI Config- uration B	7	Single instruction	0	SPI streaming enabled.	0x0	R/W
				1	Streaming (multibyte read/write) is disabled. Only one read or write operation is performed, regardless of the state of the CSB line.		
		[6:2]	Reserved		Reserved.	0x0	R
		1	Datapath soft reset (self clearing)	0	Normal operation.	0x0	R/W
1	Datapath soft reset (self-clearing).						
0	Reserved		Reserved.	0x0	R		

Address	Name	Bits	Bit Name	Settings	Description	Reset	Access
0x0002	Channel map chip configuration	[7:2]	Reserved		Reserved.	0x0	R
		[1:0]	Channel power modes	00	Normal mode (power up).	0x0	R/W
				10	Standby mode. The digital datapath clocks are disabled, the JESD204B interface is enabled, and the outputs are enabled.		
				11	Power-down mode. The digital datapath clocks are disabled, the digital datapath is held in reset, the JESD204B interface is disabled, and the outputs are disabled.		
0x0003	Pair map chip type	[7:0]	CHIP_TYPE	0x3	Chip type. High speed ADC.	0x3	R
0x0004	Pair map chip ID LSB	[7:0]	CHIP_ID		Chip ID.	0xDC	R
0x0006	Pair map chip grade	[7:4]	CHIP_SPEED_GRADE	0101	Chip speed grade. 500 MHz.	0x0	R
		[3:0]	Reserved		Reserved.	0x0	R
0x0008	Pair map device index	[7:2]	Reserved		Reserved.	0x0	R
		1	Channel B/Channel D	0	ADC Core B/ADC Core D does not receive the next SPI command.	0x1	R/W
				1	ADC Core B/ADC Core D receives the next SPI command.		
		0	Channel A/Channel C	0	ADC Core A/ADC Core C does not receive the next SPI command.	0x1	R/W
1	ADC Core A/ADC Core C receives the next SPI command.						
0x0009	Global map pair index	[7:2]	Reserved		Reserved.	0x0	R
		1	Pair C/D	0	ADC Pair C/D does not receive the next read/write command from the SPI interface.	0x1	R/W
				1	ADC Pair C/D does not receive the next read/write command from the SPI interface.		
		0	Pair A/B	0	ADC Pair A/B does not receive the next read/write command from the SPI interface.	0x1	R/W
				1	ADC Pair A/B receives the next read/write command from the SPI interface.		
0x000A	Pair map scratch pad	[7:0]	Scratch pad		Chip scratch pad register. This register provides a consistent memory location for software debug.	0x07	R/W
0x000B	Pair map SPI revision	[7:0]	SPI_REVISION	00000001	SPI revision register (0x01 = Revision 1.0). Revision 1.0.	0x1	R
0x000C	Pair map vendor ID LSB	[7:0]	CHIP_VENDOR_ID[7:0]		Vendor ID.	0x56	R
0x000D	Pair map vendor ID MSB	[7:0]	CHIP_VENDOR_ID[15:8]		Vendor ID.	0x4	R

Address	Name	Bits	Bit Name	Settings	Description	Reset	Access		
0x003F	Channel map chip power-down pin	7	PDWN/STBY disable	0 1	This bit is used in conjunction with Register 0x0040. Power-down pin (PDWN/STBY) enabled; global pin control selection enabled (default). Power-down pin (PDWN/STBY) disabled/ignored; global pin control selection ignored.	0x0	R/W		
		[6:0]	Reserved		Reserved.	0x0	R		
0x0040	Pair Map Chip Pin Control 1	[7:6]	PDWN/STBY function	00 01 10	Power-down pin—assertion of the external power-down pin (PDWN/STBY) causes the chip to enter full power-down mode. Standby pin—assertion of the external power-down pin (PDWN/STBY) causes the chip to enter standby mode. Pin disabled—assertion of the external power-down pin (PDWN/STBY) is ignored.	0x0	R/W		
				[5:3]	Fast Detect B/Fast Detect D (FD_B/FD_D)	000 001 010 111	Fast Detect B/Fast Detect D output. JESD204B LMFC output. JESD204B internal SYNC signal in the ADC output. Disabled (configured as an input with a weak pull down).	0x7	R/W
						[2:0]	Fast Detect A/Fast Detect C (FD_A/FD_C)	000 001 010 111	Fast Detect A/Fast Detect C output. JESD204B LMFC output. JESD204B internal SYNC signal in the ADC output. Disabled (configured as an input with a weak pull down).
0x0108	Pair map clock divider control	[7:3]	Reserved		Reserved.			0x0	R
		[2:0]	Clock divider	000 001 011 111	Divide by 1. Divide by 2. Divide by 4. Divide by 8.	0x1	R/W		
0x0109	Channel map clock divider phase	[7:4]	Reserved		Reserved.	0x0	R		
		[3:0]	Clock divider phase offset	0000 0001 0010 0011 0100 0101 0110 0111 1000 1001 1010 1011	0 input clock cycles delayed. 1/2 input clock cycles delayed (invert clock). 1 input clock cycles delayed. 1 1/2 input clock cycles delayed. 2 input clock cycles delayed. 2 1/2 input clock cycles delayed. 3 input clock cycles delayed. 3 1/2 input clock cycles delayed. 4 input clock cycles delayed. 4 1/2 input clock cycles delayed. 5 input clock cycles delayed. 5 1/2 input clock cycles delayed.	0x0	R/W		

Address	Name	Bits	Bit Name	Settings	Description	Reset	Access
				1100 1101 1110 1111	6 input clock cycles delayed. 6 1/2 input clock cycles delayed. 7 input clock cycles delayed. 7 1/2 input clock cycles delayed.		
0x010A	Pair map clock divider SYSREF control	7	Clock divider auto phase adjust	0	Clock divider phase is not changed by SYSREF (disabled).	0x0	R/W
				1	Clock divider phase is automatically adjusted by SYSREF (enabled).		
		[6:4]	Reserved		Reserved.	0x0	R
		[3:2]	Clock divider negative skew window	00	No negative skew; SYSREF must be captured accurately.	0x0	R/W
				01	1/2 device clock of negative skew.		
10	1 device clocks of negative skew.						
11	1 1/2 device clocks of negative skew.						
[1:0]	Clock divider positive skew window	00	No positive skew; SYSREF must be captured accurately.	0x0	R/W		
		01	1/2 device clock of positive skew.				
		10	1 device clocks of positive skew.				
		11	1 1/2 device clocks of positive skew.				
0x0110	Pair map clock delay control	[7:3]	Reserved		Reserved.	0x0	R
		[2:0]	Clock delay mode select	000 001 010 011 100 101 110	Clock delay mode select; used in conjunction with Register 0x0111 and Register 0x0112. No clock delay. Reserved. Fine delay; only Delay Step 0 to Delay Step 16 are valid. Fine delay (lowest jitter); only Delay Step 0 to Delay Step 16 are valid. Fine delay; all 192 delay steps are valid. Reserved (same as 001). Fine delay enabled; all 192 delay steps are valid. Super fine delay enabled (all 128 delay steps are valid).	0x0	R/W
0x0111	Channel map clock super fine delay	[7:0]	Clock super fine delay adjust	0x00 ... 0x08 ... 0x80	This is an unsigned control to adjust the super fine sample clock delay in 0.25 ps steps. 0 delay steps. ... 8 delay steps. ... 128 delay steps. These bits are only used when Register 0x0110, Bits[2:0] = 0x2 or 0x6.	0x0	R/W

Address	Name	Bits	Bit Name	Settings	Description	Reset	Access
0x0112	Channel map clock fine delay	[7:0]	Clock fine delay adjust	0x00 ... 0x08 ... 0xC0	Clock fine delay adjust. This is an unsigned control to adjust the fine sample clock skew in 1.725 ps steps. 0 delay steps. ... 8 delay steps. ... 192 delay steps. These bits are only used when Register 0x0110, Bits[2:0] = 0x2, 0x3, 0x4, or 0x6.	0xC0	R/W
0x011A	Clock detection control	[7:5]	Reserved		Reserved.	0x0	R/W
		[4:3]	Clock detection threshold	01 11	Clock detection threshold. 200 MHz. 150 MHz.	0x1	R/W
		2	Clock detection enable	1 0	Clock detection enable Enable. Disable.	0x1	R/W
		[1:0]	Reserved.		Reserved.	0x2	R/W
0x011B	Pair map clock status	[7:1]	Reserved		Reserved.	0x0	R
		0	Input clock detect	0 1	Clock detection status. Input clock not detected. Input clock detected/locked.	0x0	R
0x011C	Clock DCS control	[7:3]	Reserved		Reserved.	0x1	R/W
		1	Clock DCS enable	0 1	Clock DCS enable. DCS bypassed. DCS enabled.	0x0	R/W
		0	Clock DCS power-up	0 1	Clock DCS power-up. DCS powered down. DCS powered up. The DCS must be powered up before being enabled.	0x0	R/W
0x0120	Pair map SYSREF Control 1	7	Reserved		Reserved.	0x0	R
		6	SYSREF± flag reset	0 1	Normal flag operation. SYSREF± flags held in reset (setup/hold error flags cleared).	0x0	R/W
		5	Reserved		Reserved.	0x0	R
		4	SYSREF± transition select	0 1	SYSREF± is valid on low to high transitions using the selected CLK input edge. When changing this setting, the SYSREF± mode select must be set to disabled. SYSREF± is valid on high to low transitions using the selected CLK input edge. When changing this setting, the SYSREF± mode select must be set to disabled.	0x0	R/W
		3	CLK± edge select	0 1	Captured on rising edge of CLK input. Captured on falling edge of CLK input.	0x0	R/W
		[2:1]	SYSREF± mode select	00 01 10	Disabled. Continuous. N shot.	0x0	R/W
		0	Reserved		Reserved.	0x0	R

Address	Name	Bits	Bit Name	Settings	Description	Reset	Access
0x0121	Pair map SYSREF Control 2	[7:4]	Reserved		Reserved.	0x0	R
		[3:0]	SYSREF N shot ignore counter select	0000	Next SYSREF± only (do not ignore).	0x0	R/W
				0001	Ignore the first SYSREF± transition.		
				0010	Ignore the first two SYSREF± transitions.		
				0011	Ignore the first three SYSREF± transitions.		
				0100	Ignore the first four SYSREF± transitions.		
				0101	Ignore the first five SYSREF± transitions.		
				0110	Ignore the first six SYSREF± transitions.		
				0111	Ignore the first seven SYSREF± transitions.		
				1000	Ignore the first eight SYSREF± transitions.		
				1001	Ignore the first nine SYSREF± transitions.		
				1010	Ignore the first 10 SYSREF± transitions.		
				1011	Ignore the first 11 SYSREF± transitions.		
				1100	Ignore the first 12 SYSREF± transitions.		
				1101	Ignore the first 13 SYSREF± transitions.		
				1110	Ignore the first 14 SYSREF± transitions.		
1111	Ignore the first 15 SYSREF± transitions.						
0x0123	Pair map SYSREF Control 4	7	Reserved		Reserved.	0x0	R
		[6:0]	SYSREF± time stamp delay[6:0]		SYSREF± timestamp delay (in converter sample clock cycles)	0x40	R/W
				0	0 sample clock cycle delay		
				1	1 sample clock cycle delay		
127	127 sample clock cycle delay						
0x0128	Pair map SYSREF Status 1	[7:4]	SYSREF± hold status[7:4]		SYSREF± hold status. See Table 38 for more information.	0x0	R
		[3:0]	SYSREF± setup status[3:0]		SYSREF± setup status. See Table 38 for more information.	0x0	R
0x0129	Pair map SYSREF Status 2	[7:4]	Reserved		Reserved.	0x0	R
		[3:0]	Clock divider phase when SYSREF± is captured		SYSREF± divider phase. These bits represent the phase of the divider when SYSREF± is captured.	0x0	R
				0000	In phase.		
				0001	SYSREF± is ½ cycle delayed from clock.		
				0010	SYSREF± is 1 cycle delayed from clock.		
				0011	1½ input clock cycles delayed.		
				0100	2 input clock cycles delayed.		
				0101	2½ input clock cycles delayed.		
1111	7½ input clock cycles delayed.						
0x012A	Pair map SYSREF Status 3	[7:0]	SYSREF± counter [7:0] (increments when a SYSREF± is captured)		SYSREF± count. These bits are a running counter that increments whenever a SYSREF± event is captured. These bits are reset by Register 0x0120, Bit 6, and wrap around at 255. Read these bits only while Register 0x120, Bits[2:1] are disabled.	0x0	R

Address	Name	Bits	Bit Name	Settings	Description	Reset	Access
0x01FF	Pair map chip sync	[7:1]	Reserved		Reserved.	0x0	R
		0	Synchronization mode	0x0 0x1	Sample synchronization mode. The SYSREF± signal resets all internal sample dividers. Use this mode when synchronizing multiple chips as specified in the JESD204B standard. If the phase of any of the dividers must change, the JESD204B link is interrupted. Partial synchronization/timestamp mode. The SYSREF± signal does not reset sample internal dividers. In this mode, the JESD204B link, the signal monitor, and the parallel interface clocks are not affected by the SYSREF± signal. The SYSREF signal simply time stamps a sample as it passes through the ADC.	0x0 0x0	R/W
0x0200	Pair map chip mode	[7:6]	Reserved		Reserved.	0x0	R/W
		5	Chip Q ignore	0 1	Chip real (I) only selection. Both real (I) and complex (Q) selected. Only real (I) selected. Complex (Q) is ignored.	0x0	R/W
		4	Reserved		Reserved.	0x0	R
		[3:0]	Chip application mode	0000 0001 0010 0111 1000	Full bandwidth mode. One DDC mode (DDC 0 only). Two DDC mode (DDC 0 and DDC 1 only). Noise shaped requantizer (NSR) mode. Variable dynamic range (VDR) mode.	0x7	R/W
0x0201	Pair map chip decimation ratio	[7:3]	Reserved		Reserved.	0x0	R
		[2:0]	Chip decimation ratio select	000 001 010 011 100	Chip decimation ratio. Decimate by 1 (full sample rate). Decimate by 2. Decimate by 4. Decimate by 8. Decimate by 16.	0x0	R/W
0x0228	Channel map custom offset	[7:0]	Offset adjust in LSBs from +127 to -128		Digital datapath offset. Twos complement offset adjustment aligned with least significant converter resolution bit.	0x0	R/W
0x0245	Channel map fast detect control	[7:4]	Reserved		Reserved.	0x0	R
		3	Force FD_A/FD_B/FD_C/ FD_D pins	0 1	Normal operation of the fast detect pin. Force a value on the fast detect pin (see Bit 2 of this register).	0x0	R/W
		2	Force value of FD_A/FD_B/ FD_C/FD_D pins; if force pins is true, this value is output on the fast detect pins		The fast detect output pin for this channel is set to this value when the output is forced.	0x0	R/W
		1	Reserved		Reserved.	0x0	R
		0	Enable fast detect output	0 1	Fine fast detect disabled. Fine fast detect enabled.	0x0	R/W

Address	Name	Bits	Bit Name	Settings	Description	Reset	Access
0x0247	Channel map fast detect upper threshold LSB	[7:0]	Fast detect upper threshold [7:0]		LSBs of fast detect upper threshold. Eight LSBs of the programmable 13-bit upper threshold that is compared to the fine ADC magnitude.	0x0	R/W
0x0248	Channel map fast detect upper threshold MSB	[7:5]	Reserved		Reserved.	0x0	R
		[4:0]	Fast detect upper threshold[12:8]		LSBs of fast detect upper threshold. Eight LSBs of the programmable 13-bit upper threshold that is compared to the fine ADC magnitude.	0x0	R/W
0x0249	Channel map fast detect lower threshold LSB	[7:0]	Fast detect lower threshold[7:0]		LSBs of fast detect lower threshold. Eight LSBs of the programmable 13-bit lower threshold that is compared to the fine ADC magnitude	0x0	R/W
0x024A	Channel map fast detect lower threshold MSB	[7:5]	Reserved		Reserved.	0x0	R
		[4:0]	Fast detect lower threshold[12:8]		LSBs of fast detect lower threshold. Eight LSBs of the programmable 13-bit lower threshold that is compared to the fine ADC magnitude	0x0	R/W
0x024B	Channel map fast detect dwell time LSB	[7:0]	Fast detect dwell time[7:0]		LSBs of fast detect dwell time counter target. This target is a load value for a 16-bit counter that determines how long the ADC data must remain below the lower threshold before the FD_x pins are reset to 0	0x0	R/W
0x024C	Channel map fast detect dwell time MSB	[7:0]	Fast detect dwell time[15:8]		LSBs of fast detect dwell time counter target. This target is a load value for a 16-bit counter that determines how long the ADC data must remain below the lower threshold before the FDD_x pins are reset to 0.	0x0	R/W
0x026F	Pair map signal monitor sync control	[7:2]	Reserved		Reserved.	0x0	R
		1	Reserved		Reserved.	0x0	R/W
		0	Signal monitor synchronization mode	0 1	Synchronization disabled. Only the next valid edge of the SYSREF± pin is used to synchronize the signal monitor block. Subsequent edges of the SYSREF± pin are ignored. After the next SYSREF± is received, this bit is cleared. Note that the SYSREF± input pin must be enabled to synchronize the signal monitor blocks.	0x0	R/W
0x0270	Channel map signal monitor control	[7:2]	Reserved		Reserved.	0x0	R
		1	Peak detector	0 1	Peak detector disabled. Peak detector enabled.	0x0	R/W
		0	Reserved		Reserved.	0x0	R
0x0271	Channel map Signal Monitor Period 0	[7:0]	Signal monitor period[7:0]		This 24-bit value sets the number of output clock cycles over which the signal monitor performs its operation. Bit 0 is ignored.	0x80	R/W
0x0272	Channel map Signal Monitor Period 1	[7:0]	Signal monitor period[15:8]		This 24-bit value sets the number of output clock cycles over which the signal monitor performs its operation. Bit 0 is ignored.	0x0	R/W
0x0273	Channel map Signal Monitor Period 2	[7:0]	Signal monitor period[23:16]		This 24-bit value sets the number of output clock cycles over which the signal monitor performs its operation. Bit 0 is ignored.	0x0	R/W

Address	Name	Bits	Bit Name	Settings	Description	Reset	Access
0x0274	Channel map signal monitor status control	[7:5]	Reserved		Reserved.	0x0	R
		4	Result update	1	Status update based on Bits[2:0] (self clearing).	0x0	R/W
		3	Reserved		Reserved.	0x0	R
		[2:0]	Result selection	001	Peak detector placed on status readback signals.	0x1	R/W
0x0275	Channel map Signal Monitor Status 0	[7:0]	Signal monitor result[7:0]		Signal monitor status result. This 20-bit value contains the status result calculated by the signal monitor block. The content is dependent on the Register 0x0274, Bits[2:0] bit settings.	0x0	R
0x0276	Channel map Signal Monitor Status 1	[7:0]	Signal monitor result[15:8]		Signal monitor status result. This 20-bit value contains the status result calculated by the signal monitor block. The content is dependent on the Register 0x0274, Bits[2:0] bit settings.	0x0	R
0x0277	Channel map Signal Monitor Status 2	[7:4]	Reserved		Reserved.	0x0	R
		[3:0]	Signal monitor result[19:16]		Signal monitor status result. This 20-bit value contains the status result calculated by the signal monitor block. The content is dependent on the Register 0x0274, Bits[2:0] bit settings.	0x0	R
0x0278	Channel map signal monitor status frame counter	[7:0]	Period count result[7:0]		Signal monitor frame counter status bits. The frame counter increments whenever the period counter expires.	0x0	R
0x0279	Channel map signal monitor serial framer control	[7:2]	Reserved		Reserved.	0x0	R
		1	Reserved		Reserved.	0x0	R/W
		0	Signal monitor SPORT over JESD204B enable	0 1	Disabled. Enabled.	0x0	R/W
0x027A	Channel map signal monitor serial framer input selection	[7:6]	Reserved		Reserved.	0x0	R
		[5:0]	Signal monitor SPORT over JESD204B peak detector enable	1	Peak detector enabled.	0x2	R/W

Address	Name	Bits	Bit Name	Settings	Description	Reset	Access
0x0300	Pair map DDC sync control	[7:6]	Reserved		Reserved.	0x0	R/W
		5	Reserved		Reserved.	0x0	R
		4	DDC NCO soft reset	0 1	This bit can be used to synchronize all the NCOs inside the DDC blocks. Normal operation. DDC held in reset.	0x0	R/W
		[3:2]	Reserved		Reserved.	0x0	R
		1	DDC next sync	0 1	The SYSREF± pin must be an integer multiple of the NCO frequency for this function to operate correctly in continuous mode. Continuous mode. Only the next valid edge of the SYSREF± pin is used to synchronize the NCO in the DDC block. Subsequent edges of the SYSREF± pin are ignored. After the next SYSREF± is found, the DDC synchronization enable bit is cleared.	0x0	R/W
		0	DDC synchronization mode	0 1	The SYSREF± input pin must be enabled to synchronize the DDCs. Synchronization disabled. If the DDC next sync bit = 1, only the next valid edge of the SYSREF± pin is used to synchronize the NCO in the DDC block. Subsequent edges of the SYSREF± pin are ignored. After the next SYSREF± is received, this bit is cleared.	0x0	R/W
0x0310	Pair map DDC 0 control	7	DDC 0 mixer select	0 1	Real mixer (I and Q inputs must be from the same real channel). Complex mixer (I and Q must be from separate real and imaginary quadrature ADC receive channels— analog demodulator).	0x0	R/W
		6	DDC 0 gain select	0 1	Gain can be used to compensate for the 6 dB loss associated with mixing an input signal down to baseband and filtering out its negative component. 0 dB gain. 6 dB gain (multiply by 2).	0x0	R/W
		[5:4]	DDC 0 IF mode	00 01 10 11	Variable IF mode. 0 Hz IF mode. f _s /4 Hz IF mode. Test mode.	0x0	R/W
		3	DDC 0 complex to real enable	0 1	Complex (I and Q) outputs contain valid data. Real (I) output only. Complex to real enabled. Uses extra f _s /4 mixing to convert to real.	0x0	R/W
		2	Reserved		Reserved.	0x0	R

Address	Name	Bits	Bit Name	Settings	Description	Reset	Access
		[1:0]	DDC 0 decimation rate select	11 00 01 10 11 00 01 10 11 00 01 10	Decimation filter selection. Complex outputs (complex to real disabled): HB1 filter selection (decimate by 2). HB2 + HB1 filter selection (decimate by 4). HB3 + HB2 + HB1 filter selection (decimate by 8). HB4 + HB3 + HB2 + HB1 filter selection (decimate by 16). Real outputs (complex to real enabled): HB1 filter selection (decimate by 1). HB2 + HB1 filter selection (decimate by 2). HB3 + HB2 + HB1 filter selection (decimate by 4). HB4 + HB3 + HB2 + HB1 filter selection (decimate by 8). HB1 filter selection: decimate by 1 or 2. HB2 + HB1 filter selection (decimate by 2 or 4). HB3 + HB2 + HB1 filter selection (decimate by 4 or 8). HB4 + HB3 + HB2 + HB1 filter selection (decimate by 8 or 16)	0x0	R/W
0x0311	Pair map DDC 0 input select	[7:3]	Reserved		Reserved.	0x0	R
		2	DDC 0 Q input select	0	Channel A.	0x0	R/W
				1	Channel B.		
		1	Reserved	0	Channel A.	0x0	R/W
1	Channel B.						
0	DDC 0 I input select	0	Channel A.	1	Channel B.	0x0	R/W
0x0314	Pair map DDC 0 Phase Increment 0	[7:0]	DDC 0 NCO frequency value, twos complement[7:0]		NCO phase increment value; twos complement phase increment value for the NCO. Complex mixing frequency = $(\text{DDC_phase_increment} \times f_s)/2^{48}$.	0x0	R/W
0x0315	Pair map DDC 0 Phase Increment 1	[7:0]	DDC 0 NCO frequency value, twos complement[15:8]		NCO phase increment value; twos complement phase increment value for the NCO. Complex mixing frequency = $(\text{DDC_PHASE_INC} \times f_s)/2^{48}$.	0x0	R/W
0x0316	Pair map DDC 0 Phase Increment 2	[7:0]	DDC 0 NCO frequency value, twos complement[23:16]		NCO phase increment value; twos complement phase increment value for the NCO. Complex mixing frequency = $(\text{DDC_PHASE_INC} \times f_s)/2^{48}$.	0x0	R/W
0x0317	Pair map DDC 0 Phase Increment 3	[7:0]	DDC 0 NCO frequency value, twos complement[31:24]		NCO phase increment value; twos complement phase increment value for the NCO. Complex mixing frequency = $(\text{DDC_PHASE_INC} \times f_s)/2^{48}$.	0x0	R/W
0x0318	Pair map DDC 0 Phase Increment 4	[7:0]	DDC 0 NCO frequency value, twos complement[39:32]		NCO phase increment value; twos complement phase increment value for the NCO. Complex mixing frequency = $(\text{DDC_PHASE_INC} \times f_s)/2^{48}$.	0x0	R/W
0x031A	Pair map DDC 0 Phase Increment 5	[7:0]	DDC 0 NCO frequency value, twos complement[47:40]		NCO phase increment value; twos complement phase increment value for the NCO. Complex mixing frequency = $(\text{DDC_PHASE_INC} \times f_s)/2^{48}$.	0x0	R/W
0x031D	Pair map DDC 0 Phase Offset 0	[7:0]	DDC 0 NCO phase value, twos complement[7:0]		Twos complement phase offset value for the NCO.	0x0	R/W

Address	Name	Bits	Bit Name	Settings	Description	Reset	Access
0x031E	Pair map DDC 0 Phase Offset 1	[7:0]	DDC 0 NCO phase value, twos complement[15:8]		Twos complement phase offset value for the NCO.	0x0	R/W
0x031F	Pair map DDC 0 Phase Offset 2	[7:0]	DDC 0 NCO phase value, twos complement[23:16]		Twos complement phase offset value for the NCO.	0x0	R/W
0x0320	Pair map DDC 0 Phase Offset 3	[7:0]	DDC 0 NCO phase value, twos complement[31:24]		Twos complement phase offset value for the NCO.	0x0	R/W
0x0321	Pair Map DDC 0 Phase Offset 4	[7:0]	DDC 0 NCO phase value, twos complement[39:32]		Twos complement phase offset value for the NCO.	0x0	R/W
0x0322	Pair map DDC 0 Phase Offset 5	[7:0]	DDC 0 NCO phase value, twos complement[47:40]		Twos complement phase offset value for the NCO.	0x0	R/W
0x0327	Pair map DDC 0 test enable	[7:3]	Reserved		Reserved.	0x0	R
		2	DDC 0 Q output test mode enable	0 1	Q samples always use the Test Mode B/ Test Mode D block. Test mode disabled. Test mode enabled.	0x0	R/W
		1	Reserved		Reserved.	0x0	R
		0	DDC 0 I output test mode enable	0 1	I Samples always use Test Mode A/ Test Mode C block. Test mode disabled. Test mode enabled.	0x0	R/W
0x0330	Pair map DDC 1 control	7	DDC 1 mixer select	0	Real mixer (I and Q inputs must be from the same real channel).	0x0	R/W
				1	Complex mixer (I and Q must be from separate, real and imaginary quadrature ADC receive channels— <i>analog</i> demodulator).		
		6	DDC 1 gain select	0	Gain can be used to compensate for the 6 dB loss associated with mixing an input signal down to baseband and filtering out its negative component. 0 dB gain.	0x0	R/W
				1	6 dB gain (multiply by 2).		
		[5:4]	DDC 1 IF mode	00 01 10 11	Variable IF mode. 0 Hz IF mode. $f_s/4$ Hz IF mode. Test mode.	0x0	R/W
3	DDC 1 complex to real enable	0 1	Complex (I and Q) outputs contain valid data. Real (I) output only. Complex to real enabled. Uses extra $f_s/4$ mixing to convert to real.	0x0	R/W		
2	Reserved		Reserved.	0x0	R		

Address	Name	Bits	Bit Name	Settings	Description	Reset	Access
		[1:0]	DDC 1 decimation rate select	11 00 01 10 11 00 01 10 11 00 01 10	Decimation filter selection. Complex outputs (complex to real disabled): HB1 filter selection (decimate by 2). HB2 + HB1 filter selection (decimate by 4). HB3 + HB2 + HB1 filter selection (decimate by 8). HB4 + HB3 + HB2 + HB1 filter selection (decimate by 16). Real outputs (complex to real enabled): HB1 filter selection (decimate by 1). HB2 + HB1 filter selection (decimate by 2). HB3 + HB2 + HB1 filter selection (decimate by 4). HB4 + HB3 + HB2 + HB1 filter selection (decimate by 8). HB1 filter selection: decimate by 1 or 2. HB2 + HB1 filter selection (decimate by 2 or 4). HB3 + HB2 + HB1 filter selection (decimate by 4 or 8). HB4 + HB3 + HB2 + HB1 filter selection (decimate by 8 or 16)	0x0	R/W
0x0331	Pair map DDC 1 input select	[7:3]	Reserved		Reserved.	0x0	R
		2	DDC 1 Q input select	0 1	Channel A. Channel B.	0x1	R/W
		1	Reserved		Reserved.	0x0	R
		0	DDC 1 I input select	0 1	Channel A. Channel B.	0x1	R/W
0x0334	Pair map DDC 1 Phase Increment 0	[7:0]	DDC 1 NCO frequency value, twos complement[7:0]		NCO phase increment value. Twos complement phase increment value for the NCO. Complex mixing frequency = $(\text{DDC phase increment} \times f_s)/2^{48}$.	0x0	R/W
0x0335	Pair map DDC 1 Phase Increment 1	[7:0]	DDC 1 NCO frequency value, twos complement[15:8]		NCO phase increment value. Twos complement phase increment value for the NCO. Complex mixing frequency = $(\text{DDC phase increment} \times f_s)/2^{48}$.	0x0	R/W
0x0336	Pair map DDC 1 Phase Increment 2	[7:0]	DDC 1 NCO frequency value, twos complement[23:16]		NCO phase increment value. Twos complement phase increment value for the NCO. Complex mixing frequency = $(\text{DDC phase increment} \times f_s)/2^{48}$.	0x0	R/W
0x0337	Pair map DDC 1 Phase Increment 3	[7:0]	DDC 1 NCO frequency value, twos complement[31:24]		NCO phase increment value. Twos complement phase increment value for the NCO. Complex mixing frequency = $(\text{DDC phase increment} \times f_s)/2^{48}$.	0x0	R/W
0x0338	Pair map DDC 1 Phase Increment 4	[7:0]	DDC 1 NCO frequency value, twos complement[39:32]		NCO phase increment value. Twos complement phase increment value for the NCO. Complex mixing frequency = $(\text{DDC phase increment} \times f_s)/2^{48}$.	0x0	R/W
0x033A	Pair map DDC 1 Phase Increment 5	[7:0]	DDC 1 NCO frequency value, twos complement[47:40]		NCO phase increment value. Twos complement phase increment value for the NCO. Complex mixing frequency = $(\text{DDC phase increment} \times f_s)/2^{48}$.	0x0	R/W
0x033D	Pair map DDC 1 Phase Offset 0	[7:0]	DDC 1 NCO phase value, twos complement[7:0]		Twos complement phase offset value for the NCO.	0x0	R/W

Address	Name	Bits	Bit Name	Settings	Description	Reset	Access
0x033E	Pair map DDC 1 Phase Offset 1	[7:0]	DDC 1 NCO phase value, twos complement[15:8]		Twos complement phase offset value for the NCO.	0x0	R/W
0x033F	Pair map DDC 1 Phase Offset 2	[7:0]	DDC 1 NCO phase value, twos complement[23:16]		Twos complement phase offset value for the NCO.	0x0	R/W
0x0340	Pair map DDC 1 Phase Offset 3	[7:0]	DDC 1 NCO phase value, twos complement[31:24]		Twos complement phase offset value for the NCO.	0x0	R/W
0x0341	Pair map DDC 1 Phase Offset 4	[7:0]	DDC 1 NCO phase value, twos complement[39:32]		Twos complement phase offset value for the NCO.	0x0	R/W
0x0342	Pair map DDC 1 Phase Offset 5	[7:0]	DDC 1 NCO phase value, twos complement[47:40]		Twos complement phase offset value for the NCO.	0x0	R/W
0x0347	Pair map DDC 1 test enable	[7:3]	Reserved		Reserved.	0x0	R
		2	DDC 1 Q output test mode enable	0 1	Q samples always use the Test Mode B/ Test Mode D block. Test mode disabled. Test mode enabled.	0x0	R/W
		1	Reserved		Reserved.	0x0	R
		0	DDC 1 I output test mode enable	0 1	I samples always use the Test Mode A/ Test Mode C block. Test mode disabled. Test mode enabled.	0x0	R/W
0x041E	Channel map NSR decimate by 2 control	7	High-pass/low-pass mode	0 1	Decimate by 2 high-pass/low-pass mode. Enable LPF. Enable HPF.	0x0	R/W
		6	Reserved		Reserved.	0x0	R
		[5:4]	Reserved		Reserved.	0x0	R/W
		[3:1]	Reserved		Reserved.	0x0	R
		0	NSR decimate by 2 enable	0 1	Decimate by 2 disabled. Decimate by 2 enabled.	0x0	R/W
0x0420	NSR mode	7	Reserved		Reserved.	0x0	R/W
		[6:4]	Reserved		Reserved.	0x0	R
		[3:1]	NSR mode	000 001	21% BW mode. 28% BW mode.	0x0	R/W
		0	Reserved		Reserved.	0x0	R
0x0422	Channel map NSR tuning	[7:6]	Reserved		Reserved.	0x0	R
		[5:0]	NSR tuning word		Noise shaped requantizer tuning frequency (see the Noise Shaping Requantizer (NSR) section for details).	0x0	R/W

Address	Name	Bits	Bit Name	Settings	Description	Reset	Access
0x0430	Pair map VDR control	7	Reserved		Reserved.	0x0	R/W
		[6:5]	Reserved		Reserved.	0x0	R
		4	Reserved		Reserved.	0x0	R/W
		[3:2]	Reserved		Reserved.	0x0	R
		1	VDR bandwidth	0 1	25% BW mode. 43% BW mode. Only available in complex mode.	0x0	R/W
0	VDR complex mode enable	0 1	Dual real mode. Ignore Bit 1. Dual complex mode. Complex input, Channel A and Channel C are I and Channel B and Channel D are Q.	0x1	R/W		
0x0434	Channel map VDR tuning frequency	[7:4]	Reserved		Reserved.	0x0	R
		[3:0]	VDR center frequency		See the Variable Dynamic Range (VDR) section for details.	0x0	R/W
0x0550	Channel map test mode control	7	User pattern selection	0 1	Continuous repeat. Single pattern.	0x0	R/W
		6	Reserved		Reserved.	0x0	R
		5	Reset PN long generation	0 1	Long PN enabled. Long PN held in reset.	0x0	R/W
		4	Reset PN short generation	0 1	Short PN enabled. Short PN held in reset.	0x0	R/W
		[3:0]	Test mode selection	0000 0001 0010 0011 0100 0101 0110 0111 1000 1111	Off—normal operation. Midscale short. Positive full scale. Negative full scale. Alternating checker board. PN sequence—long. PN sequence—short. 1/0 word toggle. User pattern test mode (used with the test mode pattern selection and the User Pattern 1 through User Pattern 4 registers) Ramp output.	0x0	R/W
0x0551	Pair map User Pattern 1 LSB	[7:0]	User Pattern 1 [7:0]		User Test Pattern 1 least significant byte	0x0	R/W
0x0552	Pair map User Pattern 1 MSB	[7:0]	User Pattern 1 [15:8]		User Test Pattern 1 most significant byte	0x0	R/W
0x0553	Pair map User Pattern 2 LSB	[7:0]	User Pattern 2 [7:0]		User Test Pattern 2 least significant byte	0x0	R/W
0x0554	Pair map User Pattern 2 MSB	[7:0]	User Pattern 2 [15:8]		User Test Pattern 2 most significant byte	0x0	R/W
0x0555	Pair map User Pattern 3 LSB	[7:0]	User Pattern 3 [7:0]		User Test Pattern 3 least significant byte	0x0	R/W
0x0556	Pair map User Pattern 3 MSB	[7:0]	User Pattern 3 [15:8]		User Test Pattern 3 most significant byte	0x0	R/W
0x0557	Pair map User Pattern 4 LSB	[7:0]	User Pattern 4 [7:0]		User Test Pattern 4 least significant byte	0x0	R/W
0x0558	Pair map User Pattern 4 MSB	[7:0]	User Pattern 4 [15:8]		User Test Pattern 4 most significant byte	0x0	R/W

Address	Name	Bits	Bit Name	Settings	Description	Reset	Access
0x0559	Pair map Output Control Mode 0	7	Reserved		Reserved.	0x0	R
		[6:4]	Converter Control Bit 1 selection	000 001 010 011 100 101 110 111	Tie low (1'b0). Overrange bit. Signal monitor bit or VDR punish Bit 0. Fast detect (FD) bit or VDR punish Bit 1. VDR high/low resolution bit. SYSREF. Reserved. Reserved.	0x0	R/W
		3	Reserved		Reserved.	0x0	R
		[2:0]	Converter Control Bit 0 selection	000 001 010 011 100 101	Tie low (1'b0) Overrange bit. Signal monitor or VDR punish Bit 0. Fast detect (FD) bit or VDR punish Bit 1. VDR high/low resolution bit. SYSREF.	0x0	R/W
0x055A	Pair Map Output Control Mode 1	[7:3]	Reserved		Reserved.	0x0	R
		[2:0]	Converter control Bit 2 selection	000 001 010 011 100 101 110 111	Tie low (1'b0). Overrange bit. Signal monitor bit or VDR punish Bit 0. Fast detect (FD) bit or VDR punish Bit 1. VDR high/low resolution bit. SYSREF. Reserved. Reserved.	0x1	R/W
0x0561	Pair map output sample mode	[7:3]	Reserved		Reserved.	0x0	R
		2	Sample invert	0 1	ADC sample data is not inverted. ADC sample data is inverted.	0x0	R/W
		[1:0]	Data format select	00 01	Offset binary. Twos complement (default).	0x1	R/W
0x0564	Pair map output channel select	[7:2]	Reserved		Reserved.	0x0	R
		1	Reserved		Reserved.	0x0	R/W
		0	Converter channel swap control	0 1	Normal channel ordering. Channel swap enabled.	0x0	R/W
0x056E	JESD204B map PLL control	[7:4]	JESD204B lane rate control	0000 0001 0011 0101	Lane rate = 6.75 to 13.5 Gbps. Lane rate = 3.375 Gbps to 6.75 Gbps. Lane rate = 13.5 to 15 Gbps. Lane rate = 1.6875 Gbps to 3.375 Gbps.	0x0	R/W
		[3:0]	Reserved		Reserved.	0x0	R
0x056F	JESD204B map PLL status	7	PLL lock status	0 1	Not locked. Locked.	0x0	R
		[6:4]	Reserved		Reserved.	0x0	R
		3	Reserved		Reserved.	0x0	R
		[2:0]	Reserved		Reserved.	0x0	R

Address	Name	Bits	Bit Name	Settings	Description	Reset	Access
0x0570	JESD204B map JTX quick configuration	[7:6]	Quick Configuration L	0 1	Number of lanes (L) = $2^{\text{Register}0x0570, \text{Bits}[7:6]}$ L = 1. L = 2.	0x1	R/W
		[5:3]	Quick Configuration M	0 1 10	Number of converters (M) = $2^{\text{Register}0x0570, \text{Bits}[5:3]}$ M = 1. M = 2. M = 4.	0x1	R/W
		[2:0]	Quick Configuration F	0 1 10 11	Number of octets/frame (F) = $2^{\text{Register}0x0570, \text{Bits}[2:0]}$ F = 1. F = 2. F = 4. F = 8.	0x1	R/W
0x0571	JESD204B map JTX Link Control 1	7	Standby mode	0 1	Standby mode forces zeros for all converter samples. Standby mode forces code group synchronization (K28.5 characters).	0x0	R/W
		6	Tail bit (t) PN	0 1	Disable. Enable.	0x0	R/W
		5	Long transport layer test	0 1	JESD204B test samples disabled. JESD204B test samples enabled. The long transport layer test sample sequence (as specified in JESD204B Section 5.1.6.3) sent on all link lanes.	0x0	R/W
		4	Lane synchronization	0 1	Disable FACL uses /K28.7/. Enable FACL uses /K28.3/ and /K28.7/.	0x1	R/W
		[3:2]	ILAS sequence mode	00 01 11	Initial lane alignment sequence disabled (see JESD204B Section 5.3.3.5). Initial lane alignment sequence enabled (see JESD204B Section 5.3.3.5). Initial lane alignment sequence always on test mode. JESD204B data link layer test mode where repeated lane alignment sequence (as specified in JESD204B, Section 5.3.3.8.2) sent on all lanes.	0x1	R/W
		1	FACL	0 1	Frame alignment character insertion enabled (JESD204B, Section 5.3.3.4). Frame alignment character insertion disabled; for debug only (JESD204B, Section 5.3.3.4)	0x0	R/W
		0	Link control	0 1	JESD204B serial transmit link enabled. Transmission of the /K28.5/ characters for code group synchronization is controlled by the SYNCINB±x signal pin. JESD204B serial transmit link powered down (held in reset and clock gated).	0x0	R/W

Address	Name	Bits	Bit Name	Settings	Description	Reset	Access
0x0572	JESD204B map JTX Link Control 2	[7:6]	SYNCINB±AB/ SYNCINB±CD pin control	00	Normal mode.	0x0	R/W
				10	Ignore SYNCINB±AB/SYNCINB±CD (force CGS).		
				11	Ignore SYNCINB±AB/SYNCINB±CD (force ILAS/user data).		
		5	SYNCINB±AB/ SYNCINB±CD pin invert	0	SYNCINB±AB/SYNCINB±CD pin not inverted.	0x0	R/W
				1	SYNCINB±AB/SYNCINB±CD pin inverted.		
		4	SYNCINB±AB/ SYNCINB±CD pin type	0	LVDS differential pair SYNC signal input.	0x0	R/W
				1	CMOS single-ended SYNC signal input.		
		3	Reserved		Reserved.	0x0	R
2	8-bit/10-bit bypass	0	8-bit/10-bit enabled.	0x0	R/W		
		1	8-bit/10-bit bypassed (the most significant two bits are 0).				
1	8-bit/10-bit bit invert	0	Normal.	0x0	R/W		
		1	Invert a b c d e f g h i j symbols.				
0	Reserved		Reserved.	0x0	R/W		
0x0573	JESD204B map JTX Link Control 3	[7:6]	Checksum mode	00	Checksum is the sum of all the 8-bit registers in the link configuration table.	0x0	R/W
				01	Checksum is the sum of all individual link configuration fields (LSB aligned).		
				10	Checksum is disabled (set to 0). For test purposes only.		
				11	Unused.		
		[5:4]	Test injection point	0	N' sample input.	0x0	R/W
				1	10-bit data at 8-bit/10-bit output (for PHY testing).		
				10	8-bit data at scrambler input.		
		[3:0]	JESD204B test mode patterns	0	Normal operation (test mode disabled).	0x0	R/W
				1	Alternating checkerboard.		
				10	1/0 word toggle.		
11	31-bit PN sequence: $x^{31} + x^{28} + 1$.						
100	23-bit PN sequence: $x^{23} + x^{18} + 1$.						
101	15-bit PN sequence: $x^{15} + x^{14} + 1$.						
110	9-bit PN sequence: $x^9 + x^5 + 1$.						
111	7-bit PN sequence: $x^7 + x^6 + 1$.						
1000	Ramp output.						
1110	Continuous/repeat user test.						
1111	Single user test.						

Address	Name	Bits	Bit Name	Settings	Description	Reset	Access
0x0574	JESD204B map JTX Link Control 4	[7:4]	ILAS delay	0	Transmit ILAS on first LMFC after SYNCINB±x is deasserted.	0x0	R/W
				1	Transmit ILAS on second LMFC after SYNCINB± is deasserted.		
				10	Transmit ILAS on third LMFC after SYNCINB±x is deasserted.		
				11	Transmit ILAS on fourth LMFC after SYNCINB± is deasserted.		
				100	Transmit ILAS on fifth LMFC after SYNCINB±x is deasserted.		
				101	Transmit ILAS on sixth LMFC after SYNCINB±x is deasserted.		
				110	Transmit ILAS on seventh LMFC after SYNCINB±x is deasserted.		
				111	Transmit ILAS on eighth LMFC after SYNCINB±x is deasserted.		
				1000	Transmit ILAS on ninth LMFC after SYNCINB±x is deasserted.		
				1001	Transmit ILAS on 10th LMFC after SYNCINB±x is deasserted.		
				1010	Transmit ILAS on 11th LMFC after SYNCINB±x is deasserted.		
				1011	Transmit ILAS on 12th LMFC after SYNCINB±x is deasserted.		
				1100	Transmit ILAS on 13th LMFC after SYNCINB±x is deasserted.		
				1101	Transmit ILAS on 14th LMFC after SYNCINB±x is deasserted.		
				1110	Transmit ILAS on 15th LMFC after SYNCINB±x is deasserted.		
				1111	Transmit ILAS on 16th LMFC after SYNCINB±x is deasserted.		
3	Reserved		Reserved.	0x0	R		
[2:0]	Link layer test mode				0x0	R/W	
			000	Normal operation (link layer test mode disabled).			
			001	Continuous sequence of /D21.5/ characters.			
			010	Reserved.			
			011	Reserved.			
			100	Modified RPAT test sequence.			
			101	JSPAT test sequence.			
			110	JTSPAT test sequence.			
			111	Reserved.			
0x0578	JESD204B map JTX LMFC offset	[7:5]	Reserved		Reserved.	0x0	R
		[4:0]	LMFC phase offset value		LMFC phase offset value; reset value for LMFC phase counter when SYSREF± is asserted. Used for deterministic delay applications.	0x0	R/W

Address	Name	Bits	Bit Name	Settings	Description	Reset	Access
0x0580	JESD204B map JTX DID configuration	[7:0]	JESD204B Tx DID value		JESD204B serial device identification (DID) number.	0x0	R/W
0x0581	JESD204B map JTX BID configuration	[7:4]	Reserved		Reserved.	0x0	R
		[3:0]	JESD204B Tx BID value		JESD204B serial bank identification (BID) number (extension to DID).	0x0	R/W
0x0583	JESD204B map JTX LID0 configuration	[7:5]	Reserved		Reserved.	0x0	R
		[4:0]	Lane 0 LID value		JESD204B serial lane identification (LID) number for Lane 0.	0x0	R/W
0x0585	JESD204B map JTX LID1 configuration	[7:5]	Reserved		Reserved.	0x0	R
		[4:0]	Lane 1 LID Value		JESD204B serial lane identification (LID) number for Lane 1.	0x2	R/W
0x058B	JESD204B map JTX SCR L configuration	7	JESD204B scrambling (SCR)	0	JESD204B scrambler disabled. SCR = 0. JESD204B scrambler enabled. SCR = 1.	0x1	R/W
				1			
		[6:5]	Reserved		Reserved.	0x0	R
0x058B	JESD204B map JTX SCR L configuration	[4:0]	JESD204B lanes (L)	0x0 0x1	One lane per link (L = 1). Two lanes per link (L = 2).	0x1	R
0x058C	JESD204B map JTX F configuration	[7:0]	Number of octets per frame (F)		Number of octets per frame. F = Register 0x058C, Bits[7:0] + 1.	0x1	R
0x058D	JESD204B map JTX K configuration	[7:5]	Reserved		Reserved.	0x0	R
		[4:0]	Number of frames per multiframe (K)		JESD204B number of frames per multi-frame (K = Register 0x058D, Bits[4:0] + 1). Only values where F × K are divisible by 4 can be used.	0x1F	R/W
				00011	K = 4.		
				00111	K = 8.		
				01100	K = 12.		
				01111	K = 16.		
				10011	K = 20.		
				10111	K = 24.		
11011	K = 28.						
11111	K = 32.						
0x058E	JESD204B Map JTX M configuration	[7:0]	Number of converters per link	00000000	Link connected to one virtual converter (M = 1).	0x1	R
				00000001	Link connected to two virtual converters (M = 2).		
				00000011	Link connected to four virtual converters (M = 4).		
0x058F	JESD204B map JTX CS N configuration	[7:6]	Number of control bits (CS) per sample	0	No control bits (CS = 0).	0x0	R/W
				1	One control bit (CS = 1), Control Bit 2 only.		
				10	Two control bits (CS = 2), Control Bit 2 and Control Bit 1 only.		
				11	Three control bits (CS = 3), all control bits (Bits[2:0]).		
		5	Reserved		Reserved.	0x0	R

Address	Name	Bits	Bit Name	Settings	Description	Reset	Access
		[4:0]	ADC converter resolution (N)	00110 00111 01000 01001 01010 01011 01100 01101 01110 01111	N = 7-bit resolution. N = 8-bit resolution. N = 9-bit resolution. N = 10-bit resolution. N = 11-bit resolution. N = 12-bit resolution. N = 13-bit resolution. N = 14-bit resolution. N = 15-bit resolution. N = 16-bit resolution.	0xF	R/W
0x0590	JESD204B map JTX SCV NP configuration	[7:5]	Subclass support	000 001	Subclass 0. Subclass 1.	0x1	R/W
		[4:0]	ADC number of bits per sample (N')	00111 01111	N' = 8. N' = 16.	0xF	R/W
0x0591	JESD204B map JTX JV S configuration	[7:5]	Reserved		Reserved.	0x1	R
		[4:0]	Samples per converter frame cycle (S)		Samples per converter frame cycle (S = Register 0x0591, Bits[4:0] + 1).	0x0	R
0x0592	JESD204B map JTX HD CF configuration	7	HD value	0 1	High density format disabled. High density format enabled.	0x0	R
		[6:5]	Reserved		Reserved.	0x0	R
		[4:0]	Control words per frame clock cycle per link (CF)		Number of control words per frame clock cycle per link (CF = Register 0x0592, Bits[4:0]).	0x0	R
0x05A0	JESD204B map JTX Checksum 0 configuration	[7:0]	Checksum 0 checksum value for SERDOUTAB0±/ SERDOUTCD0±		Serial checksum value for Lane 0, automatically calculated for each lane. Sum (all link configuration parameters for Lane 0) mod 256.	0xC3	R
0x05A1	JESD204B map JTX Checksum 1 configuration	[7:0]	Checksum 1 checksum value for SERDOUTAB1±/ SERDOUTCD1±		Serial checksum value for Lane 1, automatically calculated for each lane. Sum (all link configuration parameters for Lane 1) mod 256.	0xC4	R
0x05B0	SERDOUTx0±/ SERDOUTx1± power-down	[7:3]	Reserved		Reserved.	0x1F	R/W
		2	SERDOUTx1± power-down		Physical Lane 1 force power-down.	0x0	R/W
		1	Reserved		Reserved.	0x1	R/W
		0	SERDOUTx0± power-down		Physical Lane 0 force power-down.	0x0	R/W
0x05B2	JESD204B map JTX Lane Assignment 1	7	Reserved		Reserved.	0x0	R
		[6:4]	Reserved		Reserved.	0x0	R/W
		3	Reserved		Reserved.	0x0	R
		[2:0]	SERDOUTAB0±/ SERDOUTCD0± lane assignment	0 1	Logical Lane 0 (default). Logical Lane 1.	0x0	R/W
0x05B3	JESD204B map JTX Lane Assignment 2	7	Reserved		Reserved.	0x0	R
		[6:4]	Reserved		Reserved.	0x1	R/W
		3	Reserved		Reserved.	0x0	R
		[2:0]	SERDOUTAB1±/ SERDOUTCD1± lane assignment	0 1	Logical Lane 0. Logical Lane 1 (default).	0x1	R/W

Address	Name	Bits	Bit Name	Settings	Description	Reset	Access
0x05C0	JESD204B map JESD204B serializer drive adjust	[7:3]	Reserved		Reserved.	0x0	R
		[2:0]	Swing voltage SERDOUTx0±	0 1	1.0 × DRVDD1 (differential). 0.850 × DRVDD1 (differential).	0x1	R/W
0x05C1	JESD204B map JESD204B serializer drive adjust	[7:3]	Reserved		Reserved.	0x0	R
		[2:0]	Swing voltage SERDOUTx1±	0	1.0 × DRVDD1 (differential).	0x1	R/W
0x05C4	SERDOUTx0± pre-emphasis select	7	Post tab polarity	0	Post tab polarity. Normal.	0x0	R/W
				1	Inverted.		
		[6:4]	Sets post tap level for SERDOUTx0±	0	0 dB.	0x0	R/W
				1	3 dB.		
				10	6 dB.		
				11	9 dB.		
100	12 dB.						
101	Not valid.						
110	Not valid.						
111	Not valid.						
3	Pretab polarity	0	Pretab polarity. Normal.	0x0	R/W		
		1	Inverted.				
[2:0]	Sets pretab level	0	0 dB.	0x0	R/W		
		1	3 dB.				
		10	6 dB.				
		11	9 dB.				
		100	12 dB.				
		101	Not valid.				
110	Not valid.						
111	Not valid.						
0x05C6	SERDOUTx1± pre-emphasis select	7	Post tap enable	0	Post tab polarity. Normal.	0x0	R/W
				1	Inverted.		
		[6:4]	Sets post tap level for SERDOUTx1±	0	0 dB.	0x0	R/W
				1	3 dB.		
				10	6 dB.		
				11	9 dB.		
100	12 dB.						
101	Not valid.						
110	Not valid.						
111	Not valid.						
3	Pretab polarity	0	This bit sets the pretab polarity. Normal.	0x0	R/W		
		1	Inverted.				

Address	Name	Bits	Bit Name	Settings	Description	Reset	Access
		[2:0]	Sets pretab level	0 1 10 11 100 101 110 111	These bits set the pretab level. 0 dB. 3 dB. 6 dB. 9 dB. 12 dB. Not valid. Not valid. Not valid.	0x0	R/W
0x0922	Large dither control	[7:0]	Large dither control	1110000 1110001	Enables/disables the large dither control. Enable. Disable.	0x70	R/W
0x1222	PLL calibration	[7:0]	PLL calibration	0x00 0x04	PLL calibration. Normal operation. PLL calibration	0x0	R/W
0x1228	JESD204B start-up circuit reset	[7:0]	JESD204B start-up circuit reset	0x0F 0x4F	JESD204B start-up circuit reset. Normal operation. Start-up circuit reset.	0xF	R/W
0x1262	PLL loss of lock control		PLL loss of lock control	0x00 0x08	PLL loss of lock control. Normal operation. Clear loss of lock.	0x0	R/W
0x18A6	Pair map VREF control	[7:5]	Reserved		Reserved.	0x0	R
		4	Reserved		Reserved.	0x0	R/W
		[3:1]	Reserved		Reserved.	0x0	R
		0	VREF control	0 1	Internal reference. External reference.	0x0	R/W
0x1908	Channel map analog input control	[7:6]	Reserved		Reserved.	0x0	R
		[5:4]	Reserved		Reserved.	0x0	R/W
		3	Reserved		Reserved.	0x0	R
		2	Analog input dc coupling control	0 1	Analog input dc coupling control. AC coupling. DC coupling.	0x0	R/W
		1	Reserved		Reserved.	0x0	R
		0	Reserved		Reserved.	0x0	R/W
0x1910	Channel map input full-scale range	[7:4]	Reserved		Reserved.	0x0	R
		[3:0]	Input full-scale control	0000 1010 1011 1100 1101 1110 1111	Input full-scale control 2.16 V p-p. 1.44 V p-p. 1.56 V p-p. 1.68 V p-p. 1.80 V p-p. 1.92 V p-p. 2.04 V p-p.	0xD	R/W

Address	Name	Bits	Bit Name	Settings	Description	Reset	Access
0x1A4C	Channel map Buffer Control 1	[7:6]	Reserved		Reserved.	0x0	R
		[5:0]	Buffer Control 1		Buffer Control 1.	0xC	R/W
				00110	120 μ A.		
				01000	160 μ A.		
				01010	200 μ A.		
				01100	240 μ A.		
				01110	280 μ A.		
				10000	320 μ A.		
				10010	360 μ A.		
10100	400 μ A.						
10110	440 μ A.						
0x1A4D	Channel map Buffer Control 2	[7:6]	Reserved		Reserved.	0x0	R
		[5:0]	Buffer Control 2		Buffer Control 2.	0xC	R/W
				00110	120 μ A.		
				01000	160 μ A.		
				01010	200 μ A.		
				01100	240 μ A.		
				01110	280 μ A.		
				10000	320 μ A.		
				10010	360 μ A.		
10100	400 μ A.						
10110	440 μ A.						
0x18E0	External VCM Buffer Control 1	[7:0]	External VCM Buffer Control 1		See the Input Common Mode section for details.	0x0	R/W
0x18E1	External VCM Buffer Control 2	[7:0]	External VCM Buffer Control 2		See the Input Common Mode section for details.	0x0	R/W
0x18E2	External VCM Buffer Control 3	[7:0]	External VCM Buffer Control 3		See the Input Common Mode section for details.	0x0	R/W
0x18E3	External VCM buffer control	7	Reserved		Reserved.	0x0	R/W
		6	External VCM buffer	1 0	External VCM buffer. Enable. Disable.	0x0	R/W
		[5:0]	External VCM buffer current setting		See the Input Common Mode section for details.	0x0	R/W
0x18E6	Temperature diode export	[7:1]	Reserved		Reserved.	0x0	R/W
		0	Temperature diode export	1 0	Temperature diode export. Enable. Disable.	0x0	R/W

APPLICATIONS INFORMATION

POWER SUPPLY RECOMMENDATIONS

The AD6684 must be powered by the following seven supplies: AVDD1 = AVDD1_SR = 0.975 V, AVDD2 = 1.8 V, AVDD3 = 2.5 V, DVDD = 0.975 V, DRVDD1 = 0.975 V, and SPIVDD = 1.8 V. For applications requiring an optimal high power efficiency and low noise performance, it is recommended that the [ADP5054](#) quad switching regulator be used to convert the 6.0 V or 12 V input rails to intermediate rails (1.3 V, 2.4 V, and 3.0 V). These intermediate rails are then post regulated by very low noise, low dropout (LDO) regulators ([ADP1762](#), [ADP7159](#), [ADP151](#), and [ADP7118](#)).

Figure 105 shows the recommended power supply scheme for the AD6684.

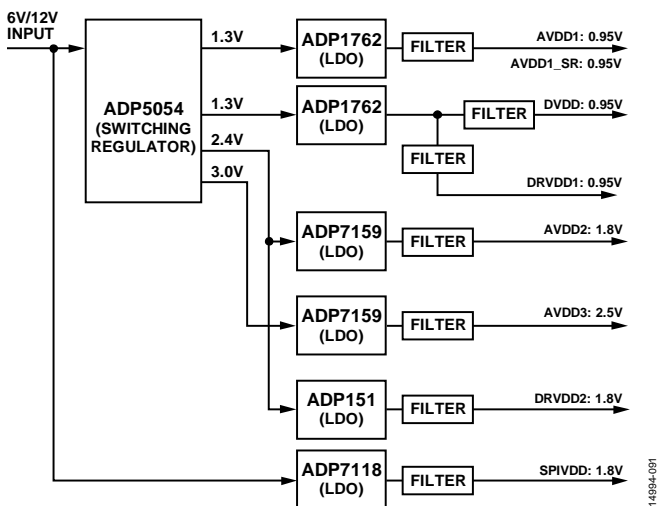

Figure 105. High Efficiency, Low Noise Power Solution for the AD6684

It is not necessary to split all of these power domains in all cases. The recommended solution shown in Figure 105 provides the lowest noise, highest efficiency power delivery system for the AD6684. If only one 0.975 V supply is available, route to AVDD1 first and then tap it off and isolate it with a ferrite bead or a filter choke, preceded by decoupling capacitors for AVDD1_SR, DVDD, and DRVDD, in that order. The user can employ several different decoupling capacitors to cover both high and low frequencies. These capacitors must be located close to the point of entry at the PCB level and close to the devices, with minimal trace lengths.

EXPOSED PAD THERMAL HEAT SLUG RECOMMENDATIONS

It is required that the exposed pad on the underside of the ADC be connected to AGND to achieve the best electrical and thermal performance of the AD6684. Connect an exposed continuous copper plane on the PCB to the AD6684 exposed pad, Pin 0. The copper plane must have several vias to achieve the lowest possible resistive thermal path for heat dissipation to flow through the bottom of the PCB. These vias must be solder filled or plugged. The number of vias and the fill determine the resultant θ_{JA} measured on the board (see Table 7).

See Figure 106 for a PCB layout example. For detailed information on packaging and the PCB layout of chip scale packages, see the [AN-772 Application Note, A Design and Manufacturing Guide for the Lead Frame Chip Scale Package \(LFCSP\)](#).

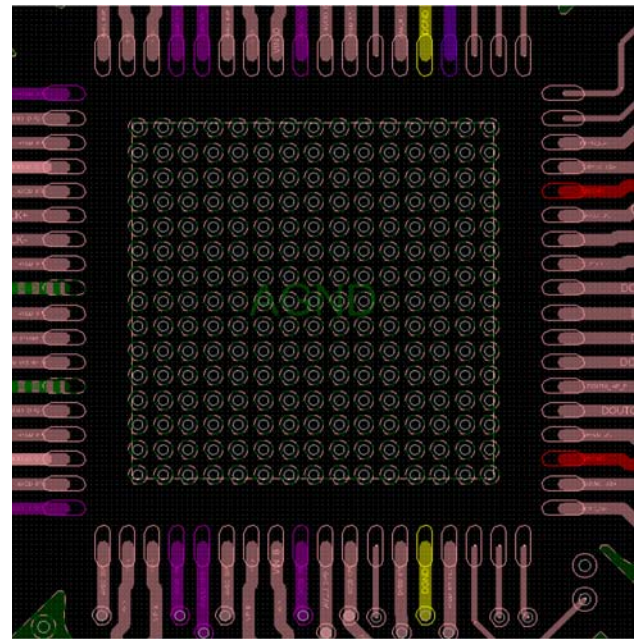

Figure 106. Recommended PCB Layout of Exposed Pad for the AD6684

AVDD1_SR (PIN 64) AND AGND_SR (PIN 63 AND PIN 67)

AVDD1_SR (Pin 64) and AGND_SR (Pin 63 and Pin 67) can be used to provide a separate power supply node to the SYSREF± circuits of the AD6684. If running in Subclass 1, the AD6684 can support periodic one-shot or gapped signals. To minimize the coupling of this supply into the AVDD1 supply node, adequate supply bypassing is needed.

OUTLINE DIMENSIONS

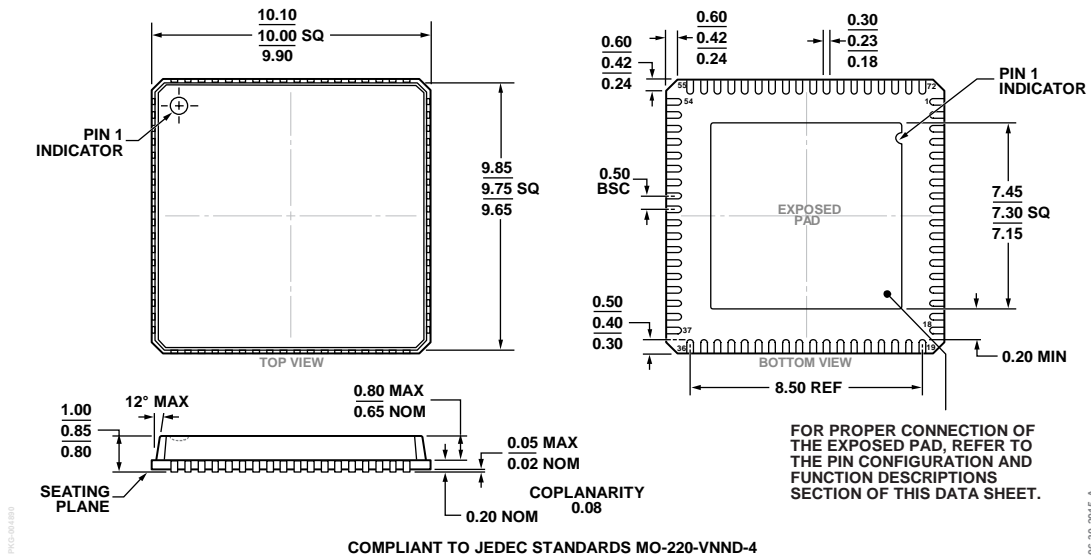

Figure 107. 72-Lead Lead Frame Chip Scale Package [LFCS]
 10 mm × 10 mm Body and 0.85 mm Package Height
 (CP-72-10)
 Dimensions shown in millimeters

ORDERING GUIDE

Model ¹	Junction Temperature Range	Package Description	Package Option
AD6684BCPZ-500	-40°C to +105°C	72-Lead Lead Frame Chip Scale Package [LFCS]	CP-72-10
AD6684BCPZRL7-500	-40°C to +105°C	72-Lead Lead Frame Chip Scale Package [LFCS]	CP-72-10
AD6684-500EBZ		Evaluation Board for AD6684	

¹ Z = RoHS Compliant Part.

Looking for pricing, stock, or lifecycle information?

Click below to explore more details on WIN SOURCE:

 [View AD6684BCPZ-500 on WIN SOURCE](#)

 [Analog Devices Inc. Information](#)

Optimize Your Supply Chain with WIN SOURCE Solutions

-  Global Sourcing Solution
-  Obsolete Management
-  Cost Control Management
-  Shortage Management
-  Alternative Solution
-  Excess Inventory Management