



**THE DATASHEET OF  
A6271KLPTR-T-1**



## DUAL-SUPPLY 2:1 SIM CARD MULTIPLEXER/TRANSLATOR WITH AUTOMATIC DETECTION AND SLOT DEDICATED DUAL LDO

Check for Samples: [TXS02326A](#)

### FEATURES

- **Level Translator**
  - VDDIO Range of 1.7-V to 3.3-V
- **Low-Dropout (LDO) Regulator**
  - 50-mA LDO Regulator With Enable
  - 1.8-V or 2.95-V Selectable Output Voltage
  - 2.3-V to 5.5-V Input Voltage Range
  - Very Low Dropout: 100 mV (Max) at 50 mA
- **Control and Communication Through I<sup>2</sup>C Interface With Baseband Processor**
- **ESD Protection Exceeds JESD 22**
  - 2500-V Human-Body Model (A114-B)
  - 6000-V Human-Body Model (A114-B) on VSIM1, SIM1CLK, SIM1I/O, SIM1RST, VSIM2, SIM2CLK, SIM2I/O, SIM2RST
  - 1000-V Charged-Device Model (C101)
- **Package**
  - 24-Pin QFN (4 mm x 4 mm)

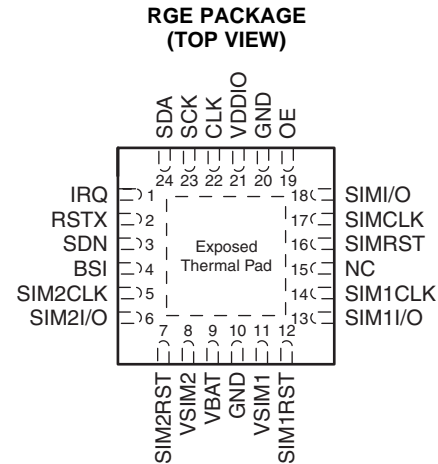

Note: The Exposed Thermal Pad must be connect to Ground.

### DESCRIPTION/ORDERING INFORMATION

The TXS02326A is a complete dual-supply standby Smart Identity Module (SIM) card solution for interfacing wireless baseband processors with two individual SIM subscriber cards to store data for mobile handset applications. It is a custom device which is used to extend a single SIM/UICC interface to support two SIMs/UICCs.

The device complies with ISO/IEC Smart-Card Interface requirements as well as GSM and 3G mobile standards. It includes a high-speed level translator capable of supporting Class-B (2.95-V) and Class-C (1.8-V) interfaces; two low-dropout (LDO) voltage regulators with output voltages that are selectable between 2.95-V Class-B and 1.8-V Class-C interfaces; an integrated "fast-mode" 400 kb/s "slave" I<sup>2</sup>C control register interface, for configuration purposes; and a 32-kHz clock input, for internal timing generation. The TXS02326A also includes a shutdown input and a comparator input that detects battery pack removal to safely power-down the two SIM cards. The shutdown input and comparator input are equipped with two programmable debounce counter (i.e. BSI input and SDN input) circuits realized by an 8 bit counter.

The voltage-level translator has two supply voltage pins. VDDIO sets the reference for the baseband interface and can be operated from 1.7-V to 3.3-V. VSIM1 and VSIM2 are programmed to either 1.8-V or 2.95-V, each supplied by an independent internal LDO regulator. The integrated LDO accepts input battery voltages from 2.3-V to 5.5-V and outputs up to 50 mA to the B-side circuitry and external Class-B or Class-C SIM card.

### ORDERING INFORMATION

For the most current package and ordering information, see the Package Option Addendum at the end of this document.



Please be aware that an important notice concerning availability, standard warranty, and use in critical applications of Texas Instruments semiconductor products and disclaimers thereto appears at the end of this data sheet.



This integrated circuit can be damaged by ESD. Texas Instruments recommends that all integrated circuits be handled with appropriate precautions. Failure to observe proper handling and installation procedures can cause damage.

ESD damage can range from subtle performance degradation to complete device failure. Precision integrated circuits may be more susceptible to damage because very small parametric changes could cause the device not to meet its published specifications.

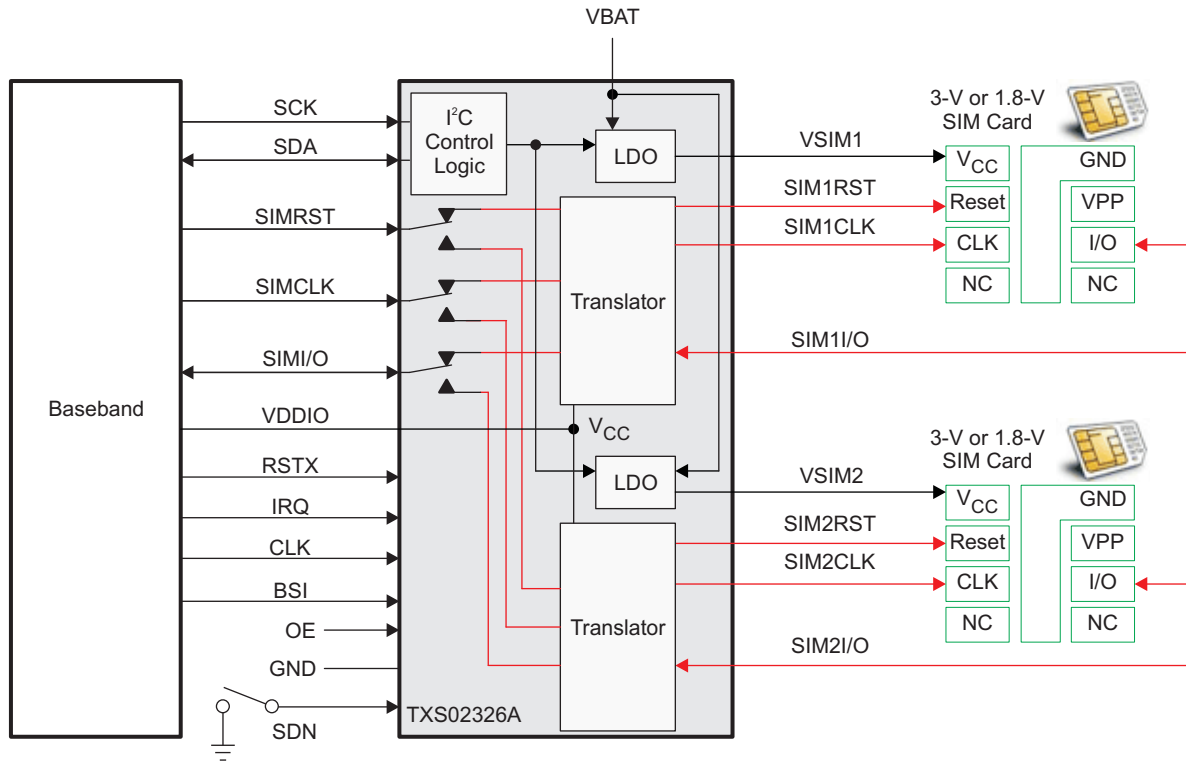

Figure 1. Interfacing With SIM Card

**TERMINAL FUNCTIONS**

NO.	NAME	TYPE <sup>(1)</sup>	POWER DOMAIN	DESCRIPTION
1	IRQ	I/O	VDDIO	Interrupt to baseband. This signal is used to set the I2C address.
2	RSTX	I	VDDIO	Active-low reset input from baseband
3	SDN	I	VDDIO	Power down SIM2; for example, from switch
4	BSI	I	VDDIO	Analog signal from battery. This input accepts input voltages up to 3 V.
5	SIM2CLK	O	VSIM2	SIM2 clock
6	SIM2I/O	I/O	VSIM2	SIM2 data
7	SIM2RST	O	VSIM2	SIM2 reset
8	VSIM2	O	VSIM2	1.8 V/2.95 V supply voltage to SIM2
9	VBAT	P	VBAT	Battery power supply
10	GND	G		Ground
11	VSIM1	O	VSIM1	1.8 V/2.95 V supply voltage to SIM1
12	SIM1RST	O	VSIM1	SIM1 reset
13	SIM1I/O	I/O	VSIM1	SIM1 data
14	SIM1CLK	O	VSIM1	SIM1 clock
15	NC			No connect
16	SIMRST	I	VDDIO	UICC/SIM reset from baseband
17	SIMCLK	I	VDDIO	UICC/SIM clock
18	SIMI/O	I/O	VDDIO	UICC/SIM data
19	OE	I	VDDIO	UICC/SIM data direction from baseband
20	GND	G		
21	VDDIO	P	VDDIO	1.8-V power supply for device operation and I/O buffers toward baseband
22	CLK	I	VDDIO	32-kHz clock
23	SCK	I	VDDIO	I <sup>2</sup> C clock
24	SDA	I/O	VDDIO	I <sup>2</sup> C data

(1) G = Ground, I = Input, O = Output, P = Power

**Table 1. Register Overview**

REGISTER BITS								COMMAND BYTE (HEX)	REGISTER	READ OR WRITE	POWER-UP DEFAULT	
B7	B6	B5	B4	B3	B2	B1	B0					
0	0	0	1	0	0	1	0	00h	Device hardware revision information	R	0001 0010	
0	0	0	0	0	0	0	0	01h	Software revision information	R	0000 0000	
SIM2 Interface Status		SIM1 Interface Status		Battery Removal Interrupt Status	Battery Status	SDN Interrupt Status	SDN Status	04h	Status Register	R	0000 0000	
SIM2 Interface Status		SIM2 Voltage Select	SIM2 LDO Enable/Disable	SIM1 Interface Status		SIM1 Voltage Select	SIM1 LDO Enable/Disable	08h	SIM Interface Control Register	R/W	0000 0000	
BSI Debounce Counter Value								0Ah	BSI Input Debounce Counter	R/W	0000 0100	
SDN Debounce Counter Value								0Bh	SDN Input Debounce Counter	R/W	0000 0100	
Reserved / Not Supported								0Ch	Reserved	R/W	0000 0000	
Clock Source Select	Clock Control (Reserved)							0Dh	External Clock Control	R/W	0000 0000	
SDN Detection Behavior control	SDN Level Detection Select	SDN Interrupt Enable/Disable	BSI Detection Behavior Control	BSI Level Detection Select	Battery Removal Interrupt Enable/Disable	OE Direction Control	OE Control Select	0Eh	Device Control Register	R/W	0000 0000	
								10h-14h	Device-specific testing	R/W	xxxx xxxx	
Reserved							SDN Pull-down Enable/Disable	SDN Pull-up Enable/Disable	15h	General purpose	R/W	0000 0000

**Table 2. Device Hardware Revision Register (00h)**

Device HW Driver Register	Bits(s)	Type (R/W)	Description
HW identification	7:0	R	This register contains the manufacturer and device ID <sup>(1)</sup> (value to be specified by the manufacturer)

(1) The manufacturer ID part of this data shall remain unchanged when the HW revision ID is updated. The manufacturer ID shall uniquely identify the manufacturer. The manufacturer ID is encoded on the MSB nibble.

**Table 3. Device Software Revision Register (01h)**

Device SW Driver Register	Bits(s)	Type (R/W)	Description
SW Driver Version	7:0	R	This register contains information about the SW driver required for this device. This information shall only be updated when changes to the device requires SW modifications. Initial register value is 00h

**Table 4. Status Register (04h)**

Status Register	Bits(s)	Type (R/W)	Description
SDN Status	0	R	SDN signal state captured at the input pin '0' SDN signal at GND '1' SDN signal at VDDIO level
SDN Interrupt	1	R	SDN interrupt status '0' No interrupt '1' Interrupt occurred, (the read operation will automatically clear this bit)
Battery Status	2	R	'0' Battery present '1' Battery not present, i.e. debounce counter expired
Battery Removal Interrupt	3	R	Battery removal interrupt status '0' No interrupt '1' Interrupt occurred, (the read operation will automatically clear this bit)
SIM1 Interface Status [1:0]	5:4 <sup>(1)</sup>	R	Status of SIM1 interface '00' Powered down with pull-downs activated '01' Isolated with pull-downs deactivated '10' Powered with pull downs activated '11' Active with pull downs deactivated
SIM2 Interface Status [1:0]	7:6 <sup>(1)</sup>	R	Status of SIM2 interface '00' Powered down with pull-downs activated '01' Isolated with pull-downs deactivated '10' Powered with pull downs activated '11' Active with pull downs deactivated

(1) The content of bits 5:4 and 7:6 reflects the value written to the state bits in the SIM Interface control register 3:2 and 7:6 respectively and the setting of the regulator bits in the SIM interface control register 0 and 4 respectively.

**Table 5. State and Status Bit Mapping**

SIM Interface Control Register (08h) SIM1 interface state bits 3:2 SIM2 interface state bits 7:6	SIM Interface Control Register (08h) SIM1 regulator control bit 0 SIM2 regulator control bit 4	SIM Status Register (04h) SIM1 status bits 5:4 SIM2 status bits 7:6	Comment
'00' Powered down state with pull-downs activated	'0' Regulator is off, regulator output is pulled down	'00' Powered down with pulldowns activated	
'00' Powered down state with pull-downs activated	'1' Regulator is powered on, regulator output pull-down is released	'10' Powered with totem pole pull-downs	
'01' Isolated state with pulldowns deactivated	'0' Regulator is off, regulator output is pulled down	'00' Powered down with pulldowns activated	The interface can only be in isolated state when the interface is powered
'01' Isolated state with pulldowns deactivated	'1' Regulator is powered on, regulator output pull-down is released	'01' Isolated with pull-downs deactivated	
'10' Not allowed	'0' Regulator is off, regulator output is pulled down	'00' Powered down with pulldowns activated	This combination shall not be used. If used the status bit coding is as specified

**Table 5. State and Status Bit Mapping (continued)**

SIM Interface Control Register (08h) SIM1 interface state bits 3:2 SIM2 interface state bits 7:6	SIM Interface Control Register (08h) SIM1 regulator control bit 0 SIM2 regulator control bit 4	SIM Status Register (04h) SIM1 status bits 5:4 SIM2 status bits 7:6	Comment
'10' Not allowed	'1' Regulator is powered on, regulator output pull-down is released	'10' Powered with pull downs activated	This combination shall not be used. If used the status bit coding is as specified
'11' Active state with pull-downs deactivated	'0' Regulator is off, regulator output is pulled down	'00' Powered down with pulldowns activated	The interface can only be active if it is powered
'11' Active state with pull-downs deactivated	'1' Regulator is powered on, regulator output pull-down is released	'11' Active with pull-downs deactivated	

**Table 6. SIM Interface Control Register (08h)<sup>(1) (2)</sup>**

Status Register	Bit(s)	Type (R/W)	Description	
SIM1 Regulator Control	0	R/W	'0' Regulator is off, regulator output is pulled down '1' Regulator is powered on, regulator output pull-down is released	
SIM1 Regulator Voltage Selection	1	R/W	'0' 1.8 V '1' 2.95 V	
SIM1 Interface State [1:0]	3:2	R/W	Status of SIM1 interface	
			'00' state is dependent on bit 0: If bit 0 = '0', then powered down state with pull-downs activated If bit 0 = '1', then isolated state with pull-downs deactivated	Pull down resistor active Totem pole pull down
			'01' Isolated state with pull-downs deactivated	Output latched at previous state driven by totem pole output
			'10' Not allowed	Not allowed
			'11' Active state with pull-downs deactivated	Outputs follow the inputs
SIM2 Regulator Control	4	R/W	'0' Regulator is off, regulator output is pulled down '1' Regulator is powered on, regulator output pull-down is released	
SIM2 Regulator Voltage Selection	5	R/W	'0' 1.8 V '1' 2.95 V	
SIM2 Interface State [1:0]	7:6	R/W	Status of SIM2 interface	
			'00' State is dependent on bit 4: If bit 4 = '0', then powered down state with pull-downs activated If bit 4 = '1', then isolated state with pull-downs deactivated	Pull down resistor active Totem pole pull down
			'01' Isolated state with pull-downs deactivated	Output latched at previous state driven by totem pole output
			'10' Not allowed	Not allowed
			'11' Active state with pull-downs deactivated	Outputs follow the inputs

(1) Reset value: 00h

(2) The state '10', on bits 3:2 and 7:6, is not prevented by HW but shall never be set by SW. State '10' means that the interface is powered with the pull-downs active, this state correspond to state '00' with the regulator being switched on. Setting the state to '10' does not have any impact on the corresponding regulator bit setting. The regulator control bits do not impact the state bits in this register. The regulator control bits however do impact the status bits in the status register.

**Table 7. Battery Presence Detection Debounce Counter (0Ah)<sup>(1)</sup> <sup>(2)</sup>**

BSI Debounce Counter	Bits(s)	Type (R/W)	Description
Debounce Counter Value [7:0]	7:0	R/W	This register contains the BSI input debounce counter value. The value 00h means that the counter is not used, i.e. no debounce.

- (1) Reset value: 04h  
 (2) Updating the register causes the counter to restart with the new value if the counter is counting when the register is updated. The new value shall take affect no later than one clock cycle (32 KHz) after the register has been updated.

**Table 8. SDN Input Debounce Counter (0Bh)<sup>(1)</sup> <sup>(2)</sup>**

SDN Debounce Counter	Bits(s)	Type (R/W)	Description
Debounce Counter Value [7:0]	7:0	R/W	This register contains the SDN input debounce counter value. The value 00h means that the counter is not used, i.e. no debounce.

- (1) Reset value: 04h  
 (2) Updating the register causes the counter to restart with the new value if the counter is counting when the register is updated. The new value shall take affect no later than one clock cycle (32 KHz) after the register has been updated.

**Table 9. External Clock Control (0Dh)<sup>(1)</sup>**

Clock Control Register	Bits(s)	Type (R/W)	Description
Clock Control	6:0	R/W	Reserved
Clock Source Select	7	R/W	'0' Internal clock source used '1' External clock source CLK (supplied on pin 22 used)

- (1) Reset value: 00h

**Table 10. Device Control Register (0Eh)<sup>(1)</sup>**

Clock Control Register	Bits(s)	Type (R/W)	Description
OE Control	0	R/W	'0' OE is not used to control the data direction on the selected SIM I/O and the base band I/O '1' OE controls the data direction, see below
OE Direction Control	1	R/W	'0' OE input = '0' data direction Base band -> SIM OE input = '1' data direction SIM -> base band '1' OE input = '0' data direction SIM -> base band OE input = '1' data direction Base band -> SIM
Battery Removal Interrupt	2	R/W	'0' Battery removal interrupt disabled '1' Battery removal detected causes interrupt on IRQ (interrupt sets b3 in the status register)
BSI Level Detection	3	R/W	BSI detection level '0' 1.2V '1' 1.65V
BSI Detection Control	4	R/W	BSI detection behavior '0' Battery not present causes automatic power down of both SIM interfaces '1' Battery not present doesn't cause automatic power down
SDN Detection Interrupt	5	R/W	'0' SDN detection interrupt disabled '1' SDN detected causes interrupt on IRQ (interrupt sets b1 in the status register)
SDN Detection Level	6	R/W	SDN input active level '0' SDN is active low i.e. automatic shutdown occurs when debounced SDN is low. '1' SDN is active high i.e. automatic shutdown occurs when debounced SDN is high
SDN Detection Control	7	R/W	Disable automatic power down upon SDN detection '0' SDN detection causes automatic power down of SIM2 interface '1' SDN detection doesn't cause automatic power down of SIM2 interface

(1) Reset value: 00h

**Table 11. General Purpose Register (15h)<sup>(1)</sup>**

Function	Bit(s)	Type (R/W)	Description
SDN pull-up control	0	R/W	'0' SDN input pull-up enabled '1' SDN input pull-up disabled
SDN pull-down control	1	R/W	'0' SDN pull-down disabled '1' SDN pull-down enabled
RFU	7:2	R/W	

(1) The RFU bits shall allow for the write operation to complete but shall read as '0'. The SW should write '0' into these locations, reset value.

## BASIC DEVICE OPERATION

The TXS02326A is controlled through a standard I<sup>2</sup>C interface reference to VDDIO. It is connected between the two SIM card slots and the SIM/UICC interface of the baseband. The device uses VBAT and VDDI/O as supply voltages. The supply voltage for each SIM card is generated by an on-chip low drop out regulator. The interface between the baseband and the TXS02326A is reference to VDDIO while the interface between the TXS02326A and the SIM card is referenced to the LDO output of either VSIM1 or VSIM2 depending on which slot is being selected. The VDDIO on the baseband side normally does not exceed 1.8V, thus voltage level shifting is needed to support a 3V SIM/UICC interface (Class B).

The TXS02326A has two basic states, the reset and operation state. The baseband utilizes information in the status registers to determine how to manipulate the control registers to properly switch between two SIM cards. These fundamental sequences are outlined below and are to help the user to successfully incorporate this device into the system.

### DEVICE ADDRESS

The address of the device is shown below:

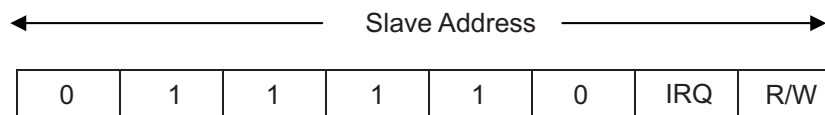

**Address Reference**

IRQ @ Reset	R/W	Slave Address
0	0 (W)	120 (decimal), 78(h)
0	1 (R)	121 (decimal), 79(h)
1	0 (W)	122 (decimal), 7A(h)
1	1 (R)	123 (decimal), 7B(h)

### RESET STATE

In the reset state the device settings are brought back to their default values and any SIM card that has been active is deactivated. After reset, neither of the UICC/SIM interfaces is selected. The active pull-downs at the UICC/SIM interface are automatically activated. To ensure the system powers up in an operational state, device uses an internal 32 KHz clock for internal timing generation. After power up, the system has the option to continue to utilize the internal clock or select an external clock source. This clock source is selectable by the Clock Source Select I<sup>2</sup>C register bit.

- Power up the TXS02326A by asserting VBAT to enter the operation state
- I<sup>2</sup>C Interface becomes active with the VDD\_I/O supply

RESET summary:

- Any pending interrupts are cleared
- I<sup>2</sup>C registers are in the default state
- BSI and SDN counter value in the registers are set to four clock cycles or “0000 0100”
- Both on chip regulators are set to 1.8V and disabled
- All SIM1 and SIM2 signals are pulled to GND

## SETTING UP THE SIM INTERFACE

The TXS02326A supports both Class C (1.8V) or Class B (2.95V) SIM cards. In order to support these cards types, the interface on the SIM side needs to be properly setup. After power up, the system should default to SIM1 card. The following sequence outlines a rudimentary sequence of preparing the SIM1 card interface:

- Configure the SIM1 regulator to 1.8V by asserting B1 = 0 in the SIM Interface Control Register (08h). The system by default should start in 1.8V mode.
- Configure the OE signal by asserting B0 = 0 in the Device Control Register (0Eh). The default value essentially disables the OE pin and the device is configured as an auto direction translator.
- The baseband SIM interface is set to a LOW state.
- Disable the SIM1 interface by asserting B2 = 0 and B3 = 0 in the SIM Interface Control Register.
- Disable the SIM2 interface by asserting B6 = 0 and B7 = 0 in the SIM Interface Control Register.
- VSIM1 voltage regulator should now be activated by asserting B0 = 1 in the SIM Interface Control Register.
- Enable the SIM1 interface by asserting B2 = 1 and B3 = 1 in the SIM Interface Control Register.
- The SIM1 interface (VSIM1, SIM1CLK, SIM1I/O) is now active. The TXS02326A relies on the baseband to perform the power up sequencing of the SIM card. If there is lack of communication between the baseband and the SIM card, the SIM1 interface must be powered-down and then powered up again through the regulator by configuring it to 2.95V by asserting B1 = 1 in the SIM Interface Control Register.

## SWITCHING BETWEEN SIM CARDS

The following sequence outlines a rudimentary sequence of switching between the SIM1 card and SIM2 card:

- Put the SIM1 card interface into “clock stop” mode then assert B2 = 1 and B3 = 0 in the SIM Interface Control Register (08h). This will latch the state of the SIM1 interface (SIM1CLK, SIM1I/O, SIM1RST).
- There can be two scenarios when switching to SIM2 card:
  - SIM2 may be in the power off mode, B6 = 0 and B7 = 0 in the Status Register (04h). If SIM2 is in power off mode, the SIM/UICC interface will need to be set to the power off state. In this case the baseband will most likely need to go through a power up sequence iteration
  - SIM2 may already be in the “clock stop” mode, B6 = 1 and B7 = 0 in the Status Register (04h). If SIM2 is in “clock stop” mode, the interface between the baseband and the device is set to the clock stop mode levels that correspond to the SIM2 card interface.
- After determining whether the SIM2 card is either in power off mode or clock stop mode, the SIM2 card interface is then activated by asserting B6 = 1 and B7 = 1 in the SIM Interface Control Register (08h) and the negotiation between the baseband and card can continue.
- Switching from SIM2 to SIM1 done in the same manner.

## AUTOMATIC SHUTDOWN

Both SIM card interfaces can be configured to automatically shut down upon disconnecting the battery. The shutdown threshold  $BSI_{Threshold}$  is configured in B3 of the Device Control Register (0Eh). Two threshold levels are available for this configuration. When the BSI input level exceeds the  $BSI_{Threshold}$  level that caused this power-down, both SIM card interfaces will automatically be shut down. If the battery removal interrupt is enabled through B2 of the Device Control Register, then an interrupt will be issued to the baseband on IRQ. This case may happen if the user decides to remove the battery.

There are two scenarios for shutting down each SIM: SIMx is “active”, or in “clock stop” mode. In clock stop mode, when the debounce timer expires, the SIMx signals all go low immediately, then the regulator is disabled one 32KHz cycle later. If SIMx is active, the signals go low and the regulator is disabled in a particular sequence to be described in the next section.

The SIM2 interface can also be configured to automatically shut down via the SDN pin.

**BSI / SDN DEBOUNCE AND AUTOMATIC SHUTDOWN SEQUENCE TIMING**

There are two debounce counters: one each for the BSI and SDN inputs. For each counter, when the device is reset or the related input is “false”, the counter is loaded with the value in the associated Debounce Counter register and the debounced signal (i.e. BSI\_DEB or SDN\_DEB) is subsequently set to a “false” state. When the related input becomes “true”, the counter begins counting down on subsequent CLK rising-edges. (CLK is either the internal or external 32 kHz clock as selected by Clock Source Select)

If the input changes state during the count, the counter is again loaded with the register value. The debounce counter propagates the input signal to the output when the counter expires.

For BSI and BSI\_DEB, the “true” state is high. For SDN and SDN\_DEB, the “true” state is the state stored in the SDN Detection Level register. Once either count reaches zero, the debounced signal switches to the “true” state on the next CLK rising edge. Writing a new value to the SDN detection level register such that SDN is now in the TRUE state will force the debounce counter to zero, but will not generate an interrupt nor initiate a shutdown sequence.

If BSI\_DEB goes high and Battery Removal Interrupt (bit 2 of the Device Control Register) is 1, an interrupt is generated and appears on IRQ. Also, if BSI\_DEB goes high and BSI Detection Control (bit 4 of the Device Control Register) is 0, the Automatic Shutdown sequence begins for both SIM’s.

If SDN\_DEB goes “true” and SDN Detection Interrupt (bit 5 of the Device Control Register) is 1, an interrupt is generated and appears on IRQ. Also, if SDN\_DEB goes “true” and SDN Detection Control (bit 7 of the Device Control Register) is 0, the Automatic Shutdown sequence begins for SIM2 only, leaving SIM1 unaffected.

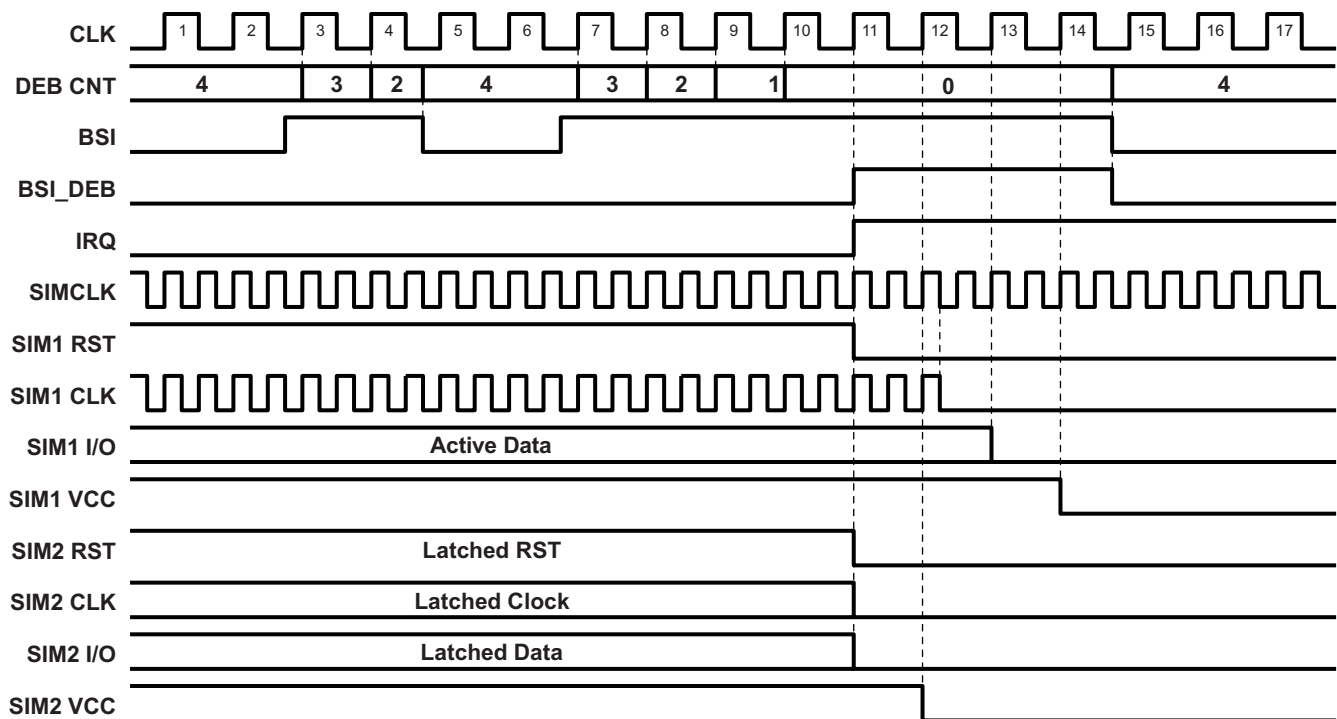
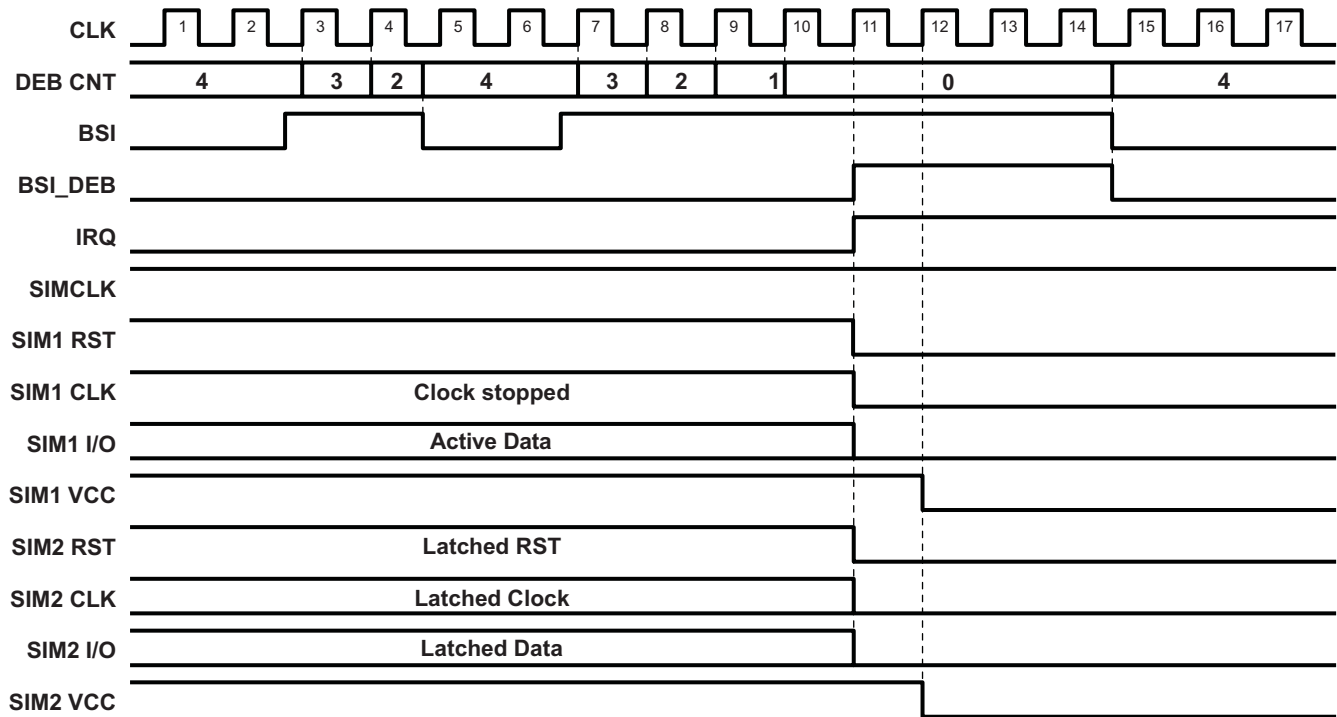

**Figure 2. BSI Debounce Timing – SIM1 Active and SIM2 Isolated**

**Notes:**

- BSI debounce count value set to 4
- SIM1 Active, SIM2 powered but Isolated
- BSI Detection Control set to 0
- Battery Removal Interrupt set to 1

Once BSI is high for four cycles, BSI\_DEB goes high causing automatic shutdown sequence on both SIMs. Since SIM1 is active with SIMCLK running, it follows the staged shutdown sequence. Since SIM2 is powered up but inactive, it follows the instant shutdown sequence.



**Figure 3. BSI Debounce Timing – SIM1 Clock Stop and SIM2 Isolated**

**Notes:**

- BSI debounce counter set to 4
- SIM1 Active in Clock Stop Mode
- SIM2 powered but Isolated
- BSI Detection Control set to 0
- Battery Removal Interrupt set to 1

Once BSI is high for four cycles, BSI\_DEB goes high causing automatic shutdown sequence on both SIMs. Since SIM1 is active with SIMCLK stopped, it follows the instant shutdown sequence. Since SIM2 is powered up but inactive, it follows the instant shutdown sequence.

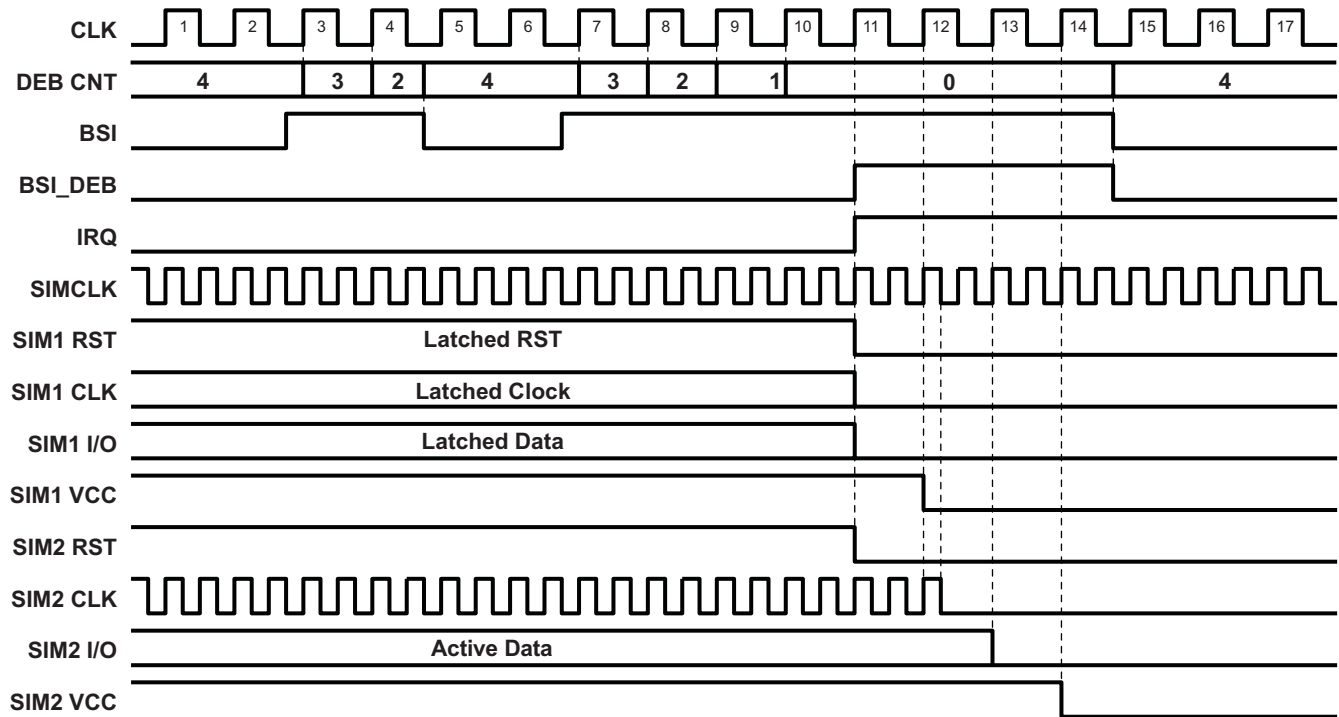

Figure 4. BSI Debounce Timing – SIM1 Isolated, SIM2 Active

**Notes:**

- BSI debounce counter set to 4
- SIM2 Active
- SIM1 powered but Isolated
- BSI Detection Control set to 0
- Battery Removal Interrupt set to 1

Once BSI is high for four cycles, BSI\_DEB goes high causing automatic shutdown sequence on both SIMs. Since SIM2 is active with SIMCLK running, it follows the staged shutdown sequence. Since SIM1 is powered up but inactive, it follows the instant shutdown sequence.

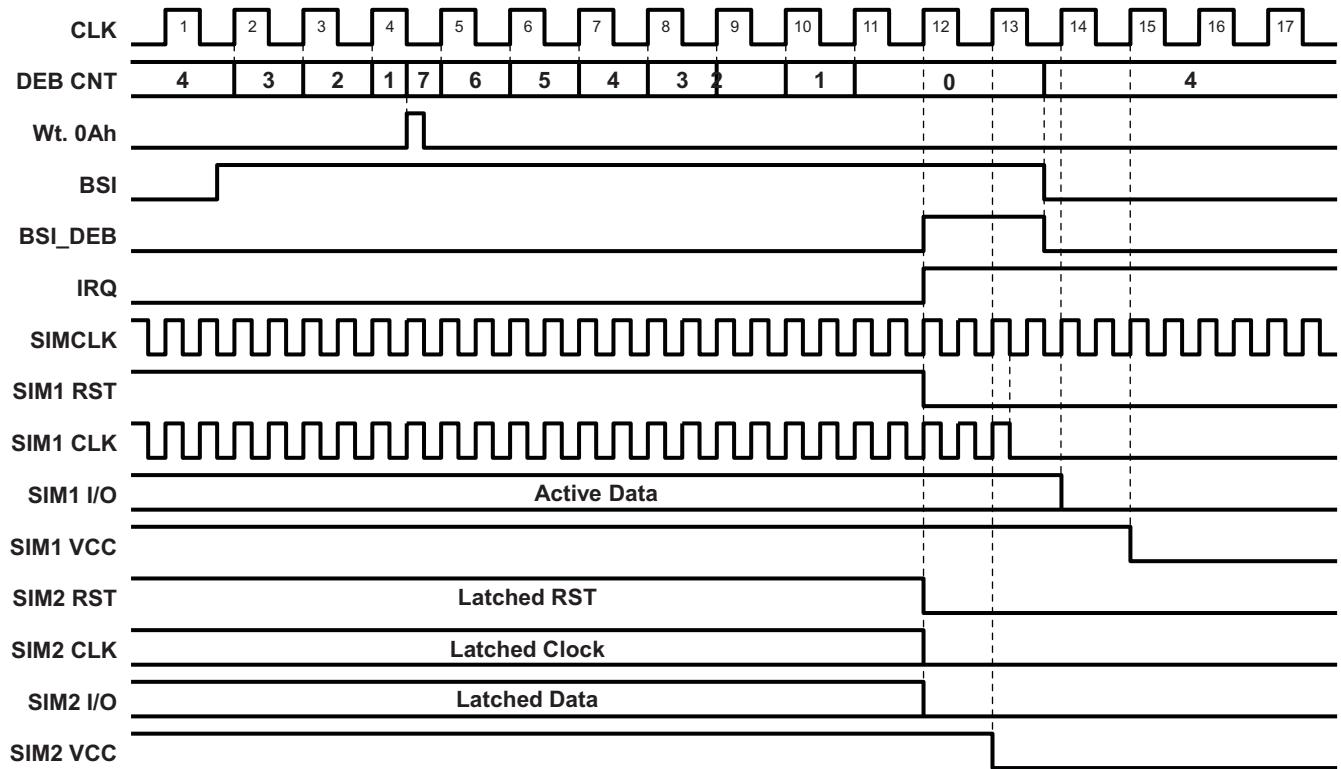

Figure 5. BSI Debounce Timing – Debounce Count Value Write During Debounce

**Notes:**

- BSI debounce count value set to 4, but written to 7 during debounce
- SIM1 Active
- SIM2 powered but Isolated
- BSI Detection Control set to 0
- Battery Removal Interrupt set to

BSI\_DEB goes high causing automatic shutdown sequence on both SIM's. Since SIM1 follows the staged shutdown sequence. SIM2 follows the instant shutdown sequence. BSI returning low does not interrupt shutdown sequence.

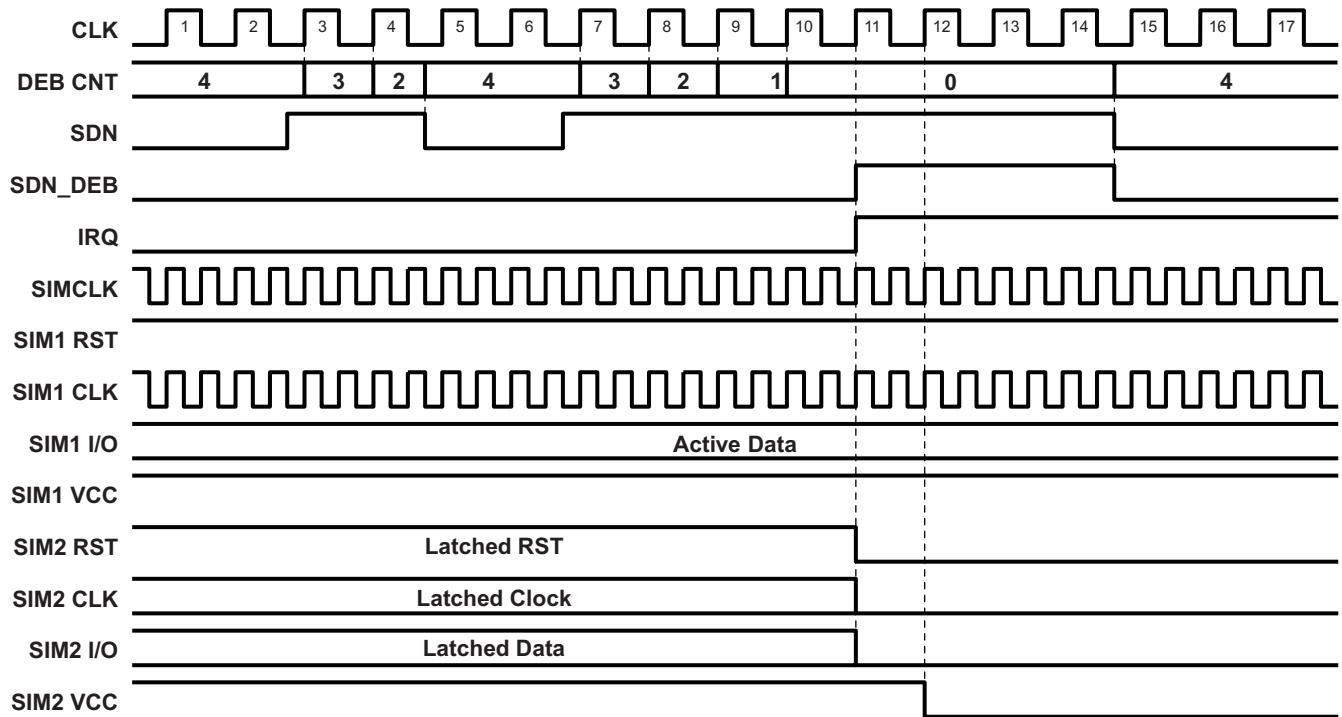

Figure 6. SDN Debounce Timing – SDN Detection Level High

**Notes:**

- SDN debounce count value set to 4
- SIM1 Active
- SIM2 powered but Isolated
- SDN Detection Control set to 0
- SDN Detection level set to 1
- SDN Detection Interrupt set to 1

Once SDN is high for four cycles, SDN\_DEB goes high causing automatic shutdown sequence on SIM2. SIM1 is unaffected. Since SIM2 is powered up but inactive, it follows the instant shutdown sequence.

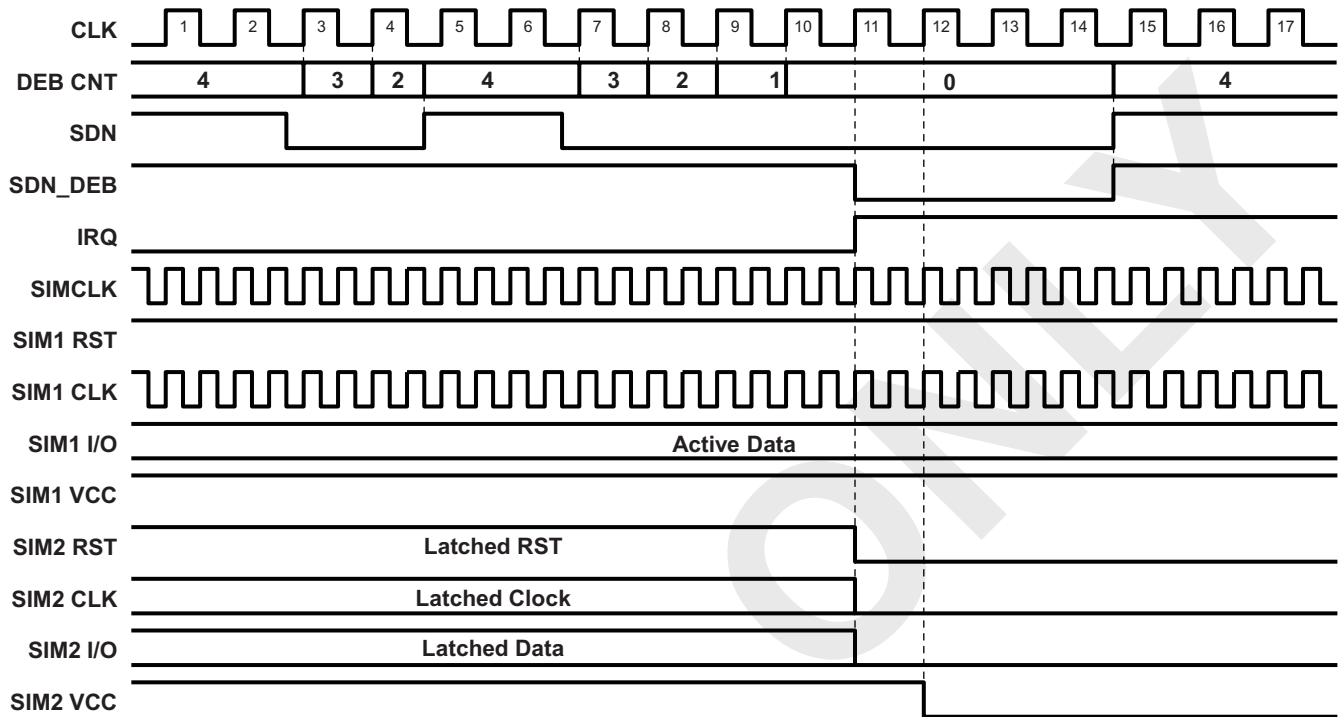

Figure 7. SDN Debounce Timing – SDN Detection Level Low

**Notes:**

- SDN debounce count value set to 4
- SIM1 Active
- SIM2 powered but Isolated
- SDN Detection Control set to 0
- SDN Detection level set to 0
- SDN Detection Interrupt set to 1

Once SDN is low for four cycles, SDN\_DEB goes low causing automatic shutdown sequence on SIM2. SIM1 is unaffected. Since SIM2 is powered up but inactive, it follows the instant shutdown sequence.

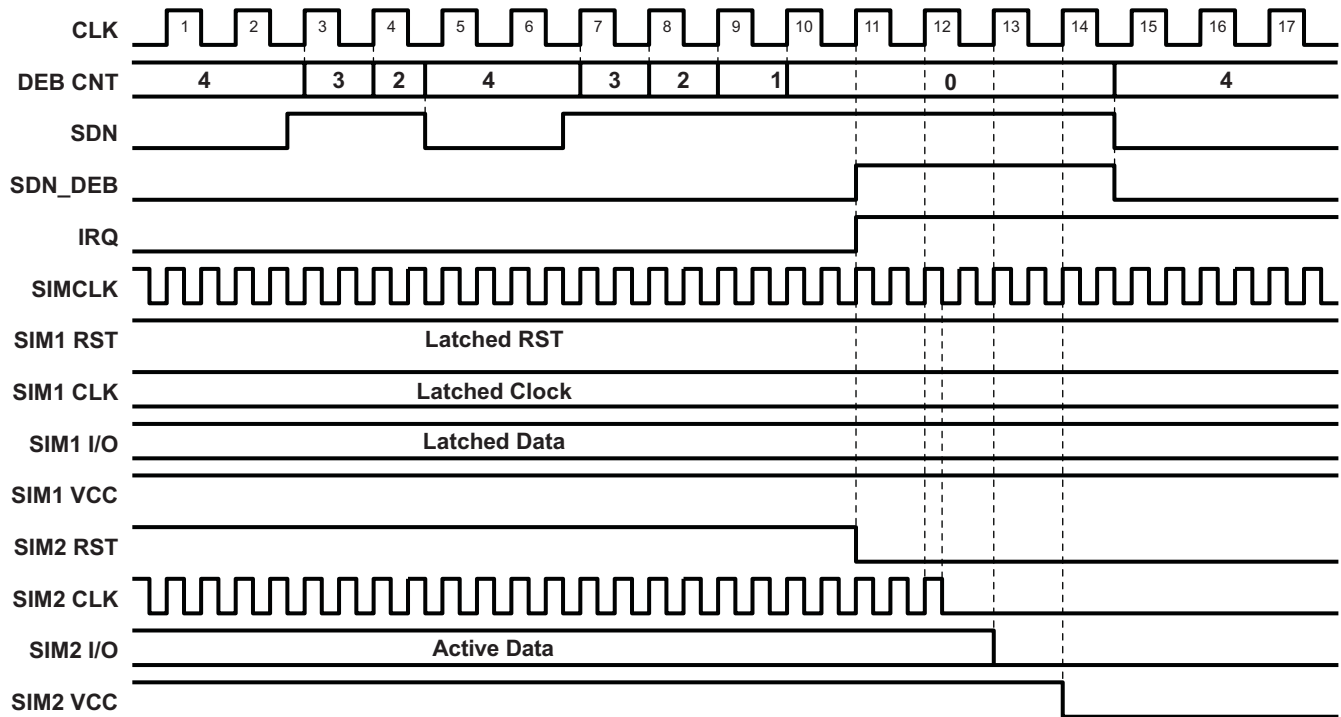

Figure 8. SDN Debounce Timing – SIM1 Isolated and SIM 2 Active

**Notes:**

- SDN debounce count value set to 4
- SIM1 powered but Isolated
- SIM2 Active
- SDN Detection Control set to 0
- SDN Detection level set to 1
- SDN Detection Interrupt set to 1

SDN\_DEB goes high causing automatic shutdown sequence on SIM2. Since SIM2 is active with SIMCLK running, it follows the staged shutdown sequence, SIM1 is unaffected.

## ABSOLUTE MAXIMUM RATINGS

over operating free-air temperature range (unless otherwise noted)

### Level Translator<sup>(1)</sup>

			MIN	MAX	UNIT
VDDIO	Supply voltage range		-0.3	4.0	V
V <sub>I</sub>	Input voltage range	VDDIO-port	-0.5	4.6	V
		VSIMx-port	-0.5	4.6	
		Control inputs	-0.5	4.6	
V <sub>O</sub>	Voltage range applied to any output in the high-impedance or power-off state	VDDIO-port	-0.5	4.6	V
		VSIMx-port	-0.5	4.6	
V <sub>O</sub>	Voltage range applied to any output in the high or low state	VDDIO-port	-0.5	4.6	V
		VSIMx-port	-0.5	4.6	
I <sub>IK</sub>	Input clamp current	V <sub>I</sub> < 0		-50	mA
I <sub>OK</sub>	Output clamp current	V <sub>O</sub> < 0		-50	mA
I <sub>O</sub>	Continuous output current			±50	mA
	Continuous current through V <sub>CCA</sub> or GND			±100	mA
T <sub>stg</sub>	Storage temperature range		-65	150	°C
ESD rating	Human-Body Model (HBM)	All pins		2.5	kV
	Human-Body Model (HBM-HV)	Baseband Side I/O: SIM1CLK, SIM1I/O, SIM1RST, SIM2CLK, SIM2I/O, SIM2RST		6	Kv
	Charge-Device Model (CDM)			1000	V

(1) Stresses beyond those listed under "absolute maximum ratings" may cause permanent damage to the device. These are stress ratings only, and functional operation of the device at these or any other conditions beyond those indicated under "recommended operating conditions" is not implied. Exposure to absolute-maximum-rated conditions for extended periods may affect device reliability.

### LDO<sup>(1)</sup>

			MIN	MAX	UNIT
V <sub>IN</sub>	Input voltage range		-0.3	6	V
V <sub>OUT</sub>	Output voltage range		-0.3	6	V
T <sub>J</sub>	Junction temperature range		-55	150	°C
T <sub>stg</sub>	Storage temperature range		-55	150	°C
ESD rating	Human-Body Model (HBM-HV)	LDO Output: VSIM1, VSIM2		6	kV
	Charged-Device Model (CDM)			1000	V

(1) Stresses beyond those listed under "absolute maximum ratings" may cause permanent damage to the device. These are stress ratings only, and functional operation of the device at these or any other conditions beyond those indicated under "recommended operating conditions" is not implied. Exposure to absolute-maximum-rated conditions for extended periods may affect device reliability.

**THERMAL IMPEDANCE RATINGS**

			UNIT
$\theta_{JA}$	Package thermal impedance <sup>(1)</sup>	RGE package	45 °C/W

(1) The package thermal impedance is calculated in accordance with JESD 51-7.

**RECOMMENDED OPERATING CONDITIONS<sup>(1)</sup>**
**Level Translator**

		Description	MIN	MAX	UNIT
VDDIO	Supply voltage		1.7	3.3	V
V <sub>IH</sub>	High-level input voltage	Applies to pins: RESET, SDN, SCL, SDA, IRQ, OE, 32kHz, SIM_RST, SIM_CLK, SIM_I/O	VDDIO × 0.7	1.9	V
V <sub>IL</sub>	Low-level input voltage		0	VDDIO × 0.3	V
$\Delta t/\Delta v$	Input transition rise or fall rate			5	ns/V
T <sub>A</sub>	Operating free-air temperature		-40	85	°C

(1) All unused data inputs of the device must be held at V<sub>CCI</sub> or GND to ensure proper device operation. Refer to the TI application report, *Implications of Slow or Floating CMOS Inputs*, literature number SCBA004.

## ELECTRICAL CHARACTERISTICS

### Level Translator

over recommended operating free-air temperature range (unless otherwise noted)

PARAMETER		TEST CONDITIONS	VDDIO	VSIM1	VSIM2	MIN	TYP <sup>(1)</sup>	MAX	UNIT		
V <sub>OH</sub>	SIM1_RST	I <sub>OH</sub> = -100 µA Push-Pull	1.7 V to 3.3 V	1.8 V / 2.95 V (Supplied by LDO)	1.8 V / 2.95 V (Supplied by LDO)	VSIM1 × 0.8			V		
	SIM1_CLK					VSIM1 × 0.8					
	SIM1_I/O	I <sub>OH</sub> = -10 µA Open-Drain				VSIM1 × 0.8					
		I <sub>OH</sub> = -100 µA Push-Pull									
	SIM2_RST	I <sub>OH</sub> = -100 µA Push-Pull						VSIM2 × 0.8			
	SIM2_CLK							VSIM2 × 0.8			
	SIM2_I/O	I <sub>OH</sub> = -10 µA Open-Drain						VSIM2 × 0.8			
		I <sub>OH</sub> = -100 µA Push-Pull									
SIM_I/O	I <sub>OH</sub> = -10 µA Open-Drain					VDDIO × 0.8					
	I <sub>OH</sub> = -100 µA Push-Pull										
V <sub>OL</sub>	SIM1_RST	I <sub>OL</sub> = 1 mA Push-Pull	1.7 V to 3.3 V	1.8 V / 2.95 V (Supplied by LDO)	1.8 V / 2.95 V (Supplied by LDO)			VSIM1 × 0.2	V		
	SIM1_CLK	I <sub>OL</sub> = 1 mA Push-Pull						VSIM1 × 0.2			
	SIM1_I/O	I <sub>OL</sub> = 1 mA Open-Drain						0.3			
		I <sub>OL</sub> = 1 mA Push-Pull									
	SIM2_RST	I <sub>OL</sub> = 1 mA Push-Pull						VSIM2 × 0.2			
	SIM2_CLK	I <sub>OL</sub> = 1 mA Push-Pull						VSIM2 × 0.2			
	SIM2_I/O	I <sub>OL</sub> = 1 mA Open-Drain						0.3			
		I <sub>OL</sub> = 1 mA Push-Pull									
SIM_I/O	I <sub>OL</sub> = 1 mA Open-Drain			0.3							
	I <sub>OL</sub> = 1 mA Push-Pull										
I <sub>I</sub>	Control inputs	V <sub>I</sub> = OE	1.7 V to 3.3 V	1.8 V / 2.95 V (Supplied by LDO)	1.8 V / 2.95 V (Supplied by LDO)			±1	µA		
C <sub>IO</sub>	SIM_I/O port						7		pF		
	SIMx port						4				
C <sub>I</sub>	Control inputs	V <sub>I</sub> = VDDIO or GND					3		pF		
	Clock input										

(1) All typical values are at T<sub>A</sub> = 25°C.

## ELECTRICAL CHARACTERISTICS LDO (Control Input Logic = High)

over operating free-air temperature range (unless otherwise noted)

PARAMETER		TEST CONDITIONS		MIN	TYP <sup>(1)</sup>	MAX	UNIT
V <sub>BAT</sub>	Input voltage			2.3		5.5	V
V <sub>OUT</sub>	Output voltage	Class-B Mode		2.85	2.95	3.05	V
		Class-C Mode		1.7	1.8	1.9	
V <sub>DO</sub>	Dropout voltage	I <sub>OUT</sub> = 50 mA				100	mV
I <sub>GND</sub>	Ground-pin current	I <sub>OUT</sub> = 0 mA				35	μA
		I <sub>OUT</sub> = 50 mA				150	
I <sub>OUT(SC)</sub>	Short-circuit current	R <sub>L</sub> = 0 Ω				400	mA
C <sub>OUT</sub>	Output Capacitor				1		μF
PSRR	Power-supply rejection ratio	V <sub>BAT</sub> = 3.25 V, V <sub>SIMx</sub> = 1.8 V or 3 V, C <sub>OUT</sub> = 1 μF, I <sub>OUT</sub> = 50 mA	f = 1 kHz	50			dB
			f = 10 kHz	40			
T <sub>STR</sub>	Start-up time	V <sub>SIMx</sub> = 1.8 V or 3 V, I <sub>OUT</sub> = 10 mA, C <sub>OUT</sub> = 1 μF				50	μS
T <sub>J</sub>	Operating junction temperature			-40		85	°C

 (1) All typical values are at T<sub>A</sub> = 25°C.

## GENERAL ELECTRICAL CHARACTERISTICS

over operating free-air temperature range (unless otherwise noted)

PARAMETER		TEST CONDITIONS		MIN	TYP	MAX	UNIT
I <sub>BAT_ACT</sub>	V <sub>BAT</sub> Current Consumption in Active Mode	RSTX = High, V <sub>SIMx</sub> = 1.8 V or 2.95 V, I <sub>OUT</sub> = 0 mA V <sub>BAT</sub> = 2.3 to 5.5 V V <sub>DDIO</sub> = 1.7 to 3.3 V				250	μA
I <sub>BAT_SDN</sub>	V <sub>BAT</sub> Current Consumption in Shutdown Mode	RSTX = Low, V <sub>SIMx</sub> = 0 V (Disabled), I <sub>OUT</sub> = 0 mA V <sub>BAT</sub> = 2.3 to 5.5 V V <sub>DDIO</sub> = 1.8 V			1	5	
I <sub>DDIO_ACT</sub>	V <sub>DDIO</sub> Current Consumption in Active Mode	RSTX = High, V <sub>SIMx</sub> = 1.8 V or 2.95 V, I <sub>OUT</sub> = 0 mA V <sub>BAT</sub> = 2.3 to 5.5 V V <sub>DDIO</sub> = 1.7 to 3.3 V				5	
I <sub>DDIO_SDN</sub>	V <sub>DDIO</sub> Current Consumption in Shutdown Mode	RSTX = Low, V <sub>SIMx</sub> = 0 V (Disabled), I <sub>OUT</sub> = 0 mA V <sub>BAT</sub> = 2.3 to 5.5 V V <sub>DDIO</sub> = 1.7 to 3.3 V				0.25	
BSI <sub>Threshold</sub>	Comparator Threshold	BSI detection level "1"		1.6		1.7	V
		BSI detection level "0"		1.1		1.3	
Hyst	Internal hysteresis of comparator				±50		mV
CLK <sub>int</sub>	Internal System Clock			-20%	32	+20%	KHz
R <sub>SIMPU</sub>	SIM I/O pull-up			18	20	22.6	kΩ
R <sub>SIMxPU</sub>	SIMx I/O pull-up	Class B		6	7.5	9	kΩ
		Class C		3.8	4.5	5.2	
R <sub>SIMPD</sub>	SIMx I/O pull-down	Active pull-downs are connected to the V <sub>SIM1/2</sub> regulator output to the SIM1/2 CLK, SIM1/2 RST, SIM1/2 I/O when the respective regulator is disabled				2	kΩ

**SWITCHING CHARACTERISTICS****VSIMx = 1.8 V or 2.95 V Supplied by Internal LDO, VBAT = 2.3V to 5.5V**

over recommended operating free-air temperature range (unless otherwise noted)

PARAMETER		TEST CONDITIONS	VDDIO = 1.7 V to 3.3 V		UNIT
			MIN	MAX	
$t_{rA}$ Baseband side to SIM side	SIMx_I/O	Open Drain		320	ns
	SIMx_I/O	Push Pull		8.6	ns
	SIMx_RST	Push Pull		4.3	ns
	SIMx_CLK	Push Pull		9.3	ns
$t_{fA}$ Baseband side to SIM side	SIMx_I/O	Open Drain		16	ns
	SIMx_I/O	Push Pull		6.5	ns
	SIMx_RST	Push Pull		4.5	ns
	SIMx_CLK	Push Pull		9.5	ns
$t_{rB}$ SIM side to Baseband side	SIM_I/O	Open Drain		245	ns
	SIM_I/O	Push Pull		10	ns
$t_{fB}$ SIM side to Baseband side	SIM_I/O	Open Drain		18	ns
	SIM_I/O	Push Pull		8	ns
$f_{max}$	SIMx_CLK	Push Pull		5	MHz
$t_{PLH}$	SIM_CLK to SIMx_CLK	Push Pull		8.9	ns
	SIM_RST to SIMx_RST	Push Pull		8	ns
	SIM_IO to SIMx_IO	Open Drain		18	ns
	SIM_IO to SIMx_IO	Push Pull		10	ns
	SIMx_IO to SIMIO	Open Drain		10	ns
	SIMx_IO to SIMIO	Push Pull		10.5	ns
$t_{PHL}$	SIM_CLK to SIMx_CLK	Push Pull		10	ns
	SIM_RST to SIMx_RST	Push Pull		7	ns
	SIM_IO to SIMx_IO	Open Drain		23	ns
	SIM_IO to SIMx_IO	Push Pull		8	ns
	SIMx_IO to SIM_IO	Open Drain		23	ns
	SIMx_IO to SIM_IO	Push Pull		10	ns

**OPERATING CHARACTERISTICS** $T_A = 25^\circ\text{C}$ ,  $V_{SIMx} = 1.8\text{ V}$  for Class C,  $V_{SIMx} = 2.95\text{ V}$  for Class B

PARAMETER		TEST CONDITIONS	TYP	UNIT
$C_{pd}^{(1)}$	Class B	$C_L = 0$ , $f = 5\text{ MHz}$ , $t_r = t_f = 1\text{ ns}$	11	pF
	Class C		9.5	

(1) Power dissipation capacitance per transceiver

## APPLICATION INFORMATION

The LDO's included on the TXS02326A achieve ultra-wide bandwidth and high loop gain, resulting in extremely high PSRR at very low headroom ( $V_{BAT} - V_{SIM1/2}$ ). The TXS02326A provides fixed regulation at 1.8V or 2.95V. Low noise, enable through I<sup>2</sup>C control, and low ground pin current make it ideal for portable applications. The device offers sub-bandgap output voltages, current limit, thermal protection, and is fully specified from  $-40^{\circ}\text{C}$  to  $+85^{\circ}\text{C}$ .

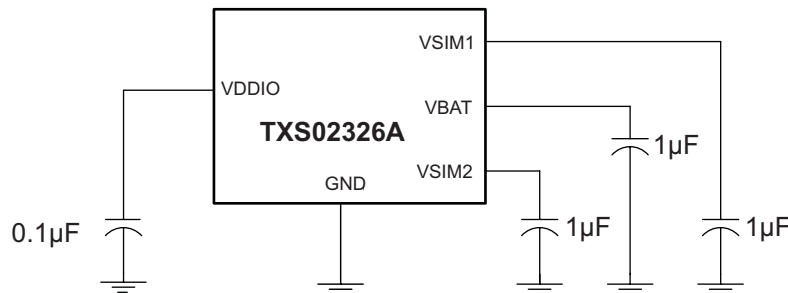

**Figure 9. Typical Application circuit for TXS02326A**

### Input and Output Capacitor Requirements

It is good analog design practice to connect a 1.0  $\mu\text{F}$  low equivalent series resistance (ESR) capacitor across the input supply (VBAT) near the regulator. Also, a 0.1  $\mu\text{F}$  is required for the logic core supply (VDDIO).

This capacitor will counteract reactive input sources and improve transient response, noise rejection, and ripple rejection. A higher-value capacitor may be necessary if large, fast rise-time load transients are anticipated or if the device is located several inches from the power source. The LDO's are designed to be stable with standard ceramic capacitors of values 1.0  $\mu\text{F}$  or larger. X5R- and X7R-type capacitors are best because they have minimal variation in value and ESR over temperature. Maximum ESR should be  $< 1.0 \Omega$ .

### Output Noise

In most LDO's, the bandgap is the dominant noise source. To improve ac performance such as PSRR, output noise, and transient response, it is recommended that the board be designed with separate ground planes for  $V_{IN}$  and  $V_{OUT}$ , with each ground plane connected only at the GND pin of the device. In addition, the ground connection for the bypass capacitor should connect directly to the GND pin of the device.

### Internal Current Limit

The TXS02326A internal current limit helps protect the regulator during fault conditions. During current limit, the output sources a fixed amount of current that is largely independent of output voltage. For reliable operation, the device should not be operated in a current limit state for extended periods of time.

The PMOS pass element in the TXS02326A has a built-in body diode that conducts current when the voltage at  $V_{SIM1/2}$  exceeds the voltage at  $V_{BAT}$ . This current is not limited, so if extended reverse voltage operation is anticipated, external limiting may be appropriate.

### Dropout Voltage

The TXS02326A uses a PMOS pass transistor to achieve low dropout. When  $(V_{BAT} - V_{SIM1/2})$  is less than the dropout voltage ( $V_{DO}$ ), the PMOS pass device is in its linear region of operation and the input-to-output resistance is the  $R_{DS(ON)}$  of the PMOS pass element.  $V_{DO}$  will approximately scale with output current because the PMOS device behaves like a resistor in dropout.

### Startup

The TXS02326A uses a quick-start circuit which allows the combination of very low output noise and fast start-up times. Note that for fastest startup,  $V_{BATT}$  should be applied first, and then enabled by asserting the I<sup>2</sup>C register.

## Transient Response

As with any regulator, increasing the size of the output capacitor reduces over/undershoot magnitude but increases duration of the transient response.

## Minimum Load

The TXS02326A is stable and well-behaved with no output load. Traditional PMOS LDO regulators suffer from lower loop gain at very light output loads. The TXS02326A employs an innovative low-current mode circuit to increase loop gain under very light or no-load conditions, resulting in improved output voltage regulation performance down to zero output current.

## THERMAL INFORMATION

### Thermal Protection

Thermal protection disables the output when the junction temperature rises to approximately +160°C, allowing the device to cool. When the junction temperature cools to approximately +140°C the output circuitry is again enabled. Depending on power dissipation, thermal resistance, and ambient temperature, the thermal protection circuit may cycle on and off. This cycling limits the dissipation of the regulator, protecting it from damage because of overheating.

Any tendency to activate the thermal protection circuit indicates excessive power dissipation or an inadequate heat sink. For reliable operation, junction temperature should be limited to +85°C maximum. To estimate the margin of safety in a complete design (including heat sink), increase the ambient temperature until the thermal protection is triggered; use worst-case loads and signal conditions. For good reliability, thermal protection should trigger at least +35°C above the maximum expected ambient condition of your particular application. This configuration produces a worst-case junction temperature of +85°C at the highest expected ambient temperature and worst-case load.

The internal protection circuitry of the TXS02326A has been designed to protect against overload conditions. It was not intended to replace proper heat sinking. Continuously running the TXS02326A into thermal shutdown will degrade device reliability.

## TYPICAL CHARACTERISTICS

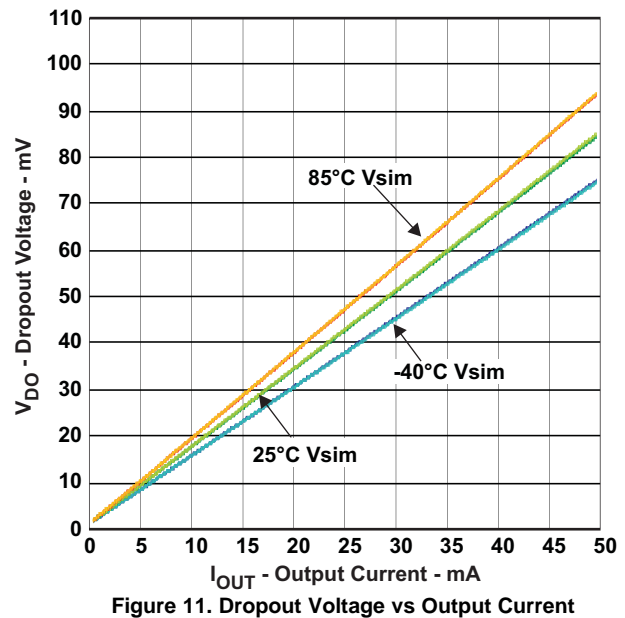
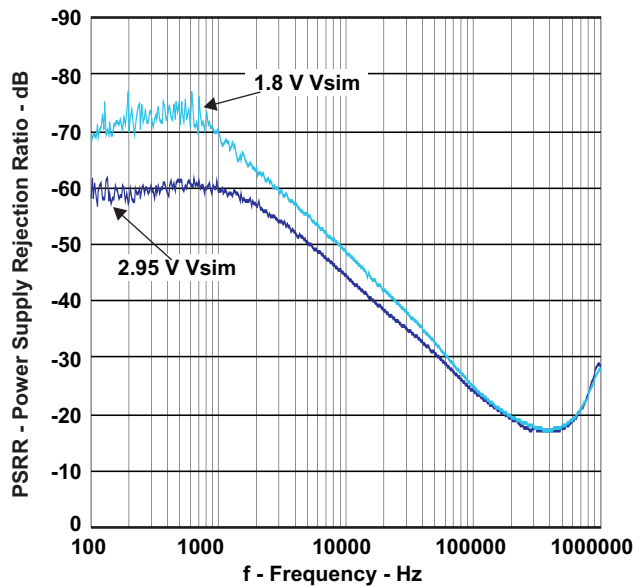

TYPICAL CHARACTERISTICS (continued)

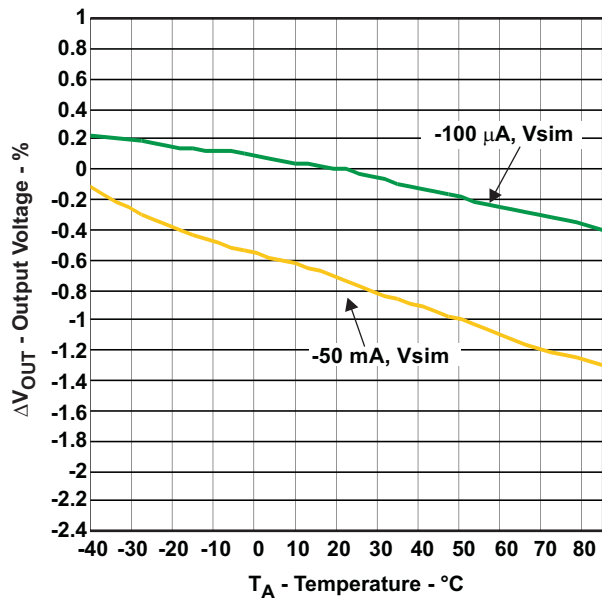

Figure 12. Output Voltage vs Temperature, Class-B/C

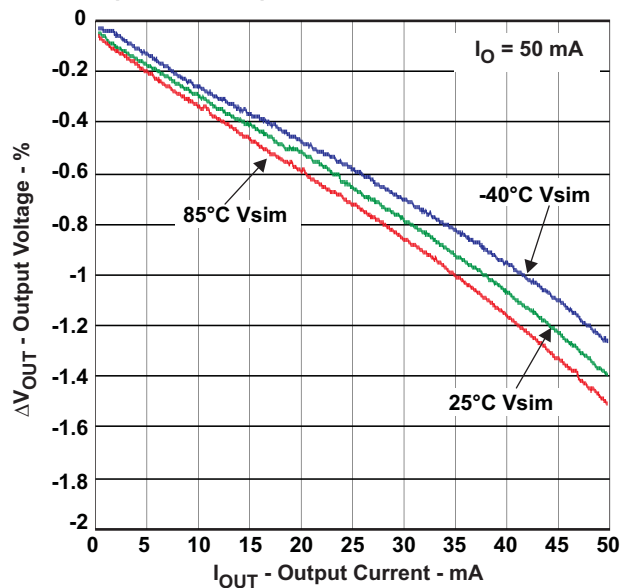

Figure 13. Load Regulation,  $I_{out} = 50 \text{ mA}$ , Class-C

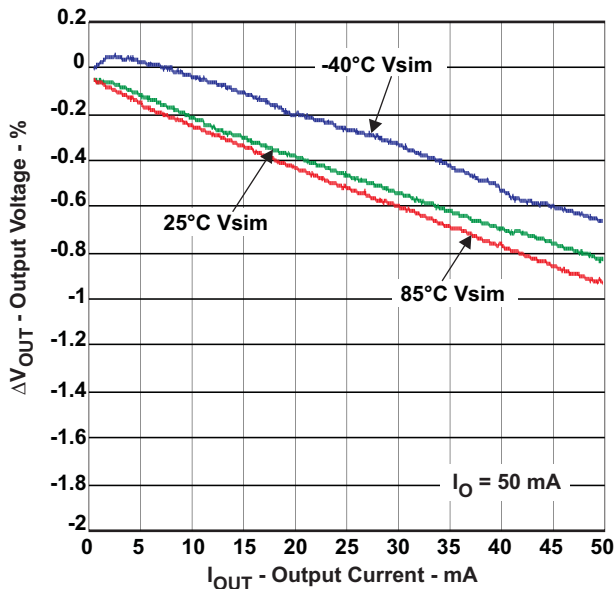

Figure 14. Load Regulation,  $I_{out} = 50 \text{ mA}$ , Class-B

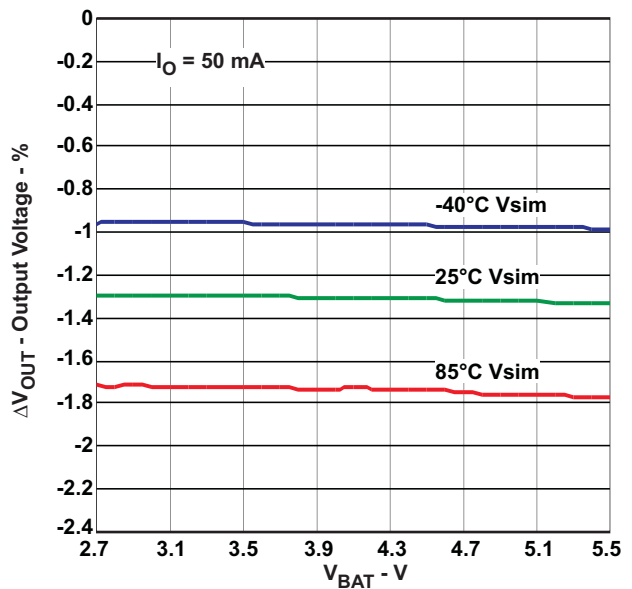

Figure 15. Line Regulation,  $I_{out} = 50 \text{ mA}$ , Class-C

TYPICAL CHARACTERISTICS (continued)

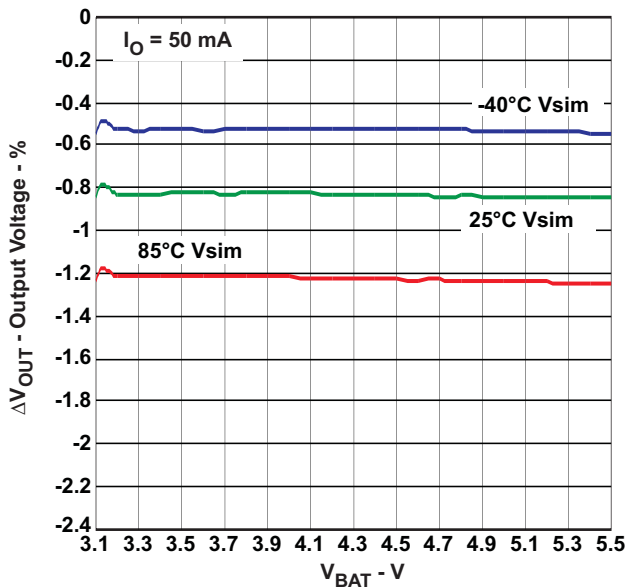

Figure 16. Line Regulation,  $I_{out} = 50 \text{ mA}$ , Class-B

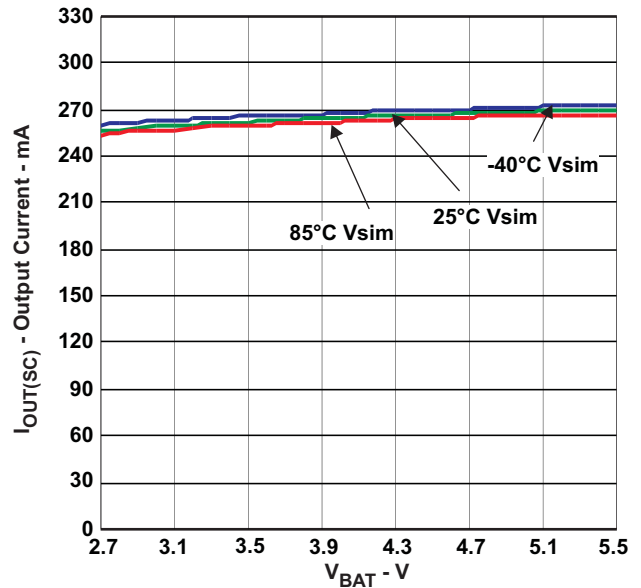

Figure 17. Current Limit vs Input Voltage, Class-B/C

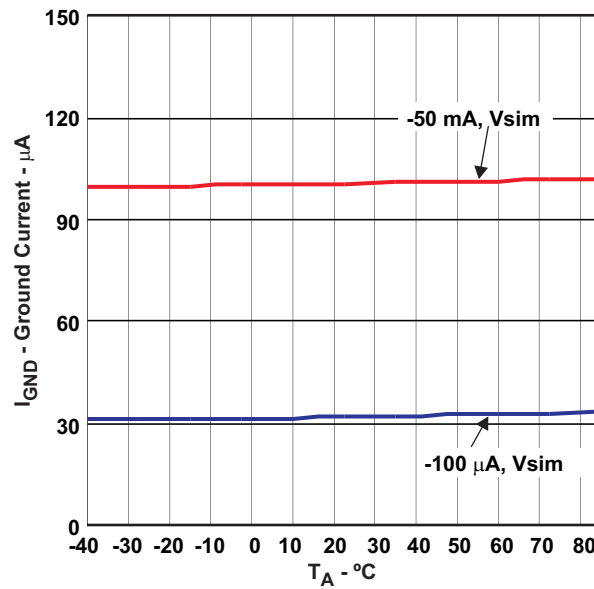

Figure 18. Ground Current vs Temperature, Class-C

## REVISION HISTORY

Changes from Original (May 2012) to Revision A	Page
<ul style="list-style-type: none"> <li>• Deleted <math>I_{SHDN}</math> from LDO characteristics as <math>I_{SHUTDOWN}</math> applies to total device while in the reset mode outlined in the General Characteristics .....</li> </ul>	21
<ul style="list-style-type: none"> <li>• Added <math>I_{BAT\_ACT}</math>, <math>I_{BAT\_SDN}</math>, <math>I_{DDIO\_ACT}</math>, and <math>I_{DDIO\_SDN}</math> to the General Electrical Characteristics table .....</li> </ul>	21

**PACKAGING INFORMATION**

Orderable Device	Status (1)	Package Type	Package Drawing	Pins	Package Qty	Eco Plan (2)	Lead finish/ Ball material (6)	MSL Peak Temp (3)	Op Temp (°C)	Device Marking (4/5)	Samples
TXS02326AMRGER	ACTIVE	VQFN	RGE	24	3000	RoHS & Green	NIPDAU	Level-1-260C-UNLIM	-40 to 85	YJ326A	Samples

(1) The marketing status values are defined as follows:

**ACTIVE:** Product device recommended for new designs.

**LIFEBUY:** TI has announced that the device will be discontinued, and a lifetime-buy period is in effect.

**NRND:** Not recommended for new designs. Device is in production to support existing customers, but TI does not recommend using this part in a new design.

**PREVIEW:** Device has been announced but is not in production. Samples may or may not be available.

**OBSELETE:** TI has discontinued the production of the device.

(2) **RoHS:** TI defines "RoHS" to mean semiconductor products that are compliant with the current EU RoHS requirements for all 10 RoHS substances, including the requirement that RoHS substance do not exceed 0.1% by weight in homogeneous materials. Where designed to be soldered at high temperatures, "RoHS" products are suitable for use in specified lead-free processes. TI may reference these types of products as "Pb-Free".

**RoHS Exempt:** TI defines "RoHS Exempt" to mean products that contain lead but are compliant with EU RoHS pursuant to a specific EU RoHS exemption.

**Green:** TI defines "Green" to mean the content of Chlorine (Cl) and Bromine (Br) based flame retardants meet JS709B low halogen requirements of <=1000ppm threshold. Antimony trioxide based flame retardants must also meet the <=1000ppm threshold requirement.

(3) MSL, Peak Temp. - The Moisture Sensitivity Level rating according to the JEDEC industry standard classifications, and peak solder temperature.

(4) There may be additional marking, which relates to the logo, the lot trace code information, or the environmental category on the device.

(5) Multiple Device Markings will be inside parentheses. Only one Device Marking contained in parentheses and separated by a "-" will appear on a device. If a line is indented then it is a continuation of the previous line and the two combined represent the entire Device Marking for that device.

(6) Lead finish/Ball material - Orderable Devices may have multiple material finish options. Finish options are separated by a vertical ruled line. Lead finish/Ball material values may wrap to two lines if the finish value exceeds the maximum column width.

**Important Information and Disclaimer:**The information provided on this page represents TI's knowledge and belief as of the date that it is provided. TI bases its knowledge and belief on information provided by third parties, and makes no representation or warranty as to the accuracy of such information. Efforts are underway to better integrate information from third parties. TI has taken and continues to take reasonable steps to provide representative and accurate information but may not have conducted destructive testing or chemical analysis on incoming materials and chemicals. TI and TI suppliers consider certain information to be proprietary, and thus CAS numbers and other limited information may not be available for release.

In no event shall TI's liability arising out of such information exceed the total purchase price of the TI part(s) at issue in this document sold by TI to Customer on an annual basis.

**TAPE AND REEL INFORMATION**

**QUADRANT ASSIGNMENTS FOR PIN 1 ORIENTATION IN TAPE**

\*All dimensions are nominal

Device	Package Type	Package Drawing	Pins	SPQ	Reel Diameter (mm)	Reel Width W1 (mm)	A0 (mm)	B0 (mm)	K0 (mm)	P1 (mm)	W (mm)	Pin1 Quadrant
TXS02326AMRGER	VQFN	RGE	24	3000	330.0	12.4	4.25	4.25	1.15	8.0	12.0	Q1

**TAPE AND REEL BOX DIMENSIONS**

\*All dimensions are nominal

Device	Package Type	Package Drawing	Pins	SPQ	Length (mm)	Width (mm)	Height (mm)
TXS02326AMRGER	VQFN	RGE	24	3000	346.0	346.0	33.0

## GENERIC PACKAGE VIEW

RGE 24

VQFN - 1 mm max height

PLASTIC QUAD FLATPACK - NO LEAD



Images above are just a representation of the package family, actual package may vary.  
Refer to the product data sheet for package details.

4204104/H

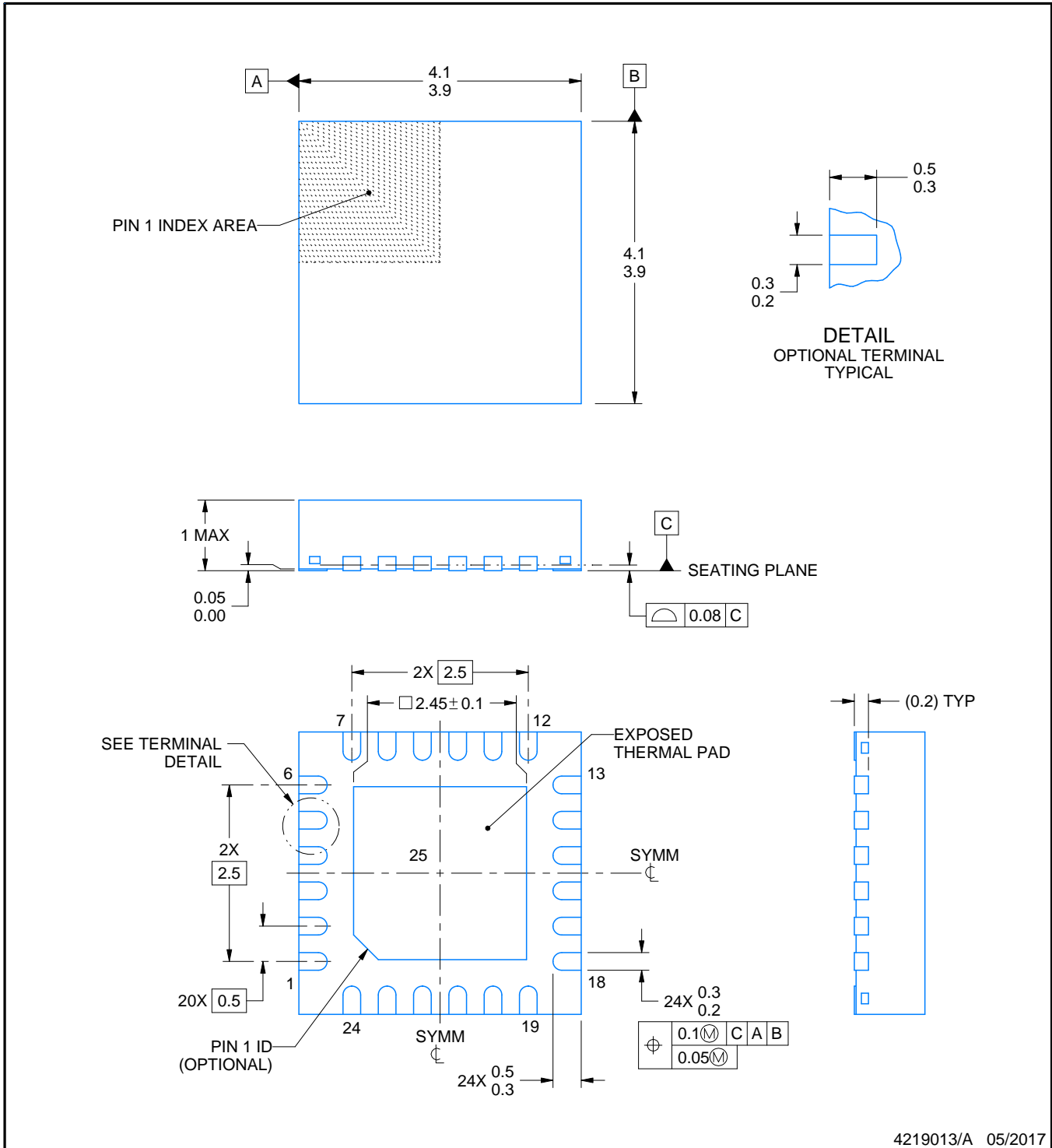
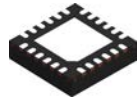

4219013/A 05/2017

NOTES:

1. All linear dimensions are in millimeters. Any dimensions in parenthesis are for reference only. Dimensioning and tolerancing per ASME Y14.5M.
2. This drawing is subject to change without notice.
3. The package thermal pad must be soldered to the printed circuit board for thermal and mechanical performance.





## IMPORTANT NOTICE AND DISCLAIMER

TI PROVIDES TECHNICAL AND RELIABILITY DATA (INCLUDING DATA SHEETS), DESIGN RESOURCES (INCLUDING REFERENCE DESIGNS), APPLICATION OR OTHER DESIGN ADVICE, WEB TOOLS, SAFETY INFORMATION, AND OTHER RESOURCES "AS IS" AND WITH ALL FAULTS, AND DISCLAIMS ALL WARRANTIES, EXPRESS AND IMPLIED, INCLUDING WITHOUT LIMITATION ANY IMPLIED WARRANTIES OF MERCHANTABILITY, FITNESS FOR A PARTICULAR PURPOSE OR NON-INFRINGEMENT OF THIRD PARTY INTELLECTUAL PROPERTY RIGHTS.

These resources are intended for skilled developers designing with TI products. You are solely responsible for (1) selecting the appropriate TI products for your application, (2) designing, validating and testing your application, and (3) ensuring your application meets applicable standards, and any other safety, security, regulatory or other requirements.

These resources are subject to change without notice. TI grants you permission to use these resources only for development of an application that uses the TI products described in the resource. Other reproduction and display of these resources is prohibited. No license is granted to any other TI intellectual property right or to any third party intellectual property right. TI disclaims responsibility for, and you will fully indemnify TI and its representatives against, any claims, damages, costs, losses, and liabilities arising out of your use of these resources.

TI's products are provided subject to [TI's Terms of Sale](#) or other applicable terms available either on [ti.com](https://www.ti.com) or provided in conjunction with such TI products. TI's provision of these resources does not expand or otherwise alter TI's applicable warranties or warranty disclaimers for TI products.

TI objects to and rejects any additional or different terms you may have proposed.

Mailing Address: Texas Instruments, Post Office Box 655303, Dallas, Texas 75265  
Copyright © 2024, Texas Instruments Incorporated

## Looking for pricing, stock, or lifecycle information?

Click below to explore more details on WIN SOURCE:

 [View A6271KLPTR-T-1 on WIN SOURCE](#)

 [Allegro MicroSystems, LLC](#) Information

## Optimize Your Supply Chain with WIN SOURCE Solutions

-  Global Sourcing Solution
-  Obsolete Management
-  Cost Control Management
-  Shortage Management
-  Alternative Solution
-  Excess Inventory Management