



THE DATASHEET OF
932SQ425AKLF



General Description

The 932SQ425 is a reduced-pin-count main clock synthesizer for Intel Romley-generation server platforms. The 932SQ425 is driven with a 25 MHz crystal for maximum performance. It generates CPU outputs of 100 or 133.33 MHz.

Recommended Application

Reduced pin-count CK420BQ

Output Features

- 3 - HCSL CPU outputs
- 3 - HCSL Non-Spread SAS/SRC outputs
- 2 - HCSL SRC outputs
- 1 - HCSL DOT96 output
- 1 - 3.3V 48M output
- 3 - 3.3V PCI outputs
- 1 - 3.3V 14.318M output

Features/Benefits

- 0.5% down spread capable on CPU/SRC/PCI outputs; Lower EMI
- 56-pin MLF package; 21% space savings compared to 932SQ420 64-pin MLF

Key Specifications

- Cycle to cycle jitter: CPU/SRC/NS_SRC/NS_SAS <50ps
- Phase jitter: PCIe Gen2 <3ps rms
- Phase jitter: PCIe Gen3 <x1ps rms
- Phase jitter: QPI 9.6GB/s <0.2ps rms
- Phase jitter: NS-SAS <0.4ps rms using raw phase data
- Phase jitter: NS-SAS <1.3ps rms using Clk Jit Tool 1.6.3

Block Diagram

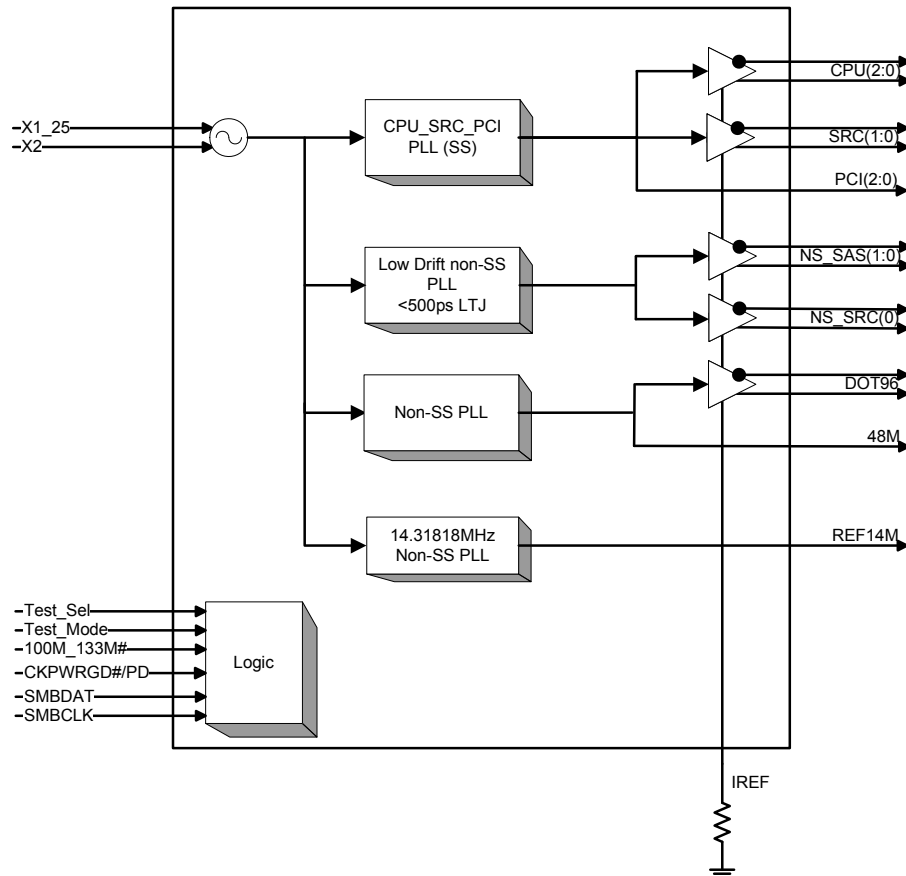

Pin Configuration

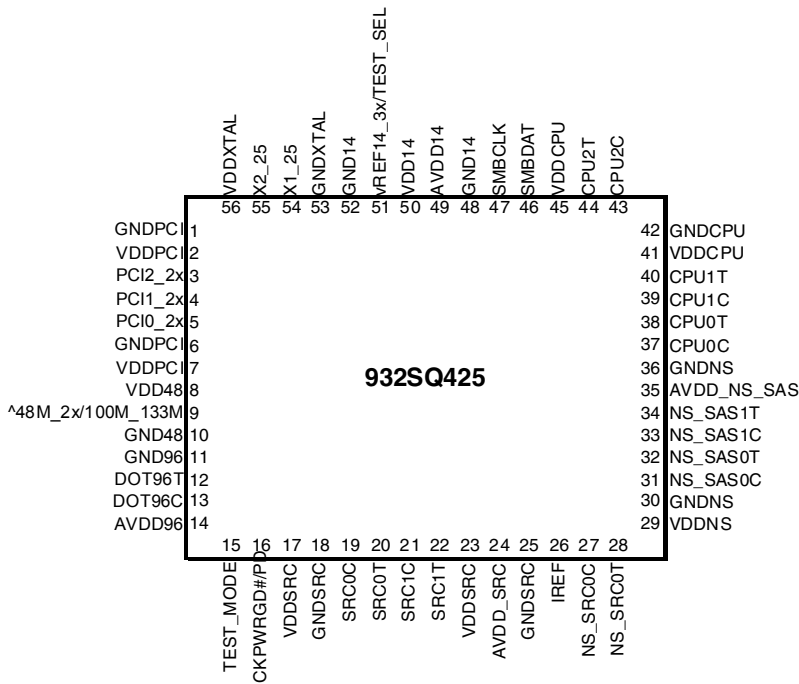

Notes: Pins with ^ prefix have internal 120K pullup
Pins with v prefix have internal 120K pulldown.

932SQ425 Functionality

100M_133M#	CPU	SRC	PCI	REF	NS_SAS NS_SRC	DOT96	USB	
0	133.33	100	33.33	14.318	100.00	96.00	48.00	MHz
1	100							

Spread Spectrum Control

SS_Enable (B1b0)	CPU, SRC & PCI
0	OFF
1	ON

932SQ425 Power Down Functionality

CKPWRGD#/PD	Differential Outputs	Single-ended Outputs	Single ended Outputs w/Latch
1	Hi-Z	Low	Hi-Z
0	Running		

Note: Hi-Z on the differential outputs will result in both True and Complement being low due to the termination network

Power Group Pin Numbers

MLF		Description
VDD	GND	
49	48	14MHz PLL Analog
50	52	REF14M Output and Logic
56	53	25MHz XTAL
2,7	1,6	PCI Outputs and Logic
8	10	48MHz Output and Logic
14	11	96MHz PLL Analog, Output and Logic
17,23	18	SRC Outputs and Logic
24	25	SRC PLL Analog
29	30	Non-Spreading Differential Outputs & Logic
35	36	NS-SAS/SRC PLL Analog
41,45	42	CPU Outputs and Logic

Pin Descriptions

PIN #	PIN NAME	TYPE	DESCRIPTION
1	GNDPCI	PWR	Ground pin for PCI outputs and logic.
2	VDDPCI	PWR	3.3V power for the PCI outputs and logic
3	PCI2_2x	OUT	3.3V PCI clock output
4	PCI1_2x	OUT	3.3V PCI clock output
5	PCI0_2x	OUT	3.3V PCI clock output
6	GNDPCI	PWR	Ground pin for PCI outputs and logic.
7	VDDPCI	PWR	3.3V power for the PCI outputs and logic
8	VDD48	PWR	3.3V power for the 48MHz output and logic
9	^48M_2x/100M_133M#	I/O	3.3V 48MHz output/ 3.3V tolerant CPU frequency select latched input pin. See ViIFS and VihFS values for thresholds. This pin has a weak (~120Kohm) internal pull up. 1 = 100MHz, 0 = 133MHz operating frequency
10	GND48	PWR	Ground pin for 48MHz output and logic.
11	GND96	PWR	Ground pin for DOT96 output and logic.
12	DOT96T	OUT	True clock of differential 96MHz output. These are current mode outputs. These are current mode outputs and external 33 ohm series resistors and 49.9 ohm shunt resistors are required for termination.
13	DOT96C	OUT	Complementary clock of differential 96MHz output. These are current mode outputs and external 33 ohm series resistors and 49.9 ohm shunt resistors are required for termination.
14	AVDD96	PWR	3.3V power for the 48/96MHz PLL and the 96MHz output and logic
15	TEST_MODE	IN	TEST_MODE is a real time input to select between Hi-Z and REF/N divider mode while in test mode. Refer to Test Clarification Table.
16	CKPWRGD#/PD	IN	CKPWRGD# is an active low input used to sample latched inputs and allow the device to Power Up. PD is an asynchronous active high input pin used to put the device into a low power state. The internal clocks and PLLs are stopped.
17	VDDSRC	PWR	3.3V power for the SRC outputs and logic
18	GNDSRC	PWR	Ground pin for SRC outputs and logic.
19	SRC0C	OUT	Complementary clock of differential SRC output. These are current mode outputs and external 33 ohm series resistors and 49.9 ohm shunt resistors are required for termination.
20	SRC0T	OUT	True clock of differential SRC output. These are current mode outputs. These are current mode outputs and external 33 ohm series resistors and 49.9 ohm shunt resistors are required for termination.
21	SRC1C	OUT	Complementary clock of differential SRC output. These are current mode outputs and external 33 ohm series resistors and 49.9 ohm shunt resistors are required for termination.
22	SRC1T	OUT	True clock of differential SRC output. These are current mode outputs. These are current mode outputs and external 33 ohm series resistors and 49.9 ohm shunt resistors are required for termination.
23	VDDSRC	PWR	3.3V power for the SRC outputs and logic
24	AVDD_SRC	PWR	3.3V power for the SRC PLL analog circuits
25	GNDSRC	PWR	Ground pin for SRC outputs and logic.
26	IREF	OUT	This pin establishes the reference current for the differential current-mode output pairs. This pin requires a fixed precision resistor tied to ground in order to establish the appropriate current. 475 ohms is the standard value.
27	NS_SRC0C	OUT	Complementary clock of differential non-spreading SRC output. These are current mode outputs and external 33 ohm series resistors and 49.9 ohm shunt resistors are required for termination.
28	NS_SRC0T	OUT	True clock of differential non-spreading SRC output. These are current mode outputs. These are current mode outputs and external 33 ohm series resistors and 49.9 ohm shunt resistors are required for termination.
29	VDDNS	PWR	3.3V power for the Non-Spreading differential outputs outputs and logic
30	GNDNS	PWR	Ground pin for non-spreading differential outputs and logic.
31	NS_SAS0C	OUT	Complementary clock of differential non-spreading SAS output. These are current mode outputs and external 33 ohm series resistors and 49.9 ohm shunt resistors are required for termination.
32	NS_SAS0T	OUT	True clock of differential non-spreading SAS output. These are current mode outputs. These are current mode outputs and external 33 ohm series resistors and 49.9 ohm shunt resistors are required for termination.
33	NS_SAS1C	OUT	Complementary clock of differential non-spreading SAS output. These are current mode outputs and external 33 ohm series resistors and 49.9 ohm shunt resistors are required for termination.
34	NS_SAS1T	OUT	True clock of differential non-spreading SAS output. These are current mode outputs. These are current mode outputs and external 33 ohm series resistors and 49.9 ohm shunt resistors are required for termination.
35	AVDD_NS_SAS	PWR	3.3V power for the non-spreading SAS/SRC PLL analog circuits.
36	GNDNS	PWR	Ground pin for non-spreading differential outputs and logic.

Pin Descriptions (cont.)

37	CPU0C	OUT	Complementary clock of differential CPU output. These are current mode outputs and external 33 ohm series resistors and 49.9 ohm shunt resistors are required for termination.
38	CPU0T	OUT	True clock of differential CPU output. These are current mode outputs and external 33 ohm series resistors and 49.9 ohm shunt resistors are required for termination.
39	CPU1C	OUT	Complementary clock of differential CPU output. These are current mode outputs and external 33 ohm series resistors and 49.9 ohm shunt resistors are required for termination.
40	CPU1T	OUT	True clock of differential CPU output. These are current mode outputs and external 33 ohm series resistors and 49.9 ohm shunt resistors are required for termination.
41	VDDCPU	PWR	3.3V power for the CPU outputs and logic
42	GNDCPU	PWR	Ground pin for CPU outputs and logic.
43	CPU2C	OUT	Complementary clock of differential CPU output. These are current mode outputs and external 33 ohm series resistors and 49.9 ohm shunt resistors are required for termination.
44	CPU2T	OUT	True clock of differential CPU output. These are current mode outputs and external 33 ohm series resistors and 49.9 ohm shunt resistors are required for termination.
45	VDDCPU	PWR	3.3V power for the CPU outputs and logic
46	SMBDAT	I/O	Data pin of SMBUS circuitry, 5V tolerant
47	SMBCLK	IN	Clock pin of SMBUS circuitry, 5V tolerant
48	GND14	PWR	Ground pin for 14MHz output and logic.
49	AVDD14	PWR	Analog power pin for 14MHz PLL
50	VDD14	PWR	Power pin for 14MHz output and logic
51	vREF14_3x/TEST_SEL	I/O	14.318 MHz reference clock. 3X drive strength as default / TEST_SEL latched input to enable test mode. Refer to Test Clarification Table. This pin has a weak (~120Kohm) internal pull down.
52	GND14	PWR	Ground pin for 14MHz output and logic.
53	GNDXTAL	PWR	Ground pin for Crystal Oscillator.
54	X1_25	IN	Crystal input, Nominally 25.00MHz.
55	X2_25	OUT	Crystal output, Nominally 25.00MHz.
56	VDDXTAL	PWR	3.3V power for the crystal oscillator.

Test Loads and Recommended Terminations

932SQ4xx Differential Test Loads

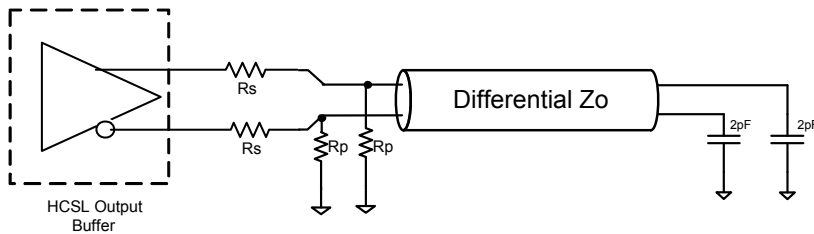

Differential Output Termination Table

DIF Zo (Ω)	Iref (Ω)	Rs (Ω)	Rp (Ω)
100	475	33	50
85	412	27	42.2 or 43.2

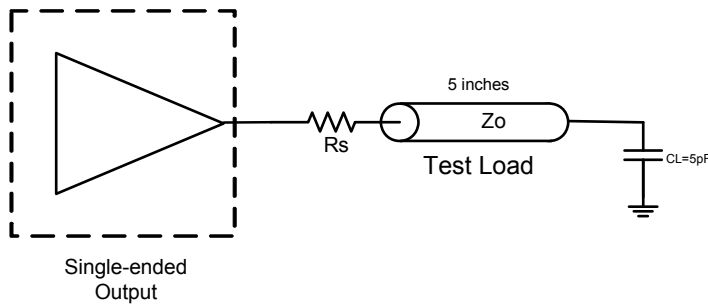

Single-ended Output Termination Table

Output	Loads	Rs Value (for each load)	
		Zo = 50 Ω	Zo = 60 Ω
PCI/USB	1	36	43
PCI/USB	2	22	33
REF	1	39	47
REF	2	27	36
REF	3	10	20

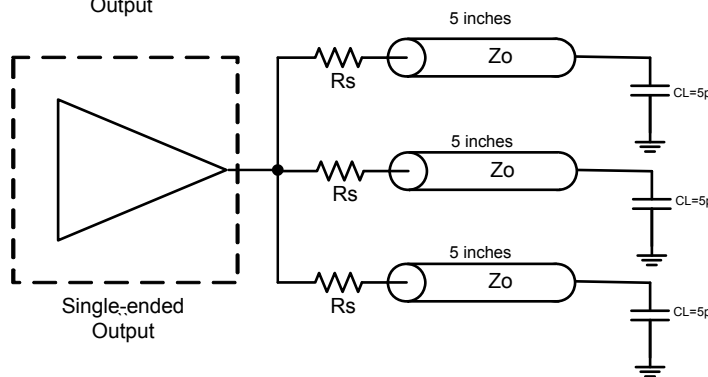
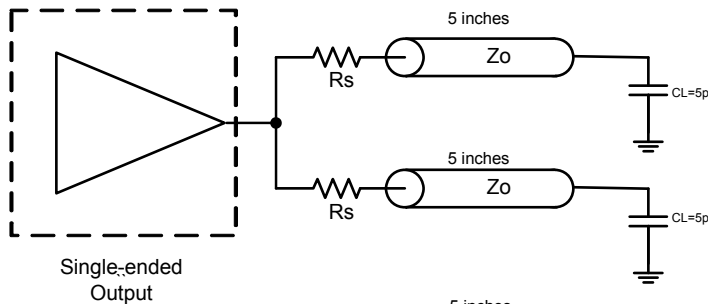

When driving more than one load, each load trace must be equal in length.

Absolute Maximum Ratings

Stresses above the ratings listed below can cause permanent damage to the 932SQ425. These ratings, which are standard values for IDT commercially rated parts, are stress ratings only. Functional operation of the device at these or any other conditions above those indicated in the operational sections of the specifications is not implied. Exposure to absolute maximum rating conditions for extended periods can affect product reliability. Electrical parameters are guaranteed only over the recommended operating temperature range.

PARAMETER	SYMBOL	CONDITIONS	MIN	TYP	MAX	UNITS	NOTES
3.3V Core Supply Voltage	VDDA				4.6	V	1,2
3.3V Logic Supply Voltage	VDD				4.6	V	1,2
Input Low Voltage	V _{IL}		GND-0.5			V	1
Input High Voltage	V _{IH}	Except for SMBus interface			V _{DD} +0.5V	V	1
Input High Voltage	V _{IHSMB}	SMBus clock and data pins			5.5V	V	1
Storage Temperature	T _s		-65		150	°C	1
Junction Temperature	T _j				125	°C	1
Input ESD protection	ESD prot	Human Body Model	2000			V	1

¹Guaranteed by design and characterization, not 100% tested in production.

²Operation under these conditions is neither implied nor guaranteed.

Electrical Characteristics—Current Consumption

T_A = T_{COM}; Supply Voltage VDD = 3.3 V +/-5%

PARAMETER	SYMBOL	CONDITIONS	MIN	TYP	MAX	UNITS	NOTES
Operating Supply Current	I _{DD3.3OP}	All outputs active @100MHz, C _L = Full load;		330	350	mA	1
Powerdown Current	I _{DD3.3PDZ}	All differential pairs tri-stated		16	20	mA	1

¹Guaranteed by design and characterization, not 100% tested in production.

DC Electrical Characteristics—Differential Current Mode Outputs

T_A = T_{COM}; Supply Voltage VDD = 3.3 V +/-5%

PARAMETER	SYMBOL	CONDITIONS	MIN	TYP	MAX	UNITS	NOTES
Slew rate	Trf	Scope averaging on	1	2.4	4	V/ns	1, 2, 3
Slew rate matching	ΔTrf	Slew rate matching, Scope averaging on		9	20	%	1, 2, 4
Voltage High	VHigh	Statistical measurement on single-ended signal using oscilloscope math function. (Scope averaging on)	660	772	850	mV	1
Voltage Low	VLow		-150	9	150		1
Max Voltage	Vmax	Measurement on single ended signal using absolute value.		810	1150	mV	1, 7
Min Voltage	Vmin		-300	-17			1, 7
Vswing	Vswing	Scope averaging off	300	1446		mV	1, 2
Crossing Voltage (abs)	Vcross_abs	Scope averaging off	250	351	550	mV	1, 5
Crossing Voltage (var)	Δ-Vcross	Scope averaging off		24	140	mV	1, 6

¹Guaranteed by design and characterization, not 100% tested in production. I_{REF} = VDD/(3xR_R). For R_R = 475Ω (1%), I_{REF} =

2.32mA. I_{OH} = 6 x I_{REF} and V_{OH} = 0.7V @ Z_O=50Ω (100Ω differential impedance).

²Measured from differential waveform

³Slew rate is measured through the Vswing voltage range centered around differential 0V. This results in a +/-150mV window around differential 0V.

⁴Matching applies to rising edge rate for Clock and falling edge rate for Clock#. It is measured using a +/-75mV window centered on the average cross point where Clock rising meets Clock# falling. The median cross point is used to calculate the voltage thresholds the oscilloscope is to use for the edge rate calculations.

⁵Vcross is defined as voltage where Clock = Clock# measured on a component test board and only applies to the differential rising edge (i.e. Clock rising and Clock# falling).

⁶The total variation of all Vcross measurements in any particular system. Note that this is a subset of V_{cross_min/max} (V_{cross} absolute) allowed. The intent is to limit Vcross induced modulation by setting V_{cross_delta} to be smaller than V_{cross} absolute.

⁷Includes overshoot and undershoot.

Electrical Characteristics–Input/Supply/Common Output Parameters

TA = T_{COM}; Supply Voltage VDD = 3.3 V +/-5%

PARAMETER	SYMBOL	CONDITIONS	MIN	TYP	MAX	UNITS	NOTES
Ambient Operating Temperature	T _{COM}	Commercial range	0		70	°C	1
Input High Voltage	V _{IH}	Single-ended inputs, except SMBus, low threshold and tri-level inputs	2		V _{DD} + 0.3	V	1
Input Low Voltage	V _{IL}	Single-ended inputs, except SMBus, low threshold and tri-level inputs	GND - 0.3		0.8	V	1
Input Current	I _{IN}	Single-ended inputs, V _{IN} = GND, V _{IN} = VDD	-5		5	uA	1
	I _{INP}	Single-ended inputs. V _{IN} = 0 V; Inputs with internal pull up resistors V _{IN} = VDD; Inputs with internal pull-down resistors	-200		200	uA	1
Low Threshold Input-High Voltage	V _{IH_FS}	3.3 V +/-5%	0.7		V _{DD} + 0.3	V	1
Low Threshold Input-Low Voltage	V _{IL_FS}	3.3 V +/-5%	V _{SS} - 0.3		0.35	V	1
Input Frequency	F _i			25.00		MHz	2
Pin Inductance	L _{pin}				7	nH	1
Capacitance	C _{IN}	Logic Inputs			5	pF	1
	C _{OUT}	Output pin capacitance			5	pF	1
	C _{INX}	X1 & X2 pins			5	pF	1
Clk Stabilization	T _{STAB}	From V _{DD} Power-Up and after input clock stabilization or de-assertion of PD# to 1st clock			1.8	ms	1,2
SS Modulation Frequency	f _{MODIN}	Allowable Frequency (Triangular Modulation)	30	31.500	33	kHz	1
Tdrive_PD#	t _{DRVPD}	Differential output enable after PD# de-assertion		200.000	300	us	1,3
Tfall	t _F	Fall time of control inputs			5	ns	1,2
Trise	t _R	Rise time of control inputs			5	ns	1,2
SMBus Input Low Voltage	V _{ILSMB}				0.8	V	1
SMBus Input High Voltage	V _{IHSMB}		2.1		V _{DDSMB}	V	1
SMBus Output Low Voltage	V _{OLSMB}	@ I _{PULLUP}			0.4	V	1
SMBus Sink Current	I _{PULLUP}	@ V _{OL}	4			mA	1
Nominal Bus Voltage	V _{DDSMB}	3V to 5V +/- 10%	2.7		5.5	V	1
SCLK/SDATA Rise Time	t _{RSMB}	(Max VIL - 0.15) to (Min VIH + 0.15)			1000	ns	1
SCLK/SDATA Fall Time	t _{FSMB}	(Min VIH + 0.15) to (Max VIL - 0.15)			300	ns	1
SMBus Operating Frequency	f _{MAXSMB}	Maximum SMBus operating frequency			100	kHz	1

¹Guaranteed by design and characterization, not 100% tested in production.

²Control input must be monotonic from 20% to 80% of input swing.

³Time from deassertion until outputs are >200 mV

AC Electrical Characteristics–Differential Current Mode Outputs

$T_A = T_{COM}$; Supply Voltage $V_{DD} = 3.3\text{ V} \pm 5\%$

PARAMETER	SYMBOL	CONDITIONS	MIN	TYP	MAX	UNITS	NOTES
Duty Cycle	t_{DC}	Measured differentially, PLL Mode	45	50.1	55	%	1
Skew, Output to Output	t_{sk3SRC}	Across all SRC outputs, $V_T = 50\%$		13.5	50	ps	1
Skew, Output to Output	t_{sk3CPU}	Across all CPU outputs, $V_T = 50\%$		43	50	ps	1
Jitter, Cycle to cycle	$t_{cyc-cyc}$	CPU, SRC, NS_SAS outputs		35	50	ps	1,3
		DOT96 output		75	250	ps	1,3

¹ Guaranteed by design and characterization, not 100% tested in production.

² $I_{REF} = V_{DD}/(3 \times R_R)$. For $R_R = 475\Omega$ (1%), $I_{REF} = 2.32\text{mA}$. $I_{OH} = 6 \times I_{REF}$ and $V_{OH} = 0.7\text{V}$ @ $Z_O = 50\Omega$.

³ Measured from differential waveform

Electrical Characteristics–Phase Jitter Parameters

$T_A = 0 - 70^\circ\text{C}$; Supply Voltage $V_{DD}/V_{DDA} = 3.3\text{ V} \pm 5\%$,

PARAMETER	SYMBOL	CONDITIONS	MIN	TYP	MAX	UNITS	Notes
Phase Jitter	$t_{jphPCIeG1}$	PCIe Gen 1		28	86	ps (p-p)	1,2,3,6
	$t_{jphPCIeG2}$	PCIe Gen 2 Lo Band $10\text{kHz} < f < 1.5\text{MHz}$		0.9	3	ps (rms)	1,2,6
		PCIe Gen 2 High Band $1.5\text{MHz} < f < \text{Nyquist (50MHz)}$		1.7	3.1	ps (rms)	1,2,6
	$t_{jphPCIeG3}$	PCIe Gen 3 (PLL BW of 2-4MHz, CDR = 10MHz)		0.4	1	ps (rms)	1,2,4,6
	t_{jphQPI_SMI}	QPI & SMI (100MHz or 133MHz, 4.8Gb/s, 6.4Gb/s 12UI)		0.15	0.5	ps (rms)	1,5,7
		QPI & SMI (100MHz, 8.0Gb/s, 12UI)		0.13	0.3	ps (rms)	1,5,7
		QPI & SMI (100MHz, 9.6Gb/s, 12UI)		0.11	0.2	ps (rms)	1,5,7
	$t_{jphSAS12G}$	SAS 12G (Filtered REFCLK Jitter 20KHz to 20MHz.)		0.34	0.4	ps (rms)	1,8,9
	$t_{jphSAS12G}$	SAS 12G		0.70	1.3	ps (rms)	1,5,8

¹ Guaranteed by design and characterization, not 100% tested in production.

² See <http://www.pcisig.com> for complete specs

³ Sample size of at least 100K cycles. This figures extrapolates to 108ps pk-pk @ 1M cycles for a BER of 1-12.

⁴ Subject to final radification by PCI SIG.

⁵ Calculated from Intel-supplied Clock Jitter Tool v 1.6.6

⁶ Applied to SRC outputs

⁷ Applies to CPU outputs

⁸ Applies to NS_SAS, NS_SRC outputs

⁹ Intel calculation from raw phase noise data

Electrical Characteristics–PCI

$T_A = 0 - 70^\circ\text{C}$; Supply Voltage $V_{DD}/V_{DDA} = 3.3\text{ V} \pm 5\%$,

PARAMETER	SYMBOL	CONDITIONS	MIN	TYP	MAX	UNITS	NOTES
Output Impedance	R_{DSP}	$V_O = V_{DD}*(0.5)$	12		55	Ω	1
Output High Voltage	V_{OH}	$I_{OH} = -1\text{ mA}$	2.4			V	1
Output Low Voltage	V_{OL}	$I_{OL} = 1\text{ mA}$			0.55	V	1
Output High Current	I_{OH}	MIN @ $V_{OH} = 1.0\text{ V}$	-33			mA	1
		MAX @ $V_{OH} = 3.135\text{ V}$			-33	mA	1
Output Low Current	I_{OL}	MIN @ $V_{OL} = 1.95\text{ V}$	30			mA	1
		MAX @ $V_{OL} = 0.4\text{ V}$			38	mA	1
Clock High Time	T_{HIGH}	1.5V	12			ns	1
Clock Low Time	T_{LOW}	1.5V	12			ns	1
Edge Rate	$t_{slew/f}$	Rising/Falling edge rate	1	1.8	4	V/ns	1,2
Duty Cycle	d_{t1}	$V_T = 1.5\text{ V}$	45	50.5	55	%	1
Group Skew	t_{skew}	$V_T = 1.5\text{ V}$		294	500	ps	1
Jitter, Cycle to cycle	$t_{jyc-cyc}$	$V_T = 1.5\text{ V}$		108	500	ps	1

See "Single-ended Test Loads Page" for termination circuits

¹Guaranteed by design and characterization, not 100% tested in production.

²Measured between 0.8V and 2.0V

Electrical Characteristics–48MHz

$T_A = 0 - 70^\circ\text{C}$; Supply Voltage $V_{DD}/V_{DDA} = 3.3\text{ V} \pm 5\%$,

PARAMETER	SYMBOL	CONDITIONS	MIN	TYP	MAX	UNITS	NOTES
Output Impedance	R_{DSP}	$V_O = V_{DD}*(0.5)$	20		60	Ω	1
Output High Voltage	V_{OH}	$I_{OH} = -1\text{ mA}$	2.4			V	1
Output Low Voltage	V_{OL}	$I_{OL} = 1\text{ mA}$			0.55	V	1
Output High Current	I_{OH}	MIN @ $V_{OH} = 1.0\text{ V}$	-29			mA	1
		MAX @ $V_{OH} = 3.135\text{ V}$			-33	mA	1
Output Low Current	I_{OL}	MIN @ $V_{OL} = 1.95\text{ V}$	29			mA	1
		MAX @ $V_{OL} = 0.4\text{ V}$			27	mA	1
Clock High Time	T_{HIGH}	1.5V	8.094		10.036	ns	1
Clock Low Time	T_{LOW}	1.5V	7.694		9.836	ns	1
Edge Rate	t_{slew/f_USB}	Rising/Falling edge rate	1	1.5	2	V/ns	1,2
Duty Cycle	d_{t1}	$V_T = 1.5\text{ V}$	45	51	55	%	1
Jitter, Cycle to cycle	$t_{jyc-cyc}$	$V_T = 1.5\text{ V}$		109	350	ps	1

See "Single-ended Test Loads Page" for termination circuits

¹Guaranteed by design and characterization, not 100% tested in production.

²Measured between 0.8V and 2.0V

Electrical Characteristics–REF

$T_A = 0 - 70^\circ\text{C}$; Supply Voltage $V_{DD}/V_{DDA} = 3.3\text{ V} \pm 5\%$,

PARAMETER	SYMBOL	CONDITIONS	MIN	TYP	MAX	UNITS	Notes
Output Impedance	R_{DSP}	$V_O = V_{DD} * (0.5)$	12		55	Ω	1
Output High Voltage	V_{OH}	$I_{OH} = -1\text{ mA}$	2.4			V	1
Output Low Voltage	V_{OL}	$I_{OL} = 1\text{ mA}$			0.55	V	1
Output High Current	I_{OH}	MIN @ $V_{OH} = 1.0\text{ V}$	-33			mA	1
		MAX @ $V_{OH} = 3.135\text{ V}$			-33	mA	1
Output Low Current	I_{OL}	MIN @ $V_{OL} = 1.95\text{ V}$	30			mA	1
		MAX @ $V_{OL} = 0.4\text{ V}$			38	mA	1
Clock High Time	T_{HIGH}	1.5V	27.5			ns	1
Clock Low Time	T_{LOW}	1.5V	27.5			ns	1
Edge Rate	$t_{slew/f}$	Rising/Falling edge rate	1	1.9	4	V/ns	1,2
Duty Cycle	d_{t1}	$V_T = 1.5\text{ V}$	45	50.5	55	%	1
Jitter, Cycle to cycle	$t_{jyc-cyc}$	$V_T = 1.5\text{ V}$		75	1000	ps	1

See "Single-ended Test Loads Page" for termination circuits

¹Guaranteed by design and characterization, not 100% tested in production.

²Measured between 0.8V and 2.0V

Clock AC Tolerances

	CPU	SRC, NS_SAS, NS_SRC	PCI	DOT96	48MHz	REF	
PPM tolerance	100	100	100	100	100	100	ppm
Cycle to Cycle Jitter	50	50	500	250	350	1000	ps
Spread	-0.50%	-0.50%	-0.50%	0	0.00%	0.00%	%

Clock Periods–Differential Outputs with Spread Spectrum Disabled

SSC ON	Center Freq. MHz	Measurement Window							Units	Notes
		1 Clock	1 us	0.1s	0.1s	0.1s	1us	1 Clock		
		-c2c jitter AbsPer Min	-SSC Short-Term Average Min	- ppm Long-Term Average Min	0 ppm Period Nominal	+ ppm Long-Term Average Max	+SSC Short-Term Average Max	+c2c jitter AbsPer Max		
CPU	100.00000	9.94900		9.99900	10.00000	10.00100		10.05100	ns	1,2
	133.33333	7.44925		7.49925	7.50000	7.50075		7.55075	ns	1,2
SRC, NS_SAS, NS_SRC	100.00000	9.94900		9.99900	10.00000	10.00100		10.05100	ns	1,2
PCI	33.33333	29.49700		29.99700	30.00000	30.00300		30.50300	ns	1,2
DOT96	96.00000	10.16563		10.41563	10.41667	10.41771		10.66771	ns	1,2
48MHz	48.00000	20.48125		20.83125	20.83333	20.83542		21.18542	ns	1,2
REF	14.31818	69.78429		69.83429	69.84128	69.84826		69.89826	ns	1,2

Clock Periods–Differential Outputs with Spread Spectrum Enabled

SSC ON	Center Freq. MHz	Measurement Window							Units	Notes
		1 Clock	1 us	0.1s	0.1s	0.1s	1us	1 Clock		
		-c2c jitter AbsPer Min	-SSC Short-Term Average Min	- ppm Long-Term Average Min	0 ppm Period Nominal	+ ppm Long-Term Average Max	+SSC Short-Term Average Max	+c2c jitter AbsPer Max		
CPU	99.75	9.94906	9.99906	10.02406	10.02506	10.02607	10.05107	10.10107	ns	1,2
	133.00	7.44930	7.49930	7.51805	7.51880	7.51955	7.53830	7.58830	ns	1,2
PCI	33.25	29.49718	29.99718	30.07218	30.07519	30.07820	30.15320	30.65320	ns	1,2
SRC	99.75	9.94906	9.99906	10.02406	10.02506	10.02607	10.05107	10.10107	ns	1,2

¹Guaranteed by design and characterization, not 100% tested in production.

²All Long Term Accuracy specifications are guaranteed with the assumption that the REF output is tuned to exactly 14.31818MHz.

General SMBus Serial Interface Information for 932SQ425

How to Write

- Controller (host) sends a start bit
- Controller (host) sends the write address
- IDT clock will **acknowledge**
- Controller (host) sends the beginning byte location = N
- IDT clock will **acknowledge**
- Controller (host) sends the byte count = X
- IDT clock will **acknowledge**
- Controller (host) starts sending Byte N through Byte N+X-1
- IDT clock will **acknowledge** each byte **one at a time**
- Controller (host) sends a Stop bit

Index Block Write Operation			
Controller (Host)			IDT (Slave/Receiver)
T	starT bit		
Slave Address			
WR	WRite		
Beginning Byte = N			ACK
			ACK
Data Byte Count = X			ACK
Beginning Byte N		X Byte	ACK
O			O
O			O
O			O
Byte N + X - 1			ACK
P	stoP bit		

Read Address	Write Address
D3 _(H)	D2 _(H)

How to Read

- Controller (host) will send a start bit
- Controller (host) sends the write address
- IDT clock will **acknowledge**
- Controller (host) sends the beginning byte location = N
- IDT clock will **acknowledge**
- Controller (host) will send a separate start bit
- Controller (host) sends the read address
- IDT clock will **acknowledge**
- IDT clock will send the data byte count = X
- IDT clock sends Byte N+X-1
- IDT clock sends **Byte 0 through Byte X (if X_(H) was written to Byte 8)**
- Controller (host) will need to acknowledge each byte
- Controller (host) will send a not acknowledge bit
- Controller (host) will send a stop bit

Index Block Read Operation			
Controller (Host)			IDT (Slave/Receiver)
T	starT bit		
Slave Address			
WR	WRite		
Beginning Byte = N			ACK
			ACK
RT	Repeat starT		
Slave Address			
RD	ReaD		
			ACK
ACK		X Byte	Data Byte Count=X
ACK			Beginning Byte N
O			O
O			O
O		O	
			Byte N + X - 1
N	Not acknowledge		
P	stoP bit		

SMBus Table: Output Enable Register

Byte 0	Pin #	Name	Control Function	Type	0	1	Default
Bit 7	14/15	DOT96 Enable	Output Enable	RW	Disable-Hi-Z	Enable	1
Bit 6	40/39	NS_SAS1 Enable	Output Enable	RW	Disable-Hi-Z	Enable	1
Bit 5	38/37	NS_SAS0 Enable	Output Enable	RW	Disable-Hi-Z	Enable	1
Bit 4	34/33	NS_SRC1 Enable	Output Enable	RW	Disable-Hi-Z	Enable	1
Bit 3	32/31	NS_SRC0 Enable	Output Enable	RW	Disable-Hi-Z	Enable	1
Bit 2	26/25	SRC1 Enable	Output Enable	RW	Disable-Hi-Z	Enable	1
Bit 1	24/23	SRC0 Enable	Output Enable	RW	Disable-Hi-Z	Enable	1
Bit 0			RESERVED				1

SMBus Table: Output Enable Register

Byte 1	Pin #	Name	Control Function	Type	0	1	Default
Bit 7	59	REF14_3x Enable	Output Enable	RW	Disable-Low	Enable	1
Bit 6			RESERVED				0
Bit 5			RESERVED				0
Bit 4			RESERVED				1
Bit 3	50/49	CPU2	Output Enable	RW	Disable-Hi-Z	Enable	1
Bit 2	46/45	CPU1	Output Enable	RW	Disable-Hi-Z	Enable	1
Bit 1	44/43	CPU0	Output Enable	RW	Disable-Hi-Z	Enable	1
Bit 0	CPU/SRC/ PCI	Spread Spectrum Enable	Spread Off/On	RW	Spread Off	Spread On	0

SMBus Table: Output Enable Register

Byte 2	Pin #	Name	Control Function	Type	0	1	Default
Bit 7			RESERVED				0
Bit 6			RESERVED				0
Bit 5			RESERVED				1
Bit 4			RESERVED				1
Bit 3	5	PCI2 Enable	Output Enable	RW	Disable-Low	Enable	1
Bit 2	6	PCI1 Enable	Output Enable	RW	Disable-Low	Enable	1
Bit 1	7	PCI0 Enable	Output Enable	RW	Disable-Low	Enable	1
Bit 0	11	48MHz Enable	Output Enable	RW	Disable-Low	Enable	1

SMBus Table: Reserved

Byte 3	Pin #	Name	Control Function	Type	0	1	Default
Bit 7			RESERVED				0
Bit 6			RESERVED				0
Bit 5			RESERVED				0
Bit 4			RESERVED				0
Bit 3			RESERVED				0
Bit 2			RESERVED				0
Bit 1			RESERVED				0
Bit 0			RESERVED				0

SMBus Table: Reserved

Byte 4	Pin #	Name	Control Function	Type	0	1	Default
Bit 7			RESERVED				0
Bit 6			RESERVED				0
Bit 5			RESERVED				0
Bit 4			RESERVED				0
Bit 3			RESERVED				0
Bit 2			RESERVED				0
Bit 1			RESERVED				0
Bit 0			RESERVED				0

SMBus Table: NS_SAS/NS_SRC Frequency Margining Table

Byte 5	Pin #	Name	Control Function	Type	0	1	Default
Bit 7			RESERVED				0
Bit 6			RESERVED				0
Bit 5			RESERVED				0
Bit 4	-	FS4	Freq. Sel 4	RW	See NS_SAS/NS_SRC Frequency Table.		0
Bit 3	-	FS3	Freq. Sel 3	RW		1	
Bit 2	-	FS2	Freq. Sel 2	RW		1	
Bit 1	-	FS1	Freq. Sel 1	RW		1	
Bit 0	-	FS0	Freq. Sel 0	RW		1	

SMBus Table: Test Mode and CPU/SRC/PCI Frequency Select Register

Byte 6	Pin #	Name	Control Function	Type	0	1	Default
Bit 7	-	Test Mode	Test Mode Type	RW	Hi-Z	REF/N	0
Bit 6	-	Test Select	Select Test Mode	RW	Disable	Enable	0
Bit 5	-		RESERVED				0
Bit 4	-	100M_133M# (See note)	Frequency Select	R	133MHz	100MHz	Latch
Bit 3	-	FS3	Freq. Sel 3	RW	See CPU/SRC/PCI Frequency Select Table		1
Bit 2	-	FS2	Freq. Sel 2	RW		0	
Bit 1	-	FS1	Freq. Sel 1	RW		0	
Bit 0	-	FS0	Freq. Sel 0	RW		0	

Note: Internal Pull up on 100M_133M# pin will result in default CPU frequency of 100 MHz.

SMBus Table: Vendor & Revision ID Register

Byte 7	Pin #	Name	Control Function	Type	0	1	Default
Bit 7	-	RID3	REVISION ID	R	0011 for A rev		0
Bit 6	-	RID2		R		0	
Bit 5	-	RID1		R		1	
Bit 4	-	RID0		R		1	
Bit 3	-	VID3	VENDOR ID	R	0001 for ICS/IDT		0
Bit 2	-	VID2		R		0	
Bit 1	-	VID1		R		0	
Bit 0	-	VID0		R		1	

SMBus Table: Byte Count Register

Byte 8	Pin #	Name	Control Function	Type	0	1	Default
Bit 7	-	BC7	Byte Count Programming b(7:0)	RW	Writing to this register will configure how many bytes will be read back, default is A bytes. (0 to 9)		0
Bit 6	-	BC6		RW		0	
Bit 5	-	BC5		RW		0	
Bit 4	-	BC4		RW		0	
Bit 3	-	BC3		RW		1	
Bit 2	-	BC2		RW		0	
Bit 1	-	BC1		RW		1	
Bit 0	-	BC0		RW		0	

SMBus Table: Device ID Register

Byte 9	Pin #	Name	Control Function	Type	0	1	Default
Bit 7		DID7	Device ID (17 hex)	R	-	-	0
Bit 6		DID6		R	-	-	0
Bit 5		DID5		R	-	-	0
Bit 4		DID4		R	-	-	1
Bit 3		DID3		R	-	-	0
Bit 2		DID2		R	-	-	1
Bit 1		DID1		R	-	-	1
Bit 0		DID0		R	-	-	1

CPU/SRC/PCI Frequency Selection Table

Line	Byte 1, Bit 0 Spread Enable	Byte6 Bit3 FS3	Byte6 Bit2 FS2	Byte6 Bit1 FS1	Byte6 Bit0 FS0	CPU Speed for 100MHz	CPU Speed for 133MHz	SRC (MHz)	PCI (MHz)	Spread %
0	0	0	0	0	0	89.97	119.97	89.97	29.99	0%
1	0	0	0	0	1	91.28	121.70	91.28	30.43	
2	0	0	0	1	0	92.58	123.44	92.58	30.86	
3	0	0	0	1	1	93.75	125.00	93.75	31.25	
4	0	0	1	0	0	95.05	126.73	95.05	31.68	
5	0	0	1	0	1	96.22	128.30	96.22	32.07	
6	0	0	1	1	0	97.53	130.03	97.53	32.51	
7	0	0	1	1	1	98.83	131.77	98.83	32.94	
8	0	1	0	0	0	100.00	133.33	100.00	33.33	
9	0	1	0	0	1	101.30	135.07	101.30	33.77	
10	0	1	0	1	0	102.47	136.63	102.47	34.16	
11	0	1	0	1	1	103.78	138.37	103.78	34.59	
12	0	1	1	0	0	105.08	140.10	105.08	35.03	
13	0	1	1	0	1	106.25	141.67	106.25	35.42	
14	0	1	1	1	0	107.55	143.40	107.55	35.85	
15	0	1	1	1	1	110.03	146.70	110.03	36.68	
16	1	0	0	0	0	89.97	119.97	89.97	29.99	-0.5%
17	1	0	0	0	1	91.28	121.70	91.28	30.43	
18	1	0	0	1	0	92.58	123.44	92.58	30.86	
19	1	0	0	1	1	93.75	125.00	93.75	31.25	
20	1	0	1	0	0	95.05	126.73	95.05	31.68	
21	1	0	1	0	1	96.22	128.30	96.22	32.07	
22	1	0	1	1	0	97.53	130.03	97.53	32.51	
23	1	0	1	1	1	98.83	131.77	98.83	32.94	
24	1	1	0	0	0	100.00	133.33	100.00	33.33	
25	1	1	0	0	1	101.30	135.07	101.30	33.77	
26	1	1	0	1	0	102.47	136.63	102.47	34.16	
27	1	1	0	1	1	103.78	138.37	103.78	34.59	
28	1	1	1	0	0	105.08	140.10	105.08	35.03	
29	1	1	1	0	1	106.25	141.67	106.25	35.42	
30	1	1	1	1	0	107.55	143.40	107.55	35.85	
31	1	1	1	1	1	110.03	146.70	110.03	36.68	

NS_SAS Margining Table

Line	Byte5 Bit4 FS4	Byte5 Bit3 FS3	Byte5 Bit2 FS2	Byte5 Bit1 FS1	Byte5 Bit0 FS0	NS_xxx (MHz)
0	0	0	0	0	0	61.05
1	0	0	0	0	1	61.11
2	0	0	0	1	0	63.89
3	0	0	0	1	1	66.67
4	0	0	1	0	0	69.44
5	0	0	1	0	1	72.22
6	0	0	1	1	0	75.00
7	0	0	1	1	1	77.78
8	0	1	0	0	0	80.56
9	0	1	0	0	1	83.33
10	0	1	0	1	0	86.11
11	0	1	0	1	1	88.89
12	0	1	1	0	0	91.67
13	0	1	1	0	1	94.44
14	0	1	1	1	0	97.22
15	0	1	1	1	1	100.00
16	1	0	0	0	0	102.78
17	1	0	0	0	1	105.56
18	1	0	0	1	0	108.33
19	1	0	0	1	1	111.11
20	1	0	1	0	0	113.89
21	1	0	1	0	1	116.67
22	1	0	1	1	0	119.44
23	1	0	1	1	1	122.22
24	1	1	0	0	0	125.00
25	1	1	0	0	1	127.78
26	1	1	0	1	0	130.56
27	1	1	0	1	1	133.33
28	1	1	1	0	0	136.11
29	1	1	1	0	1	138.89
30	1	1	1	1	0	141.67
31	1	1	1	1	1	144.44

NOTE: Operation at other than the default entry is not guaranteed. These values are for margining purposes only.

DIF Reference Clock			
Common Recommendations for Differential Routing	Dimension or Value	Unit	Figure
L1 length, route as non-coupled 50ohm trace	0.5 max	inch	1
L2 length, route as non-coupled 50ohm trace	0.2 max	inch	1
L3 length, route as non-coupled 50ohm trace	0.2 max	inch	1
Rs	33	ohm	1
Rt	49.9	ohm	1

Down Device Differential Routing			
L4 length, route as coupled microstrip 100ohm differential trace	2 min to 16 max	inch	1
L4 length, route as coupled stripline 100ohm differential trace	1.8 min to 14.4 max	inch	1

Differential Routing to PCI Express Connector			
L4 length, route as coupled microstrip 100ohm differential trace	0.25 to 14 max	inch	2
L4 length, route as coupled stripline 100ohm differential trace	0.225 min to 12.6 max	inch	2

Figure 1: Down Device Routing

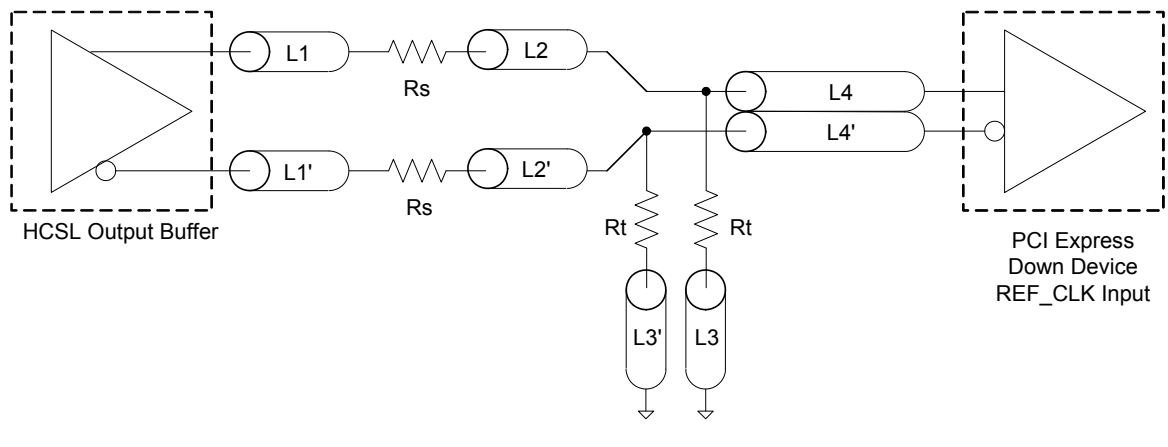
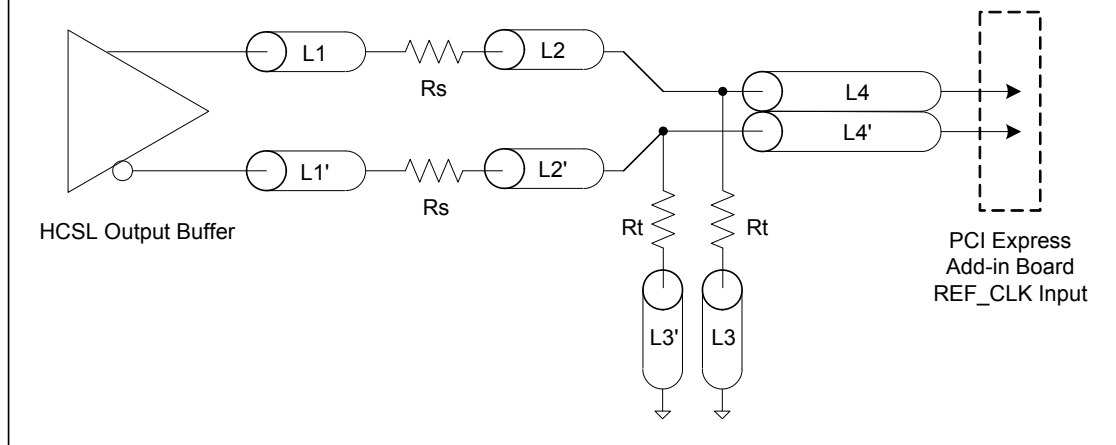
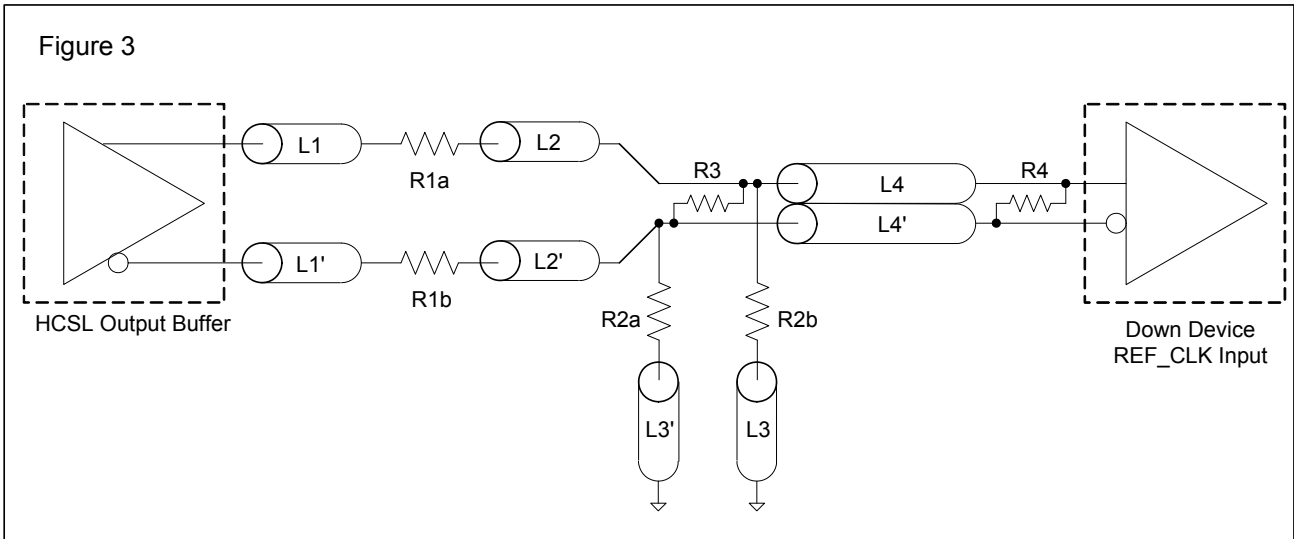

Figure 2: Differential Routing to PCI Express Controller



Alternative Termination for LVDS and other Common Differential Signals (figure 3)							
Vdiff	Vp-p	Vcm	R1	R2	R3	R4	Note
0.45v	0.22v	1.08	33	150	100	100	
0.58	0.28	0.6	33	78.7	137	100	
0.80	0.40	0.6	33	78.7	none	100	ICS874003i-02 input compatible
0.60	0.3	1.2	33	174	140	100	Standard LVDS

R1a = R1b = R1
R2a = R2b = R2



Cable Connected AC Coupled Application (figure 4)		
Component	Value	Note
R5a, R5b	8.2K 5%	
R6a, R6b	1K 5%	
Cc	0.1 μF	
Vcm	0.350 volts	

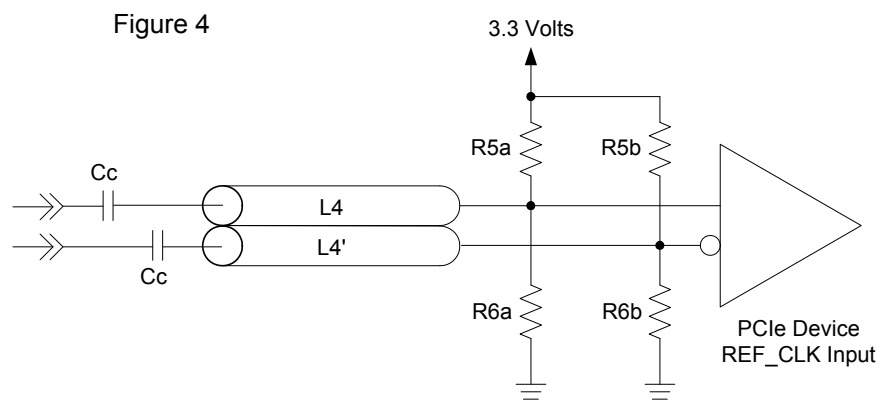

Test Clarification Table

Comments	HW		SW		OUTPUT
	TEST_SEL HW PIN	TEST_MODE HW PIN	TEST ENTRY BIT B6b6	REF/N or HI-Z B6b7	
	0	X	0	X	NORMAL
Power-up w/ TEST_SEL = 1 (>2.0V) to enter test mode. Cycle power to disable test mode.	1	0	X	0	HI-Z
	1	0	X	1	REF/N
	1	1	X	0	REF/N
	1	1	X	1	REF/N
If TEST_SEL HW pin is 0 during power-up, test mode can be selected through B6b6. If test mode is selected by B6b6, then B6b7 is used to select HI-Z or REF/N. TEST_Mode pin is not used. Cycle power to disable test mode.	0	X	1	0	HI-Z
	0	X	1	1	REF/N

B6b6: 1= ENTER TEST MODE, Default = 0 (NORMAL OPERATION)

B6b7: 1= REF/N, Default = 0 (HI-Z)

Marking Diagram



Notes:

1. ##### is the lot number.
2. YYWW is the last two digits of the year and week that the part was assembled.
3. "L" denotes RoHS compliant package.
4. 'CofO' is the country of origin.

Package Outline and Package Dimensions (56-pin MLF)

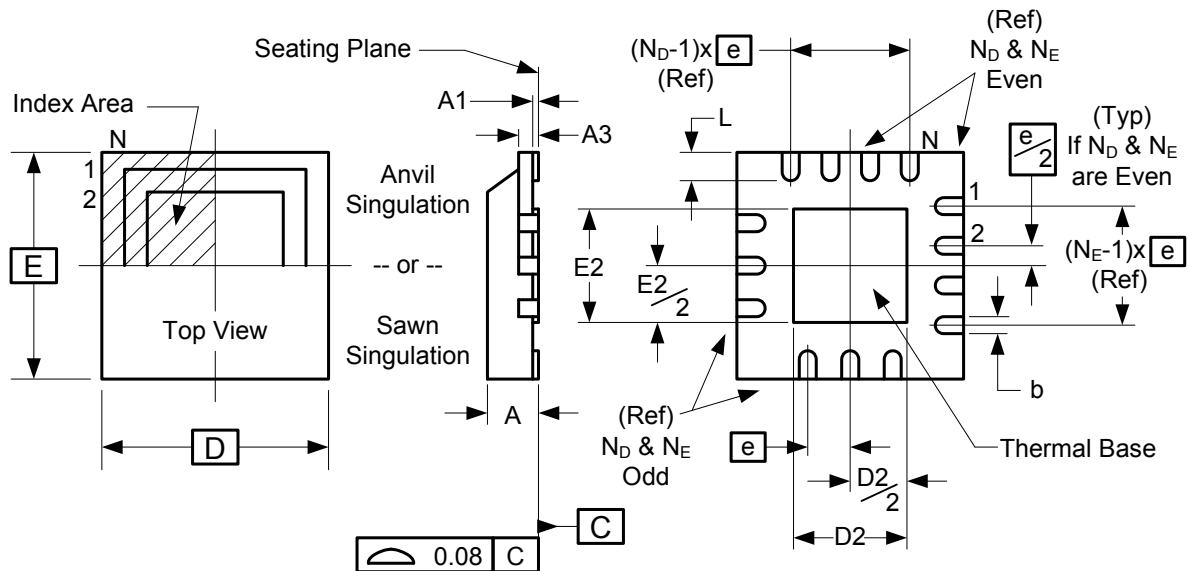

Symbol	Millimeters	
	Min	Max
A	0.8	1.0
A1	0	0.05
A3	0.25 Reference	
b	0.18	0.3
e	0.50 BASIC	
D x E BASIC	8.00 x 8.00	
D2 MIN./MAX.	4.35	4.65
E2 MIN./MAX.	5.05	5.35
L MIN./MAX.	0.30	0.50
N	56	
N _D	14	
N _E	14	

Ordering Information

Part / Order Number	Marking	Shipping Packaging	Package	Temperature
932SQ425AKLF	see page 19	Trays	56-pin MLF	0 to +70° C
932SQ425AKLFT		Tape and Reel	56-pin MLF	0 to +70° C

"LF" suffix to the part number are the Pb-Free configuration and are RoHS compliant.

"A" is the device revision designator (will not correlate with the datasheet revision).

While the information presented herein has been checked for both accuracy and reliability, Integrated Device Technology (IDT) assumes no responsibility for either its use or for the infringement of any patents or other rights of third parties, which would result from its use. No other circuits, patents, or licenses are implied. This product is intended for use in normal commercial applications. Any other applications such as those requiring extended temperature range, high reliability, or other extraordinary environmental requirements are not recommended without additional processing by IDT. IDT reserves the right to change any circuitry or specifications without notice. IDT does not authorize or warrant any IDT product for use in life support devices or critical medical instruments.

Revision History

Rev.	Issue Date	Who	Description	Page #
A	12/8/2011	RDW	1. Updated Phase Jitter Table to correct typo in "Conditions" column for SAS. 2. Mark spec added 3. Move to final	8, 19
B	4/23/2012	RDW	1. Updated Rp values on Output Terminations Table from 43.2 ohms to 42.2 or 43.2 ohms to be consistent with Intel.	5

IMPORTANT NOTICE AND DISCLAIMER

RENESAS ELECTRONICS CORPORATION AND ITS SUBSIDIARIES (“RENESAS”) PROVIDES TECHNICAL SPECIFICATIONS AND RELIABILITY DATA (INCLUDING DATASHEETS), DESIGN RESOURCES (INCLUDING REFERENCE DESIGNS), APPLICATION OR OTHER DESIGN ADVICE, WEB TOOLS, SAFETY INFORMATION, AND OTHER RESOURCES “AS IS” AND WITH ALL FAULTS, AND DISCLAIMS ALL WARRANTIES, EXPRESS OR IMPLIED, INCLUDING, WITHOUT LIMITATION, ANY IMPLIED WARRANTIES OF MERCHANTABILITY, FITNESS FOR A PARTICULAR PURPOSE, OR NON-INFRINGEMENT OF THIRD-PARTY INTELLECTUAL PROPERTY RIGHTS.

These resources are intended for developers who are designing with Renesas products. You are solely responsible for (1) selecting the appropriate products for your application, (2) designing, validating, and testing your application, and (3) ensuring your application meets applicable standards, and any other safety, security, or other requirements. These resources are subject to change without notice. Renesas grants you permission to use these resources only to develop an application that uses Renesas products. Other reproduction or use of these resources is strictly prohibited. No license is granted to any other Renesas intellectual property or to any third-party intellectual property. Renesas disclaims responsibility for, and you will fully indemnify Renesas and its representatives against, any claims, damages, costs, losses, or liabilities arising from your use of these resources. Renesas' products are provided only subject to Renesas' Terms and Conditions of Sale or other applicable terms agreed to in writing. No use of any Renesas resources expands or otherwise alters any applicable warranties or warranty disclaimers for these products.

(Disclaimer Rev.1.01 Jan 2024)

Corporate Headquarters

TOYOSU FORESIA, 3-2-24 Toyosu,
Koto-ku, Tokyo 135-0061, Japan
www.renesas.com

Trademarks

Renesas and the Renesas logo are trademarks of Renesas Electronics Corporation. All trademarks and registered trademarks are the property of their respective owners.

Contact Information

For further information on a product, technology, the most up-to-date version of a document, or your nearest sales office, please visit www.renesas.com/contact-us/.

Looking for pricing, stock, or lifecycle information?

Click below to explore more details on WIN SOURCE:

-  [View 932SQ425AKLF](#) on WIN SOURCE
-  [Renesas Electronics America](#) Information

Optimize Your Supply Chain with WIN SOURCE Solutions

-  Global Sourcing Solution
-  Obsolete Management
-  Cost Control Management
-  Shortage Management
-  Alternative Solution
-  Excess Inventory Management