



**THE DATASHEET OF  
8V41N004NLGI**



### General Description

The IDT8V41N004I is a clock generator designed for Gigabit Ethernet, 10 Gigabit Ethernet, SGMII and PCI Express™ applications. The device generates a selectable 100MHz, 125MHz, 156.25MHz or 312.5MHz clock signal from 25MHz input. The IDT8V41N004I uses IDT's fourth generation FemtoClock®NG technology to provide low phase noise performance, combined with excellent power supply noise rejection for optimal performance in the targeted applications. The device supports a 3.3V supply voltage and is packaged in a compact, lead-free (RoHS 6) 32-lead VFQFN package. The industrial temperature range supports high end computing, telecommunication and networking end equipment requirements.

### Features

- Fourth generation FemtoClock® NG technology
- Four 100MHz, 125MHz, 156.25MHz and 312.5MHz clocks for Gigabit Ethernet, 10 Gigabit Ethernet, SGMII and PCI Express applications, HCSL interface levels
- Selectable external crystal or differential input source
- Crystal oscillator interface designed for 25MHz parallel resonant crystal
- Differential CLK, nCLK input pair accepts LVPECL, LVDS, LVHSTL, HCSL input levels
- Internal resistor bias on nCLK pin allows the user to drive CLK input with external single-ended (LVCMOS/ LVTTTL) input levels
- PCI Express Gen1, Gen2, and Gen3 compliant
- RMS phase jitter 156.25MHz (12kHz - 20MHz): 0.217ps
- Full 3.3V supply voltage
- -40°C to 85°C ambient operating temperature

### Pin Assignment

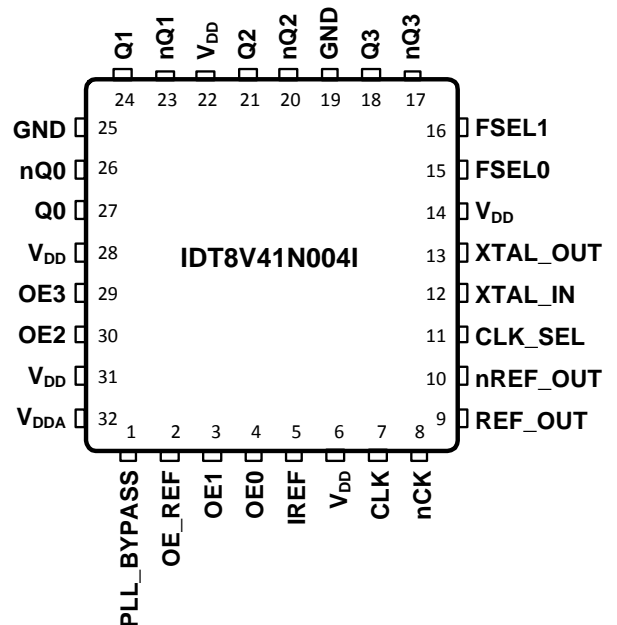

**32 Lead VFQFN**  
**5mm x 5mm x 0.925mm Package Body**  
**3.15mm x 3.15mm EPad Size**  
**NL Package**  
**Top View**

# Block Diagram

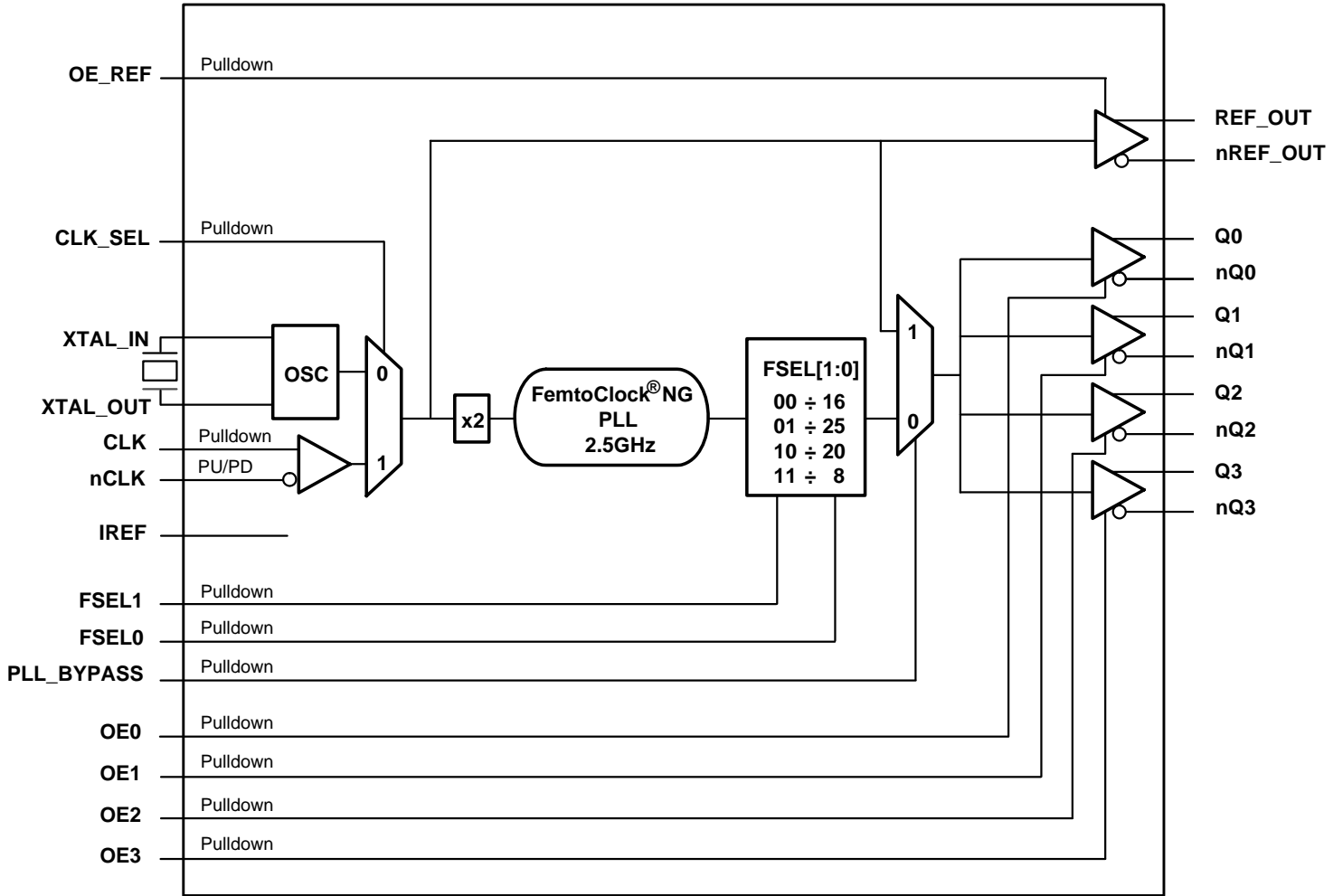

## Pin Description and Pin Characteristic Tables

Table 1. Pin Descriptions

Number	Name	Type		Description
1	PLL_BYPASS	Input	Pulldown	Active HIGH PLL bypass. LVCMOS/LVTTL interface levels. PLL_BYPASS = 0: PLL mode (default) PLL_BYPASS = 1: Bypass mode
2	OE_REF	Input	Pulldown	Active HIGH output enable for REF_OUT, nREF_OUT differential output. LVCMOS/LVTTL interface levels. OE_REF = 0: Output REF_OUT disabled/high Impedance (default) OE_REF = 1: Output REF_OUT enabled
3	OE1	Input	Pulldown	Active HIGH output enable for Q1, nQ1 differential output. LVCMOS/LVTTL interface levels. OE1 = 0: Output Q1 disabled/high impedance (default) OE1 = 1: Output Q1 enabled
4	OE0	Input	Pulldown	Active HIGH output enable for Q0, nQ0 differential output. LVCMOS/LVTTL interface levels. OE0 = 0: Output Q0 disabled/high impedance (default) OE0 = 1: Output Q0 enabled
5	IREF	Input		External fixed precision resistor (475Ω) from this pin to ground provides a reference current used for HCSL outputs.
6, 14, 22, 28, 31	V <sub>DD</sub>	Power		Supply voltage pins.
7	CLK	Input	Pulldown	Non-inverting differential clock input.
8	nCLK	Input	Pullup/ Pulldown	Inverting differential clock input. V <sub>DD</sub> /2 default when left floating.
9, 10	REF_OUT, nREF_OUT	Output		Differential reference clock output pair. HCSL interface levels.
11	CLK_SEL	Input	Pulldown	Active HIGH clock select input. Selects PLL input source. LVCMOS /LVTTL interface levels. CLK_SEL = 0: XTAL_IN, XTAL_OUT (default) CLK_SEL = 1: CLK, nCLK
12, 13	XTAL_IN, XTAL_OUT	Input		Crystal oscillator interface. XTAL_IN is the input., XTAL_OUT is the output.
15, 16	FSEL0, FSEL1	Input	Pulldown	Output frequency select pins. LVCMOS/LVTTL interface levels. FSEL[1:0] = 00: F <sub>OUT</sub> = 156.25MHz (default) FSEL[1:0] = 01: F <sub>OUT</sub> = 100MHz FSEL[1:0] = 10: F <sub>OUT</sub> = 125MHz FSEL[1:0] = 11: F <sub>OUT</sub> = 312.5MHz
17, 18	nQ3, Q3	Output		Differential output pair. HCSL interface levels.
19, 25	GND	Power		Power supply ground.
20, 21	nQ2, Q2	Output		Differential output pair. HCSL interface levels.
23, 24	nQ1, Q1	Output		Differential output pair. HCSL interface levels.
26, 27	nQ0, Q0	Output		Differential output pair. HCSL interface levels.
29	OE3	Input	Pulldown	Active HIGH output enable for Q3, nQ3 differential output. LVCMOS/LVTTL interface levels. OE3 = 0: Output Q3 disabled/high impedance (default) OE3 = 1: Output Q3 enabled
30	OE2	Input	Pulldown	Active HIGH output enable for Q2, nQ2 differential output. LVCMOS/LVTTL interface levels. OE2 = 0: Output Q2 disabled/high impedance (default) OE2 = 1: Output Q2 enabled
32	V <sub>DDA</sub>	Power		Analog supply voltage.

NOTE: Pullup and Pulldown refer to internal input resistors. See Table 2, Pin Characteristics, for typical values.

**Table 2. Pin Characteristics**

Symbol	Parameter	Test Conditions	Minimum	Typical	Maximum	Units
$C_{IN}$	Input Capacitance			3.5		pF
$R_{PULLUP}$	Input Pullup Resistor			51		$K\Omega$
$R_{PULLDOWN}$	Input Pulldown Resistor			51		$K\Omega$

## Absolute Maximum Ratings

NOTE: Stresses beyond those listed under *Absolute Maximum Ratings* may cause permanent damage to the device. These ratings are stress specifications only. Functional operation of product at these conditions or any conditions beyond those listed in the *DC Characteristics* or *AC Characteristics* is not implied. Exposure to absolute maximum rating conditions for extended periods may affect product reliability.

Item	Rating
Supply Voltage, $V_{DD}$	3.6V
Inputs, $V_I$ XTAL_IN Other Inputs	0V to 2V -0.5V to $V_{DD} + 0.5V$
Outputs, $V_O$	-0.5V to $V_{DD} + 0.5V$
Package Thermal Impedance, $\theta_{JA}$	33.1°C/W (0 mps)
Storage Temperature, $T_{STG}$	-65°C to 150°C

## DC Electrical Characteristics

**Table 3A. Power Supply DC Characteristics,  $V_{DD} = 3.3V \pm 5\%$ ,  $T_A = -40^\circ C$  to  $85^\circ C$** 

Symbol	Parameter	Test Conditions	Minimum	Typical	Maximum	Units
$V_{DD}$	Core Supply Voltage		3.135	3.3	3.465	V
$V_{DDA}$ ; NOTE 1	Analog Supply Voltage		$V_{DD} - 0.155$	3.3	$V_{DD}$	V
$I_{DD}$	Power Supply Current	Outputs Disabled			121	mA
$I_{DDA}$	Analog Supply Current				31	mA

NOTE 1: This device requires that  $V_{DD}$  and  $V_{DDA}$  are powered simultaneously. See *Power Supply Sequence Requirement* application note.

**Table 3B. LVCMOS/LVTTL DC Characteristics,  $V_{DD} = 3.3V \pm 5\%$ ,  $T_A = -40^\circ C$  to  $85^\circ C$** 

Symbol	Parameter		Test Conditions	Minimum	Typical	Maximum	Units
$V_{IH}$	Input High Voltage			2		$V_{DD} + 0.3$	V
$V_{IL}$	Input Low Voltage			-0.3		0.8	V
$I_{IH}$	Input High Current	FSEL[1:0], CLK_SEL, OE_REF, PLL_BYPASS, OE0, OE1, OE2, OE3	$V_{DD} = V_{IN} = 3.465V$			150	$\mu A$
$I_{IL}$	Input Low Current	FSEL[1:0], CLK_SEL, OE_REF, PLL_BYPASS, OE0, OE1, OE2, OE3	$V_{DD} = 3.465V, V_{IN} = 0V$	-5			$\mu A$

**Table 3C. Differential DC Characteristics,  $V_{DD} = 3.3V \pm 5\%$ ,  $T_A = -40^\circ C$  to  $85^\circ C$** 

Symbol	Parameter		Test Conditions	Minimum	Typical	Maximum	Units
$I_{IH}$	Input High Current	CLK, nCLK	$V_{DD} = V_{IN} = 3.465V$			150	$\mu A$
$I_{IL}$	Input Low Current	CLK	$V_{DD} = 3.465V, V_{IN} = 0V$	-5			$\mu A$
		nCLK	$V_{DD} = 3.465V, V_{IN} = 0V$	-150			$\mu A$
$V_{PP}$	Peak-to-Peak Input Voltage			0.15		1.3	V
$V_{CMR}$	Common Mode Input Voltage; NOTE 1			GND + 0.5		$V_{DD} - 0.85$	V

NOTE 1: Common mode voltage is defined as the crosspoint.

**Table 4. Crystal Characteristics**

Parameter	Test Conditions	Minimum	Typical	Maximum	Units
Mode of Oscillation		Fundamental			
Frequency			25		MHz
Load Capacitance ( $C_L$ )			12		pF
Equivalent Series Resistance (ESR)				50	$\Omega$
Shunt Capacitance				7	pF

NOTE: Characterized using a 12pF parallel resonant crystal.

**Table 5. Input Frequency Characteristics,  $V_{DD} = 3.3V \pm 5\%$ ,  $T_A = -40^\circ C$  to  $85^\circ C$** 

Symbol	Parameter		Test Conditions	Minimum	Typical	Maximum	Units
$f_{IN}$	Input Frequency	XTAL_IN, XTAL_OUT			25		MHz
		CLK, nCLK			25		MHz
$f_{IN\_DC}$	Input Duty Cycle	CLK, nCLK		45		55	%

## AC Electrical Characteristics

**Table 6A. PCI Express Jitter Specifications,  $V_{DD} = 3.3V \pm 5\%$ ,  $T_A = -40^{\circ}C$  to  $85^{\circ}C$**

Symbol	Parameter	Test Conditions	Minimum	Typical	Maximum	PCIe Industry Specification	Units
$t_j$ (PCIe Gen 1)	Phase Jitter Peak-to-Peak; NOTE 1, 4	$f = 100MHz$ , 25MHz Crystal Input Evaluation Band: 0Hz - Nyquist (clock frequency/2)		11	18	86	ps
$t_{REFCLK\_HF\_RMS}$ (PCIe Gen 2)	Phase Jitter RMS; NOTE 2, 4	$f = 100MHz$ , 25MHz Crystal Input High Band: 1.5MHz - Nyquist (clock frequency/2)		1.0	1.6	3.10	ps
$t_{REFCLK\_LF\_RMS}$ (PCIe Gen 2)	Phase Jitter RMS; NOTE 2, 4	$f = 100MHz$ , 25MHz Crystal Input Low Band: 10kHz - 1.5MHz		0.24	1.1	3.0	ps
$t_{REFCLK\_RMS}$ (PCIe Gen 3)	Phase Jitter RMS; NOTE 3, 4	$f = 100MHz$ , 25MHz Crystal Input Evaluation Band: 0Hz - Nyquist (clock frequency/2)		0.24	0.41	0.8	ps

NOTE: Electrical parameters are guaranteed over the specified ambient operating temperature range, which is established when the device is mounted in a test socket with maintained transverse airflow greater than 500 lfm. The device will meet specifications after thermal equilibrium has been reached under these conditions. For additional information, refer to the *PCI Express Application Note section* in the datasheet.

NOTE 1: Peak-to-Peak jitter after applying system transfer function for the Common Clock Architecture. Maximum limit for PCI Express Gen 1 is 86ps peak-to-peak for a sample size of  $10^6$  clock periods.

NOTE 2: RMS jitter after applying the two evaluation bands to the two transfer functions defined in the Common Clock Architecture and reporting the worst case results for each evaluation band. Maximum limit for PCI Express Generation 2 is 3.1ps RMS for  $t_{REFCLK\_HF\_RMS}$  (High Band) and 3.0ps RMS for  $t_{REFCLK\_LF\_RMS}$  (Low Band).

NOTE 3: RMS jitter after applying system transfer function for the common clock architecture. This specification is based on the *PCI Express Base Specification Revision 0.7, October 2009* and is subject to change pending the final release version of the specification.

NOTE 4: This parameter is guaranteed by characterization. Not tested in production.

**Table 6B. AC Characteristics,  $V_{DD} = 3.3V \pm 5\%$ ,  $T_A = -40^\circ C$  to  $85^\circ C$** 

Symbol	Parameter	Test Conditions	Minimum	Typical	Maximum	Units
$f_{OUT}$	Output Frequency	Q[0:3], nQ[0:3]	FSEL[1:0] = 00	156.25		MHz
		Q[0:3], nQ[0:3]	FSEL[1:0] = 01	100		MHz
		Q[0:3], nQ[0:3]	FSEL[1:0] = 10	125		MHz
		Q[0:3], nQ[0:3]	FSEL[1:0] = 11	312.5		MHz
		REF_OUT	XTAL, CLK, nCLK = 25MHz	25		MHz
$\Phi_N(100)$	Single-Side Band Noise Power, 100Hz from Carrier	25MHz Crystal Input, $f_{OUT} = 156.25MHz$		-85		dBc/Hz
$\Phi_N(1k)$	Single-Side Band Noise Power, 1kHz from Carrier	25MHz Crystal Input, $f_{OUT} = 156.25MHz$		-118		dBc/Hz
$\Phi_N(10k)$	Single-Side Band Noise Power, 10kHz from Carrier	25MHz Crystal Input, $f_{OUT} = 156.25MHz$		-133		dBc/Hz
$\Phi_N(100k)$	Single-Side Band Noise Power, 100kHz from Carrier	25MHz Crystal Input, $f_{OUT} = 156.25MHz$		-138		dBc/Hz
$\Phi_N(1M)$	Single-Side Band Noise Power, 1MHz from Carrier	25MHz Crystal Input, $f_{OUT} = 156.25MHz$		-143		dBc/Hz
$\Phi_N(10M)$	Single-Side Band Noise Power, 10MHz from Carrier	25MHz Crystal Input, $f_{OUT} = 156.25MHz$		-156		dBc/Hz
$t_{jit}(\emptyset)$	RMS Phase Jitter (Random); NOTE 1, 2	100MHz, Integration Range (12kHz to 20MHz)		0.219		ps
		125MHz, Integration Range: 12kHz – 20MHz		0.205		ps
		156.25MHz, Integration Range: 12kHz – 20MHz		0.217		ps
		312.5MHz, Integration Range: 12kHz – 20MHz		0.215		ps
$t_{REF\_OUT\_RMS}$	Phase Jitter RMS; NOTE 1	25MHz crystal input Integration Range: 12kHz - 5MHz		0.268		ps
$t_{sk(o)}$	Output Skew; NOTE 3, 4	Q[0:3], nQ[0:3]			100	ps
$f_{jit(cc)}$	Cycle-to-Cycle Jitter; NOTE 3	PLL Mode		12		ps
$f_{jit(per)}$	Period Jitter, RMS; NOTE 3	PLL Mode		3.8		ps
$t_L$	PLL Lock Time				30	ms
$V_{MAX}$	Absolute Max. Output Voltage; NOTE 5, 6				1150	mV
$V_{MIN}$	Absolute Min. Output Voltage; NOTE 5, 7		-300			mV
$V_{RB}$	Ringback Voltage; NOTE 8, 9		-100		100	mV
$t_{STABLE}$	Time before $V_{RB}$ is Allowed; NOTE 8, 9		500			ps

Symbol	Parameter	Test Conditions	Minimum	Typical	Maximum	Units
$V_{\text{CROSS}}$	Absolute Crossing Voltage; NOTE 5, 10, 11	$f_{\text{OUT}} = 100\text{MHz}$	230		550	mV
$\Delta V_{\text{CROSS}}$	Total Variation of $V_{\text{CROSS}}$ Over all Edges; NOTE 5, 10, 12				140	mV
PSNR	Power Supply Noise Rejection			45		dB
$t_{\text{SLEW+}}$	Rising Edge Rate; NOTE 8, 13		0.6		4.0	V/ns
$t_{\text{SLEW-}}$	Falling Edge Rate; NOTE 8, 13		0.6		4.0	V/ns
odc	Output Duty Cycle; NOTE 8	Q[0:3], nQ[0:3] 25MHz Crystal Input	45		55	%

NOTE: Electrical parameters are guaranteed over the specified ambient operating temperature range, which is established when the device is mounted in a test socket with maintained transverse airflow greater than 500 lpm. The device will meet specifications after thermal equilibrium has been reached under these conditions.

NOTE 1: Refer to Phase Noise Plot section.

NOTE 2: REF\_OUT, nREF\_OUT is disabled.

NOTE 3: This parameter is defined in accordance with JEDEC Standard 65.

NOTE 4: Defined as skew between outputs at the same supply voltage and with equal load conditions. Measured at the output differential cross points.

NOTE 5: Measurement taken from a single ended waveform.

NOTE 6: Defined as the maximum instantaneous voltage including overshoot. See Parameter Measurement Information Section.

NOTE 7: Defined as the minimum instantaneous voltage including undershoot. See Parameter Measurement Information Section.

NOTE 8: Measurement taken from a differential waveform.

NOTE 9:  $T_{\text{STABLE}}$  is the time the differential clock must maintain a minimum  $\pm 150\text{mV}$  differential voltage after rising/falling edges before it is allowed to drop back into the  $V_{\text{RB}} \pm 100\text{mV}$  differential range.

NOTE 10: Measured at crossing point where the instantaneous voltage value of the rising edge of Qx+ equals the falling edge of Qx-.

NOTE 11: Refers to the total variation from the lowest crossing point to the highest, regardless of which edge is crossing. Refers to all crossing points for this measurement.

NOTE 12: Defined as the total variation of all crossing voltages of rising Qx+ and falling Qx-, This is the maximum allowed variance in  $V_{\text{cross}}$  for any particular system. See Parameter Measurement Information Section.

NOTE 13: Measured from  $-150\text{mV}$  to  $+150\text{mV}$  on the differential waveform (derived from Q minus nQ). The signal must be monotonic through the measurement region for rise and fall time. The  $300\text{mV}$  measurement window is centered on the differential zero crossing.

### Typical Phase Noise at 156.25MHz

Phase Noise 10.00dB/Ref -20.00dBc/Hz [Smo]

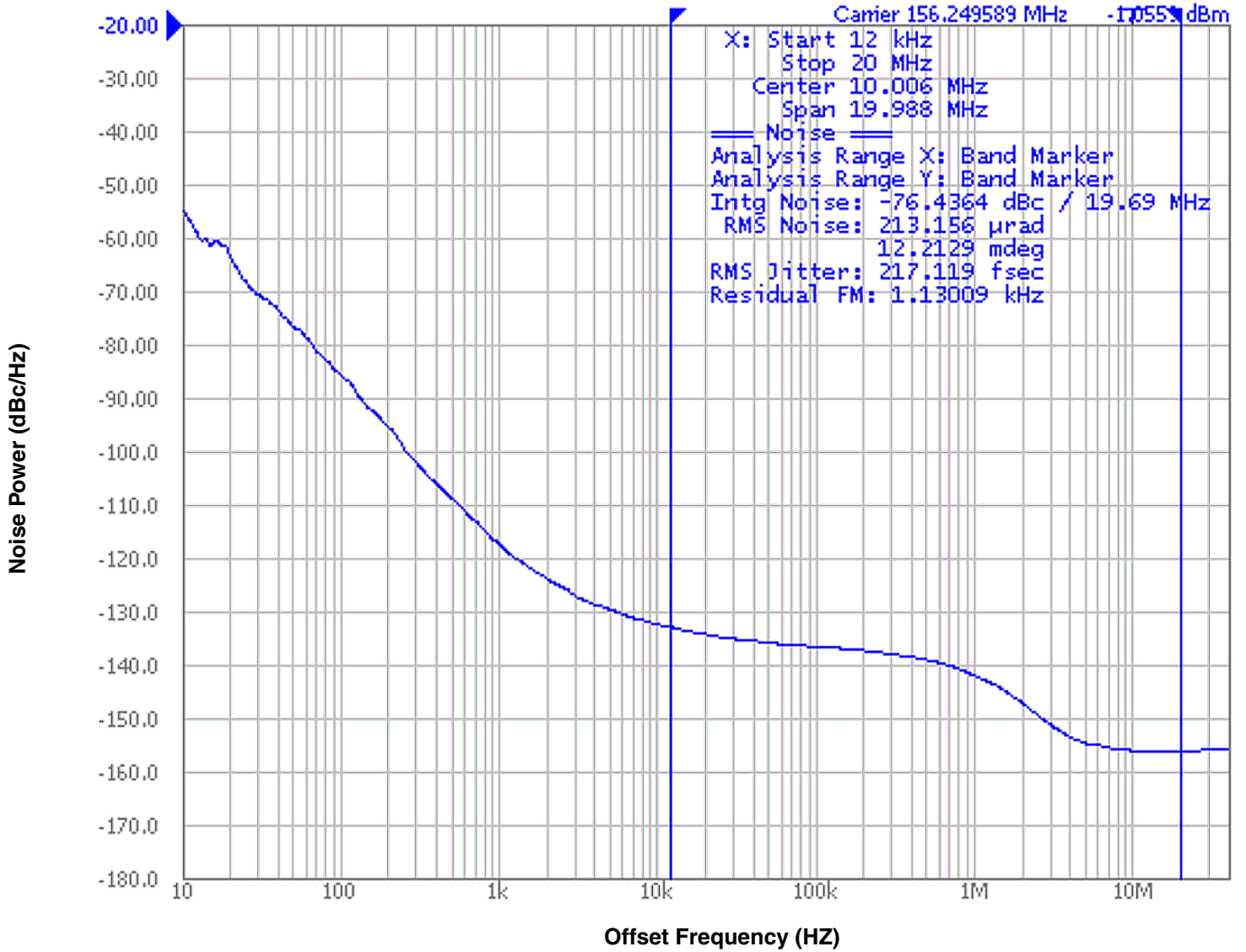

Typical Phase Noise at 25MHz (REF\_OUT, nREF\_OUT)

Phase Noise 10.00dB/ Ref -20.00dBc/Hz [Smo]

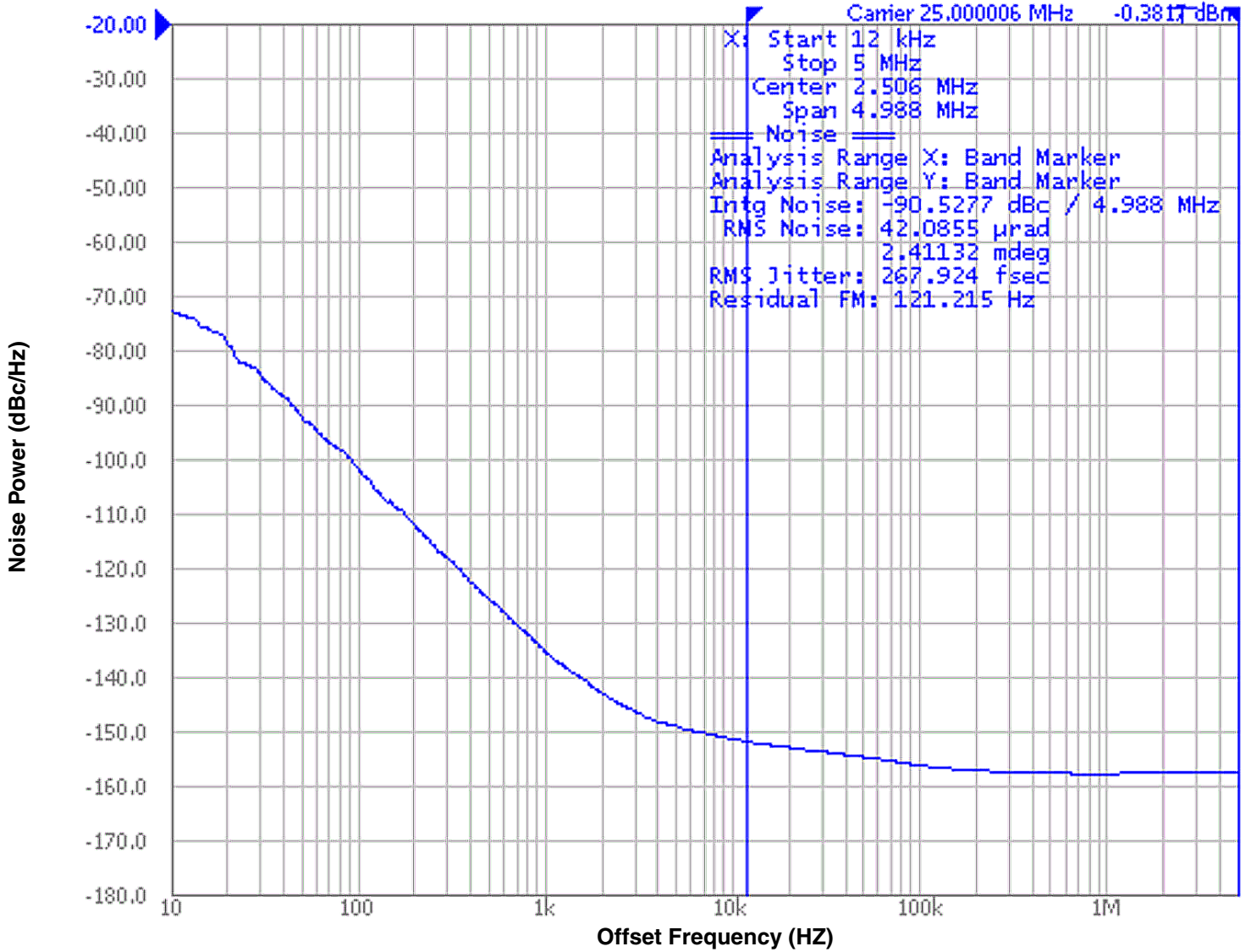

## Parameter Measurement Information

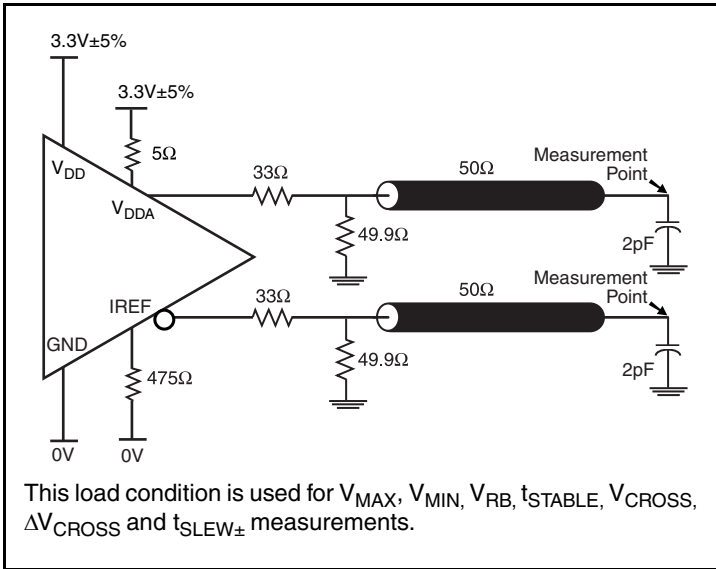

3.3V HCSL Output Load Test Circuit 1

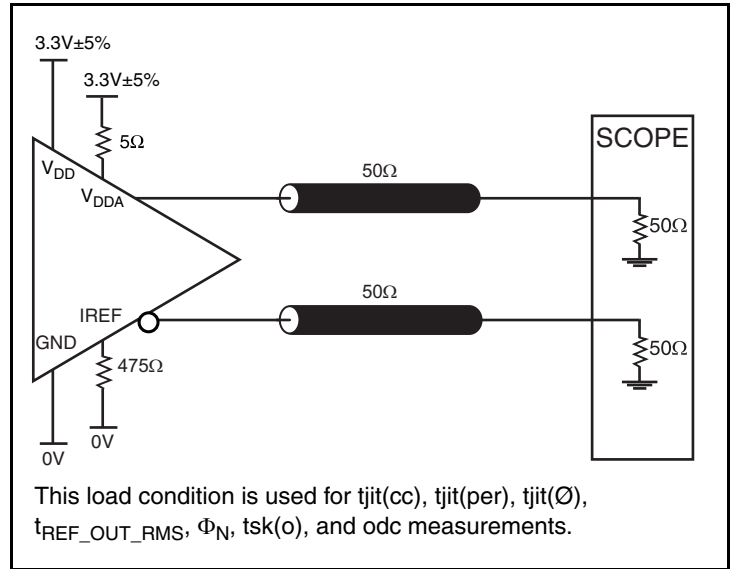

3.3V HCSL Output Load Test Circuit 2

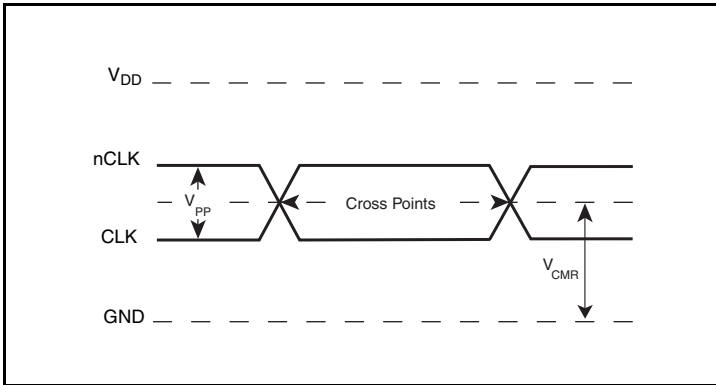

Differential Input Level

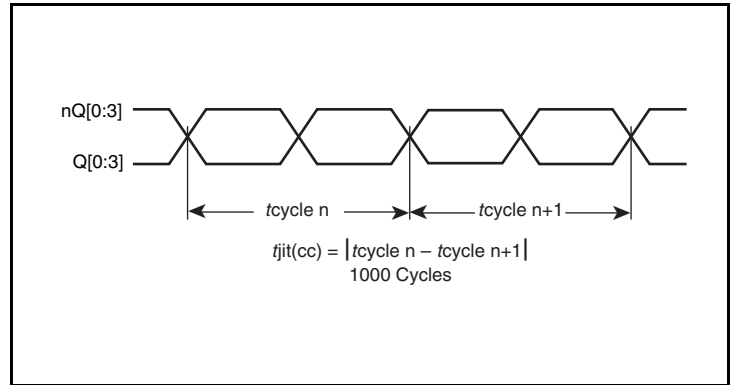

Cycle-to-Cycle Jitter

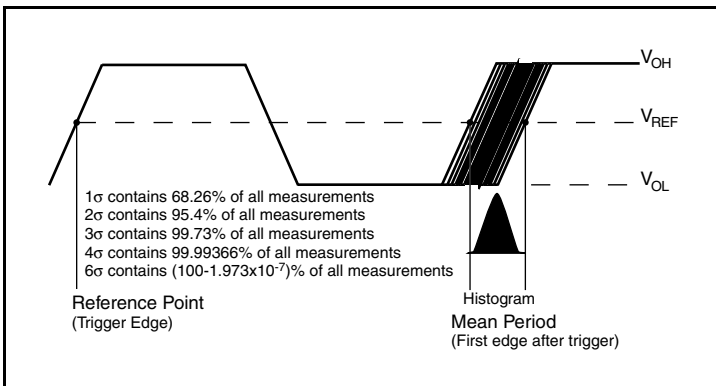

Period Jitter

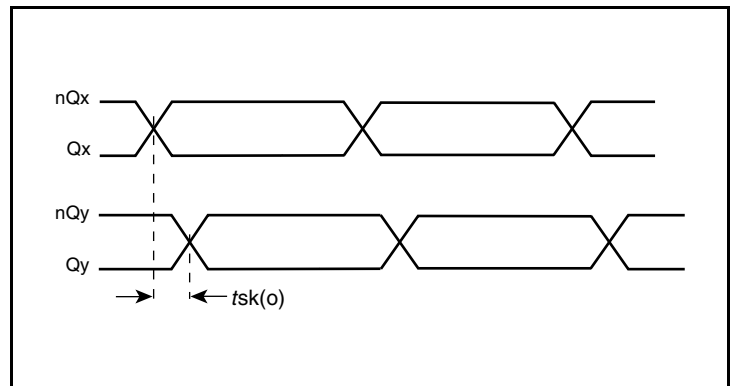

Output Skew

## Parameter Measurement Information, continued

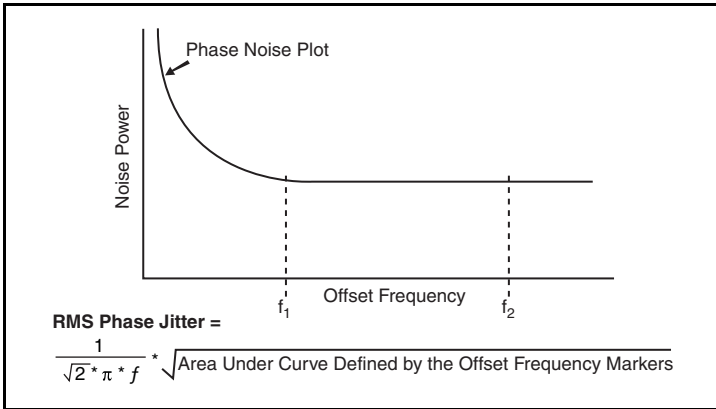

**RMS Phase Jitter**

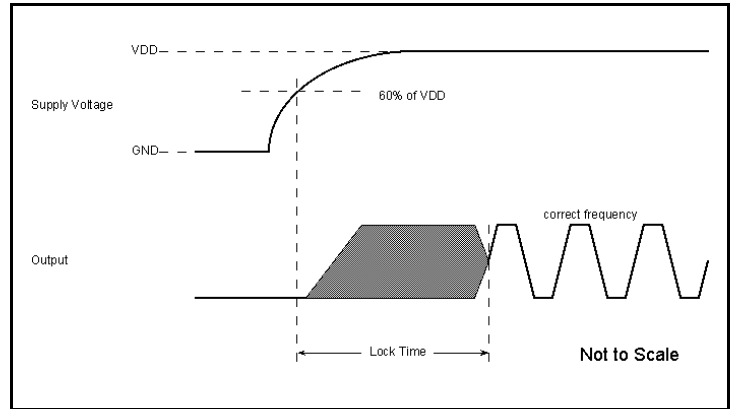

**PLL Lock Time**

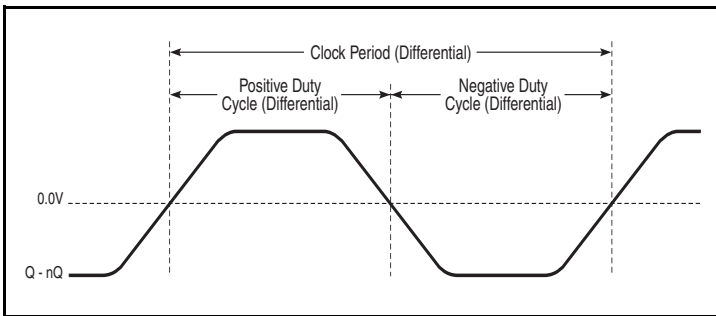

**Differential Measurement Points for Duty Cycle/Period**

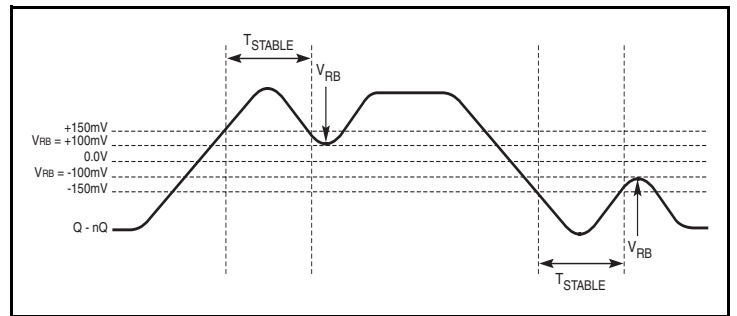

**Differential Measurement Points for Ringback**

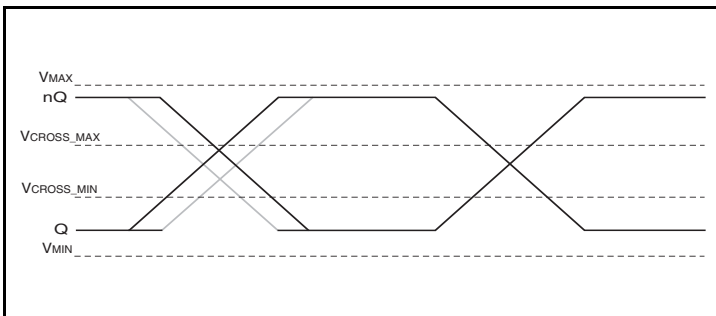

**Single-ended Measurement Points for Absolute Cross Point and Swing**

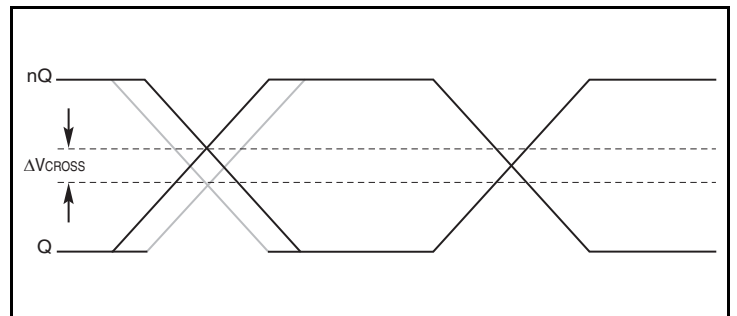

**Single-ended Measurement Points for Delta Cross Point**

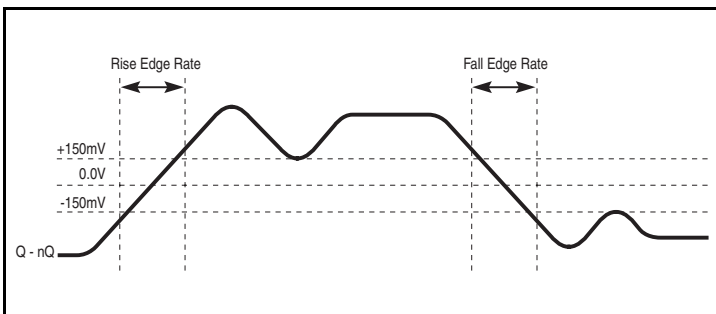

**Differential Measurement Points for Rise/Fall Edge Rate**

## Applications Information

### Recommendations for Unused Input and Output Pins

#### Inputs:

##### CLK/nCLK Inputs

For applications not requiring the use of the differential input, both CLK and nCLK can be left floating. Though not required, but for additional protection, a 1kΩ resistor can be tied from CLK to ground.

##### Crystal Inputs

For applications not requiring the use of the crystal oscillator input, both XTAL\_IN and XTAL\_OUT can be left floating. Though not required, but for additional protection, a 1kΩ resistor can be tied from XTAL\_IN to ground.

#### LVC MOS Control Pins

All control pins have internal pulldowns; additional resistance is not required but can be added for additional protection. A 1kΩ resistor can be used.

#### Outputs:

##### Differential Outputs

All unused differential outputs can be left floating. We recommend that there is no trace attached. Both sides of the differential output pair should either be left floating or terminated.

### Wiring the Differential Input to Accept Single-Ended Levels

Figure 1 shows how a differential input can be wired to accept single ended levels. The reference voltage  $V_1 = V_{DD}/2$  is generated by the bias resistors R1 and R2. The bypass capacitor (C1) is used to help filter noise on the DC bias. This bias circuit should be located as close to the input pin as possible. The ratio of R1 and R2 might need to be adjusted to position the  $V_1$  in the center of the input voltage swing. For example, if the input clock swing is 2.5V and  $V_{DD} = 3.3V$ , R1 and R2 value should be adjusted to set  $V_1$  at 1.25V. The values below are for when both the single ended swing and  $V_{DD}$  are at the same voltage. This configuration requires that the sum of the output impedance of the driver ( $R_o$ ) and the series resistance ( $R_s$ ) equals the transmission line impedance. In addition, matched termination at the input will attenuate the signal in half. This can be done in two ways. First, R3 and R4 in parallel should equal the transmission

line impedance. For most 50Ω applications, R3 and R4 can be 100Ω. The values of the resistors can be increased to reduce the loading for slower and weaker LVC MOS driver. When using single-ended signaling, the noise rejection benefits of differential signaling are reduced. Even though the differential input can handle full rail LVC MOS signaling, it is recommended that the amplitude be reduced. The datasheet specifies a lower differential amplitude, however this only applies to differential signals. For single-ended applications, the swing can be larger, however  $V_{IL}$  cannot be less than -0.3V and  $V_{IH}$  cannot be more than  $V_{DD} + 0.3V$ . Though some of the recommended components might not be used, the pads should be placed in the layout. They can be utilized for debugging purposes. The datasheet specifications are characterized and guaranteed by using a differential signal.

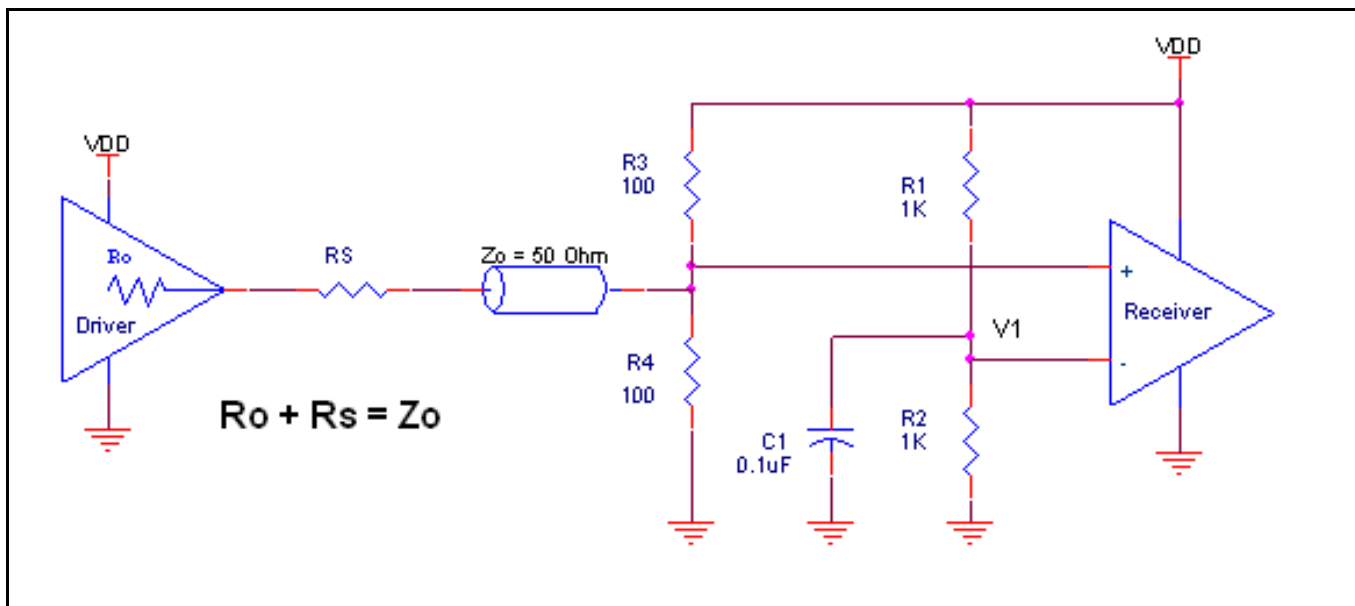
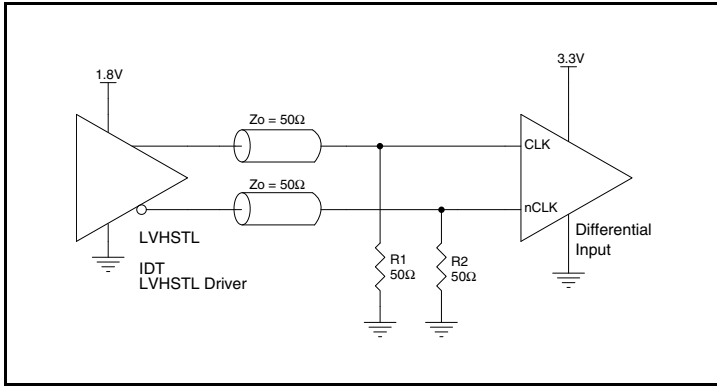

Figure 1. Recommended Schematic for Wiring a Differential Input to Accept Single-ended Levels

## Differential Clock Input Interface

The CLK /nCLK accepts LVDS, LVPECL, LVHSTL, HCSL and other differential signals. Both signals must meet the  $V_{PP}$  and  $V_{CMR}$  input requirements. *Figures 2A to 2E* show interface examples for the CLK/nCLK input driven by the most common driver types. The input interfaces suggested here are examples only. Please consult with the

vendor of the driver component to confirm the driver termination requirements. For example, in Figure 2A, the input termination applies for IDT open emitter LVHSTL drivers. If you are using an LVHSTL driver from another vendor, use their termination recommendation.



**Figure 2A. CLK/nCLK Input Driven by an IDT Open Emitter LVHSTL Driver**

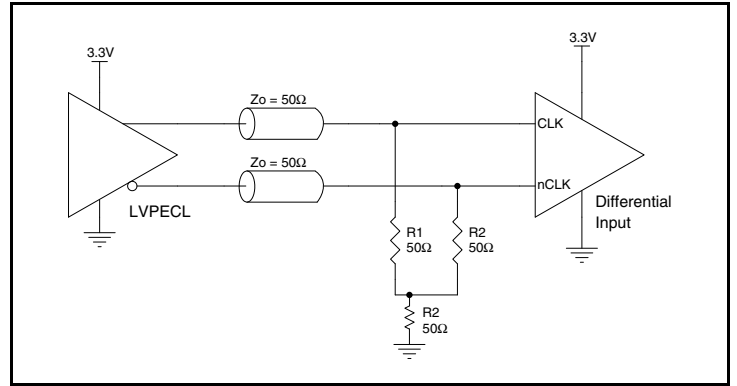

**Figure 2B. CLK/nCLK Input Driven by a 3.3V LVPECL Driver**

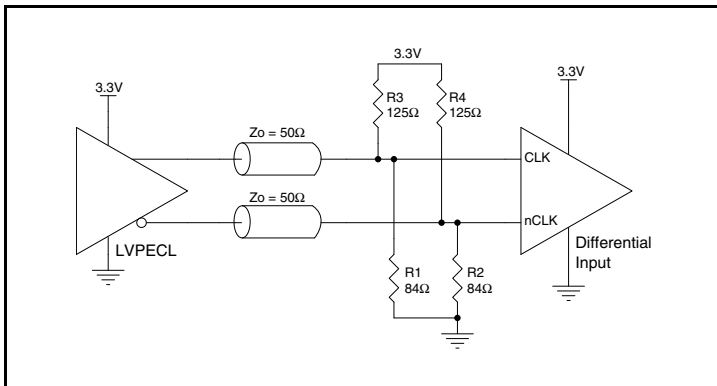

**Figure 2C. CLK/nCLK Input Driven by a 3.3V LVPECL Driver**

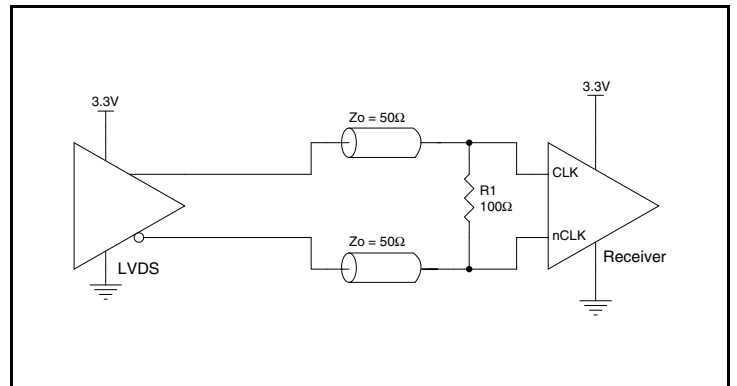

**Figure 2D. CLK/nCLK Input Driven by a 3.3V LVDS Driver**

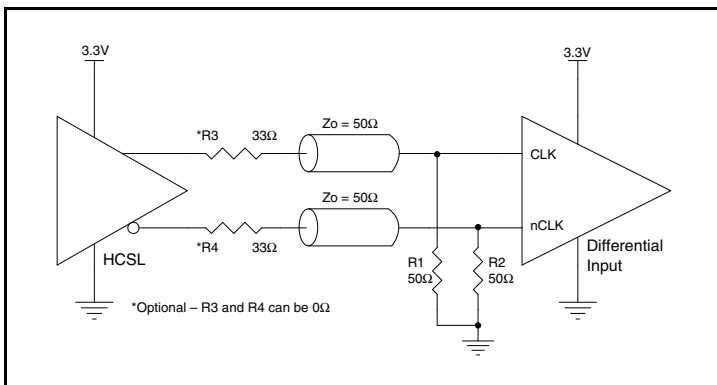

**Figure 2E. CLK/nCLK Input Driven by a 3.3V HCSL Driver**

## Power Supply Sequence Requirement

The IDT8V41N004I has a power supply sequence requirement. This device requires that  $V_{DD}$  and  $V_{DDA}$  are powered simultaneously. This device has been characterized using the recommended power supply filtering techniques in *Figure 4*.

## Overdriving the XTAL Interface

The XTAL\_IN input can be overdriven by an LVCMOS driver or by one side of a differential driver through an AC coupling capacitor. The XTAL\_OUT pin can be left floating. The amplitude of the input signal should be between 500mV and 1.8V and the slew rate should not be less than 0.2V/nS. For 3.3V LVCMOS inputs, the amplitude must be reduced from full swing to at least half the swing in order to prevent signal interference with the power rail and to reduce internal noise. *Figure 3A* shows an example of the interface diagram for a high speed 3.3V LVCMOS driver. This configuration requires that the sum of the output impedance of the driver ( $R_o$ ) and the series resistance ( $R_s$ ) equals the transmission line impedance. In addition, matched termination at the crystal input will attenuate the signal in half. This

can be done in one of two ways. First,  $R_1$  and  $R_2$  in parallel should equal the transmission line impedance. For most 50Ω applications,  $R_1$  and  $R_2$  can be 100Ω. This can also be accomplished by removing  $R_1$  and changing  $R_2$  to 50Ω. The values of the resistors can be increased to reduce the loading for a slower and weaker LVCMOS driver. *Figure 3B* shows an example of the interface diagram for an LVPECL driver. This is a standard LVPECL termination with one side of the driver feeding the XTAL\_IN input. It is recommended that all components in the schematics be placed in the layout. Though some components might not be used, they can be utilized for debugging purposes. The datasheet specifications are characterized and guaranteed by using a quartz crystal as the input.

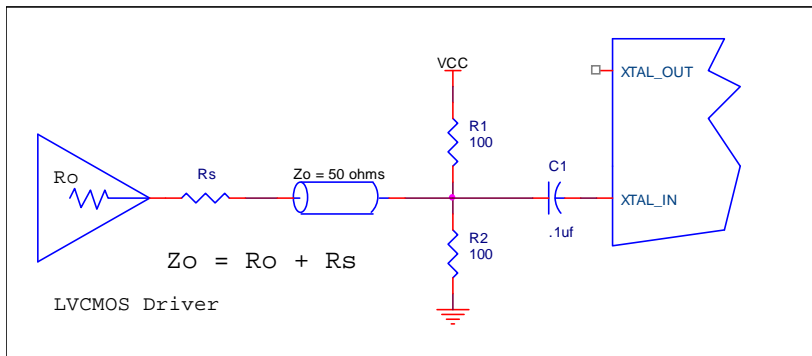

Figure 3A. General Diagram for LVCMOS Driver to XTAL Input Interface

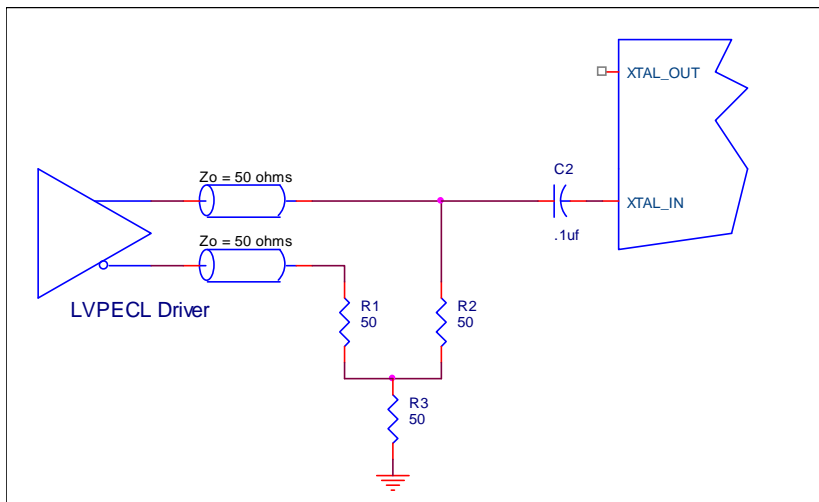

Figure 3B. General Diagram for LVPECL Driver to XTAL Input Interface

## Schematic Example

Figure 4 (next page) shows an example of an IDT8V41N004I application schematic. The schematic example focuses on functional connections and is intended as an example only. It may not represent the exact user configuration. Refer to the pin description and functional tables in the datasheet to ensure that the logic control inputs are properly set. For example, OE[3:0] and FSEL[1:0] can be configured from an FPGA instead of set with pull up and pull down resistors as shown.

For this device, the crystal load capacitors are required for proper operation. A 12pF parallel resonant 25MHz crystal is used. The load capacitance  $C1 = C2 = 1\text{pF}$  is recommended for frequency accuracy. Depending on the parasitic of the printed circuit board layout, these values might require a slight adjustment to optimize the frequency accuracy. Crystals with other load capacitance specifications can be used, but this will require adjusting C1 and C2.

The schematic example shows two different HCSL output terminations; the standard termination when the HCSL receiver is on the same PCB as the IDT8V41N004I as well as the termination for a PCIe add-in card.

As with any high speed analog circuitry, the power supply pins are vulnerable to noise. To achieve optimum jitter performance, power

supply isolation is required. The IDT8V41N004I provides separate power supply pins to isolate noise from coupling into the internal PLL. In order to achieve the best possible filtering, it is highly recommended that the 0.1uF capacitors at the output of the LC filter be placed on the IDT8V41N004I side of the PCB as close to the corresponding power pin as possible. This is represented by the placement of these capacitors in the schematic.

Do not share ground vias; use at least one ground via per 0.1uF cap or crystal load cap. If space is limited, the ferrite beads, 10uF capacitors and the 0.1uF capacitors connected directly to 3.3V can be placed on the opposite side of the PCB. If space permits, place all filter components on the device side of the board.

Power supply filter recommendations are a general guideline to be used for reducing external noise from coupling into the devices. The filter performance is designed for a wide range of noise frequencies. This low-pass filter starts to attenuate noise at approximately 10kHz. If a specific frequency noise component is known, such as switching power supplies frequencies, it is recommended that component values be adjusted and if required, additional filtering be added. Additionally, good general design practices for power plane voltage stability suggests adding bulk capacitance in the local area of all devices.

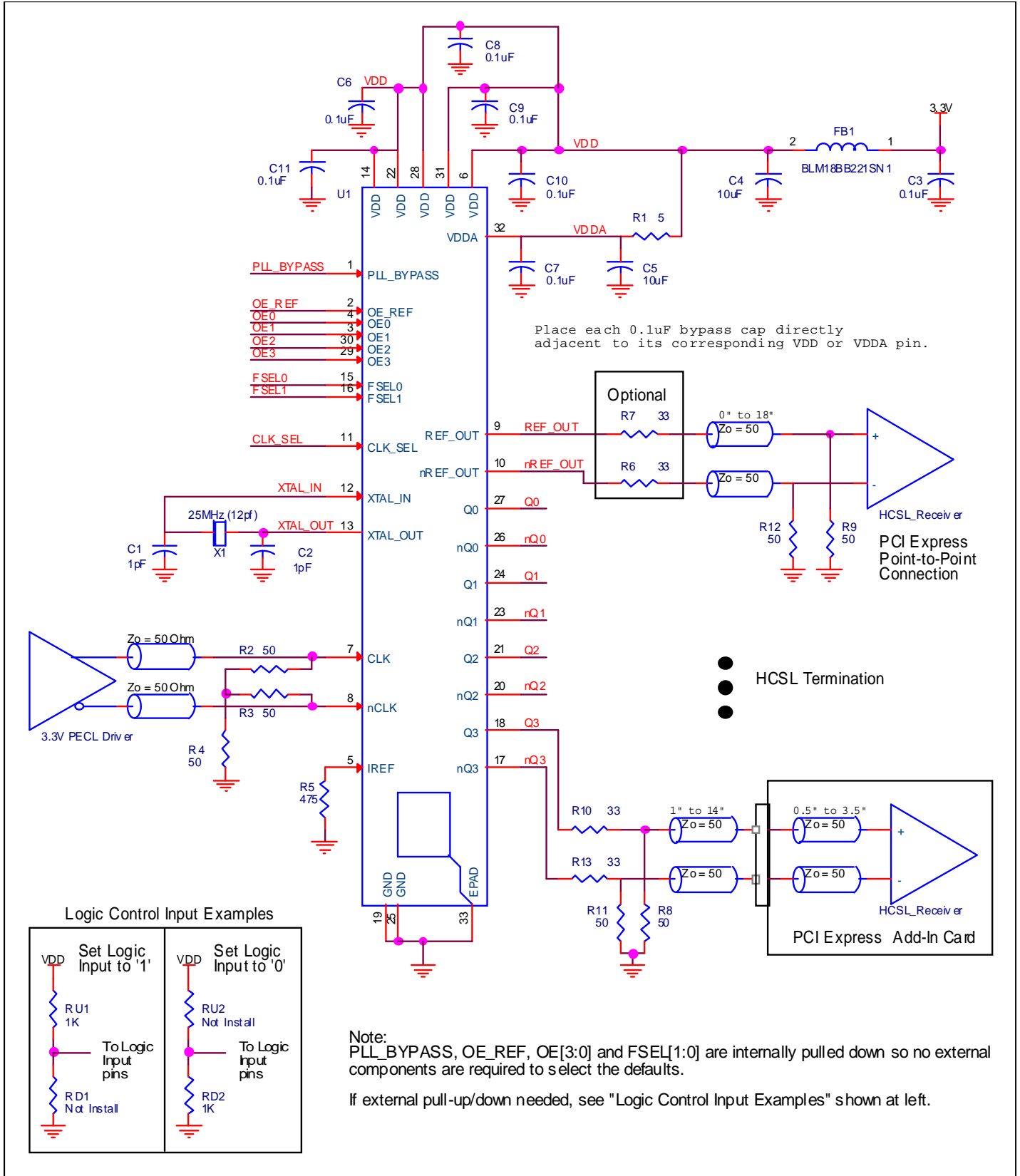

Figure 4. IDT8V41N004I Schematic Layout

## PCI Express Application Note

PCI Express jitter analysis methodology models the system response to reference clock jitter. The block diagram below shows the most frequently used *Common Clock Architecture* in which a copy of the reference clock is provided to both ends of the PCI Express Link.

In the jitter analysis, the transmit (Tx) and receive (Rx) serdes PLLs are modeled as well as the phase interpolator in the receiver. These transfer functions are called H1, H2, and H3 respectively. The overall system transfer function at the receiver is:

$$H_t(s) = H_3(s) \times [H_1(s) - H_2(s)]$$

The jitter spectrum seen by the receiver is the result of applying this system transfer function to the clock spectrum X(s) and is:

$$Y(s) = X(s) \times H_3(s) \times [H_1(s) - H_2(s)]$$

In order to generate time domain jitter numbers, an inverse Fourier Transform is performed on X(s)\*H3(s) \* [H1(s) - H2(s)].

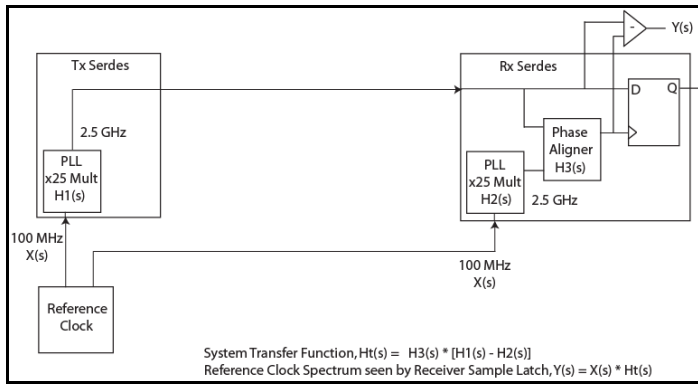

### PCI Express Common Clock Architecture

For **PCI Express Gen 1**, one transfer function is defined and the evaluation is performed over the entire spectrum: DC to Nyquist (e.g. for a 100MHz reference clock: 0Hz – 50MHz) and the jitter result is reported in peak-peak.

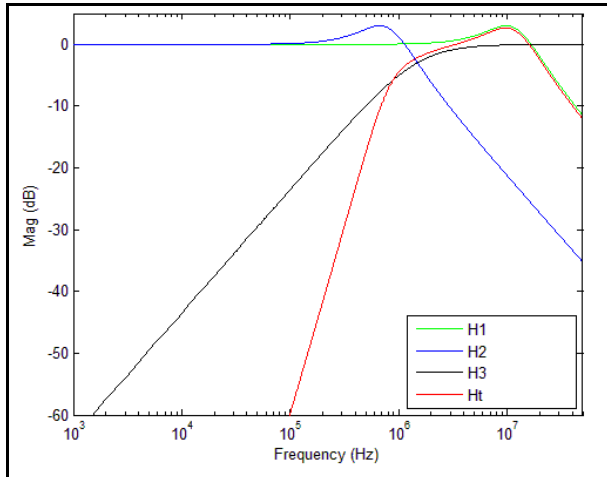

PCI Express Gen 1 Magnitude of Transfer Function

For **PCI Express Gen 2**, two transfer functions are defined with 2 evaluation ranges and the final jitter number is reported in rms. The two evaluation ranges for PCI Express Gen 2 are 10kHz – 1.5MHz (Low Band) and 1.5MHz – Nyquist (High Band). The plots show the individual transfer functions as well as the overall transfer function Ht.

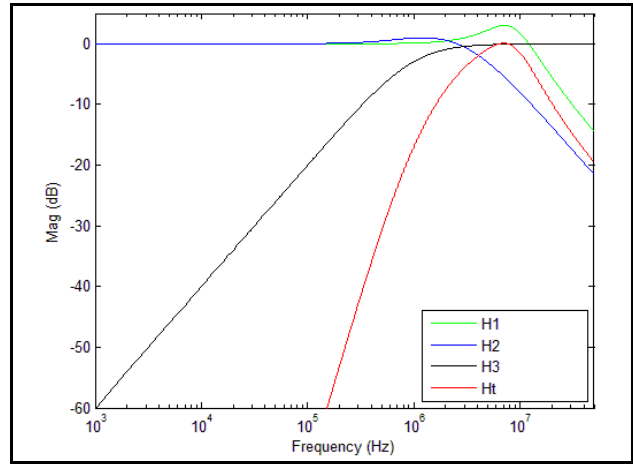

PCI Express Gen 2A Magnitude of Transfer Function

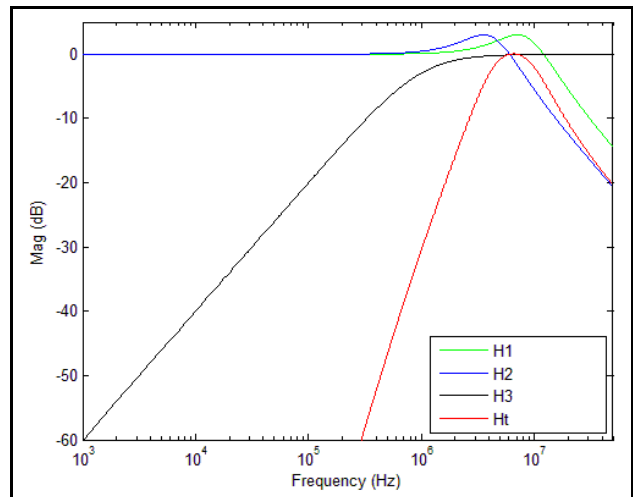

PCI Express Gen 2B Magnitude of Transfer Function

For **PCI Express Gen 3**, one transfer function is defined and the evaluation is performed over the entire spectrum. The transfer function parameters are different from Gen 1 and the jitter result is reported in RMS.

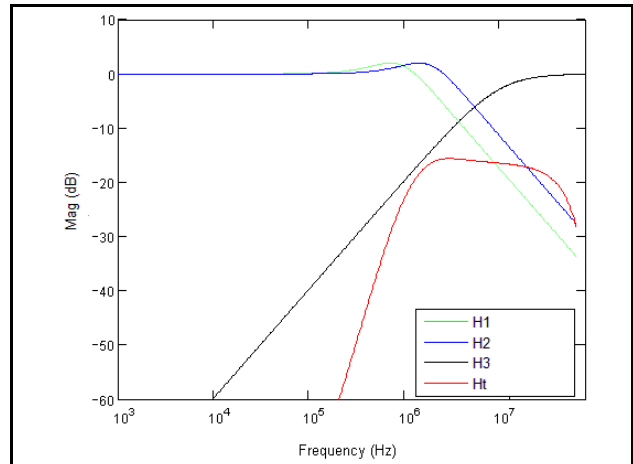

PCI Express Gen 3 Magnitude of Transfer Function

For a more thorough overview of PCI Express jitter analysis methodology, please refer to IDT Application Note *PCI Express Reference Clock Requirements*.

## VFQFN EPAD Thermal Release Path

In order to maximize both the removal of heat from the package and the electrical performance, a land pattern must be incorporated on the Printed Circuit Board (PCB) within the footprint of the package corresponding to the exposed metal pad or exposed heat slug on the package, as shown in *Figure 5*. The solderable area on the PCB, as defined by the solder mask, should be at least the same size/shape as the exposed pad/slug area on the package to maximize the thermal/electrical performance. Sufficient clearance should be designed on the PCB between the outer edges of the land pattern and the inner edges of pad pattern for the leads to avoid any shorts.

While the land pattern on the PCB provides a means of heat transfer and electrical grounding from the package to the board through a solder joint, thermal vias are necessary to effectively conduct from the surface of the PCB to the ground plane(s). The land pattern must be connected to ground through these vias. The vias act as “heat pipes”. The number of vias (i.e. “heat pipes”) are application specific

and dependent upon the package power dissipation as well as electrical conductivity requirements. Thus, thermal and electrical analysis and/or testing are recommended to determine the minimum number needed. Maximum thermal and electrical performance is achieved when an array of vias is incorporated in the land pattern. It is recommended to use as many vias connected to ground as possible. It is also recommended that the via diameter should be 12 to 13mils (0.30 to 0.33mm) with 1oz copper via barrel plating. This is desirable to avoid any solder wicking inside the via during the soldering process which may result in voids in solder between the exposed pad/slug and the thermal land. Precautions should be taken to eliminate any solder voids between the exposed heat slug and the land pattern. Note: These recommendations are to be used as a guideline only. For further information, please refer to the Application Note on the Surface Mount Assembly of Amkor’s Thermally/Electrically Enhance Leadframe Base Package, Amkor Technology.

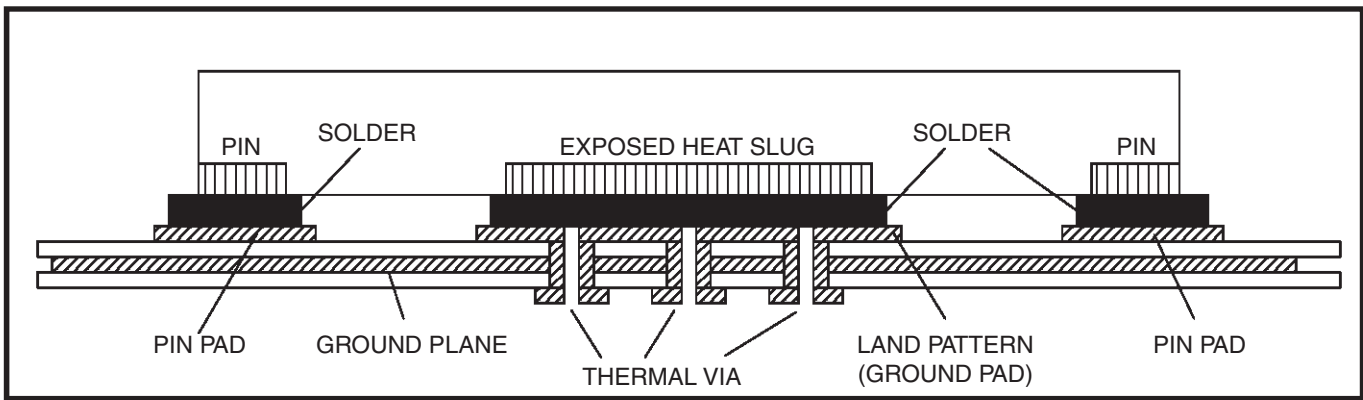
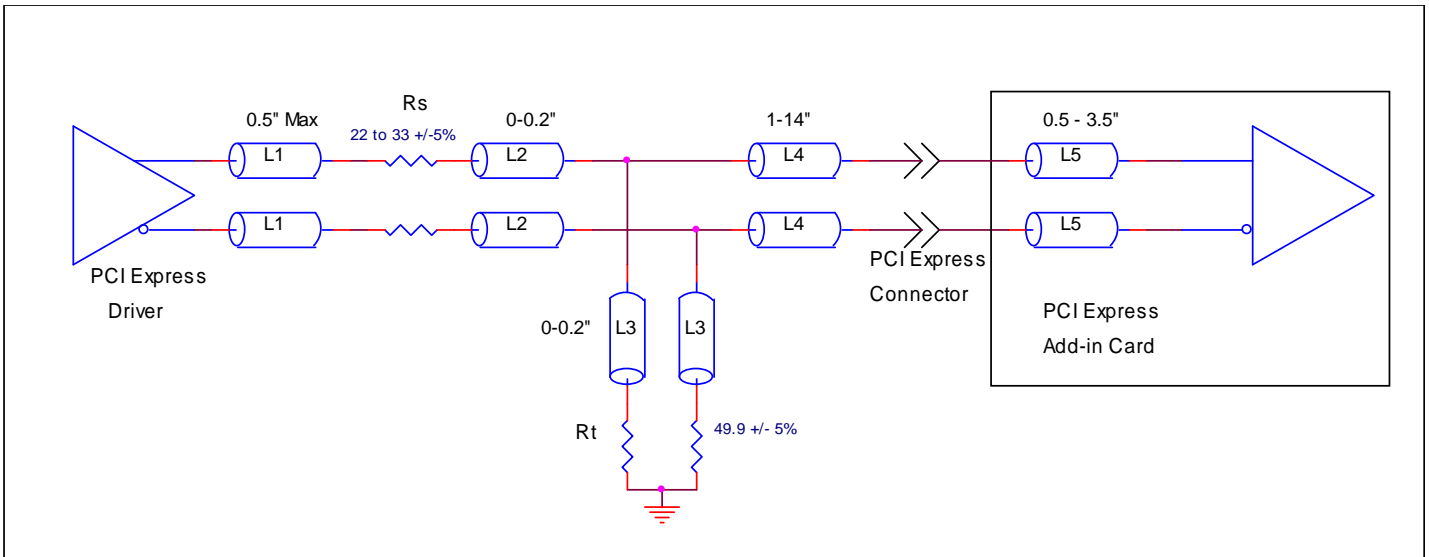

**Figure 5. P.C. Assembly for Exposed Pad Thermal Release Path – Side View (drawing not to scale)**

## Recommended Termination

Figure 6A is the recommended source termination for applications where the driver and receiver will be on a separate PCBs. This termination is the standard for PCI Express™ and HCSL output

types. All traces should be 50Ω impedance single-ended or 100Ω differential.



**Figure 6A. Recommended Source Termination (where the driver and receiver will be on separate PCBs)**

Figure 6B is the recommended termination for applications where a point-to-point connection can be used. A point-to-point connection contains both the driver and the receiver on the same PCB. With a matched termination at the receiver, transmission-line reflections will

be minimized. In addition, a series resistor (Rs) at the driver offers flexibility and can help dampen unwanted reflections. The optional resistor can range from 0Ω to 33Ω. All traces should be 50Ω impedance single-ended or 100Ω differential.

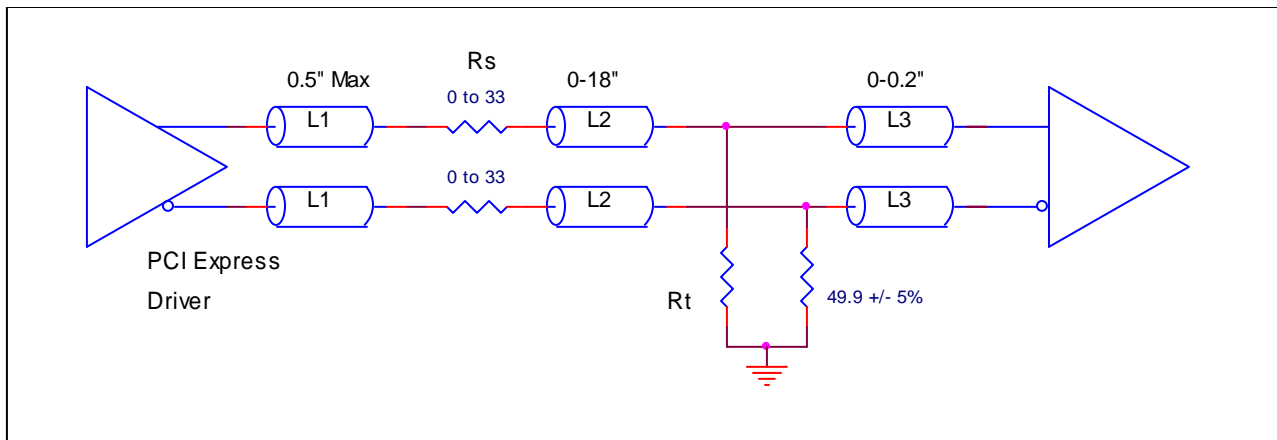

**Figure 6B. Recommended Termination (where a point-to-point connection can be used)**

## Power Considerations

This section provides information on power dissipation and junction temperature for the IDT8V41N004I. Equations and example calculations are also provided.

### 1. Power Dissipation.

The total power dissipation for the IDT8V41N004I is the sum of the core power plus analog power plus the power dissipation at the outputs. The following is the power dissipation for  $V_{DD} = 3.3V + 5\% = 3.465V$ , which gives worst case results.

NOTE: Please refer to Section 3 for details on calculating power dissipation at the outputs.

- Power (core)<sub>MAX</sub> =  $V_{DD\_MAX} * (I_{DD\_MAX} + I_{DDA\_MAX}) = 3.465V * (121mA + 31mA) = \mathbf{526.7mW}$
- Power (outputs)<sub>MAX</sub> = **44.5mW/Loaded Output pair**  
If all outputs are loaded, the total power is  $5 * 44.5mW = \mathbf{222.5mW}$

**Total Power<sub>MAX</sub>** = (3.465V, if all outputs are loaded) =  $526.7mW + 222.5mW = \mathbf{749.2mW}$

### 2. Junction Temperature.

Junction temperature,  $T_j$ , is the temperature at the junction of the bond wire and bond pad directly affects the reliability of the device. The maximum recommended junction temperature is 125°C. Limiting the internal transistor junction temperature,  $T_j$ , to 125°C ensures that the bond wire and bond pad temperature remains below 125°C.

The equation for  $T_j$  is as follows:  $T_j = \theta_{JA} * Pd\_total + T_A$

$T_j$  = Junction Temperature

$\theta_{JA}$  = Junction-to-Ambient Thermal Resistance

$Pd\_total$  = Total Device Power Dissipation (example calculation is in section 1 above)

$T_A$  = Ambient Temperature

In order to calculate junction temperature, the appropriate junction-to-ambient thermal resistance  $\theta_{JA}$  must be used. Assuming no air flow and a multi-layer board, the appropriate value is 33.1°C/W per Table 7 below.

Therefore,  $T_j$  for an ambient temperature of 85°C with all outputs switching is:

$$85^\circ\text{C} + 0.749\text{W} * 33.1^\circ\text{C/W} = 109.8^\circ\text{C}. \text{ This is below the limit of } 125^\circ\text{C}.$$

This calculation is only an example.  $T_j$  will obviously vary depending on the number of loaded outputs, supply voltage, air flow and the type of board (multi-layer).

**Table 7. Thermal Resistance  $\theta_{JA}$  for 32 Lead VFQFN, Forced Convection**

$\theta_{JA}$ vs. Air Flow			
Meters per Second	0	1	3
Multi-Layer PCB, JEDEC Standard Test Boards	33.1°C/W	28.1°C/W	25.4°C/W

### 3. Calculations and Equations.

The purpose of this section is to calculate power dissipation on the IC per HCSL output pairs.

HCSL output driver circuit and termination are shown in *Figure 7*.

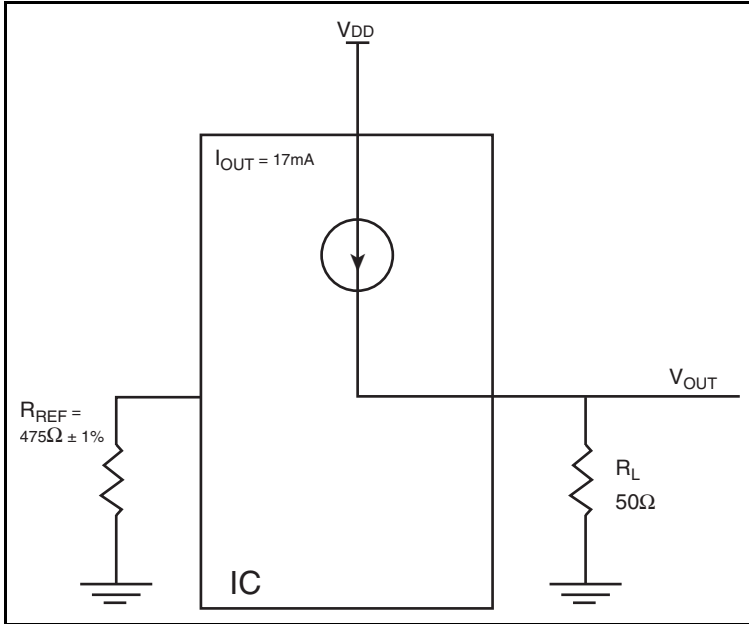

**Figure 7. HCSL Driver Circuit and Termination**

HCSL is a current steering output which sources a maximum of 17mA of current per output. To calculate worst case on-chip power dissipation, use the following equations which assume a 50Ω load to ground.

The highest power dissipation occurs at  $V_{DD\_MAX}$ .

$$\text{Power} = (V_{DD\_MAX} - V_{OUT}) * I_{OUT}$$

since  $V_{OUT} = I_{OUT} * R_L$

$$\begin{aligned} \text{Power} &= (V_{DD\_MAX} - I_{OUT} * R_L) * I_{OUT} \\ &= (3.465V - 17mA * 50\Omega) * 17mA \end{aligned}$$

Total Power Dissipation per output pair = **44.5mW**

## Reliability Information

**Table 7.  $\theta_{JA}$  vs. Air Flow Table for a 32 Lead VFQFN**

$\theta_{JA}$ vs. Air Flow			
Meters per Second	<b>0</b>	<b>1</b>	<b>3</b>
Multi-Layer PCB, JEDEC Standard Test Boards	33.1°C/W	28.1°C/W	25.4°C/W

## Transistor Count

The transistor count for IDT8V41N004I is: 24,809

### 32 Lead VFQFN Package Outline and Package Dimensions

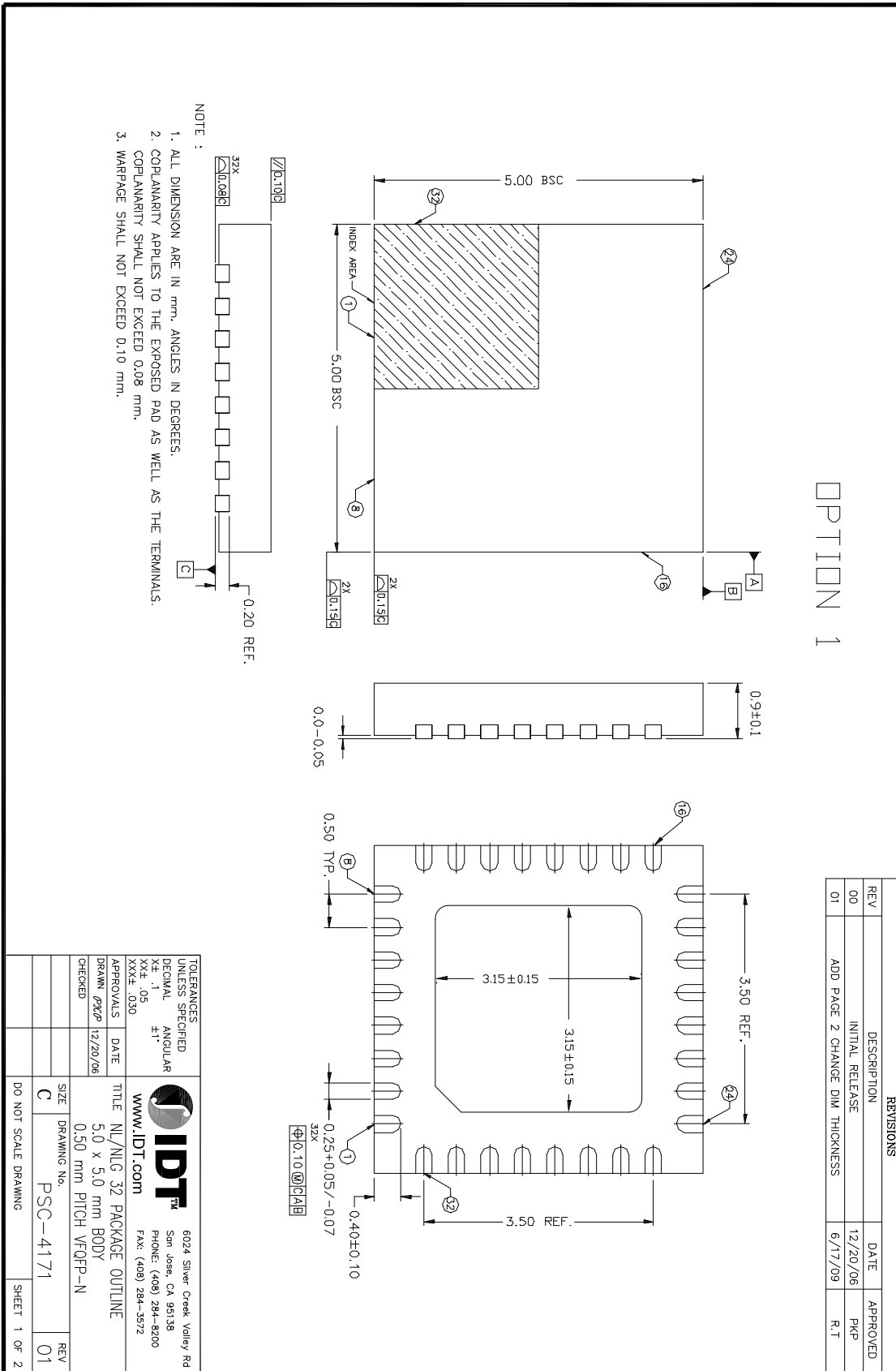

## Ordering Information

Table 8. Ordering Information

Part/Order Number	Marking	Package	Shipping Packaging	Temperature
8V41N004NLGI	IDT8V41N004NLGI	"Lead-Free" 32 Lead VFQFN	Tray	-40°C to 85°C
8V41N004NLGI8	IDT8V41N004NLGI	"Lead-Free" 32 Lead VFQFN	Tape & Reel	-40°C to 85°C



## IMPORTANT NOTICE AND DISCLAIMER

RENESAS ELECTRONICS CORPORATION AND ITS SUBSIDIARIES (“RENESAS”) PROVIDES TECHNICAL SPECIFICATIONS AND RELIABILITY DATA (INCLUDING DATASHEETS), DESIGN RESOURCES (INCLUDING REFERENCE DESIGNS), APPLICATION OR OTHER DESIGN ADVICE, WEB TOOLS, SAFETY INFORMATION, AND OTHER RESOURCES “AS IS” AND WITH ALL FAULTS, AND DISCLAIMS ALL WARRANTIES, EXPRESS OR IMPLIED, INCLUDING, WITHOUT LIMITATION, ANY IMPLIED WARRANTIES OF MERCHANTABILITY, FITNESS FOR A PARTICULAR PURPOSE, OR NON-INFRINGEMENT OF THIRD-PARTY INTELLECTUAL PROPERTY RIGHTS.

These resources are intended for developers who are designing with Renesas products. You are solely responsible for (1) selecting the appropriate products for your application, (2) designing, validating, and testing your application, and (3) ensuring your application meets applicable standards, and any other safety, security, or other requirements. These resources are subject to change without notice. Renesas grants you permission to use these resources only to develop an application that uses Renesas products. Other reproduction or use of these resources is strictly prohibited. No license is granted to any other Renesas intellectual property or to any third-party intellectual property. Renesas disclaims responsibility for, and you will fully indemnify Renesas and its representatives against, any claims, damages, costs, losses, or liabilities arising from your use of these resources. Renesas' products are provided only subject to Renesas' Terms and Conditions of Sale or other applicable terms agreed to in writing. No use of any Renesas resources expands or otherwise alters any applicable warranties or warranty disclaimers for these products.

(Disclaimer Rev.1.01 Jan 2024)

### Corporate Headquarters

TOYOSU FORESIA, 3-2-24 Toyosu,  
Koto-ku, Tokyo 135-0061, Japan  
[www.renesas.com](http://www.renesas.com)

### Trademarks

Renesas and the Renesas logo are trademarks of Renesas Electronics Corporation. All trademarks and registered trademarks are the property of their respective owners.

### Contact Information

For further information on a product, technology, the most up-to-date version of a document, or your nearest sales office, please visit [www.renesas.com/contact-us/](http://www.renesas.com/contact-us/).

## Looking for pricing, stock, or lifecycle information?

Click below to explore more details on WIN SOURCE:

-  [View 8V41N004NLGI on WIN SOURCE](#)
-  [Renesas Electronics America](#) Information

## Optimize Your Supply Chain with WIN SOURCE Solutions

-  Global Sourcing Solution
-  Obsolete Management
-  Cost Control Management
-  Shortage Management
-  Alternative Solution
-  Excess Inventory Management