



**THE DATASHEET OF
8T49N240-026NLGI**



Description

The 8T49N240 is a fractional-feedback single channel jitter attenuator with frequency translation. It is equipped with three integer and one fractional output dividers, allowing the generation of up to four different output frequencies, ranging from 8kHz to 867MHz. These frequencies are completely independent of the input reference frequencies and the crystal reference frequency. The outputs may select among LVPECL, LVDS, HCSL, or LVCMOS output levels.

The 8T49N240 accepts up to two differential or single-ended input clocks and a fundamental-mode crystal input. The internal PLL can lock to either of the input reference clocks or just to the crystal to behave as a frequency synthesizer. The PLL can use the second input for redundant backup of the primary input reference, but in this case, both input clock references must be integer related in frequency.

The device supports hitless reference switching between input clocks. The device monitors both input clocks for Loss of Signal (LOS), and generates an alarm when an input clock failure is detected. Automatic and manual hitless reference switching options are supported. LOS behavior can be set to support gapped or un-gapped clocks.

The 8T49N240 supports holdover. The holdover has an initial accuracy of ± 50 ppB from the point where the loss of all applicable input reference(s) has been detected. It maintains a historical average operating point for the PLL that may be returned to in holdover at a limited phase slope.

The PLL has a register-selectable loop bandwidth from 0.2Hz to 6.4kHz.

The device supports Output Enable and Clock Select inputs and Lock, Holdover, and LOS status outputs.

The device is programmable through an I²C interface. It also supports I²C master capability to allow the register configuration to be read from an external EEPROM.

Factory pre-programmed devices are also available using the on-chip One Time Programmable (OTP) memory.

Typical Applications

- OTN, including ITU-T G.709 (2009) FEC
- CPRI interfaces
- Fiber optics
- 40G/100G Ethernet
- Gb Ethernet, Terabit IP switches / routers

Features

- Four differential outputs
- Excellent jitter performance:
 - < 200fs (typical) RMS (including spurs):
12kHz to 20MHz for integer-divider outputs in jitter attenuator mode or in fractional-feedback synthesizer mode
- Operating Modes: Synthesizer, Jitter Attenuator
- Operates from a 10MHz to 54MHz fundamental-mode crystal
- Initial holdover accuracy of ± 50 ppb
- Accepts up to two LVPECL, LVDS, LVHSTL, or LVCMOS input clocks
 - Accepts frequencies ranging from 8kHz to 875MHz
 - Auto and manual clock selection with hitless switching
 - Clock input monitoring including support for gapped clocks
- Phase-slope limiting and fully hitless switching options to control output clock phase transients
- Three outputs generate LVPECL / LVDS / HCSL clocks, one output generates LVPECL / LVDS / HCSL / LVCMOS clocks
 - Output frequencies ranging from 8kHz up to 867MHz (differential)
 - Output frequencies ranging from 8kHz to 250MHz (LVCMOS)
 - Three integer dividers with fixed divider ratios (see [Table 3](#))
 - One fractional output divider
- Programmable loop bandwidth settings from 0.2Hz to 6.4kHz
 - Optional fast-lock function
- Four General Purpose I/O pins with optional support for status and control:
 - Two Output Enable control inputs provide control over the four clocks
 - Manual clock selection control input
 - Lock, Holdover, and Loss-of-Signal alarm outputs
- Open-drain Interrupt pin
- Register programmable through I²C or via external I²C EEPROM
- Full 2.5V or 3.3V supply modes, with some support for 1.8V
- -40°C to 85°C ambient operating temperature
- Package: 6 x 6 x 0.9 mm 40-VFQFN, lead-free (RoHS 6)

Contents

Description	1
Typical Applications	1
Features	1
Block Diagram	4
Pin Assignments	5
Pin Descriptions	5
Principles of Operation	8
Crystal Input	8
Bypass Path	8
Input Clock Selection	9
Input Clock Monitor	9
Holdover	10
Input to Output Clock Frequency	10
Synthesizer Mode Operation	10
Loop Filter and Bandwidth	11
Integer Output Dividers (Q0, Q1 or Q2)	11
Fractional Output Divider Programming (Q3 Only)	11
Output Divider Frequency Sources	11
Output Phase Control on Switchover	12
Output Drivers	12
LVCMOS Operation (Q3 Only)	12
Power-Saving Modes	12
Status / Control Signals and Interrupts	12
General-Purpose I/Os and Interrupts	13
Interrupt Functionality	13
Output Enable Operation	13
Device Hardware Configuration	14
Device Start-up and Reset Behavior	14
Serial Control Port Description	15
Serial Control Port Configuration Description	15
I2C Mode Operation	15
I2C Master Mode	16
I2C Boot-up Initialization Mode	17
Absolute Maximum Ratings	40
Supply Voltage Characteristics	40
DC Electrical Characteristics	42
AC Electrical Characteristics	45
Typical Phase Noise at 156.25MHz	52
Applications Information	53
Recommendations for Unused Input and Output Pins	53
Inputs	53
Outputs	53
Overdriving the XTAL Interface	54
Wiring the Differential Input to Accept Single-Ended Levels	55
3.3V Differential Clock Input Interface	56
2.5V Differential Clock Input Interface	57
LVDS Driver Termination	58
Termination for 3.3V LVPECL Outputs	59

Termination for 2.5V LVPECL Outputs	60
HCSL Recommended Termination	61
VFQFN EPAD Thermal Release Path	62
Schematic and Layout Information	62
Crystal Recommendation	62
PCI Express Application Note	63
Power Dissipation and Thermal Considerations	64
Power Domains	64
Power Consumption Calculation	64
Thermal Considerations	65
Current Consumption Data and Equations	65
Example Calculations	68
Reliability Information	71
Transistor Count	71
Package Outlines Drawings	71
Marking Diagram	71
Ordering Information	71
Revision History	73

Block Diagram

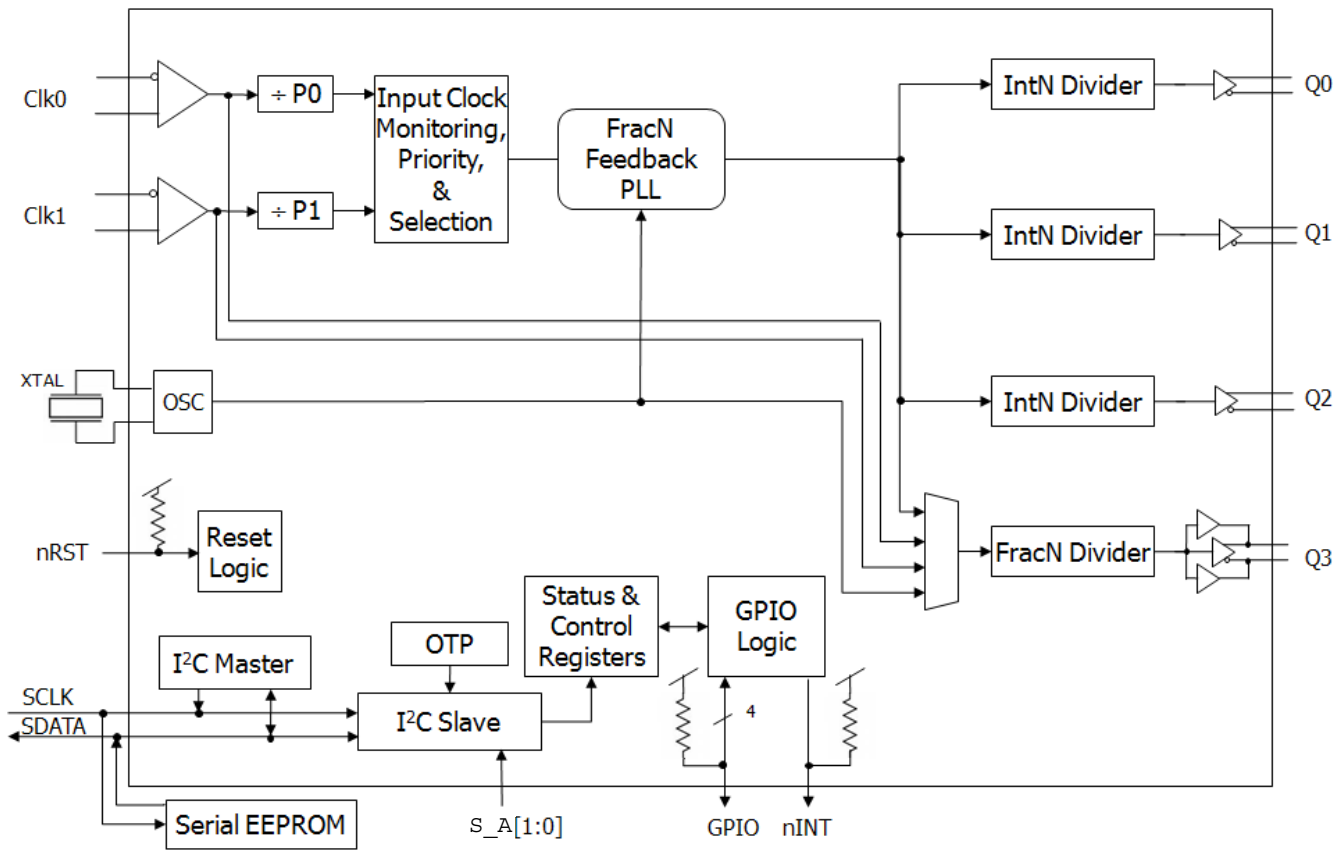

Pin Assignments

Figure 1. Pin Assignments for 6mm x 6mm 40-Lead VFQFN Package

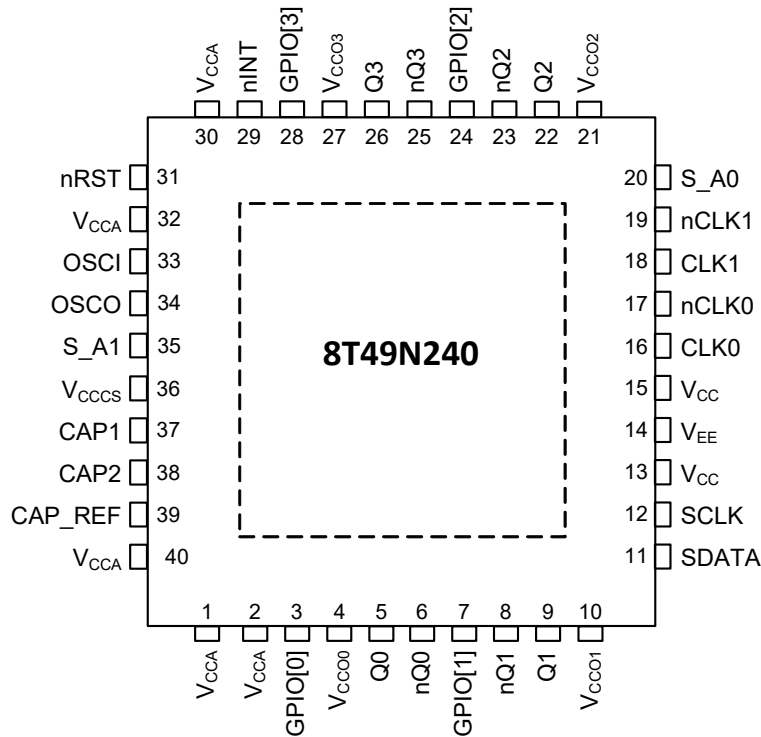

Pin Descriptions

Table 1. Pin Descriptions ^[a]

Number	Name	Type		Description
1	V _{CCA}	Power		Analog function supply for core analog functions. 2.5V or 3.3V supported.
2	V _{CCA}	Power		Analog function supply for analog functions associated with PLL. 2.5V or 3.3V supported.
3	GPIO[0]	I/O	Pullup	General-purpose input-output. LVTTTL / LVCMOS Input levels.
4	V _{CC00}	Power		High-speed output supply for output pair Q0, nQ0. 2.5V or 3.3V supported for differential output types. LVCMOS outputs also support 1.8V.
5	Q0	O	Universal	Output Clock 0. For more information, see Output Drivers .
6	nQ0	O	Universal	Output Clock 0. For more information, see Output Drivers .
7	GPIO[1]	I/O	Pullup	General-purpose input-output. LVTTTL / LVCMOS Input levels.
8	nQ1	O	Universal	Output Clock 1. For more information, see Output Drivers .
9	Q1	O	Universal	Output Clock 1. For more information, see Output Drivers .
10	V _{CC01}	Power		High-speed output supply for output pair Q1, nQ1. 2.5V or 3.3V supported for differential output types. LVCMOS outputs also support 1.8V.
11	SDATA	I/O	Pullup	I ² C interface bi-directional data.
12	SCLK	I/O	Pullup	I ² C interface bi-directional clock.

Table 1. Pin Descriptions ^[a] (Cont.)

Number	Name	Type		Description
13	V _{CC}	Power		Core digital function supply. 2.5V or 3.3V supported.
14 EPAD	V _{EE}	Power		Negative supply voltage. All V _{EE} pins and EPAD must be connected before any positive supply voltage is applied.
15	V _{CC}	Power		Core digital function supply. 2.5V or 3.3V supported.
16	CLK0	I	Pulldown	Non-inverting differential clock input 0.
17	nCLK0	I	Pullup / Pulldown	Inverting differential clock input 0. V _{CC} / 2 when left floating (set by internal pullup / pulldown resistors)
18	CLK1	I	Pulldown	Non-inverting differential clock input 1.
19	nCLK1	I	Pullup / Pulldown	Inverting differential clock input 1. V _{CC} / 2 when left floating (set by internal pullup / pulldown resistors)
20	S_A0	I	Pulldown	I ² C Address Bit A0.
21	V _{CCO2}	Power		High-speed output supply voltage for output pair Q2, nQ2. 2.5V or 3.3V supported for differential output types. LVCMOS outputs also support 1.8V.
22	Q2	O	Universal	Output Clock 2. For more information, see Output Drivers .
23	nQ2	O	Universal	Output Clock 2. For more information, see Output Drivers .
24	GPIO[2]	I/O	Pullup	General-purpose input-output. LVTTL / LVCMOS Input levels.
25	nQ3	O	Universal	Output Clock 3. For more information, see Output Drivers .
26	Q3	O	Universal	Output Clock 3. For more information, see Output Drivers .
27	V _{CCO3}	Power		High-speed output supply voltage for output pair Q3, nQ3. 2.5V or 3.3V supported for differential output types. LVCMOS outputs also support 1.8V.
28	GPIO[3]	I/O	Pullup	General-purpose input-output. LVTTL / LVCMOS Input levels.
29	nINT	O	Open-drain with pullup	Interrupt output.
30	V _{CCA}	Power		Analog function supply for analog functions associated with PLL. 2.5V or 3.3V supported.
31	nRST	I	Pullup	Master Reset input> LVTTL / LVCMOS interface levels: 0 = All registers and state machines are reset to their default values 1 = Device runs normally
32	V _{CCA}	Power		Analog function supply for core analog functions. 2.5V or 3.3V supported.
33	OSCI	I		Crystal Input. Accepts a 10MHz - 54MHz reference from a clock oscillator or a 12pF fundamental mode, parallel-resonant crystal.
34	OSCO	O		Crystal Output. This pin should be connected to a crystal. If an oscillator is connected to OSCI, then this pin must be left unconnected.
35	S_A1	I	Pulldown	I ² C Address bit A1.
36	V _{CCCS}	Power		Output supply for Control and Status pins: GPIO[3:0], SDATA, SCLK, S_A0, nINT, nRST, S_A1 1.8V, 2.5V, or 3.3V supported.
37	CAP1	Analog		PLL External Capacitance.

Table 1. Pin Descriptions ^[a] (Cont.)

Number	Name	Type	Description
38	CAP2	Analog	PLL External Capacitance.
39	CAP_REF	Analog	External Capacitance for input reference clock circuitry.
40	V _{CCA}	Power	Analog function supply for analog functions associated with PLL. 2.5V or 3.3V supported.

[a] *Pullup* and *Pulldown* refer to internal input resistors. See Table 2, *Pin Characteristics*, for typical values.

 Table 2. Pin Characteristics, V_{CC} = V_{CCOX} ^[a] = 3.3V±5% or 2.5V±5%

Symbol	Parameter	Test Conditions	Minimum	Typical	Maximum	Units
C _{IN}	Input Capacitance ^[b]			3.5		pF
C _{XTAL}	Crystal Pins (OSCI, OSCO) Internal Capacitance			8		pF
R _{PULLUP}	Input Pullup Resistor	SDATA, SCLK, nRST, GPIO[3:0]		51		kΩ
R _{PULLDOWN}	Input Pulldown Resistor	S_A0, S_A1		51		kΩ
C _{PD}	Power Dissipation Capacitance (per output pair)	Q3, LVCMOS	V _{CCOX} = 3.465V	13		pF
			V _{CCOX} = 2.625V	15		pF
			V _{CCOX} = 1.89V	15		pF
		LVDS, HCSSL or LVPECL Q[0:2]		2.5		pF
		Q3, LVDS, HCSSL or LVPECL		4.5		pF
R _{OUT}	Output Impedance	GPIO[3:0]	V _{CCCS} = 3.3V	26		Ω
			V _{CCCS} = 2.5V	32		
			V _{CCCS} = 1.8V	39		
		LVCMOS Q3, nQ3	V _{CCOX} = 3.3V	18		Ω
			V _{CCOX} = 2.5V	18		
			V _{CCOX} = 1.8V	24		

[a] V_{CCOX} denotes: V_{CC00}, V_{CC01}, V_{CC02} or V_{CC03}.

[b] This specification does not apply to the OSCI or OSCO pins.

Principles of Operation

The 8T49N240 can be locked to either of the input clocks and generate a wide range of synchronized output clocks. It could be used for example in either the transmit or receive path of Synchronous Ethernet equipment.

The 8T49N240 accepts up to two differential or single-ended input clocks ranging from 8kHz up to 875MHz. It generates up to four output clocks ranging from 8kHz up to 867MHz.

The PLL path within the 8T49N240 supports three states: Lock, Holdover and Free-run. Lock and holdover status may be monitored on register bits and pins. The PLL also supports automatic and manual hitless reference switching. In the locked state, the PLL locks to a valid clock input and its output clocks have a frequency accuracy equal to the frequency accuracy of the input clock. In the Holdover state, the PLL will output a clock which is based on the selected holdover behavior. The PLL within the 8T49N240 has an initial holdover frequency offset of ± 50 ppb. In the Free-run state, the PLL outputs a clock with the same frequency accuracy as the external crystal.

Upon power up, the PLL will enter Free-run state, in this state it generates output clocks with the same frequency accuracy as the external crystal. The 8T49N240 continuously monitors each input for activity (signal transitions). If no input references are provided, the device will remain locked to the crystal in Free-run state and will generate output frequencies as a synthesizer.

When an input clock has been validated the PLL will transition to the Lock state. In automatic reference switching, if the selected input clock fails and there are no other valid input clocks, the PLL will quickly detect that and go into Holdover. In the Holdover state, the PLL will output a clock which is based on the selected holdover behavior. If the selected input clock fails and another input clock is available then the 8T49N240 will hitlessly switch to that input clock. The reference switch can be either revertive or non-revertive. Manual switchover is also available with switchover only occurring on user command, either via register bit or via the Clock Select input function of the GPIO[3:0] pins.

The device supports conversion of any input frequencies to four different output frequencies: one independent output frequency on Q3 and three more integer-related frequencies on Q[0:2].

The 8T49N240 has a programmable loop bandwidth from 0.2Hz to 6.4kHz.

The device monitors all input clocks and generates an alarm when an input clock failure is detected.

The device is programmable through an I²C and may also autonomously read its register settings from an internal One-Time Programmable (OTP) memory or an external serial I²C EEPROM.

Crystal Input

The crystal input on the 8T49N240 is capable of being driven by a parallel-resonant, fundamental mode crystal with a frequency range of 10MHz - 54MHz

The oscillator input also supports being driven by a single-ended crystal oscillator or reference clock.

The initial holdover frequency offset is set by the device, but the long term drift depends on the quality of the crystal or oscillator attached to this port.

Bypass Path

The crystal input, CLK0 or CLK1 may be used directly as a clock source for the Q[3] output divider. This may only be done for input frequencies of 250MHz or less.

Input Clock Selection

The 8T49N240 accepts up to two input clocks with frequencies ranging from 8kHz up to 875MHz. Each input can accept LVPECL, LVDS, LVHSTL, HCSL or LVCMOS inputs using 1.8V, 2.5V or 3.3V logic levels.

In Manual mode, only one of the inputs may be chosen and if that input fails that PLL will enter holdover.

Manual mode may be operated by directly selecting the desired input reference in the REFSEL register field. It may also operate via pin-selection of the desired input clock by selecting that mode in the REFSEL register field. In that case, GPIO[2] must be used as a Clock Select input (CSEL). CSEL = 0 will select the CLK0 input and CSEL = 1 will select the CLK1 input.

In addition, the crystal frequency may be passed directly to the output divider Q[3] for use as a reference.

Inputs do not support transmission of spread-spectrum clocking sources. Since this family is intended for high-performance applications, it will assume input reference sources to have stabilities of ± 100 ppm or better, except where gapped clock inputs are used.

If the PLL is working in automatic mode, then one of the input reference sources is assigned as the higher priority. At power-up or if the currently selected input reference fails, the PLL will switch to the highest priority input reference that is valid at that time (see Input Clock Monitor section for details).

Automatic mode has two sub-options: revertive or non-revertive. In revertive mode, the PLL will switch to a reference with a higher priority setting whenever one becomes valid. In non-revertive mode the PLL remains with the currently selected source as long as it remains valid.

The clock input selection is based on the input clock priority set by the Clock Input Priority control bit.

Input Clock Monitor

Each clock input is monitored for Loss of Signal (LOS). If no activity has been detected on the clock input within a user-selectable time period then the clock input is considered to be failed and an internal Loss-of-Signal status flag is set, which may cause an input switchover depending on other settings. The user-selectable time period has sufficient range to allow a gapped clock missing many consecutive edges to be considered a valid input.

User-selection of the clock monitor time-period is based on a counter driven by a monitor clock. The monitor clock is fixed at the frequency of the PLL's VCO divided by 8. With a VCO range of 2.44GHz - 2.6GHz, the monitor clock has a frequency range of 305MHz to 325MHz.

The monitor logic for each input reference will count the number of monitor clock edges indicated in the appropriate Monitor Control register. If an edge is received on the input reference being monitored, then the count resets and begins again. If the target edge count is reached before an input reference edge is received, then an internal soft alarm is raised and the count re-starts. During the soft alarm period, the PLL tracking will not be adjusted. If an input reference edge is received before the count expires for the second time, then the soft alarm status is cleared and the PLL will resume adjustments. If the count expires again without any input reference edge being received, then a Loss-of-Signal alarm is declared.

It is expected that for normal (non-gapped) clock operation, users will set the monitor clock count for each input reference to be slightly longer than the nominal period of that input reference. A margin of 2-3 monitor clock periods should give a reasonably quick reaction time and yet prevent false alarms.

For gapped clock operation, the user will set the monitor clock count to a few monitor clock periods longer than the longest expected clock gap period. The monitor count registers support 17-bit count values, which will support at least a gap length of two clock periods for any supported input reference frequency, with longer gaps being supported for faster input reference frequencies.

Using this configuration for a gapped clock, the PLL will continue to adjust while the normally expected gap is present, but will freeze once the expected gap length has been exceeded and alarm after twice the normal gap length has passed.

Once a LOS on any of the input clocks is detected, the appropriate internal LOS alarm will be asserted and it will remain asserted until that input clock returns and is validated. Validation occurs once 8 rising edges have been received on that input reference. If another error condition on the same input clock is detected during the validation time then the alarm remains asserted and the validation period starts over.

Each LOS flag may also be reflected on one of the GPIO[2:1] outputs. Changes in status of any reference can also generate an interrupt if not masked.

Holdover

8T49N240 supports a small initial holdover frequency offset in non-gapped clock mode. When the input clock monitor is set to support gapped clock operation, this initial holdover frequency offset is indeterminate since the desired behavior with gapped clocks is for the PLL to continue to adjust itself even if clock edges are missing. In gapped clock mode, the PLL will not enter holdover until the input is missing for two LOS monitor periods.

The holdover performance characteristics of a clock are referred as its accuracy and stability, and are characterized in terms of the fractional frequency offset. The 8T49N240 can only control the initial frequency accuracy. Longer-term accuracy and stability are determined by the accuracy and stability of the external oscillator.

When the PLL loses all valid input references, it will enter the holdover state. In fast average mode, the PLL will initially maintain its most recent frequency offset setting and then transition at a rate dictated by its selected phase-slope limit setting to a frequency offset setting that is based on historical settings. This behavior is intended to compensate for any frequency drift that may have occurred on the input reference before it was detected to be lost.

The historical holdover value will have three options:

- Return to center of tuning range within the VCO band.
- Instantaneous mode - the holdover frequency will use the DPLL current frequency 100msec before it entered holdover. The accuracy is shown in the *AC Characteristics Table, Table 36*.
- Fast average mode - an internal IIR (Infinite Impulse Response) filter is employed to get the frequency offset. The IIR filter gives a 3dB attenuation point corresponding to nominal a period of 20 minutes. The accuracy is shown in the *AC Characteristics Table, Table 36*.

When entering holdover, the PLL will set a separate internal HOLD alarm internally. This alarm may be read from internal status register, appear on the appropriate GPIO pin and/or assert the nINT output.

While the PLL is in holdover, its frequency offset is now relative to the crystal input and so the output clocks will be tracing their accuracy to the local oscillator or crystal. At some point in time, depending on the stability and accuracy of that source, the clock(s) will have drifted outside of the limits of the holdover state and be considered to be in a free-run state. Since this borderline is defined outside the PLL and dictated by the accuracy and stability of the external local crystal or oscillator, the 8T49N240 cannot know or influence when that transition occurs.

Input to Output Clock Frequency

The 8T49N240 is designed to accept any frequency within its input range and generate four different output frequencies that are integer-related to the PLL frequency and hence to each other, but not to the input frequencies. The internal architecture of the device ensures that most translations will result in the exact output frequency specified. Please contact IDT for configuration software or other assistance in determining if a desired configuration will be supported exactly.

Synthesizer Mode Operation

The device may act as a frequency synthesizer with the PLL generating its operating frequency from just the crystal input. By setting the SYN_MODE register bit and setting the STATE[1:0] field to Free-run, no input clock references are required to generate the desired output frequencies.

When operating as a synthesizer, the precision of the output frequency will be < 20ppb for any supported configuration.

Loop Filter and Bandwidth

The 8T49N240 uses two external capacitors of fixed value to support its loop bandwidth. When operating in Synthesizer mode a fixed loop bandwidth of approximately 200kHz is provided.

When not operating as a synthesizer, the 8T49N240 will support a range of loop bandwidths: 0.2Hz, 0.4Hz, 0.8Hz, 1.6Hz, 3.2Hz, 6.4Hz, 12Hz, 25Hz, 50Hz, 100Hz, 200Hz, 400Hz, 800Hz, 1.6kHz or 6.4kHz.

The device supports two different loop bandwidth settings: acquisition and locked. These loop bandwidths are selected from the list of options described above. If enabled, the acquisition bandwidth is used while lock is being acquired to allow the PLL to 'fast-lock'. Once locked the PLL will use the locked bandwidth setting. If the acquisition bandwidth setting is not used, the PLL will use the locked bandwidth setting at all times.

Integer Output Dividers (Q0, Q1 or Q2)

Each integer output divider block (Q0, Q1 or Q2) allows one of several fixed divide ratios to be chosen. Odd divide ratios of 3 or 5, along with all even divide ratios from 4 to 160 are supported for each output. There is an independent divider block for each output, but each is taking its input frequency directly from the single PLL. The PLL has a frequency range of 2.44GHz to 2.6GHz. The divide ratios, settings and possible output frequencies are shown in [Table 3](#).

Table 3. Output Divide Ratios

Divide Ratio	Minimum F _{OUT} (MHz)	Maximum F _{OUT} (MHz)
3	813.33	866.67
4	610	650
5	488	520
6	406.67	433.33
8	305	325
10	244	260
...		
160	15.25	16.25

Fractional Output Divider Programming (Q3 Only)

For the FracN output divider Q[3], the output divide ratio is given by:

- Output Divide Ratio = (N.F)x2
- N = Integer Part: 4, 5, ... $(2^{18}-1)$
- F = Fractional Part: $[0, 1, 2, \dots, (2^{28}-1)]/(2^{28})$

For integer operation of this output dividers, N = 3 is also supported for the full output frequency range.

Output Divider Frequency Sources

Output dividers associated with the Q[0:2] outputs take their input frequency directly from the PLL.

The output divider associated with the Q[3] output can take its input frequency from the PLL, the CLK0 or CLK1 input reference frequency or the crystal frequency.

Output Phase Control on Switchover

There are two options on how the output phase can be controlled when the 8T49N240 enters or leaves the holdover state, or the PLL switches between input references. Phase-slope limiting or fully hitless switching (sometimes called phase build-out) may be selected. The SWMODE bit selects which behavior is to be followed.

If fully hitless switching is selected, then the output phase will remain unchanged under any of these conditions. Note that fully hitless switching is not supported when external loop-back is being used.

If phase-slope limiting is selected, then the output phase will adjust from its previous value until it is tracking the new condition at a rate dictated by the SLEW[1:0] bits.

Output Drivers

The Q0 to Q3 clock outputs are provided with register-controlled output drivers. By selecting the output drive type in the appropriate register, any of these outputs can support LVPECL, HCSL or LVDS logic levels.

In addition, the Q3 output can support LVCMOS operation. Please refer to the section below for behavior if this option is selected for Q3.

The operating voltage ranges of each output is determined by its independent output power pin (V_{CCO}) and thus each can have different output voltage levels. Output voltage levels of 2.5V or 3.3V are supported for differential operation and LVCMOS operation. In addition, LVCMOS output operation supports 1.8V V_{CCO} .

Each output may be enabled or disabled by register bits and/or GPIO pins.

LVCMOS Operation (Q3 Only)

When the Q3 output is configured to provide LVCMOS levels, then both the Q and nQ outputs will toggle at the selected output frequency. All the previously described configuration and control apply equally to both outputs. Frequency, voltage levels and enable / disable status apply to both the Q and nQ pins. When configured as LVCMOS, the Q and nQ outputs can be selected to be phase-aligned with each other or inverted relative to one another. Selection of phase-alignment may have negative effects on the phase noise performance of any part of the device due to increased simultaneous switching noise within the device.

Power-Saving Modes

To allow the device to consume the least power possible for a given application, the following functions are included under register control:

- Any unused output, including all output divider logic, can be individually powered-off.
- Any unused input, including the clock monitoring logic can be individually powered-off.
- The digital PLL can be powered-off when running in synthesizer mode.
- Clock gating on logic that is not being used.

Status / Control Signals and Interrupts

The status and control signals for the device, may be operated at 1.8V, 2.5V or 3.3V as determined by the voltage applied to the V_{CCCS} pin. All signals will share the same voltage levels.

Signals involved include: nINT, nRST, GPIO[3:0], S_A0, S_A1, SCLK and SDATA. The voltage used here is independent of the voltage chosen for the digital and analog core voltages and the output voltages selected for the clock outputs.

General-Purpose I/Os and Interrupts

The 8T49N240 provides four General Purpose Input / Output (GPIO) pins for miscellaneous status and control functions. Each GPIO may be configured as either an input or an output. Each GPIO may be directly controlled from register bits or be used as a predefined function as shown in Table 4. Note that the default state prior to configuration being loaded from internal OTP will be to set each GPIO to input direction to function as an Output Enable.

Table 4. GPIO Configuration

GPIO Pin	Configured as Input		Configured as Output	
	Fixed Function (default)	General Purpose	Fixed Function	General Purpose
3	-	GPI[3]	LOL	GPO[3]
2	CSEL	GPI[2]	LOS[0]	GPO[2]
1	OSEL[1]	GPI[1]	LOS[1]	GPO[1]
0	OSEL[0]	GPI[0]	HOLD	GPO[0]

If used in the Fixed Function mode of operation, the GPIO bits will reflect the real-time status of their respective status bits as shown in Table 4.

The LOL alarm will support two modes of operation:

- De-asserts once PLL is locked, or
- De-asserts after PLL is locked and all internal synchronization operations that may destabilize output clocks are completed.

Interrupt Functionality

Interrupt functionality includes an interrupt status flag for each of PLL Loss-of-Lock status (LOL), PLL in holdover status (HOLD) and Loss-of-Signal status for each input (LOS[1:0]). Those Status Flags are set whenever there is an alarm on their respective functions. The Status Flag will remain set until the alarm has been cleared and a '1' has been written to the Status Flag's register location or if a reset occurs. Each Status Flag will also have an Interrupt Enable bit that will determine if that Status Flag is allowed to cause the Device Interrupt Status to be affected (enabled) or not (disabled). All Interrupt Enable bits will be in the disabled state after reset. The Device Interrupt Status Flag and nINT output pin are asserted if any of the enabled interrupt Status Flags are set.

Output Enable Operation

When GPIO[1:0] are used as Output Enable control signals, the function of the pins is to select one of four register-based maps that indicate which outputs should be enabled or disabled.

Figure 2. Output Enable Map Operation

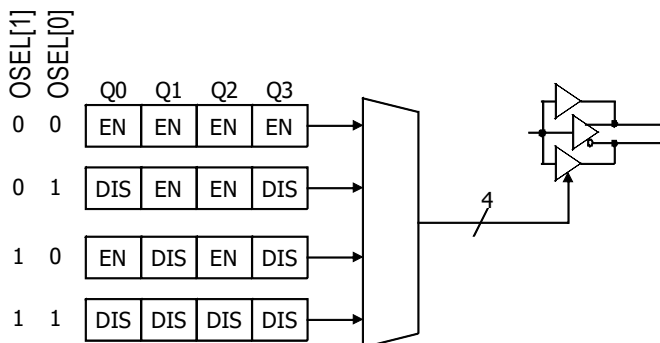

In order to enable a clock output x (x = 0, 1, 2, or 3), three conditions must be met:

- The output must be powered (Qx_DIS = 0).
- The output must be enabled via registers (OUTEN[x] = 1).
- If the GPIO[1:0] are configured as OSEL[1:0] respectively, the output enable select pins (OSEL[1:0]) must select an output enable map that enables output x (see [Figure 2](#)).

Device Hardware Configuration

The 8T49N240 supports an internal One-Time Programmable (OTP) memory that can be pre-programmed at the factory with one complete device configuration. Some or all of this pre-programmed configuration will be loaded into the device's registers on power-up or reset.

These default register settings can be over-written using the serial programming interface once reset is complete. Any configuration written via the serial programming interface needs to be re-written after any power cycle or reset. Please contact IDT if a specific factory-programmed configuration is desired.

Device Start-up and Reset Behavior

The 8T49N240 has an internal power-up reset (POR) circuit and a Master Reset input pin nRST. If either is asserted, the device will be in the Reset State.

While in the reset state (nRST input asserted or POR active), the device will operate as follows:

- All registers will return to and be held in their default states as indicated in the applicable register description.
- All internal state machines will be in their reset conditions.
- The serial interface will not respond to read or write cycles.
- The GPIO signals will be configured as Output Enable inputs.
- All clock outputs will be disabled.
- All interrupt status and Interrupt Enable bits will be cleared, negating the nINT signal.

Upon the later of the internal POR circuit expiring or the nRST input negating, the device will exit reset and begin self-configuration.

The device will load an initial block of its internal registers using the configuration stored in the internal One-Time Programmable (OTP) memory. Once this step is complete, the 8T49N240 will check the register settings to see if it should load the remainder of its configuration from an external I²C EEPROM at a defined address or continue loading from OTP, or both. See the section on I²C Boot Initialization for details on how this is performed.

Once the full configuration has been loaded, the device will respond to accesses on the serial port and will attempt to lock the PLL to the crystal and begin operation. Once the PLL is locked, all the outputs derived from it will be synchronized.

Serial Control Port Description

Serial Control Port Configuration Description

The device has a serial control port capable of responding as a slave in an I²C compatible configuration, to allow access to any of the internal registers for device programming or examination of internal status. All registers are configured to have default values. See the specifics for each register for details.

The device has the additional capability of becoming a master on the I²C bus only for the purpose of reading its initial register configurations from a serial EEPROM on the I²C bus. Writing of the configuration to the serial EEPROM must be performed by another device on the same I²C bus or pre-programmed into the device prior to assembly.

I²C Mode Operation

The I²C interface is designed to fully support v2.1 of the I²C Specification for Normal and Fast mode operation. The device acts as a slave device on the I²C bus at 100kHz or 400kHz using the address defined in the Serial Interface Control register (0006h), as modified by the S_A0 and S_A1 input pin settings. The interface accepts byte-oriented block write and block read operations. Two address bytes specify the register address of the byte position of the first register to write or read. Data bytes (registers) are accessed in sequential order from the lowest to the highest byte (most significant bit first). Read and write block transfers can be stopped after any complete byte transfer. During a write operation, data will not be moved into the registers until the STOP bit is received, at which point, all data received in the block write will be written simultaneously.

For full electrical I²C compliance, it is recommended to use external pull-up resistors for SDATA and SCLK. The internal pull-up resistors have a size of 51kΩ typical.

Figure 3. I²C Slave Read and Write Cycle Sequencing

Current Read

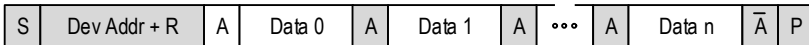

Sequential Read



Sequential Write

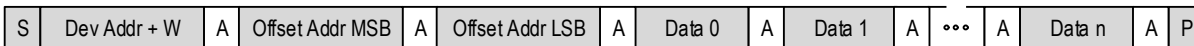

- From master to slave
- From slave to master
- S = Start
- Sr = Repeated start
- A = Acknowledge
- A-bar = Non-acknowledge
- P = Stop

I²C Master Mode

When operating in I²C mode, the 8T49N240 has the capability to become a bus master on the I²C bus for the purposes of reading its configuration from an external I²C EEPROM. Only a block read cycle will be supported.

As an I²C bus master, the 8T49N240 will support the following functions:

- 7-bit addressing mode
- Base address register for EEPROM
- Validation of the read block via CCITT-8 CRC check against value stored in last byte (84h) of EEPROM
- Support for 100kHz and 400kHz operation with speed negotiation. If bit d0 is set at Byte address 05h in the EEPROM, this will shift from 100kHz operation to 400kHz operation.
- Support for 1- or 2-byte addressing mode
- Master arbitration with programmable number of retries
- Fixed-period cycle response timer to prevent permanently hanging the I²C bus.
- Read will abort with an alarm (BOOTFAIL) if any of the following conditions occur: Slave NACK, Arbitration Fail, Collision during Address Phase, CRC failure, Slave Response time-out

The 8T49N240 will not support the following functions:

- I²C General Call
- Slave clock stretching
- I²C Start Byte protocol
- EEPROM Chaining
- CBUS compatibility
- Responding to its own slave address when acting as a master
- Writing to external I²C devices including the external EEPROM used for booting

Figure 4. I²C Master Read Cycle Sequencing

Sequential Read (1-Byte Offset Address)

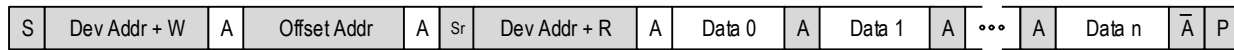

Sequential Read (2-Byte Offset Address)



- | | | |
|--------------------------|----------------------|-----------------------------|
| <input type="checkbox"/> | From master to slave | S = Start |
| <input type="checkbox"/> | From slave to master | Sr = Repeated start |
| | | A = Acknowledge |
| | | \bar{A} = Non-acknowledge |
| | | P = Stop |

I²C Boot-up Initialization Mode

If enabled (via the BOOT_EEP bit in the Startup register), once the nRST input has been de-asserted (high) and its internal power-up reset sequence has completed, the device will contend for ownership of the I²C bus to read its initial register settings from a memory location on the I²C bus. The address of that memory location is kept in non-volatile memory in the Startup register. During the boot-up process, the device will not respond to serial control port accesses. Once the initialization process is complete, the contents of any of the device's registers can be altered. It is the responsibility of the user to make any desired adjustments in initial values directly in the serial bus memory.

If a NACK is received to any of the read cycles performed by the device during the initialization process, or if the CRC does not match the one stored in address 84h of the EEPROM the process will be aborted and any uninitialized registers will remain with their default values. The BOOTFAIL bit in the Global Interrupt Status register (0210h) will also be set in this event.

Contents of the EEPROM should be as shown in [Table 5](#).

Table 5. External Serial EEPROM Contents

EEPROM Offset (Hex)	Contents							
	D7	D6	D5	D4	D3	D2	D1	D0
00	1	1	1	1	1	1	1	1
01	1	1	1	1	1	1	1	1
02	1	1	1	1	1	1	1	1
03	1	1	1	1	1	1	1	1
04	1	1	1	1	1	1	1	1
05	1	1	1	1	1	1	1	Serial EEPROM Speed Select 0 = 100kHz 1 = 400kHz
06	1	8T49N240 Device I ² C Address [6:2]					1	1
07	0	0	0	0	0	0	0	0
08 - 83	Desired contents of Device Registers 08h - 83h							
84	Serial EEPROM CRC							
85 - FF	Unused							

Register Descriptions

Table 6. Register Blocks

Register Ranges Offset (Hex)	Register Block Description
0000–0001	Startup Control Registers
0002–0005	Device ID Control Registers
0006–0007	Serial Interface Control Registers
0008–002F	Digital PLL Control Registers
0030–0038	GPIO Control Registers
0039–003E	Output Driver Control Registers
003F–004A	Output Divider Control Registers (Integer Portion)
004B–0056	Reserved
0057–0062	Output Divider Control Registers (Fractional Portion)
0063–0067	Output Divider Source Control Registers
0068–006C	Analog PLL Control Registers
006D–0070	Power-Down and Lock Alarm Control Registers
0071–0078	Input Monitor Control Registers
0079	Interrupt Enable Register
007A–007B	Reserved
007C–01FF	Reserved
0200–0201	Interrupt Status Registers
0202–020B	Reserved
020C	General-Purpose Input Status Register
020D–0211	Global Interrupt and Boot Status Register
0212–03FF	Reserved

Table 7. Startup Control Register Bit Field Locations and Descriptions

Startup Control Register Block Field Locations									
Address (Hex)	D7	D6	D5	D4	D3	D2	D1	D0	
0000	EEP_RTY[4:0]					Rsvd	nBOOT_OTP	nBOOT_EEP	
0001	EEP_A15	EEP_ADDR[6:0]							

Startup Control Register Block Field Descriptions			
Bit Field Name	Field Type	Default Value	Description
EEP_RTY[4:0]	R/W	1h	Select number of times arbitration for the I ² C bus to read the serial EEPROM will be retried before being aborted. Note that this number does not include the original try.
nBOOT_OTP	R/W	NOTE ^[a]	Internal One-Time Programmable (OTP) memory usage on power-up: 0 = Load power-up configuration from OTP 1 = Only load 1st eight bytes from OTP
nBOOT_EEP	R/W	NOTE ^a	External EEPROM usage on power-up: 0 = Load power-up configuration from external serial EEPROM (overwrites OTP values) 1 = Don't use external EEPROM
EEP_A15	R/W	NOTE ^a	Serial EEPROM supports 15-bit addressing mode (multiple pages).
EEP_ADDR[6:0]	R/W	NOTE ^a	I ² C base address for serial EEPROM.
Rsvd	R/W	-	Reserved. Always write 0 to this bit location. Read values are not defined.

[a] These values are specific to the device configuration and can be customized when ordering. Please refer to the FemtoClock® NG Universal Frequency Translator Ordering Product Information guide for exact default values.

Table 8. Device ID Control Register Bit Field Locations and Descriptions

Device ID Register Control Block Field Locations								
Address (Hex)	D7	D6	D5	D4	D3	D2	D1	D0
0002	REV_ID[3:0]				DEV_ID[15:12]			
0003	DEV_ID[11:4]							
0004	DEV_ID[3:0]				DASH_CODE [10:7]			
0005	DASH_CODE [6:0]							1

Device ID Control Register Block Field Descriptions			
Bit Field Name	Field Type	Default Value	Description
REV_ID[3:0]	R/W	0h	Device revision.
DEV_ID[15:0]	R/W	060Ch	Device ID code.
DASH CODE [10:0]	R/W	NOTE ^[a]	Device Dash code. Decimal value assigned by IDT to identify the configuration loaded at the factory. May be over-written by users at any time.

[a] These values are specific to the device configuration and can be customized when ordering. Please refer to the FemtoClock® NG Universal Frequency Translator Ordering Product Information guide for exact default values.

Table 9. Serial Interface Control Register Bit Field Locations and Descriptions

Serial Interface Control Block Field Locations								
Address (Hex)	D7	D6	D5	D4	D3	D2	D1	D0
0006	Rsvd	UFTADD[6:2]					UFTADD[1]	UFTADD[0]
0007	Rsvd							Rsvd

Serial Interface Control Register Block Field Descriptions			
Bit Field Name	Field Type	Default Value	Description
UFTADD[6:2]	R/W	NOTE ^[a]	Configurable portion of I ² C base address for this device.
UFTADD[1]	R/O	0b	I ² C base address bit 1. See Table 1 . This address bit reflects the status of the S_A1 external input pin.
UFTADD[0]	R/O	0b	I ² C base address bit 0. This address bit reflects the status of the S_A0 external input pin. See Table 1 .
Rsvd	R/W	-	Reserved. Always write 0 to this bit location. Read values are not defined.

[a] These values are specific to the device configuration 'dash-code'. Please refer to the *FemtoClock NG Universal Frequency Translator Ordering Product Information guide* for exact default values.

Table 10. Digital PLL Input Control Register Bit Field Locations and Descriptions

Digital PLL Input Control Register Block Field Locations								
Address (Hex)	D7	D6	D5	D4	D3	D2	D1	D0
0008	REFSEL[2:0]			FBSEL[2:0]			RVRT	SWMODE
0009	Rsvd							REF_PRI
000A	Rsvd	REFDIS1	REFDIS0	Rsvd	Rsvd	STATE[1:0]		
000B	Rsvd			PRE0[20:16]				
000C	PRE0[15:8]							
000D	PRE0[7:0]							
000E	Rsvd			PRE1[20:16]				
000F	PRE1[15:8]							
0010	PRE1[7:0]							

Digital PLL Input Control Register Block Field Descriptions			
Bit Field Name	Field Type	Default Value	Description
REFSEL[2:0]	R/W	000b	Input reference selection for Digital PLL: 000 = Automatic selection 001 = Manual selection by GPIO input 010 through 011 = Reserved 100 = Force selection of Input Reference 0 101 = Force selection of Input Reference 1 110 = Do not use 111 = Do not use
FBSEL[2:0]	R/W	000b	Feedback mode selection for Digital PLL: 000 through 011 = internal feedback divider 100 = external feedback from Input Reference 0 101 = external feedback from Input Reference 1 110 = do not use 111 = do not use
RVRT	R/W	1b	Automatic switching mode for Digital PLL: 0 = non-revertive switching 1 = revertive switching
SWMODE	R/W	1b	Controls how Digital PLL adjusts output phase when switching between input references: 0 = Absorb any phase differences between old and new input references 1 = Track to follow new input reference's phase using phase-slope limiting
REF_PRI	R/W	0b	Switchover priority for Input References when used by Digital PLL: 0 = CLK0 is primary input reference 1 = CLK1 is primary input reference
REFDIS1	R/W	0b	Input Reference 1 Switching Selection Disable for Digital PLL: 0 = Input Reference 1 is included in the switchover sequence 1 = Input Reference 1 is not included in the switchover sequence

Digital PLL Input Control Register Block Field Descriptions

Bit Field Name	Field Type	Default Value	Description
REFDIS0	R/W	0b	Input Reference 0 Switching Selection Disable for Digital PLL: 0 = Input Reference 0 is included in the switchover sequence 1 = Input Reference 0 is not included in the switchover sequence
STATE[1:0]	R/W	00b	Digital PLL State Machine Control: 00 = Run automatically 01 = Force FREERUN state - set this if in Synthesizer Mode. 10 = Force NORMAL state 11 = Force HOLDOVER state
PRE0[20:0]	R/W	000000h	Pre-divider ratio for Input Reference 0 when used by Digital PLL.
PRE1[20:0]	R/W	000000h	Pre-divider ratio for Input Reference 1 when used by Digital PLL.
Rsvd	R/W	-	Reserved. Always write 0 to this bit location. Read values are not defined.

Table 11. Digital PLL Feedback Control Register Bit Field Locations and Descriptions

Digital PLL Feedback Control Register Block Field Locations									
Address (Hex)	D7	D6	D5	D4	D3	D2	D1	D0	
0011	M1_0[23:16]								
0012	M1_0[15:8]								
0013	M1_0[7:0]								
0014	M1_1[23:16]								
0015	M1_1[15:8]								
0016	M1_1[7:0]								
0017	LCKBW[3:0]				ACQBW[3:0]				
0018	LCKDAMP[2:0]			ACQDAMP[2:0]			PLLGAIN[1:0]		
0019	Rsvd			Rsvd	Rsvd			Rsvd	
001A	Rsvd								
001B	Rsvd								
001C	Rsvd							Rsvd	
001D	Rsvd								
001E	Rsvd								
001F	FFh								
0020	FFh								
0021	FFh								
0022	FFh								
0023	SLEW[1:0]	Rsvd	HOLD[1:0]		Rsvd	HOLDAVG	FASTLCK		
0024	LOCK[7:0]								
0025	Rsvd							DSM_INT[8]	
0026	DSM_INT[7:0]								
0027	Rsvd								
0028	Rsvd			DSMFRAC[20:16]					
0029	DSMFRAC[15:8]								
002A	DSMFRAC[7:0]								
002B	00h								
002C	01h								
002D	Rsvd								
002E	Rsvd								
002F	DSM_ORD[1:0]		DCXOGAIN[1:0]		Rsvd	DITHGAIN[2:0]			

Digital PLL Feedback Configuration Register Block Field Descriptions

Bit Field Name	Field Type	Default Value	Description
M1_0[23:0]	R/W	070000h	M1 Feedback divider ratio for Input Reference 0 when used by Digital PLL.
M1_1[23:0]	R/W	070000h	M1 Feedback divider ratio for Input Reference 1 when used by Digital PLL.
LCKBW[3:0]	R/W	0111b	Digital PLL Loop Bandwidth while locked: 0000 = 0.2Hz 0001 = 0.4Hz 0010 = 0.8Hz 0011 = 1.6Hz 0100 = 3.2Hz 0101 = 6.4Hz 0110 = 12Hz 0111 = 25Hz 1000 = 50Hz 1001 = 100Hz 1010 = 200Hz 1011 = 400Hz 1100 = 800Hz 1101 = 1.6kHz 1110 = 6.4kHz 1111 = Reserved
ACQBW[3:0]	R/W	0111b	Digital PLL Loop Bandwidth while in acquisition (not-locked): 0000 = 0.2Hz 0001 = 0.4Hz 0010 = 0.8Hz 0011 = 1.6Hz 0100 = 3.2Hz 0101 = 6.4Hz 0110 = 12Hz 0111 = 25Hz 1000 = 50Hz 1001 = 100Hz 1010 = 200Hz 1011 = 400Hz 1100 = 800Hz 1101 = 1.6kHz 1110 = 6.4kHz 1111 = Reserved

Digital PLL Feedback Configuration Register Block Field Descriptions

Bit Field Name	Field Type	Default Value	Description
LCKDAMP[2:0]	R/W	011b	Damping factor for Digital PLL while locked: 000 = Reserved 001 = 1 010 = 2 011 = 5 100 = 10 101 = 20 110 = Reserved 111 = Reserved
ACQDAMP[2:0]	R/W	011b	Damping factor for Digital PLL while in acquisition (not locked): 000 = Reserved 001 = 1 010 = 2 011 = 5 100 = 10 101 = 20 110 = Reserved 111 = Reserved
PLLGAIN[1:0]	R/W	01b	Digital Loop Filter Gain Settings for Digital PLL: 00 = 0.5 01 = 1 10 = 1.5 11 = 2
SLEW[1:0]	R/W	00b	Phase-slope control for Digital PLL: 00 = no limit - controlled by loop bandwidth of Digital PLL 01 = 64us/s 10 = 11us/s 11 = Reserved
HOLD[1:0]	R/W	00b	Holdover Averaging mode selection for Digital PLL: 00 = Instantaneous mode - uses historical value 100ms prior to entering holdover 01 = Fast Average Mode 10 = Reserved 11 = Return to Center of VCO Tuning Range
HOLDAVG	R/W	0b	Holdover Averaging Enable for Digital PLL: 0 = Holdover averaging disabled 1 = Holdover averaging enabled as defined in HOLD[1:0]
FASTLCK	R/W	0b	Enables Fast Lock operation for Digital PLL: 0 = Normal locking using LCKBW and LCKDAMP fields in all cases 1 = Fast Lock mode using ACQBW and ACQDAMP when not phase locked and LCKBW and LCKDAMP once phase locked
LOCK[7:0]	R/W	3Fh	Lock window size for Digital PLL. Unsigned 2's complement binary number in steps of 2.5ns, giving a total range of 640ns. Do not program to 0.
DSM_INT[8:0]	R/W	02Dh	Integer portion of the Delta-Sigma Modulator value.

Digital PLL Feedback Configuration Register Block Field Descriptions

Bit Field Name	Field Type	Default Value	Description
DSMFRAC[20:0]	R/W	000000h	Fractional portion of Delta-Sigma Modulator value. Divide this number by 2^{21} to determine the actual fraction.
DSM_ORD[1:0]	R/W	11b	Delta-Sigma Modulator Order for Digital PLL: 00 = Delta-Sigma Modulator disabled 01 = 1st order modulation 10 = 2nd order modulation 11 = 3rd order modulation
DCXOGAIN[1:0]	R/W	01b	Multiplier applied to instantaneous frequency error before it is applied to the Digitally Controlled Oscillator in Digital PLL: 00 = 0.5 01 = 1 10 = 2 11 = 4
DITHGAIN[2:0]	R/W	000b	Dither Gain setting for Digital PLL: 000 = no dither 001 = Least Significant Bit (LSB) only 010 = 2 LSBs 011 = 4 LSBs 100 = 8 LSBs 101 = 16 LSBs 110 = 32 LSBs 111 = 64 LSBs
Rsvd	R/W	-	Reserved. Always write 0 to this bit location. Read values are not defined.

Table 12. GPIO Control Register Bit Field Locations and Descriptions

The values observed on any GPIO pins that are used as general purpose inputs are visible in the GPI[3:0] register that is located at location 0x020C near a number of other read-only registers.

GPIO Control Register Block Field Locations								
Address (Hex)	D7	D6	D5	D4	D3	D2	D1	D0
0030	Rsvd				GPIO_DIR[3:0]			
0031	Rsvd				GPI3SEL[2]	GPI2SEL[2]	GPI1SEL[2]	GPI0SEL[2]
0032	Rsvd				GPI3SEL[1]	GPI2SEL[1]	GPI1SEL[1]	GPI0SEL[1]
0033	Rsvd				GPI3SEL[0]	GPI2SEL[0]	GPI1SEL[0]	GPI0SEL[0]
0034	Rsvd				GPO3SEL[2]	GPO2SEL[2]	GPO1SEL[2]	GPO0SEL[2]
0035	Rsvd				GPO3SEL[1]	GPO2SEL[1]	GPO1SEL[1]	GPO0SEL[1]
0036	Rsvd				GPO3SEL[0]	GPO2SEL[0]	GPO1SEL[0]	GPO0SEL[0]
0037	Rsvd							
0038	Rsvd				GPO[3:0]			

GPIO Control Register Block Field Descriptions			
Bit Field Name	Field Type	Default Value	Description
GPIO_DIR[3:0]	R/W	0000b	Direction control for General-Purpose I/O Pins GPIO[3:0]: 0 = input mode 1 = output mode
GPI3SEL[2:0]	R/W	001b	Function of GPIO[3] pin when set to input mode by GPIO_DIR[3] register bit: 000 = General Purpose Input (value on GPIO[3] pin directly reflected in GPI[3] register bit) 001 = reserved 010 = reserved 011 = reserved 100 through 111 = reserved
GPI2SEL[2:0]	R/W	001b	Function of GPIO[2] pin when set to input mode by GPIO_DIR[2] register bit: 000 = General Purpose Input (value on GPIO[2] pin directly reflected in GPI[2] register bit) 001 = CSEL: Manual Clock Select Input for PLL 010 = reserved 011 = reserved 100 = reserved 101 through 111 = reserved
GPI1SEL[2:0]	R/W	001b	Function of GPIO[1] pin when set to input mode by GPIO_DIR[1] register bit: 000 = General Purpose Input (value on GPIO[1] pin directly reflected in GPI[1] register bit) 001 = Output Enable control bit 1: OSEL[1] 010 through 111 = reserved

GPIO Control Register Block Field Descriptions

Bit Field Name	Field Type	Default Value	Description
GPIOSEL[2:0]	R/W	001b	Function of GPIO[0] pin when set to input mode by GPIO_DIR[0] register bit: 000 = General Purpose Input (value on GPIO[0] pin directly reflected in GPI[0] register bit) 001 = Output Enable control bit 0: OSEL[0] 010 = reserved 011 = reserved 100 through 111 = reserved
GPO3SEL[2:0]	R/W	000b	Function of GPIO[3] pin when set to output mode by GPIO_DIR[3] register bit: 000 = General Purpose Output (value in GPO[3] register bit driven on GPIO[3] pin) 001 = Loss-of-Lock Status Flag for Digital PLL reflected on GPIO[3] pin 010 = reserved 011 = reserved 100 through 111 = reserved
GPO2SEL[2:0]	R/W	000b	Function of GPIO[2] pin when set to output mode by GPIO_DIR[2] register bit: 000 = General Purpose Output (value in GPO[2] register bit driven on GPIO[2] pin) 001 = Loss-of-Signal Status Flag for Input Reference 0 reflected on GPIO[2] pin 010 = reserved 011 = reserved 100 = reserved 101 through 111 = reserved
GPO1SEL[2:0]	R/W	000b	Function of GPIO[1] pin when set to output mode by GPIO_DIR[1] register bit: 000 = General Purpose Output (value in GPO[1] register bit driven on GPIO[1] pin) 001 = Loss-of-Signal Status Flag for Input Reference 1 reflected on GPIO[1] pin 010 = reserved 011 = reserved 100 = reserved 101 = reserved 110 = reserved 111 = reserved
GPO0SEL[2:0]	R/W	000b	Function of GPIO[0] pin when set to output mode by GPIO_DIR[0] register bit: 000 = General Purpose Output (value in GPO[0] register bit driven on GPIO[0] pin) 001 = Holdover Status Flag for Digital PLL reflected on GPIO[0] pin 010 = reserved 011 = reserved 100 = reserved 101 = reserved 110 through 111 = reserved
GPO[3:0]	R/W	00h	Output Values reflect on pin GPIO[3:0] when General-Purpose Output Mode selected.
Rsvd	R/W	-	Reserved. Always write 0 to this bit location. Read values are not defined.

Table 13. Output Driver Control Register Bit Field Locations and Descriptions

Output Driver Control Register Block Field Locations								
Address (Hex)	D7	D6	D5	D4	D3	D2	D1	D0
0039	Rsvd				OUTEN[3:0]			
003A	Rsvd				POL_Q[3]	Rsvd		
003B	Rsvd							
003C	Rsvd							
003D	OUTMODE3[2:0]			SE_MODE3	OUTMODE2[2:0]			Rsvd
003E	OUTMODE1[2:0]			Rsvd	OUTMODE0[2:0]			Rsvd

Output Driver Control Register Block Field Descriptions			
Bit Field Name	Field Type	Default Value	Description
OUTEN[3:0]	R/W	0000b	Output Enable control for Clock Outputs Q[3:0], nQ[3:0]: 0 = Qn is in a high-impedance state 1 = Qn is enabled as indicated in appropriate OUTMODEn[2:0] register field
POL_Q[3]	R/W	0000b	Polarity of Clock Outputs Q[3], nQ[3]: 0 = Q3 is normal polarity 1 = Q3 is inverted polarity
OUTMODE3[2:0]	R/W	001b	Output Driver Mode of Operation for Clock Output Pair Q3, nQ3: 000 = High-impedance 001 = LVPECL 010 = LVDS 011 = LVCMOS 100 = HCSSL 101 - 111 = reserved
SE_MODE3	R/W	0b	Behavior of Output Pair Q3, nQ3 when LVCMOS operation is selected: (Must be 0 if LVDS or LVPECL output style is selected) 0 = Q3 and nQ3 are both the same frequency but inverted in phase 1 = Q3 and nQ3 are both the same frequency and phase
OUTMODEm[2:0]	R/W	001b	Output Driver Mode of Operation for Clock Output Pair Qm, nQm (m = 0, 1, 2): 000 = High-impedance 001 = LVPECL 010 = LVDS 011 = Reserved 100 = HCSSL 101 - 111 = reserved
Rsvd	R/W	-	Reserved. Always write 0 to this bit location. Read values are not defined.

Table 14. Output Divider Control Register (Integer Portion) Bit Field Locations and Descriptions

Output Divider Control Register (Integer Portion) Block Field Locations									
Address (Hex)	D7	D6	D5	D4	D3	D2	D1	D0	
003F	N_Q0[7:0]								
0040	Rsvd								
0041	Rsvd								
0042	N_Q1[7:0]								
0043	Rsvd								
0044	Rsvd								
0045	N_Q2[7:0]								
0046	Rsvd								
0047	Rsvd								
0048	Rsvd						N_Q3[17:16]		
0049	N_Q3[15:8]								
004A	N_Q3[7:0]								

Output Divider Control Register (Integer Portion) Block Field Descriptions			
Bit Field Name	Field Type	Default Value	Description
N_Qm[7:0]	R/W	03h	1st Stage Output Divider Ratio for Output Clock Qm, nQm (m = 0, 1, 2): 00h - 02h = Do not use 03h - 06h = actual divide ratio (e.g. 03h = /3, A0h = /160) 07h - A0h = even numbers represent actual divide ratio, odd numbers should not be used (07h = Do Not Use, 08h = /8, 09h = Do Not Use, 0Ah = /10, etc.) A1h - FFh = Do not use
N_Q3[17:0]	R/W	20002h	Integer Portion of Output Divider Ratio for Output Clock Q3, nQ3: Values of 0, 1 or 2 cannot be written to this register. Actual divider ratio is 2x the value written here.
Rsvd	R/W	-	Reserved. Always write 0 to this bit location. Read values are not defined.

Table 15. Output Divider Control Register (Fractional Portion) Bit Field Locations and Descriptions (Q3 Only)

Output Divider Control Register (Fractional Portion) Block Field Locations								
Address (Hex)	D7	D6	D5	D4	D3	D2	D1	D0
0057	Rsvd							
0058	Rsvd							
0059	Rsvd							
005A	Rsvd							
005B	Rsvd							
005C	Rsvd							
005D	Rsvd							
005E	Rsvd							
005F	Rsvd				NFRAC_Q3[27:24]			
0060	NFRAC_Q3[23:16]							
0061	NFRAC_Q3[15:8]							
0062	NFRAC_Q3[7:0]							

Output Divider Control Register (Fractional Portion) Block Field Descriptions			
Bit Field Name	Field Type	Default Value	Description
NFRAC_Qm[27:0]	R/W	0000000h	Fractional Portion of Output Divider Ratio for Output Clock Q3, nQ3. Actual fractional portion is 2x the value written here. Fraction = (NFRAC_Qm * 2) * 2 ⁻²⁸
Rsvd	R/W	-	Reserved. Always write 0 to this bit location. Read values are not defined.

Table 16. Output Clock Source Control Register Bit Field Locations and Descriptions

Output Clock Source Control Register Block Field Locations								
Address (Hex)	D7	D6	D5	D4	D3	D2	D1	D0
0063	PLL_SYN	Rsvd	CLK_SEL3[1:0]		Rsvd			
0064	Rsvd							
0065	Rsvd							
0066	Rsvd		Rsvd		Rsvd		Rsvd	
0067	10b		10b		00b		Rsvd	

Output Clock Source Control Register Block Field Descriptions			
Bit Field Name	Field Type	Default Value	Description
PLL_SYN	R/W	0b	Output Synchronization Control for Outputs Derived from PLL. Setting this bit from 0->1 will cause the output divider(s) for the affected outputs to be held in reset. Setting this bit from 1->0 will release all the output divider(s) for the affected outputs to run from the same point in time.
CLK_SEL3[1:0]	R/W	00b	Clock Source Selection for output pair Q3: nQ3. Do not select Input Reference 0 or 1 if that input is faster than 250MHz: 00 = PLL 01 = Input Reference 0 (CLK0) 10 = Input Reference 1 (CLK1) 11 = Crystal input
Rsvd	R/W	-	Reserved. Always write 0 to this bit location. Read values are not defined.

Table 17. Analog PLL Control Register Bit Field Locations and Descriptions

Please contact IDT through one of the methods listed on the last page of this datasheet for details on how to set these fields for a particular user configuration.

Analog PLL Control Register Block Field Locations								
Address (Hex)	D7	D6	D5	D4	D3	D2	D1	D0
0068	Rsvd		RS[2:0]			WPST[1:0]		WPST_BYP
0069	Rsvd		Rsvd	TDC_DIS	SYN_MODE	1	DLCNT	DBITM
006A	VCOMAN[2:0]			DBIT[4:0]				
006B	001b			Rsvd				
006C	Rsvd			CPSET[4:0]				

Analog PLL Control Register Block Field Descriptions			
Bit Field Name	Field Type	Default Value	Description
RS[2:0]	R/W	001b	Internal Loop Filter Series Resistor Setting for Analog PLL: 000 = 98Ω 001 = 107Ω 010 = 131Ω 011 = 168Ω 100 = 235Ω 101 = 294Ω 110 = 588Ω 111 = 1.18kΩ
WPST[1:0]	R/W	01b	Internal Loop Filter 2nd-Pole Setting for Analog PLL: 00 = Rpost = 510Ω, Cpost = 120pF 01 = Rpost = 510Ω, Cpost = 160pF 10 = Rpost = 510Ω, Cpost = 200pF 11 = Rpost = 510Ω, Cpost = 240pF
WPST_BYP	R/W	1b	Internal Loop Filter 2nd-Pole Bypass for Analog PLL: 0 = Loop Filter 2nd-Pole is used 1 = Loop Filter 2nd-Pole is not used
TDC_DIS	R/W	0b	TDC Disable Control for PLL: 0 = TDC Enabled 1 = TDC Disabled
SYN_MODE	R/W	0b	Frequency Synthesizer Mode Control for PLL: 0 = PLL jitter attenuates and translates one or more input references 1 = PLL synthesizes output frequencies using only the crystal as a reference Note that the STATE[1:0] field in the Digital PLL Control Register must be set to Force Freerun state.
DLCNT	R/W	1b	Digital Lock Count Setting for Analog PLL: 0 = Counter is a 16-bit accumulator 1 = Counter is a 20-bit accumulator

Analog PLL Control Register Block Field Descriptions																																			
Bit Field Name	Field Type	Default Value	Description																																
DBITM	R/W	0b	Digital Lock Manual Override Setting for Analog PLL: 0 = Automatic Mode 1 = Manual Mode																																
VCOMAN[2:0]	R/W	001b	Manual Lock Mode VCO Selection Setting for Analog PLL: 000 = VCO0 001 = VCO1 010 - 111 = Reserved																																
DBIT[4:0]	R/W	01011b	Manual Mode Digital Lock Control Setting for VCO in Analog PLL.																																
CPSET[4:0]	R/W	00000b	Charge Pump Current Setting for Analog PLL: <table border="0" style="width: 100%; border-collapse: collapse;"> <tr> <td>00000 = 110 μA</td> <td>01000 = 990 μA</td> <td>10000 = 165 μA</td> <td>11000 = 1485 μA</td> </tr> <tr> <td>00001 = 220 μA</td> <td>01001 = 1100 μA</td> <td>10001 = 330 μA</td> <td>11001 = 1650 μA</td> </tr> <tr> <td>00010 = 330 μA</td> <td>01010 = 1210 μA</td> <td>10010 = 495 μA</td> <td>11010 = 1815 μA</td> </tr> <tr> <td>00011 = 440 μA</td> <td>01011 = 1320 μA</td> <td>10011 = 660 μA</td> <td>11011 = 1980 μA</td> </tr> <tr> <td>00100 = 550 μA</td> <td>01100 = 1430 μA</td> <td>10100 = 825 μA</td> <td>11100 = 2145 μA</td> </tr> <tr> <td>00101 = 660 μA</td> <td>01101 = 1540 μA</td> <td>10101 = 990 μA</td> <td>11101 = 2310 μA</td> </tr> <tr> <td>00110 = 770 μA</td> <td>01110 = 1650 μA</td> <td>10110 = 1155 μA</td> <td>11110 = 2475 μA</td> </tr> <tr> <td>00111 = 880 μA</td> <td>01111 = 1760 μA</td> <td>10111 = 1320 μA</td> <td>11111 = 2640 μA</td> </tr> </table>	00000 = 110 μ A	01000 = 990 μ A	10000 = 165 μ A	11000 = 1485 μ A	00001 = 220 μ A	01001 = 1100 μ A	10001 = 330 μ A	11001 = 1650 μ A	00010 = 330 μ A	01010 = 1210 μ A	10010 = 495 μ A	11010 = 1815 μ A	00011 = 440 μ A	01011 = 1320 μ A	10011 = 660 μ A	11011 = 1980 μ A	00100 = 550 μ A	01100 = 1430 μ A	10100 = 825 μ A	11100 = 2145 μ A	00101 = 660 μ A	01101 = 1540 μ A	10101 = 990 μ A	11101 = 2310 μ A	00110 = 770 μ A	01110 = 1650 μ A	10110 = 1155 μ A	11110 = 2475 μ A	00111 = 880 μ A	01111 = 1760 μ A	10111 = 1320 μ A	11111 = 2640 μ A
00000 = 110 μ A	01000 = 990 μ A	10000 = 165 μ A	11000 = 1485 μ A																																
00001 = 220 μ A	01001 = 1100 μ A	10001 = 330 μ A	11001 = 1650 μ A																																
00010 = 330 μ A	01010 = 1210 μ A	10010 = 495 μ A	11010 = 1815 μ A																																
00011 = 440 μ A	01011 = 1320 μ A	10011 = 660 μ A	11011 = 1980 μ A																																
00100 = 550 μ A	01100 = 1430 μ A	10100 = 825 μ A	11100 = 2145 μ A																																
00101 = 660 μ A	01101 = 1540 μ A	10101 = 990 μ A	11101 = 2310 μ A																																
00110 = 770 μ A	01110 = 1650 μ A	10110 = 1155 μ A	11110 = 2475 μ A																																
00111 = 880 μ A	01111 = 1760 μ A	10111 = 1320 μ A	11111 = 2640 μ A																																
Rsvd	R/W	-	Reserved. Always write 0 to this bit location. Read values are not defined.																																

Table 18. Power Down Control Register Bit Field Locations and Descriptions

Power Down Control Register Block Field Locations									
Address (Hex)	D7	D6	D5	D4	D3	D2	D1	D0	
006D	Rsvd						CLK1_DIS	CLK0_DIS	
006E	Rsvd						LCKMODE	DBL_DIS	
006F	Rsvd				Q3_DIS	Q2_DIS	Q1_DIS	Q0_DIS	
0070	Rsvd					DPLL_DIS	DSM_DIS	CALRST	

Power Down Control Register Block Field Descriptions			
Bit Field Name	Field Type	Default Value	Description
CLKm_DIS	R/W	0b	Disable Control for Input Reference m: 0 = Input Reference m is Enabled 1 = Input Reference m is Disabled
LCKMODE	R/W	0b	Controls the behavior of the LOL alarm de-assertion: 0 = LOL alarm de-asserts once PLL is locked 1 = LOL alarm de-asserts once PLL is locked and output clocks are stable
DBL_DIS	R/W	0b	Controls whether Crystal Input Frequency is Doubled before Being used in PLL: 0 = 2x Actual Crystal Frequency Used 1 = Actual Crystal Frequency Used
Qm_DIS	R/W	0b	Disable Control for Output Qm, nQm: 0 = Output Qm, nQm functions normally 1 = All logic associated with Output Qm, nQm is Disabled and Driver in High-Impedance state
DPLL_DIS	R/W	0b	Disable Control for Digital PLL: 0 = Digital PLL Enabled 1 = Digital PLL Disabled
DSM_DIS	R/W	0b	Disable Control for Delta-Sigma Modulator for Analog PLL: 0 = DSM Enabled 1 = DSM Disabled
CALRST	R/W	0b	Reset Calibration Logic for APLL: 0 = Calibration Logic for APLLm Enabled 1 = Calibration Logic for APLLm Disabled
Rsvd	R/W	-	Reserved. Always write 0 to this bit location. Read values are not defined.

Table 19. Input Monitor Control Register Bit Field Locations and Descriptions

Input Monitor Control Register Block Field Locations								
Address (Hex)	D7	D6	D5	D4	D3	D2	D1	D0
0071	Rsvd							LOS_0[16]
0072	LOS_0[15:8]							
0073	LOS_0[7:0]							
0074	Rsvd							LOS_1[16]
0075	LOS_1[15:8]							
0076	LOS_1[7:0]							
0077	Rsvd							
0078	Rsvd							

Input Monitor Control Register Block Field Descriptions			
Bit Field Name	Field Type	Default Value	Description
LOS_m[16:0]	R/W	1FFFFh	Number of Input Monitoring clock periods before Input Reference m is considered to be missed (soft alarm). Minimum setting is 3.
Rsvd	R/W	-	Reserved. Always write 0 to this bit location. Read values are not defined.

Table 20. Interrupt Enable Control Register Bit Field Locations and Descriptions

Interrupt Enable Control Register Block Field Locations								
Address (Hex)	D7	D6	D5	D4	D3	D2	D1	D0
0079	Rsvd	LOL_EN	Rsvd	HOLD_EN	Rsvd		LOS1_EN	LOS0_EN

Interrupt Enable Control Register Block Field Descriptions			
Bit Field Name	Field Type	Default Value	Description
LOL_EN	R/W	0b	Interrupt Enable Control for Loss-of-Lock Interrupt Status Bit: 0 = LOL_INT register bit will not affect status of nINT output signal 1 = LOL_INT register bit will affect status of nINT output signal
HOLD_EN	R/W	0b	Interrupt Enable Control for Holdover Interrupt Status Bit: 0 = HOLD_INT register bit will not affect status of nINT output signal 1 = HOLD_INT register bit will affect status of nINT output signal
LOSm_EN	R/W	0b	Interrupt Enable Control for Loss-of-Signal Interrupt Status Bit for Input Reference m: 0 = LOSm_INT register bit will not affect status of nINT output signal 1 = LOSm_INT register bit will affect status of nINT output signal
Rsvd	R/W	-	Reserved. Always write 0 to this bit location. Read values are not defined.

Table 21. Interrupt Status Register Bit Field Locations and Descriptions

This register contains “sticky” bits for tracking the status of the various alarms. Whenever an alarm occurs, the appropriate Interrupt Status bit will be set. The Interrupt Status bit will remain asserted even after the original alarm goes away. The Interrupt Status bits remain asserted until explicitly cleared by a write of a 1 to the bit over the serial port. This type of functionality is referred to as Read / Write-1-to-Clear (R/W1C).

Interrupt Status Register Block Field Locations								
Address (Hex)	D7	D6	D5	D4	D3	D2	D1	D0
0200	Rsvd	LOL_INT	Rsvd	HOLD_INT	Rsvd		LOS1_INT	LOS0_INT
0201	Rsvd							

Interrupt Status Register Block Field Descriptions			
Bit Field Name	Field Type	Default Value	Description
LOL_INT	R/W1C	0b	Interrupt Status Bit for Loss-of-Lock: 0 = No Loss-of-Lock alarm flag on PLL has occurred since the last time this register bit was cleared 1 = At least one Loss-of-Lock alarm flag on PLL has occurred since the last time this register bit was cleared
HOLD_INT	R/W1C	0b	Interrupt Status Bit for Holdover: 0 = No Holdover alarm flag has occurred since the last time this register bit was cleared 1 = At least one Holdover alarm flag has occurred since the last time this register bit was cleared
LOS _m _INT	R/W1C	0b	Interrupt Status Bit for Loss-of-Signal on Input Reference m: 0 = No Loss-of-Signal alarm flag on Input Reference m has occurred since the last time this register bit was cleared 1 = At least one Loss-of-Signal alarm flag on Input Reference m has occurred since the last time this register bit was cleared
Rsvd	R/W	-	Reserved. Always write 0 to this bit location. Read values are not defined.

Table 22. Digital PLL Status Register Bit Field Locations and Descriptions

The following register is included for debug purposes only. It shows the actual digital PLL0 state directly. This means that the bits may change rapidly as the DPLL operates. The fields in this register do not represent a “snapshot” in time, so they may be inconsistent with one another if the DPLL is rapidly changing at the time of reading. Fast changes in the status of the PLL cannot be captured by polling these bits, in which case, IDT recommends using the Sticky Bits interrupts and GPIOs.

Digital PLL Status Register Block Field Locations								
Address (Hex)	D7	D6	D5	D4	D3	D2	D1	D0
0202	Rsvd			Rsvd	NO_REF	CURR_REF[2:0]		
0203	Rsvd			PLLLCK	Rsvd	Rsvd	SM_STS[1:0]	
0204	Rsvd							Rsvd
0205	Rsvd							
0206	Rsvd							
0207	Rsvd							Rsvd
0208	Rsvd							
0209	Rsvd							
020A	Rsvd		Rsvd					
020B	Rsvd							

Digital PLL Status Register Block Field Descriptions			
Bit Field Name	Field Type	Default Value	Description
NO_REF	R/O	-	Valid Reference Status for Digital PLL: 0 = At least one valid Input Reference is present 1 = No valid Input References present
CURR_REF[2:0]	R/O	-	Currently Selected Reference Status for Digital PLL: 000 - 011 = No reference currently selected 100 = Input Reference 0 (CLK0, nCLK0) selected 101 = Input Reference 1 (CLK1, nCLK1) selected 110 = Reserved 111 = Reserved
PLLLCK	R/O	-	Digital PLL phase error value is less than lock criteria. Not asserted if PLL in Synthesizer Mode.
SM_STS[1:0]	R/O	-	Current State of Digital PLL: 00 = Reserved 01 = Freerun 10 = Normal 11 = Holdover
Rsvd	R/W	-	Reserved. Always write 0 to this bit location. Read values are not defined.

Table 23. General Purpose Input Status Register Bit Field Locations and Descriptions

Global Interrupt Status Register Block Field Locations								
Address (Hex)	D7	D6	D5	D4	D3	D2	D1	D0
020C	Rsvd				GPI[3]	GPI[2]	GPI[1]	GPI[0]

General Purpose Input Status Register Block Field Descriptions			
Bit Field Name	Field Type	Default Value	Description
GPI[3:0]	R/O	-	Shows current values on GPIO[3:0] pins that are configured as General-Purpose Inputs.
Rsvd	R/W	-	Reserved. Always write 0 to this bit location. Read values are not defined.

Table 24. Global Interrupt Status Register Bit Field Locations and Descriptions

Global Interrupt Status Register Block Field Locations								
Address (Hex)	D7	D6	D5	D4	D3	D2	D1	D0
020D	Rsvd		Rsvd		Rsvd			INT
020E	Rsvd				Rsvd			
020F	Rsvd			Rsvd				
0210	Rsvd					Rsvd	EEP_ERR	BOOTFAIL
0211	Rsvd	Rsvd	Rsvd	Rsvd	Rsvd	Rsvd	Rsvd	EEPDONE
0212	Rsvd							

Global Interrupt Status Register Block Field Descriptions			
Bit Field Name	Field Type	Default Value	Description
INT	R/O	-	Device Interrupt Status: 0 = No Interrupt Status bits that are enabled are asserted (nINT pin released) 1 = At least one Interrupt Status bit that is enabled is asserted (nINT pin asserted low)
EEP_ERR	R/O	-	CRC Mismatch on EEPROM Read. Once set this bit is only cleared by reset.
BOOTFAIL	R/O	-	Reading of Serial EEPROM failed. Once set this bit is only cleared by reset.
EEPDONE	R/O	-	Serial EEPROM Read cycle has completed. Once set this bit is only cleared by reset.
Rsvd	R/W	-	Reserved. Always write 0 to this bit location. Read values are not defined.

Absolute Maximum Ratings

Note: Stresses beyond those listed under *Absolute Maximum Ratings* may cause permanent damage to the device. These ratings are stress specifications only. Functional operation of product at these conditions or any conditions beyond those listed in the [DC Electrical Characteristics](#) or [AC Electrical Characteristics](#) is not implied. Exposure to absolute maximum rating conditions for extended periods may affect product reliability.

Table 25. Absolute Maximum Ratings Table

Item	Rating
Supply Voltage, V_{CC}	3.63V
Inputs, V_I OSC ^[a] Other Input	0V to 2V -0.5V to $V_{CC} + 0.5V$
Outputs, V_O (Q[3:0], nQ[3:0])	-0.5V to $V_{CCOX}^{[b]} + 0.5V$
Outputs, V_O (GPIO[3:0], SCLK, SDATA, nINT)	-0.5V to $V_{CCCS} + 0.5V$
Outputs, I_O (Q[3:0], nQ[3:0]) Continuous Current Surge Current	40mA 65mA
Outputs, I_O (GPIO[3:0], SCLK, SDATA, nINT) Continuous Current Surge Current	8mA 13mA
Junction Temperature, T_J	125°C
Storage Temperature, T_{STG}	-65°C to 150°C

[a] This limit only applies when over-driving the OSC_I input from an external clock source. When used with a crystal, this limit does not apply.

[b] V_{CCOX} denotes: V_{CCO0} , V_{CCO1} , V_{CCO2} , V_{CCO3} .

Supply Voltage Characteristics

Table 26. Power Supply DC Characteristics, $V_{CC} = 3.3V \pm 5\%$, $V_{EE} = 0V$, $T_A = -40^\circ C$ to $85^\circ C$

Symbol	Parameter	Test Conditions	Minimum	Typical	Maximum	Units
V_{CC}	Core Supply Voltage		3.135	3.3	3.465	V
V_{CCA}	Analog Supply Voltage		3.135	3.3	V_{CC}	V
V_{CCCS}	Control and Status Supply Voltage ^[a]		1.71		V_{CC}	V
I_{CC}	Core Supply Current ^[b]			40	53	mA
I_{CCCS}	Control and Status Supply Current ^[b]			3	5	mA
I_{CCA}	Analog Supply Current ^[b]			140	186	mA
I_{EE}	Power Supply Current ^[c]	Q[0:3] Configured for LVPECL Logic Levels. Outputs Unloaded		345	438	mA

[a] GPIO [3:0], SDATA, SCLK, S_A1, S_A0, nINT, nRST pins are floating.

[b] I_{CC} , I_{CCCS} , and I_{CCA} are included in I_{EE} when Q[0:3] configured for LVPECL logic levels.

[c] Internal dynamic switching current at maximum f_{OUT} is included.

Table 27. Power Supply DC Characteristics, $V_{CC} = 2.5V \pm 5\%$, $V_{EE} = 0V$, $T_A = -40^\circ C$ to $85^\circ C$

Symbol	Parameter	Test Conditions	Minimum	Typical	Maximum	Units
V_{CC}	Core Supply Voltage		2.375	2.5	2.625	V
V_{CCA}	Analog Supply Voltage		2.375	2.5	V_{CC}	V
V_{CCCS}	Control and Status Supply Voltage ^[a]		1.71		V_{CC}	V
I_{CC}	Core Supply Current ^[b]			39	50	mA
I_{CCCS}	Control and Status Supply Current ^[b]			3	5	mA
I_{CCA}	Analog Supply Current ^[b]			135	179	mA
I_{EE}	Power Supply Current ^[c]	Q[0:3] Configured for LVPECL Logic Levels. Outputs Unloaded		328	415	mA

[a] GPIO [3:0], SDATA, SCLK, S_A1, S_A0, nINT, nRST pins are floating.

[b] I_{CC} , I_{CCCS} , and I_{CCA} are included in I_{EE} when Q[0:3] configured for LVPECL logic levels.

[c] Internal dynamic switching current at maximum f_{OUT} is included.

Table 28. Maximum Output Supply Current, $V_{CC} = V_{CCCS} = 3.3V \pm 5\%$ or $2.5V \pm 5\%$, $V_{EE} = 0V$, $T_A = -40^\circ C$ to $85^\circ C$

Symbol	Parameter	Test Conditions	$V_{CCOx}^{[a]} = 3.3V \pm 5\%$				$V_{CCOx}^{[a]} = 2.5V \pm 5\%$				$V_{CCOx}^{[a]} = 1.8V \pm 5\%$	Units
			LVPECL	LVDS	HCSL	LVC MOS	LVPECL	LVDS	HCSL	LVC MOS	LVC MOS	
$I_{CCO0}^{[b]}$	Q0, nQ0 Output Supply Current	Outputs Unloaded	50	60	50	N/A	44	52	44	N/A	N/A	mA
$I_{CCO1}^{[b]}$	Q1, nQ1 Output Supply Current	Outputs Unloaded	52	63	52	N/A	45	54	45	N/A	N/A	mA
$I_{CCO2}^{[b]}$	Q2, nQ2 Output Supply Current	Outputs Unloaded	52	61	52	N/A	45	54	45	N/A	N/A	mA
$I_{CCO3}^{[b]}$	Q3, nQ3 Output Supply Current	Outputs Unloaded	58	67	58	63	52	61	52	56	52	mA

[a] V_{CCOx} denotes V_{CCO0} , V_{CCO1} , V_{CCO2} , V_{CCO3} .

[b] Internal dynamic switching current at maximum f_{OUT} is included.

DC Electrical Characteristics

Table 29. LVCMOS/LVTTL DC Characteristics, $V_{CC} = 3.3V \pm 5\%$ or $2.5V \pm 5\%$, $V_{EE} = 0V$, $T_A = -40^\circ C$ to $85^\circ C$ ^[a]

Symbol	Parameter		Test Conditions	Minimum	Typical	Maximum	Units
V_{IH}	Input High Voltage	GPIO[3:0], SDATA, SCLK, nRST, S_A0, S_A1	$V_{CCCS} = 3.3V$	2.1		$V_{CCCS} + 0.3$	V
			$V_{CCCS} = 2.5V$	1.7		$V_{CCCS} + 0.3$	V
			$V_{CCCS} = 1.8V$	1.4		$V_{CCCS} + 0.3$	V
V_{IL}	Input Low Voltage	GPIO[3:0], SDATA, SCLK, nRST, S_A0, S_A1	$V_{CCCS} = 3.3V$	-0.3		0.8	V
			$V_{CCCS} = 2.5V$	-0.3		0.6	V
			$V_{CCCS} = 1.8V$	-0.3		0.4	V
I_{IH}	Input High Current	S_A0, S_A1	$V_{CCCS} = V_{IN} = 3.465V, 2.625V, 1.89V$			150	μA
		nRST, SDATA, SCLK	$V_{CCCS} = V_{IN} = 3.465V, 2.625V, 1.89V$			5	μA
		GPIO[3:0]	$V_{CCCS} = V_{IN} = 3.465V, 2.625V, 1.89V$			1	mA
I_{IL}	Input Low Current	S_A0, S_A1	$V_{CCCS} = 3.465V, 2.625V, 1.89V, V_{IN} = 0V$	-5			μA
		nRST, SDATA, SCLK	$V_{CCCS} = 3.465V, 2.625V, 1.89V, V_{IN} = 0V$	-150			μA
		GPIO[3:0]	$V_{CCCS} = 3.465V, 2.625V, 1.89V, V_{IN} = 0V$	-1			mA
V_{OH}	Output High Voltage	GPIO[3:0]	$V_{CCCS} = 3.3V \pm 5\%, I_{OH} = -2mA$	2.4			V
		SDATA, SCLK, nINT ^[b]	$V_{CCCS} = 1.8V \pm 5\%, I_{OH} = -5\mu A$				
		GPIO[3:0]	$V_{CCCS} = 2.5V \pm 5\%, I_{OH} = -1mA$	1.7			
		SDATA, SCLK, nINT ^[b]	$V_{CCCS} = 2.5V \pm 5\%, I_{OH} = -5\mu A$				
		GPIO[3:0]	$V_{CCCS} = 1.8V \pm 5\%, I_{OH} = -5\mu A$	$V_{CCCS} - 0.45V$			
		SDATA, SCLK, nINT ^[b]					
V_{OL}	Output Low Voltage	SDATA, SCLK, nINT, GPIO[3:0] ^b	$V_{CCCS} = 3.3V \pm 5\%, I_{OL} = 2mA$			0.4	V
			$V_{CCCS} = 2.5V \pm 5\%, I_{OL} = 1mA$			0.4	V
			$V_{CCCS} = 1.8V \pm 5\%, I_{OL} = 2mA$			0.45	V

[a] V_{IL} should not be less than -0.3V.

[b] Use of external pull-up resistors is recommended for the SDATA, SCLK, nINT pins.

Table 30: Differential Input DC Characteristics, $V_{CC} = 3.3V \pm 5\%$ or $2.5V \pm 5\%$, $V_{EE} = 0V$, $T_A = -40^\circ C$ to $85^\circ C$

Symbol	Parameter ^[a]		Test Conditions	Minimum	Typical	Maximum	Units
I_{IH}	Input High Current	CLKx, nCLKx	$V_{CC} = V_{IN} = 3.465V$ or $2.625V$			150	μA
I_{IL}	Input Low Current	CLKx	$V_{CC} = 3.465V$ or $2.625V, V_{IN} = 0V$	-5			μA
		nCLKx	$V_{CC} = 3.465V$ or $2.625V, V_{IN} = 0V$	-150			μA
V_{PP}	Peak-to-Peak Voltage ^[b]			0.15		1.3	V
V_{CMR}	Common Mode Input Voltage ^{b, [c]}			V_{EE}		$V_{CC} - 1.2$	V

[a] CLKx denotes CLK0, CLK1. nCLKx denotes nCLK0, nCLK1

[b] V_{IL} should not be less than -0.3V. V_{IH} should not be higher than V_{CC} .

[c] Common mode voltage is defined as the cross-point.

Table 31. LVPECL DC Characteristics, $V_{CC} = 3.3V \pm 5\%$ or $2.5V \pm 5\%$, $V_{EE} = 0V$, $T_A = -40^\circ C$ to $85^\circ C$

Symbol	Parameter	Test Conditions	$V_{CC0x}^{[a]} = 3.3V \pm 5\%$			$V_{CC0x}^a = 2.5V \pm 5\%$			Units
			Minimum	Typical	Maximum	Minimum	Typical	Maximum	
V_{OH}	Output High Voltage ^[b]		$V_{CC0x} - 1.3$		$V_{CC0x} - 0.8$	$V_{CC0x} - 1.4$		$V_{CC0x} - 0.9$	V
V_{OL}	Output Low Voltage ^b		$V_{CC0x} - 1.95$		$V_{CC0x} - 1.75$	$V_{CC0x} - 1.95$		$V_{CC0x} - 1.75$	V

[a] V_{CC0x} denotes V_{CC00} , V_{CC01} , V_{CC02} , V_{CC03} .

[b] Outputs terminated with 50Ω to $V_{CC0x} - 2V$.

Table 32. LVDS DC Characteristics, $V_{CC} = 3.3V \pm 5\%$ or $2.5V \pm 5\%$, $V_{CC0x}^{[a]} = 3.3V \pm 5\%$ or $2.5V \pm 5\%$, $V_{EE} = 0V$, $T_A = -40^\circ C$ to $85^\circ C$ ^[b]

Symbol	Parameter	Test Conditions	Minimum	Typical	Maximum	Units
V_{OD}	Differential Output Voltage ^{[c],[d]}		250		450	mV
ΔV_{OD}	V_{OD} Magnitude Change				50	mV
V_{OS}	Offset Voltage		1.1		1.375	V
ΔV_{OS}	V_{OS} Magnitude Change				50	mV

[a] V_{CC0x} denotes V_{CC00} , V_{CC01} , V_{CC02} , and V_{CC03} .

[b] Terminated with 100Ω across Q_x and nQ_x .

[c] V_{OD} (Differential Output Voltage) refers to a single-ended value (swing of negative or positive signal only), not a differential value. Differential values can be obtained by doubling the single-ended measurement shown in this table.

[d] V_{OD} specification also applies to output frequencies $\leq 125MHz$.

Table 33. LVCMOS DC Characteristics (Q3 Only), $V_{CC} = 3.3V \pm 5\%$ or $2.5V \pm 5\%$, $V_{EE} = 0V$, $T_A = -40^\circ C$ to $85^\circ C$

Symbol	Parameter	Test Conditions	$V_{CC03} = 3.3V \pm 5\%$			$V_{CC03} = 2.5V \pm 5\%$			$V_{CC03} = 1.8V \pm 5\%$			Units
			Min.	Typ.	Max.	Min.	Typ.	Max.	Min.	Typ.	Max.	
V_{OH}	Output High Voltage	$I_{OH} = -8mA$	2.8			2.0			1.2			V
V_{OL}	Output Low Voltage	$I_{OL} = 8mA$			0.3			0.4			0.5	V

Table 34. Input Frequency Characteristics, $V_{CC} = 3.3V \pm 5\%$ or $2.5V \pm 5\%$, $T_A = -40^\circ C$ to $85^\circ C$

Symbol	Parameter		Test Conditions	Minimum	Typical	Maximum	Units
f_{IN}	Input Frequency ^[a]	OSCI, OSCO	Using a crystal (See Table 35 for Crystal Characteristics)	10		54	MHz
			Over-driving Crystal Input Doubler Logic Enabled ^[b]	10		54	MHz
			Over-driving Crystal Input Doubler Logic Disabled ^[b]	10		108	MHz
		CLKx, nCLKx ^[c]		0.008		875	MHz
f_{PD}	Phase Detector Frequency ^[d]			0.008		8	MHz
f_{SCLK}	Serial Port Clock SCLK (slave mode)	I ² C Operation		100		400	kHz

[a] For the input reference frequency, the divider values must be set for the VCO to operate within its supported range.

[b] For optimal noise performance, the use of a quartz crystal is recommended (for more information, see [Overdriving the XTAL Interface](#)).

[c] CLKx denotes CLK0, CLK1; nCLKx denotes nCLK0, nCLK1.

[d] Pre-dividers must be used to divide the CLKx frequency down to an f_{PD} valid frequency range.

Table 35. Crystal Characteristics

Parameter	Test Conditions	Minimum	Typical	Maximum	Units
Mode of Oscillation		Fundamental			
Frequency		10		54	MHz
Equivalent Series Resistance (ESR)			15	30	Ω
Load Capacitance (C_L)	Crystal frequency ≤ 40 MHz		12		pF
	Crystal frequency > 40 MHz			12	pF
Frequency Stability (total)		-100		100	ppm

AC Electrical Characteristics

Table 36. AC Characteristics, $V_{CC} = 3.3V \pm 5\%$ or $2.5V \pm 5\%$, $V_{CCOx} = 3.3V \pm 5\%$, $2.5V \pm 5\%$ or $1.8V \pm 5\%$ (1.8V Only Supported for LVCMOS Outputs), $T_A = -40^\circ C$ to $85^\circ C$ [a], [b]

Symbol	Parameter		Test Conditions	Min.	Typ.	Max.	Units	
f_{VCO}	VCO Operating Frequency			2440		2600	MHz	
f_{OUT}	Output Frequency	LVPECL, LVDS, HCSL	Q0, Q1, Q2 Outputs	15.25		866.67	MHz	
			Q3 Output integer divide	0.008		433.33	MHz	
			Q3 Output non-integer divide	0.008		325		
		LVCMOS	0.008		250	MHz		
t_R / t_F	Output Rise and Fall Times	LVPECL	20% to 80%		320	500	ps	
		LVDS	20% to 80%, $V_{CCOx} = 3.3V$		200	280	ps	
			20% to 80%, $V_{CCOx} = 2.5V$		200	400	ps	
		HCSL	20% to 80%		270	470	ps	
		LVCMOS ^[c] [d]	20% to 80%, $V_{CCOx} = 3.3V$		200	310	ps	
			20% to 80%, $V_{CCOx} = 2.5V$		240	360	ps	
20% to 80%, $V_{CCOx} = 1.8V$			350	550	ps			
SR	Output Slew Rate	LVPECL	Differential Waveform, Measured $\pm 150mV$ from Center	2		5.5	V/ns	
		LVDS	Differential Waveform, Measured $\pm 150mV$ from Center	$V_{CCOx} = 2.5V$	1		4	V/ns
				$V_{CCOx} = 3.3V$	1.5		5	V/ns
		HCSL	Measured on Differential Waveform, $\pm 150mV$ from Center, $V_{CCOx} = 2.5V$	2		4.8	V/ns	
			Measured on Differential Waveform, $\pm 150mV$ from Center, $V_{CCOx} = 3.3V$	3		7	V/ns	
$t_{sk(b)}$	Bank Skew ^{[e], [f], [g], [h]}	LVPECL Q[0:2], nQ[0:2]				50	ps	
		LVDS Q[0:2], nQ[0:2]				50	ps	
		HCSL Q[0:2], nQ[0:2]					50	ps
odc	Output Duty Cycle ^[i]	LVPECL, LVDS, HCSL		45	50	55	%	
		LVCMOS		40	50	60	%	
ΔSPO	Static Phase Offset Variation		$f_{IN}=f_{OUT}=156.25 MHz^{[j]}$	-250		250	ps	
	Initial Frequency Offset ^{[k], [l], [m]}		Switchover or Entering / Leaving Holdover State	-50		50	ppb	
	Output Phase Change in Fully Hitless Switching ^[n]		Switchover or Entering / Leaving Holdover State		2		ns	

Table 36. AC Characteristics, $V_{CC} = 3.3V \pm 5\%$ or $2.5V \pm 5\%$, $V_{CCOx} = 3.3V \pm 5\%$, $2.5V \pm 5\%$ or $1.8V \pm 5\%$ (1.8V Only Supported for LVCMOS Outputs), $T_A = -40^\circ C$ to $85^\circ C$ [a], [b] (Cont.)

Symbol	Parameter	Test Conditions	Min.	Typ.	Max.	Units
$\Phi_{SSB}(1)$	Single Sideband Phase Noise ^[o]	122.88MHz Output Jitter Attenuator Mode Input Frequency: 25MHz, XTAL Frequency: 40.8MHz		-51		dBc/Hz
$\Phi_{SSB}(10)$				-67		dBc/Hz
$\Phi_{SSB}(100)$				-69		dBc/Hz
$\Phi_{SSB}(1k)$				-107		dBc/Hz
$\Phi_{SSB}(10k)$				-128		dBc/Hz
$\Phi_{SSB}(100k)$				-136		dBc/Hz
$\Phi_{SSB}(1M)$				-155		dBc/Hz
$\Phi_{SSB}(10M)$				-161		dBc/Hz
$\Phi_{SSB}(30M)$				-162		dBc/Hz
$\Phi_{SSB}(1)$	Single Sideband Phase Noise ^[p]	156.25MHz Output Jitter Attenuator Mode Input Frequency: 25MHz XTAL Frequency: 49.152MHz		-45		dBc/Hz
$\Phi_{SSB}(10)$				-64		dBc/Hz
$\Phi_{SSB}(100)$				-74		dBc/Hz
$\Phi_{SSB}(1k)$				-105		dBc/Hz
$\Phi_{SSB}(10k)$				-129		dBc/Hz
$\Phi_{SSB}(100k)$				-134		dBc/Hz
$\Phi_{SSB}(1M)$				-152		dBc/Hz
$\Phi_{SSB}(10M)$				-159		dBc/Hz
$\Phi_{SSB}(30M)$				-160		dBc/Hz
$\Phi_{SSB}(1)$	Single Sideband Phase Noise ^[q]	161.1328125MHz Output Fractional Feedback Synthesizer Mode XTAL Frequency: 49.152MHz		-25		dBc/Hz
$\Phi_{SSB}(10)$				-61		dBc/Hz
$\Phi_{SSB}(100)$				-95		dBc/Hz
$\Phi_{SSB}(1k)$				-122		dBc/Hz
$\Phi_{SSB}(10k)$				-127		dBc/Hz
$\Phi_{SSB}(100k)$				-135		dBc/Hz
$\Phi_{SSB}(1M)$				-152		dBc/Hz
$\Phi_{SSB}(10M)$				-155		dBc/Hz
$\Phi_{SSB}(30M)$				-159		dBc/Hz
	Spurious Limit at Offset ^[r]	$\geq 800kHz$		-85		dBc

Table 36. AC Characteristics, $V_{CC} = 3.3V \pm 5\%$ or $2.5V \pm 5\%$, $V_{CC0x} = 3.3V \pm 5\%$, $2.5V \pm 5\%$ or $1.8V \pm 5\%$ (1.8V Only Supported for LVCMOS Outputs), $T_A = -40^\circ C$ to $85^\circ C$ [a], [b] (Cont.)

Symbol	Parameter	Test Conditions	Min.	Typ.	Max.	Units	
$t_{startup}$	Startup Time	Internal OTP Startup ^[1]	From $V_{CC} > 80\%$ to First Output Clock Edge		120	150	ms
		External EEPROM Startup ^{[1, [s]]}	From $V_{CC} > 80\%$ to First Output Clock Edge (0 retries) at Minimum I ² C Frequency		150	200	ms
			From $V_{CC} > 80\%$ to First Output Clock Edge (0 retries) at Maximum I ² C Frequency		130	150	ms
			From $V_{CC} > 80\%$ to First Output Clock Edge (32 retries) at Minimum I ² C Frequency		820	1200	ms
			From $V_{CC} > 80\%$ to First Output Clock Edge (32 retries) at Maximum I ² C Frequency		350	500	ms

[a] V_{CC0x} denotes V_{CC00} , V_{CC01} , V_{CC02} , V_{CC03} .

[b] Electrical parameters are guaranteed over the specified ambient operating temperature range, which is established when the device is mounted in a test socket with maintained transverse airflow greater than 500lfpm. The device will meet specifications after thermal equilibrium has been reached under these conditions.

[c] Appropriate SE_MODE bit must be configured to select phase-aligned or phase-inverted operation.

[d] All Q and nQ outputs in phase-inverted operation.

[e] This parameter is guaranteed by characterization. Not tested in production.

[f] This parameter is defined in accordance with JEDEC Standard 65.

[g] Measured at the output differential cross point.

[h] Defined as skew within a bank of outputs at the same supply voltage and with equal load conditions.

[i] Characterized in PLL Mode. Duty cycle of bypassed signals (input reference clocks or crystal input) is not adjusted by the device.

[j] This parameter was measured using CLK0 as the reference input and CLK1 as the external feedback input. Characterized with 8T49N240-906NLGI.

[k] Tested in fast-lock operation after >20 minutes of locked operation to ensure holdover averaging logic is stable.

[l] This parameter is guaranteed by design.

[m] Using internal feedback mode configuration.

[n] Device programmed with SWMODE = 0 (absorbs phase differences).

[o] Characterized with 8T49N240-900.

[p] Characterized with 8T49N240-901.

[q] Characterized with 8T49N240-902.

[r] Tested with all outputs operating at 156.25MHz.

[s] Assuming a clear I²C bus.

Table 37. HCSL AC Characteristics, $V_{CC} = 3.3V \pm 5\%$ or $2.5V \pm 5\%$, $V_{CCOx} = 3.3V \pm 5\%$ or $2.5V \pm 5\%$, $T_A = -40^\circ C$ to $85^\circ C$ ^{[a], [b]}

Symbol	Parameter	Test Conditions	Minimum	Typical	Maximum	Units
V_{RB}	Ring-back Voltage Margin ^{[c], [d]}		-100		100	mV
t_{STABLE}	Time before V_{RB} is allowed ^{c, d}		500			ps
V_{MAX}	Absolute Max. Output Voltage ^{[e], [f]}				1150	mV
V_{MIN}	Absolute Min. Output Voltage ^{e, [g]}		-300			mV
V_{CROSS}	Absolute Crossing Voltage ^{[h], [i]}		200		500	mV
ΔV_{CROSS}	Total Variation of V_{CROSS} Over all Edges ^{h, [j]}				140	mV

[a] Electrical parameters are guaranteed over the specified ambient operating temperature range, which is established when the device is mounted in a test socket with maintained transverse airflow greater than 500 lfm. The device will meet specifications after thermal equilibrium has been reached under these conditions.

[b] V_{CCOx} denotes V_{CCO0} , V_{CCO1} , V_{CCO2} , V_{CCO3} .

[c] Measurement taken from differential waveform.

[d] t_{STABLE} is the time the differential clock must maintain a minimum $\pm 150mV$ differential voltage after rising/falling edges before it is allowed to drop back into the $V_{RB} \pm 100mV$ differential range.

[e] Measurement taken from single ended waveform.

[f] Defined as the maximum instantaneous voltage including overshoot.

[g] Defined as the minimum instantaneous voltage including undershoot.

[h] Measured at crossing point where the instantaneous voltage value of the rising edge of Qx equals the falling edge of nQx .

[i] Refers to the total variation from the lowest crossing point to the highest, regardless of which edge is crossing. Refers to all crossing points for this measurement.

[j] Defined as the total variation of all crossing voltages of rising Qx and falling nQx , This is the maximum allowed variance in V_{CROSS} for any particular system.

Table 38. RMS Phase Jitter, $V_{CC} = 3.3V \pm 5\%$, $V_{CC0x} = 3.3V \pm 5\%$, $2.5V \pm 5\%$ or $1.8V \pm 5\%$ (1.8V Only Supported for LVCMOS Outputs), $T_A = -40^\circ C$ to $85^\circ C$ ^[a] ^[b]

Symbol	Parameter		Test Conditions	Typical	Maximum	Units
tjit(ϕ)	Typical RMS Phase Jitter (Random)	Q0, Q1, Q2	f _{OUT} = 122.88MHz, Integration Range 12kHz - 20MHz Jitter Attenuator Mode (40.8MHz Crystal) ^[c]	199	233	fs
			f _{OUT} = 156.25MHz, Integration Range 12kHz - 20MHz; Jitter Attenuator Mode (49.152MHz Crystal) ^[d]	185	236	fs
			f _{OUT} = 161.1328125MHz, Integration Range 12kHz - 20MHz; Synthesizer Mode (49.152MHz Crystal) ^[e]	184	237	fs
		Q3 Integer Output Divider	f _{OUT} = 122.88MHz, Integration Range 12kHz - 20MHz; Jitter Attenuator Mode (40.8MHz Crystal) ^[c]	249	308	fs
			f _{OUT} = 156.25MHz, Integration Range 12kHz - 20MHz; Jitter Attenuator Mode (49.152MHz Crystal) ^[d]	229	270	fs
			f _{OUT} = 161.1328125MHz, Integration Range 12kHz - 20MHz; Synthesizer Mode (49.152MHz Crystal) ^[e]	227	268	fs
		Q3 Fractional Output Divider	f _{OUT} = 122.88MHz, Integration Range 12kHz - 20MHz; Jitter Attenuator Mode (40.8MHz Crystal) ^[f]	239	279	fs
			f _{OUT} = 156.25MHz, Integration Range 12kHz - 20MHz; Jitter Attenuator Mode (49.152MHz Crystal) ^[g]	243	312	fs
			f _{OUT} = 161.1328125MHz, Integration Range 12kHz - 20MHz; Synthesizer Mode (49.152MHz Crystal) ^[h]	222	252	fs

[a] V_{CC0x} denotes V_{CC00} , V_{CC01} , V_{CC02} , and V_{CC03} .

[b] Tested with all outputs running at the specified output frequency. All outputs derived from PLL.

[c] Characterized with 8T49N240-900.

[d] Characterized with 8T49N240-901.

[e] Characterized with 8T49N240-902.

[f] Characterized with 8T49N240-903.

[g] Characterized with 8T49N240-904.

[h] Characterized with 8T49N240-905.

Table 39. RMS Phase Jitter, $V_{CC} = 2.5V \pm 5\%$, $V_{CC0x} = 3.3V \pm 5\%$, $2.5V \pm 5\%$ or $1.8V \pm 5\%$ (1.8V Only Supported for LVCMOS Outputs), $T_A = -40^\circ C$ to $85^\circ C$ ^[a] ^[b]

Symbol	Parameter		Test Conditions	Typical	Maximum	Units
t _{jit} (φ)	Typical RMS Phase Jitter (Random)	Q0, Q1, Q2	f _{OUT} = 122.88MHz, Integration Range 12kHz - 20MHz Jitter Attenuator Mode (40.8MHz Crystal) ^[c]	220	299	fs
			f _{OUT} = 156.25MHz, Integration Range 12kHz - 20MHz; Jitter Attenuator Mode (49.152MHz Crystal) ^[d]	192	266	fs
			f _{OUT} = 161.1328125MHz, Integration Range 12kHz - 20MHz; Synthesizer Mode (49.152MHz Crystal) ^[e]	205	299	fs
		Q3 Integer Output Divider	f _{OUT} = 122.88MHz, Integration Range 12kHz - 20MHz; Jitter Attenuator Mode (40.8MHz Crystal) ^[c]	277	359	fs
			f _{OUT} = 156.25MHz, Integration Range 12kHz - 20MHz; Jitter Attenuator Mode (49.152MHz Crystal) ^[d]	243	292	fs
			f _{OUT} = 161.1328125MHz, Integration Range 12kHz - 20MHz; Synthesizer Mode (49.152MHz Crystal) ^[e]	242	326	fs
		Q3 Fractional Output Divider	f _{OUT} = 122.88MHz, Integration Range 12kHz - 20MHz; Jitter Attenuator Mode (40.8MHz Crystal) ^[f]	247	287	fs
			f _{OUT} = 156.25MHz, Integration Range 12kHz - 20MHz; Jitter Attenuator Mode (49.152MHz Crystal) ^[g]	251	339	fs
			f _{OUT} = 161.1328125MHz, Integration Range 12kHz - 20MHz; Synthesizer Mode (49.152MHz Crystal) ^[h]	240	297	fs

[a] V_{CC0x} denotes V_{CC00} , V_{CC01} , V_{CC02} , and V_{CC03} .

[b] Tested with all outputs running at the specified output frequency. All outputs derived from PLL.

[c] Characterized with 8T49N240-900.

[d] Characterized with 8T49N240-901.

[e] Characterized with 8T49N240-902.

[f] Characterized with 8T49N240-903.

[g] Characterized with 8T49N240-904.

[h] Characterized with 8T49N240-905.

Table 40. PCI Express Jitter Specifications, $V_{CC} = V_{CC0x} = 3.3V \pm 5\%$ or $2.5V \pm 5\%$, $T_A = -40^\circ C$ to $85^\circ C$ ^{[a], [b]}

Symbol	Parameter	Test Conditions	Min.	Typ.	Max.	PCIe Industry Specification	Units
t_j (PCIe Gen 1)	Phase Jitter Peak-to-Peak ^{[c], [d]}	$f = 100MHz$, 25MHz Crystal Input Evaluation Band: 0Hz - Nyquist (clock frequency/2)		6.8	12	86	ps
$t_{REFCLK_HF_RMS}$ (PCIe Gen 2)	Phase Jitter RMS ^{d, [e]}	$f = 100MHz$, 25MHz Crystal Input High Band: 1.5MHz - Nyquist (clock frequency/2)		0.5	1.1	3.10	ps
$t_{REFCLK_LF_RMS}$ (PCIe Gen 2)	Phase Jitter RMS ^{d, [e]}	$f = 100MHz$, 25MHz Crystal Input Low Band: 10kHz - 1.5MHz		0.2	0.7	3.0	ps
t_{REFCLK_RMS} (PCIe Gen 3)	Phase Jitter RMS ^{d, [f]}	$f = 100MHz$, 25MHz Crystal Input Evaluation Band: 0Hz - Nyquist (clock frequency/2)		0.13	0.3	0.8	ps

[a] V_{CC0x} denotes V_{CC00} , V_{CC01} , V_{CC02} , V_{CC03} .

[b] Electrical parameters are guaranteed over the specified ambient operating temperature range, which is established when the device is mounted in a test socket with maintained transverse airflow greater than 500 lfpm. The device will meet specifications after thermal equilibrium has been reached under these conditions.

[c] Peak-to-Peak jitter after applying system transfer function for the Common Clock Architecture. Maximum limit for PCI Express Gen 1

[d] This parameter is guaranteed by characterization. Not tested in production.

[e] RMS jitter after applying the two evaluation bands to the two transfer functions defined in the Common Clock Architecture and reporting the worst case results for each evaluation band. Maximum limit for PCI Express Generation 2 is 3.1ps RMS for $t_{REFCLK_HF_RMS}$ (High Band) and 3.0ps RMS for $t_{REFCLK_LF_RMS}$ (Low Band).

[f] RMS jitter after applying system transfer function for the common clock architecture. This specification is based on the PCI Express Base Specification Revision 0.7, October 2009 and is subject to change pending the final release version of the specification.

Typical Phase Noise at 156.25MHz

Phase Noise 10.00dB/ Ref 0.000dBc/Hz

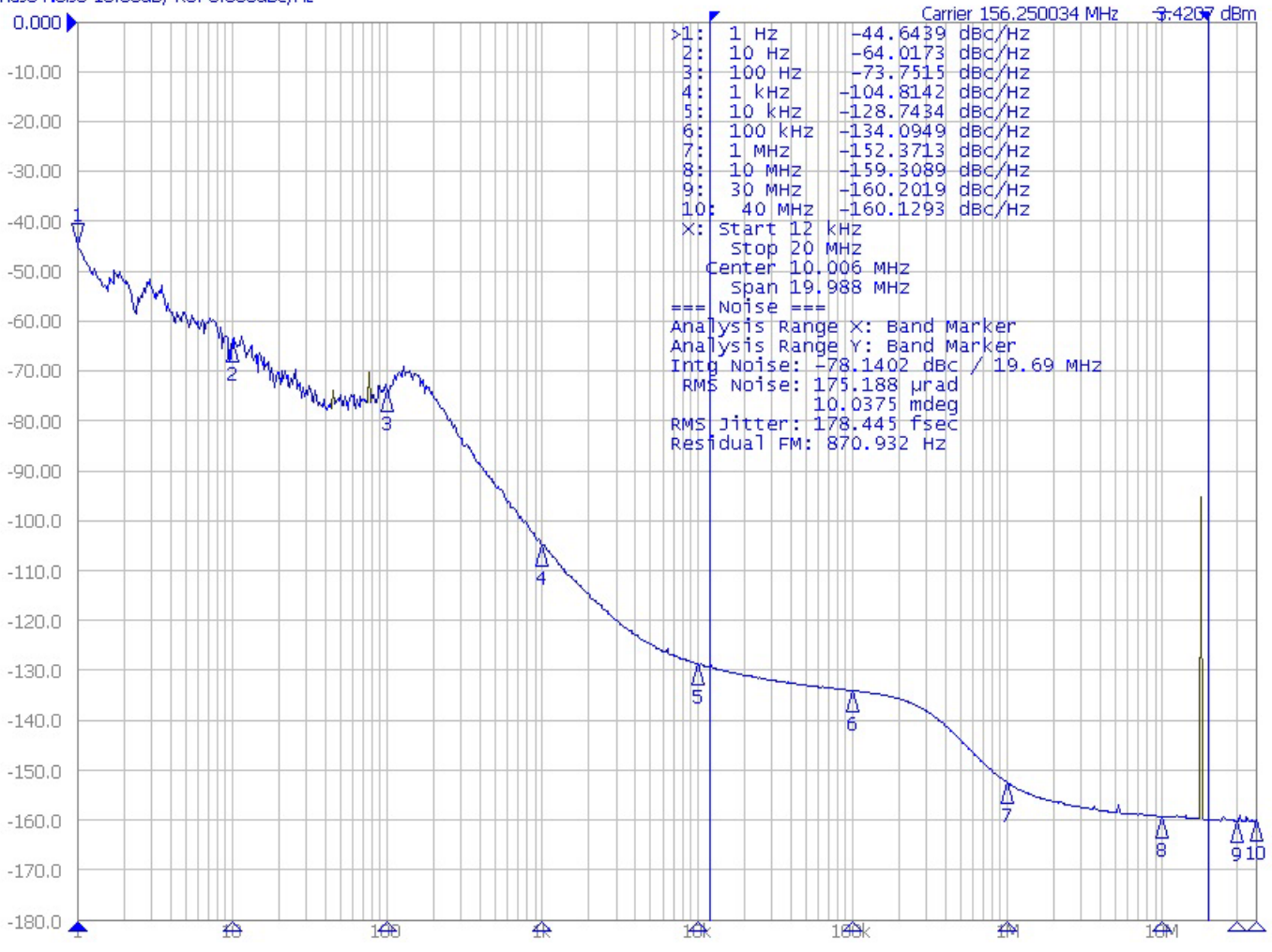

Applications Information

Recommendations for Unused Input and Output Pins

Inputs

CLKx/nCLKx Input

For applications not requiring the use of one or more reference clock inputs, both CLKx and nCLKx can be left floating. Though not required, but for additional protection, a 1k Ω resistor can be tied from CLKx to ground. It is recommended that CLKx, nCLKx not be driven with active signals when not selected.

LVC MOS Control Pins

All control pins have internal pullups or pulldowns; additional resistance is not required but can be added for additional protection. A 1k Ω resistor can be used.

Outputs

LVPECL Outputs

Any unused LVPECL output pair can be left floating. We recommend that there is no trace attached. Both sides of the differential output pair should either be left floating or terminated.

LVDS Outputs

Any unused LVDS output pair can be either left floating or terminated with 100 Ω across. If they are left floating there should be no trace attached.

LVC MOS Outputs

Any LVC MOS output can be left floating if unused. There should be no trace attached.

HCSL Outputs

All unused differential outputs can be left floating. We recommend that there is no trace attached. Both sides of the differential output pair should either be left floating or terminated.

Overdriving the XTAL Interface

The OSC1 input can be overdriven by an LVCMOS driver or by one side of a differential driver through an AC coupling capacitor. The OSC0 pin can be left floating. The amplitude of the input signal should be between 500mV and 1.8V and the slew rate should not be less than 0.2V/ns. For 3.3V LVCMOS inputs, the amplitude must be reduced from full swing to at least half the swing in order to prevent signal interference with the power rail and to reduce internal noise.

Figure 5 shows an example of the interface diagram for a high speed 3.3V LVCMOS driver. This configuration requires that the sum of the output impedance of the driver (R_o) and the series resistance (R_s) equals the transmission line impedance. In addition, matched termination at the crystal input will attenuate the signal in half. This can be done in one of two ways. First, R_1 and R_2 in parallel should equal the transmission line impedance. For most 50Ω applications, R_1 and R_2 can be 100Ω . This can also be accomplished by removing R_1 and changing R_2 to 50Ω . The values of the resistors can be increased to reduce the loading for a slower and weaker LVCMOS driver.

Figure 5. General Diagram for LVCMOS Driver to XTAL Input Interface

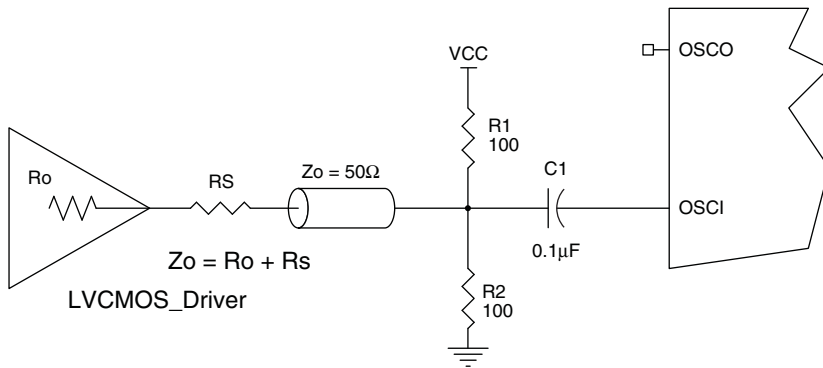
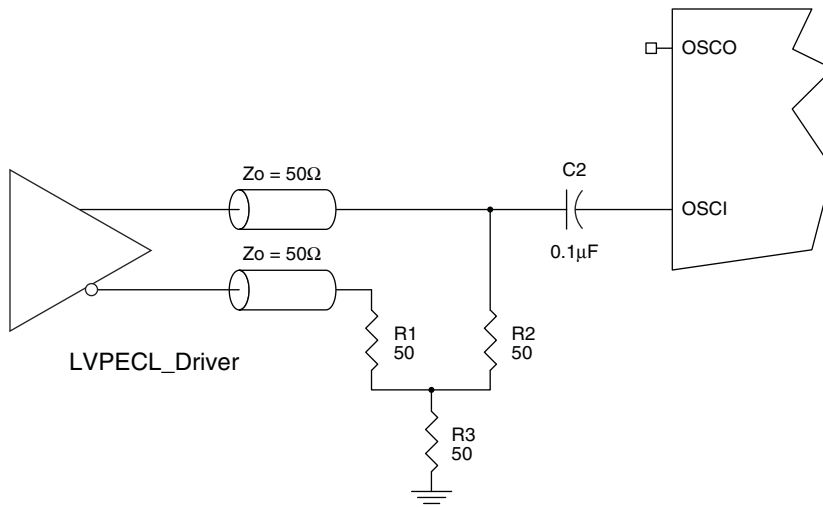

Figure 6 shows an example of the interface diagram for an LVPECL driver. This is a standard LVPECL termination with one side of the driver feeding the XTAL_IN input. It is recommended that all components in the schematics be placed in the layout. Though some components might not be used, they can be utilized for debugging purposes. The datasheet specifications are characterized and guaranteed by using a quartz crystal as the input.

Figure 6. General Diagram for LVPECL Driver to XTAL Input Interface



Wiring the Differential Input to Accept Single-Ended Levels

Figure 7 shows how a differential input can be wired to accept single ended levels. The reference voltage $V_{REF} = V_{CC}/2$ is generated by the bias resistors R1 and R2. The bypass capacitor (C1) is used to help filter noise on the DC bias. This bias circuit should be located as close to the input pin as possible. The ratio of R1 and R2 might need to be adjusted to position the V_{REF} in the center of the input voltage swing. For example, if the input clock swing is 2.5V and $V_{CC} = 3.3V$, R1 and R2 value should be adjusted to set V_{REF} at 1.25V. The values below are for when both the single ended swing and V_{CC} are at the same voltage. This configuration requires that the sum of the output impedance of the driver (R_o) and the series resistance (R_s) equals the transmission line impedance. In addition, matched termination at the input will attenuate the signal in half. This can be done in one of two ways.

First, R3 and R4 in parallel should equal the transmission line impedance. For most 50Ω applications, R3 and R4 can be 100Ω. The values of the resistors can be increased to reduce the loading for slower and weaker LVCMOS driver. When using single-ended signaling, the noise rejection benefits of differential signaling are reduced. Even though the differential input can handle full rail LVCMOS signaling, it is recommended that the amplitude be reduced. The datasheet specifies a lower differential amplitude, however this only applies to differential signals. For single-ended applications, the swing can be larger, however V_{IL} cannot be less than -0.3V and V_{IH} cannot be more than $V_{CC} + 0.3V$. Suggest edge rate faster than 1V/ns. Though some of the recommended components might not be used, the pads should be placed in the layout. They can be utilized for debugging purposes. The datasheet specifications are characterized and guaranteed by using a differential signal.

Figure 7. Recommended Schematic for Wiring a Differential Input to Accept Single-ended Levels

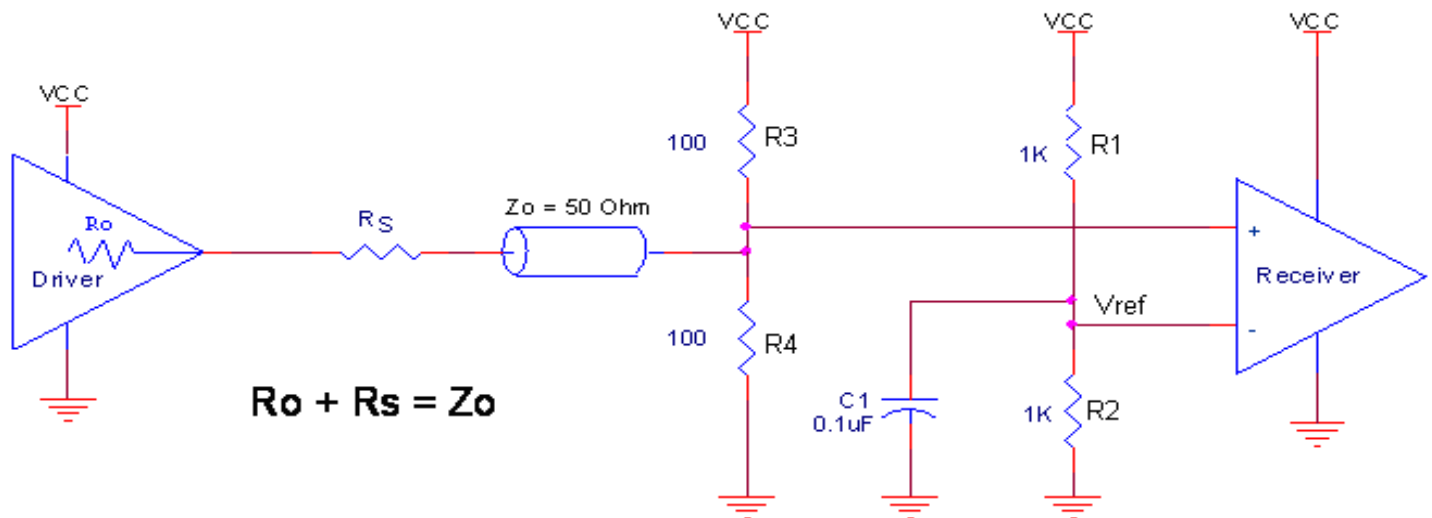

3.3V Differential Clock Input Interface

CLKx/nCLKx accepts LVDS, LVPECL, LVHSTL, HCSL and other differential signals. Both V_{SWING} and V_{OH} must meet the V_{PP} and V_{CMR} input requirements. Figure 8 to Figure 12 show interface examples for the CLKx/nCLKx input driven by the most common driver types. The input interfaces suggested here are examples only.

Please consult with the vendor of the driver component to confirm the driver termination requirements. For example, in Figure 8, the input termination applies for IDT open emitter LVHSTL drivers. If you are using an LVHSTL driver from another vendor, use their termination recommendation.

Figure 8. CLKx/nCLKx Input Driven by an IDT Open Emitter LVHSTL Driver

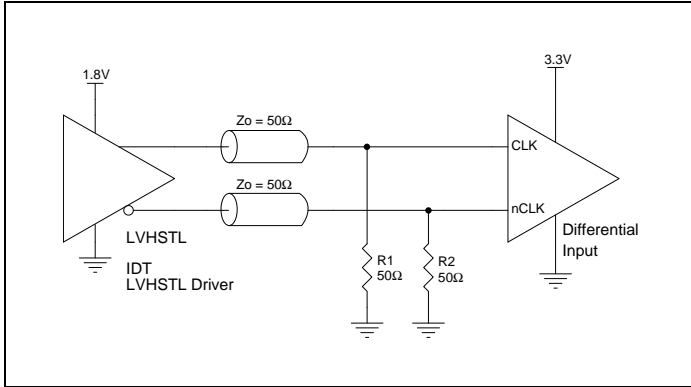

Figure 9. CLKx/nCLKx Input Driven by a 3.3V LVPECL Driver

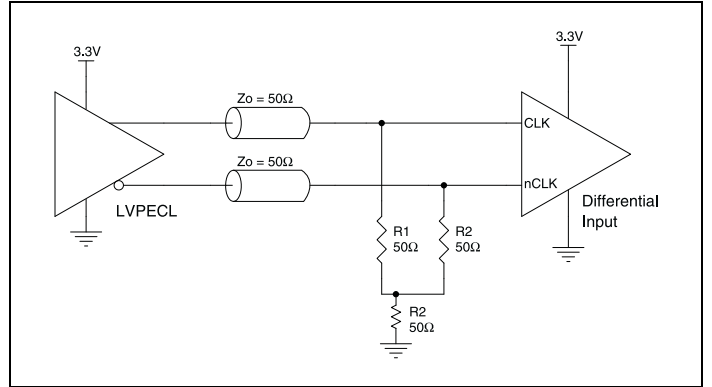

Figure 10. CLKx/nCLKx Input Driven by a 3.3V LVPECL Driver

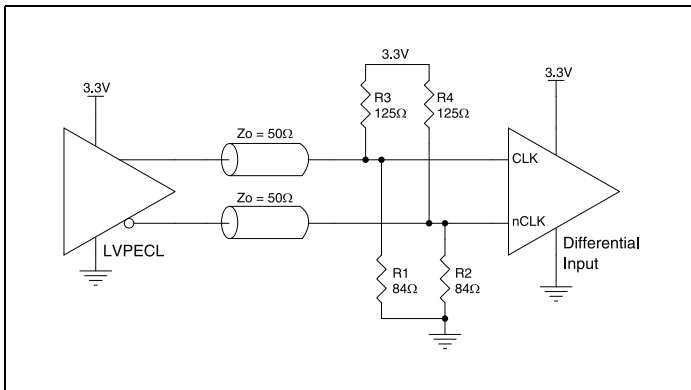

Figure 11. CLKx/nCLKx Input Driven by a 3.3V LVDS Driver

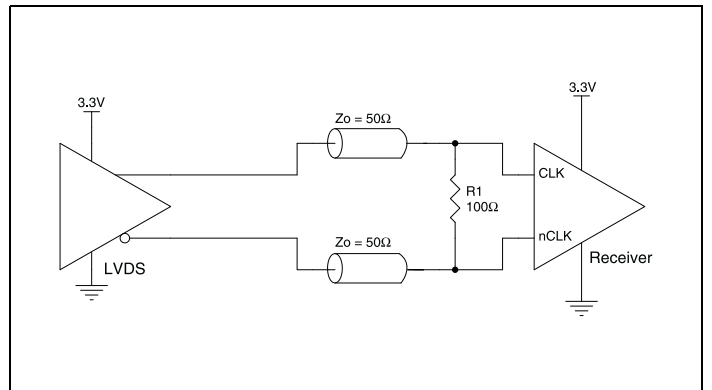
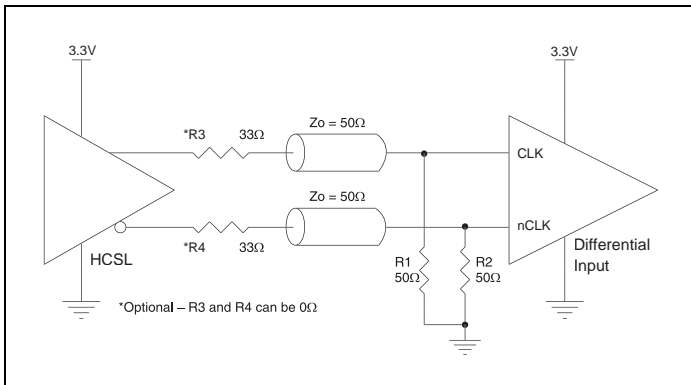

Figure 12. CLKx/nCLKx Input Driven by a 3.3V HCSL Driver



2.5V Differential Clock Input Interface

CLKx/nCLKx accepts LVDS, LVPECL, LVHSTL, HCSL and other differential signals. Both V_{SWING} and V_{OH} must meet the V_{PP} and V_{CMR} input requirements. Figure 13 to Figure 17 show interface examples for the CLKx/nCLKx input driven by the most common driver types.

The input interfaces suggested here are examples only. Please consult with the vendor of the driver component to confirm the driver termination requirements. For example, in Figure 13, the input termination applies for IDT open emitter LVHSTL drivers. If you are using an LVHSTL driver from another vendor, use their termination recommendation.

Figure 13. CLKx/nCLKx Input Driven by an IDT Open Emitter LVHSTL Driver

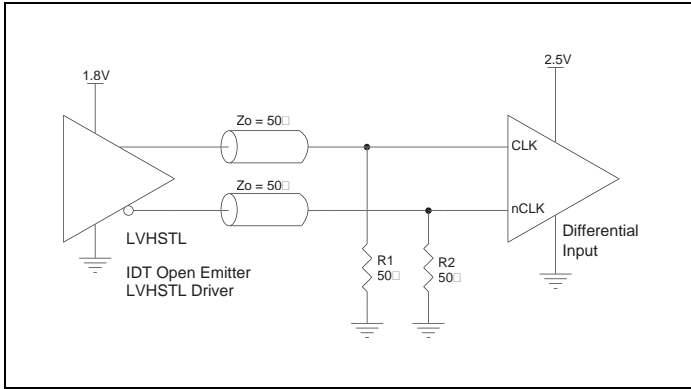

Figure 14. CLKx/nCLKx Input Driven by a 2.5V LVPECL Driver

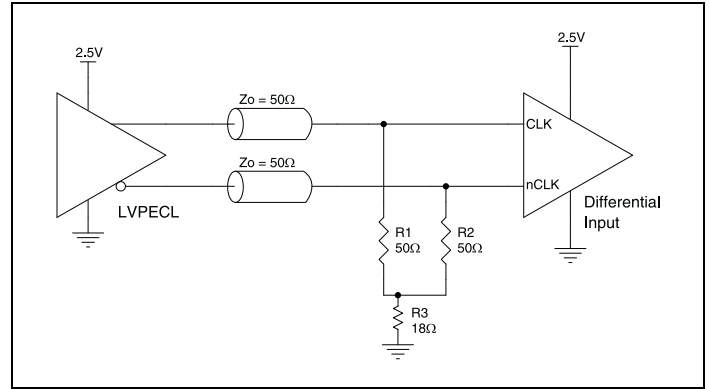

Figure 15. CLKx/nCLKx Input Driven by a 2.5V LVPECL Driver

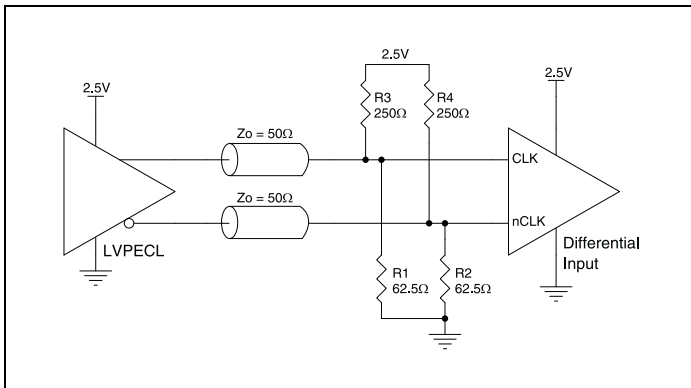

Figure 16. CLKx/nCLKx Input Driven by a 2.5V LVDS Driver

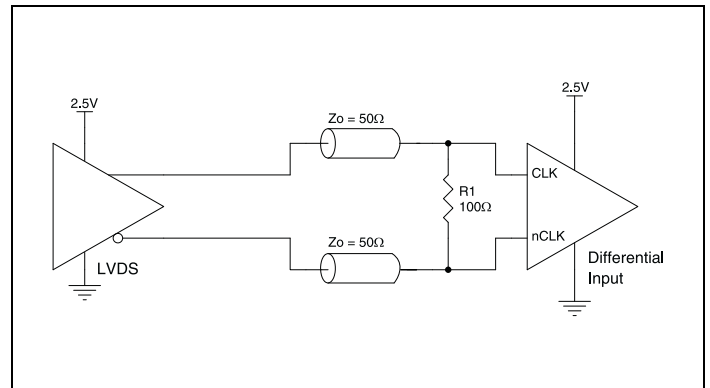
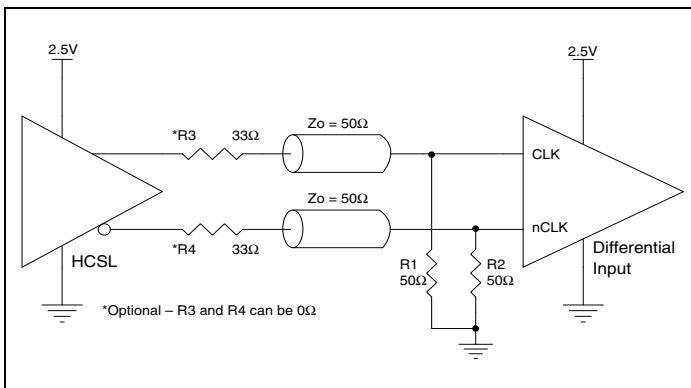

Figure 17. CLKx/nCLKx Input Driven by a 2.5V HCSL Driver



LVDS Driver Termination

For a general LVDS interface, the recommended value for the termination impedance (Z_T) is between 90Ω and 132Ω . The actual value should be selected to match the differential impedance (Z_0) of your transmission line. A typical point-to-point LVDS design uses a 100Ω parallel resistor at the receiver and a 100Ω differential transmission-line environment. In order to avoid any transmission-line reflection issues, the components should be surface mounted and must be placed as close to the receiver as possible. IDT offers a full line of LVDS compliant devices with two types of output structures: current source and voltage source.

The standard termination schematic as shown in Figure 18 can be used with either type of output structure. Figure 19, which can also be used with both output types, is an optional termination with center tap capacitance to help filter common mode noise. The capacitor value should be approximately 50pF . If using a non-standard termination, it is recommended to contact IDT and confirm if the output structure is current source or voltage source type. In addition, since these outputs are LVDS compatible, the input receiver's amplitude and common-mode input range should be verified for compatibility with the output.

Figure 18. Standard LVDS Termination

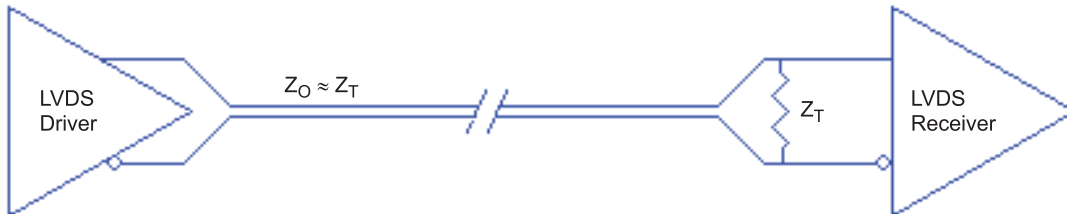
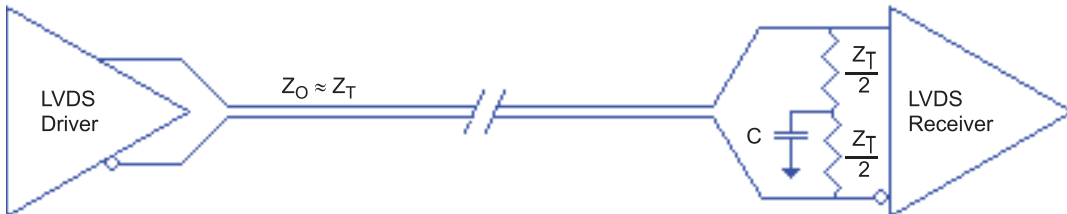

Figure 19. Optional LVDS Termination



Termination for 3.3V LVPECL Outputs

The clock layout topology shown below is a typical termination for LVPECL outputs. The two different layouts mentioned are recommended only as guidelines.

The differential outputs generate ECL/LVPECL compatible outputs. Therefore, terminating resistors (DC current path to ground) or current sources must be used for functionality. These outputs are designed to drive 50Ω transmission lines. Matched impedance techniques should be used to maximize operating frequency and minimize signal distortion. Figure 20 and Figure 21 show two different layouts which are recommended only as guidelines. Other suitable clock layouts may exist and it would be recommended that the board designers simulate to guarantee compatibility across all printed circuit and clock component process variations.

Figure 20. 3.3V LVPECL Output Termination

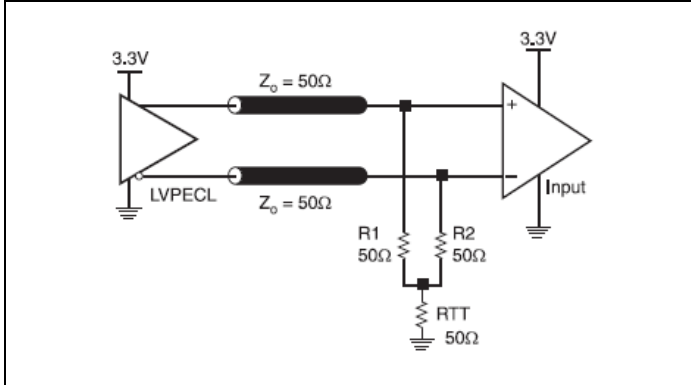
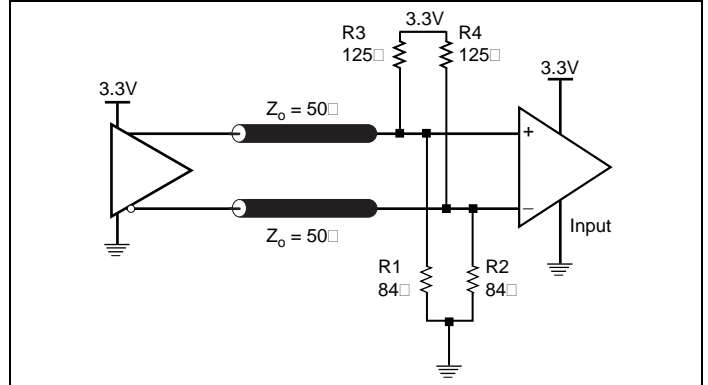

Figure 21. 3.3V LVPECL Output Termination



Termination for 2.5V LVPECL Outputs

Figure 22 to Figure 24 show examples of termination for 2.5V LVPECL driver. These terminations are equivalent to terminating 50Ω to $V_{CC0} - 2V$. For $V_{CC0} = 2.5V$, the $V_{CC0} - 2V$ is very close to ground level. The R3 in Figure 24 can be eliminated and the termination is shown in Figure 23.

Figure 22. 2.5V LVPECL Driver Termination Example

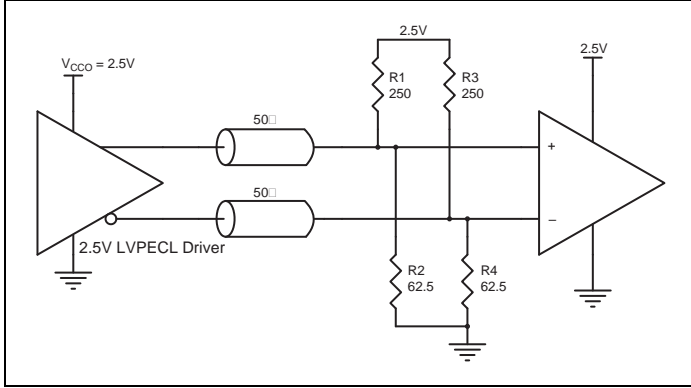

Figure 23. 2.5V LVPECL Driver Termination Example

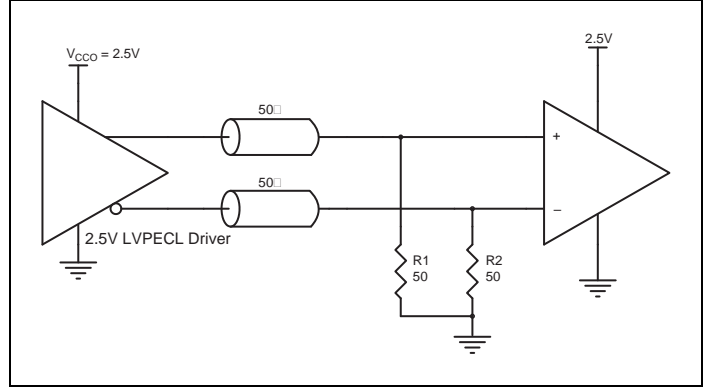
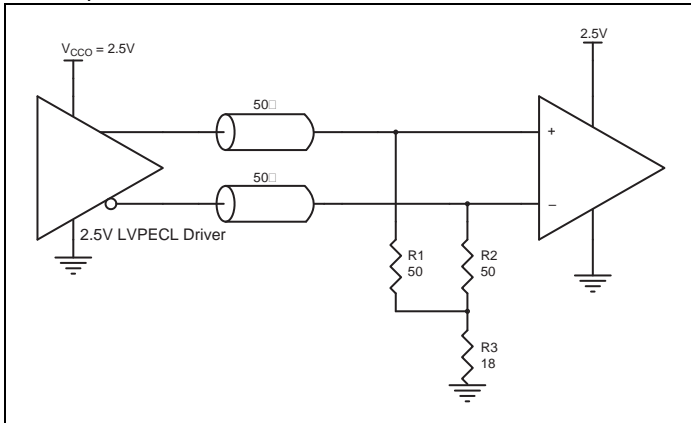

Figure 24. 2.5V LVPECL Driver Termination Example



HCSL Recommended Termination

Figure 25 is the recommended source termination for applications where the driver and receiver will be on a separate PCBs. This termination is the standard for PCI Express™ and HCSL output types. All traces should be 50Ω impedance single-ended or 100Ω differential.

Figure 25. Recommended Source Termination (Where the driver and receiver will be on separate PCBs)

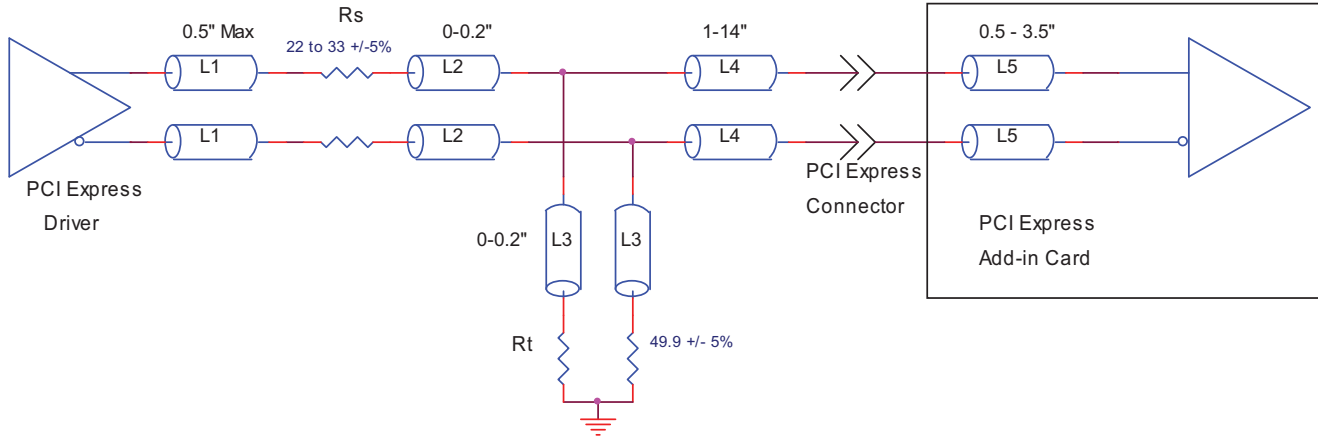
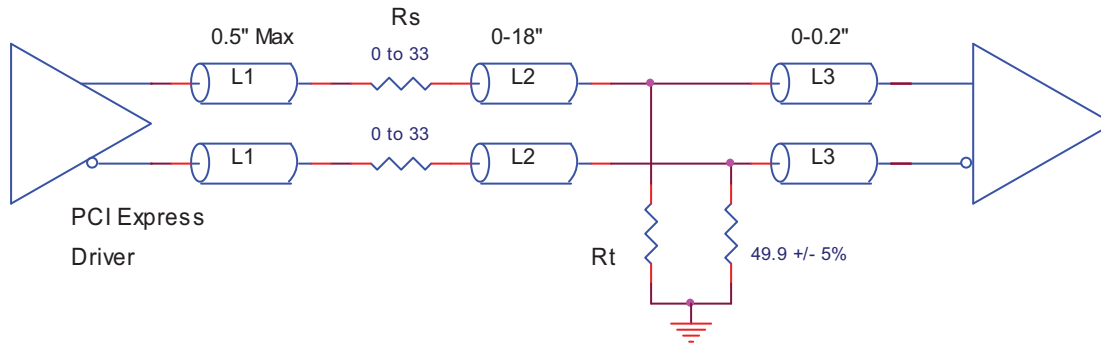

Figure 26 is the recommended termination for applications where a point-to-point connection can be used. A point-to-point connection contains both the driver and the receiver on the same PCB. With a matched termination at the receiver, transmission-line reflections will be minimized. In addition, a series resistor (R_s) at the driver offers flexibility and can help dampen unwanted reflections. The optional resistor can range from 0Ω to 33Ω. All traces should be 50Ω impedance single-ended or 100Ω differential.

Figure 26. Recommended Termination (Where a point-to-point connection can be used)



VFQFN EPAD Thermal Release Path

In order to maximize both the removal of heat from the package and the electrical performance, a land pattern must be incorporated on the Printed Circuit Board (PCB) within the footprint of the package corresponding to the exposed metal pad or exposed heat slug on the package, as shown in Figure 27. The solderable area on the PCB, as defined by the solder mask, should be at least the same size/shape as the exposed pad/slug area on the package to maximize the thermal/electrical performance. Sufficient clearance should be designed on the PCB between the outer edges of the land pattern and the inner edges of pad pattern for the leads to avoid any shorts.

While the land pattern on the PCB provides a means of heat transfer and electrical grounding from the package to the board through a solder joint, thermal vias are necessary to effectively conduct from the surface of the PCB to the ground plane(s). The land pattern must be connected to ground through these vias. The vias act as “heat pipes”. The number of vias (i.e. “heat pipes”) are application specific and dependent upon the package power dissipation as well as electrical conductivity requirements. Thus, thermal and electrical analysis and/or testing are recommended to determine the minimum number needed.

Maximum thermal and electrical performance is achieved when an array of vias is incorporated in the land pattern. It is recommended to use as many vias connected to ground as possible. It is also recommended that the via diameter should be 12 to 13mils (0.30 to 0.33mm) with 1oz copper via barrel plating. This is desirable to avoid any solder wicking inside the via during the soldering process which may result in voids in solder between the exposed pad/slug and the thermal land. Precautions should be taken to eliminate any solder voids between the exposed heat slug and the land pattern. Note: These recommendations are to be used as a guideline only. For further information, please refer to the Application Note on the Surface Mount Assembly of Amkor’s Thermally/ Electrically Enhance Lead frame Base Package, Amkor Technology.

Figure 27. P.C. Assembly for Exposed Pad Thermal Release Path – Side View (Drawing not to scale)

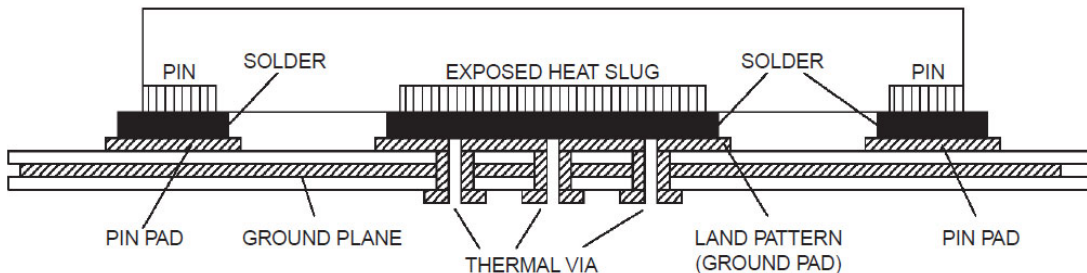

Schematic and Layout Information

Please contact IDT for schematic and layout information relevant to this product. Contact information can be found on the last page of this datasheet.

Crystal Recommendation

This device will be validated using FOX 277LF series through-hole crystals including Part # 277LF-40-18 (40MHz). If a surface mount crystal is desired, the FOX FX325BS series of crystals at an appropriate frequency, such as Part # 603-30-38 (40MHz), is recommended for use with this product.

PCI Express Application Note

PCI Express jitter analysis methodology models the system response to reference clock jitter. The block diagram below shows the most frequently used *Common Clock Architecture* in which a copy of the reference clock is provided to both ends of the PCI Express Link.

In the jitter analysis, the transmit (Tx) and receive (Rx) SerDes PLLs are modeled as well as the phase interpolator in the receiver. These transfer functions are called H1, H2, and H3 respectively. The overall system transfer function at the receiver is:

$$H_t(s) = H_3(s) \times [H_1(s) - H_2(s)]$$

The jitter spectrum seen by the receiver is the result of applying this system transfer function to the clock spectrum X(s) and is:

$$Y(s) = X(s) \times H_3(s) \times [H_1(s) - H_2(s)]$$

In order to generate time domain jitter numbers, an inverse Fourier Transform is performed on $X(s) \cdot H_3(s) \cdot [H_1(s) - H_2(s)]$.

Figure 28. PCI Express Common Clock Architecture

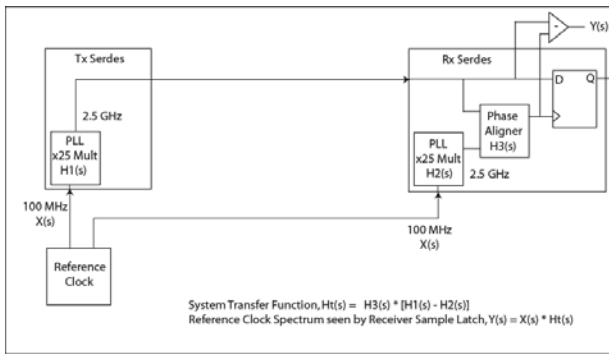

For PCI Express Gen 1, one transfer function is defined and the evaluation is performed over the entire spectrum: DC to Nyquist (e.g., for a 100MHz reference clock: 0Hz–50MHz) and the jitter result is reported in peak-peak.

Figure 29. PCIe Gen 1 Magnitude of Transfer Function

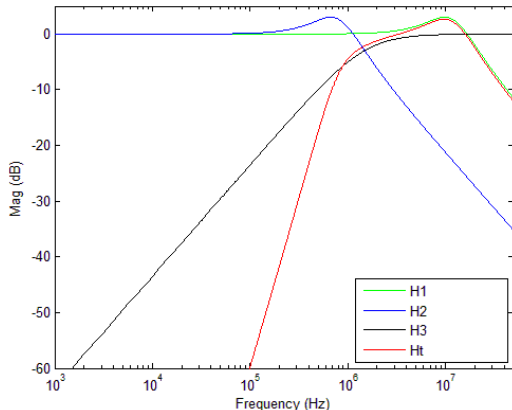

For PCI Express Gen 2, two transfer functions are defined with 2 evaluation ranges and the final jitter number is reported in RMS. The two evaluation ranges for PCI Express Gen 2 are 10kHz – 1.5MHz (Low Band) and 1.5MHz – Nyquist (High Band). The plots show the individual transfer functions as well as the overall transfer function Ht.

Figure 30. PCIe Gen 2A Magnitude of Transfer Function

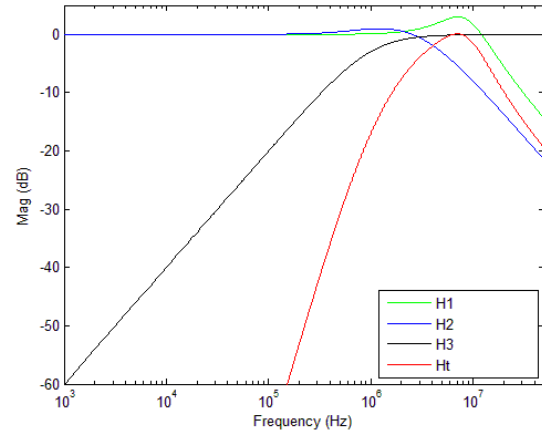
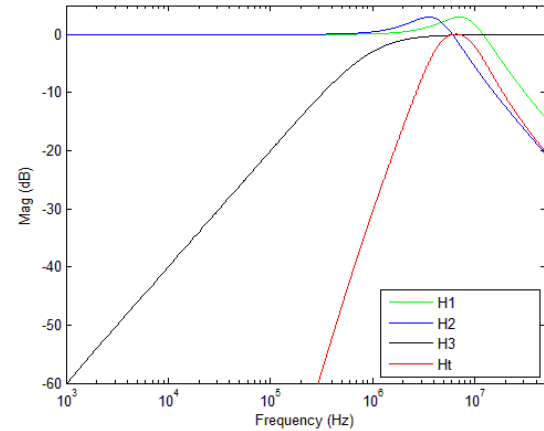
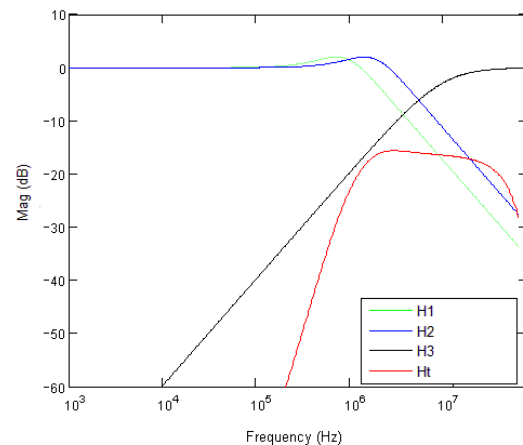

Figure 31. PCIe Gen 2B Magnitude of Transfer Function



For PCI Express Gen 3, one transfer function is defined and the evaluation is performed over the entire spectrum. The transfer function parameters are different from Gen 1 and the jitter result is reported in RMS.

Figure 32. PCIe Gen 3 Magnitude of Transfer Function



For a more thorough overview of PCI Express jitter analysis methodology, please refer to IDT Application Note, *PCI Express Reference Clock Requirements*.

Power Dissipation and Thermal Considerations

The 8T49N240 is a multi-functional, high-speed device that targets a wide variety of clock frequencies and applications. Since this device is highly programmable with a broad range of features and functionality, the power consumption will vary as these features and functions are enabled.

The 8T49N240 is designed and characterized to operate within the ambient industrial temperature range of -40°C to 85°C. The ambient temperature represents the temperature around the device, not the junction temperature. When using the device in extreme cases, such as maximum operating frequency and high ambient temperature, external air flow may be required in order to ensure a safe and reliable junction temperature. Extreme care must be taken to avoid exceeding a 125°C junction temperature.

The power calculation examples in this section are generated using maximum ambient temperature and supply voltage. For many applications, the power consumption will be much lower. For any concerns on calculating the power dissipation for your own specific configuration, please contact IDT technical support.

Power Domains

The 8T49N240 has a number of separate power domains that can be independently enabled and disabled via register accesses (all power supply pins must still be connected to a valid supply voltage). [Figure 33](#) indicates the individual domains and the associated power pins.

Figure 33. 8T49N240 Power Domains

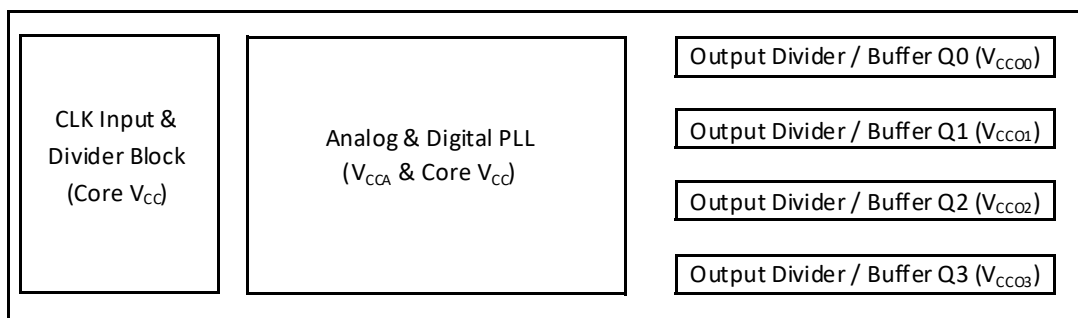

Power Consumption Calculation

The process of determining total power consumption involves the following steps:

1. Determine the power consumption using maximum current values for core and analog voltage supplies from [Table 26](#) and [Table 27](#).
2. Determine the nominal power consumption of each enabled output path, which consists of:
 - a. A base amount of power that is independent of operating frequency, as shown in [Table 42](#) to [Table 50](#) (depending on the chosen output protocol).
 - b. A variable amount of power that is related to the output frequency. This can be determined by multiplying the output frequency by the FQ_Factor shown in [Table 42](#) to [Table 50](#).
3. All of the above totals are summed.

Thermal Considerations

Once the total power consumption is determined, it is necessary to calculate the maximum operating junction temperature for the device under the environmental conditions it will operate in. Thermal conduction paths, air flow rate, and ambient air temperature are factors that can affect this calculation. The thermal conduction path refers to whether heat is to be conducted away via a heatsink, via airflow, or via conduction into the PCB through the device pads (including the ePAD). Thermal conduction data is provided for typical scenarios in [Table 41](#). For assistance with calculating results under other scenarios, please contact IDT technical support.

Table 41. Thermal Resistance θ_{JA} for 40-Lead VFQFN, Forced Convection

θ_{JA} by Velocity			
Meters per Second	0	1	2
Multi-Layer PCB, JEDEC Standard Test Boards	26.3°C/W	23.2°C/W	21.7°C/W

Current Consumption Data and Equations

Table 42. 3.3V LVPECL Output Calculation

Output	FQ_Factor (mA/MHz)	Base_Current (mA)
Q0	0.00642	41.9
Q1		
Q2		
Q3	0.00628	47.6

Table 43. 3.3V HCSL Output Calculation

Output	FQ_Factor (mA/MHz)	Base_Current (mA)
Q0	0.00567	42.0
Q1		
Q2		
Q3	0.00691	47.6

Table 44. 3.3V LVDS Output Calculation

Output	FQ_Factor (mA/MHz)	Base_Current (mA)
Q0	0.00586	51.5
Q1		
Q2		
Q3	0.00644	57.0

Table 45. 2.5V LVPECL Output Calculation

Output	FQ_Factor (mA/MHz)	Base_Current (mA)
Q0	0.00290	38.6
Q1		
Q2		
Q3	0.00493	43.8

Table 46. 2.5V HCSL Output Calculation

Output	FQ_Factor (mA/MHz)	Base_Current (mA)
Q0	0.00257	38.7
Q1		
Q2		
Q3	0.00505	43.7

Table 47. 2.5V LVDS Output Calculation

Output	FQ_Factor (mA/MHz)	Base_Current (mA)
Q0	0.00293	47.5
Q1		
Q2		
Q3	0.00467	52.6

Table 48. 3.3V LVCMOS Output Calculation

Output	Base_Current (mA)
Q3	43.42

Table 49. 2.5V LVCMOS Output Calculation

Output	Base_Current (mA)
Q3	40.54

Table 50. 1.8V LVCMOS Output Calculation

Output	Base_Current (mA)
Q3	38.83

Applying the values to the following equation will yield output current by frequency:

$$Q_x \text{ Current (mA)} = FQ_Factor * \text{Frequency (MHz)} + \text{Base_Current}$$

where:

Qx Current is the specific output current according to output type and frequency

FQ_Factor is used for calculating current increase due to output frequency

Base_Current is the base current for each output path independent of output frequency

The second step is to multiply the power dissipated by the thermal impedance to determine the maximum power gradient, using the following equation:

$$T_J = T_A + (\theta_{JA} * P_{d_{total}})$$

where:

T_J is the junction temperature (°C)

T_A is the ambient temperature (°C)

θ_{JA} is the thermal resistance value from [Table 41](#), dependent on ambient airflow (°C/W)

$P_{d_{total}}$ is the total power dissipation of the 8T49N240 under usage conditions, including power dissipated due to loading (W).

Note that the power dissipation per output pair due to loading is assumed to be 27.95mW for LVPECL outputs and 44.5mW for HCSL outputs. When selecting LVCMOS outputs, power dissipation through the load will vary based on a variety of factors including termination type and trace length. For these examples, power dissipation through loading will be calculated using C_{PD} (found in [Table 26](#)) and output frequency:

$$P_{d_{OUT}} = C_{PD} * F_{OUT} * V_{CCO}^2$$

where:

$P_{d_{OUT}}$ is the power dissipation of the output (W)

C_{PD} is the power dissipation capacitance (F)

F_{OUT} is the output frequency of the selected output (Hz)

V_{CCO} is the voltage supplied to the appropriate output (V)

Example Calculations

Table 51. Example 1: Common Customer Configuration (3.3V Core Voltage)

Output	Output Type	Frequency (MHz)	V _{CC0}
Q0	LVPECL	125	3.3
Q1	Disabled	Disabled	3.3
Q2	LVPECL	50	3.3
Q3	LVPECL	100	3.3

- Core Supply Current + Control and Status Supply Current = $I_{CC} + I_{CCCS} = 58\text{mA (max)}$
- Analog Supply Current, $I_{CCA} = 186\text{mA (max)}$
- Output Supply Current:
 - Q0 Current = $125 * 0.00642 + 41.9 = 42.7\text{mA}$
 - Q1 Current = 0mA (Output disabled)
 - Q2 Current = $50 * 0.00642 + 41.9 = 42.2\text{mA}$
 - Q3 Current = $100 * 0.00628 + 47.6 = 48.2\text{mA}$
- Total Output Supply Current = 133.1mA (max)
- Total Device Current = $58\text{mA} + 186\text{mA} + 133.1\text{mA} = 377.1\text{mA}$
- Total Device Power = $3.465\text{V} * 377.1\text{mA} = 1306.7\text{mW}$
- Power dissipated through output loading:
 - LVPECL = $27.95\text{mW} * 3 = 83.85\text{mW}$
 - LVDS = already accounted for in device power
 - HCSL = n/a
 - LVC MOS = n/a
- Total Power = $1306.7\text{mW} + 83.85\text{mW} = 1390.6\text{mW}$ or 1.4W

With an ambient temperature of 85°C and no airflow, the junction temperature is:

$$T_J = 85^\circ\text{C} + 26.3^\circ\text{C/W} * 1.4\text{W} = 122^\circ\text{C}$$

This is below the limit of 125°C.

Table 52. Example 2: Common Customer Configuration (2.5V Core Voltage)

Output	Output Type	Frequency (MHz)	V _{CC0}
Q0	LVPECL	156.25	2.5
Q1	LVDS	125	2.5
Q2	HCSL	125	2.5
Q3	LVC MOS	25	2.5

- Core Supply Current + Control and Status Supply Current = $I_{CC} + I_{CCCS} = 55\text{mA (max)}$
- Analog Supply Current, $I_{CCA} = 179\text{mA (max)}$
- Output Supply Current:
 - Q0 Current = $156.25 * 0.00290 + 38.6 = 39.0\text{mA}$
 - Q1 Current = $125 * 0.00293 + 47.5 = 47.9\text{mA}$
 - Q2 Current = $125 * 0.00257 + 38.7 = 39\text{mA}$
 - Q3 Current = 40.5mA
- Total Output Supply Current = 166.4mA (max)
- Total Device Current = $55\text{mA} + 179\text{mA} + 166.4\text{mA} = 400.4\text{mA}$
- Total Device Power = $2.625\text{V} * 400.4\text{mA} = 1051\text{mW}$
- Power dissipated through output loading:
 - LVPECL = $27.95\text{mW} * 1 = 27.95\text{mW}$
 - LVDS = already accounted for in device power
 - HCSL = $45.5\text{mW} * 1 = 44.5\text{mW}$
 - LVC MOS = $15\text{pF} * 25\text{MHz} * (2.625\text{V})^2 * 1 \text{ output pair} = 2.58\text{mW}$
- Total Power = $1051\text{mW} + 27.95\text{mW} + 44.5\text{mW} + 2.58\text{mW} = 1126\text{mW}$ or 1.13W

With an ambient temperature of 85°C and no airflow, the junction temperature is:

$$T_J = 85^\circ\text{C} + 26.3^\circ\text{C/W} * 1.13\text{W} = 114.7^\circ\text{C}$$

This is below the limit of 125°C.

Table 53. Example 3: Common Customer Configuration (2.5V Core Voltage)

Output	Output Type	Frequency (MHz)	V _{CCO}
Q0	LVPECL	156.25	3.3
Q1	LVDS	156.25	2.5
Q2	HCSL	50	3.3
Q3	LVC MOS	33.333	1.8

- Core Supply Current + Control and Status Supply Current = $I_{CC} + I_{CCCS} = 55\text{mA (max)}$
- Analog Supply Current, $I_{CCA} = 179\text{mA (max)}$
- Output Supply Current:
 - Q0 Current = $156.25 * 0.00642 + 41.9 = 42.9\text{mA}$
 - Q1 Current = $156.25 * 0.00293 + 47.5 = 48.0\text{mA}$
 - Q2 Current = $50 * 0.00567 + 42.0 = 42.3\text{mA}$
 - Q3 Current = 38.8mA
- Total Output Supply Current = $85.2\text{mA (V}_{CCO} = 3.3\text{V}), 48\text{mA (V}_{CCO} = 2.5\text{V}), 38.8\text{mA (V}_{CCO} = 1.8\text{V})$
 Total Device Current:
 - 3.3V: 85.2mA
 - 2.5V: $55\text{mA} + 179\text{mA} + 48\text{mA} = 282\text{mA}$
 - 1.8V: 38.8mA
- Total Device Power = $3.465\text{V} * 85.2\text{mA} + 2.625\text{V} * 282\text{mA} + 1.89\text{V} * 38.8\text{mA} = 1108.8\text{mW}$
- Power dissipated through output loading:
 - LVPECL = $27.95\text{mW} * 1 = 27.95\text{mW}$
 - LVDS = already accounted for in device power
 - HCSL = $45.5\text{mW} * 1 = 45.5\text{mW}$
 - LVC MOS = $15\text{pF} * 33.333\text{MHz} * (1.89\text{V})^2 * 1 \text{ output pair} = 1.79\text{mW}$
- Total Power = $1108.8\text{mW} + 27.95\text{mW} + 44.5\text{mW} + 1.79\text{mW} = 1183\text{mW}$ or 1.2W

With an ambient temperature of 85°C and no airflow, the junction temperature is:

$$T_J = 85^{\circ}\text{C} + 26.3^{\circ}\text{C/W} * 1.2\text{W} = 116.6^{\circ}\text{C}$$

This is below the limit of 125°C .

Reliability Information

Table 54. θ_{JA} vs. Air Flow for a 40-VFQFN^[a]

θ_{JA} vs. Air Flow			
Meters per Second	0	1	2
Multi-Layer PCB, JEDEC Standard Test Boards	26.3°C/W	23.2°C/W	21.7°C/W

[a] Assumes 5x5 grid of solder balls under ePAD area for thermal condition.

Transistor Count

The transistor count for 8T49N240 is: 537,496.

Package Outlines Drawings

The package outline drawings are appended at the end of this document and are accessible from the link below. The package information is the most current data available.

www.idt.com/document/psc/40-vfqfn-package-outline-drawing-60-x-60-x-09-mm-05mm-pitch-465-x-465-mm-epad-nlnlg40p2

Marking Diagram

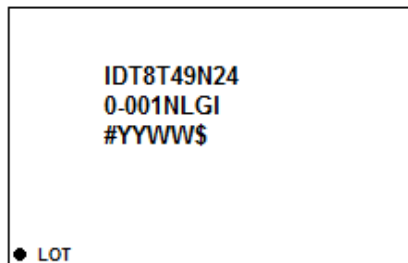

- Line 1 and Line 2 indicate the part number. "001" will vary due to configuration.
- Line 3 indicates the following:
 - # denotes sequential lot number.
 - "YYWW" is the last two digits of the year and week that the part was assembled.
 - "\$" denotes the mark code.

Ordering Information

Part/Order Number ^[a]	Marking	Package ^[b]	Shipping Packaging	Temperature
8T49N240-dddNLGI	IDT8T49N240NLGI	6 x 6 x 0.9 mm 40-VFQFN	Tray	-40°C to +85°C
8T49N240-dddNLGI8	IDT8T49N240NLGI	6 x 6 x 0.9 mm 40-VFQFN, Quadrant 1	Tape and Reel	-40°C to +85°C
8T49N240-dddNLGI#	IDT8T49N240NLGI	6 x 6 x 0.9 mm 40-VFQFN, Quadrant 2	Tape and Reel	-40°C to +85°C

[a] For the specific -ddd order codes, refer to *FemtoClock NG Universal Frequency Translator Ordering Product Information*.

[b] For information about Pin 1 Orientation in Tape and Reel Packaging, see [Table 55](#).

Table 55. Pin 1 Orientation in Tape and Reel Packaging

Part Number Suffix	Pin 1 Orientation	Illustration
NLG18	Quadrant 1 (EIA-481-C)	<p>Correct Pin 1 ORIENTATION</p> <p>CARRIER TAPE TOPSIDE (Round Sprocket Holes)</p> <p>USER DIRECTION OF FEED</p>
NLG#	Quadrant 2 (EIA-481-D)	<p>Correct Pin 1 ORIENTATION</p> <p>CARRIER TAPE TOPSIDE (Round Sprocket Holes)</p> <p>USER DIRECTION OF FEED</p>

Revision History

Revision Date	Description of Change
January 15, 2018	Corrected I ² C read sequence diagrams in Figure 3 and Figure 4 to match I ² C specification and device actual performance. Note: Only the drawings were incorrect – the part's behavior did not change and continues to meet the I ² C specification.
July 30, 2018	<ul style="list-style-type: none"> ▪ Per PCN# N1807-01, effective date August 19, 2018 ▪ Updated the package outline drawings; however, no technical changes
December 8, 2017	<ul style="list-style-type: none"> ▪ Updated the titles of Table 38 and Table 39 ▪ Completed other minor document changes
November 7, 2017	<ul style="list-style-type: none"> ▪ Updated I2C Mode Operation to indicate support for v2.1 of the <i>I²C Specification</i> ▪ Added a note before Table 22 (Digital PLL Status Register Bit Field Locations) ▪ Added the following fields to the Digital PLL Status Register: NO_REF, CURR_REF, PLLLCK, and SM_STS ▪ Added a marking diagram
August 3, 2017	Completed minor changes.
August 2, 2017	Added the C _{XTAL} symbol to Table 2 .
May 31, 2017	Initial release.

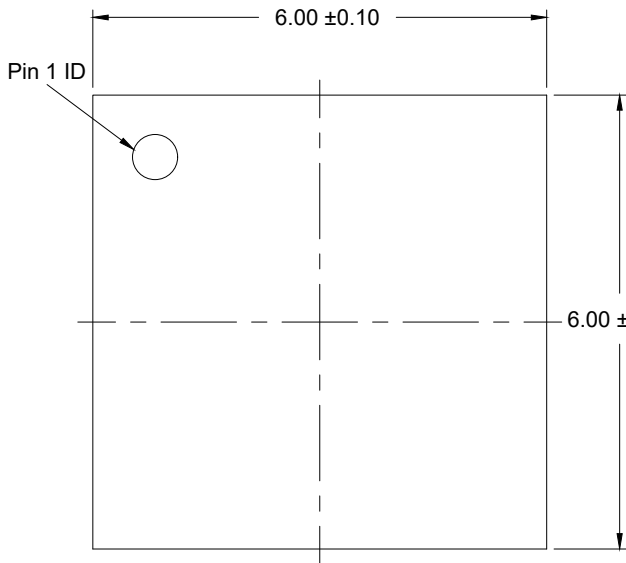

Top View

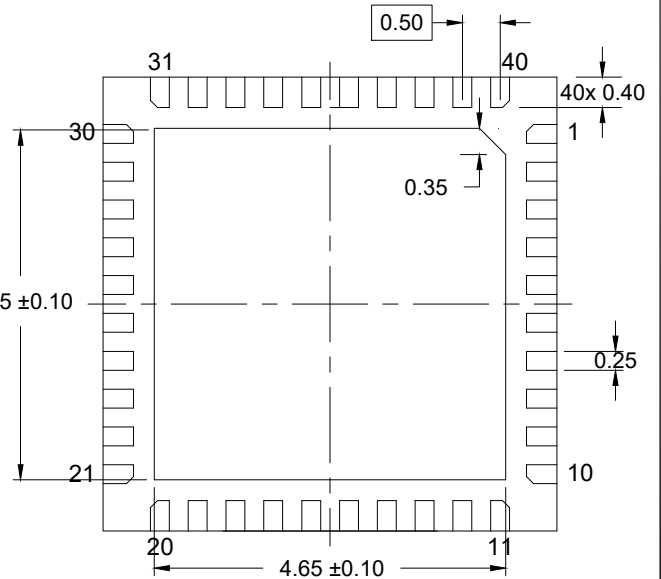

Bottom View

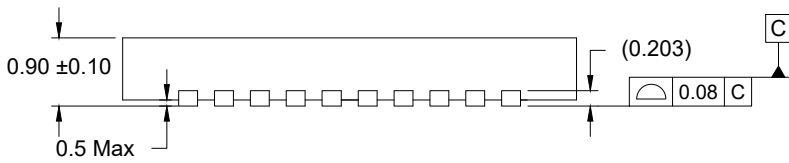

Side View

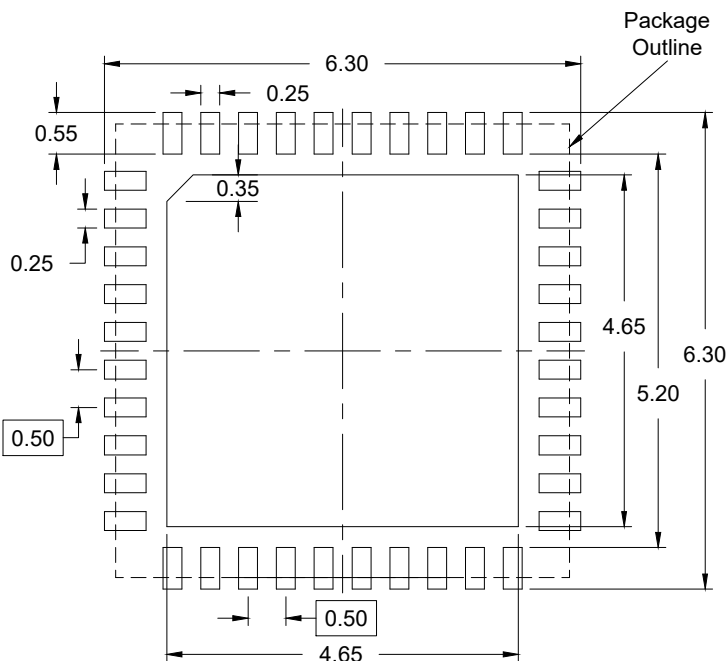

Recommended Land Pattern
(PCB Top View, NSMD Design)

NOTES:

1. JEDEC compatible.
2. All dimensions are in mm and angles are in degrees.
3. Use ± 0.05 mm for the non-toleranced dimensions.
4. Number in () are for references only.

IMPORTANT NOTICE AND DISCLAIMER

RENESAS ELECTRONICS CORPORATION AND ITS SUBSIDIARIES (“RENESAS”) PROVIDES TECHNICAL SPECIFICATIONS AND RELIABILITY DATA (INCLUDING DATASHEETS), DESIGN RESOURCES (INCLUDING REFERENCE DESIGNS), APPLICATION OR OTHER DESIGN ADVICE, WEB TOOLS, SAFETY INFORMATION, AND OTHER RESOURCES “AS IS” AND WITH ALL FAULTS, AND DISCLAIMS ALL WARRANTIES, EXPRESS OR IMPLIED, INCLUDING, WITHOUT LIMITATION, ANY IMPLIED WARRANTIES OF MERCHANTABILITY, FITNESS FOR A PARTICULAR PURPOSE, OR NON-INFRINGEMENT OF THIRD-PARTY INTELLECTUAL PROPERTY RIGHTS.

These resources are intended for developers who are designing with Renesas products. You are solely responsible for (1) selecting the appropriate products for your application, (2) designing, validating, and testing your application, and (3) ensuring your application meets applicable standards, and any other safety, security, or other requirements. These resources are subject to change without notice. Renesas grants you permission to use these resources only to develop an application that uses Renesas products. Other reproduction or use of these resources is strictly prohibited. No license is granted to any other Renesas intellectual property or to any third-party intellectual property. Renesas disclaims responsibility for, and you will fully indemnify Renesas and its representatives against, any claims, damages, costs, losses, or liabilities arising from your use of these resources. Renesas' products are provided only subject to Renesas' Terms and Conditions of Sale or other applicable terms agreed to in writing. No use of any Renesas resources expands or otherwise alters any applicable warranties or warranty disclaimers for these products.

(Disclaimer Rev.1.01 Jan 2024)

Corporate Headquarters

TOYOSU FORESIA, 3-2-24 Toyosu,
Koto-ku, Tokyo 135-0061, Japan
www.renesas.com

Trademarks



Renesas and the Renesas logo are trademarks of Renesas Electronics Corporation. All trademarks and registered trademarks are the property of their respective owners.

Contact Information

For further information on a product, technology, the most up-to-date version of a document, or your nearest sales office, please visit www.renesas.com/contact-us/.

Looking for pricing, stock, or lifecycle information?

Click below to explore more details on WIN SOURCE:

-  [View 8T49N240-026NLGI on WIN SOURCE](#)
-  [Renesas Electronics America](#) Information

Optimize Your Supply Chain with WIN SOURCE Solutions

-  Global Sourcing Solution
-  Obsolete Management
-  Cost Control Management
-  Shortage Management
-  Alternative Solution
-  Excess Inventory Management