



**THE DATASHEET OF  
8T49N012NLGI**



### General Description

The 8T49N012 is a high performance Clock Generator with selectable LVPECL or Single-ended outputs. The 8T49N012 can generate selectable frequencies from a crystal or a single-ended reference clock. The frequency is selected from the Frequency Selection Table.

Excellent phase noise performance is maintained with IDT's Fourth Generation FemtoClock® NG PLL technology.

### Features

- Fourth Generation FemtoClock NG PLL technology
- Three differential output banks:
  - Bank A:** selectable between four pairs of LVPECL or four pairs of complementary LVCMOS/LVTTL outputs
  - Bank B:** two pairs of LVPECL outputs
  - Bank C:** six pairs of LVPECL outputs
- Selectable clock input or crystal input.
- Supports 25MHz fundamental crystal or 25MHz, 50MHz, 66.67MHz clock input
- Selectable 156.25MHz, 125MHz, 100MHz clock for Bank B and Bank C outputs
- Selectable 156.25MHz, 125MHz, 100MHz, 250MHz, 312.5MHz, 50MHz, 25MHz, 62.5MHz or 78.125MHz for Bank A outputs
- PLL lock indication (LVCMOS output)
- RMS phase jitter at 156.25MHz (12kHz - 20MHz): 0.199ps (typical)
- Power supply modes:
  - Core / Output
  - 3.3V / 3.3V
  - 3.3V / 2.5V
  - 2.5V / 2.5V
- -40°C to 85°C ambient operating temperature
- 56-Lead VFQFN
- Lead-free (RoHS 6) packaging

### Pin Assignment

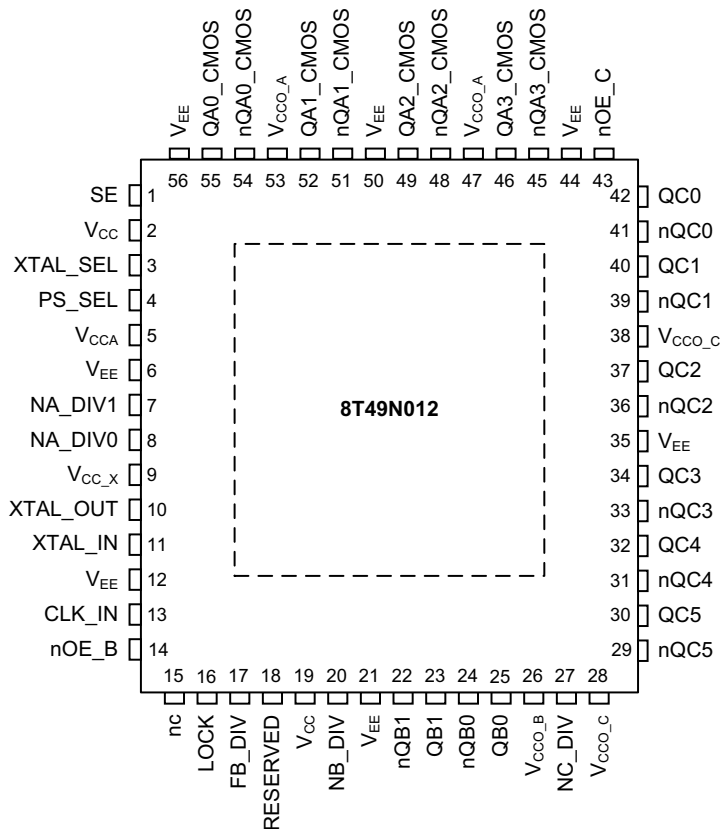

56-Lead VFQFN, 8.0mm x 8.0mm x 0.9mm

## Block Diagram

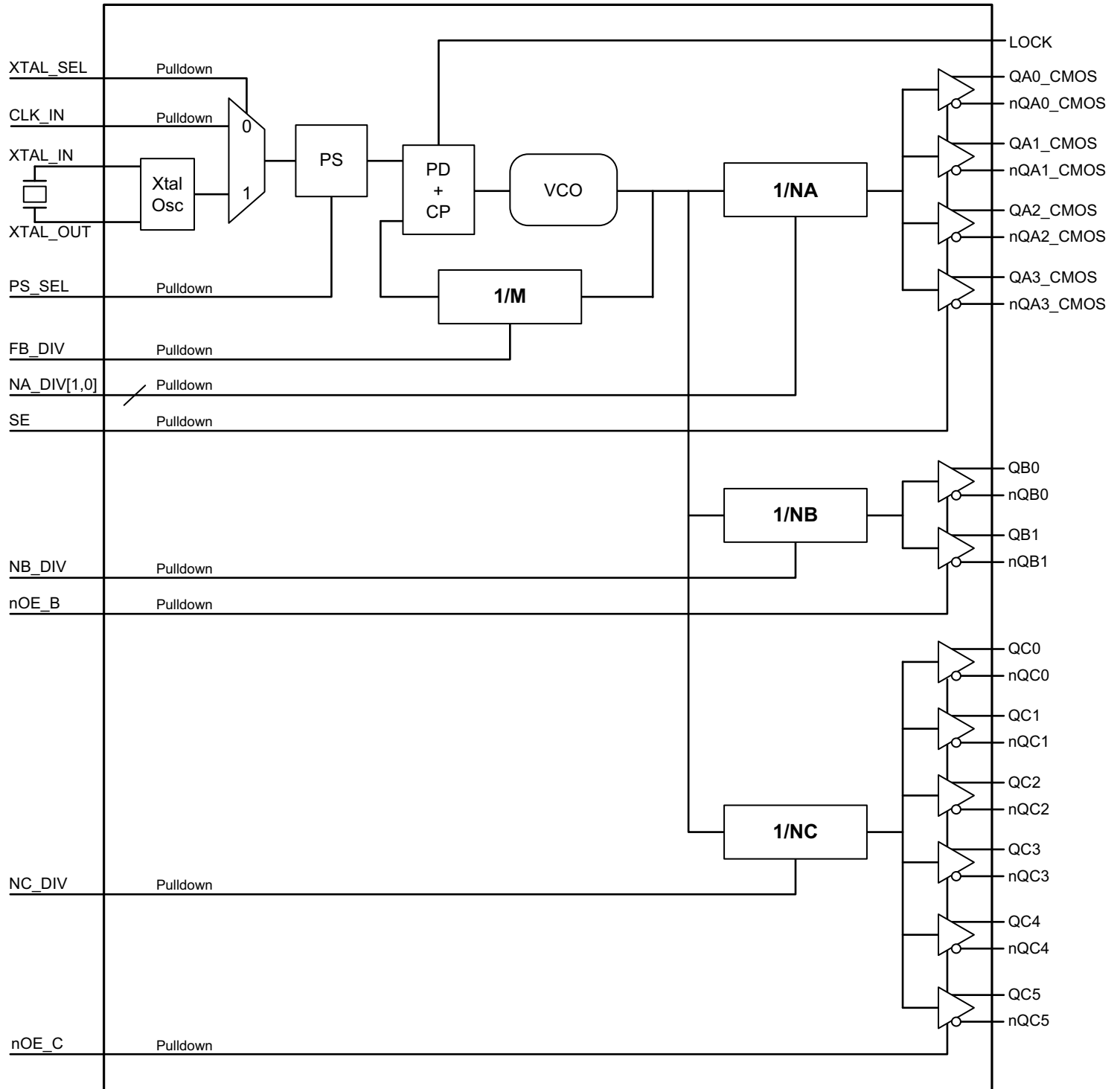

## Pin Description and Pin Characteristic Tables

Table 1. Pin Descriptions<sup>1</sup>

Number	Name	Type		Description
1	SE	Input	Pulldown	Select pin for Bank A outputs. LVCMOS/LVTTL interface levels. See the <a href="#">Function Configuration Tables</a> section.
2	V <sub>CC</sub>	Power		Core power supply pins.
3	XTAL_SEL	Input	Pulldown	Select reference source between the crystal or input clock. LVCMOS/LVTTL interface levels. See the <a href="#">Function Configuration Tables</a> section.
4	PS_SEL	Input	Pulldown	Pre scale divider selection. LVCMOS/LVTTL interface levels. See the <a href="#">Function Configuration Tables</a> section.
5	V <sub>CCA</sub>	Power		Analog supply for VCO.
6	V <sub>EE</sub>	Power		Negative power supply pin.
7	NA_DIV1	Input	Pulldown	Select output frequency for Bank A outputs. LVCMOS/LVTTL interface levels. See the <a href="#">Function Configuration Tables</a> section.
8	NA_DIV0	Input	Pulldown	Select output frequency for Bank A outputs. LVCMOS/LVTTL interface levels. See the <a href="#">Function Configuration Tables</a> section.
9	V <sub>CC_X</sub>	Power		Crystal oscillator power supply pin.
10	XTAL_OUT	O/I		Crystal oscillator interface output.
11	XTAL_IN	O/I		Crystal oscillator interface input.
12	V <sub>EE</sub>	Power		Negative power supply pin.
13	CLK_IN	Input	Pulldown	Single-ended input clock. LVCMOS/LVTTL interface levels.
14	nOE_B	Input	Pulldown	Output enable for Bank B outputs. LVCMOS/LVTTL interface levels. See the <a href="#">Function Configuration Tables</a> section.
15	nc	unused		No connect pin.
16	LOCK	Output		PLL lock indicator. Logic High indicates PLL is locked. LVCMOS/LVTTL interface levels. See the <a href="#">Function Configuration Tables</a> section.
17	FB_DIV	Input	Pulldown	Feedback divider selection. LVCMOS/LVTTL interface levels. See the <a href="#">Function Configuration Tables</a> section.
18	RESERVED	Reserve		Reserve pin. Do not connect.
19	V <sub>CC</sub>	Power		Core power supply pin.
20	NB_DIV	Input	Pulldown	Select output frequency for Bank B outputs. LVCMOS/LVTTL interface levels. See the <a href="#">Function Configuration Tables</a> section.
21	V <sub>EE</sub>	Power		Negative power supply pin.
22	nQB1	Output		Differential Bank B outputs. LVPECL interface levels.
23	QB1	Output		
24	nQB0	Output		
25	QB0	Output		
26	V <sub>CCO_B</sub>	Power		Bank B output power supply pin.
27	NC_DIV	Input	Pulldown	Select output frequency for Bank C outputs. LVCMOS/LVTTL interface levels. See the <a href="#">Function Configuration Tables</a> section.
28	V <sub>CCO_C</sub>	Power		Bank C output power supply pin.
29	nQC5	Output		Differential Bank C outputs. LVPECL interface levels.
30	QC5	Output		

**Table 1. Pin Descriptions<sup>1</sup> (Continued)**

Number	Name	Type		Description
31	nQC4	Output		Differential Bank C outputs. LVPECL interface levels.
32	QC4	Output		
33	nQC3	Output		Differential Bank C outputs. LVPECL interface levels.
34	QC3	Output		
35	V <sub>EE</sub>	Power		Negative power supply pin.
36	nQC2	Output		Differential Bank C outputs. LVPECL interface levels.
37	QC2	Output		
38	V <sub>CCO_C</sub>	Power		Bank C output power supply pin.
39	nQC1	Output		Differential Bank C outputs. LVPECL interface levels.
40	QC1	Output		
41	nQC0	Output		Differential Bank C outputs. LVPECL interface levels.
42	QC0	Output		
43	nOE_C	Input	Pulldown	Output enable for Bank C outputs. LVCMOS/LVTTL interface levels. See the <a href="#">Function Configuration Tables</a> section.
44	V <sub>EE</sub>	Power		Negative power supply pin.
45	nQA3_CMOS	Output		Selectable LVPECL differential or complementary LVCMOS/LVTTL Bank A outputs.
46	QA3_CMOS	Output		
47	V <sub>CCO_A</sub>	Power		Bank A output power supply pin.
48	nQA2_CMOS	Output		Selectable LVPECL differential or complementary LVCMOS/LVTTL Bank A outputs.
49	QA2_CMOS	Output		
50	V <sub>EE</sub>	Power		Negative power supply pin.
51	nQA1_CMOS	Output		Selectable LVPECL differential or complementary LVCMOS/LVTTL Bank A outputs.
52	QA1_CMOS	Output		
53	V <sub>CCO_A</sub>	Power		Bank A output power supply pin.
54	nQA0_CMOS	Output		Selectable LVPECL differential or complementary LVCMOS/LVTTL Bank A outputs.
55	QA0_CMOS	Output		
56	V <sub>EE</sub>	Power		Negative power supply pin.
E-Pad	V <sub>EE</sub>	Power		Negative power supply pin.

NOTE 1: *Pulldown* refers to internal input resistors. See Table 2, *Pin Characteristics*, for typical values.

**Table 2. Pin Characteristics**

Symbol	Parameter		Test Conditions	Minimum	Typical	Maximum	Units
C <sub>IN</sub>	Input Capacitance		Input Control Pins		3.5		pF
R <sub>PULLDOWN</sub>	Input Pulldown Resistor				51		kΩ
C <sub>PD</sub>	Power Dissipation Capacitance (per output)		V <sub>CC</sub> , V <sub>CC_X</sub> , V <sub>CCO_A</sub> = 3.465V		6.5		pF
			V <sub>CC</sub> , V <sub>CC_X</sub> = 3.465V, V <sub>CCO_A</sub> = 2.625V		6.5		pF
R <sub>out</sub>	LVCMOS Output Impedance	QA[0:3]_CMOS, nQA[0:3]_CMOS	V <sub>CCO_A</sub> = 3.3V ± 5%		26		Ω
			V <sub>CCO_A</sub> = 2.5V ± 5%		30		Ω

## Function Configuration Tables

**Table 3A. FB\_DIV Function Table**

FB_DIV	Feedback Divider
Low (default)	50
Mid	75
High	100

**Table 3B. SE Function Table**

SE	Bank A Output
Low (default)	Differential output
Mid	High Impedance
High	LVC MOS output

**Table 3C. XTAL\_SEL Function Table**

XTAL_SEL	Bank A Output
Low (default)	CLK_IN
High	XTAL

**Table 3D. LOCK indicaiotn Table**

LOCK	PLL Status
Low	PLL is Out of Lock
High	PLL is Locked

**Table 3E. nQE\_B Function Table**

nOE_B	Bank B Output
Low (default)	LVPECL
Mid (Reserved)	Reserved
High	High Impedance

**Table 3F. nOE\_C Function Table**

nOE_C	Bank C Output
Low (default)	LVPECL
Mid (Reserved)	Reserved
High	High Impedance

**Table 3G. Bank B and C Output Divider Table**

Input Frequency (MHz)	PS_SEL	FB_DIV	NB_DIV	Bank B Frequency (MHz)	NC_DIV	Bank C Frequency (MHz)
25	Low (default)	Low (default)	Low (default)	125	Low (default)	125
			Mid	100	Mid	100
			High	156.25	High	156.25
66.66667	Mid	Mid	Low (default)	125	Low (default)	125
			Mid	100	Mid	100
			High	156.25	High	156.25
50	High	Low	Low (default)	125	Low (default)	125
			Mid	100	Mid	100
			High	156.25	High	156.25

**Table 3H. Bank A Output Divider table**

Input Frequency (MHz)	PS_SEL	FB_DIV	NA_DIV [1:0]	Bank A Frequency (MHz)
25	Low (default)	Low (default)	Low, Low (default)	125
			Low, High	156.25
			High, Low	312.5
			High, High	100
			Low, Mid	25
			High, Mid	50
			Mid, Low	250
			Mid, High	62.5
			Mid, Mid	78.125
66.66667	Mid	Mid	Low, Low (default)	125
			Low, High	156.25
			High, Low	312.5
			High, High	100
			Low, Mid	25
			High, Mid	50
			Mid, Low	250
			Mid, High	62.5
			Mid, Mid	78.125
50	High	Low	Low, Low (default)	125
			Low, High	156.25
			High, Low	312.5
			High, High	100
			Low, Mid	25
			High, Mid	50
			Mid, Low	250
			Mid, High	62.5
			Mid, Mid	78.125

## Absolute Maximum Ratings

NOTE: Stresses beyond those listed under *Absolute Maximum Ratings* may cause permanent damage to the device. These ratings are stress specifications only. Functional operation of the product at these conditions or any conditions beyond those listed in the *DC Electrical Characteristics* or *AC Electrical Characteristics* is not implied. Exposure to absolute maximum rating conditions for extended periods may affect product reliability.

Item	Rating
Supply Voltage, $V_{CC}$	3.6V
Inputs, $V_I$ XTAL_IN Other Input	0V to 2V -0.5V to $V_{CC} + 0.5V$
Outputs, $V_O$ (LVCMOS)	-0.5V to $V_{CCO\_A} + 0.5V$
Outputs, $I_O$ (LVPECL) Continuous Current Surge Current	50mA 100mA
Thermal Junction Temperature, $T_J$	125°C
Storage Temperature, $T_{STG}$	-65°C to 150°C

## DC Electrical Characteristics

**Table 4A. Power Supply DC Characteristics,  $V_{CC} = V_{CC\_X} = V_{CCO\_X}^1 = 3.3V \pm 5\%$ ,  $V_{EE} = 0V$ ,  $T_A = -40^\circ C$  to  $85^\circ C$**

Symbol	Parameter	Test Conditions	Minimum	Typical	Maximum	Units
$V_{CC}$	Core Supply Voltage		3.135	3.3	3.465	V
$V_{CC\_X}$	XTAL Supply Voltage		3.135	3.3	3.465	V
$V_{CCA}$	Analog Supply Voltage		3.135	3.3	3.465	V
$V_{CCO\_X}$	Output Supply Voltage		3.135	3.3	3.465	V
$I_{CCA}$	Analog Supply Current			42	50	mA
$I_{EE}$	Power Supply Current	Unterminated Outputs		332	381	mA

NOTE 1:  $V_{CCO\_X}$  denotes  $V_{CCO\_A}$ ,  $V_{CCO\_B}$  and  $V_{CCO\_C}$ ,

**Table 4B. Power Supply DC Characteristics,  $V_{CC} = V_{CC\_X} = V_{CCO\_X}^1 = 2.5V \pm 5\%$ ,  $V_{EE} = 0V$ ,  $T_A = -40^\circ C$  to  $85^\circ C$**

Symbol	Parameter	Test Conditions	Minimum	Typical	Maximum	Units
$V_{CC}$	Core Supply Voltage		2.375	2.5	2.625	V
$V_{CC\_X}$	XTAL Supply Voltage		2.375	2.5	2.625	V
$V_{CCA}$	Analog Supply Voltage		2.375	2.5	2.625	V
$V_{CCO\_X}$	Output Supply Voltage		2.375	2.5	2.625	V
$I_{CCA}$	Analog Supply Current			32	41	mA
$I_{EE}$	Power Supply Current	Unterminated Outputs		306	354	mA

NOTE 1:  $V_{CCO\_X}$  denotes  $V_{CCO\_A}$ ,  $V_{CCO\_B}$  and  $V_{CCO\_C}$ ,

**Table 4C. Power Supply DC Characteristics,  $V_{CC} = V_{CC\_X} = 3.3V \pm 5\%$ ,  $V_{CCO\_X}^1 = 2.5V \pm 5\%$ ,  $V_{EE} = 0V$ ,  $T_A = -40^\circ C$  to  $85^\circ C$** 

Symbol	Parameter	Test Conditions	Minimum	Typical	Maximum	Units
$V_{CC}$	Core Supply Voltage		3.135	3.3	3.465	V
$V_{CC\_X}$	XTAL Supply Voltage		3.135	3.3	3.465	V
$V_{CCA}$	Analog Supply Voltage		3.135	3.3	3.465	V
$V_{CCO\_X}$	Output Supply Voltage		2.375	2.5	2.625	V
$I_{CCA}$	Analog Supply Current			42	50	mA
$I_{EE}$	Power Supply Current	Unterminated Outputs		323	373	mA

NOTE 1:  $V_{CCO\_X}$  denotes  $V_{CCO\_A}$ ,  $V_{CCO\_B}$  and  $V_{CCO\_C}$ ,

**Table 4D. 2-Level LVCMOS/LVTTL DC Characteristics,  $T_A = -40^\circ C$  to  $85^\circ C$** 

Symbol	Parameter	Test Conditions	Minimum	Typical	Maximum	Units
$V_{IH}$	Input High Voltage	$V_{CC} = 3.3V$	2		$V_{CC} + 0.3$	V
		$V_{CC} = 2.5V$	1.7		$V_{CC} + 0.3$	V
$V_{IL}$	Input Low Voltage	$V_{CC} = 3.3V$	-0.3		0.8	V
		$V_{CC} = 2.5V$	-0.3		0.7	V
$I_{IH}$	Input High Current	CLK_IN, XTAL_SEL $V_{CC} = V_{IN} = 3.465V$ or $2.625V$			150	$\mu A$
$I_{IL}$	Input Low Current	CLK_IN, XTAL_SEL $V_{CC} = 3.465V$ or $2.625V$ , $V_{IN} = 0V$	-5			$\mu A$
$V_{OH}$	Output High Voltage	QA[0:3]_CMOS, nQA[0:3]_CMOS, LOCK $V_{CCO\_A} = 3.465V$ ; $I_{OH} = -8mA$	2.6			V
$V_{OL}$	Output Low Voltage	QA[0:3]_CMOS, nQA[0:3]_CMOS, LOCK $V_{CCO\_A} = 3.465V$ ; $I_{OL} = 8mA$			0.6	V

**Table 4E. 3-Level LVCMOS/LVTTL DC Characteristics,  $T_A = -40^\circ C$  to  $85^\circ C$** 

Symbol	Parameter	Test Conditions	Minimum	Typical	Maximum	Units
$V_{IH}$	Input High Voltage		$0.85 * V_{CC}$			V
$V_{IL}$	Input Low Voltage				$0.15 * V_{CC}$	V
$V_{IM}$	Input middle Voltage		$0.45 * V_{CC}$		$0.55 * V_{CC}$	V
$I_{IH}$	Input High Current	nOE_B, nOE_C, NA_DIVx, NB_DIV, NC_DIV, PS_SEL, SE $V_{CC} = V_{IN} = 3.465V$ or $2.625V$			150	$\mu A$
$I_{IL}$	Input Low Current	nOE_B, nOE_C, NA_DIVx, NB_DIV, NC_DIV, PS_SEL, SE $V_{CC} = 3.465V$ or $2.625V$ , $V_{IN} = 0V$	-5			$\mu A$
$I_{IM}$	Input Middle Current	nOE_B, nOE_C, NA_DIVx, NB_DIV, NC_DIV, PS_SEL, SE $V_{CC} = 3.465V$ or $2.625V$ , $V_{IN} = 0.5 * V_{CC}$			150	$\mu A$

**Table 4F. LVPECL DC Characteristics,  $V_{CCO\_X}^1 = 3.3V \pm 5\%$ ,  $V_{EE} = 0V$ ,  $T_A = -40^\circ C$  to  $85^\circ C$**

Symbol	Parameter	Test Conditions	Minimum	Typical	Maximum	Units
$V_{OH}$	Output High Voltage <sup>2</sup>		$V_{CCO\_X} - 1.1$		$V_{CCO\_X} - 0.7$	V
$V_{OL}$	Output Low Voltage <sup>2</sup>		$V_{CCO\_X} - 2.0$		$V_{CCO\_X} - 1.6$	V
$V_{SWING}$	Peak-to-Peak Output Voltage Swing		0.6		1.0	V

NOTE 1:  $V_{CCO\_X}$  denotes  $V_{CCO\_A}$ ,  $V_{CCO\_B}$  and  $V_{CCO\_C}$ ,

NOTE 2: Outputs termination with  $50\Omega$  to  $V_{CCO\_X} - 2V$ .

**Table 4G. LVPECL DC Characteristics,  $V_{CCO\_X}^1 = 2.5V \pm 5\%$ ,  $V_{EE} = 0V$ ,  $T_A = -40^\circ C$  to  $85^\circ C$**

Symbol	Parameter	Test Conditions	Minimum	Typical	Maximum	Units
$V_{OH}$	Output High Voltage <sup>2</sup>		$V_{CCO\_X} - 1.1$		$V_{CCO\_X} - 0.7$	V
$V_{OL}$	Output Low Voltage <sup>2</sup>		$V_{CCO\_X} - 2.0$		$V_{CCO\_X} - 1.5$	V
$V_{SWING}$	Peak-to-Peak Output Voltage Swing		0.6		1.0	V

NOTE 1:  $V_{CCO\_X}$  denotes  $V_{CCO\_A}$ ,  $V_{CCO\_B}$  and  $V_{CCO\_C}$ ,

NOTE 2: Outputs termination with  $50\Omega$  to  $V_{CCO\_X} - 2V$ .

**Table 5. Crystal Characteristics**

Parameter	Test Conditions	Minimum	Typical	Maximum	Units
Mode of Oscillation		Fundamental			
Frequency			25		MHz
Equivalent Series Resistance (ESR)				50	$\Omega$
Shunt Capacitance				7	pF
Load Capacitance ( $C_L$ )			12	18	pF

## AC Electrical Characteristics

**Table 6. AC Characteristics**,  $V_{CC} = V_{CC\_X} = V_{CCO\_X}^1 = 3.3V \pm 5\%$  or  $2.5V \pm 5\%$ , or  $V_{CC} = V_{CC\_X} = 3.3V \pm 5\%$ ,  $V_{CCO\_X}^1 = 2.5V \pm 5\%$ ,  $V_{EE} = 0V$ ,  $T_A = -40^\circ C$  to  $85^\circ C$

Symbol	Parameter		Test Conditions	Minimum	Typical	Maximum	Units
$f_{IN}$	Input Frequency		CLK_IN or XTAL		25		MHz
			CLK_IN		50		MHz
			CLK_IN		66.67		MHz
$f_{VCO}$	VCO Frequency				2500		MHz
$f_{jit}(\emptyset)$	LVPECL RMS Phase Jitter, Random <sup>2</sup>		100MHz, Integration Range: 12kHz – 20MHz		320	415	fs
			125MHz, Integration Range: 12kHz – 20MHz		210	270	fs
			125MHz, Integration Range: 10kHz – 1MHz		163	220	fs
			156.25MHz, Integration Range: 12kHz – 20MHz		199	260	fs
			156.25MHz, Integration Range: 10kHz – 1MHz		165	225	fs
			25MHz, Integration Range: 12kHz – 5MHz		245	415	fs
$f_{jit}(\emptyset)$	LVCMOS RMS Phase Jitter, Random <sup>2</sup>		125MHz, Integration Range: 12kHz – 20MHz		210	280	fs
			156.25MHz, Integration Range: 12kHz – 20MHz		204	265	fs
			100MHz, Integration Range: 12kHz – 20MHz		312	385	fs
$tsk(o)$	Output Skew; NOTE <sup>3, 4</sup>	LVPECL Outputs	Same Bank Outputs			51	ps
$t_R / t_F$	Output Rise/Fall Time	LVPECL Outputs	20% - 80%			500	ps
		LVCMOS Outputs	20% - 80%			700	ps
odc	Output Duty Cycle	LVPECL Outputs		45	50	55	%
		LVCMOS Outputs		45	50	55	%

NOTE 1: Electrical parameters are guaranteed over the specified ambient operating temperature range, which is established when the device is mounted in a test socket with maintained transverse airflow greater than 500 lpm. The device will meet specifications after thermal equilibrium has been reached under these conditions.

NOTE 2: Characterized using XTAL input.

NOTE 3: Defined as skew between outputs at the same supply voltage and with equal load conditions. Measured at the differential crosspoints.

NOTE 4: These parameters are guaranteed by characterization.

### Typical Phase Noise at 156.25MHz

Phase Noise 10.00dB/ Ref 0.000dBc/Hz

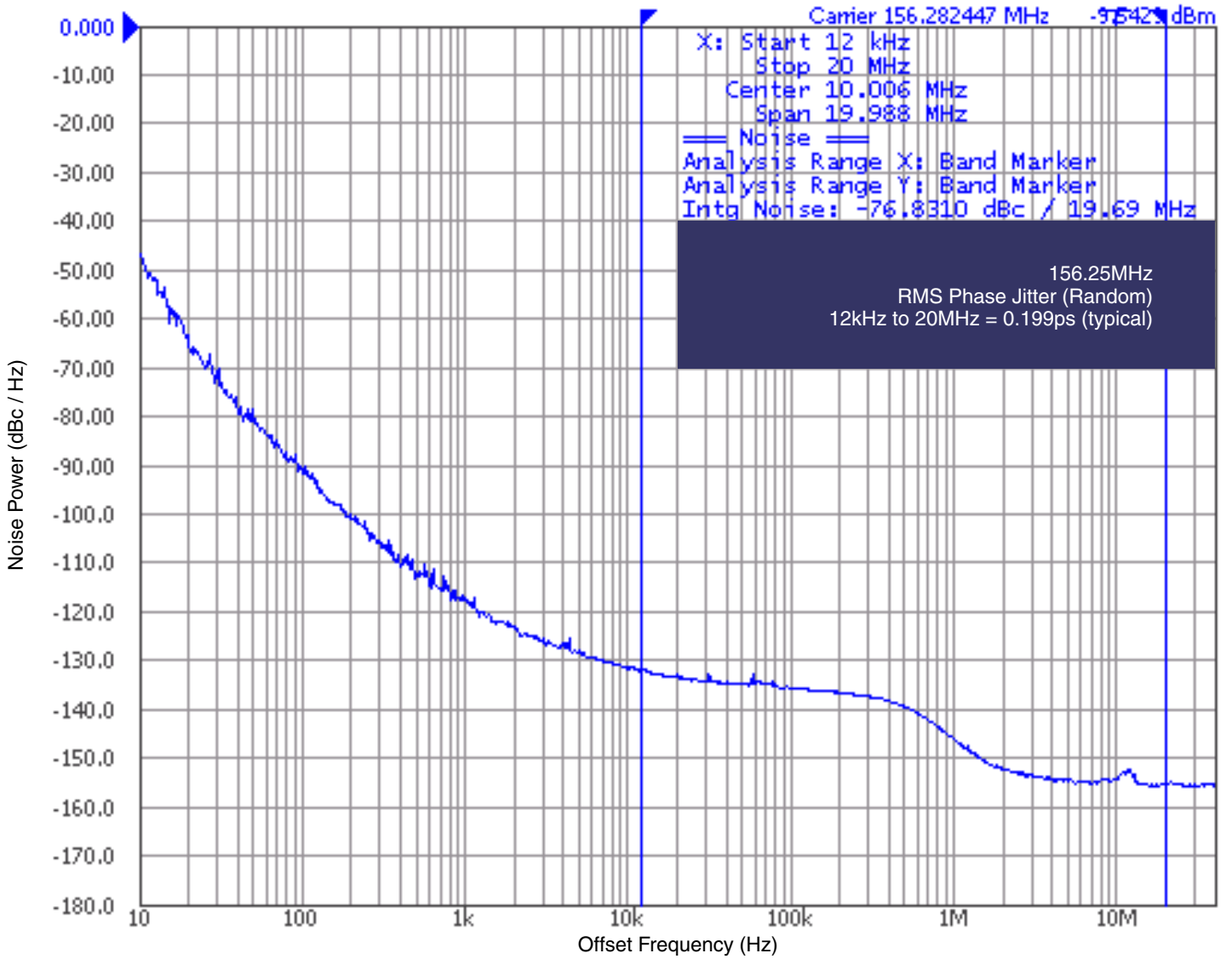

Parameter Measurement Information

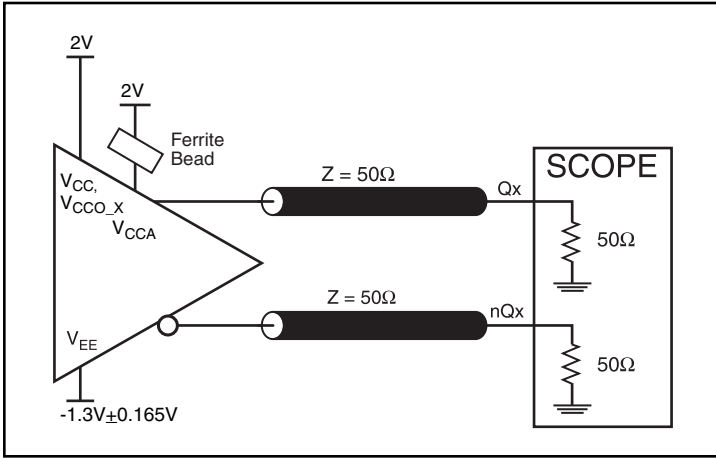

3.3V Core/3.3V QAx\_CMOS LVPECL Output Load Test Circuit

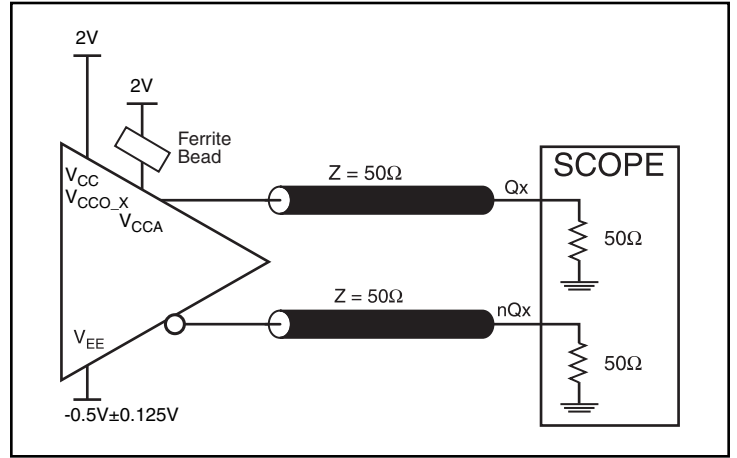

2.5V Core/2.5V QAx\_CMOS LVPECL Output Load Test Circuit

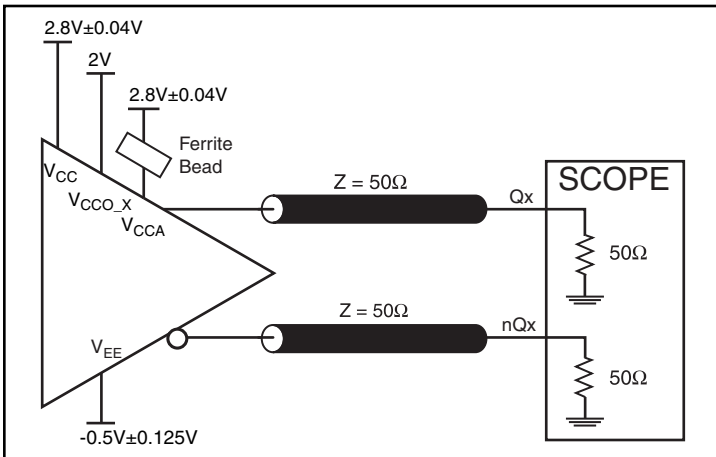

3.3V Core/2.5V QAx\_CMOS LVPECL Output Load Test Circuit

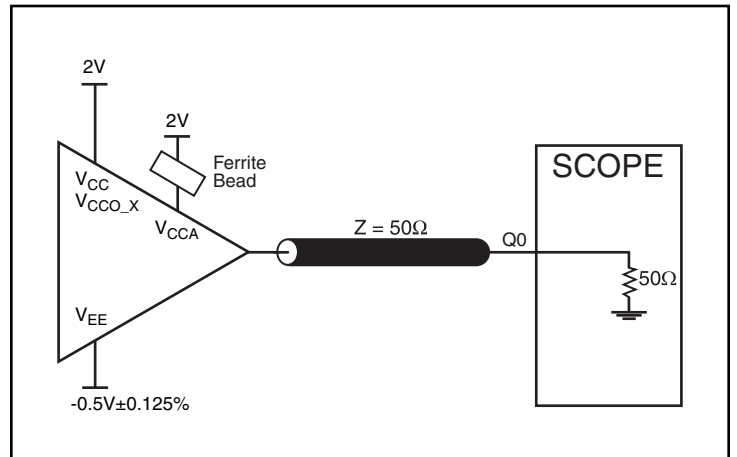

2.5V/2.5V QAx\_CMOS Output Load Test Circuit

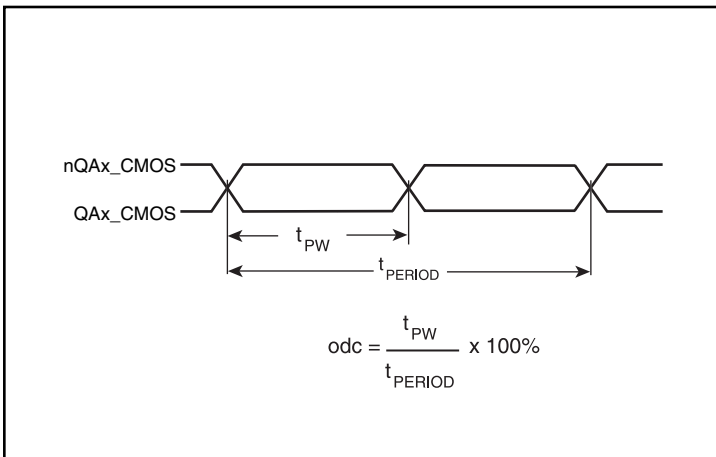

LVCMOS Output Duty Cycle/Pulse Width/Period

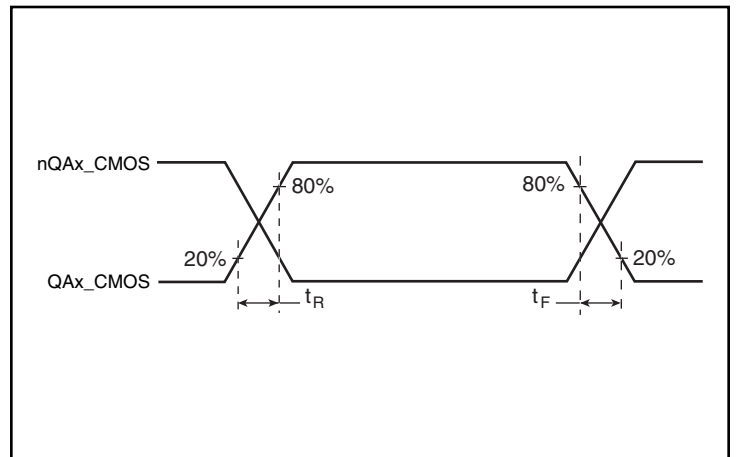

Output Rise/Fall Time

Parameter Measurement Information, continued

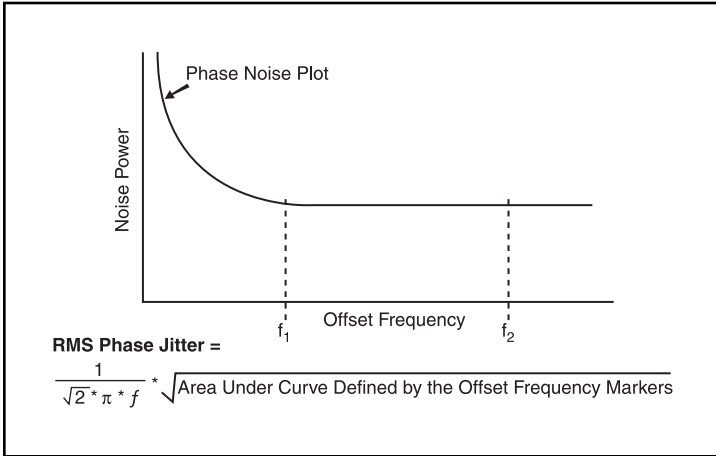

RMS Phase Jitter

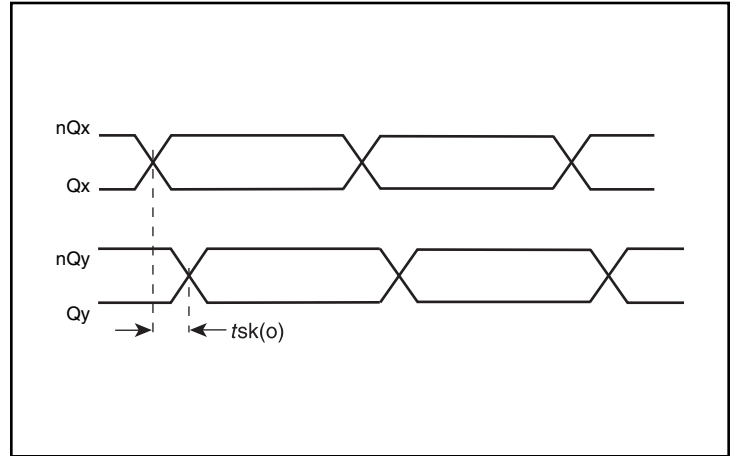

Output Skew

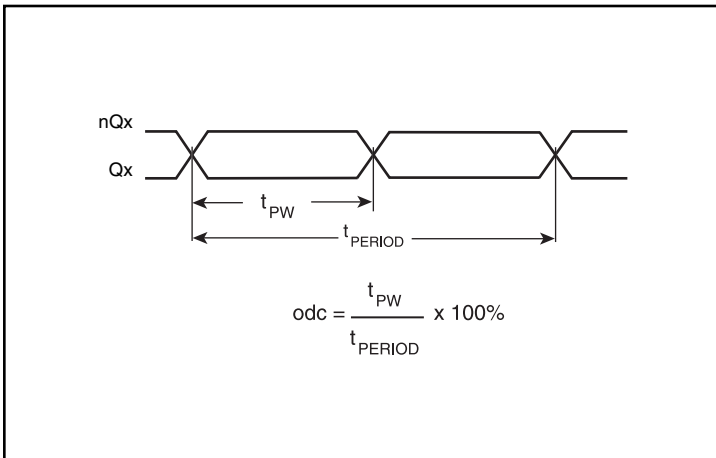

Differential Output Duty Cycle

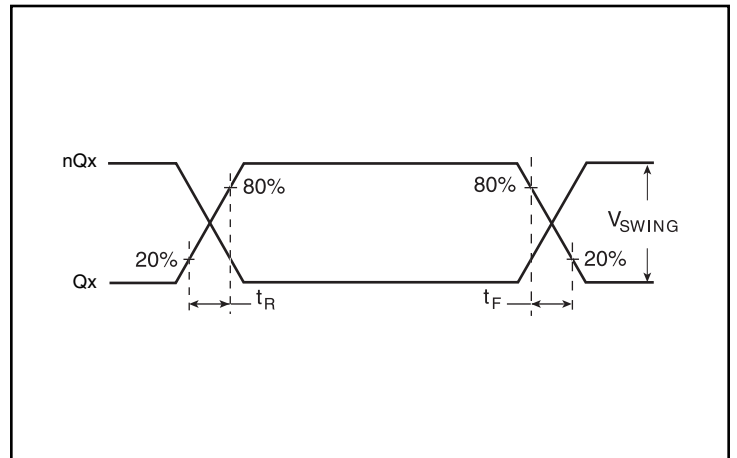

LVPECL Output Rise/Fall Time

## Applications Information

### Recommendations for Unused Input and Output Pins

#### Inputs:

##### Crystal Inputs

For applications not requiring the use of the crystal oscillator input, both XTAL\_IN and XTAL\_OUT can be left floating. Though not required, but for additional protection, a 1k $\Omega$  resistor can be tied from XTAL\_IN to ground.

##### CLK Input

For applications not requiring the use of a clock input, it can be left floating. Though not required, but for additional protection, a 1k $\Omega$  resistor can be tied from the CLK input to ground.

##### LVC MOS Control Pins

All control pins have internal pullup or pulldown resistors; additional resistance is not required but can be added for additional protection. A 1k $\Omega$  resistor can be used.

#### Outputs:

##### LVPECL Outputs

All unused LVPECL output pairs can be left floating. We recommend that there is no trace attached. Both sides of the differential output pair should either be left floating or terminated.

##### LVC MOS Outputs

All unused LVC MOS outputs can be left floating. There should be no trace attached.

### VFQFN EPAD Thermal Release Path

In order to maximize both the removal of heat from the package and the electrical performance, a land pattern must be incorporated on the Printed Circuit Board (PCB) within the footprint of the package corresponding to the exposed metal pad or exposed heat slug on the package, as shown in *Figure 1*. The solderable area on the PCB, as defined by the solder mask, should be at least the same size/shape as the exposed pad/slug area on the package to maximize the thermal/electrical performance. Sufficient clearance should be designed on the PCB between the outer edges of the land pattern and the inner edges of pad pattern for the leads to avoid any shorts.

While the land pattern on the PCB provides a means of heat transfer and electrical grounding from the package to the board through a solder joint, thermal vias are necessary to effectively conduct from the surface of the PCB to the ground plane(s). The land pattern must be connected to ground through these vias. The vias act as “heat pipes”. The number of vias (i.e. “heat pipes”) are application specific

and dependent upon the package power dissipation as well as electrical conductivity requirements. Thus, thermal and electrical analysis and/or testing are recommended to determine the minimum number needed. Maximum thermal and electrical performance is achieved when an array of vias is incorporated in the land pattern. It is recommended to use as many vias connected to ground as possible. It is also recommended that the via diameter should be 12 to 13mils (0.30 to 0.33mm) with 1oz copper via barrel plating. This is desirable to avoid any solder wicking inside the via during the soldering process which may result in voids in solder between the exposed pad/slug and the thermal land. Precautions should be taken to eliminate any solder voids between the exposed heat slug and the land pattern. Note: These recommendations are to be used as a guideline only. For further information, please refer to the Application Note on the Surface Mount Assembly of Amkor’s Thermally/Electrically Enhance Lead frame Base Package, Amkor Technology.

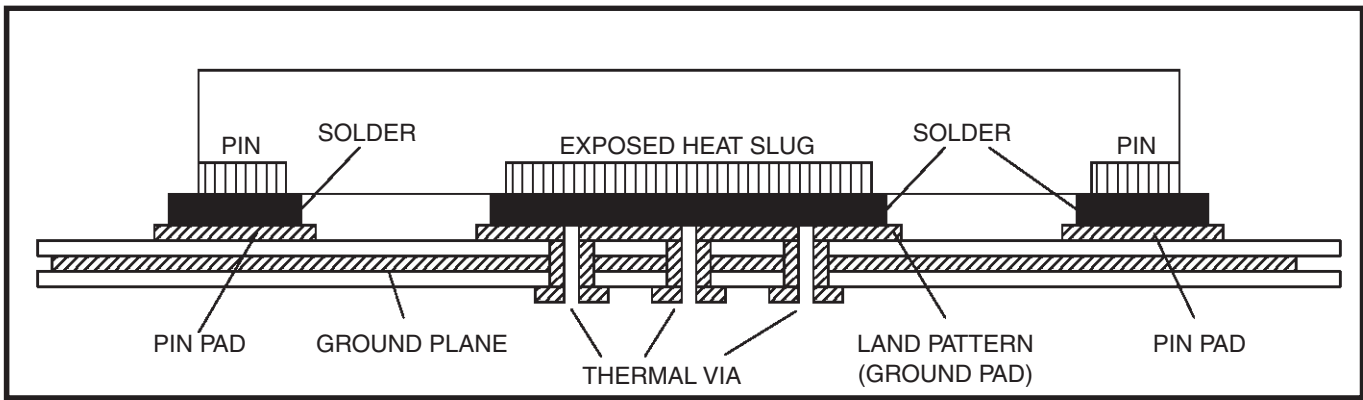

**Figure 1. P.C. Assembly for Exposed Pad Thermal Release Path – Side View (drawing not to scale)**

## Overdriving the XTAL Interface

The XTAL\_IN input can be overdriven by an LVCMOS driver or by one side of a differential driver through an AC coupling capacitor. The XTAL\_OUT pin can be left floating. The amplitude of the input signal should be between 500mV and 1.8V and the slew rate should not be less than 0.2V/ns. For 3.3V LVCMOS inputs, the amplitude must be reduced from full swing to at least half the swing in order to prevent signal interference with the power rail and to reduce internal noise. *Figure 2A* shows an example of the interface diagram for a high speed 3.3V LVCMOS driver. This configuration requires that the sum of the output impedance of the driver ( $R_o$ ) and the series resistance ( $R_s$ ) equals the transmission line impedance. In addition, matched termination at the crystal input will attenuate the signal in half. This

can be done in one of two ways. First,  $R_1$  and  $R_2$  in parallel should equal the transmission line impedance. For most 50Ω applications,  $R_1$  and  $R_2$  can be 100Ω. This can also be accomplished by removing  $R_1$  and changing  $R_2$  to 50Ω. The values of the resistors can be increased to reduce the loading for a slower and weaker LVCMOS driver. *Figure 2B* shows an example of the interface diagram for an LVPECL driver. This is a standard LVPECL termination with one side of the driver feeding the XTAL\_IN input. It is recommended that all components in the schematics be placed in the layout. Though some components might not be used, they can be utilized for debugging purposes. The datasheet specifications are characterized and guaranteed by using a quartz crystal as the input.

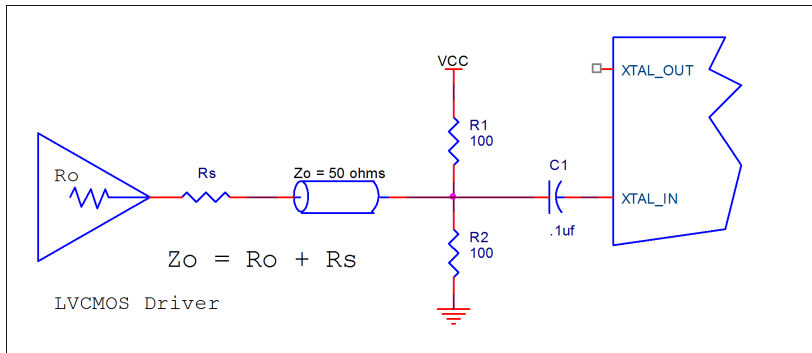

Figure 2A. General Diagram for LVCMOS Driver to XTAL Input Interface

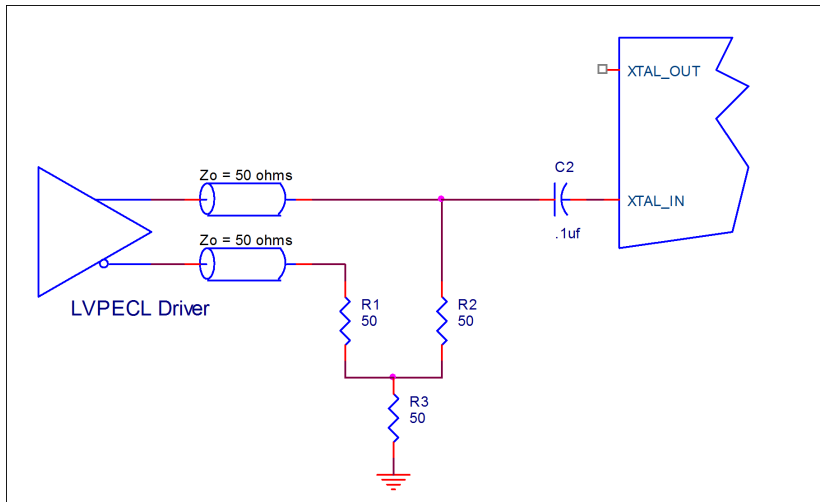

Figure 2B. General Diagram for LVPECL Driver to XTAL Input Interface

### Termination for 3.3V LVPECL Outputs

The clock layout topology shown below is a typical termination for LVPECL outputs. The two different layouts mentioned are recommended only as guidelines.

The differential outputs are low impedance follower outputs that generate ECL/LVPECL compatible outputs. Therefore, terminating resistors (DC current path to ground) or current sources must be used for functionality. These outputs are designed to drive 50Ω

transmission lines. Matched impedance techniques should be used to maximize operating frequency and minimize signal distortion.

*Figure 3A* shows a layout that is recommended only as a guideline. Other suitable clock layouts may exist and it would be recommended that the board designers simulate to guarantee compatibility across all printed circuit and clock component process variations.

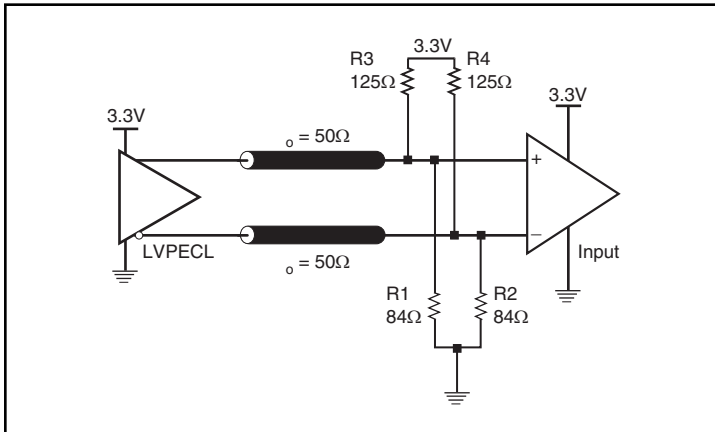

**Figure 3A. 3.3V LVPECL Output Termination**

### Termination for 2.5V LVPECL Outputs

Figure 4A and Figure 4B show examples of termination for 2.5V LVPECL driver. These terminations are equivalent to terminating  $50\Omega$  to  $V_{CC0} - 2V$ . For  $V_{CC0} = 2.5V$ , the  $V_{CC0} - 2V$  is very close to ground

level. The R3 in Figure 4B can be eliminated and the termination is shown in Figure 4C.

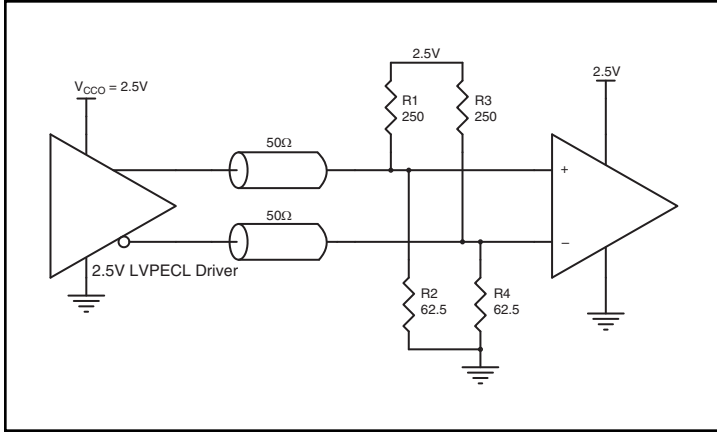

Figure 4A. 2.5V LVPECL Driver Termination Example

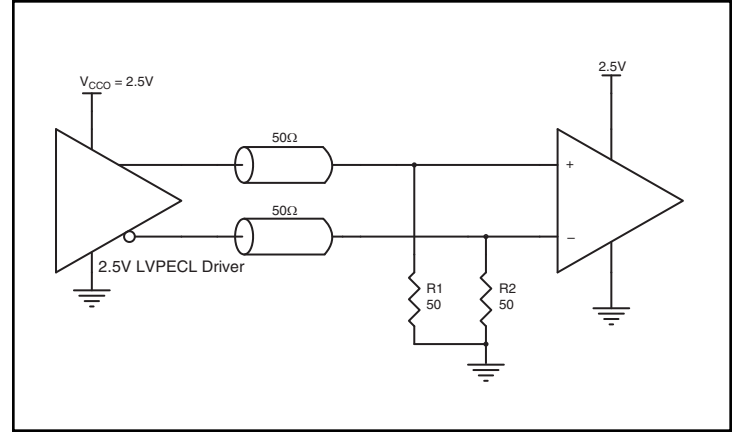

Figure 4C. 2.5V LVPECL Driver Termination Example

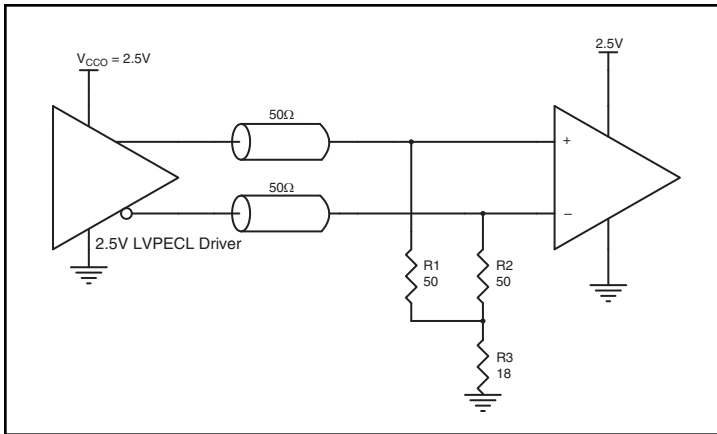

Figure 4B. 2.5V LVPECL Driver Termination Example

## Schematic Example

*Figure 5* (next page) is an 8T49N012 application example schematic. The schematic focuses on functional connections and is not configuration specific. Refer to the pin description and functional tables in the datasheet to ensure that the logic control inputs are properly set.

In this example the device is operated at all  $V_{CC}$  power pins = 3.3V. The Bank A outputs are configured for LVCMOS by pulling SE high. Three different examples of LVPECL terminations are shown for the outputs to demonstrate less common termination options.

Crystal layout is very important to minimize capacitive coupling between the crystal pads and leads and other metal in the circuit board. Capacitive coupling to other conductors has two adverse effects. The first is that it reduces the oscillator frequency, leaving less tuning margin. Second, noise on power planes and logic transitions on signal traces can pull the phase of voltages on the XTAL\_IN and XTAL\_OUT pins of the oscillator.

Using a crystal on the top layer as an example, void all signal and power layers under the crystal, XTAL\_IN, XTAL\_OUT and the input pins of the 8T49N012 between the top layer and the ground plane for the 8T49N012. If the ground plane for the 8T49N012 is the first layer under the crystal and the parasitic capacity of the traces and pads is excessive, then void enough power and signal planes to minimize the

coupling capacity to the first ground plane. Ensure that the ground under the crystal is the same ground as used for the tuning caps and the oscillator.

As with any high speed analog circuitry, the power supply pins are vulnerable to random noise. To achieve optimum jitter performance, power supply isolation is required. The 8T49N012 provides separate power supply pins to isolate any high switching noise from coupling into the internal PLL.

In order to achieve the best possible filtering, it is recommended that the placement of the filter components be on the device side of the PCB as close to the power pins as possible. The 0.1 $\mu$ F capacitors in each power pin filter must be placed on the device side. If space is limited, the other components can be on the opposite side of the PCB. Power supply filter recommendations are a general guideline to be used for reducing external noise from coupling into the devices.

The  $V_{CC}$  and  $V_{CCO}$  LC filters start to attenuate noise at approximately 10kHz. If a specific frequency noise component is known, such as switching power supplies frequencies, it is recommended that component values be adjusted and if required, additional filtering be added. Additionally, good general design practices for power plane voltage stability suggests adding bulk capacitance in the local area of all devices.

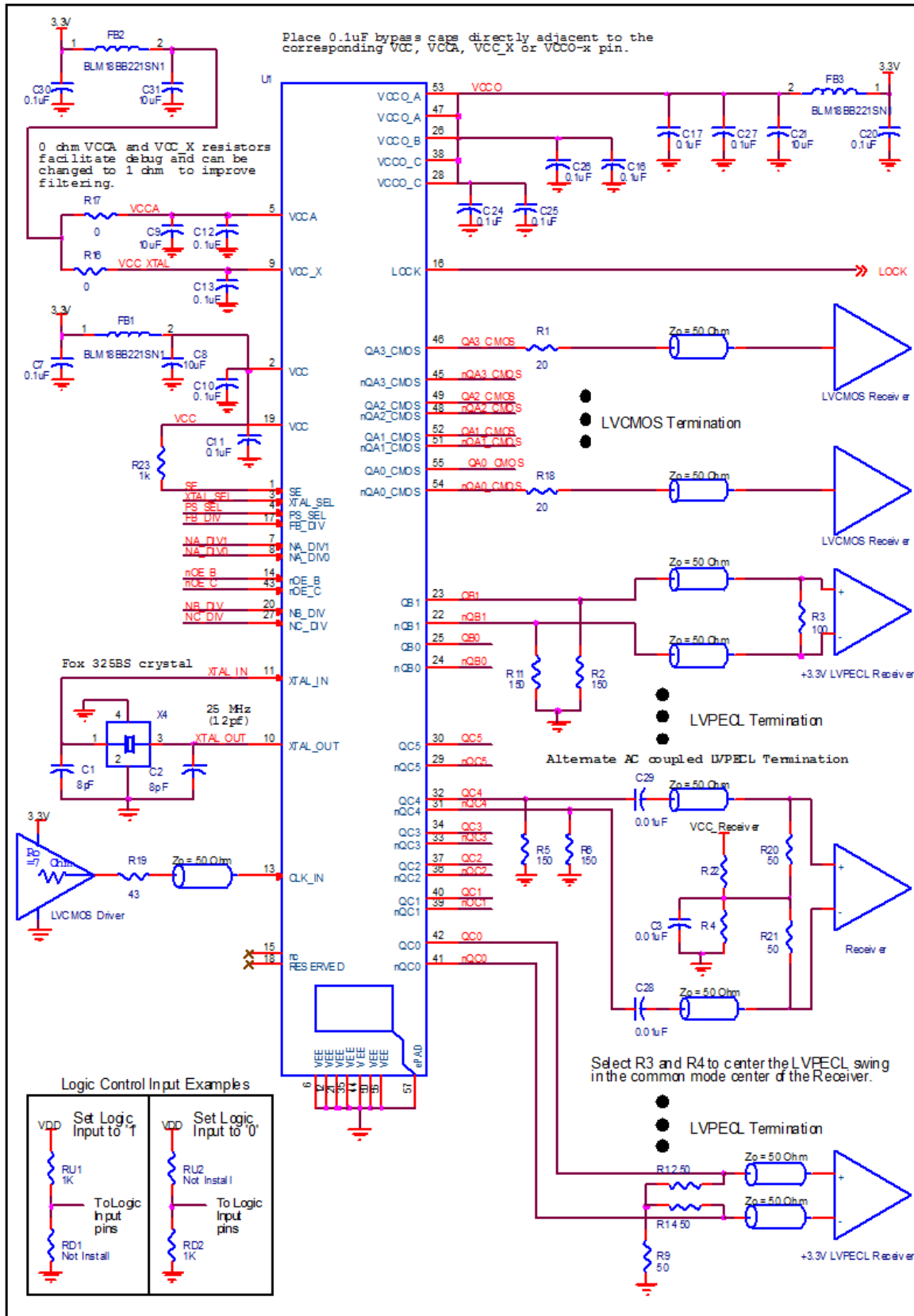

Figure 5. 8T49N012 Schematic Example

## Power Considerations

This section provides information on power dissipation and junction temperature for the 8T49N012I. Equations and example calculations are also provided.

### 1. Power Dissipation

The total power dissipation for the 8T49N012 is the sum of the core power plus the output power dissipated due to the loading. The following is the power dissipation for  $V_{CC} = 3.3V + 5\% = 3.465V$ , which gives worst case results.

$I_{EE} = 344mA$  with QA Bank in LVCMOS mode is the worst case scenario.

- Power (core)<sub>MAX</sub> =  $V_{CC\_MAX} * I_{EE} = 3.465V * 0.345A = \mathbf{1.195W}$
- Power (LVPECL)<sub>MAX</sub> = **31mW** per output
- Total Power (LVPECL)<sub>MAX</sub> =  $31mW * 8 = \mathbf{0.248W}$

#### LVCMOS Dynamic Power Dissipation

- Dynamic Power at 312.5MHz:  
 $P = C_{PD} * Freq * (V_{DDO})^2 = 6.5pF * 312.5MHz * (3.465V)^2$   
 $P = 0.024W$  per output  
 Total Power (CPD) =  $0.024W * 8 = 0.195W$

Total Power Dissipation

- **Total Power**  
 = Power (core) + Total Power (LVPECL) + Total Power (CPD)  
 =  $1.195W + 0.248W + 0.195W$   
 = **1.638W**

### 2. Junction Temperature

Junction temperature,  $T_J$ , is the temperature at the junction of the bond wire and bond pad directly affects the reliability of the device. The maximum recommended junction temperature is 125°C. Limiting the internal transistor junction temperature,  $T_J$ , to 125°C ensures that the bond wire and bond pad temperature remains below 125°C.

The equation for  $T_J$  is as follows:  $T_J = \theta_{JA} * Pd_{total} + T_A$

$T_J$  = Junction Temperature

$\theta_{JA}$  = Junction-to-Ambient Thermal Resistance

$Pd_{total}$  = Total Device Power Dissipation (example calculation is in section 1 above)

$T_A$  = Ambient Temperature

In order to calculate junction temperature, the appropriate junction-to-ambient thermal resistance  $\theta_{JA}$  must be used. Assuming no air flow and a multi-layer board, the appropriate value is 23.1 per [Table 7](#) below.

°C/W per [Table 6](#) below.

Therefore,  $T_J$  for an ambient temperature of 85°C with all outputs switching is:

$$85°C + 1.638W * 23.1°C/W = 122.8°C. \text{ This is below the limit of } 125°C.$$

This calculation is only an example.  $T_J$  will obviously vary depending on the number of loaded outputs, supply voltage, air flow and the type of board (multi-layer).

**Table 7. Thermal Resistance  $\theta_{JA}$  for 56-Lead VFQFN, Forced Convection**

$\theta_{JA}$ vs. Air Flow			
Meters per Second	0	1	2.5
Multi-Layer PCB, JEDEC Standard Test Boards	23.1°C/W	20.2°C/W	18.6°C/W

### 3. Calculations and Equations.

The purpose of this section is to calculate the power dissipation for the LVPECL output pair.

The LVPECL output driver circuit and termination are shown in *Figure 6*.

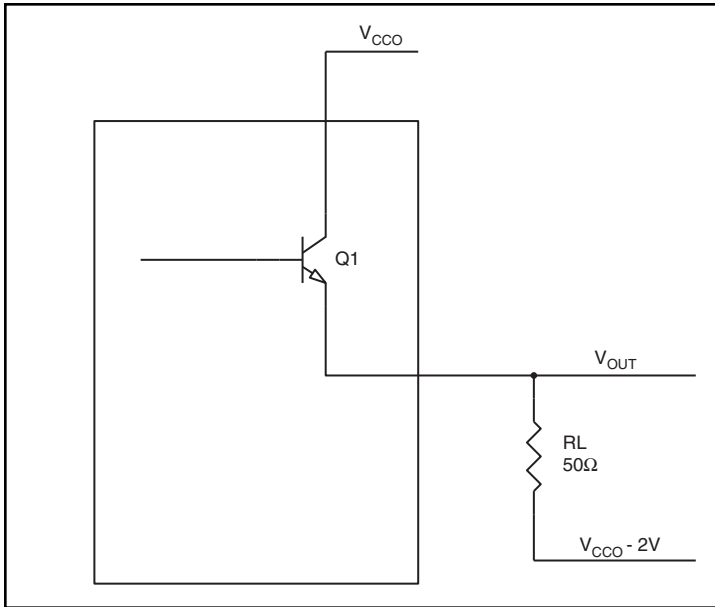

**Figure 6. LVPECL Driver Circuit and Termination**

To calculate power dissipation per output pair due to loading, use the following equations which assume a 50Ω load, and a termination voltage of  $V_{CCO} - 2V$ .

- For logic high,  $V_{OUT} = V_{OH\_MAX} = V_{CCO\_MAX} - 0.7V$   
 $(V_{CCO\_MAX} - V_{OH\_MAX}) = 0.7V$
- For logic low,  $V_{OUT} = V_{OL\_MAX} = V_{CCO\_MAX} - 1.6V$   
 $(V_{CCO\_MAX} - V_{OL\_MAX}) = 1.6V$

$Pd\_H$  is power dissipation when the output drives high.

$Pd\_L$  is the power dissipation when the output drives low.

$$Pd\_H = [(V_{OH\_MAX} - (V_{CCO\_MAX} - 2V))/R_L] * (V_{CCO\_MAX} - V_{OH\_MAX}) = [(2V - (V_{CCO\_MAX} - V_{OH\_MAX}))/R_L] * (V_{CCO\_MAX} - V_{OH\_MAX}) = [(2V - 0.7V)/50\Omega] * 0.7V = \mathbf{18.2mW}$$

$$Pd\_L = [(V_{OH\_MAX} - (V_{CCO\_MAX} - 2V))/R_L] * (V_{CCO\_MAX} - V_{OL\_MAX}) = [(2V - (V_{CCO\_MAX} - V_{OL\_MAX}))/R_L] * (V_{CCO\_MAX} - V_{OL\_MAX}) = [(2V - 1.6V)/50\Omega] * 1.6V = \mathbf{12.8mW}$$

$$\text{Total Power Dissipation per output pair} = Pd\_H + Pd\_L = \mathbf{31.00mW}$$

## Reliability Information

**Table 8.  $\theta_{JA}$  vs. Air Flow Table for a 56-Lead VFQFN**

$\theta_{JA}$ vs. Air Flow			
Meters per Second	0	1	2.5
Multi-Layer PCB, JEDEC Standard Test Boards	23.1°C/W	20.2°C/W	18.6°C/W

## Transistor Count

The transistor count for 8T49N012 is 176,638

# 56-Lead VFQFN Package Outline and Package Dimension

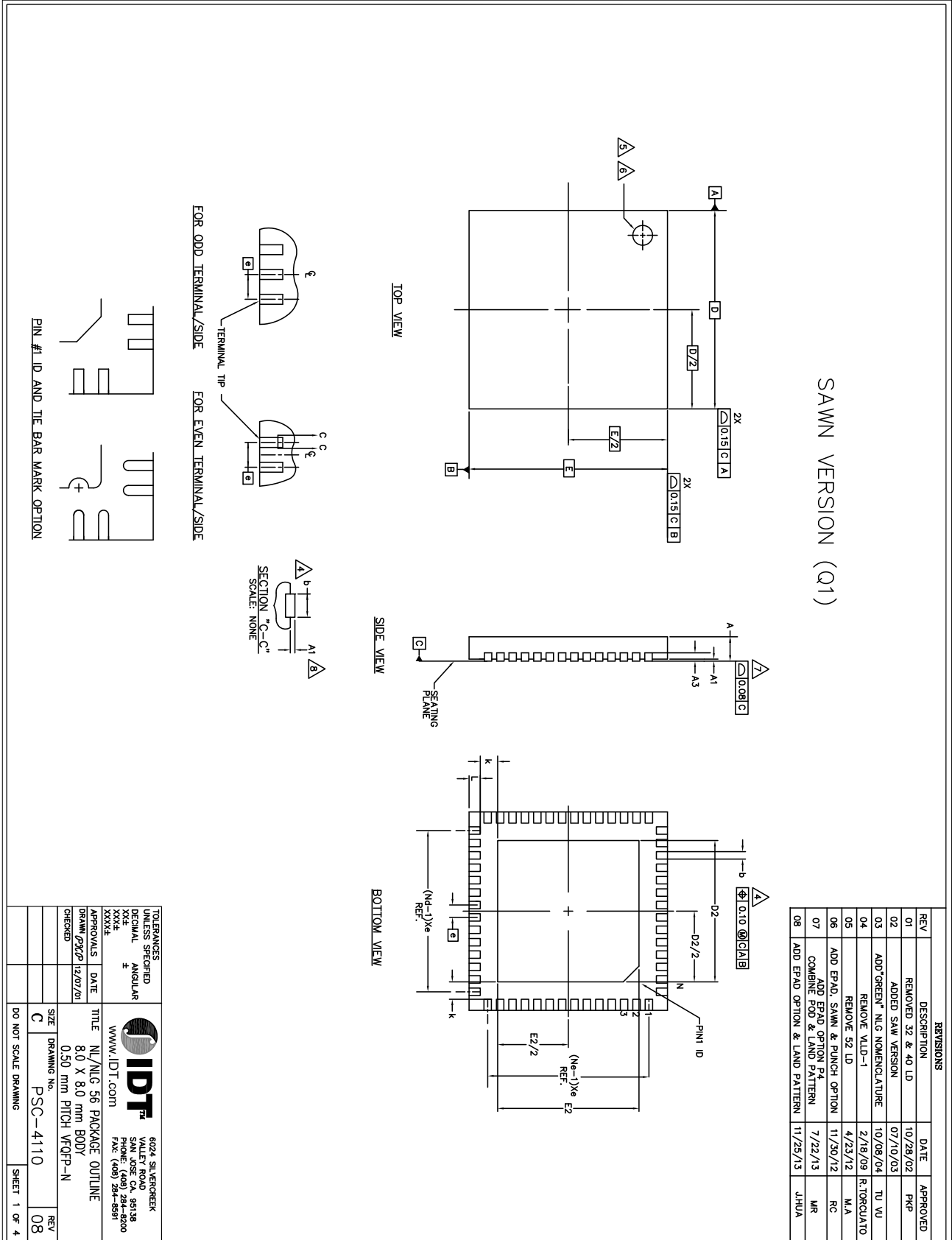

56-Lead VFQFN Package Outline and Package Dimensions, continued

EPAD OPTION

	P2		
	MIN	NOM	MAX
E2	6.45	6.60	6.75
D2	6.45	6.60	6.75

COMMON DIMENSION

DIMENSION	DIMENSION		
	MIN.	NOM.	MAX.
$\frac{5}{8}$	0.50	BSC	
$\frac{6}{9}$	56		2
N	14		2
Nd	14		2
Ne	14		2
L	0.30	0.40	0.50
b	0.18	0.25	0.30
D2	SEE EPAD OPTION		
E2	SEE EPAD OPTION		
A	0.80	0.9	1.00
A1	0.00	0.02	0.05
A3	0.20 REF.		
D	8.00 BSC		
E	8.00 BSC		
$\theta$	12°		
k	0.20	—	

- NOTES:
1. DIMENSIONING & TOLERANCING CONFORM TO ASME Y14.5M - 1994.
  2. N IS THE NUMBER OF TERMINALS.  
Nd IS THE NUMBER OF TERMINALS IN X-DIRECTION &  
Ne IS THE NUMBER OF TERMINALS IN Y-DIRECTION.  
3. ALL DIMENSIONS ARE IN MILLIMETERS.
  3. ALL DIMENSIONS ARE IN MILLIMETERS.  
4. DIMENSION b APPLIES TO PLATED TERMINAL AND IS MEASURED BETWEEN 0.20 AND 0.30mm FROM TERMINAL TIP.
  5. THE PIN #1 IDENTIFIER MUST EXIST ON THE TOP SURFACE OF THE PACKAGE BY USING INDENTATION MARK OR OTHER FEATURE OF PACKAGE BODY.
  6. EXACT SHAPE AND SIZE OF THIS FEATURE IS OPTIONAL.
  7. APPLIED TO EXPOSED PAD AND TERMINALS. EXCLUDE EMBEDDED PART OF EXPOSED PAD FROM MEASURING.
  8. APPLIED ONLY FOR TERMINALS.
  9. NOT AN ACTUAL IO.

REV	DESCRIPTION	DATE	APPROVED
01	REVISED 32 & 40 LD	10/28/02	PNP
02	ADDED SAW VERSION	07/10/03	TU WU
03	ADD/CHANGED NICK NICKELCATHODE	10/08/04	RTORIGLATO
04	REMOVE ALD-1	3/18/08	M.A
05	REMOVE 32 LD	4/23/12	MC
06	ADD EPAD SAW & FINISH OPTION	11/20/12	MC
07	CHANGE BODY & LEAD PATTERN	7/22/13	MB
08	ADD EPAD OPTION & LEAD PATTERN	11/28/13	JHAA

TOLERANCES UNLESS SPECIFIED DECIMAL ANGULAR XXXX ± WWW.IDT.COM		 6024 SILVERCREEK VALLEY ROAD SUITE 2000 FOLSOM, CA 95630 PHONE (480) 764-1000 FAX (480) 764-1001	
APPROVALS	DATE	TITLE	SIZE
DRAWN (P2/2P)	12/07/01	NL/NLG 56 PACKAGE OUTLINE	C
DESIGNED		0.50 mm PITCH VFQFN-N	PSC-4110
			DO NOT SCALE DRAWING
			SHEET 3 OF 4

56-Lead VFQFN Package Outline and Package Dimensions, continued

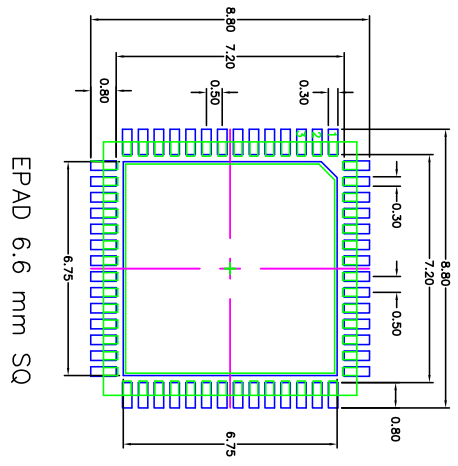

EPAD 6.6 mm SQ

REVISIONS			
REV	DESCRIPTION	DATE	APPROVED
01	REMOVED 32 & 40 LD	10/28/02	PKP
02	ADDED SAW VERSION	07/10/03	
03	ADD 'GREEN' N/G NOMENCLATURE	10/08/04	TU VU
04	REMOVE VLD-1	2/18/09	R.TORQUATO
05	REMOVE 52 LD	4/23/12	M.A
06	ADD EPAD, SAWM & PUNCH OPTION	7/22/13	RC
07	COMBINE FLD & LAND PATTERN	11/20/13	MR
08	ADD EPAD OPTION & LAND PATTERN	11/25/13	JHUA

- NOTES:
1. ALL DIMENSIONS ARE IN mm. ANGLES IN DEGREES.
  2. TOP DOWN VIEW, AS VIEWED ON PCB.
  3. COMPONENT OUTLINE SHOW FOR REFERENCE IN GREEN.
  4. LAND PATTERN IN BLUE. NSMD PATTERN ASSUMED.
  5. LAND PATTERN RECOMMENDATION PER IPC-7351B GENERIC REQUIREMENT FOR SURFACE MOUNT DESIGN AND LAND PATTERN.

TOLERANCES UNLESS SPECIFIED				6024 SILVERCREEK VALLEY ROAD SAN JOSE CA, 95138 PHONE: (408) 284-8200 FAX: (408) 284-8591	
DECIMAL	ANGULAR			WWW.IDT.COM	
XXXX	°			TITLE N/G N/G 56 PACKAGE OUTLINE 8.0 X 8.0 mm BODY 0.50 mm PITCH VFQFN-N	
APPROVALS	DATE	SIZE	DRAWING No.	REV	
DRAWN: g2p	12/07/01	C	PSC-4110	08	
CHECKED		DO NOT SCALE DRAWING		SHEET	4 OF 4

## Ordering Information

**Table 9. Ordering Information**

<b>Part/Order Number</b>	<b>Marking</b>	<b>Package</b>	<b>Shipping Packaging</b>	<b>Temperature</b>
8T49N012NLGI	IDT8T49N012NLGI	"Lead-Free" 56-Lead VFQFN	Tray	-40°C to 85°C
8T49N012NLGI8	IDT8T49N012NLGI	"Lead-Free" 56-Lead VFQFN	Tape & Reel	-40°C to 85°C



## IMPORTANT NOTICE AND DISCLAIMER

RENESAS ELECTRONICS CORPORATION AND ITS SUBSIDIARIES (“RENESAS”) PROVIDES TECHNICAL SPECIFICATIONS AND RELIABILITY DATA (INCLUDING DATASHEETS), DESIGN RESOURCES (INCLUDING REFERENCE DESIGNS), APPLICATION OR OTHER DESIGN ADVICE, WEB TOOLS, SAFETY INFORMATION, AND OTHER RESOURCES “AS IS” AND WITH ALL FAULTS, AND DISCLAIMS ALL WARRANTIES, EXPRESS OR IMPLIED, INCLUDING, WITHOUT LIMITATION, ANY IMPLIED WARRANTIES OF MERCHANTABILITY, FITNESS FOR A PARTICULAR PURPOSE, OR NON-INFRINGEMENT OF THIRD-PARTY INTELLECTUAL PROPERTY RIGHTS.

These resources are intended for developers who are designing with Renesas products. You are solely responsible for (1) selecting the appropriate products for your application, (2) designing, validating, and testing your application, and (3) ensuring your application meets applicable standards, and any other safety, security, or other requirements. These resources are subject to change without notice. Renesas grants you permission to use these resources only to develop an application that uses Renesas products. Other reproduction or use of these resources is strictly prohibited. No license is granted to any other Renesas intellectual property or to any third-party intellectual property. Renesas disclaims responsibility for, and you will fully indemnify Renesas and its representatives against, any claims, damages, costs, losses, or liabilities arising from your use of these resources. Renesas' products are provided only subject to Renesas' Terms and Conditions of Sale or other applicable terms agreed to in writing. No use of any Renesas resources expands or otherwise alters any applicable warranties or warranty disclaimers for these products.

(Disclaimer Rev.1.01 Jan 2024)

### Corporate Headquarters

TOYOSU FORESIA, 3-2-24 Toyosu,  
Koto-ku, Tokyo 135-0061, Japan  
[www.renesas.com](http://www.renesas.com)

### Trademarks

Renesas and the Renesas logo are trademarks of Renesas Electronics Corporation. All trademarks and registered trademarks are the property of their respective owners.

### Contact Information

For further information on a product, technology, the most up-to-date version of a document, or your nearest sales office, please visit [www.renesas.com/contact-us/](http://www.renesas.com/contact-us/).

## Looking for pricing, stock, or lifecycle information?

Click below to explore more details on WIN SOURCE:

-  [View 8T49N012NLGI on WIN SOURCE](#)
-  [Renesas Electronics America](#) Information

## Optimize Your Supply Chain with WIN SOURCE Solutions

-  Global Sourcing Solution
-  Obsolete Management
-  Cost Control Management
-  Shortage Management
-  Alternative Solution
-  Excess Inventory Management