



## General Description

The ICS8543 is a low skew, high performance 1-to-4 Differential-to-LVDS Clock Fanout Buffer. Utilizing Low Voltage Differential Signaling (LVDS) the ICS8543 provides a low power, low noise, solution for distributing clock signals over controlled impedances of 100Ω. The ICS8543 has two selectable clock inputs. The CLK, nCLK pair can accept most standard differential input levels. The PCLK, nPCLK pair can accept LVPECL, CML, or SSTL input levels. The clock enable is internally synchronized to eliminate runt pulses on the outputs during asynchronous assertion/deassertion of the clock enable pin.

Guaranteed output and part-to-part skew characteristics make the ICS8543 ideal for those applications demanding well defined performance and repeatability.

## Features

- Four differential LVDS output pairs
- Selectable differential CLK, nCLK or LVPECL clock inputs
- CLK, nCLK pair can accept the following differential input levels: LVPECL, LVDS, LVHSTL, SSTL, HCSL
- PCLK, nPCLK pair can accept the following differential input levels: LVPECL, CML, SSTL
- Maximum output frequency: 800MHz
- Translates any single-ended input signals to LVDS levels with resistor bias on nCLK input
- Additive phase jitter, RMS: 0.164ps (typical)
- Output skew: 40ps (maximum)
- Part-to-part skew: 500ps (maximum)
- Propagation delay: 2.6ns (maximum)
- Full 3.3V supply mode
- 0°C to 70°C ambient operating temperature
- Available in both standard (RoHS 5) and lead-free (RoHS 6) packages

## Block Diagram

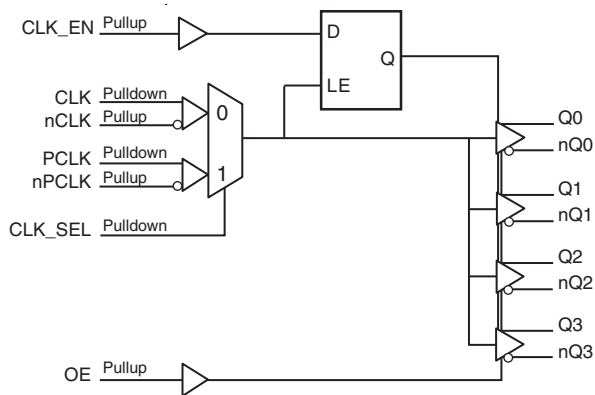

## Pin Assignment

GND	1	20	Q0
CLK_EN	2	19	nQ0
CLK_SEL	3	18	V <sub>DD</sub>
CLK	4	17	Q1
nCLK	5	16	nQ1
PCLK	6	15	Q2
nPCLK	7	14	nQ2
OE	8	13	GND
GND	9	12	Q3
V <sub>DD</sub>	10	11	nQ3

**ICS8543**

**20-Lead TSSOP**

**6.5mm x 4.4mm x 0.925mm**

**package body**

**G Package**

**Top View**

**Table 1. Pin Descriptions**

Number	Name	Type		Description
1, 9, 13	GND	Power		Power supply ground.
2	CLK_EN	Input	Pullup	Synchronizing clock enable. When HIGH, clock outputs follows clock input. When LOW, Qx outputs are forced low, nQx outputs are forced high. LVCMOS / LVTTTL interface levels.
3	CLK_SEL	Input	Pulldown	Clock select input. When HIGH, selects PCLK, nPCLK inputs. When LOW, selects CLK, nCLK inputs. LVCMOS / LVTTTL interface levels.
4	CLK	Input	Pulldown	Non-inverting differential clock input.
5	nCLK	Input	Pullup	Inverting differential clock input.
6	PCLK	Input	Pulldown	Non-inverting differential LVPECL clock input.
7	nPCLK	Input	Pullup	Inverting differential LVPECL clock input.
8	OE	Input	Pullup	Output enable. Controls enabling and disabling of outputs Q[0:3], nQ[0:3]. LVCMOS/LVTTTL interface levels.
10, 18	V <sub>DD</sub>	Power		Positive supply pins.
11, 12	nQ3, Q3	Output		Differential output pair. LVDS interface levels.
14, 15	nQ2, Q2	Output		Differential output pair. LVDS interface levels.
16, 17	nQ1, Q1	Output		Differential output pair. LVDS interface levels.
19, 20	nQ0, Q0	Output		Differential output pair. LVDS interface levels.

NOTE: Pullup and Pulldown refer to internal input resistors. See Table 2, *Pin Characteristics*, for typical values.

**Table 2. Pin Characteristics**

Symbol	Parameter	Test Conditions	Minimum	Typical	Maximum	Units
C <sub>IN</sub>	Input Capacitance			4		pF
R <sub>PULLUP</sub>	Input Pullup Resistor			51		kΩ
R <sub>PULLDOWN</sub>	Input Pulldown Resistor			51		kΩ

## Function Tables

Table 3A. Control Input Function Table

Inputs				Outputs	
OE	CLK_EN	CLK_SEL	Selected Source	Q[0:3]	nQ[0:3]
0	X	X		Hi-Z	Hi-Z
1	0	0	CLK, nCLK	Disabled; Low	Disabled; High
1	0	1	PCLK, nPCLK	Disabled; Low	Disabled; High
1	1	0	CLK, nCLK	Enabled	Enabled
1	1	1	PCLK, nPCLK	Enabled	Enabled

After CLK\_EN switches, the clock outputs are disabled or enabled following a rising and falling input clock edge as shown in Figure 1. In the active mode, the state of the outputs are a function of the CLK/nCLK and PCLK/nPCLK inputs as described in Table 3B.

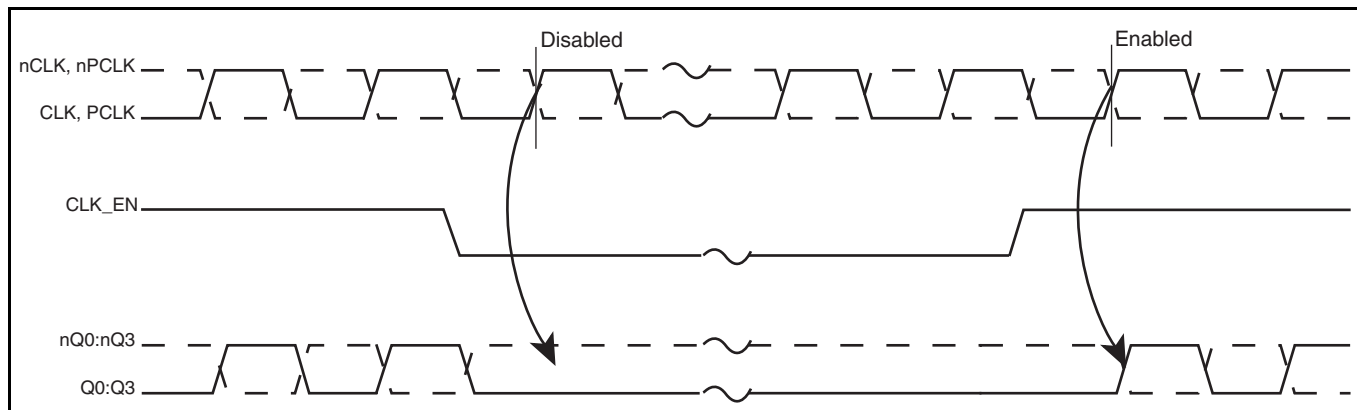

Figure 1. CLK\_EN Timing Diagram

Table 3B. Clock Input Function Table

Inputs		Outputs		Input to Output Mode	Polarity
CLK or PCLK	nCLK or nPCLK	Q[0:3]	nQ[0:3]		
0	1	LOW	HIGH	Differential to Differential	Non-Inverting
1	0	HIGH	LOW	Differential to Differential	Non-Inverting
0	Biased; NOTE 1	LOW	HIGH	Single-Ended to Differential	Non-Inverting
1	Biased; NOTE 1	HIGH	LOW	Single-Ended to Differential	Non-Inverting
Biased; NOTE 1	0	HIGH	LOW	Single-Ended to Differential	Inverting
Biased; NOTE 1	1	LOW	HIGH	Single-Ended to Differential	Inverting

NOTE 1: Please refer to the Application Information section, *Wiring the Differential Input to Accept Single-Ended Levels*.

## Absolute Maximum Ratings

NOTE: Stresses beyond those listed under *Absolute Maximum Ratings* may cause permanent damage to the device. These ratings are stress specifications only. Functional operation of product at these conditions or any conditions beyond those listed in the *DC Characteristics* or *AC Characteristics* is not implied. Exposure to absolute maximum rating conditions for extended periods may affect product reliability.

Item	Rating
Supply Voltage, $V_{DD}$	4.6V
Inputs, $V_I$	-0.5V to $V_{DD} + 0.5V$
Outputs, $I_O$ Continuous Current Surge Current	10mA 15mA
Package Thermal Impedance, $\theta_{JA}$	73.2°C/W (0 lfpm)
Storage Temperature, $T_{STG}$	-65°C to 150°C

## DC Electrical Characteristics

**Table 4A. Power Supply DC Characteristics,  $V_{DD} = 3.3V \pm 5\%$ ,  $T_A = 0^\circ C$  to  $70^\circ C$**

Symbol	Parameter	Test Conditions	Minimum	Typical	Maximum	Units
$V_{DD}$	Positive Supply Voltage		3.135	3.3	3.465	V
$I_{DD}$	Power Supply Current				50	mA

**Table 4B. LVCMOS/LVTTL DC Characteristics,  $V_{DD} = 3.3V \pm 5\%$ ,  $T_A = 0^\circ C$  to  $70^\circ C$**

Symbol	Parameter	Test Conditions	Minimum	Typical	Maximum	Units
$V_{IH}$	Input High Voltage		2		3.765	V
$V_{IL}$	Input Low Voltage				0.8	V
$I_{IH}$	Input High Current	OE, CLK_EN	$V_{DD} = V_{IN} = 3.465V$		5	$\mu A$
		CLK_SEL	$V_{DD} = V_{IN} = 3.465V$		150	$\mu A$
$I_{IL}$	Input Low Current	OE, CLK_EN	$V_{DD} = 3.465V, V_{IN} = 0V$	-150		$\mu A$
		CLK_SEL	$V_{DD} = 3.465V, V_{IN} = 0V$	-5		$\mu A$

**Table 4C. Differential DC Characteristics,  $V_{DD} = 3.3V \pm 5\%$ ,  $T_A = 0^\circ C$  to  $70^\circ C$** 

Symbol	Parameter	Test Conditions	Minimum	Typical	Maximum	Units
$I_{IH}$	Input High Current	CLK	$V_{DD} = V_{IN} = 3.465V$		150	$\mu A$
		nCLK	$V_{DD} = V_{IN} = 3.465V$		5	$\mu A$
$I_{IL}$	Input Low Current	CLK	$V_{DD} = 3.465V, V_{IN} = 0V$	-5		$\mu A$
		nCLK	$V_{DD} = 3.465V, V_{IN} = 0V$	-150		$\mu A$
$V_{PP}$	Peak-to-Peak Voltage; NOTE 1		0.15		1.3	V
$V_{CMR}$	Common Mode Input Voltage; NOTE 1, 2		0.5		$V_{DD} - 0.85$	V

NOTE 1:  $V_{IL}$  should not be less than -0.3V.

NOTE 2: Common mode input voltage is defined as  $V_{IH}$ .

**Table 4D. LVPECL DC Characteristics,  $V_{DD} = 3.3V \pm 5\%$ ,  $T_A = 0^\circ C$  to  $70^\circ C$** 

Symbol	Parameter	Test Conditions	Minimum	Typical	Maximum	Units
$I_{IH}$	Input High Current	PCLK	$V_{DD} = V_{IN} = 3.465V$		150	$\mu A$
		nPCLK	$V_{DD} = V_{IN} = 3.465V$		5	$\mu A$
$I_{IL}$	Input Low Current	PCLK	$V_{DD} = 3.465V, V_{IN} = 0V$	-5		$\mu A$
		nPCLK	$V_{DD} = 3.465V, V_{IN} = 0V$	-150		$\mu A$
$V_{PP}$	Peak-to-Peak Voltage		0.3		1.0	V
$V_{CMR}$	Common Mode Input Voltage; NOTE 1		1.5		$V_{DD}$	V

NOTE 1: Common mode input voltage is defined as  $V_{IH}$ .

**Table 4E. LVDS DC Characteristics,  $V_{DD} = 3.3V \pm 5\%$ ,  $T_A = 0^\circ C$  to  $70^\circ C$** 

Symbol	Parameter	Test Conditions	Minimum	Typical	Maximum	Units
$V_{OD}$	Differential Output Voltage		200	280	360	mV
$\Delta V_{OD}$	$V_{OD}$ Magnitude Change			0	40	mV
$V_{OS}$	Offset Voltage		1.125	1.25	1.375	V
$\Delta V_{OS}$	$V_{OS}$ Magnitude Change			5	25	mV
$I_{Oz}$	High Impedance Leakage		-10		+10	$\mu A$
$I_{OFF}$	Power Off Leakage		-20	$\pm 1$	+20	$\mu A$
$I_{OSD}$	Differential Output Short Circuit Current			-3.5	-5	mA
$I_{OS}$	Output Short Circuit Current			-3.5	-5	mA
$V_{OH}$	Output Voltage High			1.34	1.6	V
$V_{OL}$	Output Voltage Low		0.9	1.06		V

## AC Electrical Characteristics

**Table 5. AC Characteristics,  $V_{DD} = 3.3V \pm 5\%$ ,  $T_A = 0^\circ C$  to  $70^\circ C$**

Symbol	Parameter	Test Conditions	Minimum	Typical	Maximum	Units
$f_{MAX}$	Maximum Output Frequency				800	MHz
$t_{PD}$	Propagation Delay; NOTE 1	$f \leq 800MHz$	1.7		2.6	ns
$f_{jit}$	Buffer Additive Phase Jitter, RMS; refer to Additive Phase Jitter Section	153.6MHz, Integration Range: 12kHz – 20MHz		0.164		ps
$t_{sk(o)}$	Output Skew; NOTE 2, 4				40	ps
$t_{sk(pp)}$	Part-to-Part Skew; NOTE 3, 4				500	ps
$t_R / t_F$	Output Rise/Fall Time	20% to 80% @ 50MHz	150		350	ps
odc	Output Duty Cycle	odc	45	50	55	%

NOTE: Electrical parameters are guaranteed over the specified ambient operating temperature range, which is established when the device is mounted in a test socket with maintained transverse airflow greater than 500 lfm. The device will meet specifications after thermal equilibrium has been reached under these conditions.

NOTE: All parameters measured at 500MHz unless noted otherwise.

NOTE 1: Measured from the differential input crossing point to the differential output crossing point.

NOTE 2: Defined as skew between outputs at the same supply voltage and with equal load conditions. Measured at the differential output cross points.

NOTE 3: Defined as skew between outputs on different devices operating at the same supply voltage, same frequency, same temperature and with equal load conditions. Using the same type of inputs on each device, the outputs are measured at the differential cross points.

NOTE 4: This parameter is defined in accordance with JEDEC Standard 65.

## Additive Phase Jitter

The spectral purity in a band at a specific offset from the fundamental compared to the power of the fundamental is called the ***dBc Phase Noise***. This value is normally expressed using a Phase noise plot and is most often the specified plot in many applications. Phase noise is defined as the ratio of the noise power present in a 1Hz band at a specified offset from the fundamental frequency to the power value of the fundamental. This ratio is expressed in decibels (dBm) or a ratio

of the power in the 1Hz band to the power in the fundamental. When the required offset is specified, the phase noise is called a ***dBc*** value, which simply means dBm at a specified offset from the fundamental. By investigating jitter in the frequency domain, we get a better understanding of its effects on the desired application over the entire time record of the signal. It is mathematically possible to calculate an expected bit error rate given a phase noise plot.

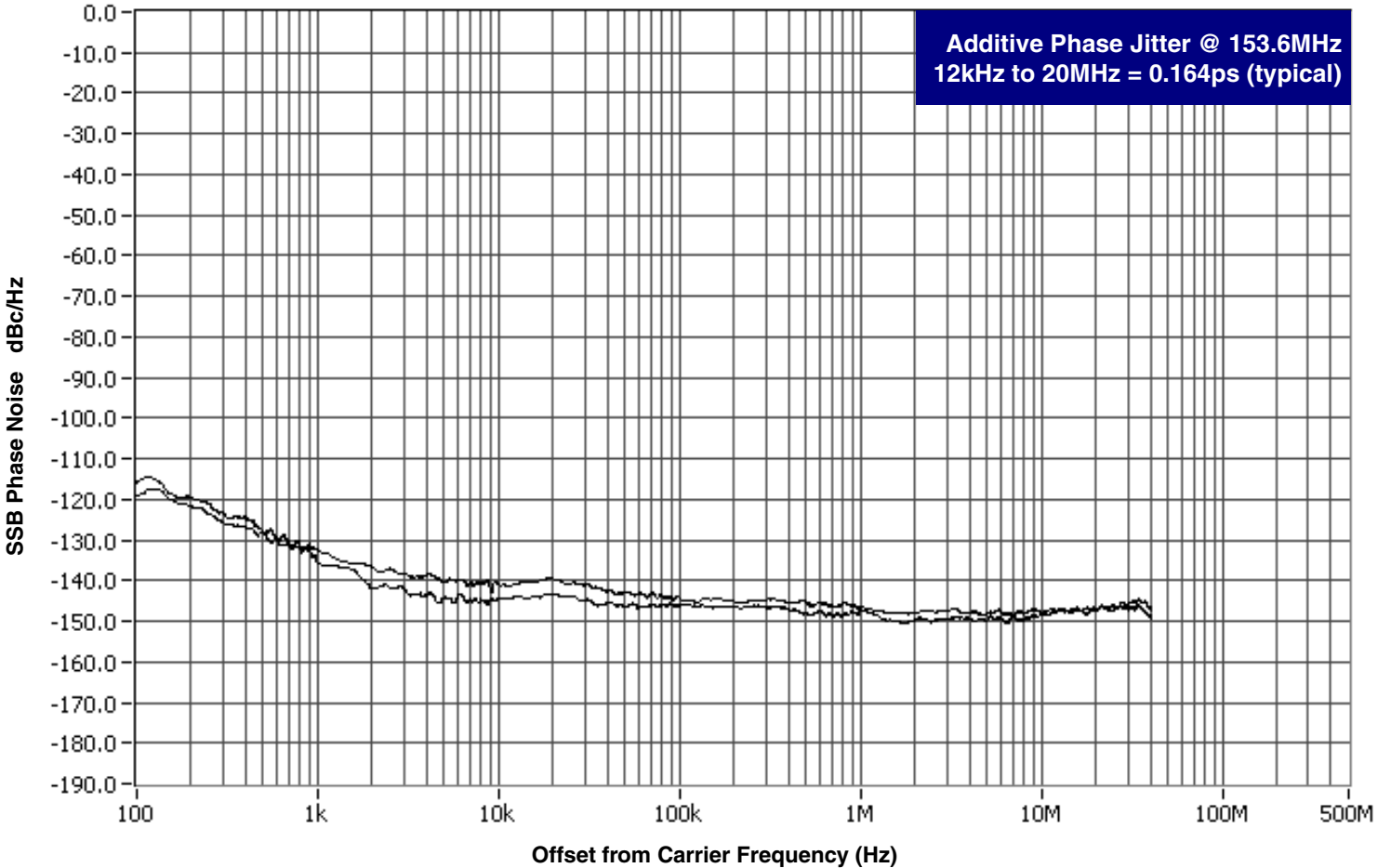

As with most timing specifications, phase noise measurements has issues relating to the limitations of the equipment. Often the noise floor of the equipment is higher than the noise floor of the device. This

is illustrated above. The device meets the noise floor of what is shown, but can actually be lower. The phase noise is dependent on the input source and measurement equipment.

## Parameter Measurement Information

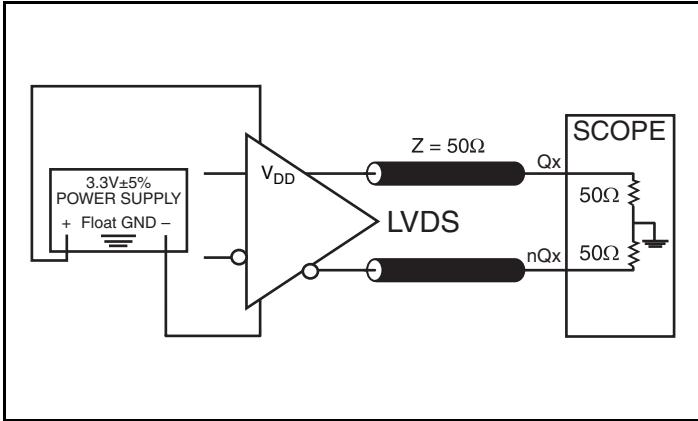

3.3V LVDS Output Load AC Test Circuit

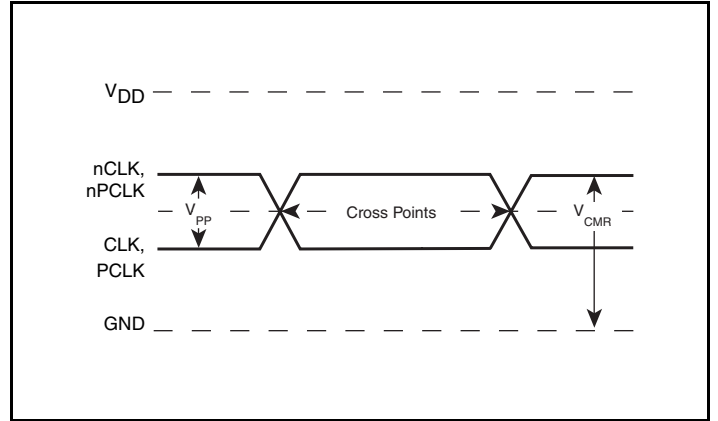

Differential Input Level

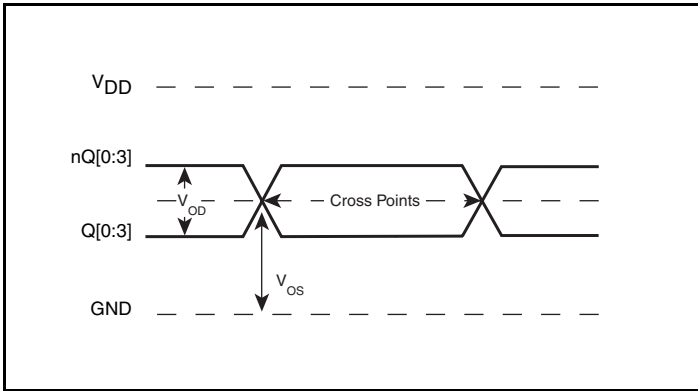

Differential Output Level

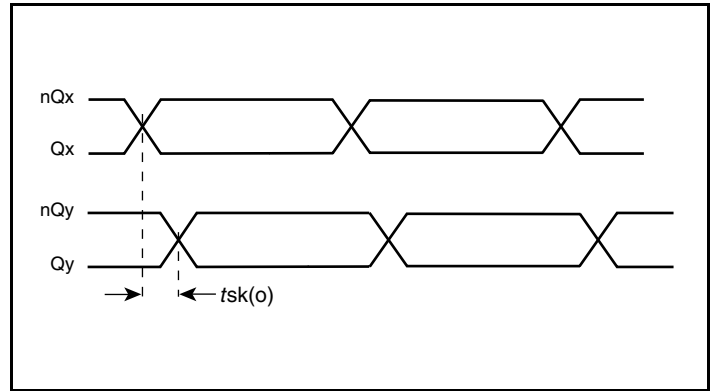

Output Skew

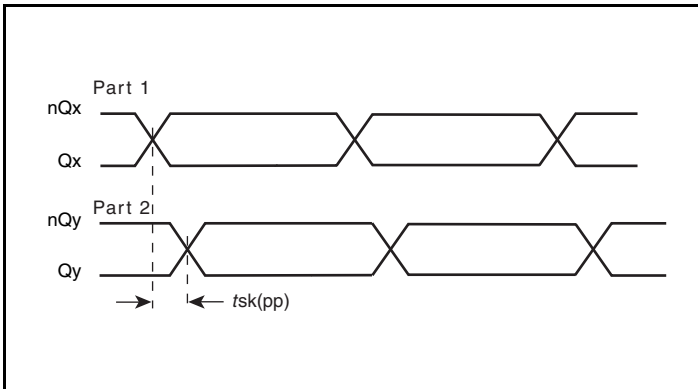

Part-to-Part Skew

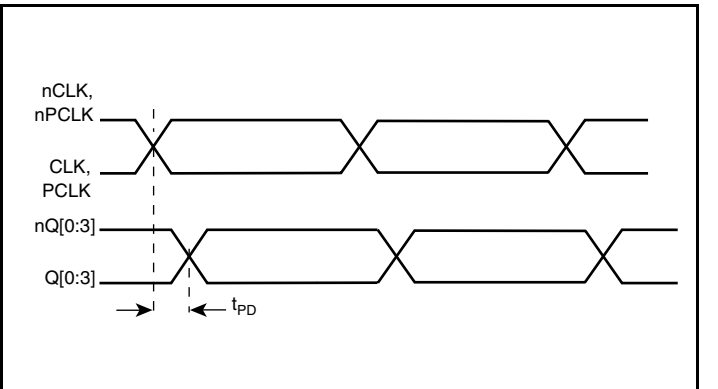

Propagation Delay

Parameter Measurement Information, continued

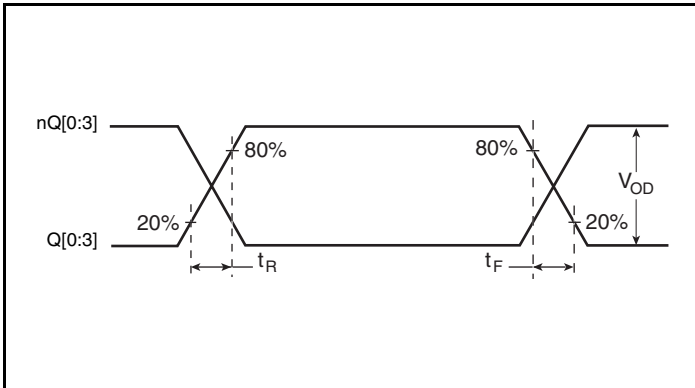

Output Rise/Fall Time

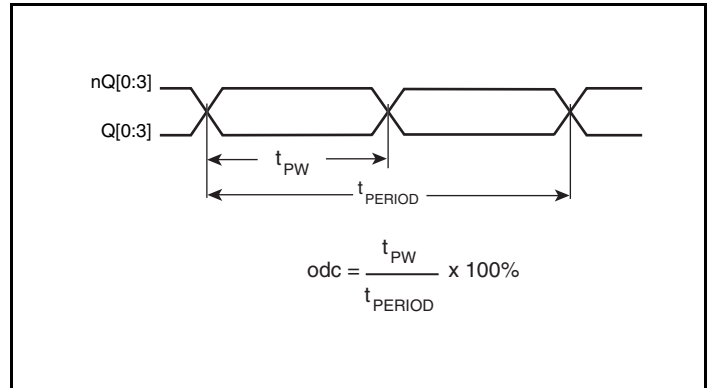

Output Duty Cycle/Pulse Width/Period

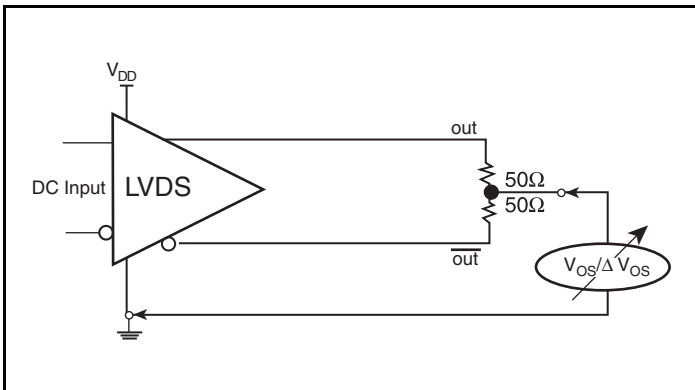

Offset Voltage Setup

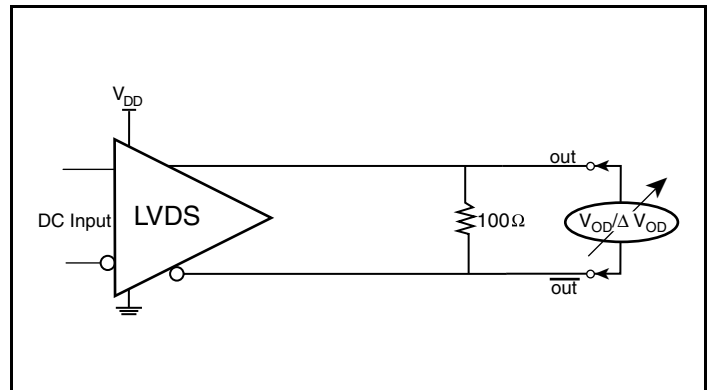

Differential Output Voltage Setup

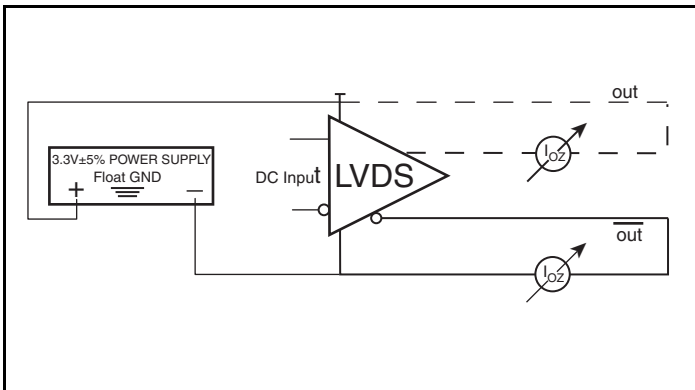

High Impedance Leakage Current Setup

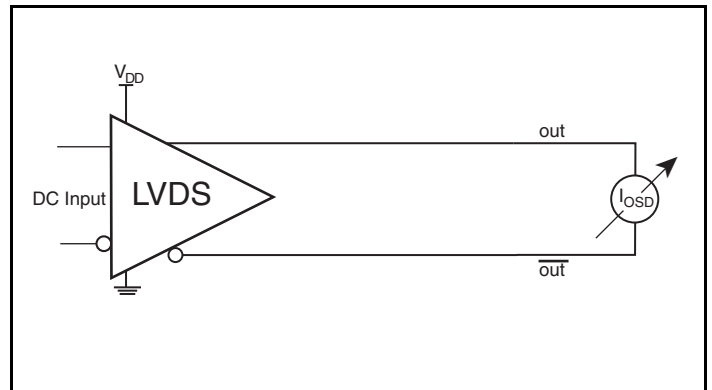

Differential Output Short Circuit Setup

## Parameter Measurement Information, continued

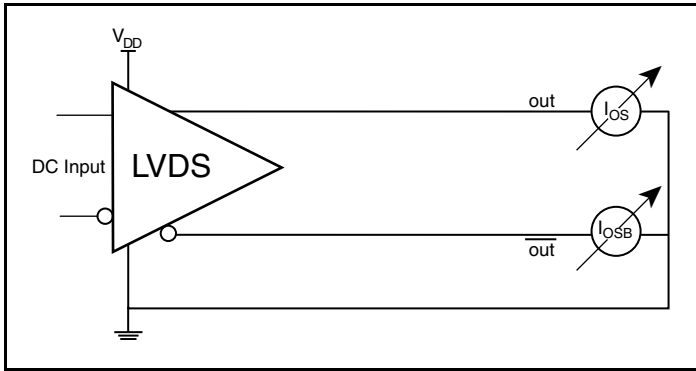

Output Short Circuit Current Setup

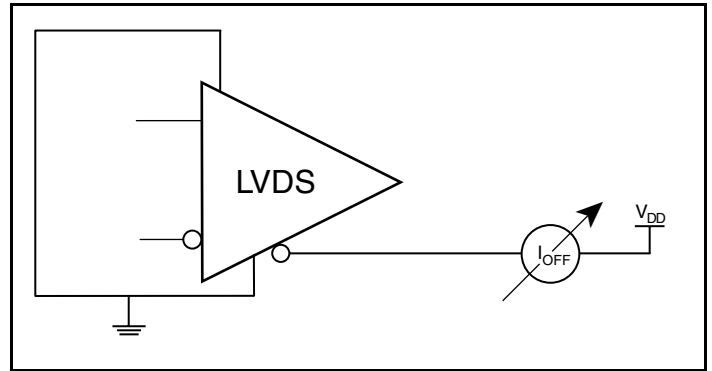

Power Off Leakage Setup

## Applications Information

### Wiring the Differential Input to Accept Single-Ended Levels

Figure 2 shows how a differential input can be wired to accept single ended levels. The reference voltage  $V_{REF} = V_{CC}/2$  is generated by the bias resistors R1 and R2. The bypass capacitor (C1) is used to help filter noise on the DC bias. This bias circuit should be located as close to the input pin as possible. The ratio of R1 and R2 might need to be adjusted to position the  $V_{REF}$  in the center of the input voltage swing. For example, if the input clock swing is 2.5V and  $V_{DD} = 3.3V$ , R1 and R2 value should be adjusted to set  $V_{REF}$  at 1.25V. The values below are for when both the single ended swing and  $V_{DD}$  are at the same voltage. This configuration requires that the sum of the output impedance of the driver ( $R_o$ ) and the series resistance ( $R_s$ ) equals the transmission line impedance. In addition, matched termination at the input will attenuate the signal in half. This can be done in one of two ways. First, R3 and R4 in parallel should equal the transmission

line impedance. For most 50Ω applications, R3 and R4 can be 100Ω. The values of the resistors can be increased to reduce the loading for slower and weaker LVCMOS driver. When using single-ended signaling, the noise rejection benefits of differential signaling are reduced. Even though the differential input can handle full rail LVCMOS signaling, it is recommended that the amplitude be reduced. The datasheet specifies a lower differential amplitude, however this only applies to differential signals. For single-ended applications, the swing can be larger, however  $V_{IL}$  cannot be less than -0.3V and  $V_{IH}$  cannot be more than  $V_{DD} + 0.3V$ . Though some of the recommended components might not be used, the pads should be placed in the layout. They can be utilized for debugging purposes. The datasheet specifications are characterized and guaranteed by using a differential signal.

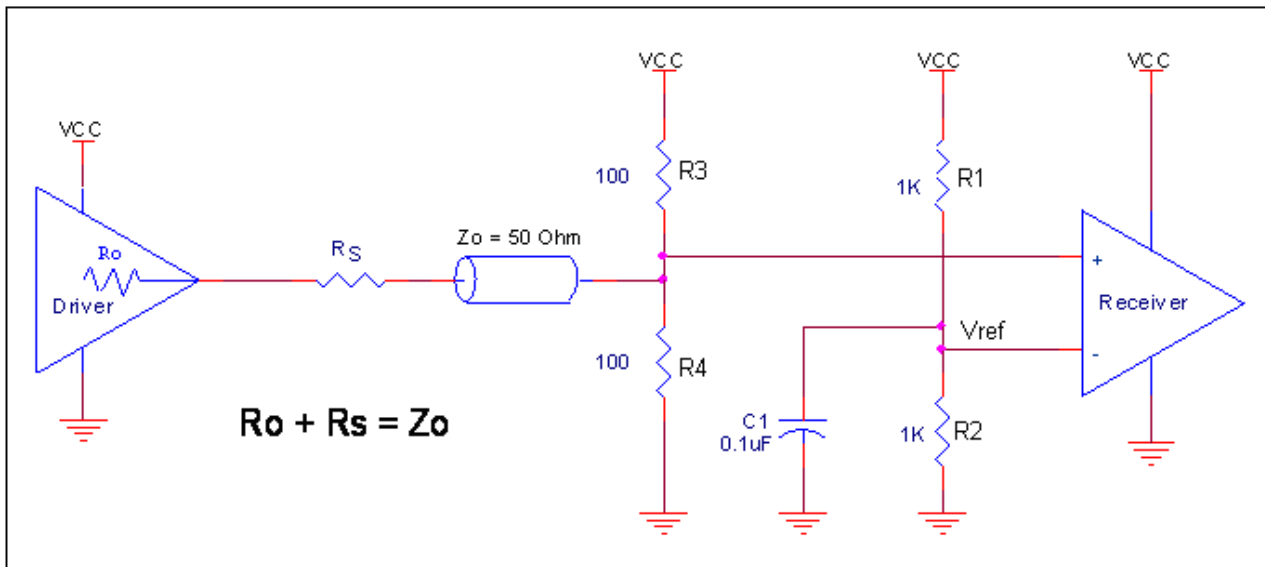
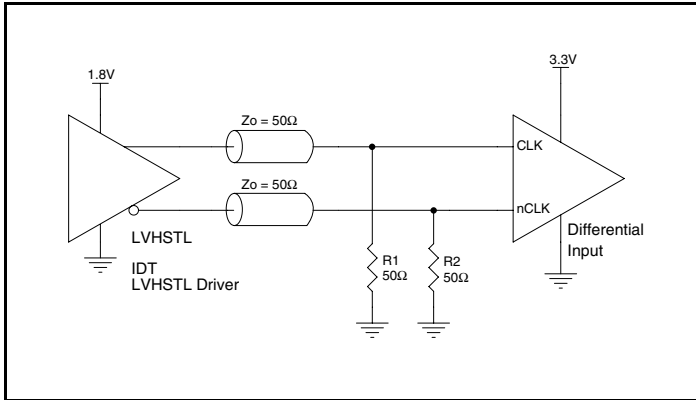

Figure 1. Recommended Schematic for Wiring a Differential Input to Accept Single-ended Levels

### 3.3V Differential Clock Input Interface

The CLK /nCLK accepts LVDS, LVPECL, LVHSTL, SSTL, HCSL and other differential signals. Both  $V_{SWING}$  and  $V_{OH}$  must meet the  $V_{PP}$  and  $V_{CMR}$  input requirements. *Figures 3A to 3F* show interface examples for the CLK/nCLK input driven by the most common driver types. The input interfaces suggested here are examples only.

Please consult with the vendor of the driver component to confirm the driver termination requirements. For example, in Figure 3A, the input termination applies for IDT open emitter LVHSTL drivers. If you are using an LVHSTL driver from another vendor, use their termination recommendation.



**Figure 3A. CLK/nCLK Input Driven by an IDT Open Emitter LVHSTL Driver**

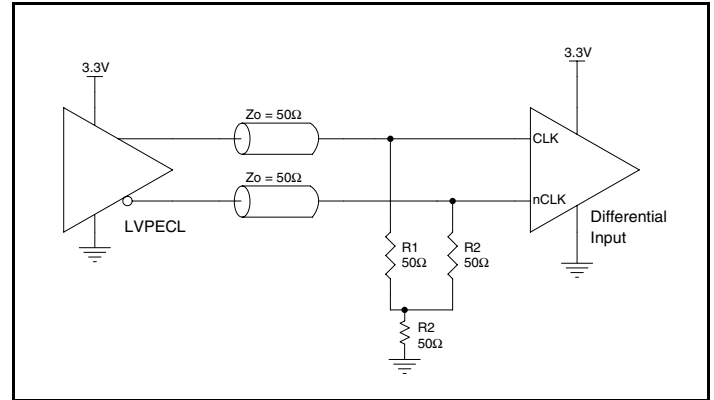

**Figure 3B. CLK/nCLK Input Driven by a 3.3V LVPECL Driver**

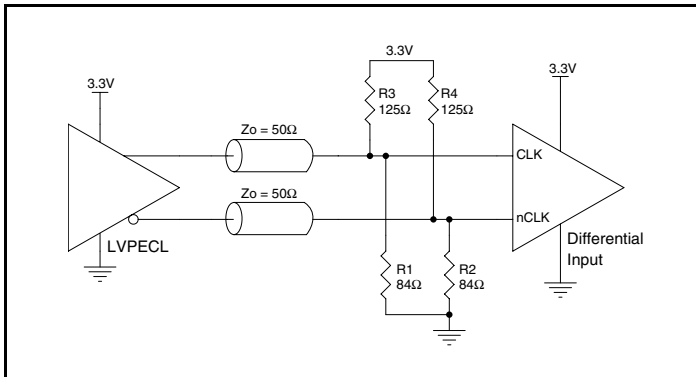

**Figure 3C. CLK/nCLK Input Driven by a 3.3V LVPECL Driver**

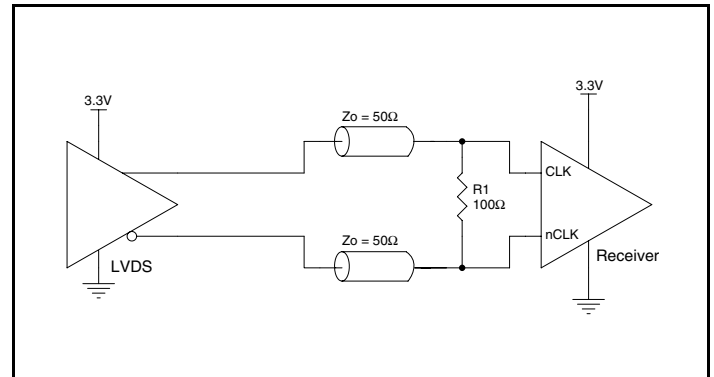

**Figure 3D. CLK/nCLK Input Driven by a 3.3V LVDS Driver**

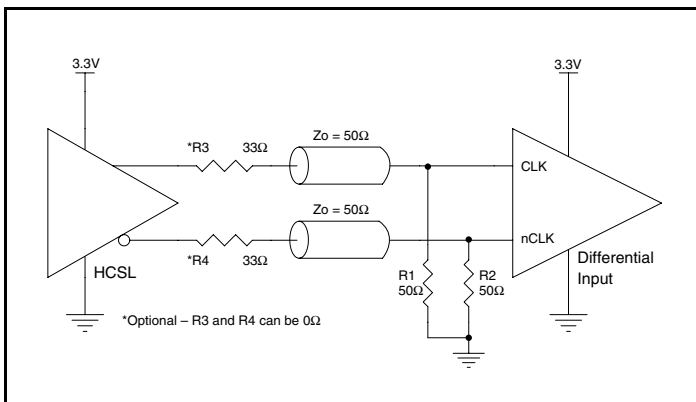

**Figure 3E. CLK/nCLK Input Driven by a 3.3V HCSL Driver**

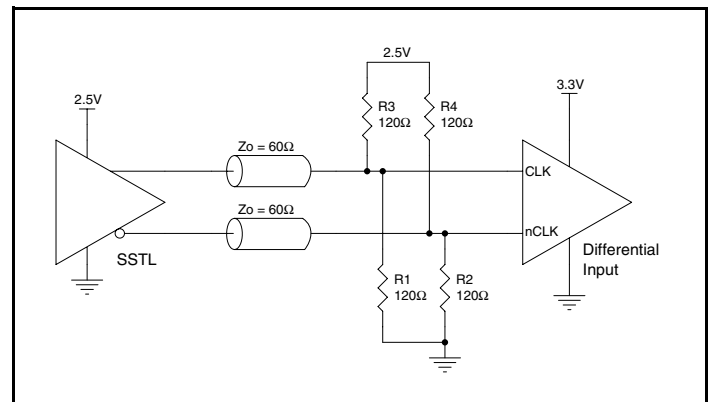

**Figure 3F. CLK/nCLK Input Driven by a 2.5V SSTL Driver**

### 3.3V LVPECL Clock Input Interface

The PCLK/nPCLK accepts LVPECL, CML, SSTL and other differential signals. Both  $V_{SWING}$  and  $V_{OH}$  must meet the  $V_{PP}$  and  $V_{CMR}$  input requirements. Figures 4A to 4E show interface examples for the PCLK/nPCLK input driven by the most common driver types.

The input interfaces suggested here are examples only. If the driver is from another vendor, use their termination recommendation. Please consult with the vendor of the driver component to confirm the driver termination requirements.

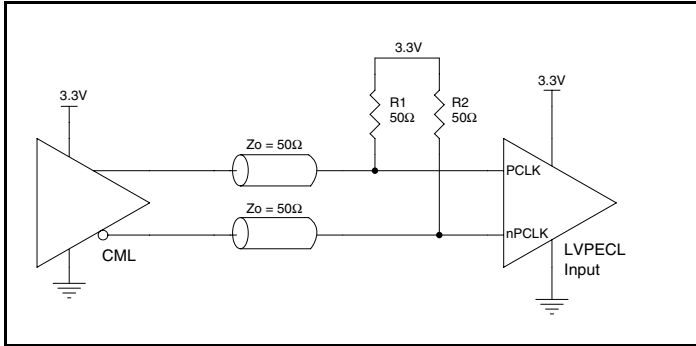

Figure 4A. PCLK/nPCLK Input Driven by a CML Driver

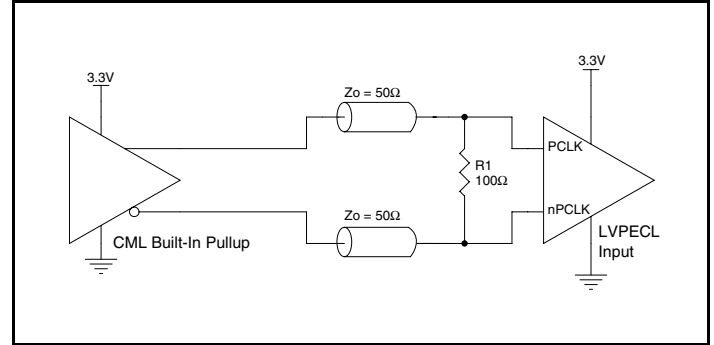

Figure 4B. PCLK/nPCLK Input Driven by a Built-In Pullup CML Driver

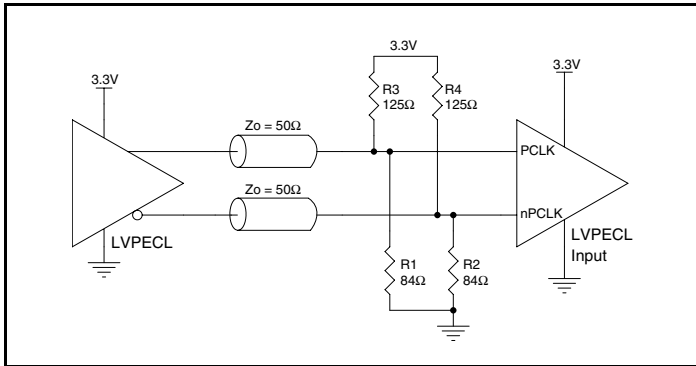

Figure 4C. PCLK/nPCLK Input Driven by a 3.3V LVPECL Driver

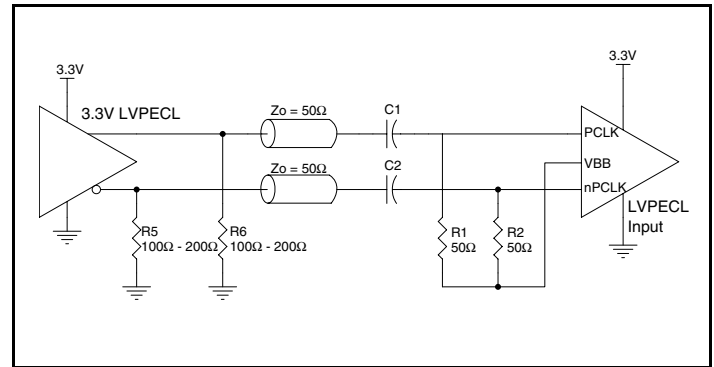

Figure 4D. PCLK/nPCLK Input Driven by a 3.3V LVPECL Driver with AC Couple

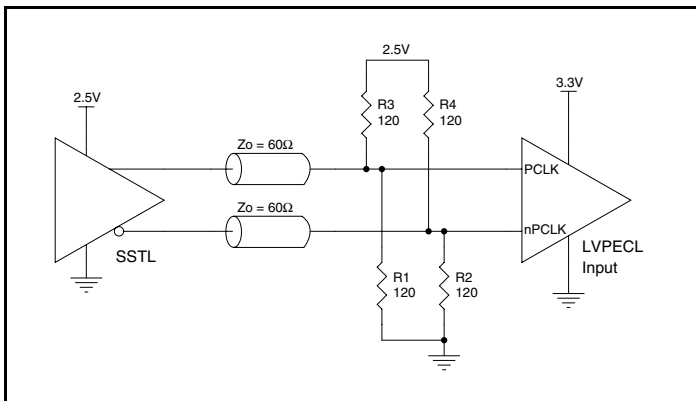

Figure 4E. PCLK/nPCLK Input Driven by a 2.5V SSTL Driver

## Recommendations for Unused Input and Output Pins

### Inputs:

#### CLK/nCLK INPUTS

For applications not requiring the use of the differential input, both CLK and nCLK can be left floating. Though not required, but for additional protection, a 1k $\Omega$  resistor can be tied from CLK to ground.

#### PCLK/nPCLK INPUTS

For applications not requiring the use of the differential input, both PCLK and nPCLK can be left floating. Though not required, but for additional protection, a 1k $\Omega$  resistor can be tied from PCLK to ground.

#### LVC MOS Control Pins

All control pins have internal pull-ups or pull-downs; additional resistance is not required but can be added for additional protection. A 1k $\Omega$  resistor can be used.

### Outputs:

#### LVDS Outputs

All unused LVDS outputs should be terminated with 100 $\Omega$  resistor between the differential pair.

## LVDS Driver Termination

A general LVDS interface is shown in *Figure 5*. Standard termination for LVDS type output structure requires both a 100 $\Omega$  parallel resistor at the receiver and a 100 $\Omega$  differential transmission line environment. In order to avoid any transmission line reflection issues, the 100 $\Omega$  resistor must be placed as close to the receiver as possible. IDT offers a full line of LVDS compliant devices with two types of output structures: current source and voltage source. The standard

termination schematic as shown in *Figure 5* can be used with either type of output structure. If using a non-standard termination, it is recommended to contact IDT and confirm if the output is a current source or a voltage source type structure. In addition, since these outputs are LVDS compatible, the amplitude and common mode input range of the input receivers should be verified for compatibility with the output.

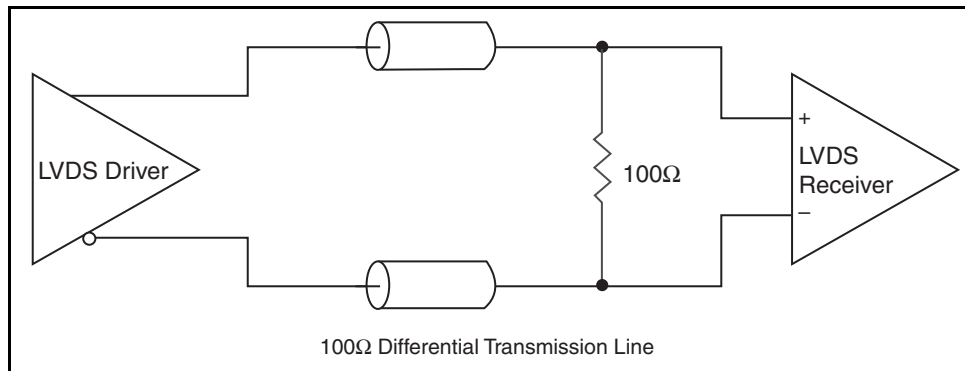

**Figure 5. Typical LVDS Driver Termination**

## Power Considerations

This section provides information on power dissipation and junction temperature for the ICS8543. Equations and example calculations are also provided.

### 1. Power Dissipation.

The total power dissipation for the ICS8543 is the sum of the core power plus the power dissipated in the load(s). The following is the power dissipation for  $V_{DD} = 3.3V + 5\% = 3.465V$ , which gives worst case results.

- Power (core)<sub>MAX</sub> =  $V_{DD\_MAX} * I_{DD\_MAX} = 3.465V * 50mA = 173.25mW$

### 2. Junction Temperature.

Junction temperature,  $T_j$ , is the temperature at the junction of the bond wire and bond pad directly affects the reliability of the device. The maximum recommended junction temperature is 125°C. Limiting the internal transistor junction temperature,  $T_j$ , to 125°C ensures that the bond wire and bond pad temperature remains below 125°C.

The equation for  $T_j$  is as follows:  $T_j = \theta_{JA} * Pd\_total + T_A$

$T_j$  = Junction Temperature

$\theta_{JA}$  = Junction-to-Ambient Thermal Resistance

$Pd\_total$  = Total Device Power Dissipation (example calculation is in section 1 above)

$T_A$  = Ambient Temperature

In order to calculate junction temperature, the appropriate junction-to-ambient thermal resistance  $\theta_{JA}$  must be used. Assuming no air flow and a multi-layer board, the appropriate value is 73.2°C/W per Table 6 below.

Therefore,  $T_j$  for an ambient temperature of 70°C with all outputs switching is:

$$70^\circ\text{C} + 0.173\text{W} * 73.2^\circ\text{C/W} = 82.7^\circ\text{C}. \text{ This is below the limit of } 125^\circ\text{C}.$$

This calculation is only an example.  $T_j$  will obviously vary depending on the number of loaded outputs, supply voltage, air flow and the type of board (multi-layer).

**Table 6. Thermal Resistance  $\theta_{JA}$  for 20 Lead TSSOP, Forced Convection**

Linear Feet per Minute	$\theta_{JA}$ by Velocity		
	0	200	500
Single-Layer PCB, JEDEC Standard Test Boards	114.5°C/W	98.0°C/W	88.0°C/W
Multi-Layer PCB, JEDEC Standard Test Boards	73.2°C/W	66.6°C/W	63.5°C/W



## Ordering Information

Table 9. Ordering Information

Part/Order Number	Marking	Package	Shipping Packaging	Temperature
8543BG	ICS8543BG	20 Lead TSSOP	Tube	0°C to 70°C
8543BGT	ICS8543BG	20 Lead TSSOP	2500 Tape & Reel	0°C to 70°C
8543BGLF	ICS8543BGLF	"Lead-Free" 20 Lead TSSOP	Tube	0°C to 70°C
8543BGLFT	ICS8543BGLF	"Lead-Free" 20 Lead TSSOP	2500 Tape & Reel	0°C to 70°C

NOTE: Parts that are ordered with an "LF" suffix to the part number are the Pb-Free configuration and are RoHS compliant.





## IMPORTANT NOTICE AND DISCLAIMER

RENESAS ELECTRONICS CORPORATION AND ITS SUBSIDIARIES (“RENESAS”) PROVIDES TECHNICAL SPECIFICATIONS AND RELIABILITY DATA (INCLUDING DATASHEETS), DESIGN RESOURCES (INCLUDING REFERENCE DESIGNS), APPLICATION OR OTHER DESIGN ADVICE, WEB TOOLS, SAFETY INFORMATION, AND OTHER RESOURCES “AS IS” AND WITH ALL FAULTS, AND DISCLAIMS ALL WARRANTIES, EXPRESS OR IMPLIED, INCLUDING, WITHOUT LIMITATION, ANY IMPLIED WARRANTIES OF MERCHANTABILITY, FITNESS FOR A PARTICULAR PURPOSE, OR NON-INFRINGEMENT OF THIRD-PARTY INTELLECTUAL PROPERTY RIGHTS.

These resources are intended for developers who are designing with Renesas products. You are solely responsible for (1) selecting the appropriate products for your application, (2) designing, validating, and testing your application, and (3) ensuring your application meets applicable standards, and any other safety, security, or other requirements. These resources are subject to change without notice. Renesas grants you permission to use these resources only to develop an application that uses Renesas products. Other reproduction or use of these resources is strictly prohibited. No license is granted to any other Renesas intellectual property or to any third-party intellectual property. Renesas disclaims responsibility for, and you will fully indemnify Renesas and its representatives against, any claims, damages, costs, losses, or liabilities arising from your use of these resources. Renesas' products are provided only subject to Renesas' Terms and Conditions of Sale or other applicable terms agreed to in writing. No use of any Renesas resources expands or otherwise alters any applicable warranties or warranty disclaimers for these products.

(Disclaimer Rev.1.01 Jan 2024)

### Corporate Headquarters

TOYOSU FORESIA, 3-2-24 Toyosu,  
Koto-ku, Tokyo 135-0061, Japan  
[www.renesas.com](http://www.renesas.com)

### Trademarks

Renesas and the Renesas logo are trademarks of Renesas Electronics Corporation. All trademarks and registered trademarks are the property of their respective owners.

### Contact Information

For further information on a product, technology, the most up-to-date version of a document, or your nearest sales office, please visit [www.renesas.com/contact-us/](http://www.renesas.com/contact-us/).

## Looking for pricing, stock, or lifecycle information?

Click below to explore more details on WIN SOURCE:

-  [View 8543BGLF on WIN SOURCE](#)
-  [Renesas Electronics America](#) Information

## Optimize Your Supply Chain with WIN SOURCE Solutions

-  Global Sourcing Solution
-  Obsolete Management
-  Cost Control Management
-  Shortage Management
-  Alternative Solution
-  Excess Inventory Management