



**THE DATASHEET OF**  
**85310AYI-11LF**



### General Description

The 85310I-11 is a low skew, high performance 1-to-10 Differential-to-2.5V/3.3V ECL/LVPECL Fanout Buffer. The CLKx, nCLKx pairs can accept most standard differential input levels. The 85310I-11 is characterized to operate from either a 2.5V or a 3.3V power supply. Guaranteed output and part-to-part skew characteristics make the 85310I-11 ideal for those clock distribution applications demanding well defined performance and repeatability.

### Features

- Ten differential 2.5V, 3.3V LVPECL/ECL output pair
- Two selectable differential input pairs
- Differential CLKx, nCLKx pairs can accept the following interface levels: LVPECL, LVDS, LVHSTL, SSTL, HCSL
- Maximum output frequency: 700MHz
- Translates any single ended input signal to 3.3V LVPECL levels with resistor bias on nCLK input
- Output skew: 30ps (typical)
- Part-to-part skew: 140ps (typical)
- Propagation delay: 2ns (typical)
- Additive phase jitter, RMS: <0.13ps (typical)
- LVPECL mode operating voltage supply range:  $V_{CC} = 2.375V$  to  $3.8V$ ,  $V_{EE} = 0V$
- ECL mode operating voltage supply range:  $V_{CC} = 0V$ ,  $V_{EE} = -3.8V$  to  $-2.375V$
- $-40^{\circ}C$  to  $85^{\circ}C$  ambient operating temperature
- Available in lead-free RoHS compliant package

### Block Diagram

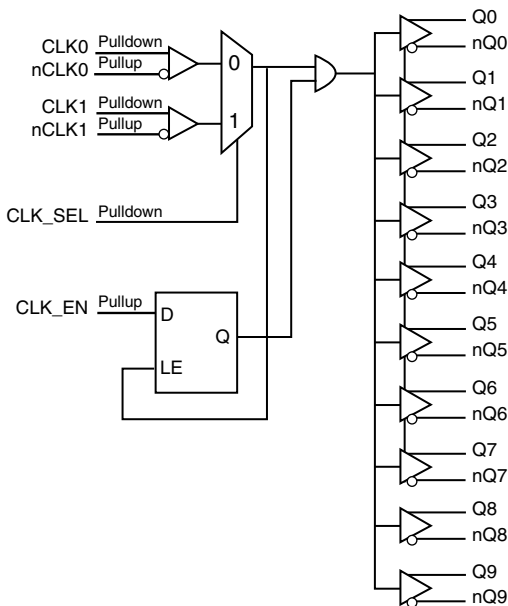

### Pin Assignment

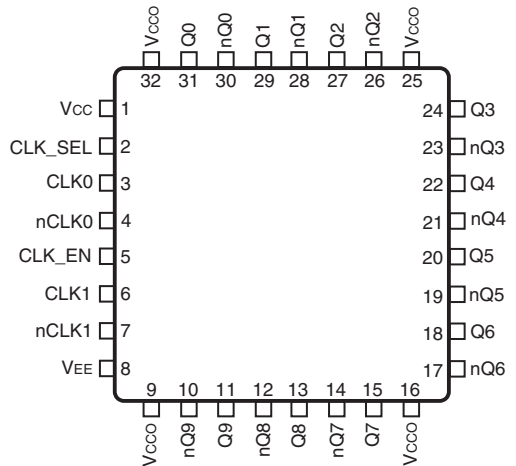

**85310I-11**

**32-Lead LQFP**

**7mm x 7mm x 1.4mm package body**

**Y Package**

**Top View**

**Table 1. Pin Descriptions**

Number	Name	Type		Description
1	V <sub>CC</sub>	Power		Positive supply pin.
2	CLK_SEL	Input	Pulldown	Clock select input. When HIGH, selects CLK1, nCLK1 inputs. When LOW, selects CLK0, nCLK0 inputs. LVCMOS / LVTTTL interface levels.
3	CLK0	Input	Pulldown	Non-inverting differential clock input.
4	nCLK0	Input	Pullup	Inverting differential clock input.
5	CLK_EN	Input	Pullup	Synchronizing clock enable. When HIGH, clock outputs follow clock input. When LOW, Q outputs are forced low, nQ outputs are forced high. LVCMOS / LVTTTL interface levels.
6	CLK1	Input	Pulldown	Non-inverting differential clock input.
7	nCLK1	Input	Pullup	Inverting differential clock input.
8	V <sub>EE</sub>	Power		Negative supply pin.
9, 16, 25, 32	V <sub>CCO</sub>	Power		Output supply pins.
10, 11	nQ9, Q9	Output		Differential output pair. LVPECL interface levels.
12, 13	nQ8, Q8	Output		Differential output pair. LVPECL interface levels.
14, 15	nQ7, Q7	Output		Differential output pair. LVPECL interface levels.
17, 18	nQ6, Q6	Output		Differential output pair. LVPECL interface levels.
19, 20	nQ5, Q5	Output		Differential output pair. LVPECL interface levels.
21, 22	nQ4, Q4	Output		Differential output pair. LVPECL interface levels.
23, 24	nQ3, Q3	Output		Differential output pair. LVPECL interface levels.
26, 27	nQ2, Q2	Output		Differential output pair. LVPECL interface levels.
28, 29	nQ1, Q1	Output		Differential output pair. LVPECL interface levels.
30, 31	nQ0, Q0	Output		Differential output pair. LVPECL interface levels.

NOTE: *Pullup* and *Pulldown* refer to internal input resistors. See Table 2, *Pin Characteristics*, for typical values.

**Table 2. Pin Characteristics**

Symbol	Parameter	Test Conditions	Minimum	Typical	Maximum	Units
C <sub>IN</sub>	Input Capacitance			4		pF
R <sub>PULLUP</sub>	Input Pullup Resistor			51		kΩ
R <sub>PULLDOWN</sub>	Input Pulldown Resistor			51		kΩ

## Function Tables

**Table 3A. Control Input Function Table**

Inputs		Outputs	
CLK_EN	Selected Source	Q[0:9]	nQ[0:9]
0	CLK0, nCLK0	Disabled; LOW	Disabled; HIGH
1	CLK1, nCLK1	Enabled	Enabled

After CLK\_EN switches, the clock outputs are disabled or enabled following a rising and falling input clock edge as shown in Figure 1. In the active mode, the state of the outputs are a function of the CLK0, nCLK0 and CLK1, nCLK1 input as described in Table 3B.

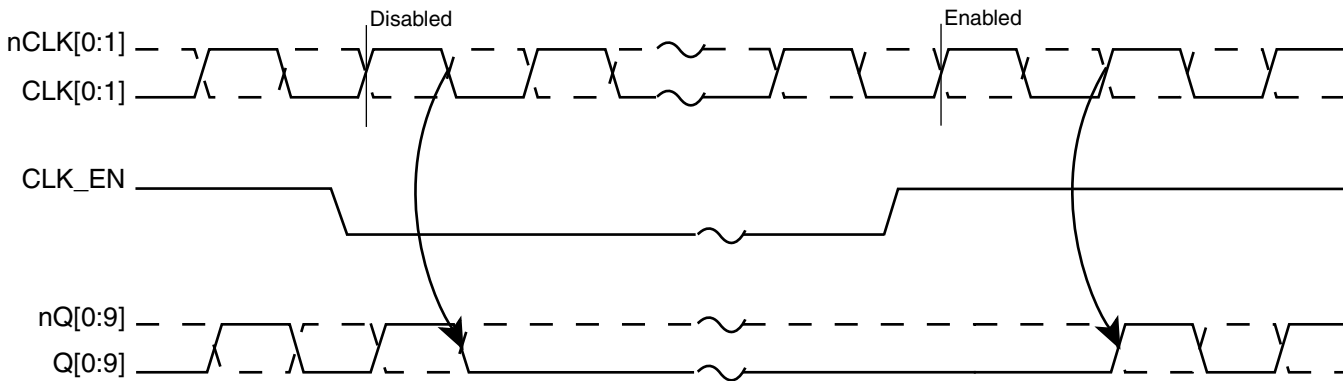
**Figure 1. CLK\_EN Timing Diagram**
**Table 3B. Clock Input Function Table**

Inputs		Outputs		Input to Output Mode	Polarity
CLK0 or CLK1	nCLK0 or nCLK1	Q[0:9]	nQ[0:9]		
0	1	LOW	HIGH	Differential to Differential	Non-Inverting
1	0	HIGH	LOW	Differential to Differential	Non-Inverting
0	Biased; NOTE 1	LOW	HIGH	Single-ended to Differential	Non-Inverting
1	Biased; NOTE 1	HIGH	LOW	Single-ended to Differential	Non-Inverting
Biased; NOTE 1	0	HIGH	LOW	Single-ended to Differential	Inverting
Biased; NOTE 1	1	LOW	HIGH	Single-ended to Differential	Inverting

NOTE 1: Please refer to the Applications Information, *Wiring the Differential Input to Accept Single-ended Levels*.

## Absolute Maximum Ratings

NOTE: Stresses beyond those listed under *Absolute Maximum Ratings* may cause permanent damage to the device. These ratings are stress specifications only. Functional operation of product at these conditions or any conditions beyond those listed in the *DC Characteristics* or *AC Characteristics* is not implied. Exposure to absolute maximum rating conditions for extended periods may affect product reliability.

Item	Rating
Supply Voltage, $V_{CC}$	4.6V
Inputs, $V_I$	-0.5V to $V_{CC} + 0.5V$
Outputs, $I_O$ Continuous Current Surge Current	50mA 100mA
Package Thermal Impedance, $\theta_{JA}$	47.9°C/W (0 lfpm)
Storage Temperature, $T_{STG}$	-65°C to 150°C

## DC Electrical Characteristics

**Table 4A. Power Supply DC Characteristics,  $V_{CC} = V_{CCO} = 2.375V$  to  $3.8V$ ;  $V_{EE} = 0V$ ,  $T_A = -40^\circ C$  to  $85^\circ C$**

Symbol	Parameter	Test Conditions	Minimum	Typical	Maximum	Units
$V_{CC}$	Positive Supply Voltage		2.375	3.3	3.8	V
$V_{CCO}$	Output Supply Voltage		2.375	3.3	3.8	V
$I_{EE}$	Power Supply Current				120	mA

**Table 4B. LVCMOS/LVTTL DC Characteristics,  $V_{CC} = V_{CCO} = 2.375V$  to  $3.8V$ ;  $V_{EE} = 0V$ ,  $T_A = -40^\circ C$  to  $85^\circ C$**

Symbol	Parameter	Test Conditions	Minimum	Typical	Maximum	Units
$V_{IH}$	Input High Voltage		2		$V_{CC} + 0.3$	V
$V_{IL}$	Input Low Voltage		-0.3		0.8	V
$I_{IH}$	Input High Current	CLK_EN	$V_{CC} = V_{IN} = 3.8V$		5	$\mu A$
		CLK_SEL	$V_{CC} = V_{IN} = 3.8V$		150	$\mu A$
$I_{IL}$	Input Low Current	CLK_EN	$V_{CC} = 3.8V, V_{IN} = 0V$	-150		$\mu A$
		CLK_SEL	$V_{CC} = 3.8V, V_{IN} = 0V$	-5		$\mu A$

**Table 4C. DC Characteristics,  $V_{CC} = V_{CCO} = 2.375V$  to  $3.8V$ ;  $V_{EE} = 0V$ ,  $T_A = -40^\circ C$  to  $85^\circ C$**

Symbol	Parameter	Test Conditions	Minimum	Typical	Maximum	Units
$I_{IH}$	Input High Current	CLK[0:1],	$V_{CC} = V_{IN} = 3.8V$		150	$\mu A$
		nCLK[0:1]	$V_{CC} = V_{IN} = 3.8V$		5	$\mu A$
$I_{IL}$	Input Low Current	CLK[0:1]	$V_{CC} = 3.8V, V_{IN} = 0V$	-5		$\mu A$
		nCLK[0:1]	$V_{CC} = 3.8V, V_{IN} = 0V$	-150		$\mu A$
$V_{PP}$	Peak-to-Peak Voltage; NOTE 1		0.15		1.3	V
$V_{CMR}$	Common Mode Range; NOTE 1, 2		$V_{EE} + 0.5$		$V_{CC} - 0.85$	V

NOTE 1:  $V_{IL}$  should not be less than -0.3V.

NOTE 2: Common mode voltage is defined as  $V_{IH}$ .

**Table 4D. LVPECL DC Characteristics,  $V_{CC} = V_{CCO} = 2.375V$  to  $3.8V$ ;  $V_{EE} = 0V$ ,  $T_A = -40^{\circ}C$  to  $85^{\circ}C$** 

Symbol	Parameter	Test Conditions	Minimum	Typical	Maximum	Units
$V_{OH}$	Output High Voltage; NOTE 1		$V_{CCO} - 1.4$		$V_{CCO} - 0.9$	V
$V_{OL}$	Output Low Voltage; NOTE 1		$V_{CCO} - 2.0$		$V_{CCO} - 1.7$	V
$V_{swing}$	Peak-to-Peak Output Voltage Swing		0.6		1.0	V

NOTE 1: Outputs terminated with  $50\Omega$  to  $V_{CCO} - 2V$ .

## AC Electrical Characteristics

**Table 5. AC Characteristics,  $V_{CC} = V_{CCO} = 2.375V$  to  $3.8V$ ;  $V_{EE} = 0V$ ,  $T_A = -40^{\circ}C$  to  $85^{\circ}C$** 

Symbol	Parameter	Test Conditions	Minimum	Typical	Maximum	Units
$f_{MAX}$	Output Frequency				700	MHz
$t_{PD}$	Propagation Delay; NOTE 1			2	2.5	ns
$t_{sk(pp)}$	Part-to-Part Skew; NOTE 2, 3			140	340	ps
$t_{sk(o)}$	Output Skew; NOTE 3, 4			30	55	ps
$t_{jit}$	Additive Phase Jitter, RMS; refer to Additive Phase Jitter section			<0.13		ps
$t_R / t_F$	Output Rise/Fall Time	20% to 80%	200		700	ps
odc	Output Duty Cycle		47		53	%

NOTE: Electrical parameters are guaranteed over the specified ambient operating temperature range, which is established when the device is mounted in a test socket with maintained transverse airflow greater than 500 lfm. The device will meet specifications after thermal equilibrium has been reached under these conditions.

NOTE: All parameters measured at 500MHz, unless otherwise noted.

NOTE 1: Measured from the differential input crossing point to the differential output crossing point.

NOTE 2: Defined as skew between outputs on different devices operating at the same supply voltage, same frequency, same temperature and with equal load conditions. Using the same type of inputs on each device, the outputs are measured at the differential cross points.

NOTE 3: This parameter is defined according with JEDEC Standard 65.

NOTE 4: Defined as skew between outputs at the same supply voltage and with equal load conditions. Measured at the output differential cross points.

## Additive Phase Jitter

The spectral purity in a band at a specific offset from the fundamental compared to the power of the fundamental is called the **dBc Phase Noise**. This value is normally expressed using a Phase noise plot and is most often the specified plot in many applications. Phase noise is defined as the ratio of the noise power present in a 1Hz band at a specified offset from the fundamental frequency to the power value of the fundamental. This ratio is expressed in decibels (dBm) or a ratio

of the power in the 1Hz band to the power in the fundamental. When the required offset is specified, the phase noise is called a **dBc** value, which simply means dBm at a specified offset from the fundamental. By investigating jitter in the frequency domain, we get a better understanding of its effects on the desired application over the entire time record of the signal. It is mathematically possible to calculate an expected bit error rate given a phase noise plot.

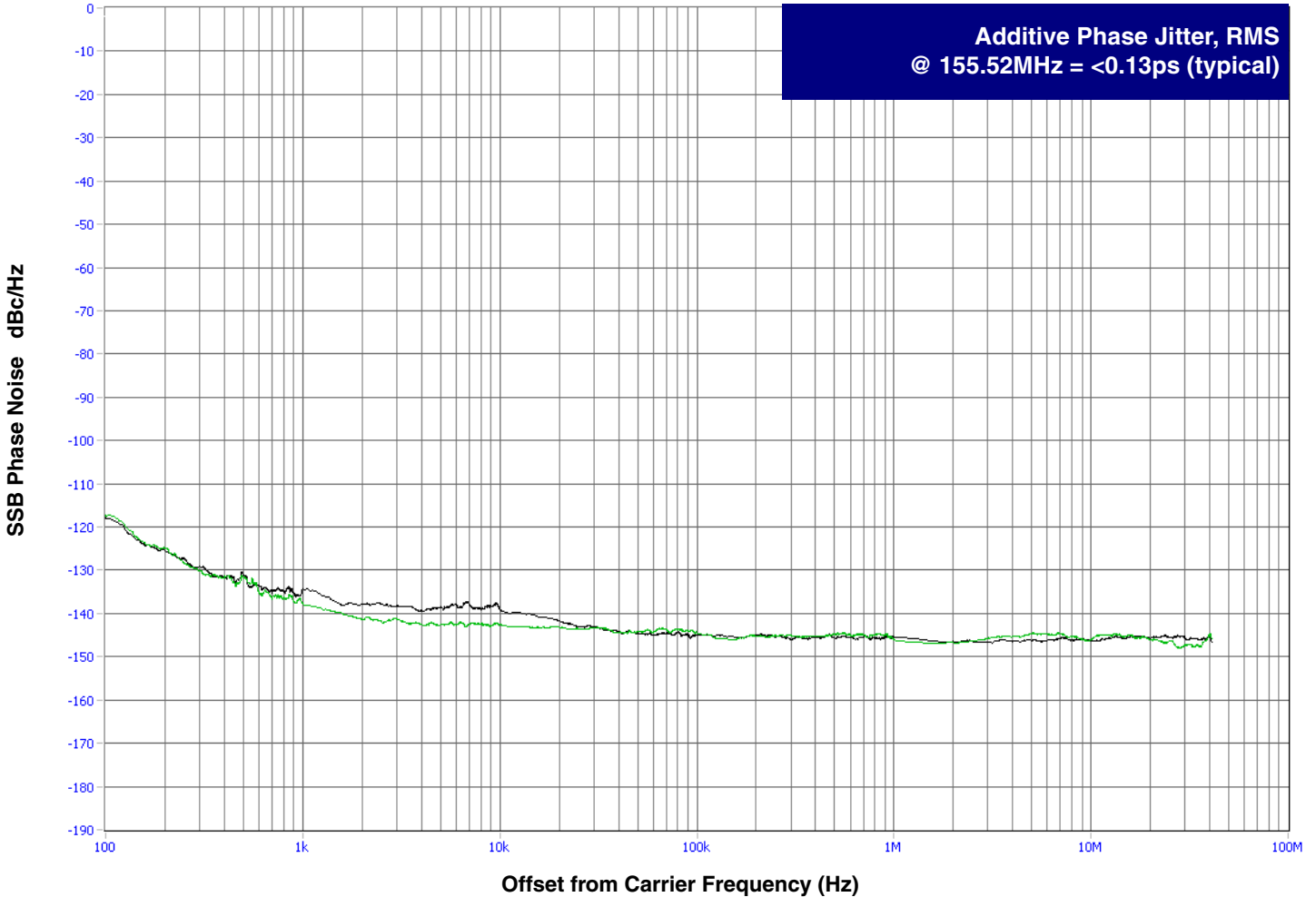

As with most timing specifications, phase noise measurements has issues relating to the limitations of the equipment. Often the noise floor of the equipment is higher than the noise floor of the device. This

is illustrated above. The device meets the noise floor of what is shown, but can actually be lower. The phase noise is dependent on the input source and measurement equipment.

### Parameter Measurement Information

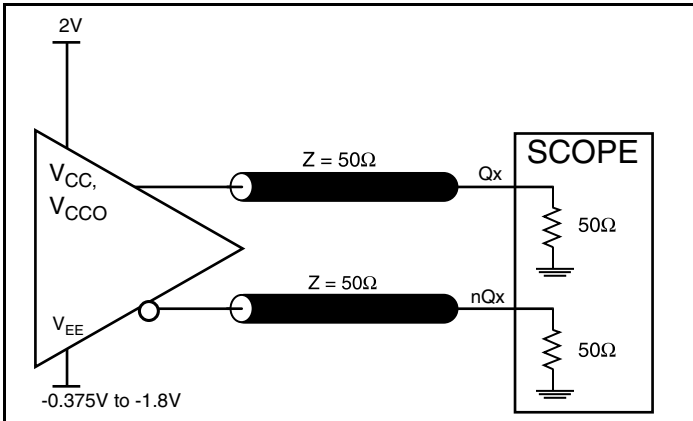

LVPECL Output Load AC Test Circuit

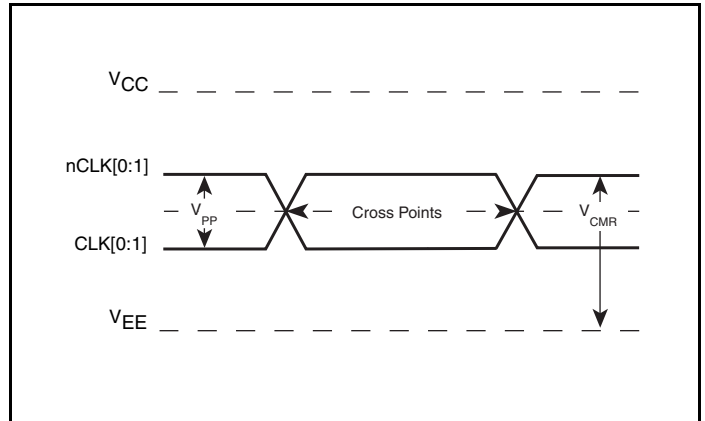

Differential Input Level

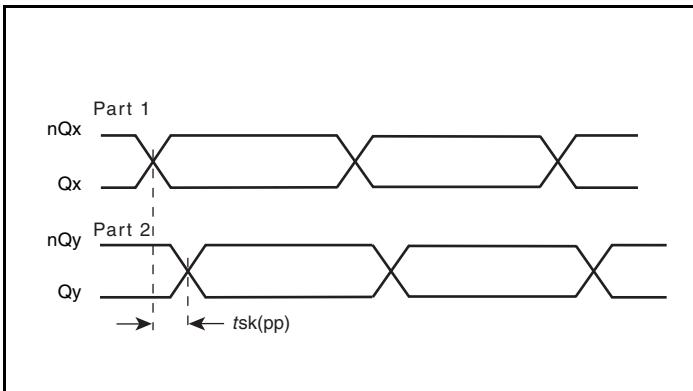

Part-to-Part Skew

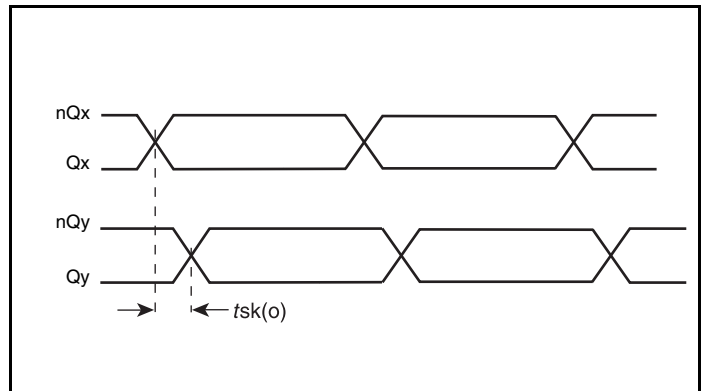

Output Skew

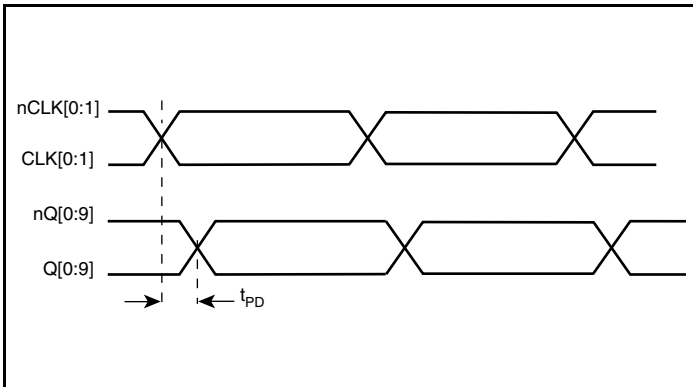

Propagation Delay

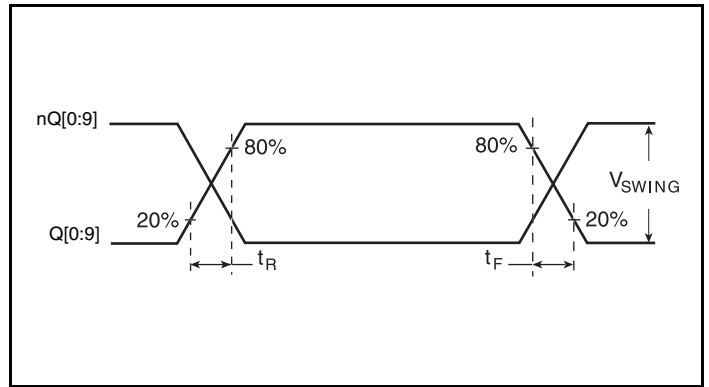

Output Rise/Fall Time

## Parameter Measurement Information

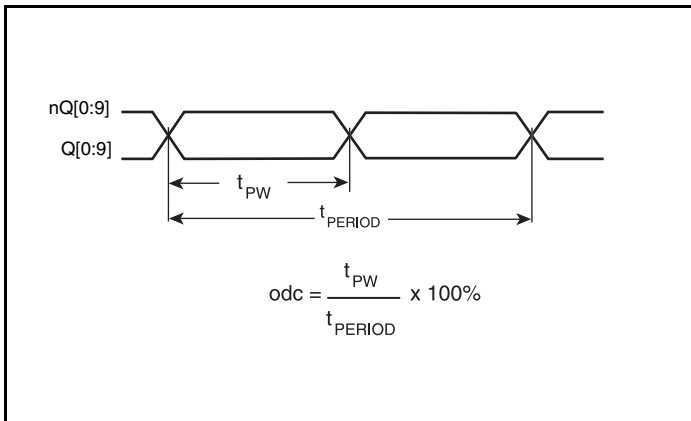

### Output Duty Cycle/Pulse Width/Period

## Applications Information

### Wiring the Differential Input to Accept Single-Ended Levels

Figure 2 shows how a differential input can be wired to accept single ended levels. The reference voltage  $V_{REF} = V_{CC}/2$  is generated by the bias resistors R1 and R2. The bypass capacitor (C1) is used to help filter noise on the DC bias. This bias circuit should be located as close to the input pin as possible. The ratio of R1 and R2 might need to be adjusted to position the  $V_{REF}$  in the center of the input voltage swing. For example, if the input clock swing is 2.5V and  $V_{CC} = 3.3V$ , R1 and R2 value should be adjusted to set  $V_{REF}$  at 1.25V. The values below are for when both the single ended swing and  $V_{CC}$  are at the same voltage. This configuration requires that the sum of the output impedance of the driver ( $R_o$ ) and the series resistance ( $R_s$ ) equals the transmission line impedance. In addition, matched termination at the input will attenuate the signal in half. This can be done in one of two ways. First, R3 and R4 in parallel should equal the transmission

line impedance. For most 50Ω applications, R3 and R4 can be 100Ω. The values of the resistors can be increased to reduce the loading for slower and weaker LVCMOS driver. When using single-ended signaling, the noise rejection benefits of differential signaling are reduced. Even though the differential input can handle full rail LVCMOS signaling, it is recommended that the amplitude be reduced. The datasheet specifies a lower differential amplitude, however this only applies to differential signals. For single-ended applications, the swing can be larger, however  $V_{IL}$  cannot be less than -0.3V and  $V_{IH}$  cannot be more than  $V_{CC} + 0.3V$ . Though some of the recommended components might not be used, the pads should be placed in the layout. They can be utilized for debugging purposes. The datasheet specifications are characterized and guaranteed by using a differential signal.

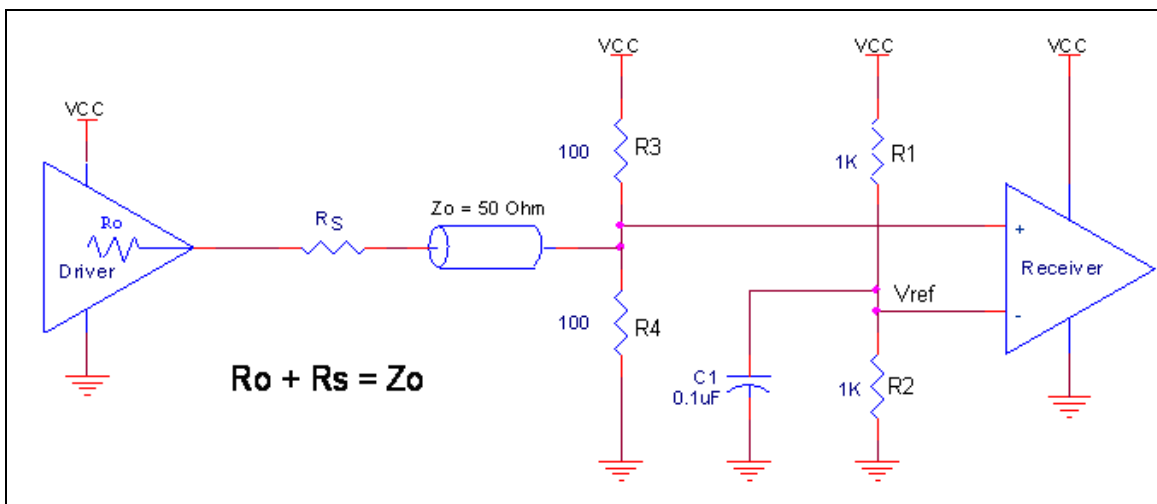
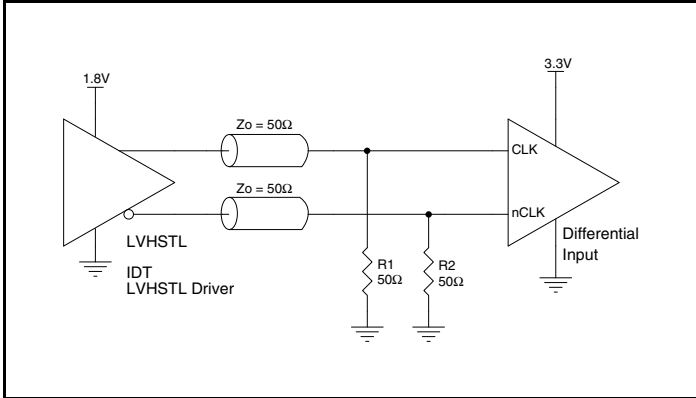

Figure 2. Recommended Schematic for Wiring a Differential Input to Accept Single-ended Levels

### Differential Clock Input Interface

The CLK /nCLK accepts LVDS, LVPECL, LVHSTL, SSTL, HCSL and other differential signals. Both  $V_{SWING}$  and  $V_{OH}$  must meet the  $V_{PP}$  and  $V_{CMR}$  input requirements. *Figures 3A to 3F* show interface examples for the CLK/nCLK input driven by the most common driver types. The input interfaces suggested here are examples only.

Please consult with the vendor of the driver component to confirm the driver termination requirements. For example, in Figure 3A, the input termination applies for IDT open emitter LVHSTL drivers. If you are using an LVHSTL driver from another vendor, use their termination recommendation.



**Figure 3A. CLK/nCLK Input Driven by an IDT Open Emitter LVHSTL Driver**

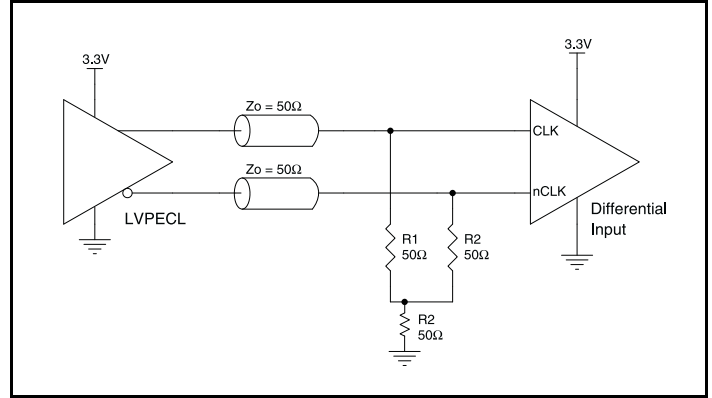

**Figure 3B. CLK/nCLK Input Driven by a 3.3V LVPECL Driver**

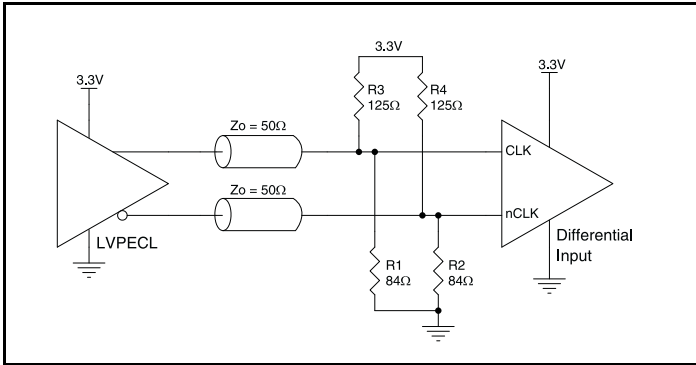

**Figure 3C. CLK/nCLK Input Driven by a 3.3V LVPECL Driver**

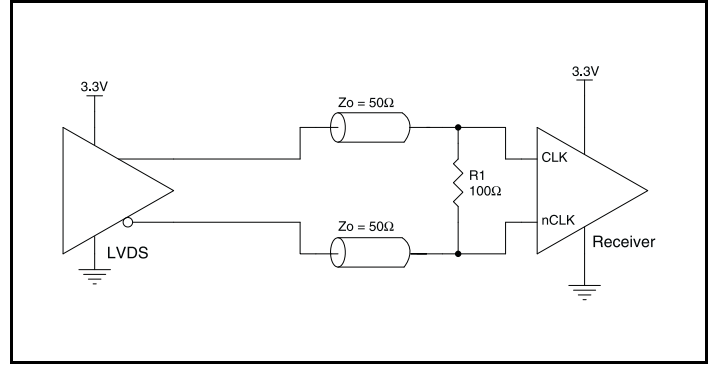

**Figure 3D. CLK/nCLK Input Driven by a 3.3V LVDS Driver**

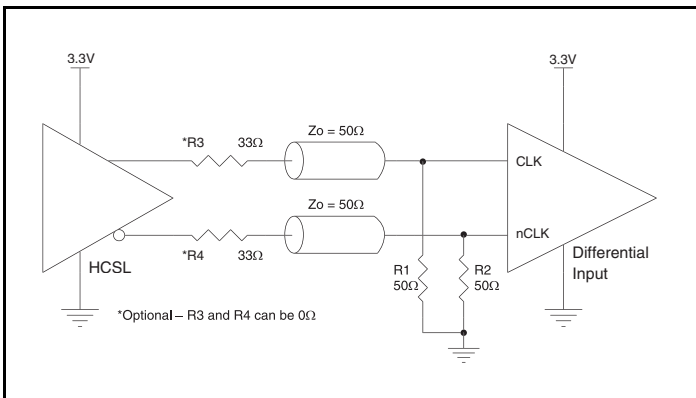

**Figure 3E. CLK/nCLK Input Driven by a 3.3V HCSL Driver**

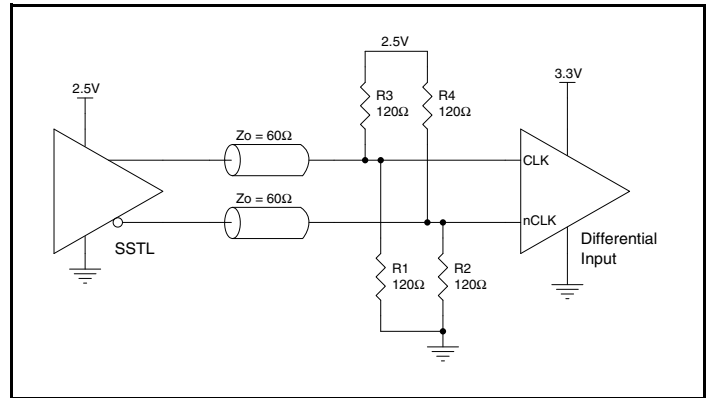

**Figure 3F. CLK/nCLK Input Driven by a 2.5V SSTL Driver**

## Recommendations for Unused Input Pins

### Inputs:

#### CLK/nCLK Inputs

For applications not requiring the use of the differential input, both CLK and nCLK can be left floating. Though not required, but for additional protection, a 1k $\Omega$  resistor can be tied from CLK to ground.

#### LVCMOS Control Pins

The control pins have an internal pullup and pulldown; additional resistance is not required but can be added for additional protection. A 1k $\Omega$  resistor can be used.

### Outputs:

#### LVPECL Outputs

All unused LVPECL outputs can be left floating. We recommend that there is no trace attached. Both sides of the differential output pair should either be left floating or terminated.

## Termination for 3.3V LVPECL Outputs

The clock layout topology shown below is a typical termination for LVPECL outputs. The two different layouts mentioned are recommended only as guidelines.

The differential outputs are low impedance follower outputs that generate ECL/LVPECL compatible outputs. Therefore, terminating resistors (DC current path to ground) or current sources must be used for functionality. These outputs are designed to drive 50 $\Omega$

transmission lines. Matched impedance techniques should be used to maximize operating frequency and minimize signal distortion.

*Figures 4A and 4B* show two different layouts which are recommended only as guidelines. Other suitable clock layouts may exist and it would be recommended that the board designers simulate to guarantee compatibility across all printed circuit and clock component process variations.

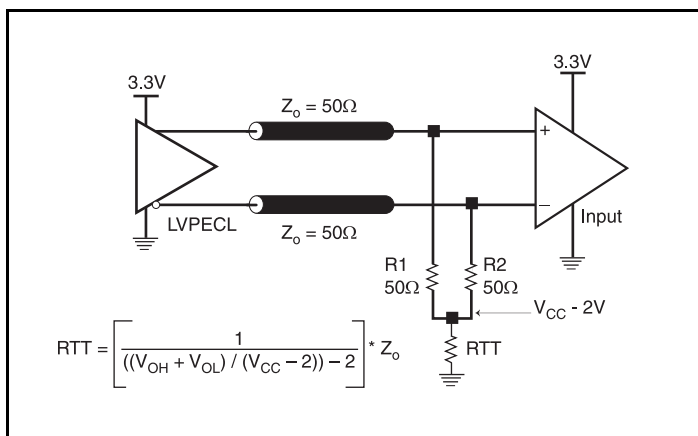

Figure 4A. 3.3V LVPECL Output Termination

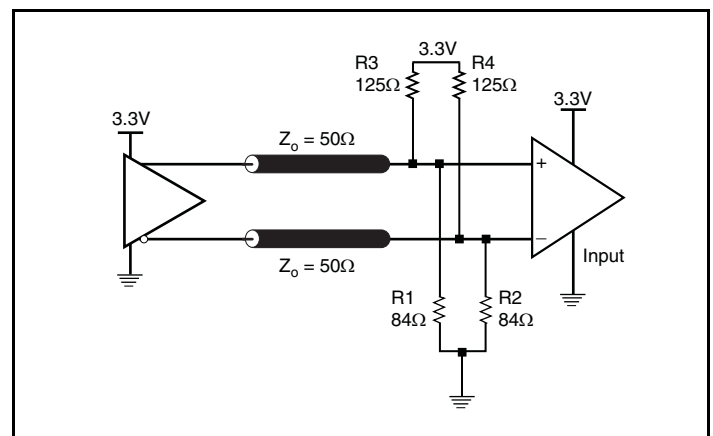

Figure 4B. 3.3V LVPECL Output Termination

### Termination for 2.5V LVPECL Outputs

Figure 5A and Figure 5B show examples of termination for 2.5V LVPECL driver. These terminations are equivalent to terminating  $50\Omega$  to  $V_{CC} - 2V$ . For  $V_{CC} = 2.5V$ , the  $V_{CC} - 2V$  is very close to ground

level. The R3 in Figure 5B can be eliminated and the termination is shown in Figure 5C.

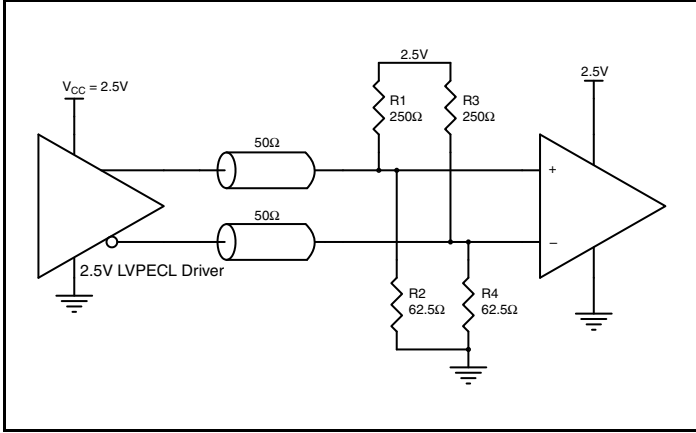

Figure 5A. 2.5V LVPECL Driver Termination Example

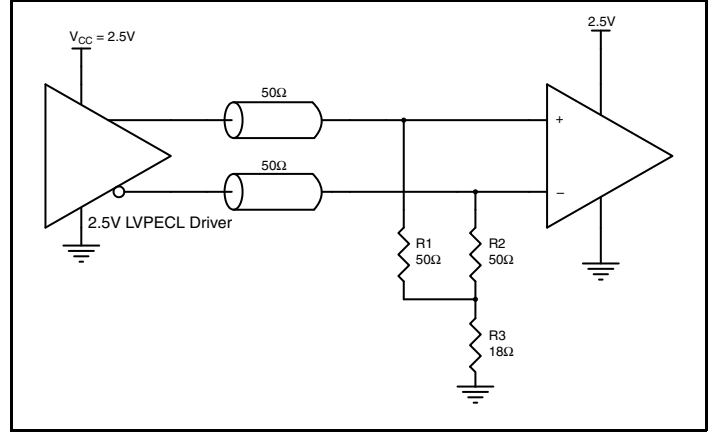

Figure 5B. 2.5V LVPECL Driver Termination Example

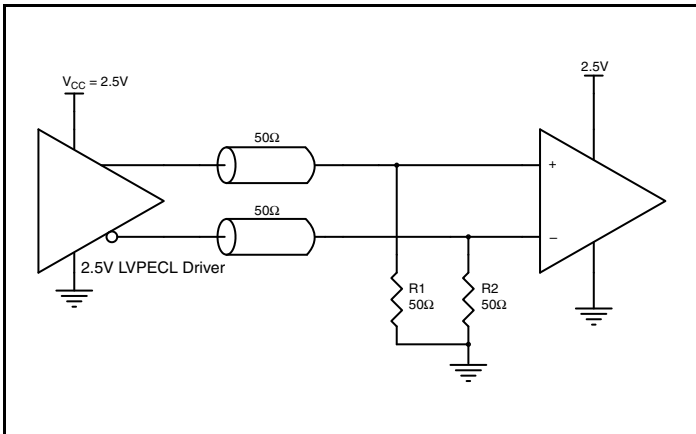

Figure 5C. 2.5V LVPECL Driver Termination Example

## Power Considerations

This section provides information on power dissipation and junction temperature for the ICS5311I-01. Equations and example calculations are also provided.

### 1. Power Dissipation.

The total power dissipation for the ICS5311I-01 is the sum of the core power plus the power dissipated in the load(s). The following is the power dissipation for  $V_{CC} = 3.8V$ , which gives worst case results.

NOTE: Please refer to Section 3 for details on calculating power dissipated in the load.

- Power (core)<sub>MAX</sub> =  $V_{CC\_MAX} * I_{EE\_MAX} = 3.8V * 120mA = 456mW$
- Power (outputs)<sub>MAX</sub> = **30mW/Loaded Output pair**  
If all outputs are loaded, the total power is  $10 * 30mW = 300mW$

**Total Power**<sub>MAX</sub> (3.8V, with all outputs switching) =  $456mW + 300mW = 756mW$

### 2. Junction Temperature.

Junction temperature,  $T_j$ , is the temperature at the junction of the bond wire and bond pad directly affects the reliability of the device. The maximum recommended junction temperature is 125°C. Limiting the internal transistor junction temperature,  $T_j$ , to 125°C ensures that the bond wire and bond pad temperature remains below 125°C.

The equation for  $T_j$  is as follows:  $T_j = \theta_{JA} * Pd\_total + T_A$

$T_j$  = Junction Temperature

$\theta_{JA}$  = Junction-to-Ambient Thermal Resistance

$Pd\_total$  = Total Device Power Dissipation (example calculation is in section 1 above)

$T_A$  = Ambient Temperature

In order to calculate junction temperature, the appropriate junction-to-ambient thermal resistance  $\theta_{JA}$  must be used. Assuming a moderate air flow of 200 linear feet per minute and a multi-layer board, the appropriate value is 42.1°C/W per Table 6 below.

Therefore,  $T_j$  for an ambient temperature of 85°C with all outputs switching is:

$$85^\circ\text{C} + 0.756\text{W} * 42.1^\circ\text{C/W} = 116.8^\circ\text{C}. \text{ This is well below the limit of } 125^\circ\text{C}.$$

This calculation is only an example.  $T_j$  will obviously vary depending on the number of loaded outputs, supply voltage, air flow and the type of board (single layer or multi-layer).

**Table 6. Thermal Resistance  $\theta_{JA}$  for 32 Lead LQFP, Forced Convection**

$\theta_{JA}$ by Velocity			
Linear Feet per Minute	0	200	500
Single-Layer PCB, JEDEC Standard Test Boards	67.8°C/W	55.9°C/W	50.1°C/W
Multi-Layer PCB, JEDEC Standard Test Boards	47.9°C/W	42.1°C/W	39.4°C/W
<b>NOTE:</b> Most modern PCB designs use multi-layered boards. The data in the second row pertains to most designs.			

### 3. Calculations and Equations.

The purpose of this section is to calculate the power dissipation for the LVPECL output pair.

LVPECL output driver circuit and termination are shown in *Figure 6*.

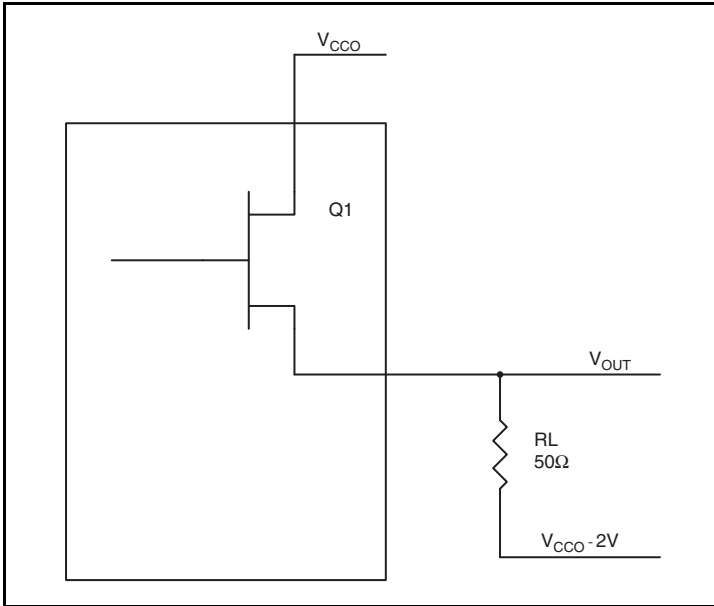

**Figure 6. LVPECL Driver Circuit and Termination**

To calculate worst case power dissipation into the load, use the following equations which assume a 50Ω load, and a termination voltage of V<sub>CCO</sub> - 2V.

- For logic high, V<sub>OUT</sub> = V<sub>OH\_MAX</sub> = V<sub>CCO\_MAX</sub> - 0.9V  
(V<sub>CCO\_MAX</sub> - V<sub>OH\_MAX</sub>) = 0.9V
- For logic low, V<sub>OUT</sub> = V<sub>OL\_MAX</sub> = V<sub>CCO\_MAX</sub> - 1.7V  
(V<sub>CCO\_MAX</sub> - V<sub>OL\_MAX</sub>) = 1.7V

Pd<sub>H</sub> is power dissipation when the output drives high.

Pd<sub>L</sub> is the power dissipation when the output drives low.

$$Pd_H = [(V_{OH\_MAX} - (V_{CCO\_MAX} - 2V))/R_L] * (V_{CCO\_MAX} - V_{OH\_MAX}) = [(2V - (V_{CCO\_MAX} - V_{OH\_MAX}))/R_L] * (V_{CCO\_MAX} - V_{OH\_MAX}) = [(2V - 0.9V)/50\Omega] * 0.9V = \mathbf{19.8mW}$$

$$Pd_L = [(V_{OL\_MAX} - (V_{CCO\_MAX} - 2V))/R_L] * (V_{CCO\_MAX} - V_{OL\_MAX}) = [(2V - (V_{CCO\_MAX} - V_{OL\_MAX}))/R_L] * (V_{CCO\_MAX} - V_{OL\_MAX}) = [(2V - 1.7V)/50\Omega] * 1.7V = \mathbf{10.2mW}$$

Total Power Dissipation per output pair = Pd<sub>H</sub> + Pd<sub>L</sub> = **30mW**

## Reliability Information

**Table 7.  $\theta_{JA}$  vs. Air Flow Table for a 32 Lead LQFP**

$\theta_{JA}$ by Velocity			
Linear Feet per Minute	0	200	500
Single-Layer PCB, JEDEC Standard Test Boards	67.8°C/W	55.9°C/W	50.1°C/W
Multi-Layer PCB, JEDEC Standard Test Boards	47.9°C/W	42.1°C/W	39.4°C/W
<b>NOTE:</b> Most modern PCB designs use multi-layered boards. The data in the second row pertains to most designs.			

## Transistor Count

The transistor count for 85310I-11 is: 1034

# Package Outline and Package Dimensions

## Package Outline - Y Suffix for 32 Lead LQFP

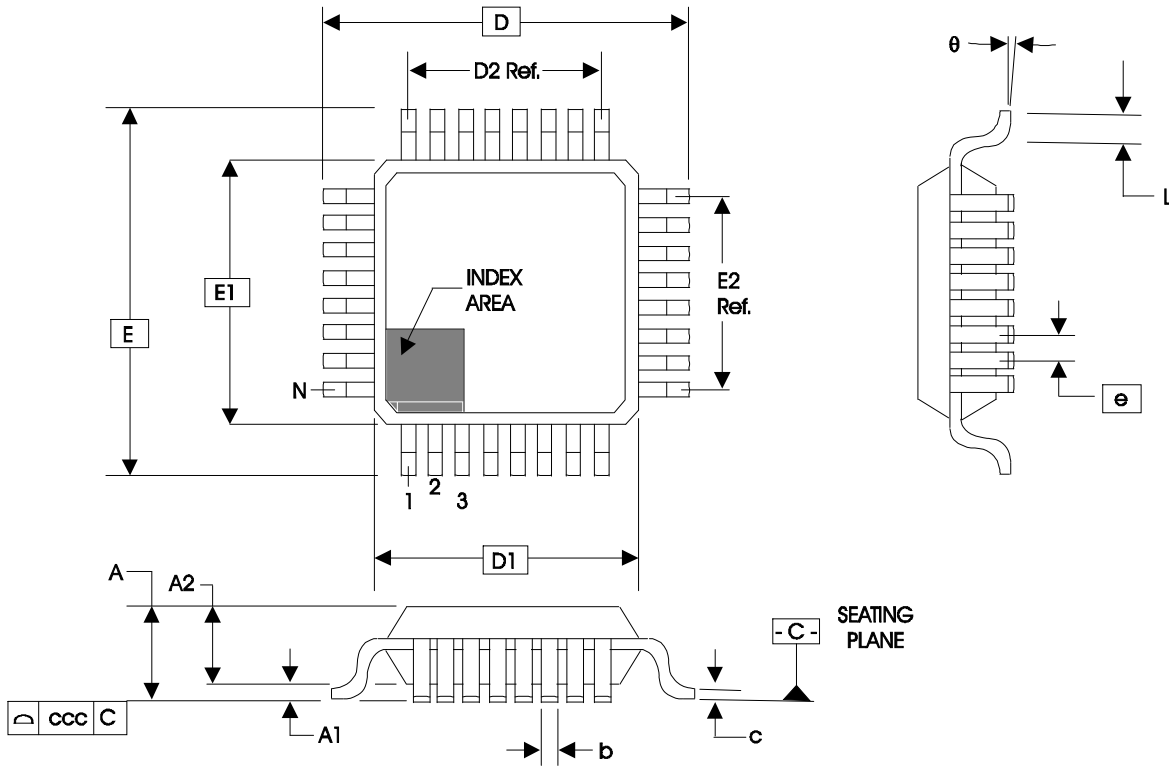

Table 8. Package Dimensions for 32 Lead LQFP

JEDEC Variation: BBA			
All Dimensions in Millimeters			
Symbol	Minimum	Nominal	Maximum
N	32		
A			1.60
A1	0.05		0.15
A2	1.35	1.40	1.45
b	0.30	0.37	0.45
c	0.09		0.20
D & E	9.00 Basic		
D1 & E1	7.00 Basic		
D2 & E2	5.60 Ref.		
e	0.80 Basic		
L	0.45	0.60	0.75
theta	0°		7°
ccc			0.10

Reference Document: JEDEC Publication 95, MS-026

## Ordering Information

**Table 9. Ordering Information**

Part/Order Number	Marking	Package	Shipping Packaging	Temperature
85310AYI-11LF	ICS5310AI11L	"Lead-Free" 32 Lead LQFP	Tray	-40°C to 85°C
85310AYI-11LFT	ICS5310AI11L	"Lead-Free" 32 Lead LQFP	Tape & Reel	-40°C to 85°C

NOTE: Parts that are ordered with an "LF" suffix to the part number are the Pb-Free configuration and are RoHS compliant.

## Revision History Sheet

Rev	Table	Page	Description of Change	Date
B	T5	5	AC Characteristics table - $t_{PD}$ row, revised value from 2.25ns Max. to 2.5ns Max.	4/29/02
B		9	Added <i>Termination for LVPECL Outputs.</i>	5/29/02
C	T4D	5	Added <i>LVPECL DC Characteristics table.</i> Changed part number from ICS85310-11 to 85310I-11 in title and all subsequent areas throughout the datasheet.	7/25/02
D	T4A	4 7	Power Supply table - increased max. value for $I_{EE}$ to 120mA from 30mA max. Power Considerations have re-adjusted to the increased $I_{EE}$ value.	10/23/02
E	T2 T5 T9	1 2 5 6 9 10 15	Features Section - added Additive Phase Jitter bullet and Lead-Free bullet. Pin Characteristics - changed $C_{IN}$ 4pF max. to 4pF typical. AC Characteristics Table - added Additive Phase Jitter spec. Added Additive Phase Jitter Section. Added Termination for 2.5V LVPECL Outputs. Added Differential Clock Input Interface. Ordering Information Table - added Lead-Free Part Number and Note.	7/7/05
F	T4D	5 11 - 12	LVPECL DC Characteristics Table -corrected $V_{OH}$ max. from $V_{CCO} - 1.0V$ to $V_{CCO} - 0.9V$ ; and $V_{SWING}$ max. from 0.85V to 1.0V. Power Considerations - corrected power dissipation to reflect $V_{OH}$ max in Table 4D.	4/11/07
F	T4C T5 T9	4 5 8 10 16	Differential DC Characteristics Table -updated NOTES. AC Characteristics Table - added thermal note. Updated <i>Wiring the Differential Input to Accept Single-ended Levels</i> section. Updated Figure 4A & 4B. Ordering Information Table - corrected lead-free marking. Converted datasheet format.	6/9/10
F	T9	16	Ordering Information - removed leaded devices. Updated data sheet format.	7/8/15



**Corporate Headquarters**  
6024 Silver Creek Valley Road  
San Jose, CA 95138 USA

**Sales**  
1-800-345-7015 or 408-284-8200  
Fax: 408-284-2775  
www.IDT.com

**Tech Support**  
email: [clocks@idt.com](mailto:clocks@idt.com)

DISCLAIMER Integrated Device Technology, Inc. (IDT) and its subsidiaries reserve the right to modify the products and/or specifications described herein at any time and at IDT's sole discretion. All information in this document, including descriptions of product features and performance, is subject to change without notice. Performance specifications and the operating parameters of the described products are determined in the independent state and are not guaranteed to perform the same way when installed in customer products. The information contained herein is provided without representation or warranty of any kind, whether express or implied, including, but not limited to, the suitability of IDT's products for any particular purpose, an implied warranty of merchantability, or non-infringement of the intellectual property rights of others. This document is presented only as a guide and does not convey any license under intellectual property rights of IDT or any third parties.

IDT's products are not intended for use in applications involving extreme environmental conditions or in life support systems or similar devices where the failure or malfunction of an IDT product can be reasonably expected to significantly affect the health or safety of users. Anyone using an IDT product in such a manner does so at their own risk, absent an express, written agreement by IDT.

While the information presented herein has been checked for both accuracy and reliability, Integrated Device Technology (IDT) assumes no responsibility for either its use or for the infringement of any patents or other rights of third parties, which would result from its use. No other circuits, patents, or licenses are implied. This product is intended for use in normal commercial applications. Any other applications, such as those requiring extended temperature ranges, high reliability or other extraordinary environmental requirements are not recommended without additional processing by IDT. IDT reserves the right to change any circuitry or specifications without notice. IDT does not authorize or warrant any IDT product for use in life support devices or critical medical instruments.

Integrated Device Technology, IDT and the IDT logo are registered trademarks of IDT. Product specification subject to change without notice. Other trademarks and service marks used herein, including protected names, logos and designs, are the property of IDT or their respective third party owners.

Copyright ©2015 Integrated Device Technology, Inc.. All rights reserved.

## IMPORTANT NOTICE AND DISCLAIMER

RENESAS ELECTRONICS CORPORATION AND ITS SUBSIDIARIES (“RENESAS”) PROVIDES TECHNICAL SPECIFICATIONS AND RELIABILITY DATA (INCLUDING DATASHEETS), DESIGN RESOURCES (INCLUDING REFERENCE DESIGNS), APPLICATION OR OTHER DESIGN ADVICE, WEB TOOLS, SAFETY INFORMATION, AND OTHER RESOURCES “AS IS” AND WITH ALL FAULTS, AND DISCLAIMS ALL WARRANTIES, EXPRESS OR IMPLIED, INCLUDING, WITHOUT LIMITATION, ANY IMPLIED WARRANTIES OF MERCHANTABILITY, FITNESS FOR A PARTICULAR PURPOSE, OR NON-INFRINGEMENT OF THIRD-PARTY INTELLECTUAL PROPERTY RIGHTS.

These resources are intended for developers who are designing with Renesas products. You are solely responsible for (1) selecting the appropriate products for your application, (2) designing, validating, and testing your application, and (3) ensuring your application meets applicable standards, and any other safety, security, or other requirements. These resources are subject to change without notice. Renesas grants you permission to use these resources only to develop an application that uses Renesas products. Other reproduction or use of these resources is strictly prohibited. No license is granted to any other Renesas intellectual property or to any third-party intellectual property. Renesas disclaims responsibility for, and you will fully indemnify Renesas and its representatives against, any claims, damages, costs, losses, or liabilities arising from your use of these resources. Renesas' products are provided only subject to Renesas' Terms and Conditions of Sale or other applicable terms agreed to in writing. No use of any Renesas resources expands or otherwise alters any applicable warranties or warranty disclaimers for these products.

(Disclaimer Rev.1.01 Jan 2024)

### Corporate Headquarters

TOYOSU FORESIA, 3-2-24 Toyosu,  
Koto-ku, Tokyo 135-0061, Japan  
[www.renesas.com](http://www.renesas.com)

### Trademarks



Renesas and the Renesas logo are trademarks of Renesas Electronics Corporation. All trademarks and registered trademarks are the property of their respective owners.

### Contact Information

For further information on a product, technology, the most up-to-date version of a document, or your nearest sales office, please visit [www.renesas.com/contact-us/](http://www.renesas.com/contact-us/).

## Looking for pricing, stock, or lifecycle information?

Click below to explore more details on WIN SOURCE:

-  [View 85310AYI-11LF on WIN SOURCE](#)
-  [Renesas Electronics America](#) Information

## Optimize Your Supply Chain with WIN SOURCE Solutions

-  Global Sourcing Solution
-  Obsolete Management
-  Cost Control Management
-  Shortage Management
-  Alternative Solution
-  Excess Inventory Management