



**THE DATASHEET OF  
841S104EGILF**



## General Description

The ICS841S104I is a PLL-based clock synthesizer specifically designed for PCI\_Express™ Clock applications. This device generates a 100MHz differential HCSL clock from an input reference of 25MHz. The input reference may be derived from an external source or by the addition of a 25MHz crystal to the on-chip crystal oscillator. An external reference is applied to the XTAL\_IN pin with the XTAL\_OUT pin left floating. The device offers spread spectrum clock output for reduced EMI applications. An I<sup>2</sup>C bus interface is used to enable or disable spread spectrum operation as well as select either a down spread value of -0.35% or -0.5%. The ICS841S104I is available in a lead-free 24-Lead package.

## Features

- Four 0.7V current mode differential HCSL output pairs
- Crystal oscillator interface: 25MHz
- Output frequency: 100MHz
- RMS phase jitter @ 100MHz (12kHz – 20MHz): 1.145ps (typical)
- Cycle-to-cycle jitter: 20ps (maximum)
- I<sup>2</sup>C support with readback capabilities up to 400kHz
- Spread Spectrum for electromagnetic interference (EMI) reduction
- 3.3V operating supply mode
- -40°C to 85°C ambient operating temperature
- Available lead-free (RoHS 6) package
- PCI Express Gen 1, 2, 3 jitter compliant

## Block Diagram

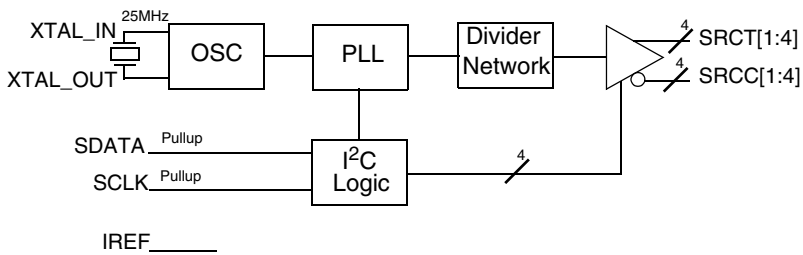

## Pin Assignment

SRCT3	1	24	SRCC4
SRCC3	2	23	SRCT4
V <sub>SS</sub>	3	22	V <sub>DD</sub>
V <sub>DD</sub>	4	21	SDATA
SRCT2	5	20	SCLK
SRCC2	6	19	XTAL_OUT
SRCT1	7	18	XTAL_IN
SRCC1	8	17	V <sub>DD</sub>
V <sub>SS</sub>	9	16	V <sub>SS</sub>
V <sub>DD</sub>	10	15	nc
V <sub>SS</sub>	11	14	V <sub>DDA</sub>
IREF	12	13	V <sub>SS</sub>

**ICS841S104I**  
**24-Lead TSSOP**  
**4.4mm x 7.8mm x 0.925mm package body**  
**G Package**  
**Top View**

**Table 1. Pin Descriptions**

Number	Name	Type		Description
1, 2	SRCT3, SRCC3	Output		Differential output pair. HCSL interface levels.
3, 9, 11, 13, 16	V <sub>SS</sub>	Power		Power supply ground.
4, 10, 17, 22	V <sub>DD</sub>	Power		Positive supply pins.
5, 6	SRCT2, SRCC2	Output		Differential output pair. HCSL interface levels.
7, 8	SRCT1, SRCC1	Output		Differential output pair. HCSL interface levels.
12	IREF	Input		An external fixed precision resistor (475Ω) from this pin to ground provides a reference current used for differential current-mode SRCCx, SRCTx clock outputs.
14	V <sub>DDA</sub>	Power		Analog supply for PLL.
15	nc	Unused		No connect.
18, 19	XTAL_IN, XTAL_OUT	Input		Crystal oscillator interface. XTAL_IN is the input. XTAL_OUT is the output.
20	SCLK	Input	Pullup	I <sup>2</sup> C compatible SCLK. This pin has an internal pullup resistor. LVCMOS/LVTTL interface levels.
21	SDATA	I/O	Pullup	I <sup>2</sup> C compatible SDATA. This pin has an internal pullup resistor. Open drain. LVCMOS/LVTTL interface levels.
23, 24	SRCT4, SRCC4	Output		Differential output pair. HCSL interface levels.

NOTE: *Pullup* refers to internal input resistors. See Table 2, *Pin Characteristics*, for typical values.

**Table 2. Pin Characteristics**

Symbol	Parameter	Test Conditions	Minimum	Typical	Maximum	Units
C <sub>IN</sub>	Input Capacitance			2		pF
R <sub>PULLUP</sub>	Input Pullup Resistor			51		kΩ

## Serial Data Interface

To enhance the flexibility and function of the clock synthesizer, a two-signal I<sup>2</sup>C serial interface is provided. Through the Serial Data Interface, various device functions, such as clock output buffers, can be individually enabled or disabled. The registers associated with the

serial interface initialize to their default settings upon power-up, and therefore, use of this interface is optional. Clock device register changes are normally made upon system initialization, if any are required.

## Data Protocol

The clock driver serial protocol accepts byte write, byte read, block write and block read operations from the controller. For block write/read operation, the bytes must be accessed in sequential order from lowest to highest byte (most significant bit first) with the ability to stop after any complete byte has been transferred. For byte write and byte read operations, the system controller can access individually

indexed bytes. The offset of the indexed byte is encoded in the command code, as described in Table 3A.

The block write and block read protocol is outlined in Table 3B, while Table 3C outlines the corresponding byte write and byte read protocol. The slave receiver address is 11010010 (D2h).

**Table 3A. Command Code Definition**

Bit	Description
7	0 = Block read or block write operation, 1 = Byte read or byte write operation
6:5	Chip select address, set to "00" to access device.
4:0	Byte offset for byte read or byte write operation. For block read or block write operations, these bits must be "00000"

**Table 3B. Block Read and Block Write Protocol**

Bit	Description = Block Write	Bit	Description = Block Read
1	Start	1	Start
2:8	Slave address - 7 bits	2:8	Slave address - 7 bits
9	Write	9	Write
10	Acknowledge from slave	10	Acknowledge from slave
11:18	Command Code - 8 bits	11:18	Command Code - 8 bits
19	Acknowledge from slave	19	Acknowledge from slave
20:27	Byte Count - 8 bits	20	Repeat start
28	Acknowledge from slave	21:27	Slave address - 7 bits
29:36	Data byte 1 - 8 bits	28	Read = 1
37	Acknowledge from slave	29	Acknowledge from slave
38:45	Data byte 2 - 8 bits	30:37	Byte Count from slave - 8 bits
46	Acknowledge from slave	38	Acknowledge
	Data Byte/Slave Acknowledges	39:46	Data Byte 1 from slave - 8 bits
	Data Byte N - 8 bits	47	Acknowledge
	Acknowledge from slave	48:55	Data Byte 2 from slave - 8 bits
	Stop	56	Acknowledge
			Data Bytes from Slave/Acknowledge
			Data Byte N from slave - 8 bits
			Not Acknowledge

**Table 3C. Byte Read and Byte Write Protocol**

Bit	Description = Byte Write	Bit	Description = Byte Read
1	Start	1	Start
2:8	Slave address - 7 bits	2:8	Slave address - 7 bits
9	Write	9	Write
10	Acknowledge from slave	10	Acknowledge from slave
11:18	Command Code - 8 bits	11:18	Command Code - 8 bits
19	Acknowledge from slave	19	Acknowledge from slave
20:27	Data Byte- 8 bits	20	Repeat start
28	Acknowledge from slave	21:27	Slave address - 7 bits
29	Stop	28	Read
		29	Acknowledge from slave
		30:37	Data from slave - 8 bits
		38	Not Acknowledge
		39	Stop

## Control Registers

**Table 3D. Byte 0: Control Register 0**

Bit	@Pup	Name	Description
7	0	Reserved	Reserved
6	1	SRC[T/C]4	SRC[T/C]4 Output Enable 0 = Disable (Hi-Z) 1 = Enable
5	1	SRC[T/C]3	SRC[T/C]3 Output Enable 0 = Disable (Hi-Z) 1 = Enable
4	1	SRC[T/C]2	SRC[T/C]2 Output Enable 0 = Disable (Hi-Z) 1 = Enable
3	1	SRC[T/C]1	SRC[T/C]1 Output Enable 0 = Disable (Hi-Z) 1 = Enable
2	1	Reserved	Reserved
1	0	Reserved	Reserved
0	0	Reserved	Reserved

NOTE: Pup denotes Power-up.

**Table 3E. Byte 1: Control Register 1**

Bit	@Pup	Name	Description
7	0	Reserved	Reserved
6	0	Reserved	Reserved
5	0	Reserved	Reserved
4	0	Reserved	Reserved
3	0	Reserved	Reserved
2	0	Reserved	Reserved
1	0	Reserved	Reserved
0	0	Reserved	Reserved

**Table 3F. Byte 2: Control Register 2**

Bit	@Pup	Name	Description
7	1	SRCT/C	Spread Spectrum Selection 0 = -0.35%, 1 = -0.5%
6	1	Reserved	Reserved
5	1	Reserved	Reserved
4	0	Reserved	Reserved
3	1	Reserved	Reserved
2	0	SRC	SRC Spread Spectrum Enable 0 = Spread Off, 1 = Spread On
1	1	Reserved	Reserved
0	0	Reserved	Reserved

**Table 3G. Byte 3: Control Register 3**

Bit	@Pup	Name	Description
7	1	Reserved	Reserved
6	0	Reserved	Reserved
5	1	Reserved	Reserved
4	0	Reserved	Reserved
3	1	Reserved	Reserved
2	1	Reserved	Reserved
1	1	Reserved	Reserved
0	1	Reserved	Reserved

**Table 3H. Byte 4: Control Register 4**

Bit	@Pup	Name	Description
7	0	Reserved	Reserved
6	0	Reserved	Reserved
5	0	Reserved	Reserved
4	0	Reserved	Reserved
3	0	Reserved	Reserved
2	0	Reserved	Reserved
1	0	Reserved	Reserved
0	1	Reserved	Reserved

**Table 3I. Byte 5: Control Register 5**

Bit	@Pup	Name	Description
7	0	Reserved	Reserved
6	0	Reserved	Reserved
5	0	Reserved	Reserved
4	0	Reserved	Reserved
3	0	Reserved	Reserved
2	0	Reserved	Reserved
1	0	Reserved	Reserved
0	0	Reserved	Reserved

**Table 3J. Byte 6: Control Register 6**

Bit	@Pup	Name	Description
7	0	TEST_SEL	REF/N or Hi-Z Select 0 = Hi-Z, 1 = REF/N
6	0	TEST_MODE	TEST Clock Mode Entry Control 0 = Normal Operation, 1 = REF/N or Hi-Z Mode
5	0	Reserved	Reserved
4	1	Reserved	Reserved
3	0	Reserved	Reserved
2	0	Reserved	Reserved
1	1	Reserved	Reserved
0	1	Reserved	Reserved

NOTE: Pup denotes Power-up.

**Table 3K. Byte 7: Control Register 7**

Bit	@Pup	Name	Description
7	0		Revision Code Bit 3
6	0		Revision Code Bit 2
5	0		Revision Code Bit 1
4	0		Revision Code Bit 0
3	0		Vendor ID Bit 3
2	0		Vendor ID Bit 2
1	0		Vendor ID Bit 1
0	1		Vendor ID Bit 0

## Absolute Maximum Ratings

NOTE: Stresses beyond those listed under *Absolute Maximum Ratings* may cause permanent damage to the device. These ratings are stress specifications only. Functional operation of product at these conditions or any conditions beyond those listed in the *DC Characteristics* or *AC Characteristics* is not implied. Exposure to absolute maximum rating conditions for extended periods may affect product reliability.

Item	Rating
Supply Voltage, $V_{DD}$	4.6V
Inputs, $V_I$ XTAL_IN Other Inputs	0V to $V_{DD}$ -0.5V to $V_{DD} + 0.5V$
Outputs, $V_O$	-0.5V to $V_{DD} + 0.5V$
Package Thermal Impedance, $\theta_{JA}$	77.5°C/W (0 mps)
Storage Temperature, $T_{STG}$	-65°C to 150°C

## DC Electrical Characteristics

**Table 4A. Power Supply DC Characteristics,  $V_{DD} = 3.3V \pm 5\%$ ,  $T_A = -40^\circ C$  to  $85^\circ C$** 

Symbol	Parameter	Test Conditions	Minimum	Typical	Maximum	Units
$V_{DD}$	Positive Supply Voltage		3.135	3.3	3.465	V
$V_{DDA}$	Analog Supply Voltage		$V_{DD} - 0.21$	3.3	$V_{DD}$	V
$I_{DD}$	Power Supply Current				80	mA
$I_{DDA}$	Analog Supply Current				21	mA

**Table 4B. LVCMOS/LVTTL DC Characteristics,  $V_{DD} = 3.3V \pm 5\%$ ,  $T_A = -40^{\circ}C$  to  $85^{\circ}C$** 

Symbol	Parameter	Test Conditions	Minimum	Typical	Maximum	Units
$V_{IH}$	Input High Voltage		2.2		$V_{DD} + 0.3$	V
$V_{IL}$	Input Low Voltage		-0.3		0.8	V
$I_{IH}$	Input High Current	SDATA, SCLK $V_{DD} = V_{IN} = 3.465V$			10	$\mu A$
$I_{IL}$	Input Low Current	SDATA, SCLK $V_{DD} = 3.465V, V_{IN} = 0V$	-150			$\mu A$

**Table 5. Crystal Characteristics**

Parameter	Test Conditions	Minimum	Typical	Maximum	Units
Mode of Oscillation		Fundamental			
Frequency			25		MHz
Equivalent Series Resistance (ESR)				50	$\Omega$
Shunt Capacitance				7	pF

NOTE: Characterized using an 18pF parallel resonant crystal.

## AC Electrical Characteristics

**Table 6A. PCI Express Jitter Specifications,  $V_{DD} = 3.3V \pm 5\%$ ,  $T_A = -40^{\circ}C$  to  $85^{\circ}C$** 

Parameter	Symbol	Test Conditions	Minimum	Typical	Maximum	PCIe Industry Specification	Units
$t_j$ (PCIe Gen 1)	Phase Jitter Peak-to-Peak; NOTE 1, 4	$f = 100MHz, 25MHz$ Crystal Input Evaluation Band: 0Hz - Nyquist (clock frequency/2)		13.8	21	86	ps
$t_{REFCLK\_HF\_RMS}$ (PCIe Gen 2)	Phase Jitter RMS; NOTE 2, 4	$f = 100MHz, 25MHz$ Crystal Input High Band: 1.5MHz - Nyquist (clock frequency/2)		1.34	3.03	3.1	ps
$t_{REFCLK\_LF\_RMS}$ (PCIe Gen 2)	Phase Jitter RMS; NOTE 2, 4	$f = 100MHz, 25MHz$ Crystal Input Low Band: 10kHz - 1.5MHz		0.18	0.3	3.0	ps
$t_{REFCLK\_RMS}$ (PCIe Gen 3)	Phase Jitter RMS; NOTE 3, 4	$f = 100MHz, 25MHz$ Crystal Input Evaluation Band: 0Hz - Nyquist (clock frequency/2)		0.28	0.71	0.8	ps

**NOTE:** Electrical parameters are guaranteed over the specified ambient operating temperature range, which is established when the device is mounted in a test socket with maintained transverse airflow greater than 500 lpm. The device will meet specifications after thermal equilibrium has been reached under these conditions. For additional information, refer to the *PCI Express Application Note* section in the datasheet.

**NOTE 1:** Peak-to-Peak jitter after applying system transfer function for the Common Clock Architecture. Maximum limit for PCI Express Gen 1 is 86ps peak-to-peak for a sample size of  $10^6$  clock periods.

**NOTE 2:** RMS jitter after applying the two evaluation bands to the two transfer functions defined in the Common Clock Architecture and reporting the worst case results for each evaluation band. Maximum limit for PCI Express Generation 2 is 3.1ps RMS for  $t_{REFCLK\_HF\_RMS}$  (High Band) and 3.0ps RMS for  $t_{REFCLK\_LF\_RMS}$  (Low Band).

**NOTE 3:** RMS jitter after applying system transfer function for the common clock architecture. This specification is based on the *PCI Express Base Specification Revision 0.7, October 2009* and is subject to change pending the final release version of the specification.

**NOTE 4:** This parameter is guaranteed by characterization. Not tested in production.

## AC Electrical Characteristics

Table 6B. AC Characteristics,  $V_{DD} = 3.3V \pm 5\%$ ,  $T_A = -40^\circ C$  to  $85^\circ C$

Symbol	Parameter	Test Conditions	Minimum	Typical	Maximum	Units
$f_{MAX}$	Output Frequency			100		MHz
$f_{REF}$	Reference frequency			25		MHz
$f_{jit}(\emptyset)$	Phase Jitter, RMS (Random); NOTE 1	25MHz crystal, $f = 100MHz$ , Integration Range: 12kHz – 20MHz		1.145		ps
$t_{sk(o)}$	Output Skew; NOTE 2, 3				40	ps
$f_{jit(cc)}$	Cycle-to-Cycle Jitter; NOTE 2	PLL Mode			20	ps
$t_L$	PLL Lock Time				50	ms
$F_M$	SSC Modulation Frequency; NOTE 4	25MHz Crystal	30	32	33.33	kHz
$SSC_{RED}$	Spectral Reduction; NOTE 4		-7	-10		dB
$V_{RB}$	Ring-back Voltage Margin; NOTE 5, 6		-100		100	mV
$V_{MAX}$	Absolute Max. Output Voltage; NOTE 7, 8				1150	mV
$V_{MIN}$	Absolute Min. Output Voltage; NOTE 7, 9		-300			mV
$V_{CROSS}$	Absolute Crossing Voltage; NOTE 7, 10, 11		250		550	mV
$\Delta V_{CROSS}$	Total Variation of $V_{CROSS}$ over all edges; NOTE 7, 10, 12				140	mV
	Rise/Fall Edge Rate; NOTE 7, 13	Measured between 150mV to +150mV	0.6		4.0	V/ns
odc	Output Duty Cycle		48		52	%

**NOTE:** Electrical parameters are guaranteed over the specified ambient operating temperature range, which is established when the device is mounted in a test socket with maintained transverse airflow greater than 500 lpm. The device will meet specifications after thermal equilibrium has been reached under these conditions.

**NOTE:** Characterized using a 25MHz quartz crystal.

**NOTE 1:** Refer to phase jitter plot.

**NOTE 2:** This parameter is defined in accordance with JEDEC Standard 65.

**NOTE 3:** Defined as skew between outputs at the same supply voltage and with equal load conditions. Measured at the differential cross points.

**NOTE 4:** Spread Spectrum clocking enabled.

**NOTE 5:** Measurement taken from differential waveform.

**NOTE 6:**  $T_{STABLE}$  is the time the differential clock must maintain a minimum  $\pm 150mV$  differential voltage after rising/falling edges before it is allowed to drop back into the  $V_{RB} \pm 100mV$  differential range.

**NOTE 7:** Measurement taken from single-ended waveform.

**NOTE 8:** Defined as the maximum instantaneous voltage including overshoot. See Parameter Measurement Information Section.

**NOTE 9:** Defined as the minimum instantaneous voltage including undershoot. See Parameter Measurement Information Section.

**NOTE 10:** Measured at crossing point where the instantaneous voltage value of the rising edge of SRCT equals the falling edge of SRCC.

**NOTE 11:** Refers to the total variation from the lowest crossing point to the highest, regardless of which edge is crossing. Refers to all crossing points for this measurement.

**NOTE 12:** Defined as the total variation of all crossing voltages of rising SRCT and falling SRCC, This is the maximum allowed variance in  $V_{cross}$  for any particular system.

**NOTE 13:** Measured from  $-150mV$  to  $+150mV$  on the differential waveform (SRCT minus SRCC). The signal must be monotonic through the measurement region for rise and fall time. The 300mV measurement window is centered on the differential zero crossing.

### Typical Phase Noise at 100MHz

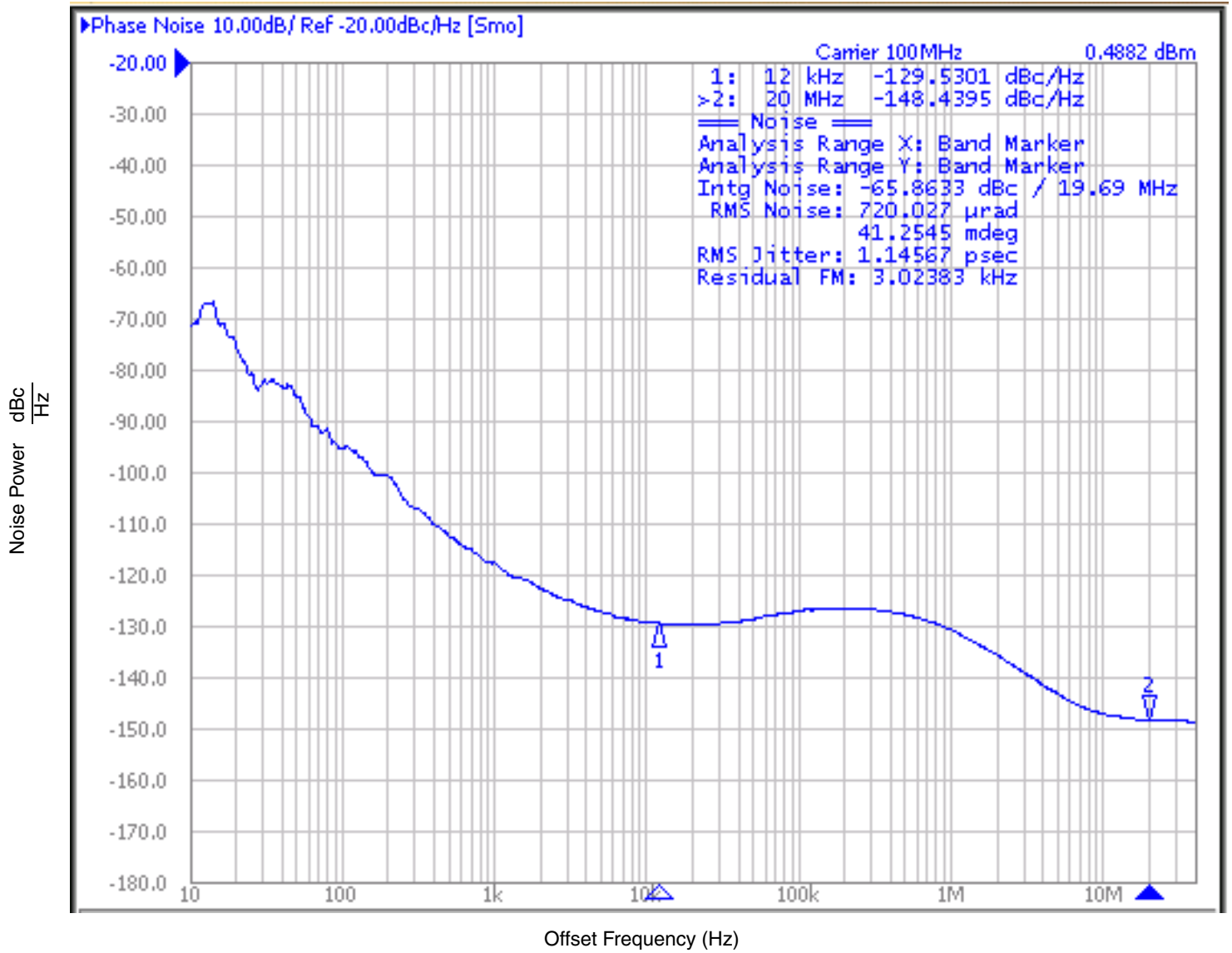

## Parameter Measurement Information

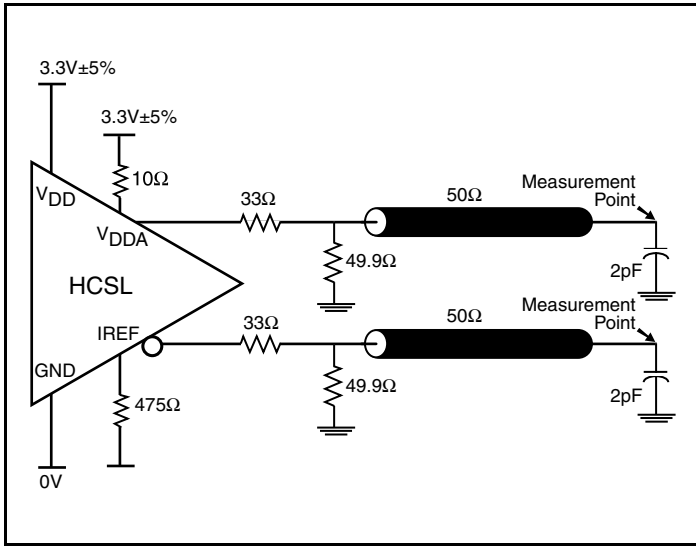

3.3V HCSL Output Load AC Test Circuit

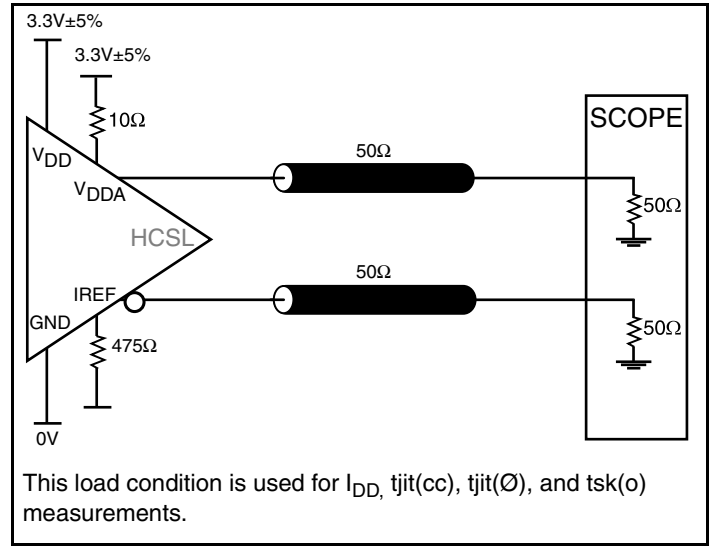

3.3V HCSL Output Load AC Test Circuit

This load condition is used for  $I_{DD}$ ,  $t_{jit}(cc)$ ,  $t_{jit}(o)$ , and  $t_{sk}(o)$  measurements.

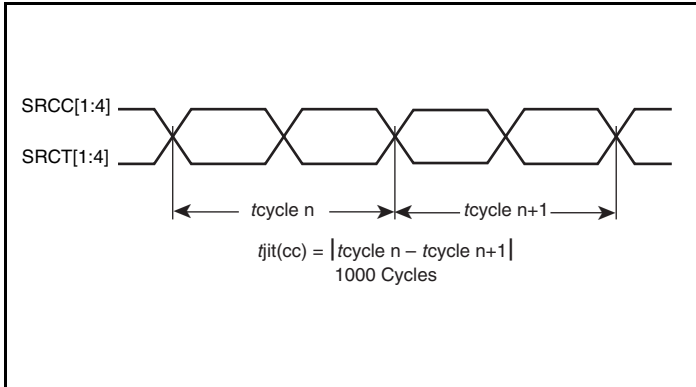

Cycle-to-Cycle Jitter

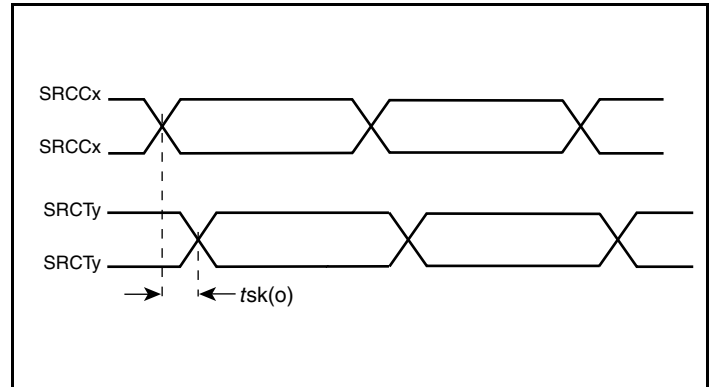

Output Skew

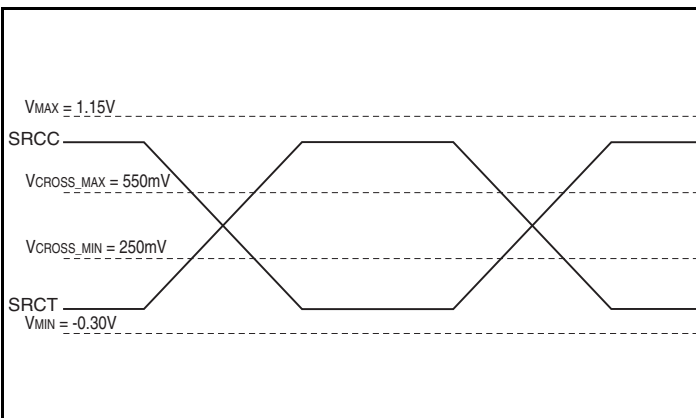

Single-ended Measurement Points for Absolute Cross Point and Swing

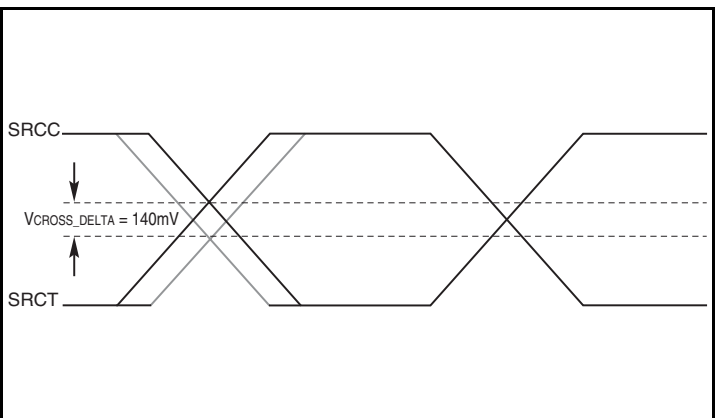

Single-ended Measurement Points for Delta Cross Point

Parameter Measurement Information, continued

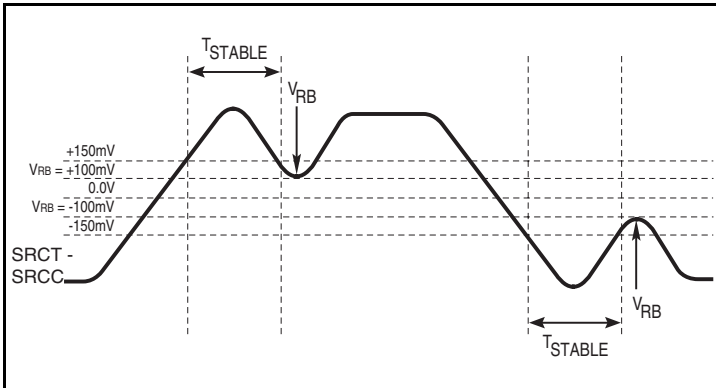

Differential Measurement Points for Ringback

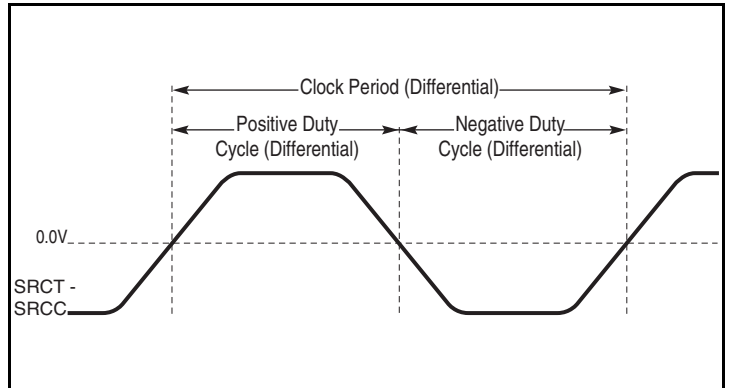

Differential Measurement Points for Duty Cycle/Period

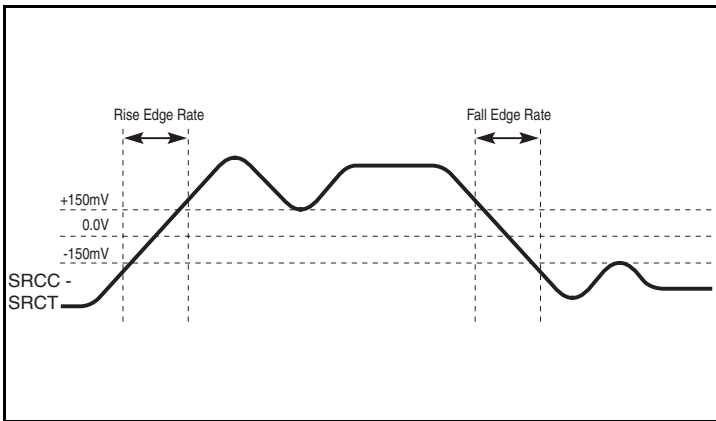

Differential Measurement Points for Rise/Fall Edge Rate

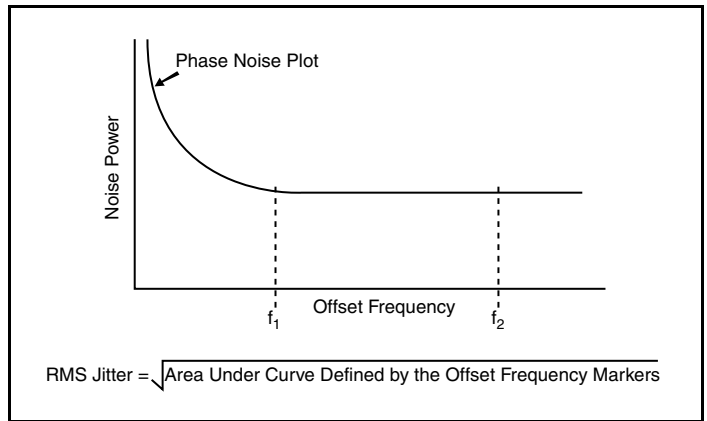

RMS Phase Jitter

## Application Information

### Power Supply Filtering Technique

As in any high speed analog circuitry, the power supply pins are vulnerable to random noise. To achieve optimum jitter performance, power supply isolation is required. The ICS841S104I provides separate power supplies to isolate any high switching noise from the outputs to the internal PLL.  $V_{DD}$  and  $V_{DDA}$  should be individually connected to the power supply plane through vias, and  $0.01\mu\text{F}$  bypass capacitors should be used for each pin. *Figure 1* illustrates this for a generic  $V_{DD}$  pin and also shows that  $V_{DDA}$  requires that an additional  $10\Omega$  resistor along with a  $10\mu\text{F}$  bypass capacitor be connected to the  $V_{DDA}$  pin.

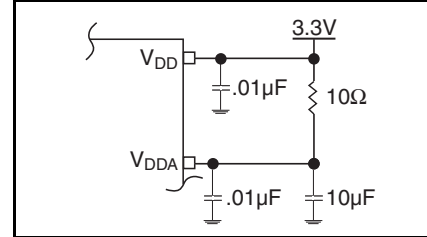

Figure 1. Power Supply Filtering

### Recommendations for Unused Input and Output Pins

#### Inputs:

##### LVC MOS Control Pins

All control pins have internal pullups; additional resistance is not required but can be added for additional protection. A  $1\text{k}\Omega$  resistor can be used.

#### Outputs:

##### Differential Outputs

All unused differential outputs can be left floating. We recommend that there is no trace attached. Both sides of the differential output pair should either be left floating or terminated.

## Crystal Input Interface

The ICS841S104I has been characterized with 18pF parallel resonant crystals. The capacitor values, C1 and C2, shown in *Figure 2* below were determined using a 25MHz, 18pF parallel resonant

crystal and were chosen to minimize the ppm error. The optimum C1 and C2 values can be slightly adjusted for different board layouts.

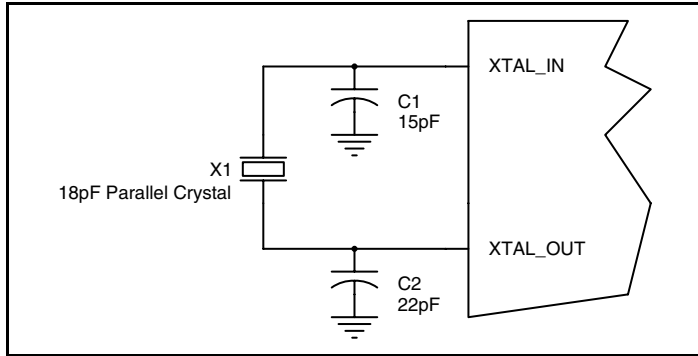
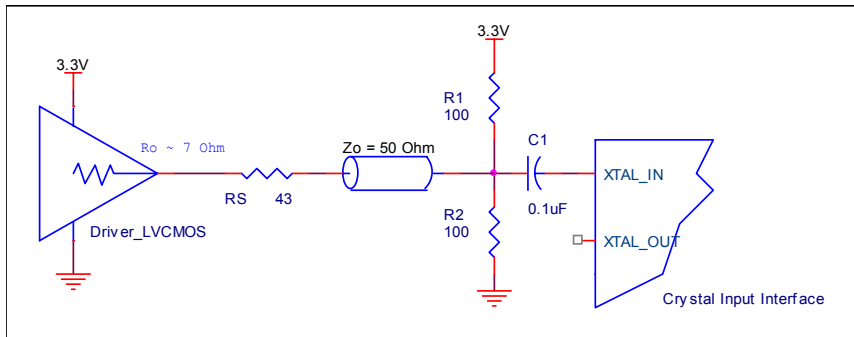

**Figure 2. Crystal Input Interface**

## Overdriving the XTAL Interface

The XTAL\_IN input can accept a single-ended LVCMOS signal through an AC coupling capacitor. A general interface diagram is shown in *Figure 3A*. The XTAL\_OUT pin can be left floating. The maximum amplitude of the input signal should not exceed 2V and the input edge rate can be as slow as 10ns. This configuration requires that the output impedance of the driver ( $R_o$ ) plus the series resistance ( $R_s$ ) equals the transmission line impedance. In addition,

matched termination at the crystal input will attenuate the signal in half. This can be done in one of two ways. First, R1 and R2 in parallel should equal the transmission line impedance. For most 50Ω applications, R1 and R2 can be 100Ω. This can also be accomplished by removing R1 and making R2 50Ω. By overdriving the crystal oscillator, the device will be functional, but note, the device performance is guaranteed by using a quartz crystal.



**Figure 3A. General Diagram for LVCMOS Driver to XTAL Input Interface**

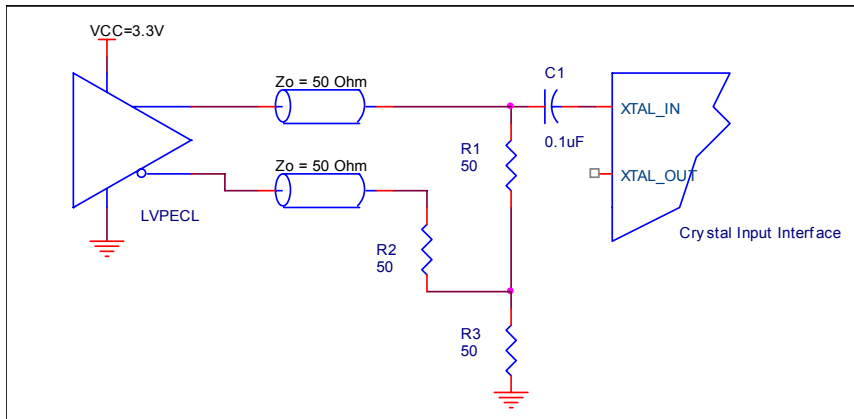

**Figure 3B. General Diagram for LVPECL Driver to XTAL Input Interface**

## Recommended Termination

Figure 4A is the recommended termination for applications which require the receiver and driver to be on a separate PCB. All traces should be  $50\Omega$  impedance.

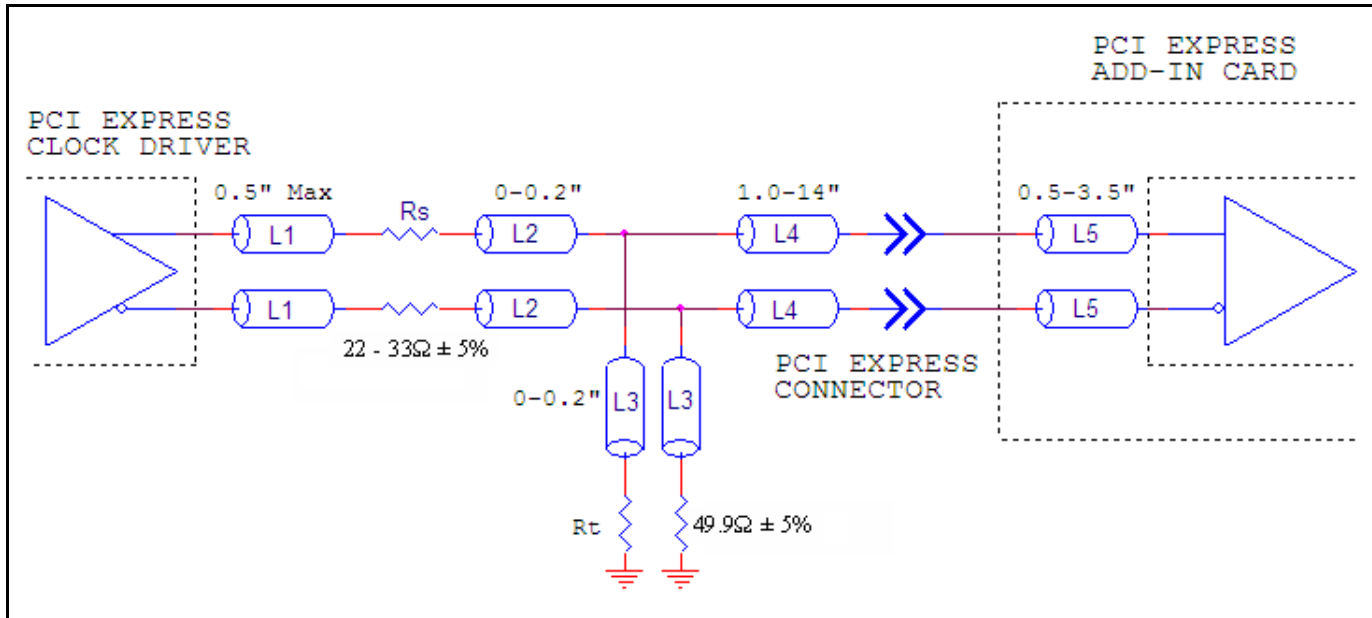

Figure 4A. Recommended Termination

Figure 4B is the recommended termination for applications which require a point to point connection and contain the driver and receiver on the same PCB. All traces should all be  $50\Omega$  impedance.

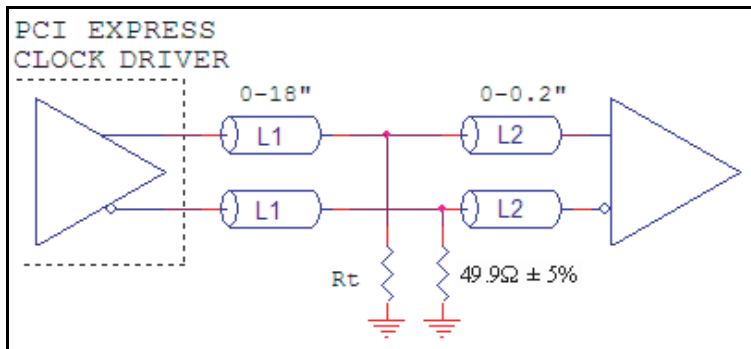

Figure 4B. Recommended Termination

## PCI Express Application Note

PCI Express jitter analysis methodology models the system response to reference clock jitter. The block diagram below shows the most frequently used *Common Clock Architecture* in which a copy of the reference clock is provided to both ends of the PCI Express Link.

In the jitter analysis, the transmit (Tx) and receive (Rx) serdes PLLs are modeled as well as the phase interpolator in the receiver. These transfer functions are called H1, H2, and H3 respectively. The overall system transfer function at the receiver is:

$$H_t(s) = H_3(s) \times [H_1(s) - H_2(s)]$$

The jitter spectrum seen by the receiver is the result of applying this system transfer function to the clock spectrum X(s) and is:

$$Y(s) = X(s) \times H_3(s) \times [H_1(s) - H_2(s)]$$

In order to generate time domain jitter numbers, an inverse Fourier Transform is performed on  $X(s) \times H_3(s) \times [H_1(s) - H_2(s)]$ .

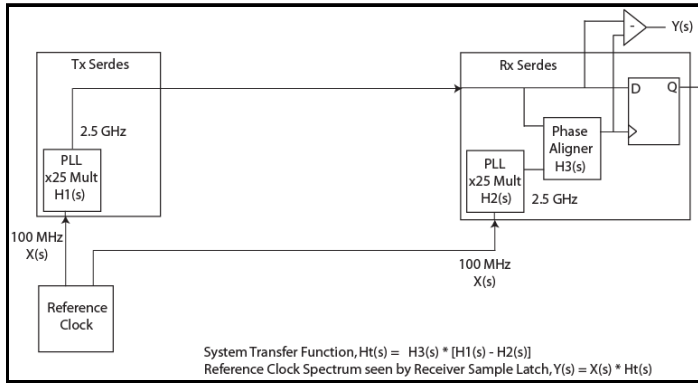

PCI Express Common Clock Architecture

For **PCI Express Gen 1**, one transfer function is defined and the evaluation is performed over the entire spectrum: DC to Nyquist (e.g. for a 100MHz reference clock: 0Hz – 50MHz) and the jitter result is reported in peak-peak.

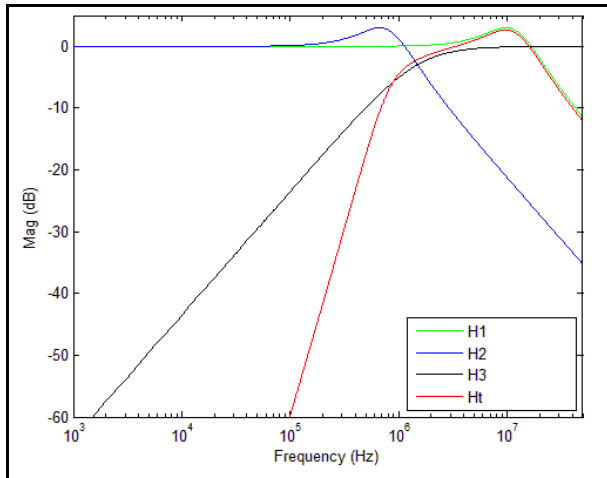

PCI Express Gen 1 Magnitude of Transfer Function

For **PCI Express Gen 2**, two transfer functions are defined with 2 evaluation ranges and the final jitter number is reported in rms. The two evaluation ranges for PCI Express Gen 2 are 10kHz – 1.5MHz (Low Band) and 1.5MHz – Nyquist (High Band). The plots show the individual transfer functions as well as the overall transfer function Ht.

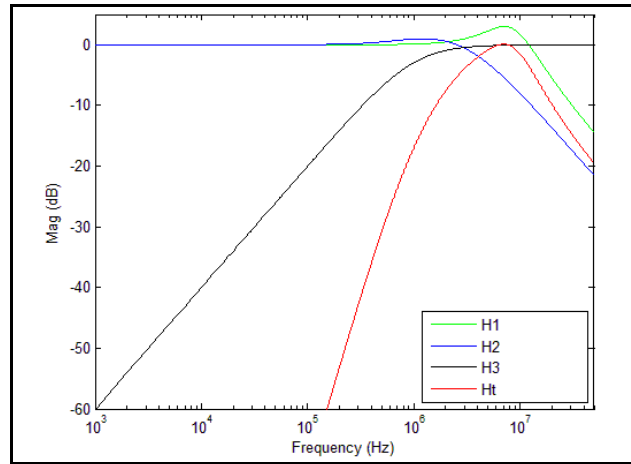

PCI Express Gen 2A Magnitude of Transfer Function

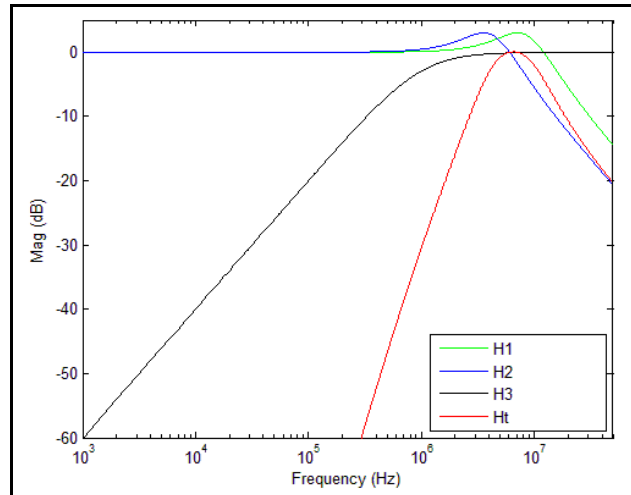

PCI Express Gen 2B Magnitude of Transfer Function

For **PCI Express Gen 3**, one transfer function is defined and the evaluation is performed over the entire spectrum. The transfer function parameters are different from Gen 1 and the jitter result is reported in RMS.

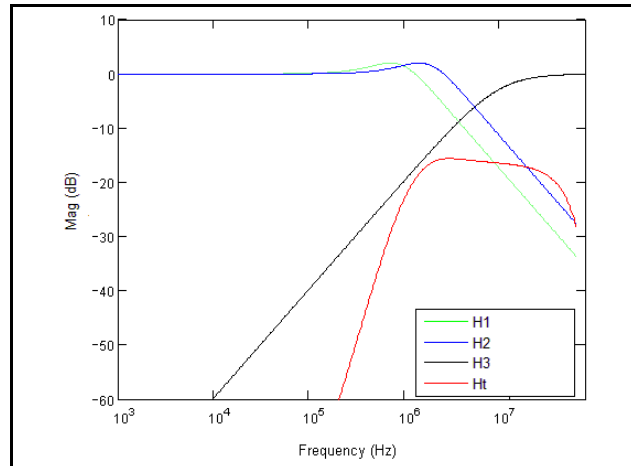

PCI Express Gen 3 Magnitude of Transfer Function

For a more thorough overview of PCI Express jitter analysis methodology, please refer to IDT Application Note *PCI Express Reference Clock Requirements*.

## Schematic Layout

Figure 5 shows an example of ICS841S104I application schematic. In this example, the device is operated at  $V_{DD} = 3.3V$ . The 18pF parallel resonant 25MHz crystal is used. The  $C1 = 18pF$  and  $C2 = 33pF$  are recommended for frequency accuracy. For different board

layouts, the  $C1$  and  $C2$  may be slightly adjusted for optimizing frequency accuracy. Two examples of HCSL termination are shown in this schematic. The decoupling capacitors should be located as close as possible to the power pin.

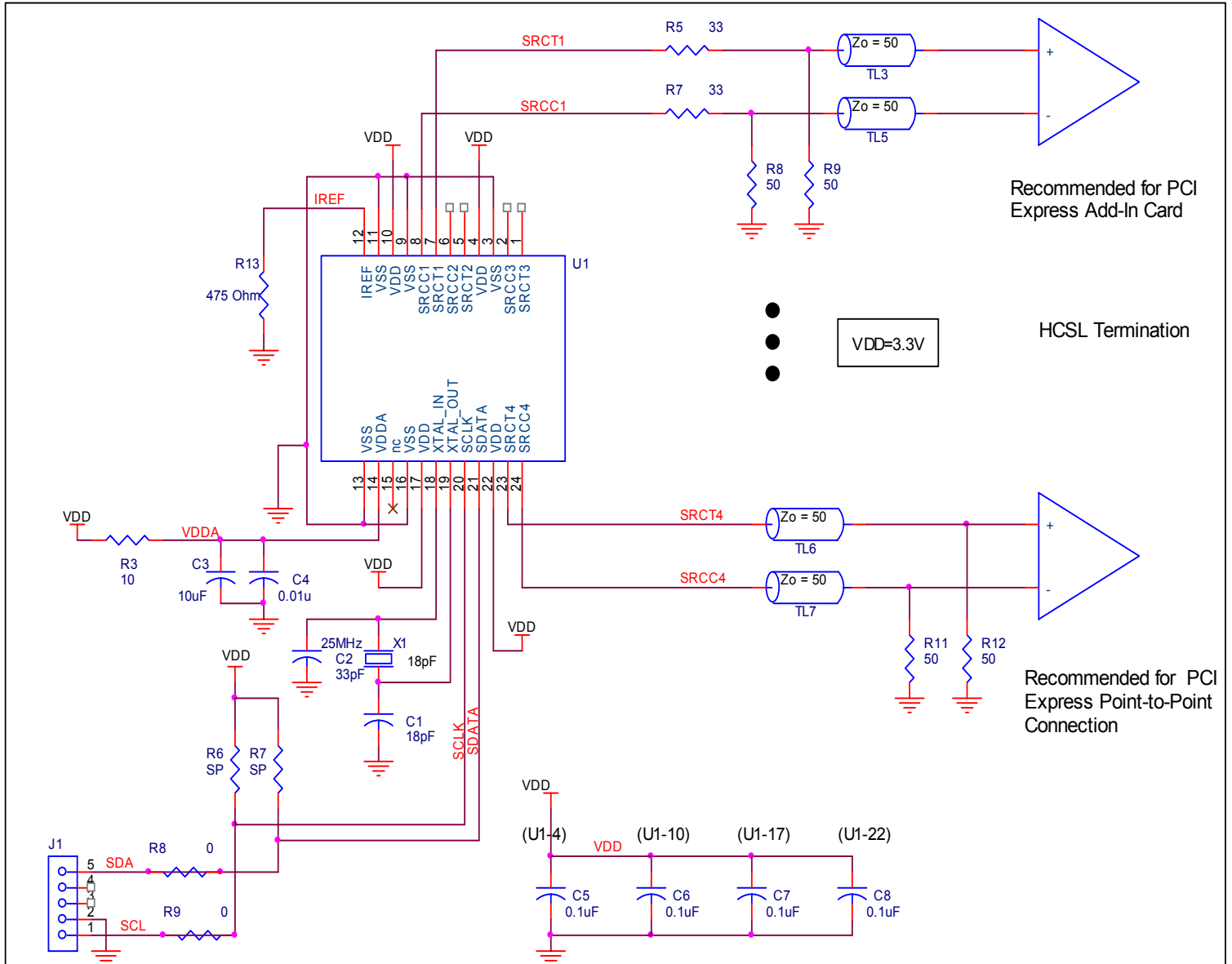

Figure 5. ICS841S104I Application Schematic.

## Spread Spectrum

Spread-spectrum clocking is a frequency modulation technique for EMI reduction. When spread-spectrum is enabled, a 32kHz triangle waveform is used with 0.5% down-spread from the nominal 100MHz clock frequency. An example of a triangle frequency modulation profile is shown in *Figure 6A* below.

The ICS841S104I triangle modulation frequency deviation is 0.5% down-spread from the nominal clock frequency. An example of the

amount of down spread relative to the nominal clock frequency can be seen in the frequency domain, as shown in *Figure 6B*. The ratio of this difference to the fundamental frequency is typically 0.5%. The resulting spectral reduction will be greater than 7dB, as shown in *Figure 2B*. It is important to note the ICS841S104I 7dB minimum spectral reduction is the component-specific EMI reduction, and will not necessarily be the same as the system EMI reduction.

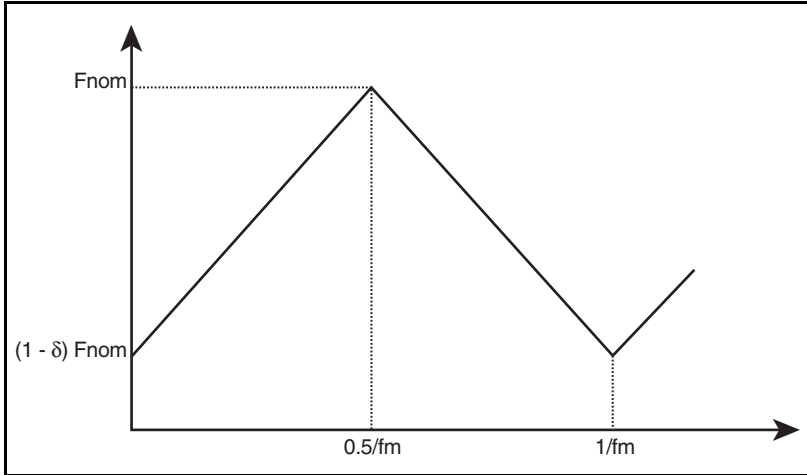

**Figure 6A. Triangle Frequency Modulation**

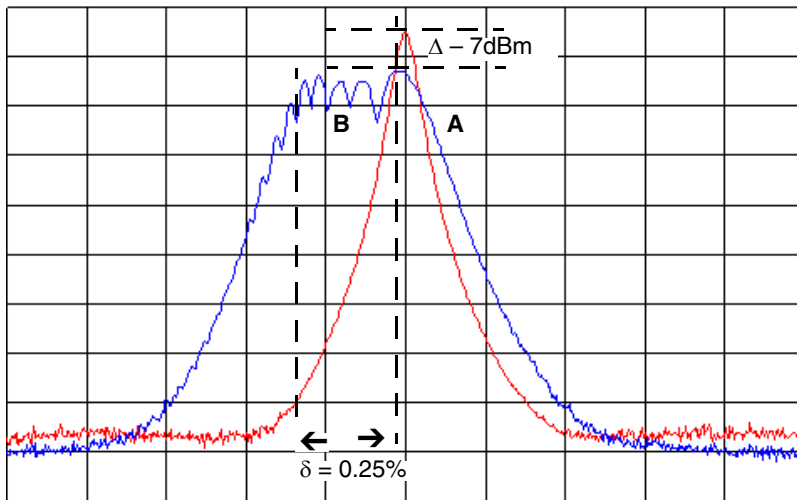

**Figure 6B. 100MHz Clock Output In Frequency Domain**

- (A) Spread-Spectrum OFF
- (B) Spread-Spectrum ON

## Power Considerations

This section provides information on power dissipation and junction temperature for the ICS841S104I. Equations and example calculations are also provided.

### 1. Power Dissipation.

The total power dissipation for the ICS841S104I is the sum of the core power plus the power dissipated in the load(s). The following is the power dissipation for  $V_{DD} = 3.3V + 5\% = 3.465V$ , which gives worst case results.

NOTE: Please refer to Section 3 for details on calculating power dissipated in the load.

The maximum current at 85°C is as follows:

$$I_{DD\_MAX} = 77mA$$

$$I_{DDA\_MAX} = 20mA$$

- Power (core)<sub>MAX</sub> =  $V_{DD\_MAX} * (I_{DD\_MAX} + I_{DDA\_MAX}) = 3.465V * (77mA + 20mA) = 336.105mW$
- Power (outputs)<sub>MAX</sub> = **44.5mW/Loaded Output pair**  
If all outputs are loaded, the total power is  $4 * 44.5mW = 178mW$

$$\text{Total Power}_{MAX} = 336.105mW + 178mW = 514.105mW$$

### 2. Junction Temperature.

Junction temperature,  $T_j$ , is the temperature at the junction of the bond wire and bond pad directly affects the reliability of the device. The maximum recommended junction temperature is 125°C. Limiting the internal transistor junction temperature,  $T_j$ , to 125°C ensures that the bond wire and bond pad temperature remains below 125°C.

The equation for  $T_j$  is as follows:  $T_j = \theta_{JA} * Pd_{total} + T_A$

$T_j$  = Junction Temperature

$\theta_{JA}$  = Junction-to-Ambient Thermal Resistance

$Pd_{total}$  = Total Device Power Dissipation (example calculation is in section 1 above)

$T_A$  = Ambient Temperature

In order to calculate junction temperature, the appropriate junction-to-ambient thermal resistance  $\theta_{JA}$  must be used. Assuming no air flow and a multi-layer board, the appropriate value is 77.5°C/W per Table 7 below.

Therefore,  $T_j$  for an ambient temperature of 85°C with all outputs switching is:

$$85^\circ C + 0.514W * 77.5^\circ C/W = 124.8^\circ C. \text{ This is below the limit of } 125^\circ C.$$

This calculation is only an example.  $T_j$  will obviously vary depending on the number of loaded outputs, supply voltage, air flow and the type of board (multi-layer).

**Table 7. Thermal Resistance  $\theta_{JA}$  for 24 Lead TSSOP, Forced Convection**

$\theta_{JA}$ vs. Air Flow			
Meters per Second	0	1	2.5
Multi-Layer PCB, JEDEC Standard Test Boards	77.5°C/W	73.2°C/W	71.0°C/W

### 3. Calculations and Equations.

The purpose of this section is to calculate power dissipation on the IC per HCSL output pair.

HCSL output driver circuit and termination are shown in *Figure 7*.

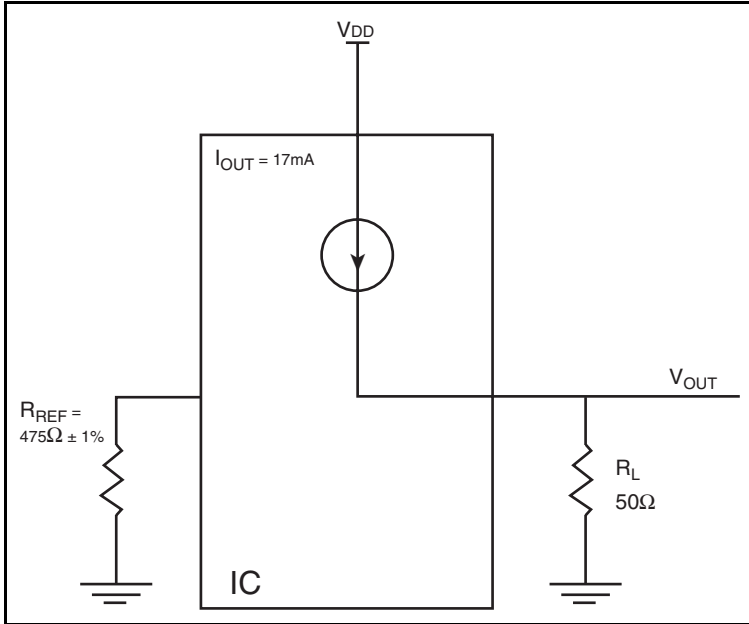

**Figure 7. HCSL Driver Circuit and Termination**

HCSL is a current steering output which sources a maximum of 17mA of current per output. To calculate worst case on-chip power dissipation, use the following equations which assume a 50Ω load to ground.

The highest power dissipation occurs when  $V_{DD\_MAX}$ .

$$\text{Power} = (V_{DD\_MAX} - V_{OUT}) * I_{OUT}$$

$$\text{since } V_{OUT} = I_{OUT} * R_L$$

$$= (V_{DD\_MAX} - I_{OUT} * R_L) * I_{OUT}$$

$$= (3.465V - 17mA * 50\Omega) * 17mA$$

Total Power Dissipation per output pair = **44.5mW**

## Reliability Information

Table 8.  $\theta_{JA}$  vs. Air Flow Table for a 24 Lead TSSOP

$\theta_{JA}$ vs. Air Flow			
Meters per Second	0	1	2.5
Multi-Layer PCB, JEDEC Standard Test Boards	77.5°C/W	73.2°C/W	71.0°C/W

## Transistor Count

The transistor count for ICS841S104I is: 11,775

## Package Outline and Package Dimensions

Package Outline - G Suffix for 24 Lead TSSOP

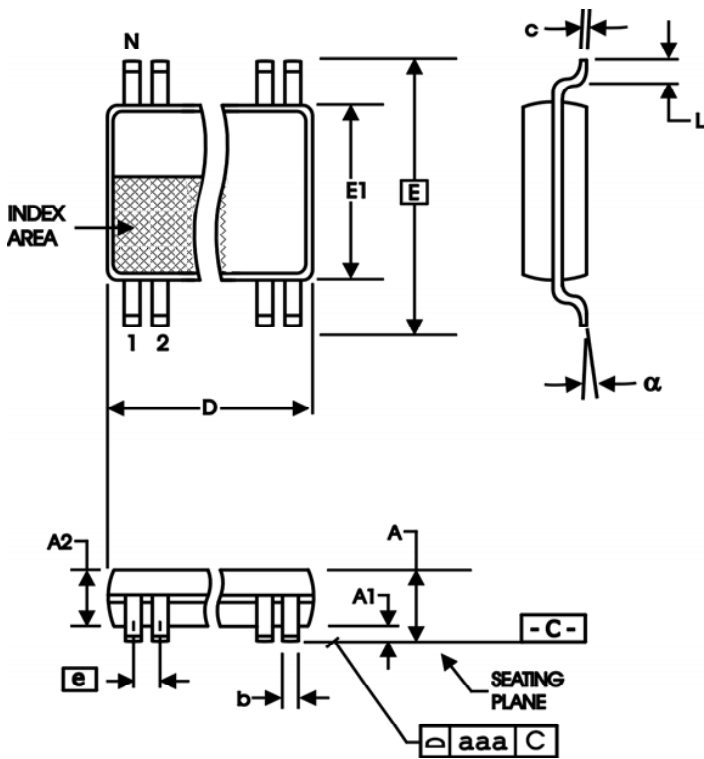

Table 9. Package Dimensions

All Dimensions in Millimeters		
Symbol	Minimum	Maximum
N	24	
A		1.20
A1	0.05	0.15
A2	0.80	1.05
b	0.19	0.30
c	0.09	0.20
D	7.70	7.90
E	6.40 Basic	
E1	4.30	4.50
e	0.65 Basic	
L	0.45	0.75
$\alpha$	0°	8°
aaa	0.10	

Reference Document: JEDEC Publication 95, MO-153

## Ordering Information

Table 10. Ordering Information

Part/Order Number	Marking	Package	Shipping Packaging	Temperature
841S104EGILF	ICS841S104EIL	"Lead-Free" 24 Lead TSSOP	Tube	-40°C to 85°C
841S104EGILFT	ICS841S104EIL	"Lead-Free" 24 Lead TSSOP	2500 Tape & Reel	-40°C to 85°C

NOTE: Parts that are ordered with a "LF" suffix to the part number are the Pb-Free configuration and are RoHS compliant.



## IMPORTANT NOTICE AND DISCLAIMER

RENESAS ELECTRONICS CORPORATION AND ITS SUBSIDIARIES (“RENESAS”) PROVIDES TECHNICAL SPECIFICATIONS AND RELIABILITY DATA (INCLUDING DATASHEETS), DESIGN RESOURCES (INCLUDING REFERENCE DESIGNS), APPLICATION OR OTHER DESIGN ADVICE, WEB TOOLS, SAFETY INFORMATION, AND OTHER RESOURCES “AS IS” AND WITH ALL FAULTS, AND DISCLAIMS ALL WARRANTIES, EXPRESS OR IMPLIED, INCLUDING, WITHOUT LIMITATION, ANY IMPLIED WARRANTIES OF MERCHANTABILITY, FITNESS FOR A PARTICULAR PURPOSE, OR NON-INFRINGEMENT OF THIRD-PARTY INTELLECTUAL PROPERTY RIGHTS.

These resources are intended for developers who are designing with Renesas products. You are solely responsible for (1) selecting the appropriate products for your application, (2) designing, validating, and testing your application, and (3) ensuring your application meets applicable standards, and any other safety, security, or other requirements. These resources are subject to change without notice. Renesas grants you permission to use these resources only to develop an application that uses Renesas products. Other reproduction or use of these resources is strictly prohibited. No license is granted to any other Renesas intellectual property or to any third-party intellectual property. Renesas disclaims responsibility for, and you will fully indemnify Renesas and its representatives against, any claims, damages, costs, losses, or liabilities arising from your use of these resources. Renesas' products are provided only subject to Renesas' Terms and Conditions of Sale or other applicable terms agreed to in writing. No use of any Renesas resources expands or otherwise alters any applicable warranties or warranty disclaimers for these products.

(Disclaimer Rev.1.01 Jan 2024)

### Corporate Headquarters

TOYOSU FORESIA, 3-2-24 Toyosu,  
Koto-ku, Tokyo 135-0061, Japan  
[www.renesas.com](http://www.renesas.com)

### Trademarks

Renesas and the Renesas logo are trademarks of Renesas Electronics Corporation. All trademarks and registered trademarks are the property of their respective owners.

### Contact Information

For further information on a product, technology, the most up-to-date version of a document, or your nearest sales office, please visit [www.renesas.com/contact-us/](http://www.renesas.com/contact-us/).

## Looking for pricing, stock, or lifecycle information?

Click below to explore more details on WIN SOURCE:

-  [View 841S104EGILF on WIN SOURCE](#)
-  [Renesas Electronics America](#) Information

## Optimize Your Supply Chain with WIN SOURCE Solutions

-  Global Sourcing Solution
-  Obsolete Management
-  Cost Control Management
-  Shortage Management
-  Alternative Solution
-  Excess Inventory Management