



THE DATASHEET OF
8344AYI-01LF



General Description

The ICS8344I-01 is a low voltage, low skew fanout buffer. The ICS8344I-01 has two selectable clock inputs. The CLKx, nCLKx pairs can accept most standard differential input levels. The ICS8344I-01 is designed to translate any differential signal level to LVCMOS/LVTTL levels. The low impedance LVCMOS/LVTTL outputs are designed to drive 50Ω series or parallel terminated transmission lines. The effective fanout can be increased to 48 by utilizing the ability of the outputs to drive two series terminated lines. Redundant clock applications can make use of the dual clock inputs which also facilitate board level testing. The clock enable is internally synchronized to eliminate runt pulses on the outputs during asynchronous assertion/deassertion of the clock enable pin. The outputs are driven low when disabled. The ICS8344I-01 is characterized at full 3.3V, full 2.5V and mixed 3.3V input and 2.5V output operating supply modes.

Guaranteed output and part-to-part skew characteristics make the ICS8344I-01 ideal for those clock distribution applications demanding well defined performance and repeatability.

Features

- Twenty-four LVCMOS/LVTTL outputs, 7Ω typical output impedance
- Two selectable differential CLKx, nCLKx inputs
- CLK0, nCLK0 and CLK1, nCLK1 pairs can accept the following input levels: LVDS, LVPECL, LVHSTL, HCSL
- Maximum output frequency: 100MHz
- Translates any single ended input signal to LVCMOS/LVTTL with resistor bias on nCLK input
- Synchronous clock enable
- Additive phase jitter, RMS: 0.21ps (typical)
- Output skew: 200ps (maximum)
- Part-to-part skew: 900ps (maximum)
- Bank skew: 180ps (maximum)
- Propagation delay: 5ns (maximum)
- Output supply modes:
Core/Output
3.3V/3.3V
2.5V/2.5V
3.3V/2.5V
- -40°C to 70°C ambient operating temperature
- Available in lead-free (RoHS 6) package

Block Diagram

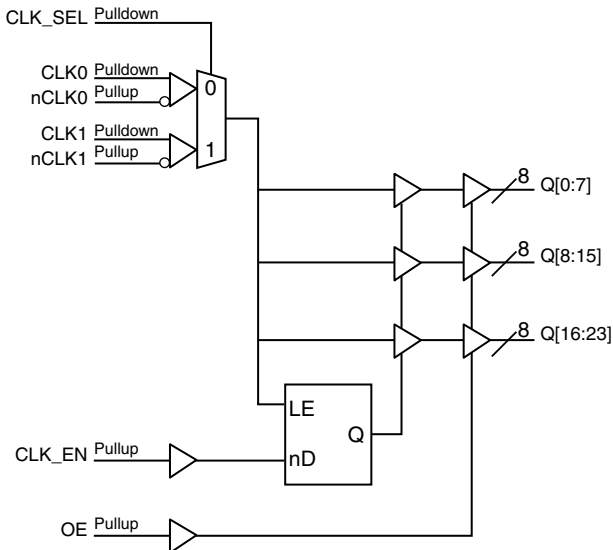

Pin Assignment

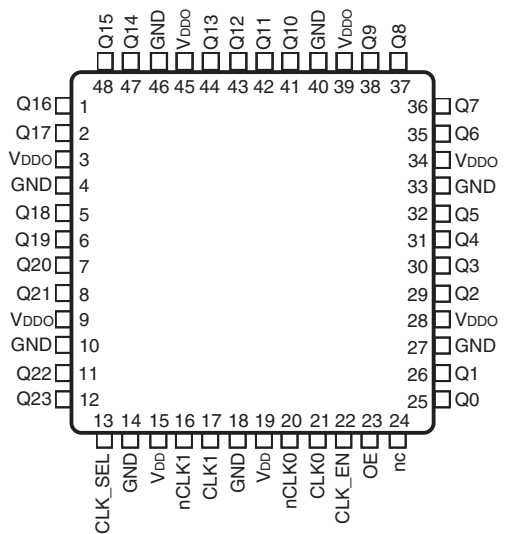

ICS8344I-01

48-Lead LQFP

7mm x 7mm x 1.4mm package body

Y Package

Top View

Table 1. Pin Descriptions

Number	Name	Type		Description
1, 2, 5, 6, 7, 8, 11, 12	Q16, Q17, Q18, Q19, Q20, Q21, Q22, Q23	Output		Single-ended clock outputs. 7Ω typical output Impedance. LVCMOS/LVTTL interface levels.
3, 9, 28, 34, 39, 45	V _{DDO}	Power		Output supply pins.
4, 10, 14, 18, 27, 33, 40, 46	GND	Power		Power supply ground.
13	CLK_SEL	Input	Pulldown	Clock select input. When HIGH, selects CLK1, nCLK inputs, When LOW, selects CLK0, nCLK0 inputs. LVCMOS / LVTTL interface levels.
15, 19	V _{DD}	Power		Power supply pins.
16	nCLK1	Input	Pullup	Inverting differential clock input.
17	CLK1	Input	Pulldown	Non-inverting differential clock input.
20	nCLK0	Input	Pullup	Inverting differential clock input.
21	CLK0	Input	Pulldown	Non-inverting differential clock input.
22	CLK_EN	Input	Pullup	Synchronizing control for enabling and disabling clock outputs. LVCMOS / LVTTL interface levels.
23	OE	Input	Pullup	Output enable. Controls enabling and disabling of outputs Q[0:23]. LVCMOS / LVTTL interface levels.
24	nc	Unused		No connect.
25, 26, 29, 30, 31, 32, 35, 36	Q0, Q1, Q2, Q3, Q4, Q5, Q6, Q7	Output		Single-ended clock outputs. 7Ω typical output Impedance. LVCMOS/LVTTL interface levels.
37, 38, 41, 42, 43, 44, 47, 48	Q8, Q9, Q10, Q11, Q12, Q13, Q14, Q15	Output		Single-ended clock outputs. 7Ω typical output Impedance. LVCMOS/LVTTL interface levels.

NOTE: Pullup and Pulldown refer to internal input resistors. See Table 2, *Pin Characteristics*, for typical values.

Table 2. Pin Characteristics

Symbol	Parameter	Test Conditions	Minimum	Typical	Maximum	Units
C _{IN}	Input Capacitance			4		pF
C _{PD}	Power Dissipation Capacitance (per output)	V _{DD} = V _{DDO} = 3.465V		23		pF
		V _{DD} = V _{DDO} = 2.625V		16		pF
R _{PULLUP}	Input Pullup Resistor			51		kΩ
R _{PULLDOWN}	Input Pulldown Resistor			51		kΩ
R _{OUT}	Output Impedance	V _{DDO} = 3.3V±5% or 2.5V±5%		7		Ω

Function Tables

Table 3A. Output Enable Function Table

Control Input		Outputs
OE	CLK_EN	Q[0:23]
0	X	High-Impedance
1	0	Disabled in Logic LOW state; NOTE 1
1	1	Enabled; NOTE 1

NOTE 1: The clock enable and disable function is synchronous to the falling edge of the selected reference clock.

Table 3A. Clock Select Function Table

Control Input	Clock	
CLK_SEL	CLK0, nCLK0	CLK1, nCLK1
0	Selected	De-selected
1	De-selected	Selected

Table 3C. Clock Input Function Table

Inputs			Outputs	Input to Output Mode	Polarity
OE	CLK0, CLK1	nCLK0, nCLK1	Q[0:23]		
1 (default)	0 (default)	1 (default)	LOW	Differential to Single-Ended	Non-Inverting
1	1	0	HIGH	Differential to Single-Ended	Non-Inverting
1	0	Biased; NOTE 1	LOW	Single-Ended to Single-Ended	Non-Inverting
1	1	Biased; NOTE 1	HIGH	Single-Ended to Single-Ended	Non-Inverting
1	Biased; NOTE 1	0	HIGH	Single-Ended to Single-Ended	Inverting
1	Biased; NOTE 1	1	LOW	Single-Ended to Single-Ended	Inverting

NOTE 1: Please refer to the Application Information Section, *Wiring the Differential Input to Accept Single-ended Levels*.

Absolute Maximum Ratings

NOTE: Stresses beyond those listed under *Absolute Maximum Ratings* may cause permanent damage to the device. These ratings are stress specifications only. Functional operation of product at these conditions or any conditions beyond those listed in the *DC Characteristics* or *AC Characteristics* is not implied. Exposure to absolute maximum rating conditions for extended periods may affect product reliability.

Item	Rating
Supply Voltage, V_{DD}	4.6V
Inputs, V_I	-0.5V to $V_{DD} + 0.5V$
Outputs, V_O	-0.5V to $V_{DDO} + 0.5V$
Package Thermal Impedance, θ_{JA}	53.9°C/W (0 mps)
Storage Temperature, T_{STG}	-65°C to 150°C

DC Electrical Characteristics

Table 4A. Power Supply DC Characteristics, $V_{DD} = V_{DDO} = 3.3V \pm 5\%$, or $V_{DD} = V_{DDO} = 2.5V \pm 5\%$, or $V_{DD} = 3.3V \pm 5\%$, $V_{DDO} = 2.5V \pm 5\%$, $T_A = -40^\circ\text{C}$ to 70°C

Symbol	Parameter	Test Conditions	Minimum	Typical	Maximum	Units
V_{DD}	Power Supply Voltage		3.135	3.3	3.465	V
			2.375	2.5	2.625	V
V_{DDO}	Output Supply Voltage		3.135	3.3	3.465	V
			2.375	2.5	2.625	V
I_{DD}	Power Supply Current				95	mA

Table 4B. LVCMOS/LVTTL DC Characteristics, $T_A = -40^\circ\text{C}$ to 70°C

Symbol	Parameter	Test Conditions	Minimum	Typical	Maximum	Units
V_{IH}	Input High Voltage	$V_{DD} = 3.465V$	2		3.8	V
		$V_{DD} = 2.625V$	2		2.9	V
V_{IL}	Input Low Voltage	$V_{DD} = 3.465V$	-0.3		0.8	V
		$V_{DD} = 2.625V$	-0.3		0.8	V
I_{IH}	Input High Current	OE, CLK_EN $V_{DD} = V_{IN} = 3.465V$ or $2.625V$			5	μA
		CLK_SEL $V_{DD} = V_{IN} = 3.465V$ or $2.625V$			150	μA
I_{IL}	Input Low Current	OE, CLK_EN $V_{DD} = 3.465V$ or $2.625V$, $V_{IN} = 0V$	-150			μA
		CLK_SEL $V_{DD} = 3.465V$ or $2.625V$, $V_{IN} = 0V$	-5			μA
V_{OH}	Output High Voltage	$V_{DDO} = 3.135V$, $I_{OH} = -36\text{mA}$	2.7			V
		$V_{DDO} = 2.375V$, $I_{OH} = -27\text{mA}$	1.9			V
V_{OL}	Output Low Voltage	$V_{DDO} = 3.135V$, $I_{OL} = 36\text{mA}$			0.5	V
		$V_{DDO} = 2.375V$, $I_{OL} = 27\text{mA}$			0.5	V

Table 4C. Differential DC Characteristics, $V_{DD} = V_{DDO} = 3.3V \pm 5\%$, or $V_{DD} = V_{DDO} = 2.5V \pm 5\%$, or $V_{DD} = 3.3V \pm 5\%$, $V_{DDO} = 2.5V \pm 5\%$, $T_A = -40^{\circ}C$ to $70^{\circ}C$

Symbol	Parameter	Test Conditions	Minimum	Typical	Maximum	Units
I_{IH}	Input High Current	nCLK0, nCLK1	$V_{DD} = V_{IN} = 3.465V$ or $2.625V$		5	μA
		CLK0, CLK1	$V_{DD} = V_{IN} = 3.465V$ or $2.625V$		150	μA
I_{IL}	Input Low Current	nCLK0, nCLK1	$V_{DD} = 3.465V$ or $2.625V$, $V_{IN} = 0V$	-150		μA
		CLK0, CLK1	$V_{DD} = 3.465V$ or $2.625V$, $V_{IN} = 0V$	-5		μA
V_{PP}	Peak-to-Peak Voltage; NOTE 1		0.3		1.3	V
V_{CMR}	Common Mode Input Voltage; NOTE 1, 2		0.9		2.0	V

NOTE 1: V_{IL} should not be less than $-0.3V$.

NOTE 2: Common mode input voltage is defined as V_{IH} .

AC Electrical Characteristics

Table 5. AC Characteristics, $V_{DD} = V_{DDO} = 3.3V \pm 5\%$, or $V_{DD} = V_{DDO} = 2.5V \pm 5\%$, or $V_{DD} = 3.3V \pm 5\%$, $V_{DDO} = 2.5V \pm 5\%$, $T_A = -40^{\circ}C$ to $70^{\circ}C$

Symbol	Parameter	Test Conditions	Minimum	Typical	Maximum	Units
f_{OUT}	Output Frequency				100	MHz
t_{PD}	Propagation Delay; NOTE 1	$f \leq 100MHz$	2.5		5	ns
t_{jit}	Buffer Additive Phase Jitter, RMS; refer to Additive Phase Jitter Section	100MHz, Integration Range: 12kHz – 20MHz		0.21		ps
$t_{sk(b)}$	Bank Skew; NOTE 2, 6	Q[0:7]	Measured on the rising edge of $V_{DDO}/2$		155	ps
		Q[8:15]			180	ps
		Q[16:23]			140	ps
$t_{sk(o)}$	Output Skew; NOTE 3, 6	Measured on the rising edge of $V_{DDO}/2$			200	ps
$t_{sk(pp)}$	Part-to-Part Skew; NOTE 4, 6	Measured on the rising edge of $V_{DDO}/2$			900	ps
t_R / t_F	Output Rise/Fall Time; NOTE 5	30% to 70%	200		800	ps
t_{EN}	Output Enable Time; NOTE 5	$f = 10MHz$			5	ns
t_{DIS}	Output Disable Time; NOTE 5	$f = 10MHz$			4	ns
odc	Output Duty Cycle	$f \leq 100MHz$	45		55	%

NOTE: Electrical parameters are guaranteed over the specified ambient operating temperature range, which is established when the device is mounted in a test socket with maintained transverse airflow greater than 500 lpm. The device will meet specifications after thermal equilibrium has been reached under these conditions.

NOTE: All parameters measured at $\leq 100MHz$ and V_{PP_typ} unless noted otherwise.

NOTE 1: Measured from the differential input crossing point to $V_{DDO}/2$.

NOTE 2: Defined as skew within a bank of outputs at the same voltages and with equal load conditions.

NOTE 3: Defined as skew across banks of outputs at the same supply voltages and with equal load conditions.

NOTE 4: Defined as between outputs at the same supply voltages and with equal load conditions. Measured at $V_{DDO}/2$.

NOTE 5: These parameters are guaranteed by characterization. Not tested in production.

NOTE 6: This parameter is defined in accordance with JEDEC Standard 65.

Additive Phase Jitter

The spectral purity in a band at a specific offset from the fundamental compared to the power of the fundamental is called the **dBc Phase Noise**. This value is normally expressed using a Phase noise plot and is most often the specified plot in many applications. Phase noise is defined as the ratio of the noise power present in a 1Hz band at a specified offset from the fundamental frequency to the power value of the fundamental. This ratio is expressed in decibels (dBm) or a ratio

of the power in the 1Hz band to the power in the fundamental. When the required offset is specified, the phase noise is called a **dBc** value, which simply means dBm at a specified offset from the fundamental. By investigating jitter in the frequency domain, we get a better understanding of its effects on the desired application over the entire time record of the signal. It is mathematically possible to calculate an expected bit error rate given a phase noise plot.

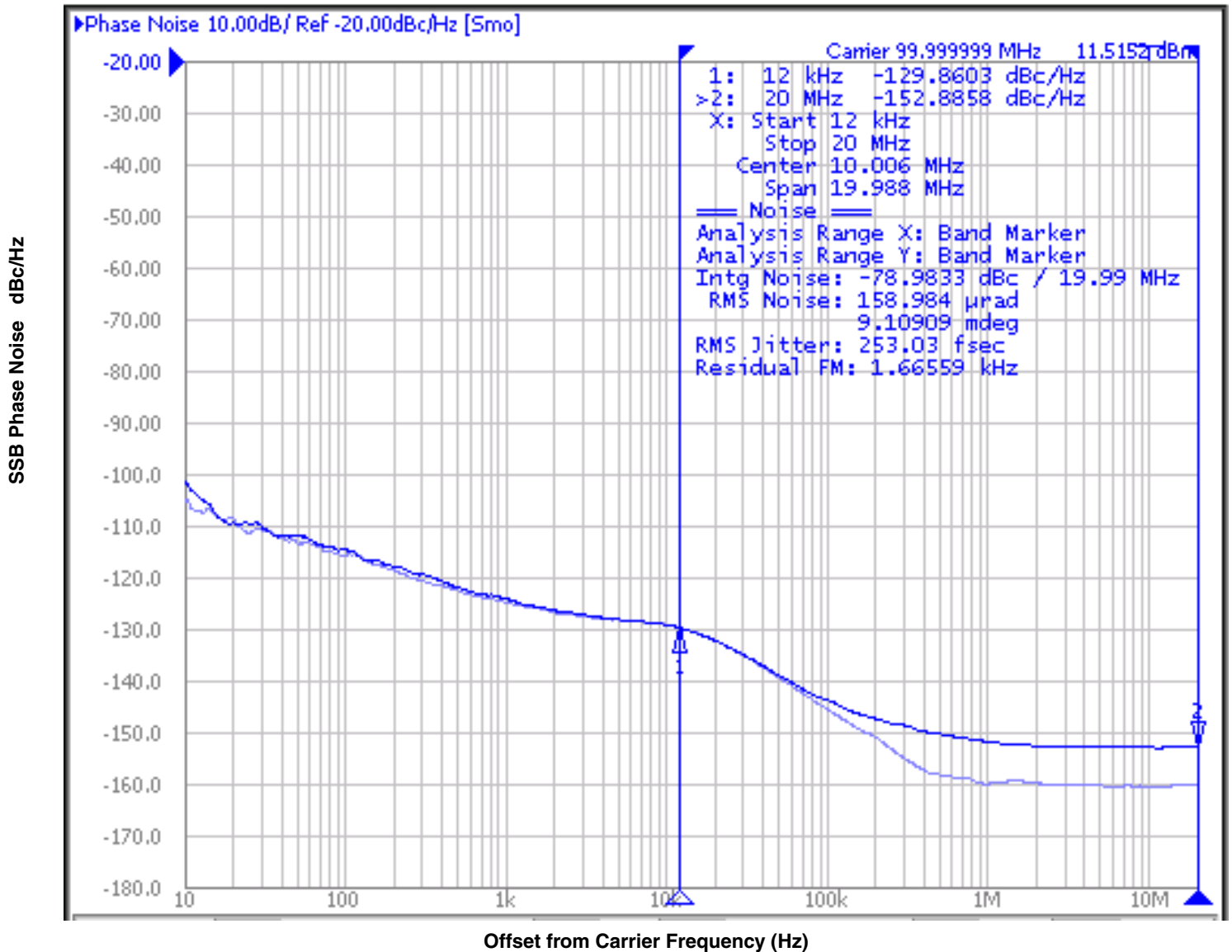

As with most timing specifications, phase noise measurements has issues relating to the limitations of the equipment. Often the noise floor of the equipment is higher than the noise floor of the device. This is illustrated above. The device meets the noise floor of what is shown, but can actually be lower. The phase noise is dependent on the input source and measurement equipment.

The source generator used is, "Agilent E5052A Signal Source Analyzer".

Parameter Measurement Information

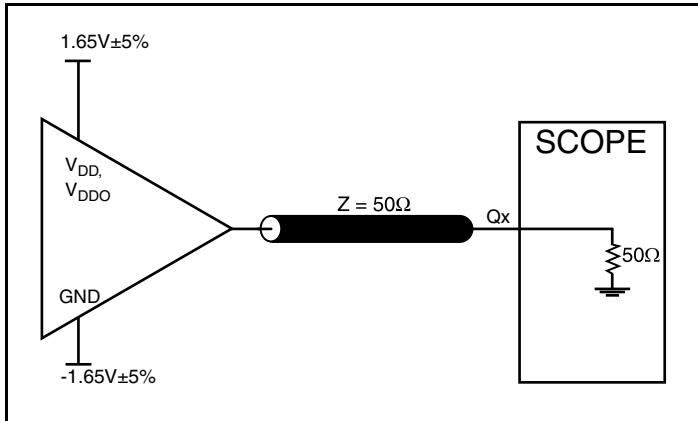

3.3V Output Load AC Test Circuit

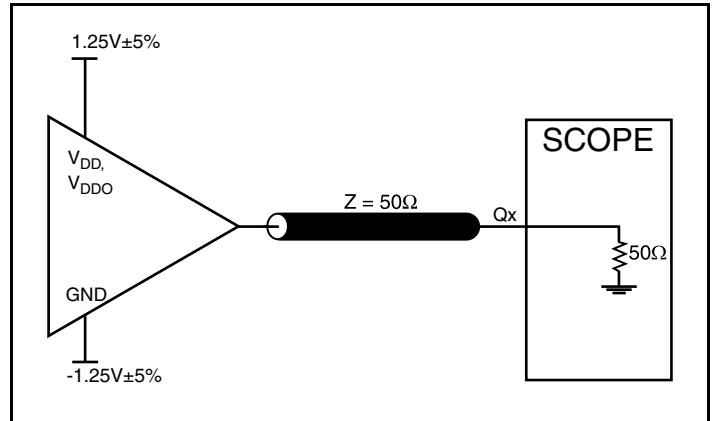

2.5V Output Load AC Test Circuit

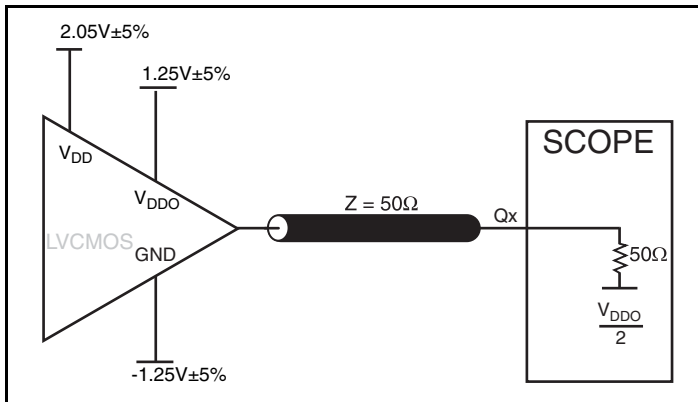

3.3V Core/2.5V Output Load AC Test Circuit

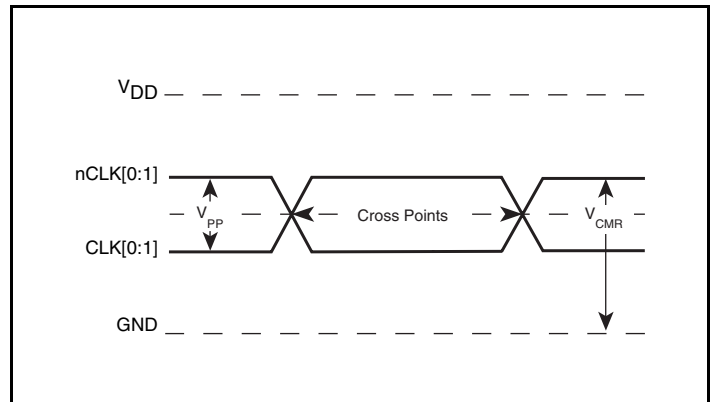

Differential Input Level

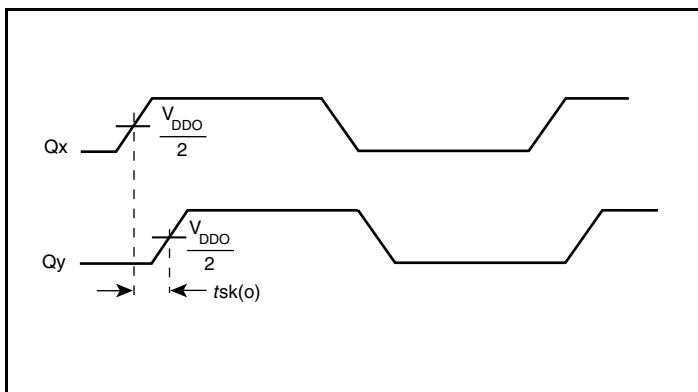

Output Skew

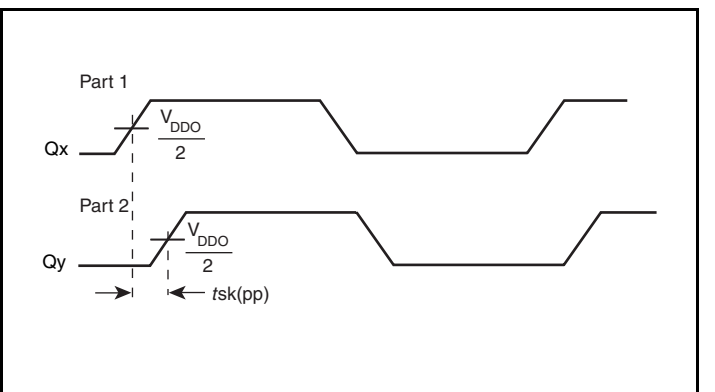

Part-to-Part Skew

Parameter Measurement Information, continued

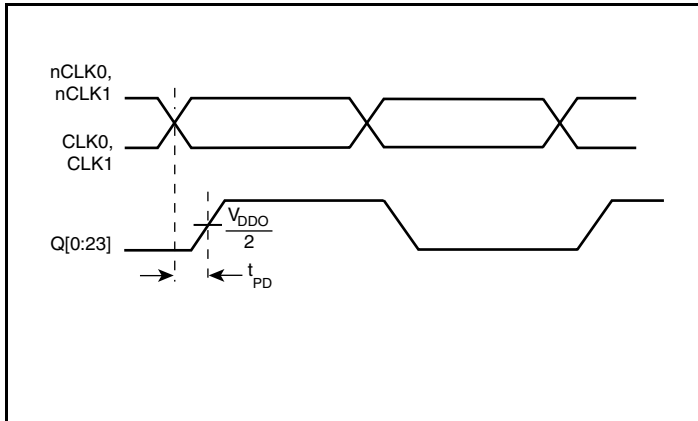

Propagation Delay

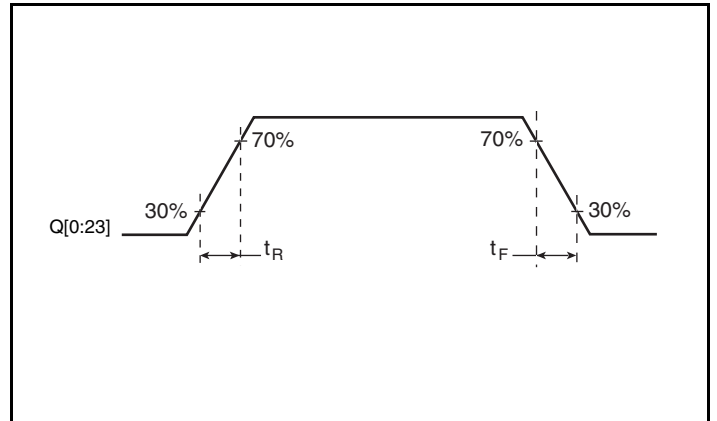

Output Rise/Fall Time

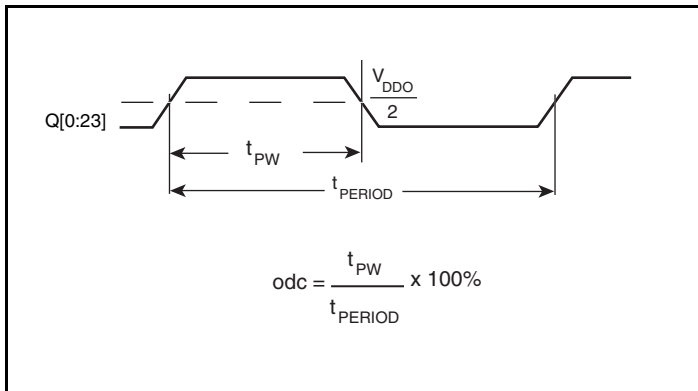

Output Duty Cycle/Pulse Width/Period

Application Information

Recommendations for Unused Input and Output Pins

Inputs:

CLK/nCLK Inputs

For applications not requiring the use of the differential input, both CLKx and nCLKx can be left floating. Though not required, but for additional protection, a 1kΩ resistor can be tied from CLKx to ground.

LVCN07 Control Pins

All control pins have internal pullups or pulldowns; additional resistance is not required but can be added for additional protection. A 1kΩ resistor can be used.

Outputs:

LVCN07 Outputs

All unused LVCN07 outputs can be left floating. There should be no trace attached.

Wiring the Differential Input to Accept Single-Ended Levels

Figure 1 shows how a differential input can be wired to accept single ended levels. The reference voltage $V_{REF} = V_{DD}/2$ is generated by the bias resistors R1 and R2. The bypass capacitor (C1) is used to help filter noise on the DC bias. This bias circuit should be located as close to the input pin as possible. The ratio of R1 and R2 might need to be adjusted to position the V_{REF} in the center of the input voltage swing. For example, if the input clock swing is 2.5V and $V_{DD} = 3.3V$, R1 and R2 value should be adjusted to set V_{REF} at 1.25V. The values below are for when both the single ended swing and V_{DD} are at the same voltage. This configuration requires that the sum of the output impedance of the driver (R_o) and the series resistance (R_s) equals the transmission line impedance. In addition, matched termination at the input will attenuate the signal in half. This can be done in one of two ways. First, R3 and R4 in parallel should equal the transmission

line impedance. For most 50Ω applications, R3 and R4 can be 100Ω. The values of the resistors can be increased to reduce the loading for slower and weaker LVCN07 driver. When using single-ended signaling, the noise rejection benefits of differential signaling are reduced. Even though the differential input can handle full rail LVCN07 signaling, it is recommended that the amplitude be reduced. The datasheet specifies a lower differential amplitude, however this only applies to differential signals. For single-ended applications, the swing can be larger, however V_{IL} cannot be less than -0.3V and V_{IH} cannot be more than $V_{DD} + 0.3V$. Though some of the recommended components might not be used, the pads should be placed in the layout. They can be utilized for debugging purposes. The datasheet specifications are characterized and guaranteed by using a differential signal.

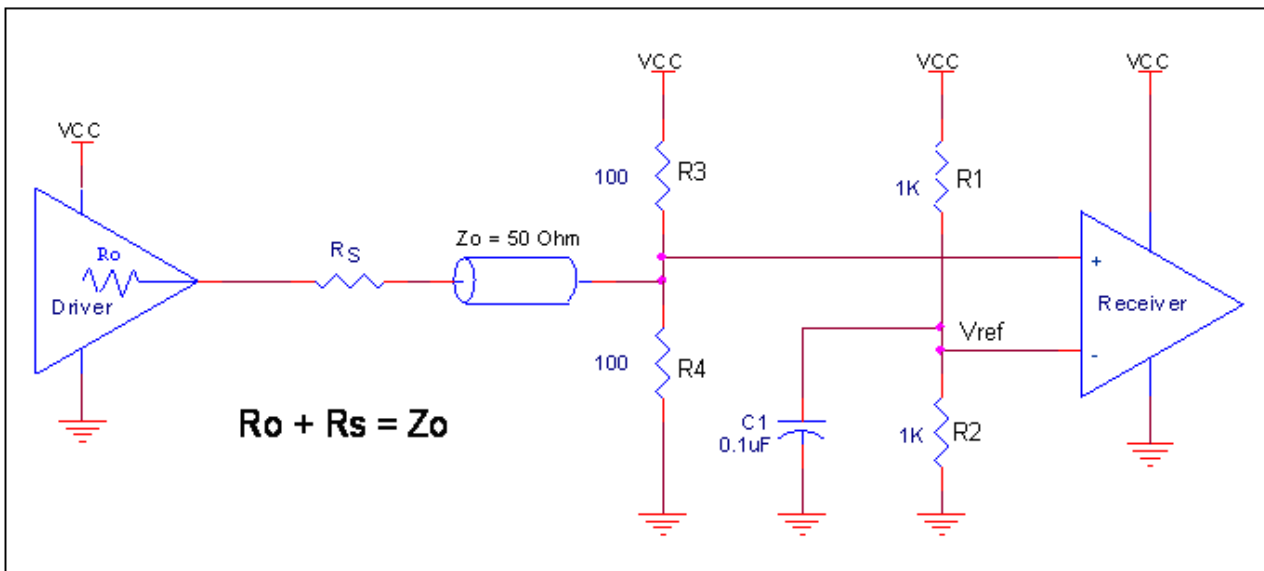

Figure 1. Recommended Schematic for Wiring a Differential Input to Accept Single-ended Levels

Differential Clock Input Interface

The CLKx /nCLKx accepts LVDS, LVPECL, LVHSTL, HCSL and other differential signals. Both signals must meet the V_{PP} and V_{CMR} input requirements. *Figures 2A to 2E* show interface examples for the CLKx/nCLKx input driven by the most common driver types. The input interfaces suggested here are examples only. Please consult

with the vendor of the driver component to confirm the driver termination requirements. For example, in Figure 2A, the input termination applies for IDT open emitter LVHSTL drivers. If you are using an LVHSTL driver from another vendor, use their termination recommendation.

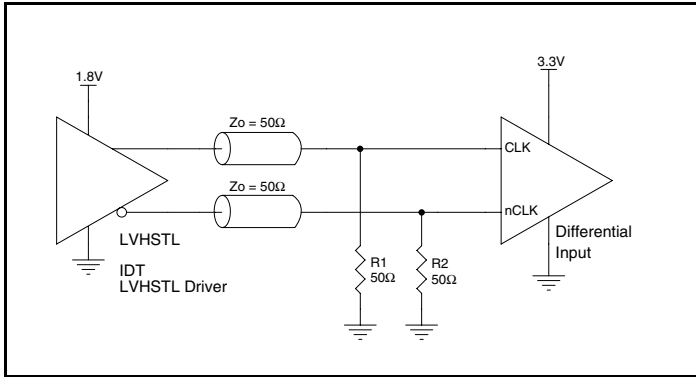

Figure 2A. CLK/nCLK Input Driven by an IDT Open Emitter LVHSTL Driver

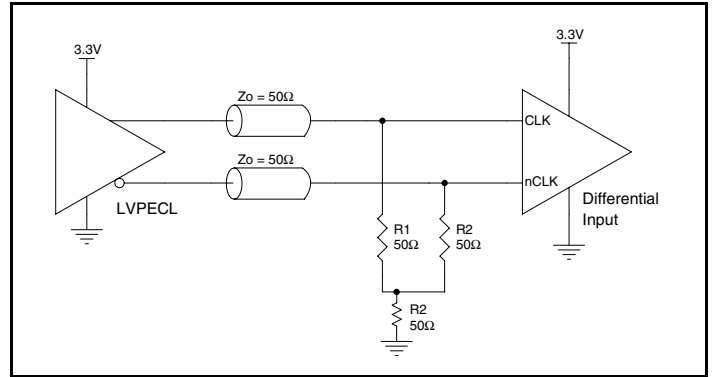

Figure 2B. CLK/nCLK Input Driven by a 3.3V LVPECL Driver

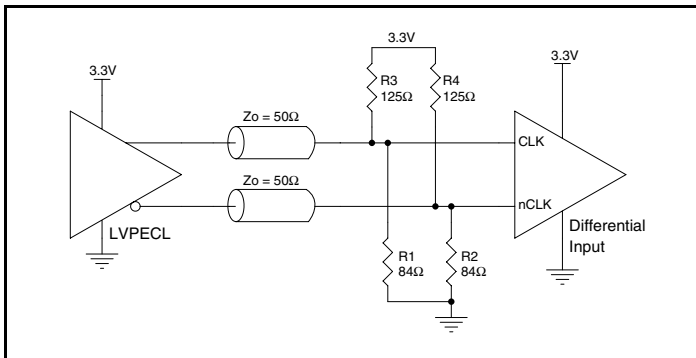

Figure 2C. CLK/nCLK Input Driven by a 3.3V LVPECL Driver

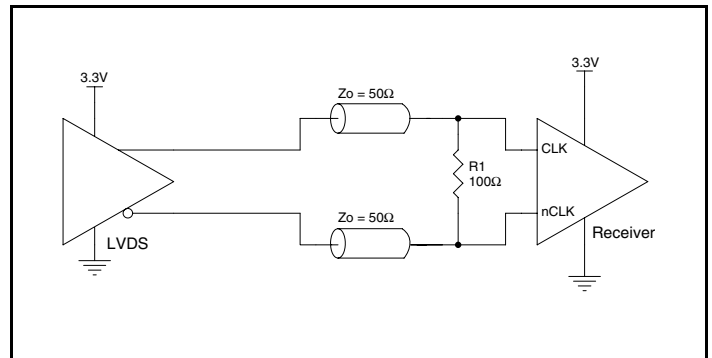

Figure 2D. CLK/nCLK Input Driven by a 3.3V LVDS Driver

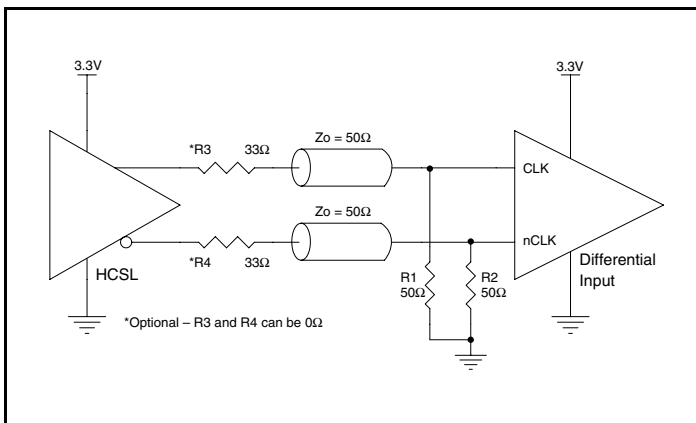

Figure 2E. CLK/nCLK Input Driven by a 3.3V HCSL Driver

Power Considerations

This section provides information on power dissipation and junction temperature for the ICS8344I-01. Equations and example calculations are also provided.

1. Power Dissipation.

The total power dissipation for the ICS8344I-01 is the sum of the core power plus the analog power plus the power dissipated in the load(s). The following is the power dissipation for $V_{DD} = 3.3V + 5\% = 3.465V$, which gives worst case results.

- Power (core)_{MAX} = $V_{DD_MAX} * I_{DD} = 3.465V * 95mA = \mathbf{329.2mW}$
- Output Impedance R_{OUT} Power Dissipation due to Loading 50Ω to $V_{DD}/2$
Output Current $I_{OUT} = V_{DD_MAX} / [2 * (50\Omega + R_{OUT})] = 3.465V / [2 * (50\Omega + 7\Omega)] = \mathbf{30.4mA}$
- Power Dissipation on the R_{OUT} per LVCMOS output
Power (R_{OUT}) = $R_{OUT} * (I_{OUT})^2 = 7\Omega * (30.4mA)^2 = \mathbf{6.47mW}$ per output
- Total Power (R_{OUT}) = $6.47mW * 24 = \mathbf{155mW}$

Dynamic Power Dissipation at 100MHz

$$\text{Power (100MHz)} = C_{PD} * \text{Frequency} * (V_{DD})^2 = 16pF * 100MHz * (3.465V)^2 = \mathbf{19.2mW}$$
 per output

$$\text{Total Power (100MHz)} = 19.2mW * 24 = \mathbf{461mW}$$

Total Power Dissipation

- **Total Power**
= Power (core)_{MAX} + Power (R_{OUT}) + Power (100MHz)
= $329.2mW + 155mW + 461mW$
= **945.2mW**

2. Junction Temperature.

Junction temperature, T_j , is the temperature at the junction of the bond wire and bond pad directly affects the reliability of the device. The maximum recommended junction temperature is 125°C . Limiting the internal transistor junction temperature, T_j , to 125°C ensures that the bond wire and bond pad temperature remains below 125°C .

$$\text{The equation for } T_j \text{ is as follows: } T_j = \theta_{JA} * Pd_total + T_A$$

T_j = Junction Temperature

θ_{JA} = Junction-to-Ambient Thermal Resistance

Pd_total = Total Device Power Dissipation (example calculation is in section 1 above)

T_A = Ambient Temperature

In order to calculate junction temperature, the appropriate junction-to-ambient thermal resistance θ_{JA} must be used. Assuming no air flow and a multi-layer board, the appropriate value is 81.2°C/W per Table 6 below.

Therefore, T_j for an ambient temperature of 70°C with all outputs switching is:

$$70^\circ\text{C} + 0.945W * 81.2^\circ\text{C/W} = 120.9^\circ\text{C}. \text{ This is below the limit of } 125^\circ\text{C}.$$

This calculation is only an example. T_j will obviously vary depending on the number of loaded outputs, supply voltage, air flow and the type of board (multi-layer).

Table 6. Thermal Resistance θ_{JA} for 48 Lead LQFP, Forced Convection

θ_{JA} by Velocity			
Meters per Second	0	1	2.5
Multi-Layer PCB, JEDEC Standard Test Boards	53.9°C/W	47.7°C/W	45.0°C/W

Reliability Information

Table 7. θ_{JA} vs. Air Flow Table for a 48 Lead LQFP

θ_{JA} vs. Air Flow			
Meters per Second	0	1	2.5
Multi-Layer PCB, JEDEC Standard Test Boards	53.9°C/W	47.7°C/W	45.0°C/W

Transistor Count

The transistor count for ICS8344I-01 is: 1503

Package Outline and Package Dimensions

Package Outline - Y Suffix for 48 Lead LQFP

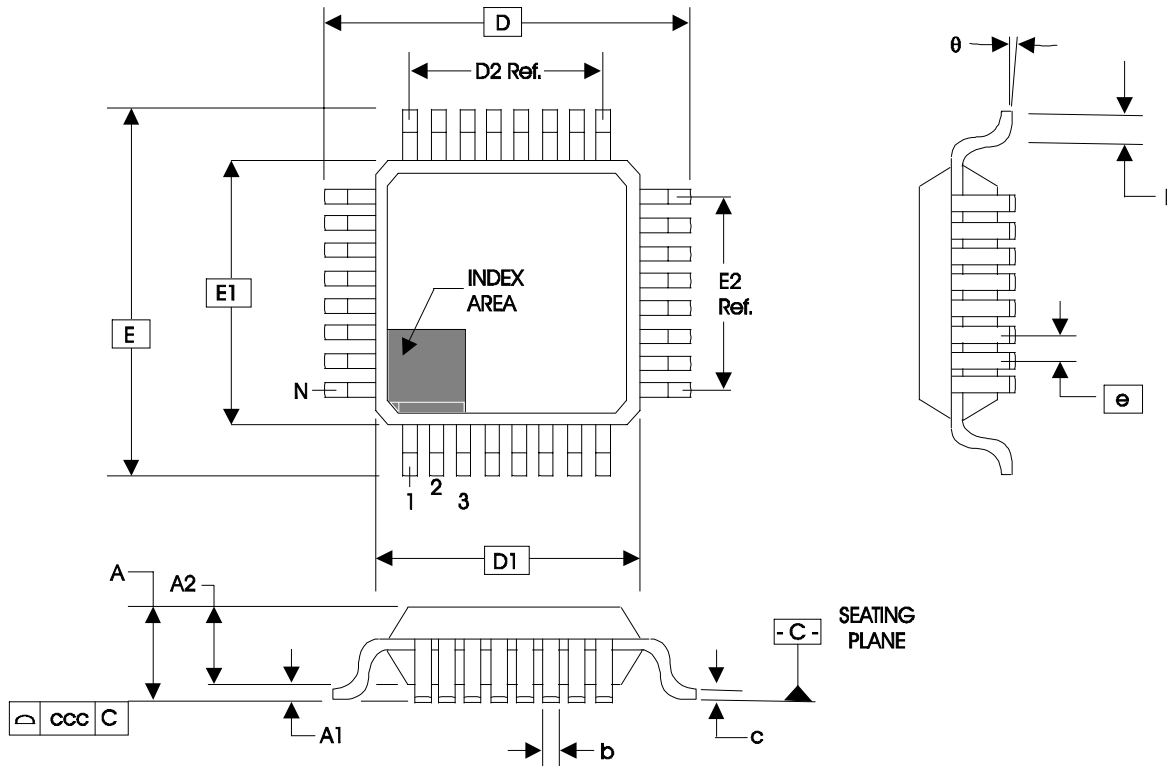

Table 7. Package Dimensions for 48 Lead LQFP

JEDEC Variation: ABC - HD			
All Dimensions in Millimeters			
Symbol	Minimum	Nominal	Maximum
N	48		
A			1.60
A1	0.05	0.10	0.15
A2	1.35	1.4	1.45
b	0.17	0.22	0.27
c	0.09	0.15	0.20
D & E	9.00 Basic		
D1 & E1	7.00 Basic		
D2 & E2	5.50 Ref.		
e	0.50 Basic		
L	0.45	0.60	0.75
θ	0°		7°
ccc			0.08

Reference Document: JEDEC Publication 95, MS-026

Ordering Information

Table 8. Ordering Information

Part/Order Number	Marking	Package	Shipping Packaging	Temperature
8344AYI-01LF	ICS8344AI01L	"Lead-Free" 48 Lead LQFP	Tray	-40°C to 70°C
8344AYI-01ILFT	ICS8344AI01L	"Lead-Free" 48 Lead LQFP	1000 Tape & Reel	-40°C to 70°C

NOTE: Parts that are ordered with an "LF" suffix to the part number are the Pb-Free configuration and are RoHS compliant.

IMPORTANT NOTICE AND DISCLAIMER

RENESAS ELECTRONICS CORPORATION AND ITS SUBSIDIARIES (“RENESAS”) PROVIDES TECHNICAL SPECIFICATIONS AND RELIABILITY DATA (INCLUDING DATASHEETS), DESIGN RESOURCES (INCLUDING REFERENCE DESIGNS), APPLICATION OR OTHER DESIGN ADVICE, WEB TOOLS, SAFETY INFORMATION, AND OTHER RESOURCES “AS IS” AND WITH ALL FAULTS, AND DISCLAIMS ALL WARRANTIES, EXPRESS OR IMPLIED, INCLUDING, WITHOUT LIMITATION, ANY IMPLIED WARRANTIES OF MERCHANTABILITY, FITNESS FOR A PARTICULAR PURPOSE, OR NON-INFRINGEMENT OF THIRD-PARTY INTELLECTUAL PROPERTY RIGHTS.

These resources are intended for developers who are designing with Renesas products. You are solely responsible for (1) selecting the appropriate products for your application, (2) designing, validating, and testing your application, and (3) ensuring your application meets applicable standards, and any other safety, security, or other requirements. These resources are subject to change without notice. Renesas grants you permission to use these resources only to develop an application that uses Renesas products. Other reproduction or use of these resources is strictly prohibited. No license is granted to any other Renesas intellectual property or to any third-party intellectual property. Renesas disclaims responsibility for, and you will fully indemnify Renesas and its representatives against, any claims, damages, costs, losses, or liabilities arising from your use of these resources. Renesas' products are provided only subject to Renesas' Terms and Conditions of Sale or other applicable terms agreed to in writing. No use of any Renesas resources expands or otherwise alters any applicable warranties or warranty disclaimers for these products.

(Disclaimer Rev.1.01 Jan 2024)

Corporate Headquarters

TOYOSU FORESIA, 3-2-24 Toyosu,
Koto-ku, Tokyo 135-0061, Japan
www.renesas.com

Trademarks



Renesas and the Renesas logo are trademarks of Renesas Electronics Corporation. All trademarks and registered trademarks are the property of their respective owners.

Contact Information

For further information on a product, technology, the most up-to-date version of a document, or your nearest sales office, please visit www.renesas.com/contact-us/.

Looking for pricing, stock, or lifecycle information?

Click below to explore more details on WIN SOURCE:

-  [View 8344AYI-01LF on WIN SOURCE](#)
-  [Renesas Electronics America](#) Information

Optimize Your Supply Chain with WIN SOURCE Solutions

-  Global Sourcing Solution
-  Obsolete Management
-  Cost Control Management
-  Shortage Management
-  Alternative Solution
-  Excess Inventory Management