



**THE DATASHEET OF**  
**75107**





# APM HEXSEAL

## Sealing Specialists



APM HEXSEAL was founded in 1947 with the mission to develop and manufacture environmental sealing solutions to protect and prolong the life of electromechanical switches and circuit breakers in hostile environmental conditions around the globe. This focused effort resulted in the development of an extensive line of standard silicone sealing boots that are compatible with the vast majority of switches, breakers, encoders, potentiometers and rotary devices used throughout the world today.



Complimentary sealing products were soon developed and patented, including a complete line of reusable, self-sealing fasteners, and silicone colorizing incandescent lamp filters that transmit colors for instrument panels and lighted pushbutton switches.



Drawing upon our experience with precision transfer and compression molding using a wide range of elastomers, rubber-to-metal bonding and coating treatments, APM Hexseal's Custom Design Department offers an efficient method to develop your custom sealing needs,

### Sealing Boots & Bushings

- ◆ Switch and Potentiometer Boots
- ◆ Circuit Breaker Boots
- ◆ Specialty Bushing Seals
- ◆ Custom Elastomeric Sealing Solutions

### Self-Sealing Hardware

- ◆ SEELSKREW® Self-Sealing Screws
- ◆ SEELBOLT® Self-Sealing Bolts
- ◆ SEELNUT® Molded Self-Sealing Nuts
- ◆ SEELOC® Molded Sealing Washers



from concept all the way to production.



**“APM Hexseal has a solution looking for your problem.”**



ISO 9001:2015 Registered



(800) 498-9034  
www.apmhexseal.com

# APM Hexseal Boots for Toggle, Pushbutton & Rotary Switches

Any unsealed electrical devices mounted to a control panel or piece of electrical equipment can fall victim to the impacts of hostile environmental factors if not properly protected. In this context, "environmental" is a very broad term, encompassing any number of possible factors, including weather conditions like rain, snow or prolonged wind and sun exposure, pressure changes from submersion in fluids or changes in altitude, contaminants such as water, ice, salt, air, dust, dirt, grease, chemicals, and even spilled beverages.

APM Hexseal's Sealing Boots are designed to protect the vulnerable areas of a device, and create a seal against the mounting panel, providing strong protection for the device itself, and for the overall function of the system.

### MATERIAL SPECIFICATIONS

For APM Hexseal® Standard Threaded Toggle, Pushbutton & Rotary Boots

- Elastomer:** Silicone † conforms to A-A-59588, Class 3A, GR50, Gray ‡
- Mounting Nut:** Brass, Nickel Plated
- Temperature Range:** -103° F to +400° F ( -75° C to +204° C)
- Resistant to:** Splash, salt spray, sunlight, ozone, weather, fungus, dust, and most acids and lubricating oils.
- Shelf Life:** Excess of 25 years.
- Enclosure Protection:** IEC IP66 / IP68 •

† Alternative elastomers options are available by request. (See table on page 7 for options.)  
 ‡ Additional durometer and color options available. Please contact us for details.  
 • A dual IP code rating indicates that both ratings apply.

APM Hexseal's UL and ULC Recognized Components conform to UL Standard 50. Contact us for a complete list of our Recognized Components and ratings.

Ensure the safety, reliability and function of your critical systems...

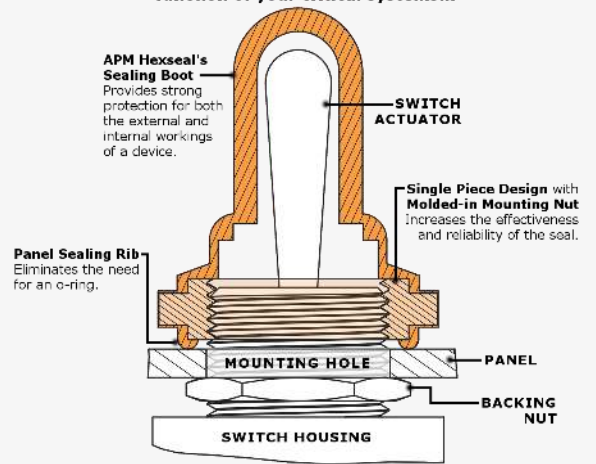

See Figure 1

### Full Toggle Boots with Secondary Inner Seal

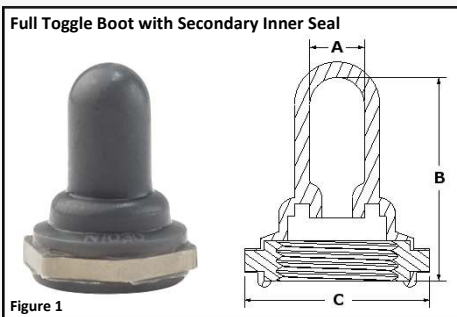

Figure 1

APM Hexseal Part #	Military Part #	Thread Size	Maximum Bat Height (Above Bushing)	DIMENSIONS						System of Measurement
				Internal Diameter (A)		Height (B)		Hex Size/Outer Diameter (C)		
				in	mm	in	mm	in	mm	
C1131/27	-	15/32-32 UNS-2B	0.710"	0.219	5.56	0.937	23.80	0.625	15.88	Imperial
N1030	M5423/01-01	15/32-32 UNS-2B	0.660"	0.219	5.56	0.844	21.44	0.625	15.88	Imperial
N5030	M5423/04-01	1/4-40 UNS-2B	0.310"	0.104	2.64	0.422	10.72	0.375	9.53	Imperial

### Full Toggle Boots with Constant Internal Diameter

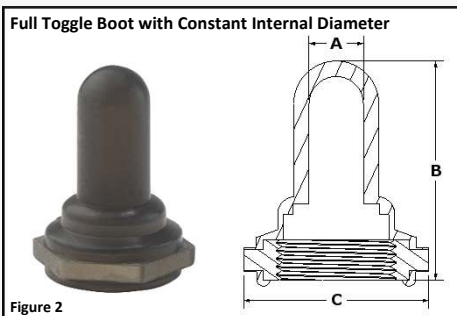

Figure 2

APM Hexseal Part #	Military Part #	Thread Size	Maximum Bat Height (Above Bushing)	DIMENSIONS						System of Measurement
				Internal Diameter (A)		Height (B)		Hex Size/Outer Diameter (C)		
				in	mm	in	mm	in	mm	
1131/26	-	15/32-32 UNS-2B	0.900"	0.212	5.38	1.093	27.76	0.625	15.88	Imperial
50154	-	15/32-32 UNS-2B	0.925"	0.300	7.62	1.110	28.19	0.625	15.88	Imperial
C1131/28	-	15/32-32 UNS-2B	0.710"	0.219	5.56	0.937	23.80	0.625	15.88	Imperial
IN1030	-	15/32-32 UNS-2B	0.660"	0.219	5.56	0.844	21.44	0.625	15.88	Imperial
IQ1030 ▲	-	15/32-32 UNS-2B	0.735"	0.250	6.35	0.975	24.77	0.875	22.22	Imperial
N5030L	M5423/05-01	1/4-40 UNS-2B	0.370"	0.062	1.57	0.500	12.70	0.375	9.53	Imperial
N5030S	-	1/4-40 UNS-2B	0.500"	0.062	1.57	0.594	15.08	0.375	9.53	Imperial
1131/26 M12x.75	-	M12 x 0.75 6H	22.86mm	0.225	5.72	1.093	27.76	0.625	15.88	Metric
1131/26 M12x1	-	M12 x 1 6H	22.86mm	0.225	5.72	1.093	27.76	0.625	15.88	Metric
1131/31 M12	-	M12 x 1 6H	16.97mm	0.256	6.50	0.844	21.44	0.625	15.88	Metric
1131/40	-	M12 x 1 6H	16.97mm	0.234	5.95	0.859	21.83	0.625	15.88	Metric
C1131/41	-	M12 x 0.75 6H	16.08mm	0.210	5.30	0.850	21.60	0.625	15.88	Metric
IN1030 RFI ♦	M5423/01-02	15/32-32 UNS-2B	0.660"	0.219	5.56	0.844	21.44	0.625	15.88	Imperial

▲ IQ Toggle Boots "Install Quickly" over pre-installed switches (not shown). Insert is aluminum with a brass washer. Contact us for images and information.  
 ♦ Toggle Boot with EMI/RFI Shielding (not shown). Contact us for images and information.

See Figure 2

### Half & Open Toggle Boots with Exposed Actuator

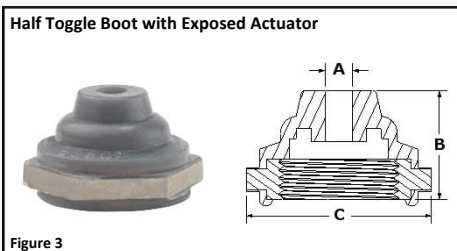

Figure 3

APM Hexseal Part #	Military Part #	Thread Size	DIMENSIONS						Toggle Bat Diameter (Min. - Max.)	System of Measurement	
			Throat Diameter (A)		Height (B)		Flat/Hex Size (C)				
			in	mm	in	mm	in	mm			
1132/60 ★	-	15/32-32 UNS-2B	0.160	4.06	0.310	7.87	0.625	15.88	0.170-0.200	4.32-5.08	Imperial
C1132/20	-	15/32-32 UNS-2B	0.109	2.77	0.437	11.10	0.625	15.88	0.115-0.240	2.92-6.10	Imperial
C1132/26 ◊	-	15/32-32 UNS-2B	0.210	5.33	0.848	21.54	0.625	15.88	0.270-0.285	6.86-7.24	Imperial
N1030B	M5423-02-01	15/32-32 UNS-2B	0.109	2.77	0.437	11.10	0.625	15.88	0.115-0.240	2.92-6.10	Imperial
N5032B	M5423/11-01	1/4-40 UNS-2B	0.047	1.19	0.250	6.35	0.375	9.53	0.062-0.188	1.57-4.78	Imperial
1132/17 M5x0.5	-	M5 x 0.5 6H	0.043	1.10	0.225	5.70	0.315	8.00	0.062-0.188	1.57-4.78	Metric
1132/33 M12x1	-	M12 x 1 6H	0.093	2.36	0.437	11.10	0.625	15.88	0.115-0.240	2.92-6.10	Metric
1132/60 M12 ★	-	M12 x 1 6H	0.160	4.06	0.310	7.87	0.625	15.88	0.170-0.200	4.32-5.08	Metric

★ "Ultra Flex" Half-Toggle Boot with patented inverted bellows design for use with sensitive switches (not shown). Contact us for images and information.  
 ◊ Open Toggle Boot for lever lock switches (not shown). Contact us for images and information.

See Figure 3

This catalog is a **partial** representation of APM Hexseal's many product lines. Please contact us directly for additional product options, as well as to request a Quote or place an Order.



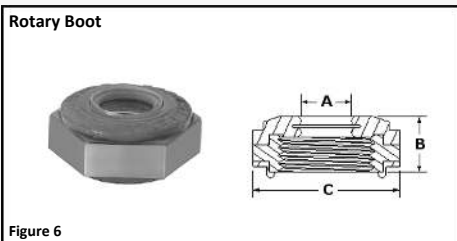
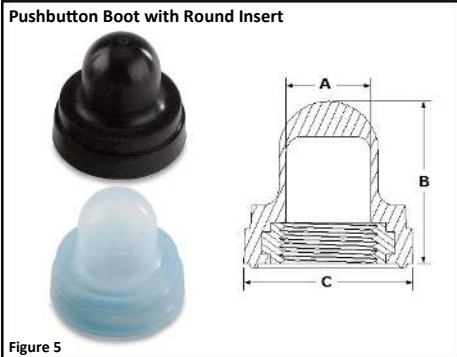
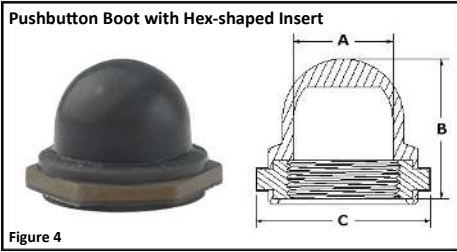

**Pushbutton Boots with Hex-shaped Insert**

See Figure 4

APM Hexseal Part #	Military Part #	Thread Size	Maximum Plunger Height (Above Bushing)		DIMENSIONS						System of Measurement
					Internal Diameter (A)		Height (B)		Hex Size/Outer Diameter (C)		
			in	mm	in	mm	in	mm	in	mm	
1231/8	-	3/8-27 UNS-2B	0.397	10.08	0.300	7.62	0.653	16.59	0.500	12.70	Imperial
1231/35	-	3/8-32 UNEF-2B	0.418	10.62	0.300	7.62	0.670	17.20	0.500	12.70	Imperial
1231/51	-	3/8-27 UNS-2B	0.665	16.88	0.313	7.95	0.875	22.23	0.500	12.70	Imperial
1238/1 SS ▲	-	15/32-32 UNS-2B	0.306	7.77	0.422	10.72	1.008	25.60	0.750	19.05	Imperial
N3030	M5423/07-01	15/32-32 UNS-2B	0.281	7.14	0.422	10.72	0.547	13.89	0.625	15.88	Imperial
N3030 RFI ★	M5423/07-06	15/32-32 UNS-2B	0.281	7.14	0.422	10.72	0.547	13.89	0.625	15.88	Imperial
N3040	M5423/07-04	5/8-24 UNEF-2B	0.281	7.14	0.515	13.08	0.609	15.47	0.750	19.05	Imperial
N5040	M5423/10-03	1/4-40 UNS-2B	0.141	3.58	0.188	4.78	0.313	7.95	0.375	9.53	Imperial
N5040G	M5423/10-01	1/4-32 UNEF-2B	0.203	5.16	0.188	4.78	0.313	7.95	0.375	9.53	Imperial
N5040R	M5423/10-02	1/4-40 UNS-2B	0.203	5.16	0.188	4.78	0.313	7.95	0.375	9.53	Imperial
N5045	-	8-40 UNS-2B	0.188	4.78	0.120	3.05	0.297	7.54	0.250	6.35	Imperial
NC3030	M5423/07-02	15/32-32 UNS-2B	0.438	11.13	0.422	10.72	0.719	18.26	0.625	15.88	Imperial
NC3030 7/16-28	-	7/16-28 UNEF-2B	0.438	11.13	0.422	10.72	0.719	18.26	0.625	15.88	Imperial
NH3030	M5423/07-03	1/2-32 UN-2B	0.281	7.14	0.422	10.72	0.547	13.89	0.625	15.88	Imperial
NC3030FL ♦	-	15/32-32 UNS-2B	0.520	13.21	0.344	8.74	0.797	20.24	0.625	15.88	Imperial
NC3030H M12x1	-	M12 x 1 6H	0.469	11.90	0.422	10.72	0.734	18.64	0.625	15.88	Metric

▲ Armored Pushbutton Boot (not shown). Contact us for images and information.  
 ★ Pushbutton Boot with EMI/RFI Shielding (not shown). Contact us for images and information.  
 ♦ Flat Top Pushbutton Boot (not shown). Contact us for images and information.

**Pushbutton Boots with Round Insert (Aluminum)**

See Figure 5

APM Hexseal Part #	Military Part #	Thread Size	Maximum Plunger Height (Above Bushing)		DIMENSIONS						System of Measurement
					Internal Diameter (A)		Height (B)		Hex Size/Outer Diameter (C)		
			in	mm	in	mm	in	mm	in	mm	
C1221/22	-	3/8-24 UNF-2B	0.330	8.40	0.320	8.13	0.609	15.47	0.640	16.26	Imperial
C1221/24 ◊	-	3/8-27 UNS-2B	0.419	10.64	0.300	7.62	0.609	15.47	0.640	16.26	Imperial
C1221/25	-	3/8-27 UNS-2B	0.419	10.64	0.300	7.62	0.609	15.47	0.640	16.26	Imperial
C1221/21 M10	-	M10 x 1 6H	0.330	8.40	0.320	8.13	0.609	15.47	0.640	16.26	Metric
C1221/27	-	M11 x 1 6H	0.267	6.78	0.320	8.13	0.609	15.47	0.720	18.29	Metric

◊ Boot is made from APM Hexseal's clear RUBRGLAS®.

**Rotary Boots**

See Figure 6

APM Hexseal Part #	Military Part #	Thread Size	DIMENSIONS								System of Measurement
			Shaft Size (A)		Height (B)		Hex Size (C)				
			in	mm	in	mm	in	mm			
N9030x1/4	M5423/09-02	3/8-32 UNEF-2B	0.250	6.35	0.219	5.56	0.500	12.70	Imperial		
N9040x1/8	M5423/09-03	1/4-32 UNEF-2B	0.125	3.18	0.219	5.56	0.375	9.53	Imperial		
N9042x1/8	-	1/4-28 UNF-2B	0.125	3.18	0.219	5.56	0.375	9.53	Imperial		
N9060x1/4	M5423/09-04	15/32-32 UNS-2B	0.250	6.35	0.219	5.56	0.625	15.88	Imperial		
1332/39	-	M7x.75 6H	0.196	5.00	0.200	5.50	0.500	12.70	Metric		
1332/45	-	M10x1 6H	0.236	6.00	0.236	5.90	0.500	12.70	Metric		
1332/46	-	M10x.75 6H	0.236	6.00	0.236	5.90	0.500	12.70	Metric		
C1332/41	-	M9x.75 6H	0.250	6.35	0.219	5.56	0.500	12.70	Metric		

**APM Hexseal Bushing Seals For Switch Panel Cut-Outs**

Bushing Seals pack all the sealing power of a boot, but focus on the mounting hole as opposed to the switch itself. Installed before a switch locking nut, the bushing seal fits snugly against the mounting panel, sealing the mounting hole from any possible intrusion. Bushing Seals are small, inconspicuous and perfect for already sealed toggle, push button and rotary switches.

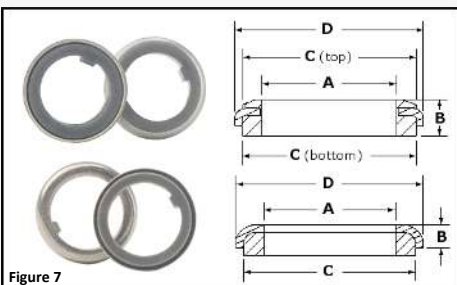

**Bushing Seals**

See Figure 7

APM Hexseal Part #	Military Part #	DIMENSIONS								Seal Style
		Bushing Size (A)		Height (B)		Seal Diameter (C)		Outer Diameter (D)		
		in	mm	in	mm	in	mm	in	mm	
60064	M5423/17-01	0.469	11.91	0.120	3.03	Top: 0.610 Bottom: 0.610	Top: 15.49 Bottom: 15.49	0.662	16.81	Double-Side Seal
60065	-	0.375	9.53	0.120	3.03	Top: 0.500 Bottom: 0.522	Top: 12.70 Bottom: 13.26	0.572	14.53	Double-Side Seal
60225	M5423/16-01	0.469	11.91	0.120	3.03	0.610	15.49	0.662	16.81	Single-Side Seal

**MATERIAL SPECIFICATIONS**  
 For APM Hexseal® Standard Bushing Seals

**Elastomer:** Silicone conforms to A-A-59588, Class 3A, GR50 †, Gray ‡  
**Mounting Nut:** 18/8 Stainless Steel  
**Temperature Range:** -103° F to +400° F (-75° C to +204° C)  
**Resistant to:** Splash, salt spray, sunlight, ozone, weather, fungus, dust, and most acids and lubricating oils.  
**Shelf Life:** Excess of 25 years.  
**Enclosure Protection:** IEC IP66 / IP68 •

† Durometer options available. Please contact us for details.  
 ‡ Additional colors available. Please contact us for details.  
 • A dual IP code rating indicates that both ratings apply.

APM Hexseal's UL and ULC Recognized Components conform to UL Standard 50.  
 Contact us for a complete list of our Recognized Components and ratings.



This catalog is a **partial** representation of APM Hexseal's many product lines. Please contact us directly for additional product options, as well as to request a Quote or place an Order.

# APM Hexseal Boots for Circuit Breakers & Rocker Switches

Circuit breakers perform a very valuable role in all sorts of control systems, protecting equipment from short circuits and electrical overloads. APM Hexseal's lever-actuated circuit breaker boots are designed to protect these critical devices, extending breaker life-spans and in turn helping to ensure long-term security of the system as a whole. Molded from APM Hexseal's transparent silicone RUBRGLAS<sup>®</sup>, which is specially formulated to maintain clarity and prevent yellowing over time, these boots allow for easy device operation and status recognition while maintaining APM Hexseal's exceptional environmental protection from weather exposure, wash downs, salt water, lubricants, solvents, dust, dirt, grease and any number of other environmental elements that could potentially threaten electrical components. Our two distinct boot styles are Back-of-Panel, secured behind the breaker mounting panel, and Front-of-Panel, mounted to the outside of a panel using a sturdy metal frame. Both styles are secured using APM Hexseal's self-sealing Seelskrews.

Much like our Circuit Breaker Boots, APM Hexseal's Rocker Boots are often molded from transparent silicone RUBRGLAS<sup>®</sup> which makes for easy viewing of the switch position. The majority of our Rocker Boots do not include an insert or frame, and are designed to install on the switch prior to the switch installation.



### MATERIAL SPECIFICATIONS

For APM Hexseal<sup>®</sup> Standard Rocker and Lever-Actuated Circuit Breaker Boots

**Elastomer:** APM HEXSEAL RUBRGLAS<sup>®</sup> (transparent Silicone) conforms to A-A-59588, Class 3A, GR50 †

**Frame (Front-of-Panel Mounted Only):** Low Carbon Steel ‡ with Zinc-Chromate Plating •

**Temperature Range:** -103° F to +400° F ( -75° C to +204° C)

**Resistant to:** Splash, salt spray, sunlight, ozone, weather, fungus, dust, and most acids and lubricating oils.

**Shelf Life:** Excess of 25 years.

**Enclosure Protection:** Rocker Boots— IEC IP55; Front-of-Panel Mounted— IEC IP66 / IP68 ◊; Back-of-Panel Mounted— IEC IP66 / IP68 ◊

† Durometer options available. Please contact us for details.

‡ Frames are also available in Stainless Steel for extremely aggressive environments.

• Contact us for details on our standard 3-step frame finish.

◊ A dual IP code rating indicates that both ratings apply.

APM Hexseal's UL and ULC Recognized Components conform to UL Standard 50. Contact us for a complete list of our Recognized Components and ratings.

### Front-of-Panel Mounting

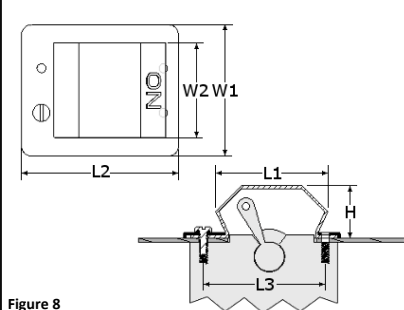

Figure 8

### Circuit Breaker Boots, Front-of-Panel Mounting

See Figure 8

APM Hexseal Part #	Military Part #	Poles	Marks	DIMENSIONS										Standard Seelskrews <sup>®</sup> Included ♦		
				Height (H)		Length 1 (L1)		Length 2 (L2)		Length 3 (L3)		Width 1 (W1)			Width 2 (W2)	
				in	mm	in	mm	in	mm	in	mm	in	mm		in	mm
HE1015	M5423/14-05	1-Pole	ON	0.875	22.22	1.875	47.63	2.625	66.66	2.062	52.37	1.375	34.93	0.875	22.22	S6-32x3/8" 2701 2 Count
HE1020	M5423/14-06	2-Pole	ON	0.875	22.22	1.875	47.63	2.656	67.46	2.062	52.37	2.219	56.36	1.594	40.49	S6-32x3/8" 2701 4 Count
HE1045	-	1-Pole	-	0.450	11.43	1.300	33.02	1.900	48.26	1.660	42.16	0.800	20.32	1.200	30.48	S6-32x3/8" 2701 2 Count
HE1050	M5423/14-07	3-Pole	ON	0.875	22.22	1.875	47.63	2.656	67.46	2.062	52.37	2.969	75.41	2.344	59.54	S6-32x3/8" 2701 6 Count
HE1070	M5423/14-03	3-Pole	ON	0.922	23.42	2.000	50.80	3.719	94.46	2.750	69.85	3.656	92.86	3.156	80.16	S6-32x3/8" 2701 6 Count

♦ Metric Seelskrews are also available by request.

### Back-of-Panel Mounting

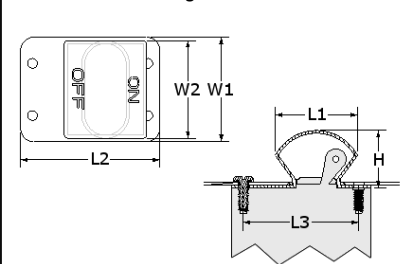

Figure 9

### Circuit Breaker Boots, Back-of-Panel Mounting

See Figure 9

APM Hexseal Part #	Military Part #	Poles	Marks	DIMENSIONS										Standard Seelskrews <sup>®</sup> Included ♦		
				Height (H)		Length 1 (L1)		Length 2 (L2)		Length 3 (L3)		Width 1 (W1)			Width 2 (W2)	
				in	mm	in	mm	in	mm	in	mm	in	mm		in	mm
1113/40	-	1-Pole	ON/OFF	0.813	20.65	1.188	30.18	2.000	50.80	1.660	42.16	0.750	19.50	0.656	16.66	S6-32x5/16" 2701 2 Count
1113/42	-	2-Pole	ON/OFF	0.813	20.65	1.188	30.18	2.000	50.80	1.660	42.16	1.500	38.10	1.406	35.71	S6-32x5/16" 2701 4 Count
1113/43	-	3-Pole	ON/OFF	0.813	20.65	1.188	30.18	2.000	50.80	1.660	42.16	2.250	57.15	2.156	54.76	S6-32x5/16" 2701 6 Count

♦ Metric Seelskrews are also available by request.

### Rocker Boot

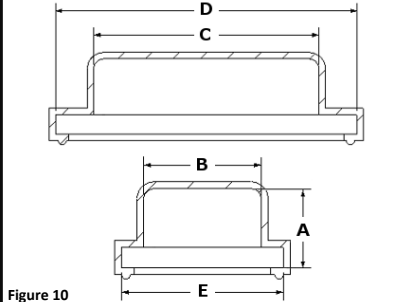

Figure 10

### Rocker Boots

See Figure 10

APM Hexseal Part #	Military Part #	DIMENSIONS										Compatible Switches (Partial List)
		Height (A)		Width 1 (B)		Length 1 (C)		Length 2 (D)		Width 2 (E)		
		in	mm	in	mm	in	mm	in	mm	in	mm	
1113/62	-	0.297	7.54	0.797	20.24	0.687	17.45	1.093	27.76	0.968	24.61	Eaton/Arrow Hart 2600 Series
1113/66	-	0.228	5.79	0.348	8.84	0.531	13.49	0.750	19.05	0.531	13.49	Carling 611/621-Series
1113/70	-	0.297	7.54	0.437	11.10	0.875	22.23	1.218	30.94	0.640	16.27	Carling RSC-Series
1113/71	-	0.413	10.49	0.687	17.45	1.046	26.57	1.327	33.71	0.703	17.86	Carling M Series Sensata/Airpax R11 Eaton/Heinemann LC-1

This catalog is a **partial** representation of APM Hexseal's many product lines. Please contact us directly for additional product options, as well as to request a Quote or place an Order.



# APM Hexseal's High-Pressure Self-Sealing Fasteners

APM Hexseal holds the notable distinction of having designed and patented the very first self-sealing fasteners, which became our trademarked Seelskrews® and Seelbolts®. In addition to fastening, our self-sealing screws and bolts offer a reliable and reusable seal, preventing (or containing!) contamination from dust, air, water, lubricants and other liquid or gaseous substances. They are also vibration resistant, making them a great choice for applications that encounter day-to-day jarring, or repetitive movement. Should you need a more serious level of vibration resistance, our screws and bolts are available with locking features such as self-locking pellets, strips and patches. Some additional customizations include specialty thread-forming variations, tamper-resistant drives, thread captivation, as well as paint and finish options. Contact us for additional thread size and o-ring elastomer options.

## SEELSKREWS®

STANDARD FLAT HEAD † with CROSS RECESS DRIVE (PHILLIPS) – Type Code SFR							
Thread Size	Drive Size	Available Lengths (L) ‡	Max. Head Diameter (C)	Recommended Clearance Hole			
				Min. Diameter	Max. Diameter	Min. Depth	Max. Depth
2-56 UNC-2A	#1	1/4" to 1"	0.172"	0.091"	0.950"	0.036"	0.054"
4-40 UNC-2A	#1	1/4" to 1"	0.225"	0.125"	0.129"	0.050"	0.075"
6-32 UNC-2A	#2	1/4" to 1"	0.279"	0.147"	0.152"	0.063"	0.094"
8-32 UNC-2A	#2	1/4" to 1"	0.332"	0.173"	0.179"	0.063"	0.094"
10-24 UNC-2A	#2	5/16" to 1"	0.385"	0.199"	0.204"	0.083"	0.125"
10-32 UNF-2A	#2	5/16" to 1"	0.385"	0.199"	0.204"	0.063"	0.094"
1/4-20 UNC-2A	#3	3/8" to 1-1/4"	0.507"	0.265"	0.269"	0.100"	0.150"

See Figure 11

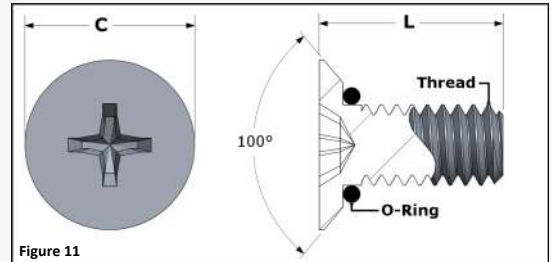

Figure 11

STANDARD PAN HEAD with SLOTTED DRIVE – Type Code S							
Thread Size	Available Lengths (L) ‡	Max. Head Diameter (C)	Max. Head Height (D)	Recommended Clearance Hole			
				Min. Diameter	Max. Diameter	Min. Depth	Max. Depth
2-56 UNC-2A	1/4" to 5/8"	0.168"	0.055"	0.091"	0.950"	0.036"	0.054"
4-40 UNC-2A	1/4" to 1"	0.220"	0.069"	0.125"	0.129"	0.050"	0.075"
6-32 UNC-2A	1/4" to 1"	0.271"	0.083"	0.147"	0.152"	0.063"	0.094"
8-32 UNC-2A	1/4" to 1"	0.323"	0.097"	0.173"	0.179"	0.063"	0.094"
10-32 UNF-2A	1/4" to 1"	0.374"	0.113"	0.199"	0.204"	0.063"	0.094"
10-24 UNC-2A	1/4" to 1"	0.374"	0.113"	0.199"	0.204"	0.083"	0.125"
1/4-20 UNC-2A	5/16" to 1-1/4"	0.493"	0.148"	0.265"	0.269"	0.100"	0.150"
1/4-28 UNF-2A	5/16" to 1-1/4"	0.493"	0.148"	0.265"	0.269"	0.071"	0.107"

See Figure 12

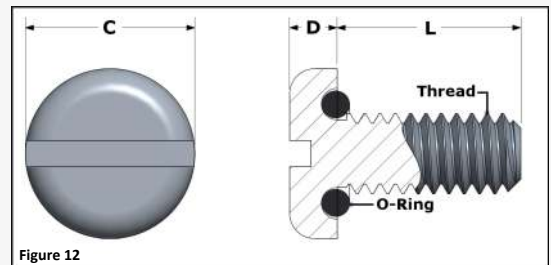

Figure 12

METRIC PAN HEAD with SLOTTED DRIVE – Type Code SM							
Thread Size	Available Lengths (L) ‡	Max. Head Diameter (C)	Max. Head Height (D)	Recommended Clearance Hole			
				Min. Diameter	Max. Diameter	Min. Depth	Max. Depth
M2 x 0.40 6g	4mm to 12mm	4.24mm	1.37mm	2.31mm	2.41mm	0.80mm	1.20mm
M2.5 x 0.45 6g	4mm to 12mm	5.56mm	1.73mm	2.67mm	2.84mm	0.90mm	1.35mm
M3 x 0.50 6g	4mm to 40mm	6.22mm	1.90mm	3.55mm	3.65mm	1.00mm	1.50mm
M4 x 0.70 6g	4mm to 40mm	8.17mm	2.43mm	4.39mm	4.54mm	1.40mm	2.10mm
M5 x 0.80 6g	6mm to 40mm	9.70mm	3.05mm	5.56mm	5.66mm	1.60mm	2.40mm
M6 x 1 6g	6mm to 50mm	12.49mm	3.73mm	6.73mm	6.83mm	2.00mm	3.00mm
M8 x 1.25 6g	6mm to 50mm	15.62mm	4.52mm	8.45mm	8.55mm	2.50mm	3.75mm

See Figure 13

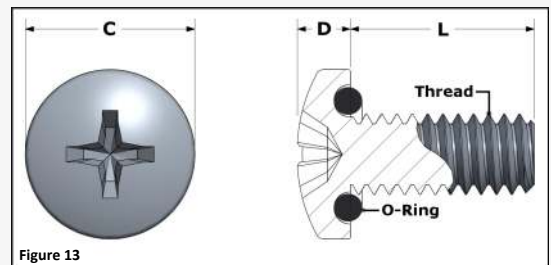

Figure 13

STANDARD PAN HEAD with CROSS RECESS DRIVE (PHILLIPS) – Type Code R								
Thread Size	Drive Size	Available Lengths (L) ‡	Max. Head Diameter (C)	Max. Head Height (D)	Recommended Clearance Hole			
					Min. Diameter	Max. Diameter	Min. Depth	Max. Depth
2-56 UNC-2A	#1	1/4" to 1"	0.181"	0.062"	0.091"	0.950"	0.036"	0.054"
4-40 UNC-2A	#1	1/4" to 1"	0.238"	0.080"	0.125"	0.129"	0.050"	0.075"
6-32 UNC-2A	#2	1/4" to 1"	0.294"	0.097"	0.147"	0.152"	0.063"	0.094"
8-32 UNC-2A	#2	1/4" to 1"	0.347"	0.115"	0.173"	0.179"	0.063"	0.094"
10-32 UNF-2A	#2	3/8" to 1"	0.403"	0.133"	0.199"	0.204"	0.063"	0.094"
10-24 UNC-2A	#2	3/8" to 1"	0.403"	0.133"	0.199"	0.204"	0.083"	0.125"
1/4-20 UNC-2A	#3	3/8" to 1-1/4"	0.517"	0.175"	0.265"	0.269"	0.100"	0.150"
1/4-28 UNF-2A	#3	3/8" to 1-1/4"	0.517"	0.175"	0.265"	0.269"	0.071"	0.107"

METRIC PAN HEAD with CROSS RECESS DRIVE (PHILLIPS) – Type Code RM								
Thread Size	Drive Size	Available Lengths (L) ‡	Max. Head Diameter (C)	Max. Head Height (D)	Recommended Clearance Hole			
					Min. Diameter	Max. Diameter	Min. Depth	Max. Depth
M2 X 0.40 6g	#1	4mm to 12mm	4.24mm	1.60mm	2.31mm	2.41mm	0.80mm	1.20mm
M2.5 X 0.45 6g	#1	4mm to 12mm	5.46mm	2.10mm	2.67mm	2.84mm	0.90mm	1.35mm
M3 X 0.50 6g	#2	4mm to 40mm	6.70mm	2.40mm	3.55mm	3.65mm	1.00mm	1.50mm
M4 X 0.70 6g	#2	4mm to 40mm	8.69mm	3.05mm	4.39mm	4.54mm	1.40mm	2.10mm
M5 X 0.80 6g	#2	6mm to 40mm	9.90mm	3.70mm	5.56mm	5.66mm	1.60mm	2.40mm
M6 X 1 6g	#3	6mm to 50mm	12.58mm	4.60mm	6.73mm	6.83mm	2.00mm	3.00mm

† Standard APM Hexseal Flat Head Seelskrews have a 100° head angle.  
 ‡ Available in increments of 1/16" up to 5/8" length, and 1/8" from 5/8" length up. Tolerance for lengths up to 1" is +0 -1/32". Tolerance above 1" is +0 -1/16".  
 § Available in increments of 2mm. Tolerance for lengths up to 25mm is +0 -0.8mm. Tolerance above 25mm is +0 -1.6mm.

This catalog is a partial representation of APM Hexseal's many product lines. Please contact us directly for additional product options, as well as to request a Quote or place an Order.



Tamper-Resistant Drive Styles			
STYLE VIEW			
STYLE NAME	6-Lobe Drive with Pin	Hex Drive with Pin	Spanner Drive
TYPE CODE	LBP	HP	SS

Contact us for more information on these, and other, drive options.

**SEELBOLTS®**

See Figure 14

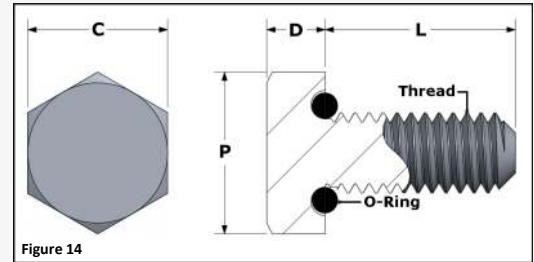
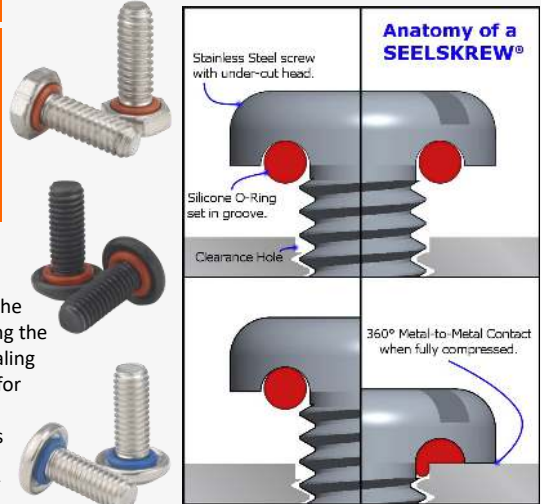

Figure 14

STANDARD HEXAGONAL HEAD BOLT – Type Code ST								
Thread Size	Min. Length Available (L)	Distance Between Flats (C)	Distance Between Points (P) ▲	Max. Head Height (D)	Recommended Clearance Hole			
					Min. Diameter	Max. Diameter	Min. Depth	Max. Depth
1/4-28 UNF-2A	3/8"	0.440"	0.510"	0.163"	0.265"	0.269"	0.071"	0.107"
1/4-20 UNC-2A	3/8"	0.440"	0.510"	0.163"	0.265"	0.269"	0.100"	0.150"
5/16-24 UNF-2A	1/2"	0.502"	0.580"	0.211"	0.332"	0.336"	0.083"	0.125"
5/16-18 UNC-2A	3/8"	0.502"	0.580"	0.211"	0.332"	0.336"	0.111"	0.167"
3/8-24 UNF-2A	5/8"	0.565"	0.650"	0.243"	0.395"	0.399"	0.083"	0.125"
3/8-16 UNC-2A	1/2"	0.565"	0.650"	0.243"	0.395"	0.399"	0.125"	0.188"
1/2-20 UNF-2A	1/2"	0.752"	0.870"	0.323"	0.530"	0.534"	0.100"	0.150"
1/2-13 UNC-2A	3/4"	0.752"	0.870"	0.323"	0.530"	0.534"	0.154"	0.231"

METRIC HEXAGONAL HEAD BOLT – Type Code STM								
Thread Size	Min. Length Available (L)	Distance Between Flats (C)	Distance Between Points (P) ▲	Max. Head Height (D)	Recommended Clearance Hole			
					Min. Diameter	Max. Diameter	Min. Depth	Max. Depth
M6 X 1.6g	8mm	10mm	11.28mm	4.15mm	6.73mm	6.83mm	2.00mm	3.00mm
M8 X 1.25 6g	12mm	13mm	14.69mm	5.65mm	8.45mm	8.55mm	2.50mm	3.75mm
M10 X 1.5 6g	12mm	17mm	19.25mm	7.18mm	10.53mm	10.64mm	3.00mm	4.50mm
M12 X 1.75 6g	20mm	19mm	21.50mm	8.18mm	12.79mm	12.9mm	3.50mm	5.25mm
M16 X 2 6g	20mm	24mm	27.23mm	10.18mm	17.52mm	17.63mm	4.00mm	6.00mm

▲ The "Distance Between Points" values are for reference only.



**APM Hexseal's High-Pressure Self-Sealing Nuts**

APM Hexseal's Seelnuts® are made from high quality rubber, molded into a specially shaped cavity in the nut itself. With threads molded directly into the rubber, these self-sealing nuts form a positive seal along the threaded section of the Seelnut, as well as with the contact surface, removing the need for gaskets, sealing compounds or extra surface preparation. Seelnuts install just like conventional nuts, and are designed for use with ordinary screws, bolts and studs, making them a quick and easy sealing option for all sorts of applications, especially where there is a need to withstand high internal or external pressures. Seelnuts are also reusable, meaning that they can be easily removed and reapplied, reestablishing the same reliable seal when torqued. Our Seelnuts are available in all standard thread sizes as well as a variety of different elastomers to suit your application needs. For applications where excessive vibration is an issue, Seelnuts can be supplied with self-locking pellets.

**SEELNUTS®**

See Figure 15

Thread Size	Height of Sealing Rib (R)	STANDARD NUTS – Type Code AJ		JAM NUTS – Type Code AJ MC	
		Distance Between Flats (C)	Max. Head Height (D)	Distance Between Flats (C)	Max. Head Height (D)
6-32 UNC-2B	1/64"	5/16"	9/64"	1/2"	7/32"
8-32 UNC-2B	1/64"	3/8"	5/32"	1/2"	7/32"
10-24 UNC-2B	1/64"	3/8"	5/32"	1/2"	7/32"
10-32 UNF-2B	1/64"	3/8"	5/32"	1/2"	7/32"
1/4-20 UNC-2B	1/64"	7/16"	7/32"	5/8"	7/32"
1/4-28 UNF-2B	1/64"	7/16"	7/32"	5/8"	7/32"
5/16-18 UNC-2B	1/64"	1/2"	17/64"	5/8"	7/32"
5/16-24 UNF-2B ♦	1/64"	1/2"	17/64"	5/8"	7/32"
3/8-16 UNC-2B	1/64"	9/16"	21/64"	5/8"	7/32"
3/8-24 UNF-2B	1/64"	9/16"	21/64"	5/8"	7/32"
7/16-20 UNF-2B	1/32"	11/16"	3/8"	N/A	N/A
1/2-13 UNC-2B	1/32"	3/4"	27/64"	3/4"	7/32"
1/2-20 UNF-2B	1/32"	3/4"	27/64"	3/4"	7/32"
5/8-18 UNF-2B	1/32"	15/16"	35/64"	N/A	N/A

♦ The Jam Nut material used for this thread size is Low Carbon Steel with Zinc-Chromate plating.

METRIC NUTS ★ – Type Code AJ			
Thread Size	Height of Sealing Rib (R)	Distance Between Flats (C)	Max. Head Height (D)
M3 x 0.5 6H	0.2mm	5.5mm	2.2mm
M4 x 0.7 6H	0.3mm	7.0mm	3.0mm
M5 x 0.8 6H	0.4mm	8.0mm	3.8mm
M6 x 1 6H	0.5mm	10.0mm	4.8mm
M8 x 1.25 6H	0.6mm	13.0mm	6.3mm
M10 x 1.5 6H	0.6mm	17.0mm	7.8mm
M12 x 1.75 6H	0.8mm	19.0mm	9.3mm
M14 x 2 6H	1.0mm	22.0mm	10.8mm

★ APM Hexseal's standard material for metric nuts is Stainless-Steel.

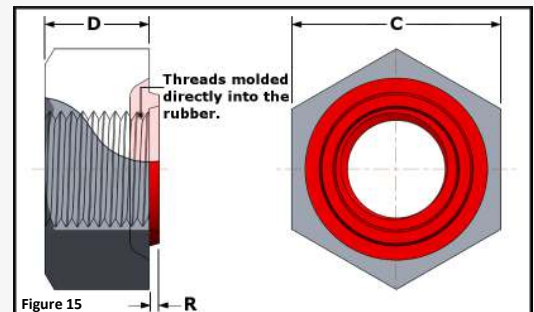

Figure 15

**MATERIAL SPECIFICATIONS**  
For APM Hexseal® Standard Seelnuts®

**Nut Material:** Low Carbon Steel with Zinc-Chromate Plating †  
**Threads:** Imperial— Class 2B ‡; Metric— Class 6H  
**Elastomer:** Silicone conforms to A-A-59588, Class 3A, GR60, Red ♦  
**Temperature Range:** -103° F to +400° F (-75° C to +204° C)  
**Pressure Range:** Up to 20,000 psig internal and external (subject to clearance hole dimensions).  
**Resistant to:** Splash, salt spray, sunlight, ozone, weather, fungus, dust, and most acids and lubricating oils.  
**Shelf Life:** Excess of 25 years.  
**Enclosure Protection:** IEC IP66 / IP68 •

† Standard Jam Nut material is Brass with Nickel Plating.  
 ‡ Standard for stock nuts.  
 ♦ Alternative elastomers are available by special order.  
 • A dual IP code rating indicates that both ratings apply.

APM Hexseal's UL and ULC Recognized Components conform to UL Standard 50. Contact us for a complete list of our Recognized Components and ratings.

**Ordering Instructions for Products with Type Codes – Seelskrews®, Seelbolts® & Seelnuts®**

The following information is **required** in order for our Sales Team to process any kind of Purchase Order or Request for Quote:

- 1) Indicate the desired **Type Code** (Type Codes are short series' of letters that can be found in corresponding parts tables)
- 2) Specify the desired **Thread Size** as listed in the parts table
- 3) Specify the **Length**, if applicable
- 4) Specify the desired **O-Ring Material**, if applicable (Please see **Elastomer Options for APM Hexseal® O-Rings** on page 7)

Any additions, such as alternate materials, finish options and locking features, should be discussed with a Sales Associate at the time of order.

This catalog is a **partial** representation of APM Hexseal's many product lines. Please contact us directly for additional product options, as well as to request a Quote or place an Order.



## APM Hexseal Air-Tight Sealing Washers

APM Hexseal's Seeloc® Washers consist of molded silicone rubber bonded to specially formed stainless steel washers. Designed to be used in conjunction with conventional screws, bolts or studs, Seeloc Washers are a simple sealing solution that is ideal for all sorts of applications, especially where spray, vapors or wash-downs are present, or where there is concern of contamination from dust, oils or salt build-up. The silicone contact surface features a continuous ridge which, upon compression, creates a 360° sealing barrier around the periphery of the washer face. The silicone rubber also forms a seal under the head of the associated fastener and makes full vertical contact with the threads/shank, making for a complete, high-pressure seal unlike any other. Seeloc Washers can be used over conventional mounting holes, extra-large holes, or even oddly shaped adjustment slots. Their reusability make them perfect for applications that might require periodic maintenance or adjustments.



MATERIAL SPECIFICATIONS	
For APM Hexseal® Standard Seeloc® Washers	
<b>Washer Material:</b>	18/8 Stainless Steel
<b>Elastomer:</b>	Silicone † conforms to A-A-59588, Class 3A, GR50, Green ‡
<b>Temperature Range:</b>	-103° F to +400° F ( -75° C to +204° C)
<b>Pressure Range:</b>	Up to 100 psig internal and external.
<b>Resistant to:</b>	Splash, salt spray, sunlight, ozone, weather, fungus, dust, and most acids and lubricating oils.
<b>Shelf Life:</b>	Excess of 25 years.
<b>Enclosure Protection:</b>	IEC IP66 / IP68 ◊

† Alternative materials are available. Consult Elastomer Options table below.  
 ‡ Standard color for Metric Seeloc Washers is red. Alternative colors are available by special order.  
 ◊ A dual IP code rating indicates that both ratings apply.

APM Hexseal's UL and ULC Recognized Components conform to UL Standard 50. Contact us for a complete list of our Recognized Components and ratings.

Can't find the fastener you need?



**ASK US!**

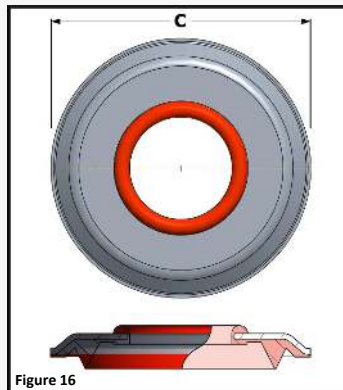

Figure 16

If we do not already have what you are looking for, we can MAKE IT! Contact us for more information.

## APM Hexseal's Available Elastomers

**Cautionary Note:** These tables are to be used as a guide ONLY. The information provided does not take into account the possible variations that can, and do, exist from one application to another, and thus cannot be relied upon as definite. APM Hexseal strongly recommends that the material you select be rigorously tested in the actual application in order to independently verify that the material is well suited for your particular installation or use.

### Elastomer Options for APM Hexseal® Sealing Boots, Bushings, Seelnuts® & Seeloc® Washers

KEY	
<b>A</b>	→ Recommended
<b>B</b>	→ Fair / Satisfactory
<b>C</b>	→ Acceptable / Poor
<b>U</b>	→ Unsatisfactory

Compound Letter & Code	Material Name	Relevant Specifications	Service Temp. in °F	Service Temp. in °C	RESISTANCE				TYPICAL PROPERTIES			
					Ozone	Chemicals	Petroleum Oil	Soap Solutions	Tensile PSI	Elongation %	Abrasion Resistance	Compression Set
S 2701	Silicone	A-A-59588, Class 3A, GR30, GR50, GR60 ▲	-103° to +400°	-75° to +204°	A	B	U	A	500-1800	100-800	A	A
L 2615	FluoroSilicone	MIL-DTL-25988 (B), Type 2, Class 1, GR60	-70° to +392°	-57° to +200°	A	B	A	A	600-1400	100-700	C	A
N 4601	Buna N (Nitrile)	ASTM D2000 60 Durometer	-22° to +212°	-30° to +100°	C	C	A	A	1500-3000	400-600	A	B
E 3601	Neoprene	ASTM D2000 60 Durometer	-40° to +257°	-40° to +121°	B	C	B	A	1500-4000	100-700	B	C
F 7601	EPDM (Ethylene Propylene)	ASTM D2000 70 Durometer	-60° to +300°	-51° to +149°	A	U	U	A	1400-1600	500-600	B	A

▲ Various durometer and color options available. Please contact us for more information.

### Elastomer Options for APM Hexseal® O-Rings

Compound Letter & Code	Material Name	Relevant Specifications	Service Temp. in °F	Service Temp. in °C	RESISTANCE				TYPICAL PROPERTIES			
					Ozone	Chemicals	Petroleum Oil	Soap Solutions	Tensile PSI	Elongation %	Abrasion Resistance	Compression Set
S 2701	Silicone	A-A-59588, Class 2, GR60 or GR70	-80° to +425°	-62° to +219°	A	B	U	A	500-1800	100-800	A	A
L 2615	Fluoro-Silicone	MIL-DTL-25988C, Type 1, Class 1, GR60 or GR70	-70° to +392°	-57° to +200°	A	B	A	A	600-1400	100-700	B	A
V 5701	Viton® A ♦	ASTM D2000 75 Durometer	-15° to +400°	-26° to +205°	A	A	A	A	2000-2200	300-400	C	B
N 4601	Buna N (Nitrile)	ASTM D2000 70 Durometer	-30° to +250°	-34° to +121°	C	C	A	A	1500-3000	400-600	A	B
E 3601	Neoprene	ASTM D2000 70 Durometer	-35° to +225°	-37° to +107°	B	C	B	A	1500-4000	100-700	B	C
F 7601	EPDM (Ethylene Propylene)	ASTM D2000 70 Durometer	-70° to +250°	-57° to +121°	A	U	U	A	1400-1600	500-600	B	A

♦ Viton® is a registered trademark of DuPont Performance Elastomers.

This catalog is a **partial** representation of APM Hexseal's many product lines. Please contact us directly for additional product options, as well as to request a Quote or place an Order.



Suitability of APM Hexseal® Products to Customer Application

The information contained in APM Hexseal literature, website, drawings, etc., is offered in good faith and is believed to be accurate. Since APM Hexseal cannot foresee or control the varied conditions under which this information and/or APM Hexseal products may be used, APM Hexseal does not guarantee the applicability of this information, or the suitability of APM Hexseal products. Customers are expected to perform their own evaluation to determine the suitability of APM Hexseal products for their specific purposes and applications.

# ALL NEW PRODUCTS FROM APM HEXSEAL®

## SNAPSEEL® BOOT for PUSHBUTTON SWITCHES

Compatible with Cole Hersee Momentary Switches

### Part # 1211/71 12 Kit

Kit includes Snapseel® boot and 5/8-32 UN-2B shouldered mounting nut.



## HEAVY DUTY SEELOC® WASHERS

Capable of withstanding at LEAST 50% higher torque values than our original Seeloc® Washers.



### Part # Series 75XXX HD

Currently available in 1/2" and 1" Outer Diameter sizes.

Contact us for size options and availability.



ISO 9001:2015 Registered



(800) 498-9034  
www.apmhexseal.com

## Looking for pricing, stock, or lifecycle information?

Click below to explore more details on WIN SOURCE:

 [View 75107 on WIN SOURCE](#)

 [APM Hexseal Information](#)

## Optimize Your Supply Chain with WIN SOURCE Solutions

-  Global Sourcing Solution
-  Obsolete Management
-  Cost Control Management
-  Shortage Management
-  Alternative Solution
-  Excess Inventory Management