



**THE DATASHEET OF
74HC74PW-Q100,118**



74HC74-Q100; 74HCT74-Q100

Dual D-type flip-flop with set and reset; positive edge-trigger

Rev. 5 — 2 April 2024

Product data sheet

1. General description

The 74HC74-Q100; 74HCT74-Q100 are dual positive edge triggered D-type flip-flop with individual data (nD), clock (nCP), set (nSD) and reset (nRD) inputs, and complementary nQ and nQ outputs. Data at the nD-input, that meets the set-up and hold time requirements on the LOW-to-HIGH clock transition, will be stored in the flip-flop and appear at the nQ output. The Schmitt-trigger action in the clock input, makes the circuit highly tolerant to slower clock rise and fall times. Inputs include clamp diodes. This enables the use of current limiting resistors to interface inputs to voltages in excess of V_{CC} .

This product has been qualified to the Automotive Electronics Council (AEC) standard Q100 (Grade 1) and is suitable for use in automotive applications.

2. Features and benefits

- Automotive product qualification in accordance with AEC-Q100 (Grade 1)
 - Specified from -40 °C to +85 °C and from -40 °C to +125 °C
- Input levels:
 - For 74HC74-Q100: CMOS level
 - For 74HCT74-Q100: TTL level
- Symmetrical output impedance
- Low power dissipation
- High noise immunity
- Balanced propagation delays
- Specified in compliance with JEDEC standard no. 7A
- ESD protection:
 - HBM: ANSI/ESDA/JEDEC JS-001 class 2 exceeds 2000 V
 - CDM: ANSI/ESDA/JEDEC JS-002 class C3 exceeds 1000 V
- Multiple package options
- DHVQFN package with Side-Wettable Flanks enabling Automatic Optical Inspection (AOI) of solder joints

3. Ordering information

Table 1. Ordering information

| Type number | Package | | | Version |
|---|-------------------|----------|--|--------------------------|
| | Temperature range | Name | Description | |
| 74HC74D-Q100 74HCT74D-Q100 | -40 °C to +125 °C | SO14 | plastic small outline package; 14 leads; body width 3.9 mm | SOT108-1 |
| 74HC74PW-Q100 74HCT74PW-Q100 | -40 °C to +125 °C | TSSOP14 | plastic thin shrink small outline package; 14 leads; body width 4.4 mm | SOT402-1 |
| 74HC74BQ-Q100 74HCT74BQ-Q100 | -40 °C to +125 °C | DHVQFN14 | plastic dual in-line compatible thermal enhanced very thin quad flat package; no leads; 14 terminals; body 2.5 × 3 × 0.85 mm | SOT762-1 |

4. Functional diagram

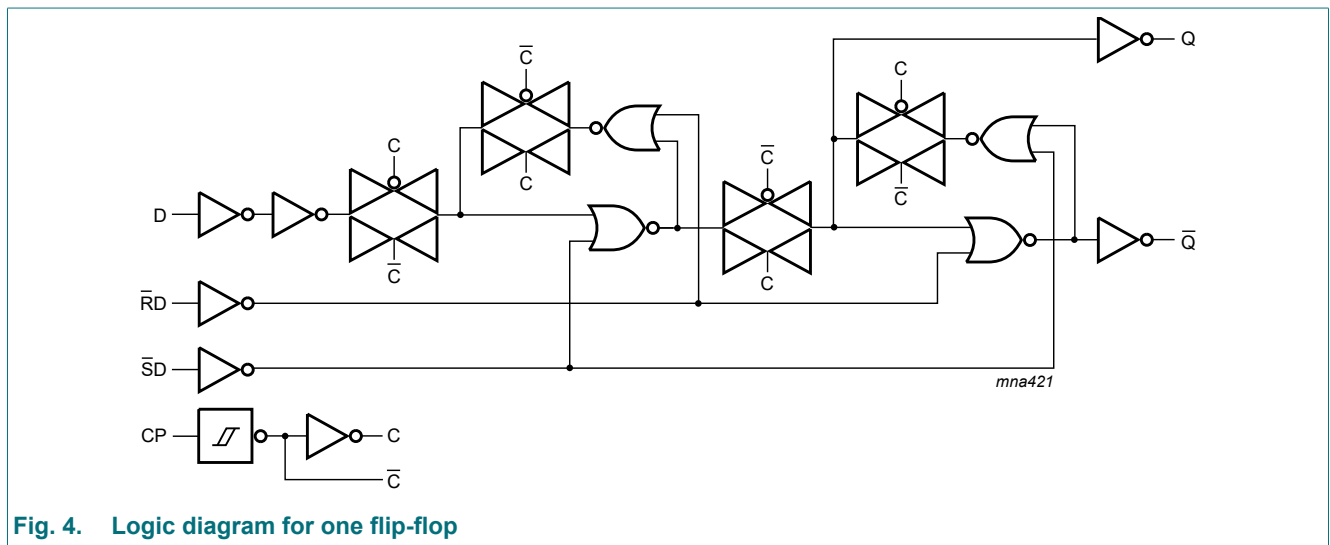
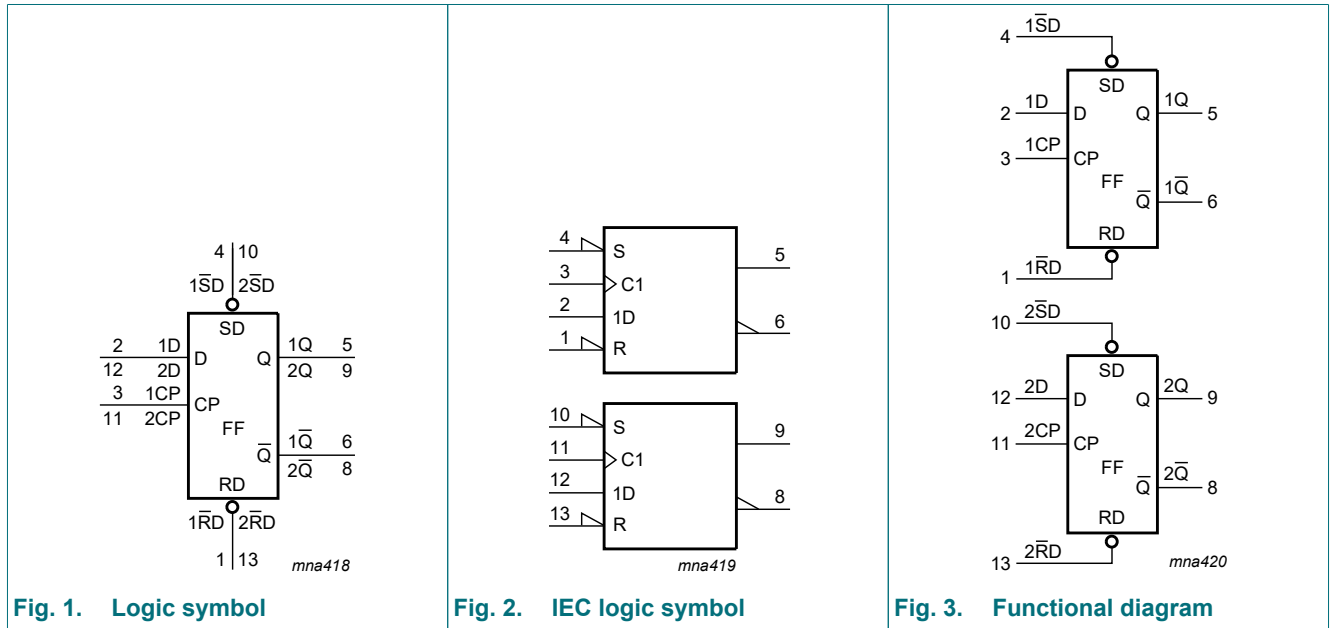

5. Pinning information

5.1. Pinning

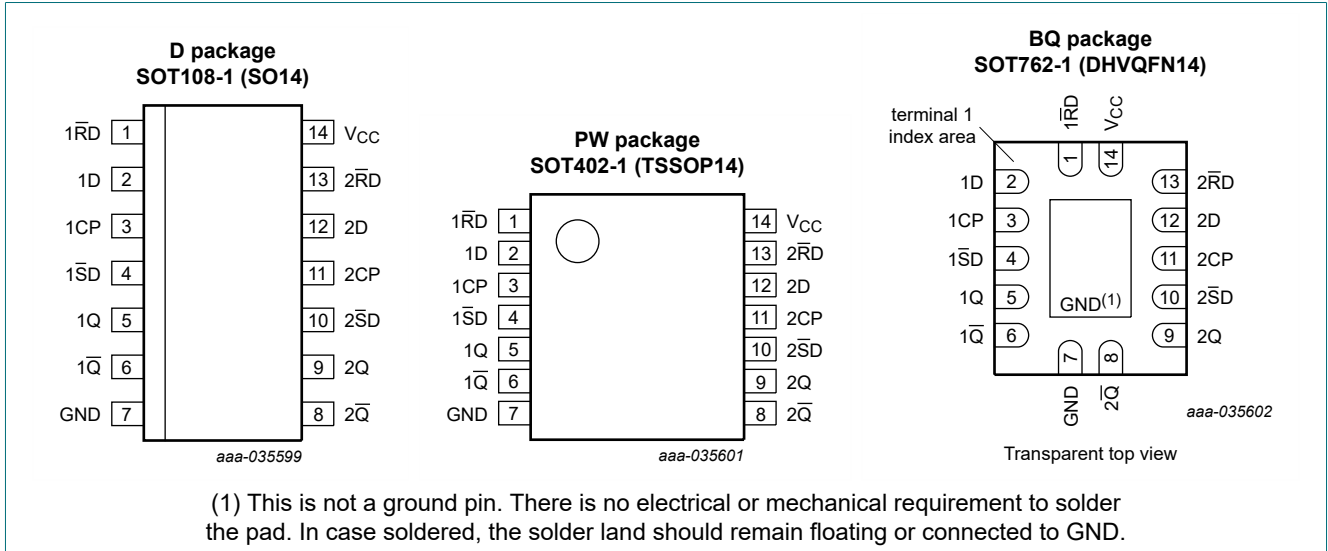

5.2. Pin description

Table 2. Pin description

| Symbol | Pin | Description |
|--------|-----|--|
| 1RD | 1 | asynchronous reset-direct input (active LOW) |
| 1D | 2 | data input |
| 1CP | 3 | clock input (LOW-to-HIGH, edge-triggered) |
| 1SD | 4 | asynchronous set-direct input (active LOW) |
| 1Q | 5 | output |
| 1Q | 6 | complement output |
| GND | 7 | ground (0 V) |
| 2Q | 8 | complement output |
| 2Q | 9 | output |
| 2SD | 10 | asynchronous set-direct input (active LOW) |
| 2CP | 11 | clock input (LOW-to-HIGH, edge-triggered) |
| 2D | 12 | data input |
| 2RD | 13 | asynchronous reset-direct input (active LOW) |
| VCC | 14 | supply voltage |

6. Functional description

Table 3. Function table

H = HIGH voltage level; L = LOW voltage level; X = don't care.

| Input | | | | Output | |
|-------|-----|-----|----|--------|-----|
| nSD | nRD | nCP | nD | nQ | nQ̄ |
| L | H | X | X | H | L |
| H | L | X | X | L | H |
| L | L | X | X | H | H |

Table 4. Function table

H = HIGH voltage level; L = LOW voltage level; X = don't care;

↑ = LOW-to-HIGH transition; Q_{n+1} = state after the next LOW-to-HIGH CP transition.

| Input | | | | Output | |
|-------|-----|-----|----|-------------------|--------------------|
| nSD | nRD | nCP | nD | nQ _{n+1} | nQ̄ _{n+1} |
| H | H | ↑ | L | L | H |
| H | H | ↑ | H | H | L |

7. Limiting values

Table 5. Limiting values

In accordance with the Absolute Maximum Rating System (IEC 60134). Voltages are referenced to GND (ground = 0 V).

| Symbol | Parameter | Conditions | Min | Max | Unit |
|------------------|-------------------------|--|------|------|------|
| V _{CC} | supply voltage | | -0.5 | +7 | V |
| I _{IK} | input clamping current | V _I < -0.5 V or V _I > V _{CC} + 0.5 V | - | ±20 | mA |
| I _{OK} | output clamping current | V _O < -0.5 V or V _O > V _{CC} + 0.5 V | - | ±20 | mA |
| I _O | output current | V _O = -0.5 V to (V _{CC} + 0.5 V) | - | ±25 | mA |
| I _{CC} | supply current | | - | +100 | mA |
| I _{GND} | ground current | | -100 | - | mA |
| T _{stg} | storage temperature | | -65 | +150 | °C |
| P _{tot} | total power dissipation | T _{amb} = -40 °C to +125 °C SOT108-1 (SO14) SOT402-1 (TSSOP14) SOT762-1 (DHVQFN14) | - | 500 | mW |

[1] For SOT108-1 (SO14) package: P_{tot} derates linearly with 10.1 mW/K above 100 °C.

[2] For SOT402-1 (TSSOP14) package: P_{tot} derates linearly with 7.3 mW/K above 81 °C.

[3] For SOT762-1 (DHVQFN14) package: P_{tot} derates linearly with 9.6 mW/K above 98 °C.

8. Recommended operating conditions

Table 6. Recommended operating conditions

Voltages are referenced to GND (ground = 0 V)

| Symbol | Parameter | Conditions | 74HC74-Q100 | | | 74HCT74-Q100 | | | Unit |
|---------------------|-------------------------------------|-------------------------|-------------|------|----------|--------------|------|----------|------|
| | | | Min | Typ | Max | Min | Typ | Max | |
| V_{CC} | supply voltage | | 2.0 | 5.0 | 6.0 | 4.5 | 5.0 | 5.5 | V |
| V_I | input voltage | | 0 | - | V_{CC} | 0 | - | V_{CC} | V |
| V_O | output voltage | | 0 | - | V_{CC} | 0 | - | V_{CC} | V |
| T_{amb} | ambient temperature | | -40 | +25 | +125 | -40 | +25 | +125 | °C |
| $\Delta t/\Delta V$ | input transition rise and fall rate | $V_{CC} = 2.0\text{ V}$ | - | - | 625 | - | - | - | ns/V |
| | | $V_{CC} = 4.5\text{ V}$ | - | 1.67 | 139 | - | 1.67 | 139 | ns/V |
| | | $V_{CC} = 6.0\text{ V}$ | - | - | 83 | - | - | - | ns/V |

9. Static characteristics

Table 7. Static characteristics

At recommended operating conditions; voltages are referenced to GND (ground = 0 V).

| Symbol | Parameter | Conditions | -40 °C to +85 °C | | | -40 °C to +125 °C | | Unit |
|---------------------|---------------------------|--|------------------|---------|------|-------------------|------|------|
| | | | Min | Typ [1] | Max | Min | Max | |
| 74HC74-Q100 | | | | | | | | |
| V _{IH} | HIGH-level input voltage | V _{CC} = 2.0 V | 1.5 | 1.2 | - | 1.5 | - | V |
| | | V _{CC} = 4.5 V | 3.15 | 2.4 | - | 3.15 | - | V |
| | | V _{CC} = 6.0 V | 4.2 | 3.2 | - | 4.2 | - | V |
| V _{IL} | LOW-level input voltage | V _{CC} = 2.0 V | - | 0.8 | 0.5 | - | 0.5 | V |
| | | V _{CC} = 4.5 V | - | 2.1 | 1.35 | - | 1.35 | V |
| | | V _{CC} = 6.0 V | - | 2.8 | 1.8 | - | 1.8 | V |
| V _{OH} | HIGH-level output voltage | V _I = V _{IH} or V _{IL} | | | | | | |
| | | I _O = -4.0 mA; V _{CC} = 4.5 V | 3.84 | 4.32 | - | 3.7 | - | V |
| | | I _O = -5.2 mA; V _{CC} = 6.0 V | 5.34 | 5.81 | - | 5.2 | - | V |
| V _{OL} | LOW-level output voltage | V _I = V _{IH} or V _{IL} | | | | | | |
| | | I _O = 4.0 mA; V _{CC} = 4.5 V | - | 0.15 | 0.33 | - | 0.4 | V |
| | | I _O = 5.2 mA; V _{CC} = 6.0 V | - | 0.16 | 0.33 | - | 0.4 | V |
| I _I | input leakage current | V _I = V _{CC} or GND; V _{CC} = 6.0 V | - | - | ±1.0 | - | ±1.0 | µA |
| I _{CC} | supply current | V _I = V _{CC} or GND; I _O = 0 A; V _{CC} = 6.0 V | - | - | 40 | - | 80 | µA |
| C _I | input capacitance | | - | 3.5 | - | - | - | pF |
| 74HCT74-Q100 | | | | | | | | |
| V _{IH} | HIGH-level input voltage | V _{CC} = 4.5 V to 5.5 V | 2.0 | 1.6 | - | 2.0 | - | V |
| V _{IL} | LOW-level input voltage | V _{CC} = 4.5 V to 5.5 V | - | 1.2 | 0.8 | - | 0.8 | V |
| V _{OH} | HIGH-level output voltage | V _I = V _{IH} or V _{IL} ; V _{CC} = 4.5 V | | | | | | |
| | | I _O = -4 mA | 3.84 | 4.32 | - | 3.7 | - | V |
| V _{OL} | LOW-level output voltage | V _I = V _{IH} or V _{IL} ; V _{CC} = 4.5 V | | | | | | |
| | | I _O = 4.0 mA | - | 0.15 | 0.33 | - | 0.4 | V |
| I _I | input leakage current | V _I = V _{CC} or GND; V _{CC} = 5.5 V | - | - | ±1.0 | - | ±1.0 | µA |
| I _{CC} | supply current | V _I = V _{CC} or GND; I _O = 0 A; V _{CC} = 5.5 V | - | - | 40 | - | 80 | µA |
| ΔI _{CC} | additional supply current | V _I = V _{CC} - 2.1 V; other inputs at V _{CC} or GND; V _{CC} = 4.5 V to 5.5 V; I _O = 0 A | | | | | | |
| | | per input pin; nD, nRD inputs | - | 70 | 315 | - | 343 | µA |
| | | per input pin; nSD, nCP input | - | 80 | 360 | - | 392 | µA |
| C _I | input capacitance | | - | 3.5 | - | - | - | pF |

[1] All typical values are measured at T_{amb} = 25 °C.

10. Dynamic characteristics

Table 8. Dynamic characteristics

Voltages are referenced to GND (ground = 0 V); $C_L = 50$ pF unless otherwise specified; for test circuit see Fig. 7.

| Symbol | Parameter | Conditions | -40 °C to +85 °C | | | -40 °C to +125 °C | | Unit |
|--------------------|-------------------|--|------------------|---------|-----|-------------------|-----|------|
| | | | Min | Typ [1] | Max | Min | Max | |
| 74HC74-Q100 | | | | | | | | |
| t_{pd} | propagation delay | nCP to nQ, n \bar{Q} ; see Fig. 5 [2] | | | | | | |
| | | $V_{CC} = 2.0$ V | - | 47 | 220 | - | 265 | ns |
| | | $V_{CC} = 4.5$ V | - | 17 | 44 | - | 53 | ns |
| | | $V_{CC} = 5$ V; $C_L = 15$ pF | - | 14 | - | - | - | ns |
| | | $V_{CC} = 6.0$ V | - | 14 | 37 | - | 45 | ns |
| | | n $\bar{S}D$ to nQ, n \bar{Q} ; see Fig. 6 [2] | | | | | | |
| | | $V_{CC} = 2.0$ V | - | 50 | 250 | - | 300 | ns |
| | | $V_{CC} = 4.5$ V | - | 18 | 50 | - | 60 | ns |
| | | $V_{CC} = 5$ V; $C_L = 15$ pF | - | 15 | - | - | - | ns |
| | | $V_{CC} = 6.0$ V | - | 14 | 43 | - | 51 | ns |
| | | n $\bar{R}D$ to nQ, n \bar{Q} ; see Fig. 6 [2] | | | | | | |
| | | $V_{CC} = 2.0$ V | - | 52 | 250 | - | 300 | ns |
| | | $V_{CC} = 4.5$ V | - | 19 | 50 | - | 60 | ns |
| | | $V_{CC} = 5$ V; $C_L = 15$ pF | - | 16 | - | - | - | ns |
| $V_{CC} = 6.0$ V | - | 15 | 43 | - | 51 | ns | | |
| t_t | transition time | nQ, n \bar{Q} ; see Fig. 5 [3] | | | | | | |
| | | $V_{CC} = 2.0$ V | - | 19 | 95 | - | 110 | ns |
| | | $V_{CC} = 4.5$ V | - | 7 | 19 | - | 22 | ns |
| | | $V_{CC} = 6.0$ V | - | 6 | 16 | - | 19 | ns |
| t_w | pulse width | nCP HIGH or LOW; see Fig. 5 | | | | | | |
| | | $V_{CC} = 2.0$ V | 100 | 19 | - | 120 | - | ns |
| | | $V_{CC} = 4.5$ V | 20 | 7 | - | 24 | - | ns |
| | | $V_{CC} = 6.0$ V | 17 | 6 | - | 20 | - | ns |
| | | n $\bar{S}D$, n $\bar{R}D$ LOW; see Fig. 6 | | | | | | |
| | | $V_{CC} = 2.0$ V | 100 | 19 | - | 120 | - | ns |
| | | $V_{CC} = 4.5$ V | 20 | 7 | - | 24 | - | ns |
| $V_{CC} = 6.0$ V | 17 | 6 | - | 20 | - | ns | | |
| t_{rec} | recovery time | n $\bar{S}D$, n $\bar{R}D$; see Fig. 6 | | | | | | |
| | | $V_{CC} = 2.0$ V | 40 | 3 | - | 45 | - | ns |
| | | $V_{CC} = 4.5$ V | 8 | 1 | - | 9 | - | ns |
| | | $V_{CC} = 6.0$ V | 7 | 1 | - | 8 | - | ns |

Dual D-type flip-flop with set and reset; positive edge-trigger

| Symbol | Parameter | Conditions | -40 °C to +85 °C | | | -40 °C to +125 °C | | Unit |
|------------------|-------------------------------|---|------------------|---------|-----|-------------------|-----|------|
| | | | Min | Typ [1] | Max | Min | Max | |
| t _{su} | set-up time | nD to nCP; see Fig. 5 | | | | | | |
| | | V _{CC} = 2.0 V | 75 | 6 | - | 90 | - | ns |
| | | V _{CC} = 4.5 V | 15 | 2 | - | 18 | - | ns |
| | | V _{CC} = 6.0 V | 13 | 2 | - | 15 | - | ns |
| t _h | hold time | nD to nCP; see Fig. 5 | | | | | | |
| | | V _{CC} = 2.0 V | 3 | -6 | - | 3 | - | ns |
| | | V _{CC} = 4.5 V | 3 | -2 | - | 3 | - | ns |
| | | V _{CC} = 6.0 V | 3 | -2 | - | 3 | - | ns |
| f _{max} | maximum frequency | nCP; see Fig. 5 | | | | | | |
| | | V _{CC} = 2.0 V | 4.8 | 23 | - | 4.0 | - | MHz |
| | | V _{CC} = 4.5 V | 24 | 69 | - | 20 | - | MHz |
| | | V _{CC} = 5 V; C _L = 15 pF | - | 76 | - | - | - | MHz |
| | | V _{CC} = 6.0 V | 28 | 82 | - | 24 | - | MHz |
| C _{PD} | power dissipation capacitance | C _L = 50 pF; f = 1 MHz; V _I = GND to V _{CC} [4] | - | 24 | - | - | - | pF |

Dual D-type flip-flop with set and reset; positive edge-trigger

| Symbol | Parameter | Conditions | -40 °C to +85 °C | | | -40 °C to +125 °C | | Unit |
|---------------------|-------------------------------|--|------------------|---------|-----|-------------------|-----|------|
| | | | Min | Typ [1] | Max | Min | Max | |
| 74HCT74-Q100 | | | | | | | | |
| t _{pd} | propagation delay | nCP to nQ, nQ̄; see Fig. 5 [2] | | | | | | |
| | | V _{CC} = 4.5 V | - | 18 | 44 | - | 53 | ns |
| | | V _{CC} = 5 V; C _L = 15 pF | - | 15 | - | - | - | ns |
| | | nSD to nQ, nQ̄; see Fig. 6 [2] | | | | | | |
| | | V _{CC} = 4.5 V | - | 23 | 50 | - | 60 | ns |
| | | V _{CC} = 5 V; C _L = 15 pF | - | 18 | - | - | - | ns |
| | | nRD to nQ, nQ̄; see Fig. 6 [2] | | | | | | |
| | | V _{CC} = 4.5 V | - | 24 | 50 | - | 60 | ns |
| t _t | transition time | nQ, nQ̄; see Fig. 5 [3] | | | | | | |
| | | V _{CC} = 4.5 V | - | 7 | 19 | - | 22 | ns |
| t _w | pulse width | nCP HIGH or LOW; see Fig. 5 | | | | | | |
| | | V _{CC} = 4.5 V | 23 | 9 | - | 27 | - | ns |
| | | nSD, nRD LOW; see Fig. 6 | | | | | | |
| | | V _{CC} = 4.5 V | 20 | 9 | - | 24 | - | ns |
| t _{rec} | recovery time | nSD, nRD; see Fig. 6 | | | | | | |
| | | V _{CC} = 4.5 V | 8 | 1 | - | 9 | - | ns |
| t _{su} | set-up time | nD to nCP; see Fig. 5 | | | | | | |
| | | V _{CC} = 4.5 V | 15 | 5 | - | 18 | - | ns |
| t _h | hold time | nD to nCP; see Fig. 5 | | | | | | |
| | | V _{CC} = 4.5 V | 3 | -3 | - | 3 | - | ns |
| f _{max} | maximum frequency | nCP; see Fig. 5 | | | | | | |
| | | V _{CC} = 4.5 V | 22 | 54 | - | 18 | - | MHz |
| | | V _{CC} = 5 V; C _L = 15 pF | - | 59 | - | - | - | MHz |
| C _{PD} | power dissipation capacitance | C _L = 50 pF; f = 1 MHz; V _I = GND to V _{CC} - 1.5 V [4] | - | 29 | - | - | - | pF |

- [1] All typical values are measured at T_{amb} = 25 °C.
- [2] t_{pd} is the same as t_{PLH} and t_{PHL}.
- [3] t_t is the same as t_{THL} and t_{TLH}.
- [4] C_{PD} is used to determine the dynamic power dissipation (P_D in μW).
 $P_D = C_{PD} \times V_{CC}^2 \times f_i \times N + \Sigma(C_L \times V_{CC}^2 \times f_o)$ where:
 f_i = input frequency in MHz;
 f_o = output frequency in MHz;
 C_L = output load capacitance in pF;
 V_{CC} = supply voltage in V;
 N = number of inputs switching;
 $\Sigma(C_L \times V_{CC}^2 \times f_o)$ = sum of outputs.

10.1. Waveforms and test circuit

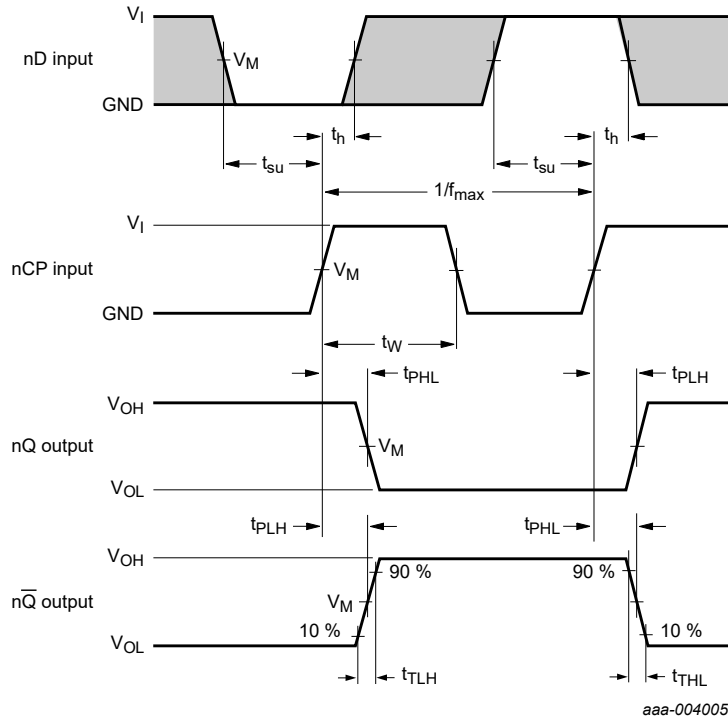

aaa-004005

Measurement points are given in [Table 9](#).

V_{OL} and V_{OH} are typical voltage output levels that occur with the output load.

Fig. 5. Propagation delay input (CP) to output (Qn), output transition time, clock input (CP) pulse width and the maximum frequency (CP)

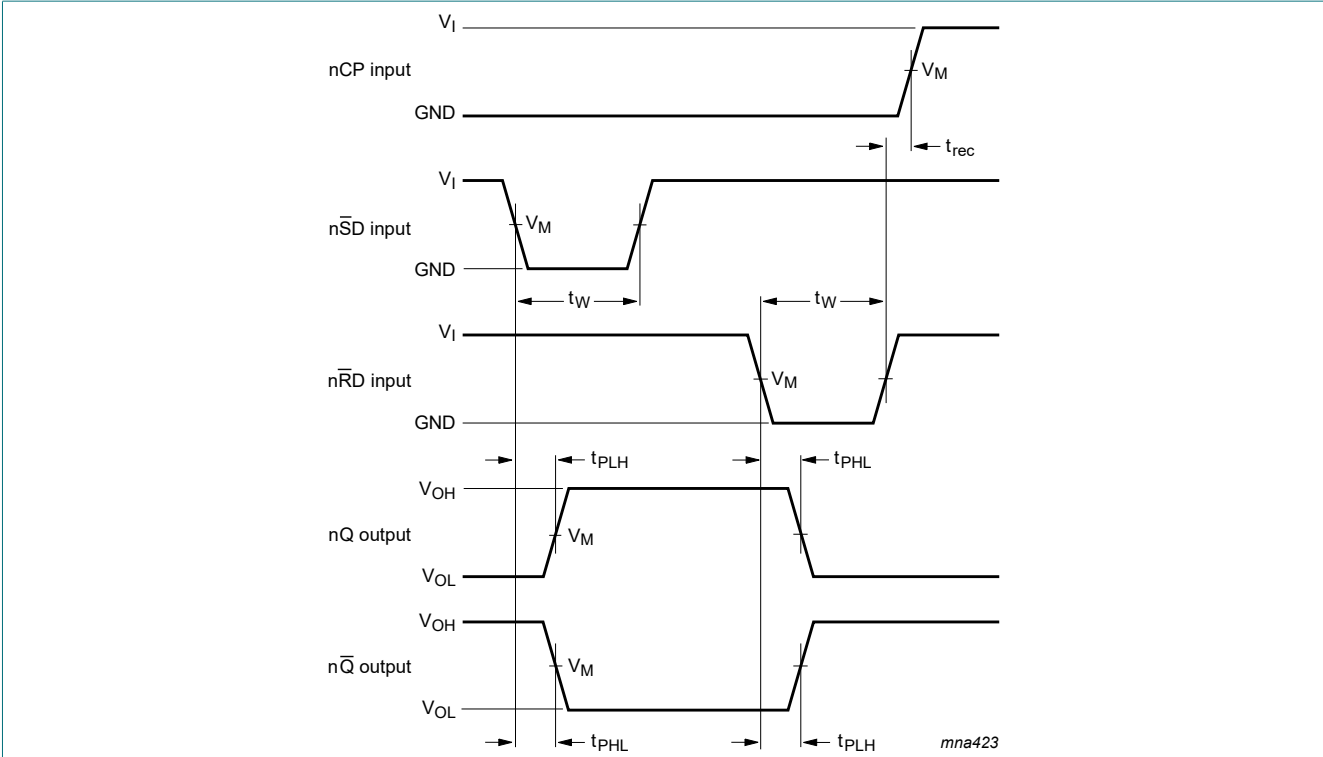

Measurement points are given in [Table 9](#).

V_{OL} and V_{OH} are typical voltage output levels that occur with the output load.

Fig. 6. The set ($n\bar{SD}$) and reset ($n\bar{RD}$) input to output ($nQ, n\bar{Q}$) propagation delays, set and reset pulse widths and the $n\bar{SD}, n\bar{RD}$ to nCP recovery time

Table 9. Measurement points

| Type | Input | Output |
|--------------|-------------|-------------|
| | V_M | V_M |
| 74HC74-Q100 | $0.5V_{CC}$ | $0.5V_{CC}$ |
| 74HCT74-Q100 | 1.3 V | 1.3 V |

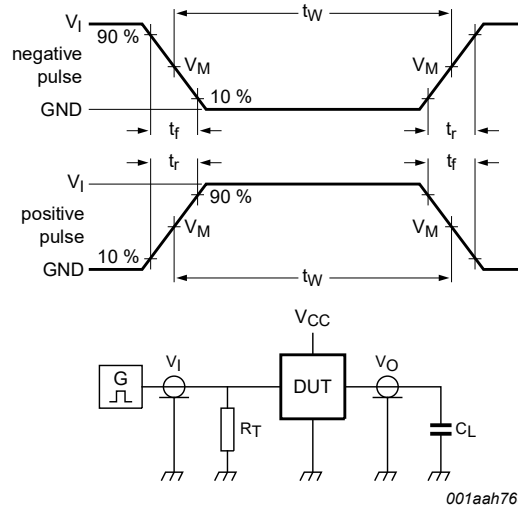

Test data is given in [Table 10](#).

Definitions test circuit:

R_T = Termination resistance should be equal to output impedance Z_o of the pulse generator.

C_L = Load capacitance including jig and probe capacitance.

R_L = Load resistance.

S1 = Test selection switch.

Fig. 7. Test circuit for measuring switching times

Table 10. Test data

| Type | Input | | Load | | Test |
|--------------|----------|------------|--------------|--------------|--------------------|
| | V_I | t_r, t_f | C_L | R_L | |
| 74HC74-Q100 | V_{CC} | 6 ns | 15 pF, 50 pF | 1 k Ω | t_{PLH}, t_{PHL} |
| 74HCT74-Q100 | 3 V | 6 ns | 15 pF, 50 pF | 1 k Ω | t_{PLH}, t_{PHL} |

11. Package outline

SO14: plastic small outline package; 14 leads; body width 3.9 mm

SOT108-1

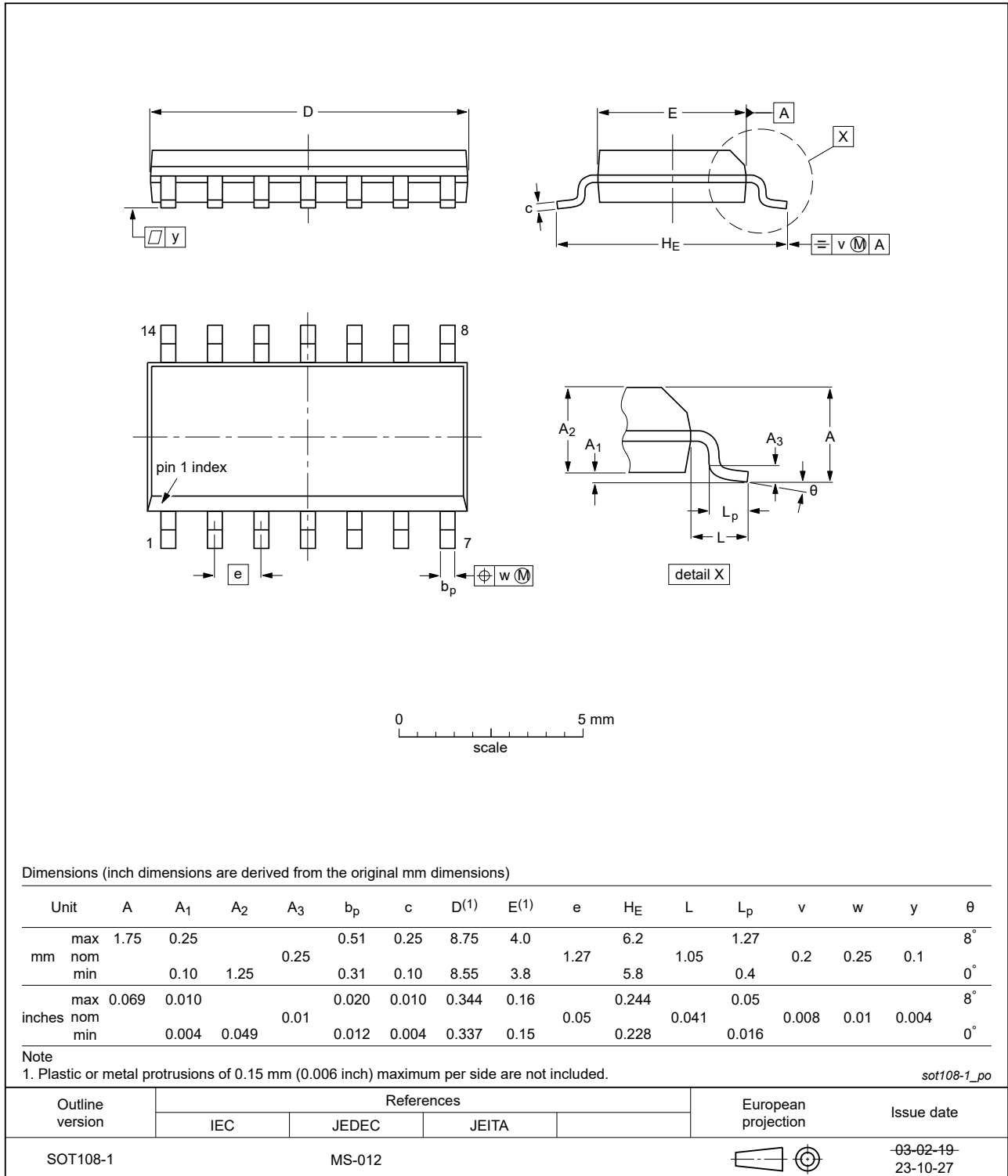

Fig. 8. Package outline SOT108-1 (SO14)

TSSOP14: plastic thin shrink small outline package; 14 leads; body width 4.4 mm

SOT402-1

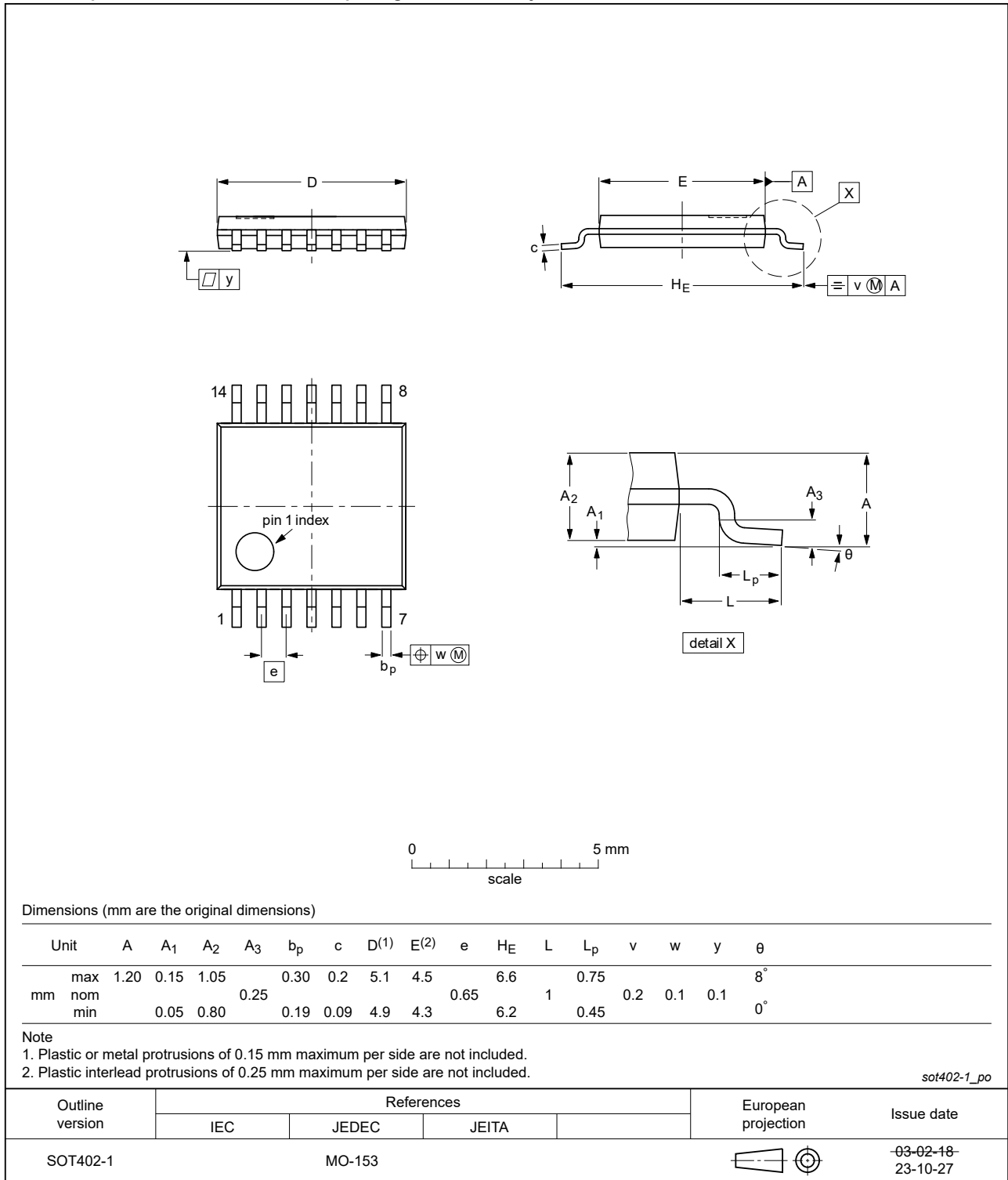

Fig. 9. Package outline SOT402-1 (TSSOP14)

DHVQFN14: plastic dual in-line compatible thermal enhanced very thin quad flat package; no leads; 14 terminals; body 2.5 x 3 x 0.85 mm

SOT762-1

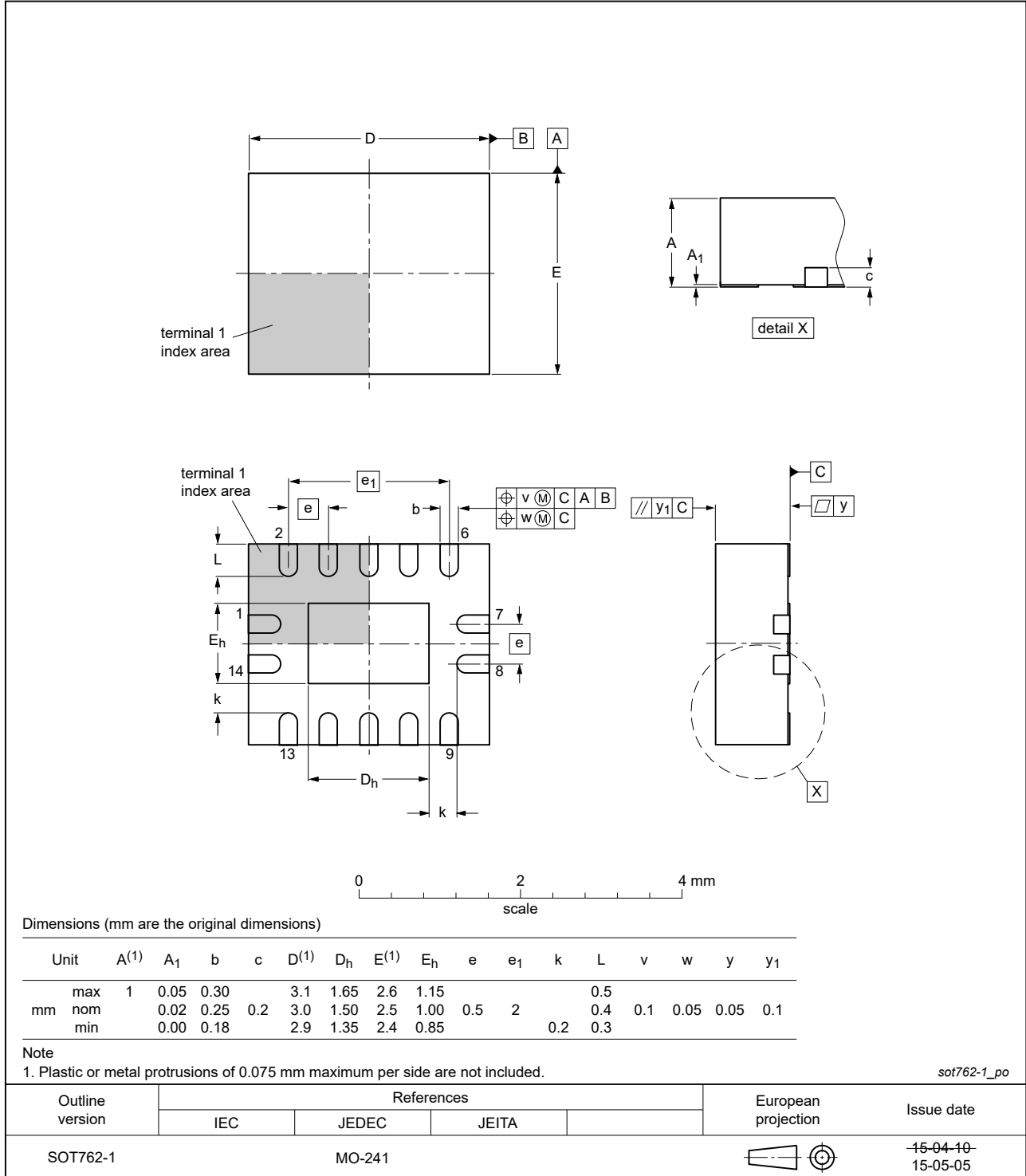

Fig. 10. Package outline SOT762-1 (DHVQFN14)

12. Abbreviations

Table 11. Abbreviations

| Acronym | Description |
|---------|---|
| CDM | Charged Device Model |
| CMOS | Complementary Metal Oxide Semiconductor |
| ESD | ElectroStatic Discharge |
| HBM | Human Body Model |
| TTL | Transistor-Transistor Logic |

13. Revision history

Table 12. Revision history

| Document ID | Release date | Data sheet status | Change notice | Supersedes |
|---------------------|---|--------------------|---------------|---------------------|
| 74HC_HCT74_Q100 v.5 | 20240402 | Product data sheet | - | 74HC_HCT74_Q100 v.4 |
| Modifications: | <ul style="list-style-type: none"> • Fig. 8, Fig. 9: Aligned SO and TSSOP package outline drawings to JEDEC MS-012 and MO-153. • Section 2: ESD specification updated according to the latest JEDEC standard. | | | |
| 74HC_HCT74_Q100 v.4 | 20200421 | Product data sheet | - | 74HC_HCT74_Q100 v.3 |
| Modifications: | <ul style="list-style-type: none"> • The format of this data sheet has been redesigned to comply with the identity guidelines of Nexperia. • Legal texts have been adapted to the new company name where appropriate. • Section 2 updated. • Table 5: Derating values for P_{tot} total power dissipation updated. | | | |
| 74HC_HCT74_Q100 v.3 | 20151204 | Product data sheet | - | 74HC_HCT74_Q100 v.2 |
| Modifications: | <ul style="list-style-type: none"> • Type number 74HC74N-Q100 (SOT27-1) removed. | | | |
| 74HC_HCT74_Q100 v.2 | 20130906 | Product data sheet | - | 74HC_HCT74_Q100 v.1 |
| Modifications: | <ul style="list-style-type: none"> • 74HC74N-Q100 (DIP14) added. | | | |
| 74HC_HCT74_Q100 v.1 | 20120807 | Product data sheet | - | - |

14. Legal information

Data sheet status

| Document status [1][2] | Product status [3] | Definition |
|--------------------------------|--------------------|---|
| Objective [short] data sheet | Development | This document contains data from the objective specification for product development. |
| Preliminary [short] data sheet | Qualification | This document contains data from the preliminary specification. |
| Product [short] data sheet | Production | This document contains the product specification. |

- [1] Please consult the most recently issued document before initiating or completing a design.
- [2] The term 'short data sheet' is explained in section "Definitions".
- [3] The product status of device(s) described in this document may have changed since this document was published and may differ in case of multiple devices. The latest product status information is available on the internet at <https://www.nexperia.com>.

Definitions

Draft — The document is a draft version only. The content is still under internal review and subject to formal approval, which may result in modifications or additions. Nexperia does not give any representations or warranties as to the accuracy or completeness of information included herein and shall have no liability for the consequences of use of such information.

Short data sheet — A short data sheet is an extract from a full data sheet with the same product type number(s) and title. A short data sheet is intended for quick reference only and should not be relied upon to contain detailed and full information. For detailed and full information see the relevant full data sheet, which is available on request via the local Nexperia sales office. In case of any inconsistency or conflict with the short data sheet, the full data sheet shall prevail.

Product specification — The information and data provided in a Product data sheet shall define the specification of the product as agreed between Nexperia and its customer, unless Nexperia and customer have explicitly agreed otherwise in writing. In no event however, shall an agreement be valid in which the Nexperia product is deemed to offer functions and qualities beyond those described in the Product data sheet.

Disclaimers

Limited warranty and liability — Information in this document is believed to be accurate and reliable. However, Nexperia does not give any representations or warranties, expressed or implied, as to the accuracy or completeness of such information and shall have no liability for the consequences of use of such information. Nexperia takes no responsibility for the content in this document if provided by an information source outside of Nexperia.

In no event shall Nexperia be liable for any indirect, incidental, punitive, special or consequential damages (including - without limitation - lost profits, lost savings, business interruption, costs related to the removal or replacement of any products or rework charges) whether or not such damages are based on tort (including negligence), warranty, breach of contract or any other legal theory.

Notwithstanding any damages that customer might incur for any reason whatsoever, Nexperia's aggregate and cumulative liability towards customer for the products described herein shall be limited in accordance with the Terms and conditions of commercial sale of Nexperia.

Right to make changes — Nexperia reserves the right to make changes to information published in this document, including without limitation specifications and product descriptions, at any time and without notice. This document supersedes and replaces all information supplied prior to the publication hereof.

Suitability for use in automotive applications — This Nexperia product has been qualified for use in automotive applications. Unless otherwise agreed in writing, the product is not designed, authorized or warranted to be suitable for use in life support, life-critical or safety-critical systems or

equipment, nor in applications where failure or malfunction of an Nexperia product can reasonably be expected to result in personal injury, death or severe property or environmental damage. Nexperia and its suppliers accept no liability for inclusion and/or use of Nexperia products in such equipment or applications and therefore such inclusion and/or use is at the customer's own risk.

Quick reference data — The Quick reference data is an extract of the product data given in the Limiting values and Characteristics sections of this document, and as such is not complete, exhaustive or legally binding.

Applications — Applications that are described herein for any of these products are for illustrative purposes only. Nexperia makes no representation or warranty that such applications will be suitable for the specified use without further testing or modification.

Customers are responsible for the design and operation of their applications and products using Nexperia products, and Nexperia accepts no liability for any assistance with applications or customer product design. It is customer's sole responsibility to determine whether the Nexperia product is suitable and fit for the customer's applications and products planned, as well as for the planned application and use of customer's third party customer(s). Customers should provide appropriate design and operating safeguards to minimize the risks associated with their applications and products.

Nexperia does not accept any liability related to any default, damage, costs or problem which is based on any weakness or default in the customer's applications or products, or the application or use by customer's third party customer(s). Customer is responsible for doing all necessary testing for the customer's applications and products using Nexperia products in order to avoid a default of the applications and the products or of the application or use by customer's third party customer(s). Nexperia does not accept any liability in this respect.

Limiting values — Stress above one or more limiting values (as defined in the Absolute Maximum Ratings System of IEC 60134) will cause permanent damage to the device. Limiting values are stress ratings only and (proper) operation of the device at these or any other conditions above those given in the Recommended operating conditions section (if present) or the Characteristics sections of this document is not warranted. Constant or repeated exposure to limiting values will permanently and irreversibly affect the quality and reliability of the device.

Terms and conditions of commercial sale — Nexperia products are sold subject to the general terms and conditions of commercial sale, as published at <http://www.nexperia.com/profile/terms>, unless otherwise agreed in a valid written individual agreement. In case an individual agreement is concluded only the terms and conditions of the respective agreement shall apply. Nexperia hereby expressly objects to applying the customer's general terms and conditions with regard to the purchase of Nexperia products by customer.

No offer to sell or license — Nothing in this document may be interpreted or construed as an offer to sell products that is open for acceptance or the grant, conveyance or implication of any license under any copyrights, patents or other industrial or intellectual property rights.

Export control — This document as well as the item(s) described herein may be subject to export control regulations. Export might require a prior authorization from competent authorities.

Translations — A non-English (translated) version of a document is for reference only. The English version shall prevail in case of any discrepancy between the translated and English versions.

Trademarks

Notice: All referenced brands, product names, service names and trademarks are the property of their respective owners.

Contents

| | |
|--|-----------|
| 1. General description | 1 |
| 2. Features and benefits | 1 |
| 3. Ordering information | 1 |
| 4. Functional diagram | 2 |
| 5. Pinning information | 3 |
| 5.1. Pinning..... | 3 |
| 5.2. Pin description..... | 3 |
| 6. Functional description | 4 |
| 7. Limiting values | 4 |
| 8. Recommended operating conditions | 5 |
| 9. Static characteristics | 6 |
| 10. Dynamic characteristics | 7 |
| 10.1. Waveforms and test circuit..... | 10 |
| 11. Package outline | 13 |
| 12. Abbreviations | 16 |
| 13. Revision history | 16 |
| 14. Legal information | 17 |

© Nexperia B.V. 2024. All rights reserved

For more information, please visit: <http://www.nexperia.com>
For sales office addresses, please send an email to: salesaddresses@nexperia.com
Date of release: 2 April 2024

Looking for pricing, stock, or lifecycle information?

Click below to explore more details on WIN SOURCE:

- [View 74HC74PW-Q100,118 on WIN SOURCE](#)
- [Nexperia USA Inc. Information](#)

Optimize Your Supply Chain with WIN SOURCE Solutions

- ✓ Global Sourcing Solution
- ✓ Obsolete Management
- ✓ Cost Control Management
- ✓ Shortage Management
- ✓ Alternative Solution
- ✓ Excess Inventory Management