



**THE DATASHEET OF**  
**60601**



# High Output Overhead Ionizer Installation, Operation and Maintenance



Made in the  
United States of America

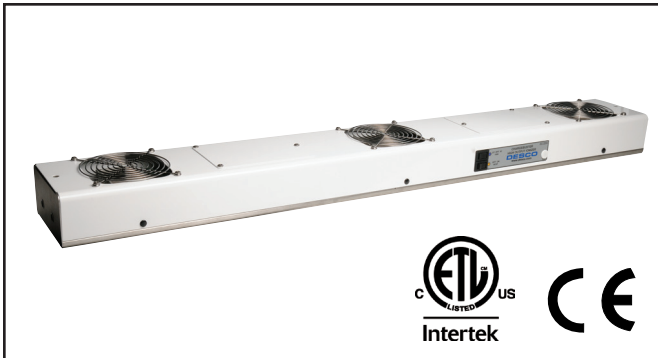

Figure 1. Desco [60601](#) High Output Overhead Ionizer

## Description

The Desco 40" High Output Overhead Ionizer is designed to neutralize electrostatic charges over a large work area. The unique active feedback and balance circuit automatically ensures and maintains the unit's ion offset voltage balance, despite variations in line voltage, air speed or emitter electrode condition. The ionizer's feedback circuit also gives an audible and visual alarm indication when a circuit malfunction has been detected. The overhead mounting design of this ionizer allows it to provide maximum coverage without consuming valuable work bench space. The need for maintenance is minimized, while maximum neutralization efficiency and overall performance is attained.

This overhead ionizer is unique - it comes equipped with two factory installed lights and a heater. The lights are on continuously whenever the ionizer is turned on and allow for better vision at the workstation. The heater is activated by a switch on the face of the ionizer. The heater will raise the ambient temperature by about 10°F. The heater is intended to only offset the chill factor of the moving air. It is not intended to warm the workstation.

Ionizers are useful in preventing electrostatic charge generation, ElectroStatic Discharge, ElectroStatic Attraction, as well as preventing equipment latch-up and safety related shock. Per ANSI/ESDS20.20-2007 section 8.3 "In order to mitigate field-induced CDM [Charged Device Model] damage, the ESD program shall include a plan for the handling of process-required insulators. If the field exceeds 2,000 volts/inch, steps shall be taken to either: A) Separate the insulator from the ESD-sensitive device by a distance of 30 cm (12 inches); or B) Use ionization or other charge mitigating techniques to neutralize the charge."

Ionization is used to neutralize charges on process necessary insulators and isolated semiconductors. Some examples of process necessary insulators are: the PC board itself, plastic test stands, plastic housing where a PCB may be mounted, as well as computer monitor screens and regular cleaning wipes. Examples of floating

or isolated conductors are: loaded PCB mounted in a stand where the pins are not contacting the dissipative workstation. Ionization is not effective on items that have large capacitance, like people and carts; however, ionizers should be considered as a method for charge neutralization in cases where grounding cannot be achieved.

"Ionizers should be considered as a method for charge neutralization in cases where grounding cannot be achieved." ... "Air ionization can neutralize the static charge on insulated and isolated objects by producing separate charges in the molecules of the gases of the surrounding air. When a static charge is present on objects in the work environment, it will be neutralized by attracting opposite polarity charges from the ionized air." (EN 61340-5-2 paragraph 5.2.9)

This ionizer is NIST calibrated and comes equipped with universal IEC cord connectors.

Item	Voltage / Hz	Light & Heater	IEC Cord
<a href="#">60601</a>	120 / 50-60	Yes	7' 6"

## IONIZER SELECTION

ANSI/ESD S20.20 paragraph 6.1.1.2. ESD Control Program Plan Guidance states: "The Plan should include a listing of the specific type of ESD protective materials and equipment used in the Program." When selecting an ionizer life cycle costs should be considered including: equipment cost, installation cost, and operation and maintenance cost.

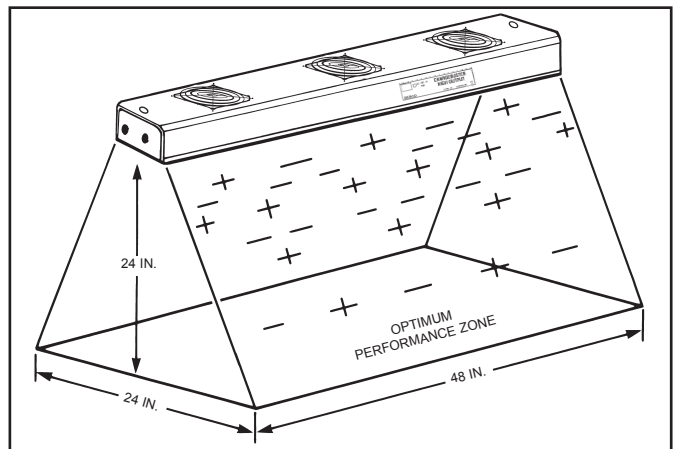

Figure 2. Area of optimum charge neutralization

The unit provides better coverage without using excessive bench space. The ionizer's discharge times (neutralization efficiency) is optimal at approximately 12" to 24" above the work surface, and will drop off as the distance from the unit increases.

**\*Never use incandescent lamps in the ionizer. Contact Desco Customer Service at (909) 627-8178 for lamp replacement information.**

## Installation

Figure 3 shows multiple mounting positions relative to the bench top. Mounting may be accomplished by brackets from shelving, vertical uprights, lights, or with chains hung from the ceiling. Ensure that air flow is not impeded by the method used.

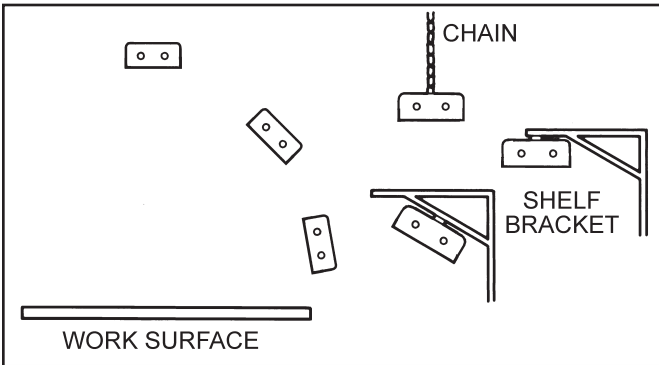

Figure 3. Mounting alternatives relative to the bench top

## Mounting Suggestions

Mounting the ionizer is facilitated by five 1/4"-20 threaded holes on each end and universal brackets supplied with the unit. To avoid a potential shock hazard, be sure that fasteners do not extend more than 1/2" into unit.

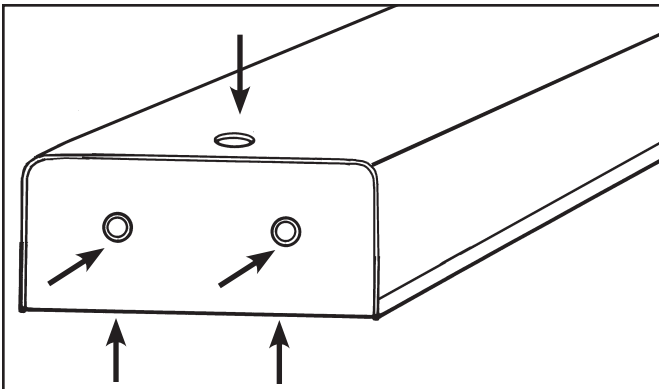

Figure 4. 1/4"-20 threaded mounting holes

## Filter for Ionizer (Optional)

A filter is available for the High Output Overhead Ionizer. Overhead ionizers operate more effectively when the air is free of contaminants. The filter will allow the overhead ionizer to operate longer between maintenance intervals. Ensure that ionizer is turned off. Remove grills and install filters on the ionizer using screws supplied (do not re-install grills over filters). Replacement filters are available as Desco item# [60455](#). For more information on the filter, call our customer service department at 909-627-8178 (Chino, CA) or 781-821-8370 (Canton, MA).

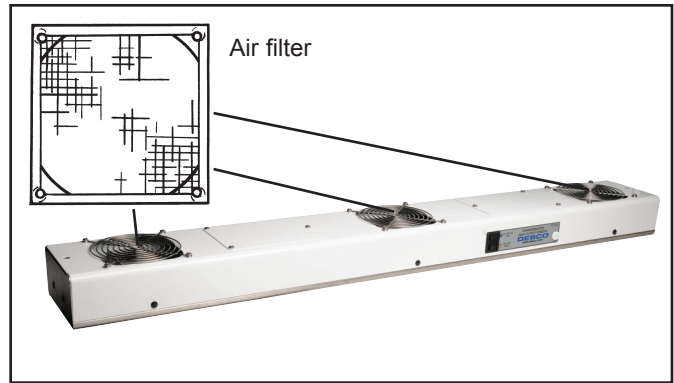

Figure 5. Filter for ionizer

## Operation

After the ionizer has been securely mounted, connect the power cord to the IEC connector on the back of the unit and then to a convenient grounded receptacle. It is recommended that the AC outlet be checked for proper wiring and grounding, as the ionizer depends on a good ground for offset voltage balancing.

Set the front panel rocker fan switch to either "HIGH" or "LOW" speed fan. Higher air flow will result in a faster neutralization rate.

**If the ionizer is used in a manner not specified by the manufacturer, the protection provided by the ionizer may be impaired.**

## Maintenance

"As with all ionizers, periodic maintenance will be needed to provide optimum performance." (Reference: IEC 61340-5-2:1paragraph 5.2.9).

The frequency of monitoring ionizers really depends on how and where they are used. Since the majority of them use a fan to transport the ions to the working area, the cleanliness of the air directly affects their performance over time and how often the emitters should be cleaned.

ANSI/ESD S20.20 specifies that the compliance verification of ionizers be tested per ESD TR53. EIA-625 recommends checking ionizers every 6 months, but this may not be suitable for many programs particularly since an out-of-balance may exist for months before it is checked again. ANSI/ESD S20.20 paragraph 6.1.3.1 Compliance Verification Plan Requirement states: "Test equipment shall be selected to make measurements of appropriate properties of the technical requirements that are incorporated into the ESD program plan." And paragraph 6.1.3.2. Compliance Verification Plan Guidance states: "In addition to internal audits, external audits (Organization and supplier of ESDS items) should be performed to ensure compliance with planned requirements. Verifications should include routine checks of the Technical Requirements in the Plan. The frequency of verification checks should be based on the control item usage, its durability and associated risk of failure."

Under normal conditions the ionizer will attract dirt and dust (especially on the emitter and fan guards). To maintain optimum performance, cleaning must be done on a regular basis. The emitter pins should be cleaned at least every 6 months. However, more frequent cleaning may be required if used in environments with more contaminants.

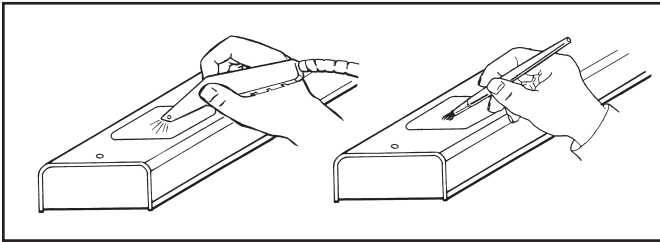

Figure 6. Cleaning the emitters and fan guards

Emitter pin cleaning is very simple and should be done frequently. **TURN THE IONIZER OFF.** Blow off contaminants on the emitter assemblies and fan guards with clean dry air.

If the ionizer does not return to proper balance, then you may need to clean each emitter point more thoroughly. **TURN THE UNIT OFF AND DISCONNECT THE POWER CORD.** With a non-linting swab or small brush dipped in isopropyl alcohol wipe each emitter needle thoroughly.

Brush off emitters to assure that stray filaments of cleaning material are completely removed. A soft cloth and alcohol may be used to clean each fan guard.

### Emitter Needle Replacement

The tri-metallic emitters should not require replacement unless broken or damaged. Contact Desco if replacement is required.

### Light Bulb Replacement

The High Output Overhead Ionizer features two fluorescent light bulbs. They can be accessed and replaced by removing the two covers located at the top of the ionizer. The light bulbs should only be replaced by the same compact fluorescent bulbs, 15 W max. **NOTE:** Never use incandescent lamps in the High Output Overhead Ionizer.

### Neutralization Efficiency (Discharge Times)

The comparative efficiency of overhead top ionizers is determined by a standard test published by the ESD Association Standard ANSI/ESD S3.1. The typical discharge times measured using this standard for the ionizer are shown in the following diagram. The performance of the ionizer was measured with the unit positioned at varying distances with the fan speed on high and without a filter.

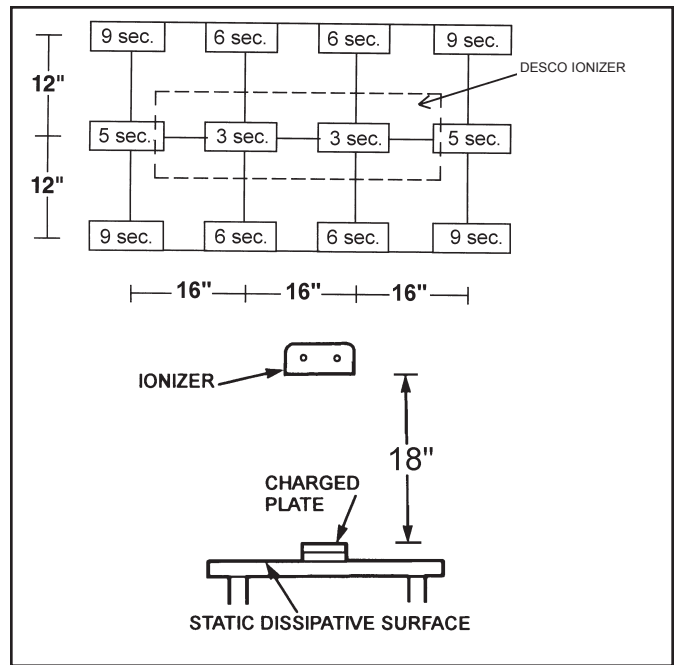

Figure 7. Discharge times in seconds from  $\pm 1000$  volts to  $\pm 100$  volts on a 6" x 6" charged plate per ANSI/ESD S3.1

### Theory of Operation

By definition, materials that are insulators cannot have static charges removed via grounding as they do not conduct electricity. Ionizer emitters flood an area with millions of positive and negative charged ions to neutralize statically charged insulators.

Desco overhead ionizers employ a safe non-nuclear Steady-State DC ionization source. Steady DC systems consist of separate negative and positive ion emitters connected by a pair of high-voltage cables to their respective high-voltage power supplies. The ionizer's unique, closed loop monitoring circuitry monitors ion output and automatically adjusts the unit to reach an equilibrium at perfectly balanced ion flow. The ionizer is designed to achieve balance under extreme conditions and is uniquely able to maintain balance in almost any environment. Desco ionizers meet the ANSI/ESD S20.20 less than  $\pm 50$  volts required limits offset voltage tested in accordance with ANSI ESD S3.1. High Output Overhead Ionizers greatly exceed the requirement providing  $\pm 15$  volt auto balancing.

The unit's circuitry also features a visual alarm, which alerts the user of malfunction conditions caused by excessive electrode contamination or the failure of either the positive or negative power supply. When the High Output Overhead Ionizer is ON and its output is balanced, the blue LED indicator on the front of the unit will be steadily lit. If a malfunction condition is detected the balance circuit will cause the blue LED to flash until the problem is corrected. See the maintenance section for recommended maintenance procedures.

The High Output Overhead Ionizer's quiet and gentle fan is designed so that it will not disturb personnel, paperwork, or delicate parts. The LED indicator mounted on the face of the unit allows the operator to easily verify whether it is ON, OFF, or in need of maintenance. The ionizer's emitter pin material will not require replacement during the normal life of the product.

The High Output Overhead Ionizer is engineered for efficiency and durability. The unit's automatic feedback balancing circuitry eliminates the need for repeated calibration, making this ionizer highly dependable and cost effective.

## Specifications

Input:	120 VAC - 50/60 Hz, 3A
Ozone:	Less than 0.05 ppm
Airflow:	150-260CFM adjustable
Dimensions:	40"L x 5-1/4"W x 2-3/4"H
Weight:	9.70 lbs
Cord:	7'6" cord set with IEC connector
Mounting:	Five each 1/4"-20 threaded holes on each end

## Testing and Calibration

We recommend at least annual calibration of our ionizers. Ionizers are tested and calibrated using a charged plate analyzer or an ionization test kit (ANSI/ESD SP33). ANSI/ESD S20.20 specifies that the compliance verification of ionizers be tested per ESD TR53. Standards may be obtained from the ESD Association, 7902 Turin Road, Suite 4, Rome, NY 13440-2069, (315) 339-6937. Desco will be happy to send you information on our model 19497 Ionization Test Kit.

The High Output Overhead Ionizer is calibrated to NIST traceable standards. Contact our Customer Service Department for details.

## Adjustments

For Audio On/Off and Alarm and Balance Adjustment see Figure 8.

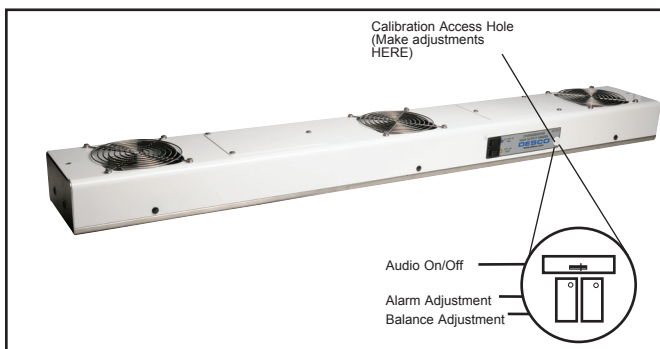

Figure 8. Audio On/Off and Alarm and Balance Adjustment of High Output Overhead Ionizer.

## Health

There are no known health risks associated with our devices. The emitters work at about 4-6 kV and can create ozone, but there have been no significant measurement of ozone from our emitter sets, as all our existing units test well below the OSHA limit of 0.05 ppm ozone. For additional safety information, see "Dispelling an Old Myth" written by William Metz of Hewlett-Packard published in Evaluation Engineering magazine, September 2001.

## Limited Warranty

Desco expressly warrants that for a period of one (1) year from the date of purchase, Desco Overhead Ionizers will be free of defects in material (parts) and workmanship (labor). Within the warranty period, a unit will be tested, repaired or replaced at Desco's option, free of charge. Call Customer Service at 909-627-8178 (Chino, CA) or 781-821-8370 (Canton, MA) for Return Material Authorization (RMA) and proper shipping instructions and address. You should include a copy of your original packing slip, invoice, or other proof of purchase date. Any unit under warranty should be shipped prepaid to the Desco factory. Warranty repairs will take approximately two weeks.

If your unit is out of warranty, Desco will quote repair charges necessary to bring your unit to factory standards. Call Customer Service at 909-627-8178 (Chino, CA) or 781-821-8370 (Canton, MA) for Return Material Authorization (RMA) and proper shipping instructions and address. Ship your unit freight prepaid.

## Warranty Exclusions

THE FOREGOING EXPRESS WARRANTY IS MADE IN LIEU OF ALL OTHER PRODUCT WARRANTIES, EXPRESSED AND IMPLIED, INCLUDING MERCHANTABILITY AND FITNESS FOR A PARTICULAR PURPOSE WHICH ARE SPECIFICALLY DISCLAIMED. The express warranty will not apply to defects or damage due to accidents, neglect, misuse, alterations, operator error, or failure to properly maintain, clean or repair products.

## Limit of Liability

Electronic ionizers use high voltage corona discharge and should not be used in or near flammable or explosive environments. In no event will Desco or any seller be responsible or liable for any injury, loss or damage, direct or consequential, arising out of the use of or the inability to use the product. Before using, users shall determine the suitability of the product for their intended use, and users assume all risk and liability whatsoever in connection therewith.

## Looking for pricing, stock, or lifecycle information?

Click below to explore more details on WIN SOURCE:

 [View 60601 on WIN SOURCE](#)

 [Desco Information](#)

## Optimize Your Supply Chain with WIN SOURCE Solutions

-  Global Sourcing Solution
-  Obsolete Management
-  Cost Control Management
-  Shortage Management
-  Alternative Solution
-  Excess Inventory Management