



**THE DATASHEET OF  
450-0148R**



## Integrated 802.11 b/g/n WLAN, Bluetooth & BLE Module

### FEATURES

- IEEE 802.11 b/g/n (single stream n)
- Typical WLAN Transmit Power:
  - +17.5 dBm, 11 Mbps, CCK (b)
  - +14.0 dBm, 54 Mbps, OFDM (g)
  - +12.5 dBm, HT20 MCS7 (n)
- Typical WLAN Sensitivity:
  - -88 dBm, 8% PER, 11 Mbps (b)
  - -75 dBm, 10% PER, 54 Mbps (g)
  - -72 dBm, 10% PER, MCS7 (n)
- Bluetooth v4.2 BR /DR/LE
- WLAN and Bluetooth coexistence
- Available in two footprint styles:
  - Easy to Integrate: 15.5 mm x 21 mm
  - Miniature footprint: 10 mm x 10 mm
- Available with integrated chip antenna or U.FL connector for external antenna
- Operating voltage: 3.0V to 3.6V
- Operating temperature: -40° to +85° C
- Storage temperature: -40° to +125° C
- Compact design based on Broadcom BCM4343W SoC
- Worldwide acceptance: FCC (USA), IC (Canada), ETSI (Europe), Giteki (Japan), and RCM (AU/NZ)  
BT SIG QDID: 85005
- REACH and RoHS compliant

### APPLICATIONS

- Security & Building Automation
- Internet of Things / M2M Connectivity
- Smart Gateways

### DESCRIPTION

The Sterling-LWB is a high performance 2.4 GHz WLAN and Bluetooth combo module based on latest-generation silicon (Broadcom's BCM4343W). With an industrial temperature rating, broad country certifications, and the availability of three different package styles, the Sterling-LWB provides significant flexibility to meet various end user application needs.

The on-module chip antenna package style for the Sterling-LWB eliminates complexity for design integration, simplifies manufacturing assembly with larger pin outs, and features an advanced chip antenna that offers greater resistance to de-tuning than typical trace or chip antennas.



The module includes the MAC, Baseband and Radio to support WLAN applications and an independent, high-speed UART is provided for the Bluetooth host interface. In addition, the latest Linux and Android drivers are supported directly by LSR and Broadcom.

Need to get to market quickly? Not an expert in 802.11. Need a custom antenna? Would you like to own the design? Would you like a custom design? Not quite sure what you need? Do you need help with your host board? LSR Design Services will be happy to develop custom hardware or software or assist with integrating the design. Contact us at [sales@lsr.com](mailto:sales@lsr.com) or call us at **262-375-4400**.

**TABLE OF CONTENTS**

<b>FEATURES .....</b>	<b>1</b>
<b>APPLICATIONS .....</b>	<b>1</b>
<b>DESCRIPTION .....</b>	<b>1</b>
<b>TABLE OF CONTENTS .....</b>	<b>2</b>
<b>MODULE VARIANTS .....</b>	<b>5</b>
<b>FUNCTIONAL FEATURES .....</b>	<b>8</b>
WLAN Features .....	8
Bluetooth Features .....	8
Wireless Security System Features .....	8
<b>ORDERING INFORMATION .....</b>	<b>9</b>
<b>MODULE ACCESSORIES.....</b>	<b>9</b>
<b>APPLICABLE DOCUMENTS .....</b>	<b>10</b>
<b>BLOCK DIAGRAMS.....</b>	<b>11</b>
<b>BASE SIP MODULE FOOTPRINT AND PIN DEFINITIONS .....</b>	<b>14</b>
<b>BASE SIP MODULE PIN DESCRIPTIONS .....</b>	<b>15</b>
<b>U.FL AND CHIP ANTENNA MODULE FOOTPRINT AND PIN DEFINITIONS.....</b>	<b>20</b>
<b>U.FL AND CHIP ANTENNA MODULE PIN DESCRIPTIONS.....</b>	<b>21</b>
<b>MODULE POWER STATES .....</b>	<b>23</b>
<b>U.FL AND CHIP ANTENNA MODULE PIN I/O STATES .....</b>	<b>24</b>
<b>GENERAL CHARACTERISTICS.....</b>	<b>27</b>
WLAN Power Consumption.....	29
Bluetooth Power Consumption.....	29
Power Supply Requirements.....	30
Calibration Current Profile .....	31
<b>CRYSTAL OSCILLATOR REQUIREMENTS .....</b>	<b>32</b>

The information in this document is subject to change without notice.

---

<b>CONTROL SIGNAL TIMING DIAGRAMS .....</b>	<b>33</b>
WLAN RF Characteristics .....	35
Bluetooth RF Characteristics .....	37
<b>WLAN HOST INTERFACE .....</b>	<b>38</b>
SDIO Interface .....	38
<b>BLUETOOTH UART HOST INTERFACE.....</b>	<b>40</b>
Overview .....	40
Soldering Recommendations .....	41
Recommended Reflow Profile for Lead Free Solder .....	41
<b>WIFI MAC IDS/BLUETOOTH MAC IDS .....</b>	<b>42</b>
<b>CLEANING .....</b>	<b>43</b>
<b>OPTICAL INSPECTION .....</b>	<b>43</b>
<b>REWORK .....</b>	<b>43</b>
<b>SHIPPING, HANDLING, AND STORAGE .....</b>	<b>43</b>
Shipping.....	43
Handling .....	43
Moisture Sensitivity Level (MSL) .....	43
Storage .....	43
Repeated Reflow Soldering.....	44
<b>AGENCY CERTIFICATIONS .....</b>	<b>45</b>
<b>AGENCY STATEMENTS.....</b>	<b>45</b>
Federal Communication Commission Interference Statement .....	45
Industry Canada Statements.....	46
<b>OEM RESPONSIBILITIES TO COMPLY WITH FCC AND INDUSTRY CANADA REGULATIONS.....</b>	<b>47</b>
<b>OEM LABELING REQUIREMENTS FOR END-PRODUCT .....</b>	<b>48</b>
<b>OEM END PRODUCT USER MANUAL STATEMENTS.....</b>	<b>49</b>
<b>EUROPE .....</b>	<b>50</b>
CE Notice .....	50
Declaration of Conformity (DOC) .....	50

---

The information in this document is subject to change without notice.

---

<b>AUSTRALIA .....</b>	<b>50</b>
RCM.....	50
<b>BLUETOOTH SIG QUALIFICATION .....</b>	<b>51</b>
Overview .....	51
Qualification Steps When Referencing a Laird Controller Subsystem Design .....	51
Additional Assistance.....	52
<b>BASE SIP MODULE MECHANICAL DATA.....</b>	<b>53</b>
<b>BASE SIP MODULE PCB FOOTPRINT .....</b>	<b>54</b>
<b>BASE SIP MODULE RECOMMENDED SOLDER STENCIL .....</b>	<b>55</b>
<b>BASE SIP MODULE TAPE AND REEL PACKAGING.....</b>	<b>56</b>
<b>U.FL AND CHIP ANTENNA MECHANICAL DATA.....</b>	<b>57</b>
<b>U.FL AND CHIP ANTENNA PCB FOOTPRINT .....</b>	<b>58</b>
<b>U.FL AND CHIP ANTENNA TAPE AND REEL PACKAGING .....</b>	<b>59</b>
<b>DEVICE MARKINGS.....</b>	<b>60</b>
SiP Module .....	60
Antenna Option Modules .....	62
<b>CONTACTING LSR .....</b>	<b>66</b>

## MODULE VARIANTS

The LSR Sterling-LWB Module is available in three different versions. Depending on the user's antenna and footprint needs, there is a variant to suite most application requirements. LSR recommends that for simplicity of both the host PCB design, as well as the manufacturing process, that either the Chip Antenna or RF Connector version of the modules be used in your design.

- **450-0159 - Base SiP Module**

This module variant is supplied in a compact, 151 pin, 0.5 mm pitch LGA footprint. Unlike the other module variants, it requires the addition of either an off module antenna or RF connector, as well as the associated matching components. In order to benefit from the EMC certifications on the module, strictly following the layout in the module application guide is required. This requires adherence to the PCB stack-up and layout around the antenna. The footprint of this module may require additional care during reflow and PCB assembly.

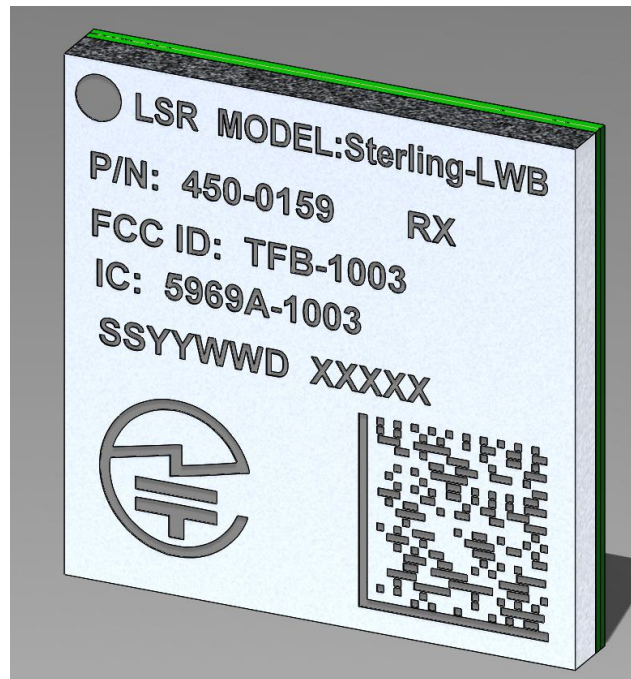

**Figure 1 Sterling-LWB Base SiP Module (450-0159)**

- **450-0148 – U.FL Module**

This module variant integrates the 450-0159 Base SiP Module, a U.FL RF connector, and all associated RF matching components on a PCB. This integrated approach not only provides a U.FL connector for connections to external antennas, but also simplifies and reduces the cost of the end users host board by simplifying the module PCB footprint.

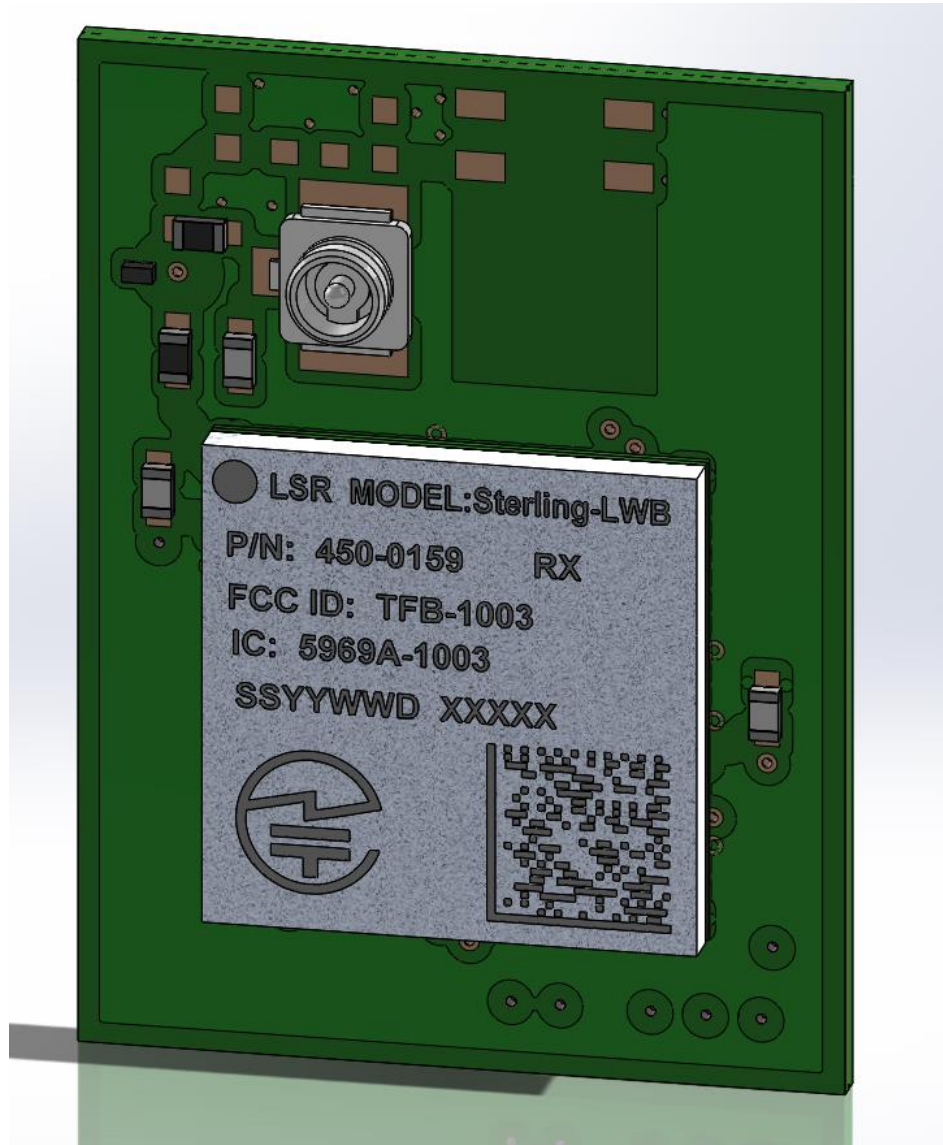

**Figure 2 Sterling-LWB U.FL Module (450-0148)**

- **450-0152 - Chip Antenna Module**

This module variant integrates the 450-0159 Base SiP Module, a chip antenna, and all associated RF matching components on a PCB. This integrated approach not only provides an external antenna solution, but also simplifies and reduces the cost of the end users host board by simplifying the module PCB footprint.



**Figure 3 Sterling-LWB Chip Antenna Module (450-0152)**

## FUNCTIONAL FEATURES

### WLAN Features

- IEEE 802.11b/g/n 1x1 2.4 GHz Radio
  - Internal Power Amplifier (PA)
  - Internal Low Noise Amplifier(LNA)
  - Internal T/R Switch
  - Simultaneous BT/WLAN reception with a single antenna.
- Media Access Controller (MAC)
- Physical Layer (PHY)
- Baseband Processor
- **Standards**
  - IEEE 802.11b, 802.11g, 802.11n (single stream)

### Bluetooth Features

- Class 2 power amplifier with Class 2 capability
- HCI Interface using High Speed UART
- PCM for Audio Data
- Bluetooth v4.2 BR /DR/LE

### Wireless Security System Features



- **Supported modes:**
  - Open (no security)
  - WEP
  - WPA Personal
  - WPA2 Personal
  - WMM
  - WMM-PS (U-APSD)
  - WMM-SA
  - WAPI
  - AES (Hardware Accelerator)
  - TKIP (host-computed)
  - CKIP (SW Support)

**ORDERING INFORMATION**



Order Number	Description
450-0148C	Sterling-LWB U.FL Module (Cut Tape)
450-0148R	Sterling-LWB U.FL Module (Tape and Reel, SPQ = 1000)
450-0152C	Sterling-LWB Chip Antenna Module (Cut Tape)
450-0152R	Sterling-LWB Chip Antenna Module (Tape and Reel, SPQ = 1000)
450-0159C	Sterling-LWB Base SiP Module (Cut Tape)
450-0159R	Sterling-LWB Base SiP Module (Tape and Reel, SPQ = 1000)
450-0155	Sterling-LWB SD Development Board, U.FL
450-0156	Sterling-LWB SD Development Board, Chip Antenna
450-0173	Sterling-LWB Development Board, WICED

**Table 1 Orderable Sterling-LWB Part Numbers**

**MODULE ACCESSORIES**

	Order Number	Description
	<b>001-0001</b>	2.4 GHz Dipole Antenna with Reverse Polarity SMA Connector
	<b>080-0001</b>	U.FL to Reverse Polarity SMA Bulkhead Cable 105mm

The information in this document is subject to change without notice.

	<p><b>001-0014</b></p>	<p>2.4 GHz FlexPIFA Antenna</p>
	<p><b>001-0015</b></p>	<p>2.4 GHz FlexNotch Antenna</p>
	<p><b>001-0030</b></p>	<p>2.4 GHz Metal FlexPIFA Antenna w/U.FL Cable, 100mm</p>

**Table 2 Module Accessories**

**APPLICABLE DOCUMENTS**

- Sterling-LWB Module User Guide (330-0192)
- Sterling-LWB SD Card User Guide (330-0245)
- Sterling-LWB i.MX6 UltraLite Eval Kit Linux Integration User Guide (330-0201)
- Sterling-LWB WICED Board User Guide (330-0234)

The information in this document is subject to change without notice.

**BLOCK DIAGRAMS**

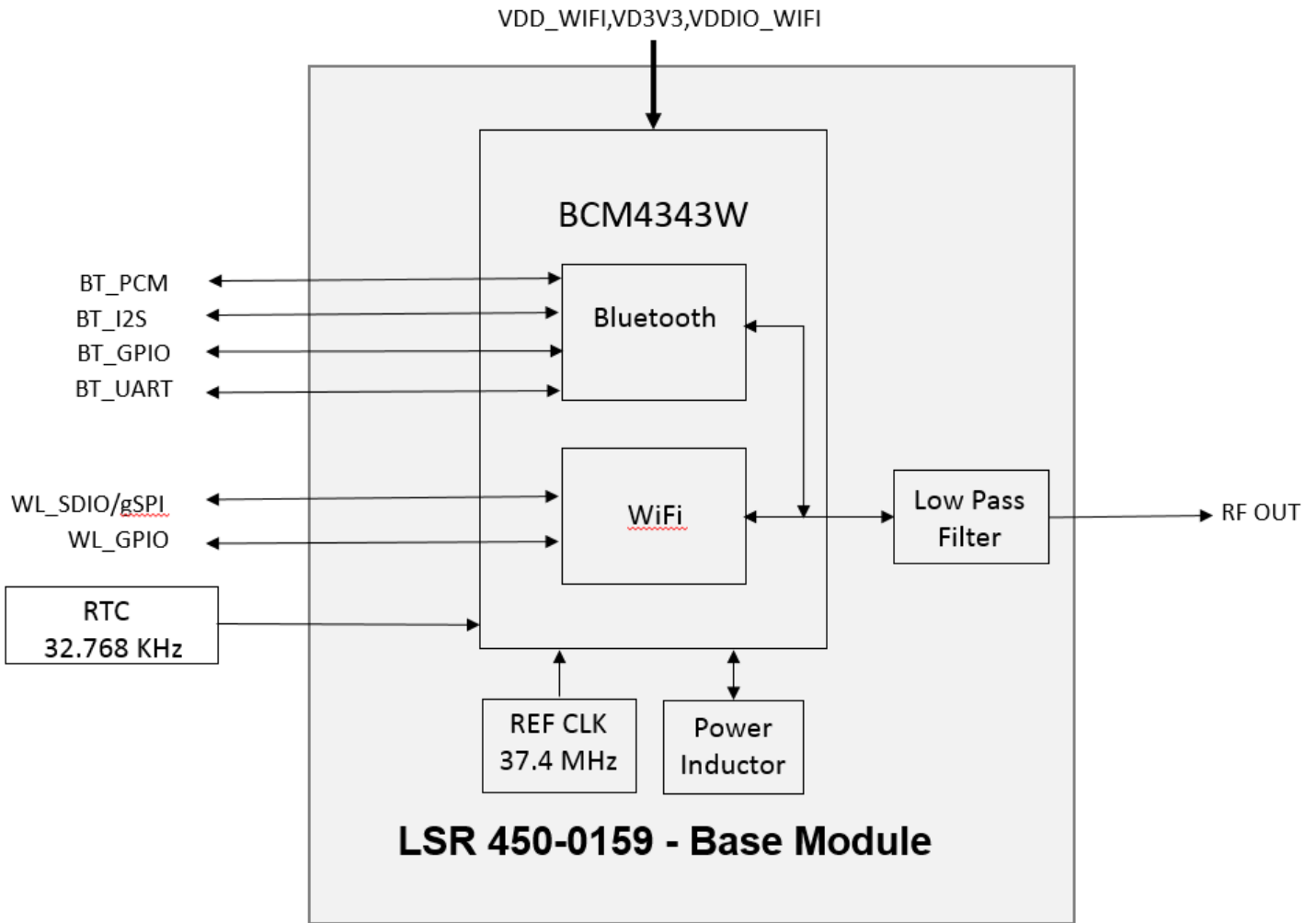

**Figure 4 Sterling-LWB Base SiP Module Block Diagram**

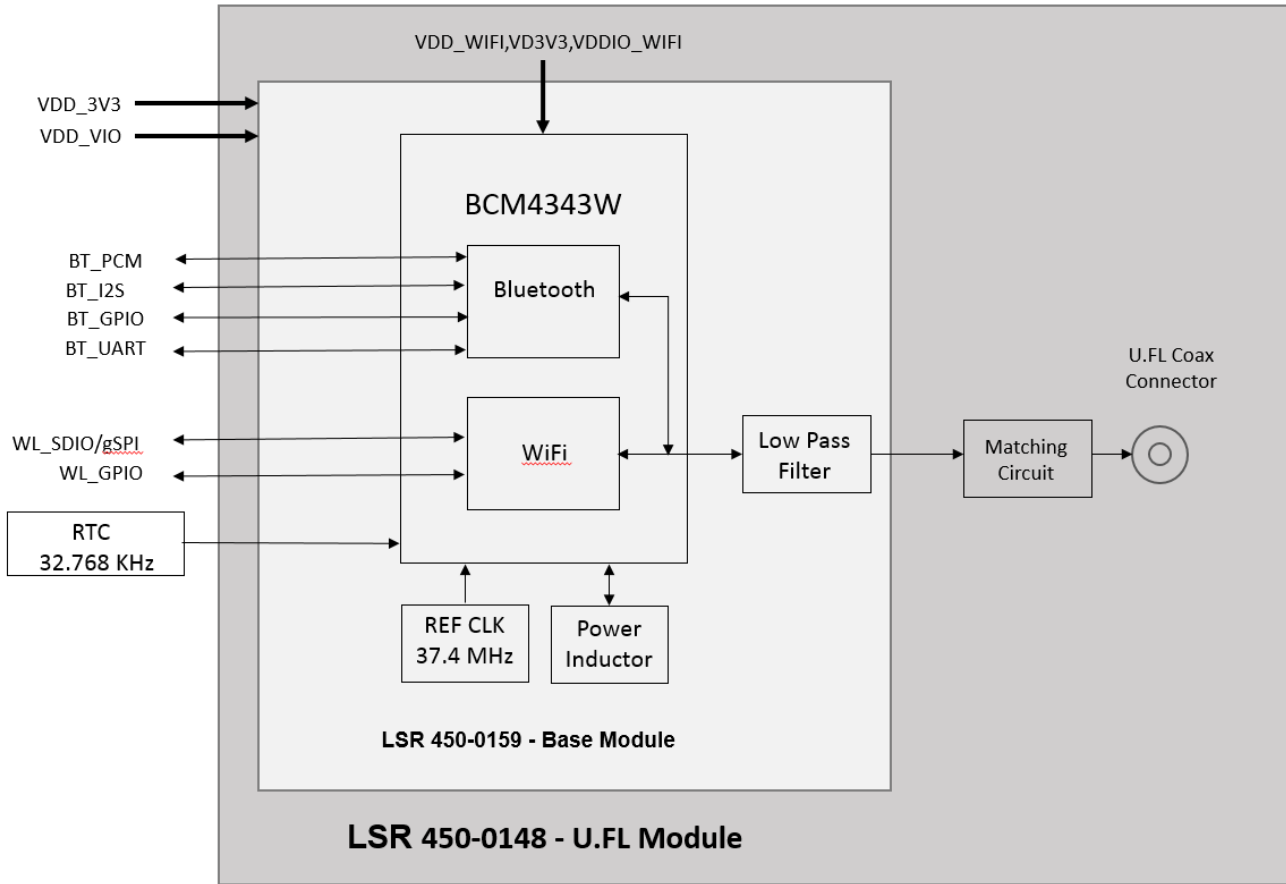
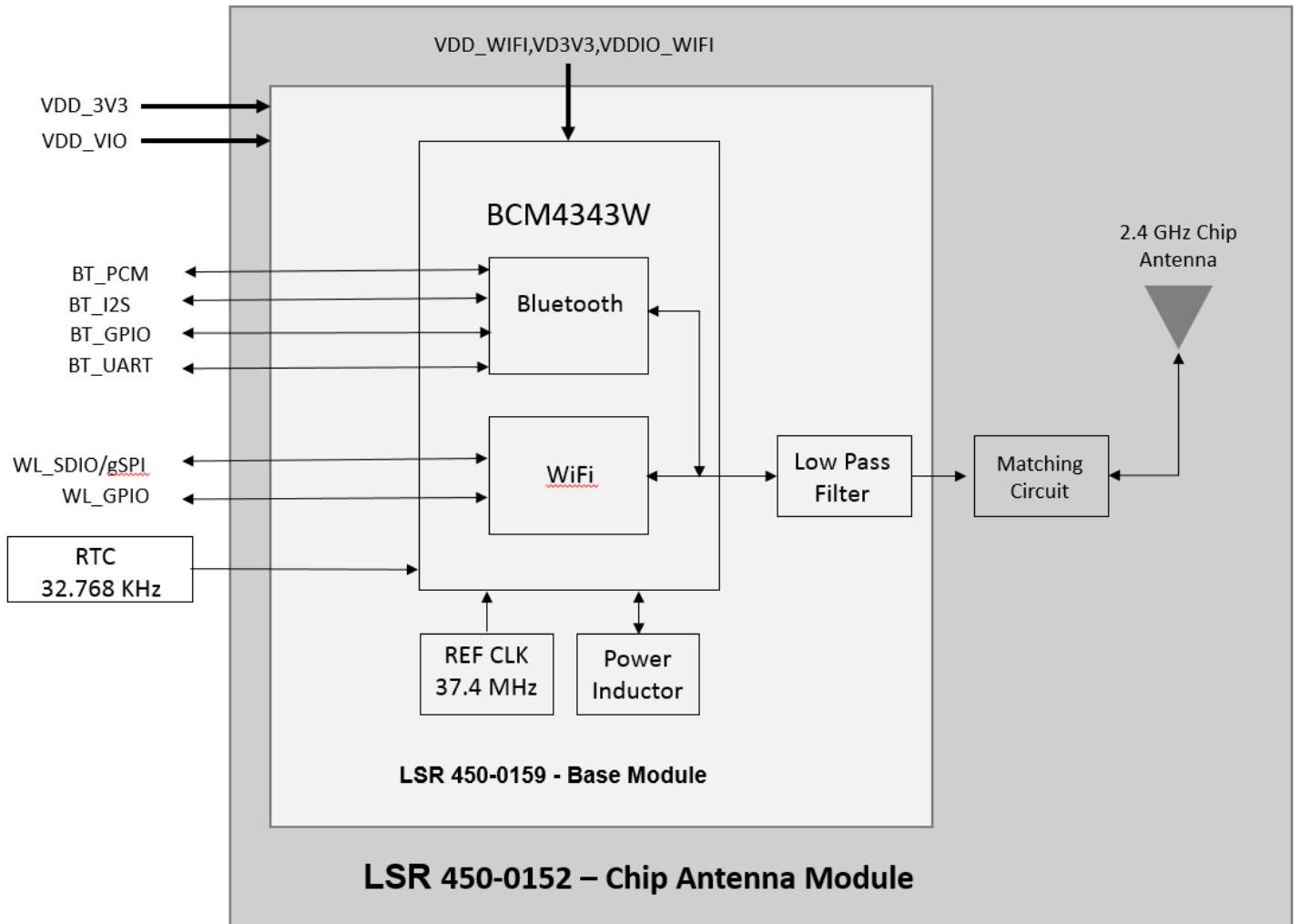

Figure 5 Sterling-LWB U.FL Module Block Diagram



**Figure 6 Sterling-LWB Chip Antenna Module Block Diagram**

**BASE SIP MODULE FOOTPRINT AND PIN DEFINITIONS**

Note that the following footprint and pin definition applies to the Sterling-LWB Base SiP Module (450-0159). There are two module footprints depending on which variant of the module is being used, so it is important to make certain you are using the correct version on your design.

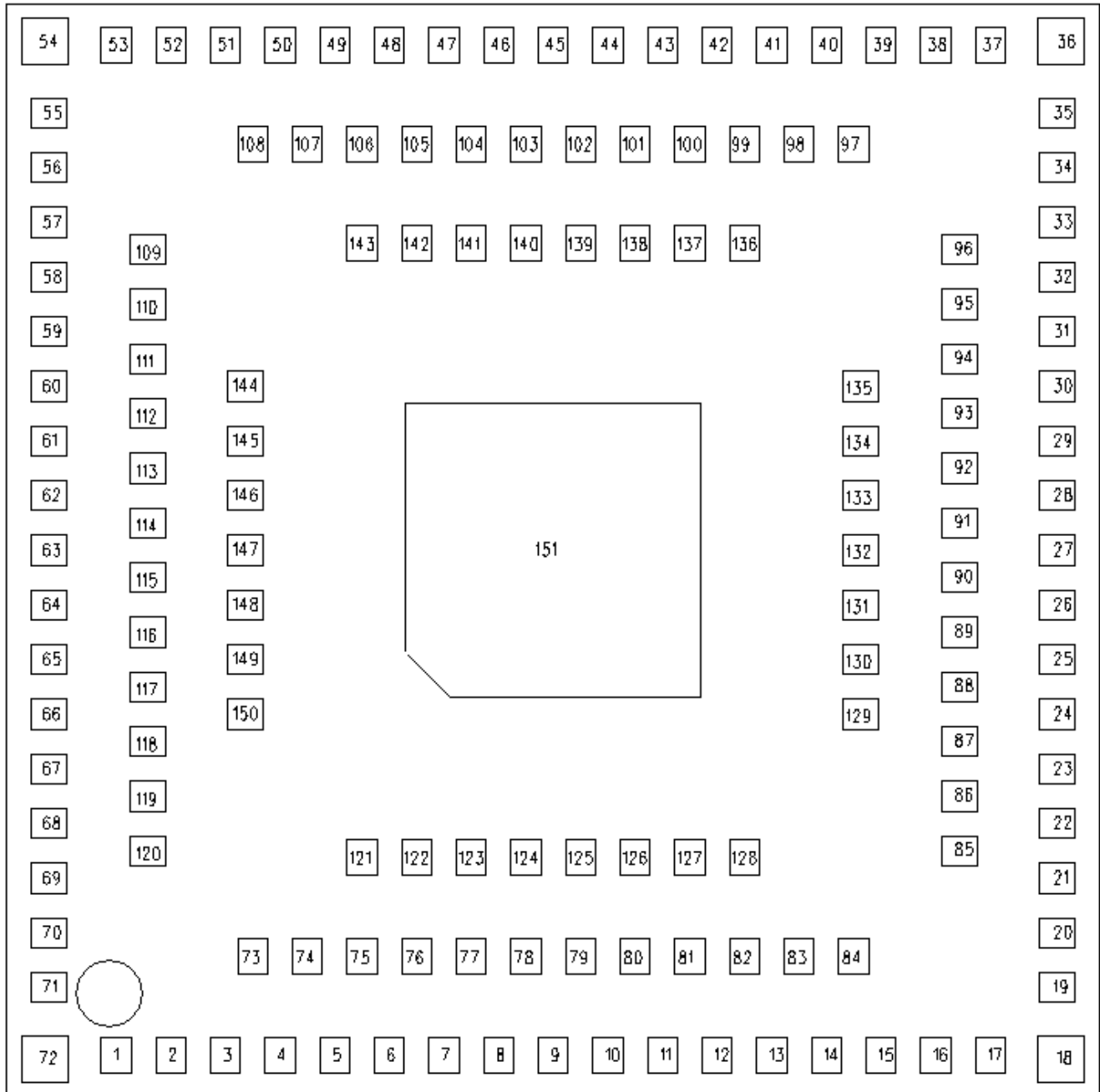

**Figure 7 Sterling-LWB Base SiP Module Pinout (Top View)**

**BASE SIP MODULE PIN DESCRIPTIONS**

Module Pin	Name	I/O Type	Description
1	ANT	RF	RF TRANSMITTER OUTPUT AND RECEIVE INPUT
2	GND	GND	GROUND
3	VDD_3V3_WIFI_PA	PI	WIFI PA POWER SUPPLY
4	VDD_3V3_WIFI_PA	PI	WIFI PA POWER SUPPLY
5	GND	GND	GROUND
6	NC	-	NO CONNECT (DO NOT CONNECT)
7	GND	GND	GROUND
8	NC	-	NO CONNECT (DO NOT CONNECT)
9	NC	-	NO CONNECT (DO NOT CONNECT)
10	GND	GND	GROUND
11	NC	-	NO CONNECT (DO NOT CONNECT)
12	NC	-	NO CONNECT (DO NOT CONNECT)
13	NC	-	NO CONNECT (DO NOT CONNECT)
14	NC	-	NO CONNECT (DO NOT CONNECT)
15	GND	GND	GROUND
16	NC	-	NO CONNECT (DO NOT CONNECT)
17	NC	-	NO CONNECT (DO NOT CONNECT)
18	GND	GND	GROUND
19	CLK_REQ	DO	EXTERNAL SYSTEM CLOCK REQUEST – USED WHEN THE SYSTEM CLOCK IS NOT PROVIDED BY A DEDICATED CRYSTAL
20	BT_GPIO_3	DIO	WPT_INTb TO WIRELESS CHARGING PMU
21	NC	-	NO CONNECT (DO NOT CONNECT)
22	NC	-	NO CONNECT (DO NOT CONNECT)
23	GND	GND	GROUND
24	NC	-	NO CONNECT (DO NOT CONNECT)
25	GND	GND	GROUND
26	32K_PWM_IN	DI	EXTERNAL SLEEP CLOCK INPUT
27	GND	GND	GROUND
28	VDD3V3_WiFi_IO	PI	DC SUPPLY FOR WIFI AND I/O
29	GND	GND	GROUND
30	NC	-	NO CONNECT (DO NOT CONNECT)

The information in this document is subject to change without notice.

Module Pin	Name	I/O Type	Description
31	NC	-	NO CONNECT (DO NOT CONNECT)
32	NC	-	NO CONNECT (DO NOT CONNECT)
33	NC	-	NO CONNECT (DO NOT CONNECT)
34	GND	GND	GROUND
35	NC	-	NO CONNECT (DO NOT CONNECT)
36	GND	GND	GROUND
37	NC	-	NO CONNECT (DO NOT CONNECT)
38	NC	-	NO CONNECT (DO NOT CONNECT)
39	GND	GND	GROUND
40	SDIO_D3	DIO	SDIO DATA LINE 3
41	GND	GND	GROUND
42	VDD3V3_WIFI	PI	WIFI POWER SUPPLY
43	VDD3V3_WIFI	PI	WIFI POWER SUPPLY
44	GND	GND	GROUND
45	NC	-	NO CONNECT (DO NOT CONNECT)
46	NC	-	NO CONNECT (DO NOT CONNECT)
47	GND	GND	GROUND
48	NC	-	NO CONNECT (DO NOT CONNECT)
49	GND	GND	GROUND
50	NC	-	NO CONNECT (DO NOT CONNECT)
51	GND	GND	GROUND
52	NC	-	NO CONNECT (DO NOT CONNECT)
53	NC	-	NO CONNECT (DO NOT CONNECT)
54	GND	GND	GROUND
55	BT_PCM_CLK	DIO	PCM CLOCK; CAN BE MASTER (OUTPUT) OR SLAVE (INPUT)
56	BT_DEV_WAKE	DIO	DEV_WAKE OR GENERAL-PURPOSE I/O SIGNAL
57	BT_HOST_WAKE	DO	HOST_WAKE OR GENERAL-PURPOSE I/O SIGNAL
58	GND	GND	GROUND
59	NC	-	NO CONNECT (DO NOT CONNECT)
60	GND	GND	GROUND
61	GND	GND	GROUND
62	NC	-	NO CONNECT (DO NOT CONNECT)

The information in this document is subject to change without notice.

Module Pin	Name	I/O Type	Description
63	NC	-	NO CONNECT (DO NOT CONNECT)
64	GND	GND	GROUND
65	NC	-	NO CONNECT (DO NOT CONNECT)
66	GND	GND	GROUND
67	NC	-	NO CONNECT (DO NOT CONNECT)
68	NC	-	NO CONNECT (DO NOT CONNECT)
69	NC	-	NO CONNECT (DO NOT CONNECT)
70	GND	GND	GROUND
71	GND	GND	GROUND
72	GND	GND	GROUND
73	GND	GND	GROUND
74	NC	-	NO CONNECT (DO NOT CONNECT)
75	NC	-	NO CONNECT (DO NOT CONNECT)
76	NC	-	NO CONNECT (DO NOT CONNECT)
77	GND	GND	GROUND
78	NC	-	NO CONNECT (DO NOT CONNECT)
79	NC	-	NO CONNECT (DO NOT CONNECT)
80	NC	-	NO CONNECT (DO NOT CONNECT)
81	NC	-	NO CONNECT (DO NOT CONNECT)
82	NC	-	NO CONNECT (DO NOT CONNECT)
83	NC	-	NO CONNECT (DO NOT CONNECT)
84	NC	-	NO CONNECT (DO NOT CONNECT)
85	NC	-	NO CONNECT (DO NOT CONNECT)
86	NC	-	NO CONNECT (DO NOT CONNECT)
87	NC	-	NO CONNECT (DO NOT CONNECT)
88	WL_REG_ON	DI	USED BY PMU TO POWER UP OR POWER DOWN THE INTERNAL REGULATORS USED BY THE WLAN SECTION
89	WIFI_GPIO_1	DIO	PROGRAMMABLE GPIO PIN
90	NC	-	NO CONNECT (DO NOT CONNECT)
91	GND	GND	GROUND
92	NC	-	NO CONNECT (DO NOT CONNECT)
93	NC	-	NO CONNECT (DO NOT CONNECT)

The information in this document is subject to change without notice.

Module Pin	Name	I/O Type	Description
94	GND	GND	GROUND
95	SDIO_D0	DIO	SDIO DATA LINE 0
96	SDIO_D1	DIO	SDIO DATA LINE 1
97	SDIO_D2	DIO	SDIO DATA LINE 2
98	SDIO_CMD	DIO	SDIO COMMAND LINE
99	GND	GND	GROUND
100	SDIO_CLK	DI	SDIO CLOCK INPUT
101	GND	GND	GROUND
102	NC	-	NO CONNECT (DO NOT CONNECT)
103	NC	-	NO CONNECT (DO NOT CONNECT)
104	NC	-	NO CONNECT (DO NOT CONNECT)
105	BT_I2S_CLK	DIO	I2S CLOCK; CAN BE MASTER (OUTPUT) OR SLAVE (INPUT)
106	NC	-	NO CONNECT (DO NOT CONNECT)
107	NC	-	NO CONNECT (DO NOT CONNECT)
108	NC	-	NO CONNECT (DO NOT CONNECT)
109	BT_I2S_WS	DIO	I2S_WS; CAN BE MASTER (OUTPUT) OR SLAVE (INPUT)
110	BT_I2S_D0	DIO	I2S DATA OUTPUT
111	NC	-	NO CONNECT (DO NOT CONNECT)
112	GND	GND	GROUND
113	GND	GND	GROUND
114	GND	GND	GROUND
115	GND	GND	GROUND
116	GND	GND	GROUND
117	NC	-	NO CONNECT (DO NOT CONNECT)
118	NC	-	NO CONNECT (DO NOT CONNECT)
119	NC	-	NO CONNECT (DO NOT CONNECT)
120	GND	GND	GROUND
121	NC	-	NO CONNECT (DO NOT CONNECT)
122	NC	-	NO CONNECT (DO NOT CONNECT)
123	GND	GND	GROUND
124	WIFI_GPIO_4	DIO	PROGRAMMABLE GPIO PIN
125	NC	-	NO CONNECT (DO NOT CONNECT)

The information in this document is subject to change without notice.

Module Pin	Name	I/O Type	Description
126	WIFI_GPIO_2	DIO	PROGRAMMABLE GPIO PIN
127	WIFI_GPIO_3	DIO	PROGRAMMABLE GPIO PIN
128	NC	-	NO CONNECT (DO NOT CONNECT)
129	BT_GPIO_4	DIO	BSC_SDA TO/FROM WIRELESS CHARGING PMU.
130	BT_GPIO_5	DIO	BSC_SCL FROM WIRELESS CHARGING PMU.
131	WIFI_GPIO_0	DIO	PROGRAMMABLE GPIO PIN. THIS PIN BECOMES AN OUTPUT PIN WHEN IT IS USED AS WLAN_HOST_WAKE/ OUT-OF-BAND SIGNAL.
132	GND	GND	GROUND
133	NC	-	NO CONNECT (DO NOT CONNECT)
134	GND	GND	GROUND
135	GND	GND	GROUND
136	BT_REG_ON	DI	USED BY PMU TO POWER UP OR POWER DOWN THE INTERNAL REGULATORS USED BY THE BLUETOOTH SECTION
137	NC	-	NO CONNECT (DO NOT CONNECT)
138	BT_UART_RTS_L	DO	UART REQUEST-TO-SEND
139	BT_UART_CTS_L	DI	UART CLEAR-TO-SEND
140	BT_UART_TXD	DO	UART TRANSMIT OUTPUT
141	BT_UART_RXD	DI	UART RECEIVE INPUT
142	NC	-	NO CONNECT (DO NOT CONNECT)
143	NC	-	NO CONNECT (DO NOT CONNECT)
144	BT_PCM_SYNC	DIO	PCM SYNC; CAN BE MASTER (OUTPUT) OR SLAVE (INPUT)
145	BT_PCM_OUT	DO	PCM DATA OUTPUT
146	BT_PCM_IN	DI	PCM DATA INPUT SENSING
147	NC	-	NO CONNECT (DO NOT CONNECT)
148	GND	GND	GROUND
149	GND	GND	GROUND
150	NC	-	NO CONNECT (DO NOT CONNECT)
151	GND	GND	GROUND

PI = Power Input, DI = Digital Input, DO = Digital Output, DIO = Bi-directional Digital Port, RF = Bi-directional RF Port, GND = Ground

**Table 3 Sterling-LWB Module Pin Descriptions**

The information in this document is subject to change without notice.



**U.FL AND CHIP ANTENNA MODULE PIN DESCRIPTIONS**

Module Pin	Name	I/O Type	Description
1	GND	GND	GROUND
2	BT_PCM_SYNC	DIO	PCM SYNC; CAN BE MASTER (OUTPUT) OR SLAVE (INPUT)
3	BT_PCM_IN	DI	PCM DATA INPUT SENSING
4	BT_PCM_OUT	DO	PCM DATA OUTPUT
5	VDD_3V3	PI	WIFI AND BLUETOOTH POWER SUPPLY
6	GND	GND	GROUND
7	WIFI_GPIO_4	DIO	PROGRAMMABLE GPIO PIN
8	WIFI_GPIO_3	DIO	PROGRAMMABLE GPIO PIN
9	WIFI_GPIO_2	DIO	PROGRAMMABLE GPIO PIN
10	WIFI_GPIO_1	DIO	PROGRAMMABLE GPIO PIN
11	WIFI_GPIO_0	DIO	PROGRAMMABLE GPIO PIN. THIS PIN BECOMES AN OUTPUT WHEN IT IS USED AS WLAN_HOST_WAKE/ OUT-OF-BAND SIGNAL.
12	WL_REG_ON	DI	USED BY PMU TO POWER UP OR POWER DOWN THE INTERNAL REGULATORS USED BY THE WLAN SECTION.
13	CLK_REQ	DO	EXTERNAL SYSTEM CLOCK REQUEST – USED WHEN THE SYSTEM CLOCK IS NOT PROVIDED BY A DEDICATED CRYSTAL
14	GND	GND	GROUND
15	BT_GPIO_3	DIO	PROGRAMMABLE GPIO PIN
16	BT_GPIO_4	DIO	PROGRAMMABLE GPIO PIN
17	BT_GPIO_5	DIO	PROGRAMMABLE GPIO PIN
18	GND	GND	GROUND
19	32KHZ_OSC_IN	DI	EXTERNAL SLEEP CLOCK INPUT
20	VDD_VIO	PI	DC SUPPLY FOR I/O
21	BT_REG_ON	DI	USED BY PMU TO POWER UP OR POWER DOWN THE INTERNAL REGULATORS USED BY THE BLUETOOTH SECTION.
22	SDIO_D0	DIO	SDIO DATA LINE 0
23	SDIO_D1	DIO	SDIO DATA LINE 1
24	GND	GND	GROUND
25	SDIO_D2	DIO	SDIO DATA LINE 2
26	SDIO_CMD	DIO	SDIO COMMAND LINE
27	SDIO_D3	DIO	SDIO DATA LINE 3

The information in this document is subject to change without notice.

Module Pin	Name	I/O Type	Description
28	GND	GND	GROUND
29	SDIO_CLK	DIO	SDIO CLOCK LINE
30	GND	GND	GROUND
31	BT_UART_RTS_L	DO	BT UART REQUEST-TO-SEND
32	BT_UART_CTS_L	DI	BT UART CLEAR-TO-SEND
33	BT_UART_TXD	DO	BT UART TRANSMIT OUTPUT
34	BT_UART_RXD	DI	BT UART RECEIVE INPUT
35	BT_I2S_CLK	DIO	I2S CLOCK; CAN BE MASTER (OUTPUT) OR SLAVE (INPUT)
36	BT_I2S_D0	DO	I2S DATA OUTPUT
37	BT_I2S_WS	DIO	I2S_WS; CAN BE MASTER (OUTPUT) OR SLAVE (INPUT)
38	BT_PCM_CLK	DIO	PCM CLOCK; CAN BE MASTER (OUTPUT) OR SLAVE (INPUT)
39	BT_DEV_WAKE	DIO	DEV_WAKE OR GENERAL-PURPOSE I/O SIGNAL
40	BT_HOST_WAKE	DO	HOST_WAKE OR GENERAL-PURPOSE I/O SIGNAL
41	GND	GND	GROUND
42	GND	GND	GROUND
43	GND	GND	GROUND
44	GND	GND	GROUND
45	GND	GND	GROUND
46	GND	GND	GROUND
47	GND	GND	GROUND

PI = Power Input, DI = Digital Input, DO = Digital Output, DIO = Bi-directional Digital Port, GND = Ground

**Table 4 Sterling-LWB U.FL and Chip Antenna Module Pin Descriptions**

## MODULE POWER STATES

The Sterling-LWB WLAN power states are described as follows:

- **Active mode**- All WLAN blocks in the Sterling-LWB are powered up and fully functional with active carrier sensing and frame transmission and receiving. All required regulators are enabled and put in the most efficient mode based on the load current. Clock speeds are dynamically adjusted by the PMU sequencer.
- **Doze mode**- The radio, analog domains, and most of the linear regulators are powered down. The rest of the BCM4343W remains powered up in an IDLE state. All main clocks (PLL, crystal oscillator) are shut down to reduce active power to the minimum. The 32.768 kHz LPO clock is available only for the PMU sequencer. This condition is necessary to allow the PMU sequencer to wake up the chip and transition to Active mode. In Doze mode, the primary power consumed is due to leakage current.
- **Deep-sleep mode**- Most of the chip, including analog and digital domains, and most of the regulators are powered off. Logic states in the digital core are saved and preserved to retention memory in the always-on domain before the digital core is powered off. To avoid lengthy hardware re-initialization, the logic states in the digital core are restored to their pre-deep-sleep settings when a wake-up event is triggered by an external interrupt, a host resume through the SDIO bus, or by the PMU timers.
- **Power-down mode**—The BCM4343W is effectively powered off by shutting down all internal regulators. The chip is brought out of this mode by external logic re-enabling the internal regulators.

**U.FL AND CHIP ANTENNA MODULE PIN I/O STATES**

Pin #	Name	Keeper (b)	Active Mode	Low Power State/Sleep (All Power Present)	Power Down(c) WL_REG_ON=0 BT_REG_ON=0	Out of Reset: (VDD_VIO is present)		
						WL_REG_ON=1 BT_REG_ON=any	WL_REG_ON=1 BT_REG_ON=0	WL_REG_ON=0 BT_REG_ON=1
2	BT_PCM_SYNC	Y	Input No Pull(d)	Input No Pull(d)	High –Z No Pull	-	Input,PD	Input,PD
3	BT_PCM_IN	Y	Input No Pull(d)	Input No Pull(d)	High –Z No Pull	-	Input,PD	Input,PD
4	BT_PCM_OUT	Y	Input No Pull(d)	Input No Pull(d)	High –Z No Pull	-	Input,PD	Input,PD
7	WIFI_GPIO_4	Y	TBD	Active Mode	High –Z No Pull(f)	Input,GCI GPIO[1] PU	Active Mode	Input,PU
8	WIFI_GPIO_3	Y	TBD	Active Mode	High –Z No Pull(f)	Input,GCI GPIO[0] PU	Active Mode	Input,PU
9	WIFI_GPIO_2	Y	TBD	Active Mode	High –Z No Pull(f)	Input,GCI GPIO[7] NoPull	Active Mode	Input, Strap, NoPull
10	WIFI_GPIO_1	Y	TBD	Active Mode	High –Z No Pull(f)	Input,PD	Active Mode	Input, Strap, PD
11	WIFI_GPIO_0	Y	TBD	Active Mode	High –Z No Pull(f)	Input,SDIO OOB Int. NoPull	Active Mode	Input,NoPull
12	WL_REG_ON	N	Input; PD (pull-down can be disabled)	Input; PD (pull-down can be disabled)	Input; PD (of 200K)	Input; PD (200K)	Input; PD (200K)	-
13	CLK_REQ	Y	Open drain or push-pull (Active high)	Open drain or push-pull (Active high)	PD	Open drain, (Active high)	Open drain, (Active high)	Open drain, (Active high)
21	BT_REG_ON	N	Input; PD (pull-down can be disabled)	Input; PD (pull-down can be disabled)	Input; PD (of 200K)	Input; PD (200K)	Input; PD (200K)	Input; PD (200K)
22	SDIO_D0	N	SDIO MODE -> NoPull	SDIO MODE -> NoPull	SDIO MODE -> NoPull	SDIO MODE ->PullUP	SDIO MODE -> NoPull	Input,PU
23	SDIO_D1	N	SDIO MODE -> NoPull	SDIO MODE -> NoPull	SDIO MODE -> NoPull	SDIO MODE ->PullUP	SDIO MODE -> NoPull	Input,PU

The information in this document is subject to change without notice.

Pin #	Name	Keeper (b)	Active Mode	Low Power State/Sleep (All Power Present)	Power Down(c) WL_REG_ON = 0 BT_REG_ON = 0	Out of Reset: (VDD_VIO is present)		
						WL_REG_ON = 1 BT_REG_ON = any	WL_REG_ON = 1 BT_REG_ON = 0	WL_REG_ON = 0 BT_REG_ON = 1
25	SDIO_D2	N	SDIO MODE -> NoPull	SDIO MODE -> NoPull	SDIO MODE -> NoPull	SDIO MODE -> PullUP	SDIO MODE -> NoPull	Input, PU
26	SDIO_CMD	N	SDIO MODE -> NoPull	SDIO MODE -> NoPull	SDIO MODE -> NoPull	SDIO MODE -> PullUP	SDIO MODE -> NoPull	Input, PU
27	SDIO_D3	N	SDIO MODE -> NoPull	SDIO MODE -> NoPull	SDIO MODE -> NoPull	SDIO MODE -> PullUP	SDIO MODE -> NoPull	Input, PU
29	SDIO_CLK	N	SDIO MODE -> NoPull	SDIO MODE -> NoPull	SDIO MODE -> NoPull	SDIO MODE -> NoPull	SDIO MODE -> NoPull	Input
31	BT_UART_RTS_L	Y	Output: NoPull	Output: NoPull	High-Z, NoPull	-	Input: PU	Output: NoPull
32	BT_UART_CTS_L	Y	Input: NoPull	Input: NoPull	High-Z, NoPull	-	Input: PU	Input: NoPull
33	BT_UART_TXD	Y	Output: NoPull	Output: NoPull	High-Z, NoPull	-	Input: PU	Output: NoPull
34	BT_UART_RXD	Y	Input: PU	Input: NoPull	High-Z, NoPull	-	Input: PU	Input: NoPull
35	BT_I2S_CLK	Y	Input: NoPull(e)	Input: NoPull(e)	High-Z, NoPull	-	Input, PD	Output: Drive Low
36	BT_I2S_D0	Y	Input: NoPull(e)	Input: NoPull(e)	High-Z, NoPull	-	Input, PD	Input, PD
37	BT_I2S_WS	Y	Input: NoPull(e)	Input: NoPull(e)	High-Z, NoPull	-	Input, PD	Input, PD
38	BT_PCM_CLK	Y	Input No Pull(d)	Input No Pull(d)	High -Z NoPull	-	Input, PD	Input, PD
39	BT_DEV_WAKE	Y	I/O: PU, PD, NoPull (Programmable)	I/O: PU, PD, NoPull (Programmable)	High-Z, NoPull	-	Input, PD	Input, PD
40	BT_HOST_WAKE	Y	I/O: PU, PD, NoPull (Programmable)	I/O: PU, PD, NoPull (Programmable)	High-Z, NoPull	-	Input, PD	Ouput, Drive Low

**Table 5 I/O States**

The information in this document is subject to change without notice.

The following notations are used:

- I: Input signal
- O: Output signal
- I/O: Input/Output signal
- PU = Pulled up
- PD = Pulled down
- NoPull = Neither pulled up nor pulled down

**Notes:**

- PU = pulled up, PD = pulled down.
- N = pad has no keeper. Y = pad has a keeper. Keeper is always active except in the power-down state. If there is no keeper, and it is an input and there is NoPull, then the pad should be driven to prevent leakage due to floating pad, for example, SDIO\_CLK.
- In the Power-down state ( $xx\_REG\_ON = 0$ ): High-Z; NoPull => The pad is disabled because power is not supplied.
- Depending on whether the PCM interface is enabled and the configuration is master or slave mode, it can be either an output or input.
- Depending on whether the I2S interface is enabled, and configuration is master or slave mode, it can be either an input or output.
- The GPIO pull states for the active and low-power states are hardware defaults. They can all be subsequently programmed as a pull-up or pull-down.
- Strap state enables Serial Wire Debugging.

## GENERAL CHARACTERISTICS

### General

Characteristic	Description
Model Name	Sterling-LWB
Product Description	WiFi and Bluetooth Wireless Module
Dimension (SiP Module)	10 mm x 10 mm x 1.2 mm (W*L*T)
Dimension (Antenna Option Module)	15.5 mm x 21 mm x 2 mm (W*L*T)
Operating temperature	-40°C to 85°C
Storage temperature	-40°C to 125°C
Weight	0.9 g ± 0.1g

**Table 6 General Characteristics**

### DC Characteristics – General Purpose I/O

Parameter	Test Conditions	Min	Typical	Max	Unit
Logic input low, V <sub>IL</sub>	VDD_VIO = 1.8V	-	-	0.35x VDD_VIO	V
Logic input high, V <sub>IH</sub>	VDD_VIO = 1.8V	0.65x VDD_VIO	-	-	V
Logic output low, V <sub>OL</sub>	VDD_VIO = 1.8V 2mA	-	-	0.45	V
Logic output high, V <sub>OH</sub>	VDD_VIO = 1.8V 2mA	VDD_VIO-0.45	-	-	V
Logic input low, V <sub>IL</sub>	VDD_VIO = 3.3V	--	-	0.80	V
Logic input high, V <sub>IH</sub>	VDD_VIO = 3.3V	2.00	-	-	V
Logic output low, V <sub>OL</sub>	VDD_VIO = 3.3 2mA	-	-	0.40	V
Logic output high, V <sub>OH</sub>	VDD_VIO = 3.3 2mA	VDD_VIO-0.40	-	-	V

**Table 7 DC Characteristics General Purpose I/O**

**DC Characteristics – SDO Interface Pins**

Parameter	Test Conditions	Min	Typical	Max	Unit
Logic input low, $V_{IL}$	$VDD\_VIO = 1.8V$	-	-	0.58	V
Logic input high, $V_{IH}$	$VDD\_VIO = 1.8V$	1.27	-	-	V
Logic output low, $V_{OL}$	$VDD\_VIO = 1.8V$ 2mA	-	-	0.45	V
Logic output high, $V_{OH}$	$VDD\_VIO = 1.8V$ 2mA	1.4	-	-	V
Logic input low, $V_{IL}$	$VDD\_VIO = 3.3V$	$0.625 \times VDD\_VIO$	-	-	V
Logic input high, $V_{IH}$	$VDD\_VIO = 3.3V$	-	-	$0.25 \times VDD\_VIO$	V
Logic output low, $V_{OL}$	$VDD\_VIO = 3.3 @ 2mA$	-	-	$0.125 \times VDD\_VIO$	V
Logic output high, $V_{OH}$	$VDD\_VIO = 3.3 @ 2mA$	$0.75 \times VDD\_VIO$	-	-	V

**Figure 9 DC Characteristics SDIO I/O**

**RF Characteristics**

Parameter	Min	Typical	Max	Unit
RF frequency range	2400		2500	MHz
RF data rate	1	802.11 b/g/n rates supported	65	Mbps

**Table 8 RF Characteristics**

**WLAN Power Consumption**

Parameter	Test Conditions	Min	Typical	Max	Unit
Power Down Mode	T <sub>amb</sub> = +25°C, VDD3V3 = VDD_VIO = 3.3V	-	4	-	uA
Sleep (idle, unassociated)	T <sub>amb</sub> = +25°C, VDD3V3 = VDD_VIO = 3.3V	-	80	-	uA
IEEE Power Save DTIM 1	T <sub>amb</sub> = +25°C, VDD3V3 = VDD_VIO = 3.3V	-	2	-	mA
11b TX Current	11 Mbps, T <sub>amb</sub> = +25°C, 3.3V	-	290	-	mA
11g TX Current	6 Mbps, T <sub>amb</sub> = +25°C, 3.3V	-	245	-	mA
11g TX Current	54 Mbps, T <sub>amb</sub> = +25°C, 3.3V	-	215	-	mA
11n TX Current	MCS0, T <sub>amb</sub> = +25°C, 3.3V	-	230	-	mA
11n TX Current	MCS7, T <sub>amb</sub> = +25°C, 3.3V	-	200	-	mA
11b RX Current	11 Mbps, T <sub>amb</sub> = +25°C, 3.3V	-	35	-	mA
11g RX Current	54 Mbps, T <sub>amb</sub> = +25°C, 3.3V	-	35	-	mA
11n RX Current	MCS7, T <sub>amb</sub> = +25°C, 3.3V	-	35	-	mA

**Table 9 WLAN Power Consumption**

**Bluetooth Power Consumption**

Parameter	Test Conditions	Min	Typical	Max	Unit
Power Down Mode	T <sub>amb</sub> = +25°C, VDD3V3 = VDD_VIO = 3.3V	-	4	-	uA
GFSK TX Current	Constant Transmit, DH5, PRBS9 T <sub>amb</sub> = +25°C, 3.3V	-	50	-	mA
EDR TX Current	Constant Transmit, 2DH5,3DH5, PRBS9 T <sub>amb</sub> = +25°C, 3.3V	-	43	-	mA
GFSK RX Current	Constant Receive, DH5 T <sub>amb</sub> = +25°C, 3.3V	-	25	-	mA
EDR RX Current	Constant Receive, 2DH5, 3DH5 T <sub>amb</sub> = +25°C, 3.3V	-	25	-	mA
BLE TX Current	T <sub>amb</sub> = +25°C, 3.3V	-	44	-	mA
BLE RX Current	T <sub>amb</sub> = +25°C, 3.3V	-	25	-	mA

**Table 10 WLAN Power Consumption**

The information in this document is subject to change without notice.

**Power Supply Requirements**

Power Supply Requirements	Min	Typical	Max	Unit
VDD_VIO	1.8	3.3	3.6	V
VDD_VIO Current	-	300	-	uA
VDD_3V3	3.0	3.3	3.6	V
VDD_3V3 Current	-	See Note*	-	mA

**Table 11 Power Supply Requirements**

\* Note: See WLAN and Bluetooth Power Consumption Table for various steady-state operating values. This value is the typical peak current required for the Radio Transmitter Calibration Mode. See Current Waveform in Calibration Current Profile shown below.

**Calibration Current Profile**

Although the Max continuous supply current to the module is <300 mA, when providing power to the module, a power source capable of supplying 600 mA peak current for a duration of ~20 mSec is required by the module transmitter during calibration.

Module calibration occurs:

- (1) When the Module is initially powered up.
- (2) The module is reset.
- (3) When the radio is initialized.
- (4) Every 2 minutes after the radio is initialized.

Note: Radio calibration will not occur while the module is in modes Doze, Deep Sleep, Power Down or if the radio is not initialized.

**Figure 10** shows the current profile of the Sterling-LWB module during calibration. If current is limited to <600mA during this process, the module will fail to calibrate.

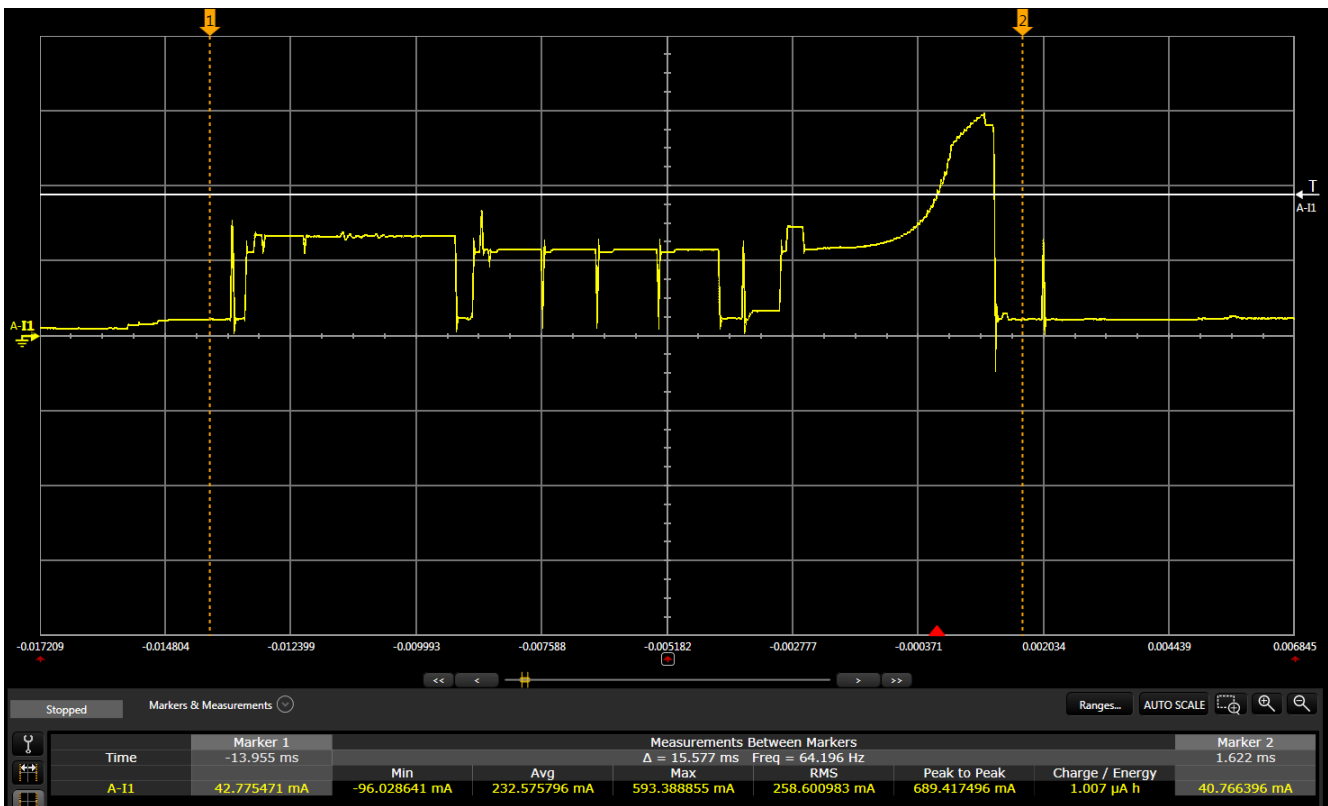

**Figure 10 Module RF Calibration Current Profile**

The information in this document is subject to change without notice.

**CRYSTAL OSCILLATOR REQUIREMENTS**

32.768 KHz Oscillator	
<b>Frequency Accuracy</b>	± 200 ppm
<b>Duty Cycle</b>	30% - 70%
<b>Input Signal Amplitude</b>	200 – 3300 mV, p-p
<b>Signal Type</b>	Square or Sine Wave
<b>Clock Jitter</b>	<10,000 ppm

**Table 12 Oscillator Requirements**

**Note:** A 32.768 KHz crystal is required in order for the module to be fully functional. The module will not boot without it.

**CONTROL SIGNAL TIMING DIAGRAMS**

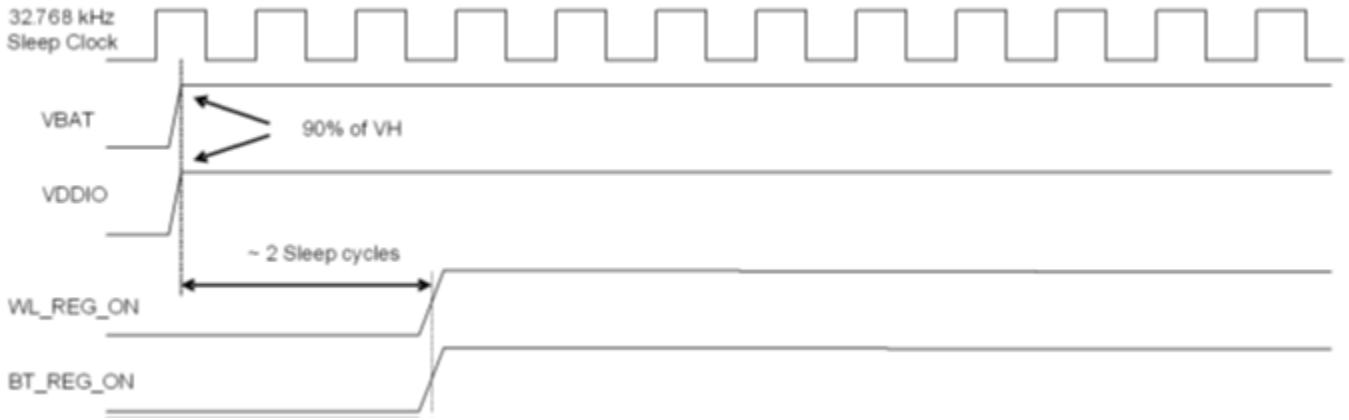

**Figure 11 WLAN = ON, Bluetooth = ON**

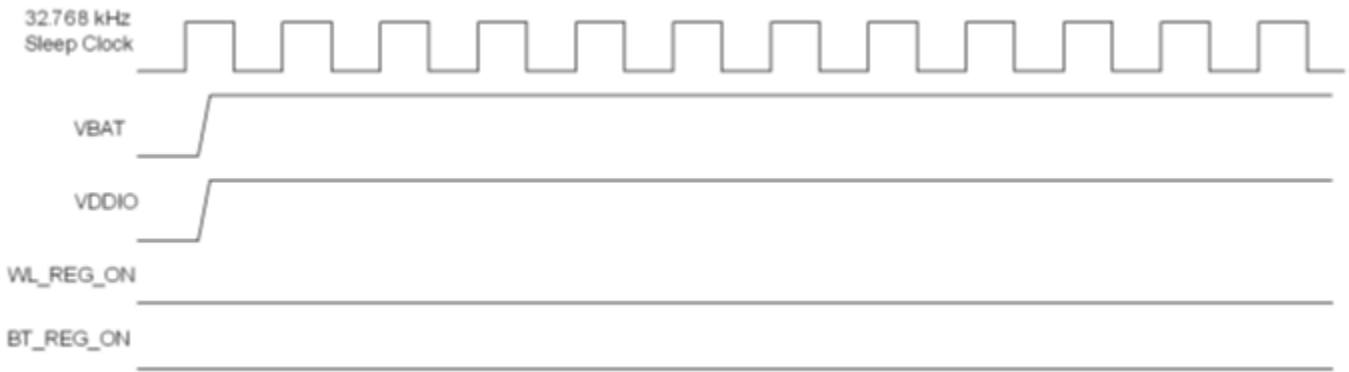

**Figure 12 WLAN = OFF, Bluetooth = OFF**

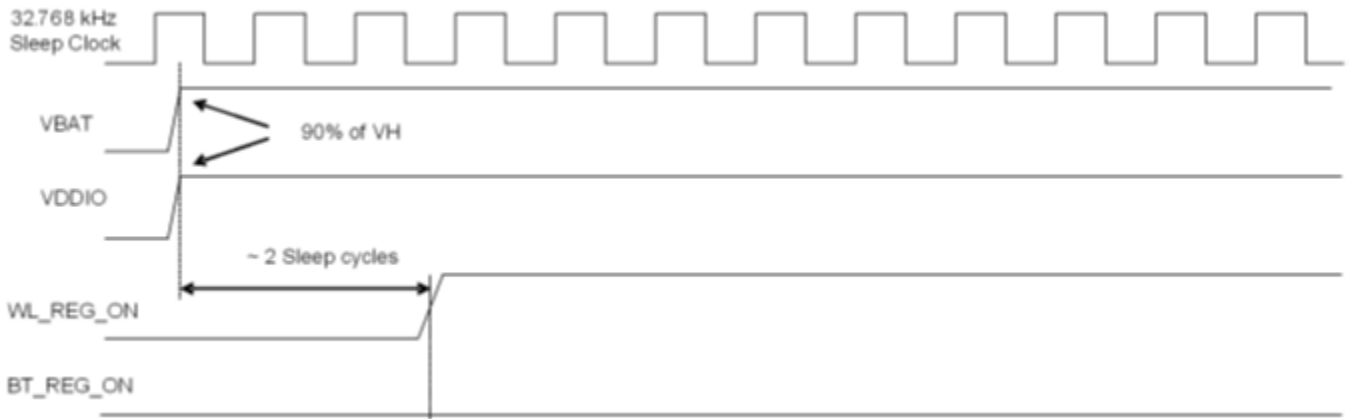

**Figure 13 WLAN = ON, Bluetooth = OFF**

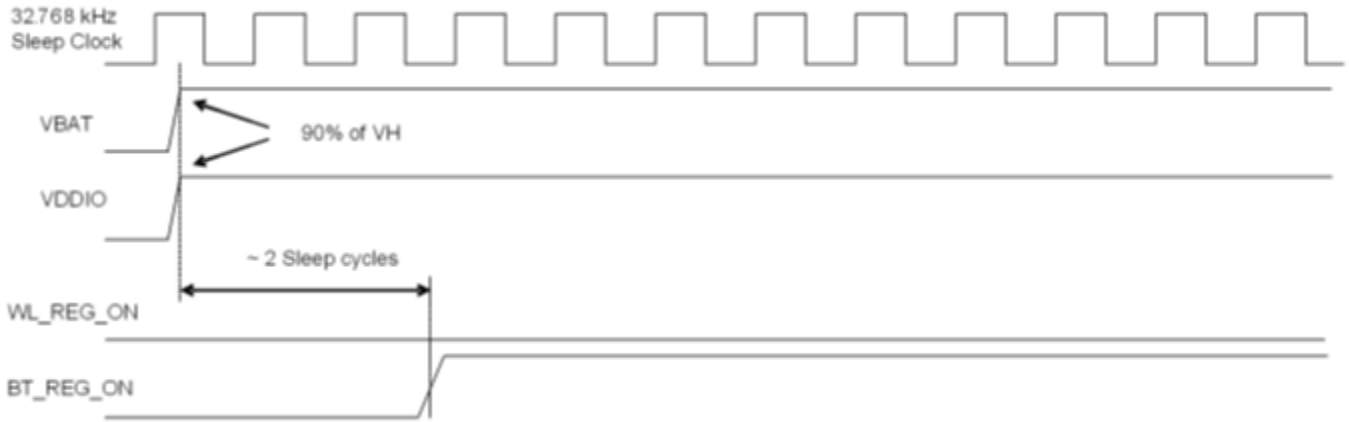

**Figure 14 WLAN = OFF, Bluetooth = ON**

**Note:** For both the WL\_REG\_ON and BT\_REG\_ON pins, there should be at least a 10 ms time delay between consecutive toggles (where both signals have been driven low). This is to allow time for the CBUCK regulator to discharge. If this delay is not followed, then there may be a VDDIO in-rush current on the order of 36 mA during the next PMU cold start.

**WLAN RF Characteristics**

**WLAN Transmitter Characteristics (TA = +25°C, VCC = 3.3 V)**

Parameter	Test Conditions	Min	Typ	Max	Unit
1 Mbps DSSS (b) TX Output Power	1 Mbps BPSK 802.11(b) Mask Compliance 35% EVM RMS power over TX packet	-	17.5	-	dBm
2 Mbps DSSS (b) TX Output Power	2 Mbps QPSK 802.11(b) Mask Compliance 35% EVM RMS power over TX packet	-	17.5	-	dBm
5.5 Mbps DSSS (b) TX Output Power	5.5 Mbps QPSK 802.11(b) Mask Compliance 35% EVM RMS power over TX packet	-	17.5	-	dBm
11 Mbps DSSS (b) TX Output Power	11 Mbps CCK 802.11(b) Mask Compliance 35% EVM RMS power over TX packet	-	17.5	-	dBm
6 Mbps OFDM (g) TX Output Power	6 Mbps BPSK 802.11(g) Mask Compliance -5 dB EVM RMS power over TX packet	-	14.0	-	dBm
9 Mbps OFDM (g) TX Output Power	9 Mbps BPSK 802.11(g) Mask Compliance -8 dB EVM RMS power over TX packet	-	14.0	-	dBm
12 Mbps OFDM (g) TX Output Power	12 Mbps QPSK 802.11(g) Mask Compliance -10 dB EVM RMS power over TX packet	-	14.0	-	dBm
18 Mbps OFDM (g) TX Output Power	18 Mbps QPSK 802.11(g) Mask Compliance -13 dB EVM RMS power over TX packet	-	14.0	-	dBm
24 Mbps OFDM (g) TX Output Power	24 Mbps 16-QAM 802.11(g) Mask Compliance -16 dB EVM RMS power over TX packet	-	14.0	-	dBm
36 Mbps OFDM (g) TX Output Power	36 Mbps 16-QAM 802.11(g) Mask Compliance -19 dB EVM RMS power over TX packet	-	14.0	-	dBm
48 Mbps OFDM (g) TX Output Power	48 Mbps 64-QAM 802.11(g) Mask Compliance -22 dB EVM RMS power over TX packet	-	14.0	-	dBm
54 Mbps OFDM (g) TX Output Power	54 Mbps 64-QAM 802.11(g) Mask Compliance -25 dB EVM RMS power over TX packet	-	14.0	-	dBm
MCS0 OFDM (n) TX Output Power	6.5 Mbps BPSK 802.11(n) Mask Compliance -5 dB EVM RMS power over TX packet	-	12.5	-	dBm
MCS1 OFDM (n) TX Output Power	13 Mbps QPSK 802.11(n) Mask Compliance -10 dB EVM RMS power over TX packet	-	12.5	-	dBm
MCS2 OFDM (n) TX Output Power	19.5 Mbps QPSK 802.11(n) Mask Compliance -13 dB EVM RMS power over TX packet	-	12.5	-	dBm
MCS3 OFDM (n) TX Output Power	26 Mbps 16-QAM 802.11(n) Mask Compliance -16 dB EVM RMS power over TX packet	-	12.5	-	dBm
MCS4 OFDM (n) TX Output Power	39 Mbps 16-QAM 802.11(n) Mask Compliance -19 dB EVM RMS power over TX packet	-	12.5	-	dBm
MCS5 OFDM (n) TX Output Power	52 Mbps 64-QAM 802.11(n) Mask Compliance -22 dB EVM RMS power over TX packet	-	12.5	-	dBm
MCS6 OFDM (n) TX Output Power	58.5 Mbps 64-QAM 802.11(n) Mask Compliance -25 dB EVM RMS power over TX packet	-	12.5	-	dBm
MCS7 OFDM (n) TX Output Power	65 Mbps 64-QAM 802.11(n) Mask Compliance -27 dB EVM RMS power over TX packet	-	12.5	-	dBm

**Table 13 WLAN Transmitter RF Characteristics**

The information in this document is subject to change without notice.

**WLAN Receiver Characteristics**  
(TA = +25°C, VCC = 3.3 V)

Parameter	Test Conditions	Min	Typ	Max	Unit
1 Mbps DSSS (b) RX Sensitivity	8% PER	-	-94	-	dBm
2 Mbps DSSS (b) RX Sensitivity	8% PER	-	-93	-	dBm
5.5 Mbps DSSS (b) RX Sensitivity	8% PER	-	-91	-	dBm
11 Mbps DSSS (b) RX Sensitivity	8% PER	-	-88	-	dBm
6 Mbps OFDM (g) RX Sensitivity	10% PER	-	-90	-	dBm
9 Mbps OFDM (g) RX Sensitivity	10% PER	-	-89	-	dBm
12 Mbps OFDM (g) RX Sensitivity	10% PER	-	-87	-	dBm
18 Mbps OFDM (g) RX Sensitivity	10% PER	-	-85	-	dBm
24 Mbps OFDM (g) RX Sensitivity	10% PER	-	-83	-	dBm
36 Mbps OFDM (g) RX Sensitivity	10% PER	-	-80	-	dBm
48 Mbps OFDM (g) RX Sensitivity	10% PER	-	-76	-	dBm
54 Mbps OFDM (g) RX Sensitivity	10% PER	-	-75	-	dBm
MCS0 (6.5 Mbps) OFDM (n) RX Sensitivity	10% PER	-	-89	-	dBm
MCS1 (13 Mbps) OFDM (n) RX Sensitivity	10% PER	-	-86	-	dBm
MCS2 (19.5 Mbps) OFDM (n) RX Sensitivity	10% PER	-	-84	-	dBm
MCS3 26 Mbps OFDM (n) RX Sensitivity	10% PER	-	-82	-	dBm
MCS4 39 Mbps OFDM (n) RX Sensitivity	10% PER	-	-79	-	dBm
MCS5 52 Mbps OFDM (n) RX Sensitivity	10% PER	-	-75	-	dBm
MCS6 58.5 Mbps OFDM (n) RX Sensitivity	10% PER	-	-73	-	dBm
MCS7 65 Mbps OFDM (n) RX Sensitivity	10% PER	-	-72	-	dBm
11b RX Overload Level	8% PER, 11 Mbps	-10	-	-	dBm
11g RX Overload Level	10% PER, 54 Mbps	-20	-	-	dBm
11n RX Overload Level	10% PER, MCS7	-20	-	-	dBm

**Table 14 WLAN Receiver RF Characteristics**

The information in this document is subject to change without notice.

## Bluetooth RF Characteristics

### Bluetooth Transmitter GFSK & EDR Characteristics (TA=25°C, VBAT=3.3 V)

Parameter	Test Conditions	Min	Typical	Max	Bluetooth Spec	Unit
GFSK RF Output Power		-	8.5	-		dBm
EDR RF Output Power		-	4.0	-		dBm
Power Control Step Size		2	4	8	2-8	dB
EDR Relative Power		-4		1	-4/+1	dB

**Table 15 Bluetooth**

### Bluetooth Receiver GFSK & EDR Characteristics (TA=25°C, VBAT=3.3 V)

Parameter	Test Conditions	Min	Typical	Max	Bluetooth Spec	Unit
GFSK Sensitivity	BER=0.1%	-	-90	-	-70	dBm
EDR 2 Mbps Sensitivity	BER=0.01%	-	-92	-	-70	dBm
EDR 3 Mbps Sensitivity	BER=0.01%	-	-87	-	-70	dBm
GFSK Maximum Input Level	BER=0.1%	-	-20	-	-20	dBm
EDR 2 Maximum Input Level	BER=0.01%	-	-20	-	-	dBm
EDR 3 Maximum Input Level	BER=0.01%	-	-20	-	-	dBm

**Table 16 Bluetooth**

### BLE Transmitter Characteristics (TA=25°C, VBAT=3.3 V)

Parameter	Test Conditions	Min	Typical	Max	Bluetooth Spec	Unit
GFSK RF Output Power		-	7.5	-		dBm
Power Control Step Size		2	4	8	2-8	dB

**Table 17 Bluetooth**

### BLE Receiver Characteristics (TA=25°C, VBAT=3.3 V)

Parameter	Test Conditions	Min	Typical	Max	Bluetooth Spec	Unit
GFSK Sensitivity	PER = 30.8%	-	-94	-	-70	dBm
GMSK Maximum Input Level	PER = 30.8%	-	-20	-	-20	dBm

**Table 18 Bluetooth**

The information in this document is subject to change without notice.

**WLAN HOST INTERFACE**

**SDIO Interface**

**Overview**

The Sterling-LWB Module WLAN section supports SDIO version 2.0. for both 1-bit (25 Mbps) and 4-bit modes (100 Mbps), as well as high speed 4-bit mode (50 MHz clocks—200 Mbps).

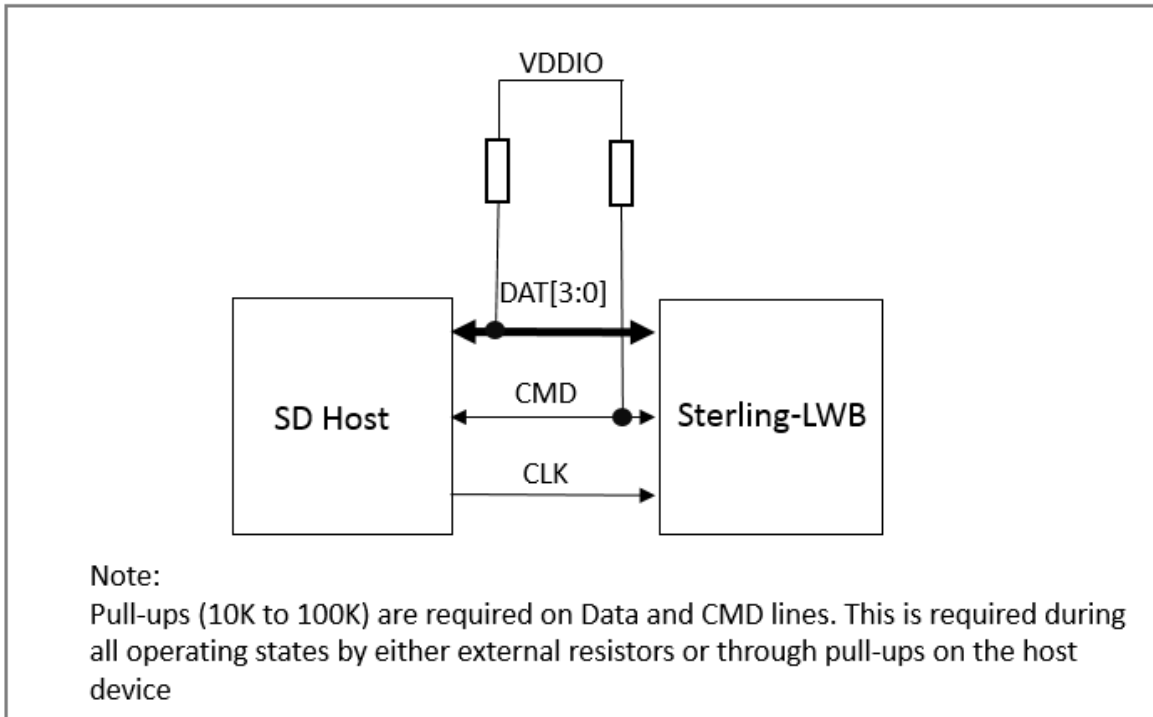

**Figure 15 Signal Connections to SDIO Host (SD 4-Bit Mode)**

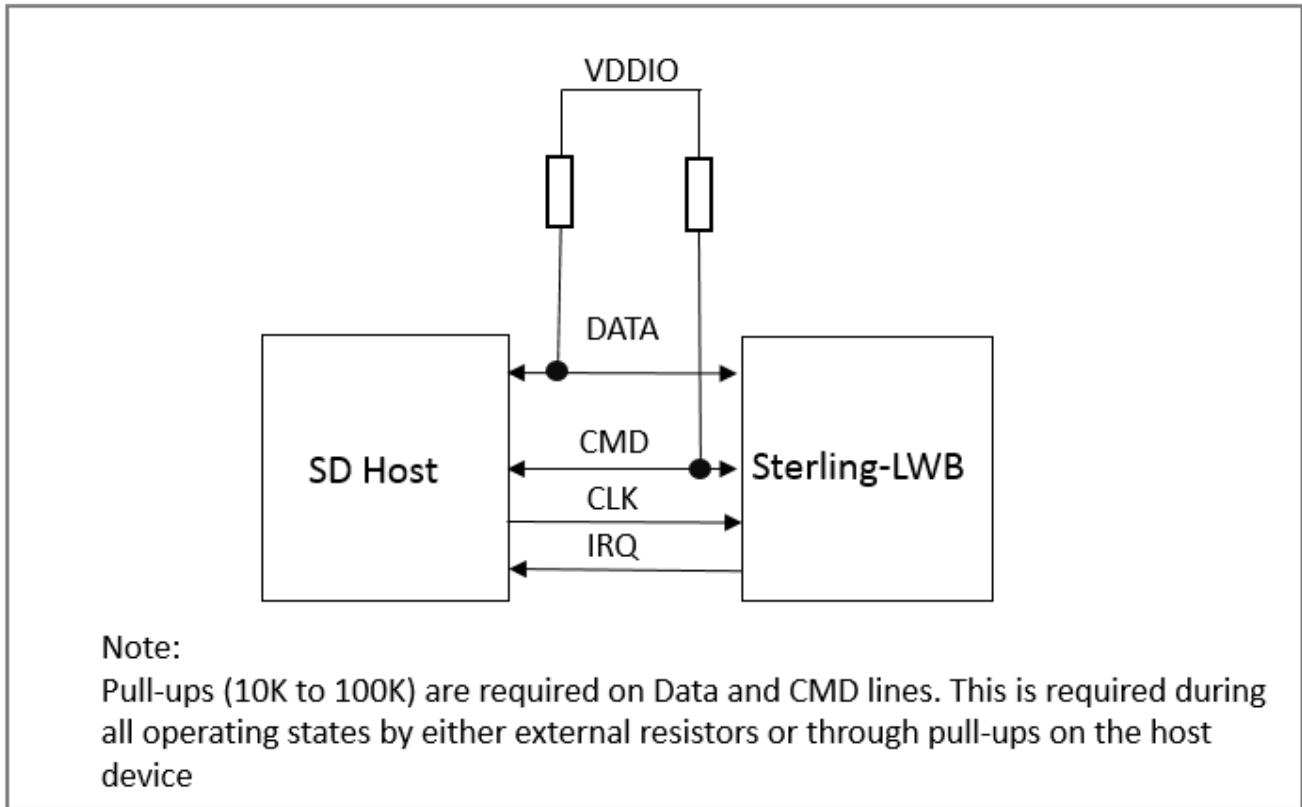
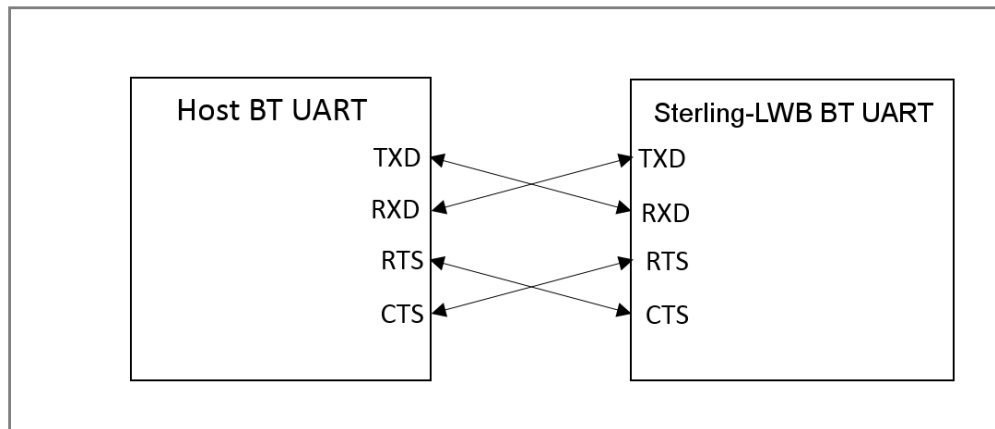

**Figure 16 Signal Connections to SDIO Host (SD 1-Bit Mode)**

## BLUETOOTH UART HOST INTERFACE

### Overview

The Sterling-LWB uses a single UART for Bluetooth. The UART is a standard 4-wire interface (RX, TX, RTS, and CTS) with adjustable baud rates from 9600 bps to 4.0 Mbps. The interface features an automatic baud rate detection capability that returns a baud rate selection. The baud rate may be selected through a vendor-specific UART HCI command to a value other than the default rate of 115.2 kbps.



**Figure 17 UART Connection from Sterling-LWB to Host**

## Soldering Recommendations

### Reflow for Lead Free Solder Paste

- Optimal solder reflow profile depends on solder paste properties and should be optimized as part of an overall process development.
- It is important to provide a solder reflow profile that matches the solder paste supplier's recommendations.
- Temperature ranges beyond that of the solder paste supplier's recommendation could result in poor solderability.
- All solder paste suppliers recommend an ideal reflow profile to give the best solderability.

### Recommended Reflow Profile for Lead Free Solder

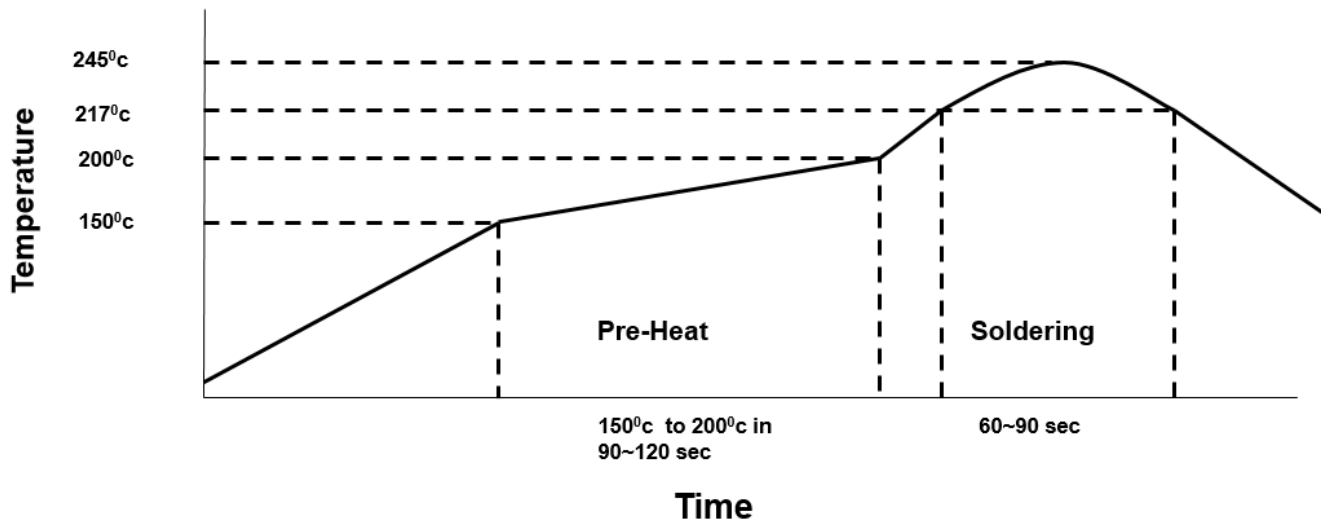

Figure 18 Recommended Soldering Profile

**Note: The quality of solder joints on the surface mount pads where they contact the host board should meet the appropriate IPC Specification. See IPC-A-610-D Acceptability of Electronic Assemblies, section 8.2.1 "Bottom Only Terminations."**

**WiFi MAC IDs/BLUETOOTH MAC IDs**

LSR has procured a block of IEEE MAC Address from the IEEE association. The MAC addresses are six (6) bytes in length and the three (3) Most Significant Bytes (MSBs) are the OUI, which is used to identify the company to which the block of IEEE addresses was assigned. LSR’s OUI is **00:25:CA**.

For the Sterling-LWB, the WiFi MAC ID and Bluetooth MAC ID is preprogrammed during production for each module. The Bluetooth MAC ID is the WiFi MAC ID plus one.

**Example:**

	<b>WiFi MAC ID</b>	<b>Bluetooth MAC ID</b>
<b>Module 1</b>	00:25:CA:07:00:01	00:25:CA:07:00:02
<b>Module 2</b>	00:25:CA:07:00:03	00:25:CA:07:00:04
<b>Module 3</b>	00:25:CA:07:00:05	00:25:CA:07:00:06
<b>Module 4</b>	00:25:CA:07:00:07	00:25:CA:07:00:08

**Table 19 Example MAC ID Assignments**

The information in this document is subject to change without notice.

## CLEANING

In general, cleaning the populated modules is strongly discouraged. Residuals under the module cannot be easily removed with any cleaning process.

- Cleaning with water can lead to capillary effects where water is absorbed into the gap between the host board and the module. The combination of soldering flux residuals and encapsulated water could lead to short circuits between neighboring pads. Water could also damage any stickers or labels.
- Cleaning with alcohol or a similar organic solvent will likely flood soldering flux residuals into the RF shield, which is not accessible for post-washing inspection. The solvent could also damage any stickers or labels.
- Ultrasonic cleaning could damage the module permanently.

## OPTICAL INSPECTION

After soldering the Module to the host board, consider optical inspection to check the following:

- Proper alignment and centering of the module over the pads.
- Proper solder joints on all pads.
- Excessive solder or contacts to neighboring pads, or vias.

## REWORK

The Sterling-LWB module can be unsoldered from the host board if the Moisture Sensitivity Level (MSL) requirements are met as described in this datasheet.

**Never attempt a rework on the module itself, e.g. replacing individual components. Such actions will terminate warranty coverage.**

## SHIPPING, HANDLING, AND STORAGE

### Shipping

Bulk orders of the Sterling-LWB base module are delivered in reels of 2000. Bulk orders for the antenna option PCBAs are delivered in reels of 1000.

### Handling

The Sterling-LWB modules contain a highly sensitive electronic circuitry. Handling without proper ESD protection may damage the module permanently.

### Moisture Sensitivity Level (MSL)

Per J-STD-020, devices rated as MSL 4 and not stored in a sealed bag with desiccant pack should be baked prior to use.

Devices are packaged in a Moisture Barrier Bag with a desiccant pack and Humidity Indicator Card (HIC). Devices that will be subjected to reflow should reference the HIC and J-STD-033 to determine if baking is required.

If baking is required, refer to J-STD-033 for bake procedure.

### Storage

Per J-STD-033, the shelf life of devices in a Moisture Barrier Bag is 12 months at <40C and <90% room humidity (RH).

Do not store in salty air or in an environment with a high concentration of corrosive gas, such as Cl<sub>2</sub>, H<sub>2</sub>S, NH<sub>3</sub>, SO<sub>2</sub>, or NO<sub>x</sub>.

Do not store in direct sunlight.

The product should not be subject to excessive mechanical shock.

### **Repeated Reflow Soldering**

**Only a single reflow soldering process is encouraged for host boards.**

## AGENCY CERTIFICATIONS

FCC ID: TFB-1003, 15.247

IC ID: 5969A-1003, RSS 247

CE: Compliant to standards EN 60950-1, EN 300 328, and EN 301 489

Giteki: 209-J00212

RCM: Compliant to standards EN 300 328 V1.9.1, AS/NZS 4268: 2012-A1:2013, and EN 55022:2010/AC:2011

## AGENCY STATEMENTS

### Federal Communication Commission Interference Statement

This equipment has been tested and found to comply with the limits for a Class B digital device, pursuant to Part 15 of the FCC Rules. These limits are designed to provide reasonable protection against harmful interference in a residential installation. This equipment generates uses and can radiate radio frequency energy and, if not installed and used in accordance with the instructions, may cause harmful interference to radio communications. However, there is no guarantee that interference will not occur in a particular installation. If this equipment does cause harmful interference to radio or television reception, which can be determined by turning the equipment off and on, the user is encouraged to try to correct the interference by one of the following measures:

- Reorient or relocate the receiving antenna.
- Increase the separation between the equipment and receiver.
- Connect the equipment into an outlet on a circuit different from that to which the receiver is connected.
- Consult the dealer or an experienced radio/TV technician for help.

This device complies with Part 15 of the FCC Rules. Operation is subject to the following two conditions: (1) This device may not cause harmful interference, and (2) this device must accept any interference received, including interference that may cause undesired operation.

**FCC CAUTION:** Any changes or modifications not expressly approved by the party responsible for compliance could void the user's authority to operate this equipment.

## Industry Canada Statements

This Device complies with Industry Canada License-exempt RSS standard(s). Operation is subject to the following two conditions: (1) this device may not cause interference, and (2) this device must accept any interference, including interference that may cause undesired operation of the device.

To reduce potential radio interference to other users, the antenna type and its gain should be so chosen that the equivalent isotropically radiated power (e.i.r.p.) is not more than that permitted for successful communication.

This device has been designed to operate with the antenna(s) listed below, and having a maximum gain of 2.0 dBi (LSR Dipole), 2.0 dBi (LSR FlexPIFA), 2.0 dBi (LSR FlexNotch), 2.0 dBi (LSR mFlexPIFA), and 1.5 dBi (Johanson Chip). Antennas not included in this list or having a gain greater than 2.0 dBi, 2.0 dBi, 2.0 dBi, 2.0 dBi, and 1.5 dBi are strictly prohibited for use with this device. The required antenna impedance is 50 ohms.

List of all Antennas Acceptable for use with the Transmitter

- 1) LSR 001-0001 center-fed 2.4 GHz dipole antenna and LSR 080-0001 U.FL to Reverse Polarity SMA connector cable.
- 2) LSR 001-0014 2.4 GHz FlexPIFA antenna.
- 3) LSR 001-0015 2.4 GHz FlexNotch antenna.
- 4) LSR 001-0030 2.4 GHz Metal FlexPIFA (mFlexPIFA) antenna.
- 5) Johanson Technology 2450AT18D0100 chip antenna.

Cet appareil est conforme avec Industrie Canada, exempts de licence standard RSS (s). L'opération est soumise aux deux conditions suivantes: (1) cet appareil ne peut pas provoquer d'interférences et (2) cet appareil doit accepter toute interférence, y compris les interférences qui peuvent causer un mauvais fonctionnement de l'appareil.

Pour réduire le risque d'interférence aux autres utilisateurs, le type d'antenne et son gain doivent être choisis de manière que la puissance isotrope rayonnée équivalente (PIRE) ne dépasse pas celle permise pour une communication réussie.

Cet appareil a été conçu pour fonctionner avec l'antenne (s) ci-dessous, et ayant un gain maximum de 2,0 dBi (LSR Dipole), 2,0 dBi (LSR FlexPIFA), 2,0 dBi (LSR FlexNotch), 2,0 dBi (LSR mFlexPIFA), et 1,5 dBi (Johanson Chip). Antennes pas inclus dans cette liste ou présentant un gain supérieure à 2,0 dBi, 2,0 dBi, 2,0 dBi, 2,0 dBi, et 1,5 dBi sont strictement interdits pour une utilisation avec cet appareil. L'impédance d'antenne requise est de 50 ohms.

Liste de toutes les antennes acceptables pour une utilisation avec l'émetteur

- 1) Antenne LSR 001-0001 2.4 GHz de centre-dipôle alimenté et LSR 080-0001 U.FL inverser câble connecteur SMA à polarité.
- 2) LSR 001-0014 antenne FlexPIFA 2,4 GHz w/U.FL câble.
- 3) LSR 001-0015 antenne FlexNotch 2,4 GHz w/U.FL câble.
- 4) LSR 001-0030 antenne Métal FlexPIFA (mFlexPIFA) 2,4 GHz.
- 5) Antenne de puce Johanson Technology 2450AT18D0100.

---

The information in this document is subject to change without notice.

## OEM RESPONSIBILITIES TO COMPLY WITH FCC AND INDUSTRY CANADA REGULATIONS

The Sterling-LWB Module has been certified for integration into products only by OEM integrators under the following conditions:

To comply with FCC and Industry Canada RF exposure limits for general population / uncontrolled exposure, the antenna must be installed to provide a separation distance of at least 29mm from all persons and operating in conjunction with any other antenna or transmitter, except in accordance with FCC multi-transmitter product procedures.

As long as the two conditions above are met, further transmitter testing will not be required. However, the OEM integrator is still responsible for testing their end-product for any additional compliance requirements required with this module installed (for example, digital device emissions, PC peripheral requirements, etc.).

**IMPORTANT NOTE: In the event that these conditions cannot be met (for certain configurations or co-location with another transmitter), then the FCC and Industry Canada authorizations are no longer considered valid and the FCC ID and IC Certification Number cannot be used on the final product. In these circumstances, the OEM integrator will be responsible for re-evaluating the end product (including the transmitter) and obtaining a separate FCC and Industry Canada authorization.**

Le module de Sterling-LWB a été certifié pour l'intégration dans des produits uniquement par des intégrateurs OEM dans les conditions suivantes:

Pour se conformer aux limites d'exposition aux RF de la FCC et d'Industrie Canada pour la population générale / exposition non contrôlée, l'antenne doit être installée pour fournir une distance de séparation d'au moins 29mm de toutes les personnes et fonctionnant conjointement avec une autre antenne ou émetteur, sauf en conformité avec la FCC procédures de produits multi- émetteurs.

Tant que les deux conditions précitées sont réunies, les tests de transmetteurs supplémentaires ne seront pas tenus. Toutefois, l'intégrateur OEM est toujours responsable de tester leur produit final pour toutes les exigences de conformité supplémentaires requis avec ce module installé (par exemple, les émissions appareil numérique, les exigences de périphériques PC, etc.)

**NOTE IMPORTANTE: Dans le cas où ces conditions ne peuvent être satisfaites (pour certaines configurations ou de co-implantation avec un autre émetteur), puis la FCC et Industrie autorisations Canada ne sont plus considérés comme valides et l'ID de la FCC et IC numéro de certification ne peut pas être utilisé sur la produit final. Dans ces circonstances, l'intégrateur OEM sera chargé de réévaluer le produit final (y compris l'émetteur) et l'obtention d'un distincte de la FCC et Industrie Canada l'autorisation.**

---

## OEM LABELING REQUIREMENTS FOR END-PRODUCT

The Sterling-LWB module is labeled with its own FCC ID and IC Certification Number. The FCC ID and IC certification numbers are not visible when the module is installed inside another device, as such the end device into which the module is installed must display a label referring to the enclosed module. The final end product must be labeled in a visible area with the following:

**“Contains Transmitter Module FCC ID: TFB-1003”**

**“Contains Transmitter Module IC: 5969A-1003”**

or

**“Contains FCC ID: TFB-1003”**

**“Contains IC: 5969A-1003”**

The OEM of the Sterling-LWB Module must only use the approved antenna(s) listed above, which have been certified with this module.

Le module de Sterling-LWB est étiqueté avec son propre ID de la FCC et IC numéro de certification. L'ID de la FCC et IC numéros de certification ne sont pas visibles lorsque le module est installé à l'intérieur d'un autre appareil, comme par exemple le terminal dans lequel le module est installé doit afficher une étiquette faisant référence au module ci-joint. Le produit final doit être étiqueté dans un endroit visible par le suivant:

**“Contient Module émetteur FCC ID: TFB-1003”**

**“Contient Module émetteur IC: 5969A-1003”**

ou

**“Contient FCC ID: TFB-1003”**

**“Contient IC: 5969A-1003”**

Les OEM du module Sterling-LWB ne doit utiliser l'antenne approuvée (s) ci-dessus, qui ont été certifiés avec ce module.

## **OEM END PRODUCT USER MANUAL STATEMENTS**

The OEM integrator should not to provide information to the end user regarding how to install or remove this RF module or change RF related parameters in the user manual of the end product.

**The user manual for the end product must include the following information in a prominent location:**

To comply with FCC and Industry Canada RF exposure limits for general population / uncontrolled exposure, the antenna(s) used for this transmitter must be installed to provide a separation distance of at least 29mm from all persons and operating in conjunction with any other antenna or transmitter, except in accordance with FCC multi-transmitter product procedures.

Other user manual statements may apply.

L'intégrateur OEM ne devraient pas fournir des informations à l'utilisateur final sur la façon d'installer ou de supprimer ce module RF ou modifier les paramètres liés RF dans le manuel utilisateur du produit final.

**Le manuel d'utilisation pour le produit final doit comporter les informations suivantes dans un endroit bien en vue:**

Pour se conformer aux limites d'exposition aux RF de la FCC et d'Industrie Canada pour la population générale / exposition non contrôlée, l'antenne(s) utilisée pour ce transmetteur doit être installé pour fournir une distance de séparation d'au moins 29mm de toutes les personnes et fonctionnant conjointement avec une autre antenne ou émetteur, sauf en conformité avec les procédures de produits multi-émetteur FCC.

Autres déclarations manuel de l'utilisateur peuvent s'appliquer.

## EUROPE

### CE Notice

This device has been tested and certified for use in the European Union. See the Declaration of Conformity (DOC) for specifics.

If this device is used in a product, the OEM has responsibility to verify compliance of the final product to the EU standards. A Declaration of Conformity must be issued and kept on file as described in the Radio and Telecommunications Terminal Equipment (R&TTE) Directive.

The 'CE' mark must be placed on the OEM product per the labeling requirements of the Directive.

### Declaration of Conformity (DOC)

This DOC can be downloaded from the LSR Website.

## AUSTRALIA

### RCM

<p><b>Radiocommunications (Short Range Devices) Standard 2014 (Amnt 1:2015)</b>  <b>Radiocommunications (Low Interference Potential Device) Class License 2015</b></p> <p>AS/NZS 4268: 2012-A1:2013  EN 300328 V1.9.1  Report No.: 316052 (316051), Dated: 21 July 2016, LS Research</p>
<p><b>Radiocommunications (Electromagnetic Compatibility) Standard 2008</b></p> <p>EN 55022 : 2010/AC :2011  Information Technology Equipment – Radio disturbance characteristics – Limits and methods measurement  Report No. : TR 316051 B, dated : 6 July 2016, LS Research</p>
<p><b>Radiocommunications (Electromagnetic Radiation – Human Exposure) Standard 2014</b></p> <p>Maximum Exposure Levels to Radio Frequency Fields – 3 KHz to 300 GHz (2002) RPS 3, ARPANSA  Category B Exemption – Fixed Station Exemption, ARPANSA Schedule 5, General Public Exposure, &lt;20mW Mean Power,  Or no antenna near the body (&gt;20cm from unaware user) and mean output power does not exceed Table 2 threshold for testing.</p>

**Table 20 AU/NZS Certification**

If this device is used in a product, the OEM has responsibility to verify compliance of the final end product to the Australia/New Zealand (RCM) Standards. All end-products require their own certification (SDoc). You will not be able to leverage the module certification and ship product into the country.

## BLUETOOTH SIG QUALIFICATION

### Overview

The Sterling-LWB module is listed on the Bluetooth SIG website as a qualified Controller Subsystem.

Design Name	Owner	Declaration ID	Link to listing on the SIG website
450-0159	Laird	D031500	<a href="#">Sterling-LWB 450-0159</a>
450-0148	Laird	D031500	<a href="#">Sterling-LWB 450-0148</a>
450-0152	Laird	D031500	<a href="#">Sterling-LWB 450-0152</a>

**Table 21 Sterling-LWB Declaration ID**

It is a mandatory requirement of the Bluetooth Special Interest Group (SIG) that every product implementing Bluetooth technology has a Declaration ID. Every Bluetooth design is required to go through the qualification process, even when referencing a Bluetooth Design that already has its own Declaration ID. The Qualification Process requires each company to register as a member of the Bluetooth SIG – [www.bluetooth.org](http://www.bluetooth.org)

The following is a link to the Bluetooth Registration page: <https://www.bluetooth.org/login/register/>

For each Bluetooth Design it is necessary to purchase a Declaration ID. This can be done before starting the new qualification, either through invoicing or credit card payment. The fees for the Declaration ID will depend on your membership status, please refer to the following webpage:

<https://www.bluetooth.org/en-us/test-qualification/qualification-overview/fees>

For a detailed procedure of how to obtain a new Declaration ID for your design, please refer to the following SIG document, (login is required to view this document):

[https://www.bluetooth.org/DocMan/handlers/DownloadDoc.ashx?doc\\_id=283698&vId=317486](https://www.bluetooth.org/DocMan/handlers/DownloadDoc.ashx?doc_id=283698&vId=317486)

### Qualification Steps When Referencing a Laird Controller Subsystem Design

To qualify your product when referencing a Laird Controller Subsystem design, follow these steps:

1. To start a listing, go to: [https://www.bluetooth.org/tpg/QLI\\_SDoc.cfm](https://www.bluetooth.org/tpg/QLI_SDoc.cfm)

**Note: A user name and password are required to access this site.**

2. In step 1, select the option, New Listing and Reference a Qualified Design.
3. Enter 85005 in the Controller Subsystem table entry.
4. Enter your complimentary Host Subsystem and optional Profile Subsystem in the table entry.
5. Select your pre-paid Declaration ID from the drop down menu or go to the Purchase Declaration ID page.

The information in this document is subject to change without notice.

**Note: Unless the Declaration ID is pre-paid or purchased with a credit card, you cannot proceed until the SIG invoice is paid.**

6. Once all the relevant sections of step 1 are finished, complete steps 2, 3, and 4 as described in the help document accessible from the site.

Your new design will be listed on the SIG website and you can print your Certificate and SDoC.

For further information please refer to the following training material:

<https://www.bluetooth.org/en-us/test-qualification/qualification-overview/listing-process-updates>

### **Additional Assistance**

Please contact your local sales representative or our support team for further assistance:

Laird Technologies Connectivity Products Business Unit  
Support Centre: <http://ews-support.lairdtech.com>

Email: [wireless.support@lairdtech.com](mailto:wireless.support@lairdtech.com)

Phone: Americas: +1-800-492-2320  
Europe: +44-1628-858-940  
Hong Kong: +852 2923 0610

Web: <http://www.lairdtech.com/bluetooth>

**BASE SIP MODULE MECHANICAL DATA**

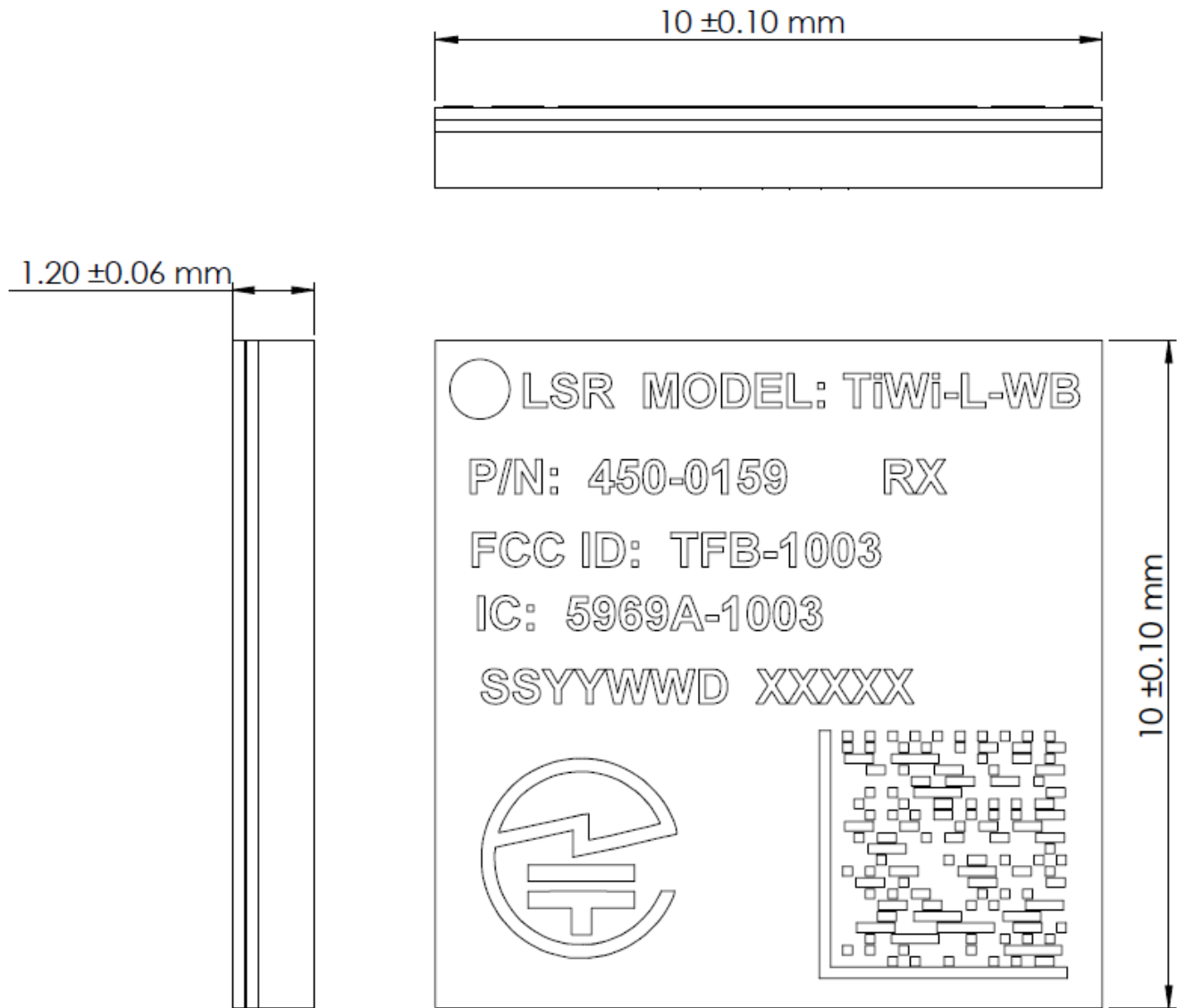

**Figure 19 Base SIP Module Mechanical Dimensions**

**BASE SIP MODULE PCB FOOTPRINT**

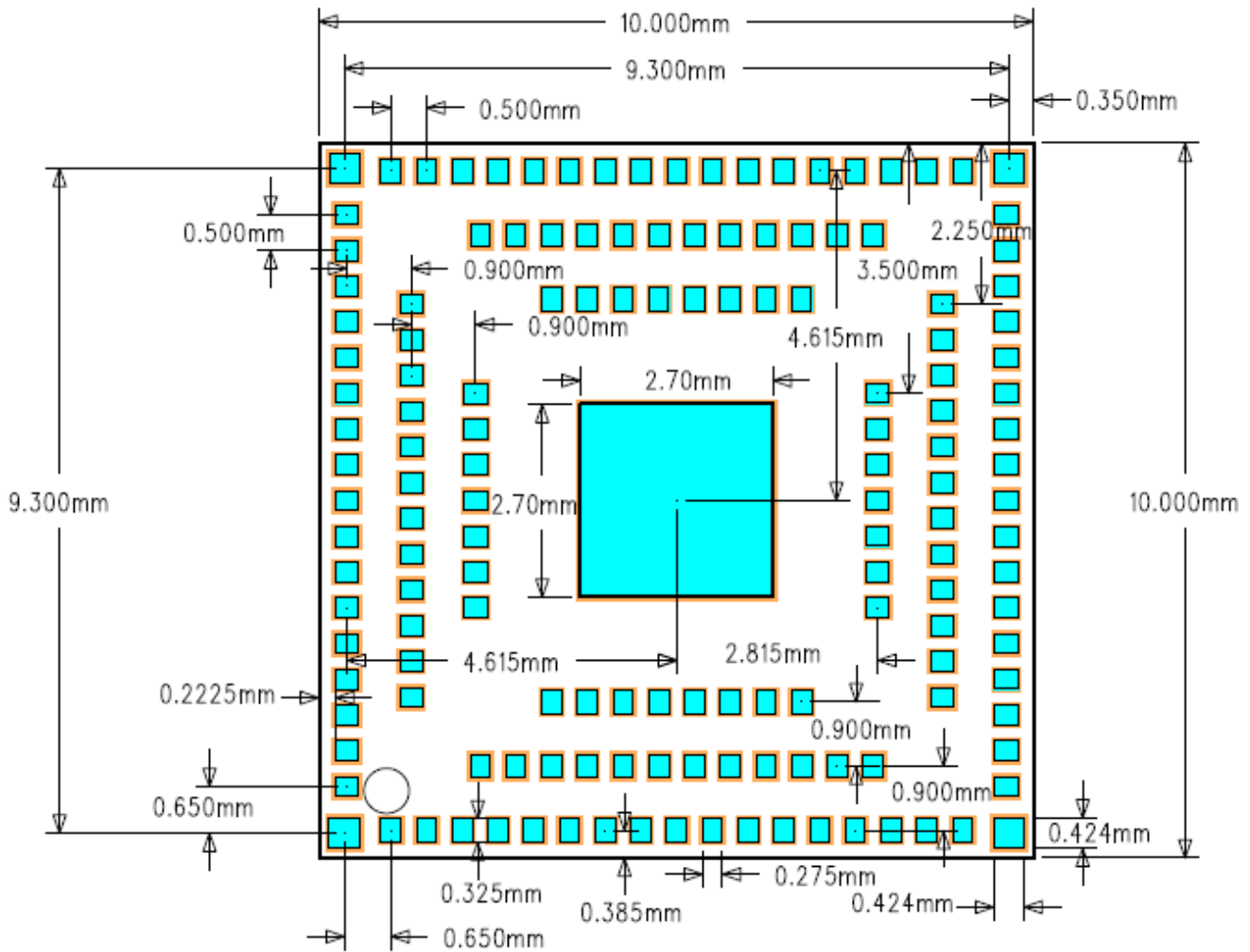

©

**Figure 20 Base SIP Module Footprint (Top View)**

**Note:**

Three Pad Sizes	Solder Mask
Type A - 0.424 x 0.424 mm	0.524 x 0.524 mm
Type B - 0.275 x 0.325 mm	0.35 x 0.40mm
Type C - 2.7 x 2.7 mm	2.8 x 2.8 mm

**BASE SIP MODULE RECOMMENDED SOLDER STENCIL**

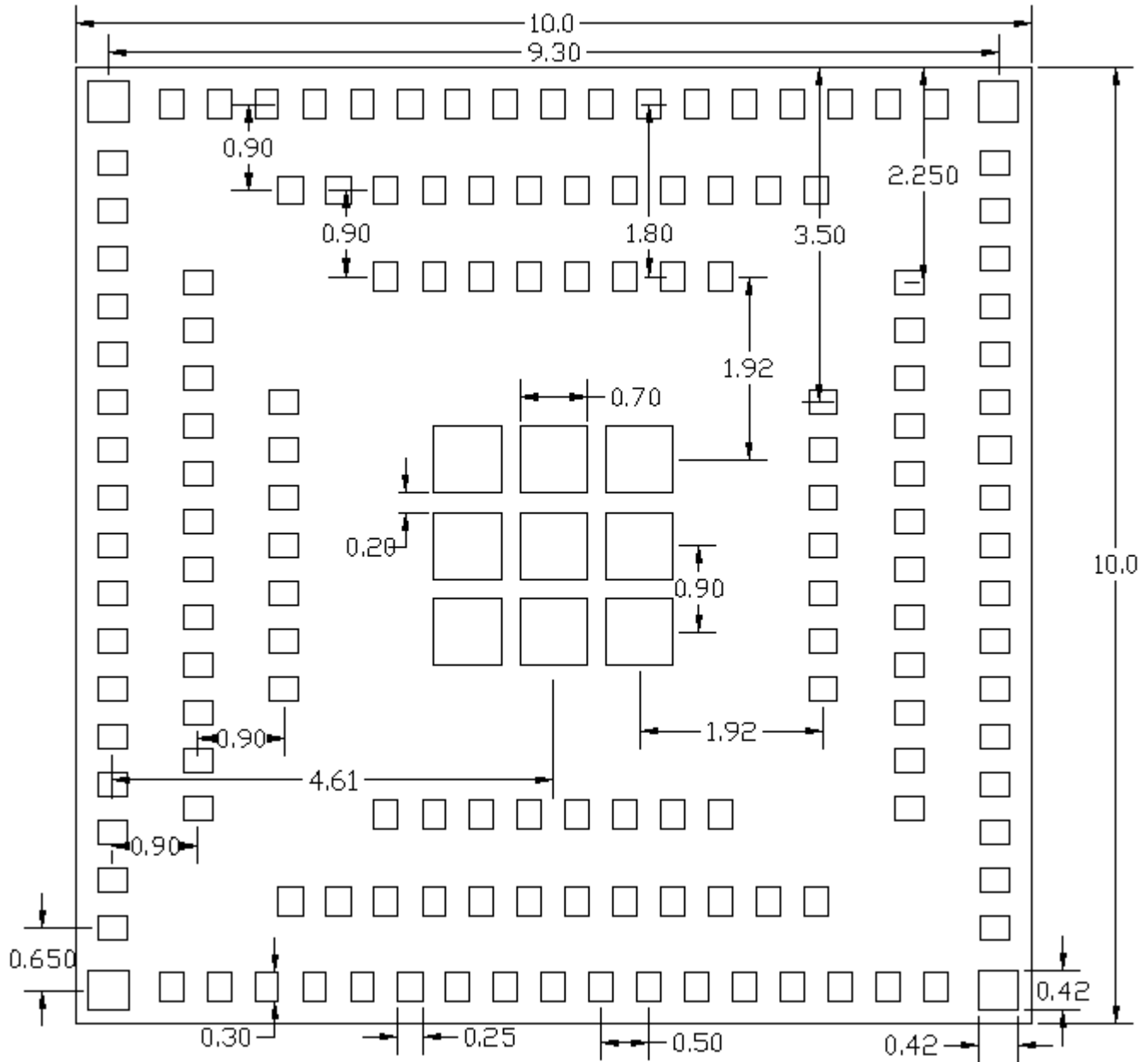
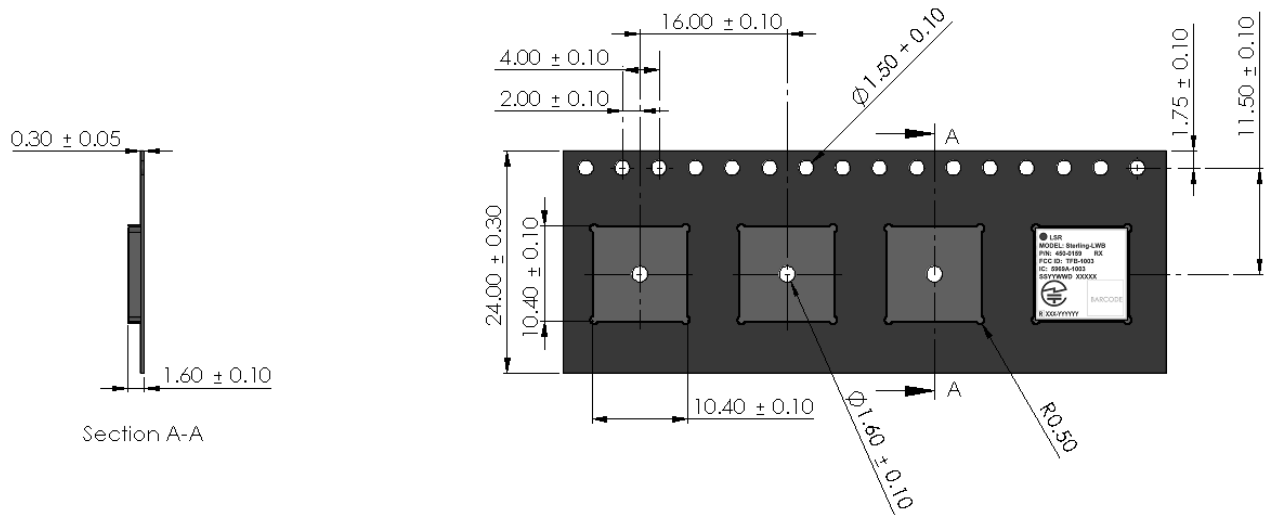

**Figure 21 – Base SiP Module Recommended Solder Stencil (Top View)**

**Note:** Solder Mask and Paste Mask to be adjusted according to end users assembly process

**BASE SIP MODULE TAPE AND REEL PACKAGING**

**Tape Dimensions**



- NOTES:
1. DIM in mm.
  2. 10 Sprocket Hole Pitch Cumulative Tolerance  $\pm 0.20$  mm.
  3. Pocket Position Relative to Sprocket Hole Measured as True Position of Pocket, not Pocket Hole
  4. A Full Reel contains 2000 modules.

(Module must be in this Orientation when Feeding Tape)

**Figure 22 Base SiP Module Tape and Reel Specification**

**U.FL AND CHIP ANTENNA MECHANICAL DATA**

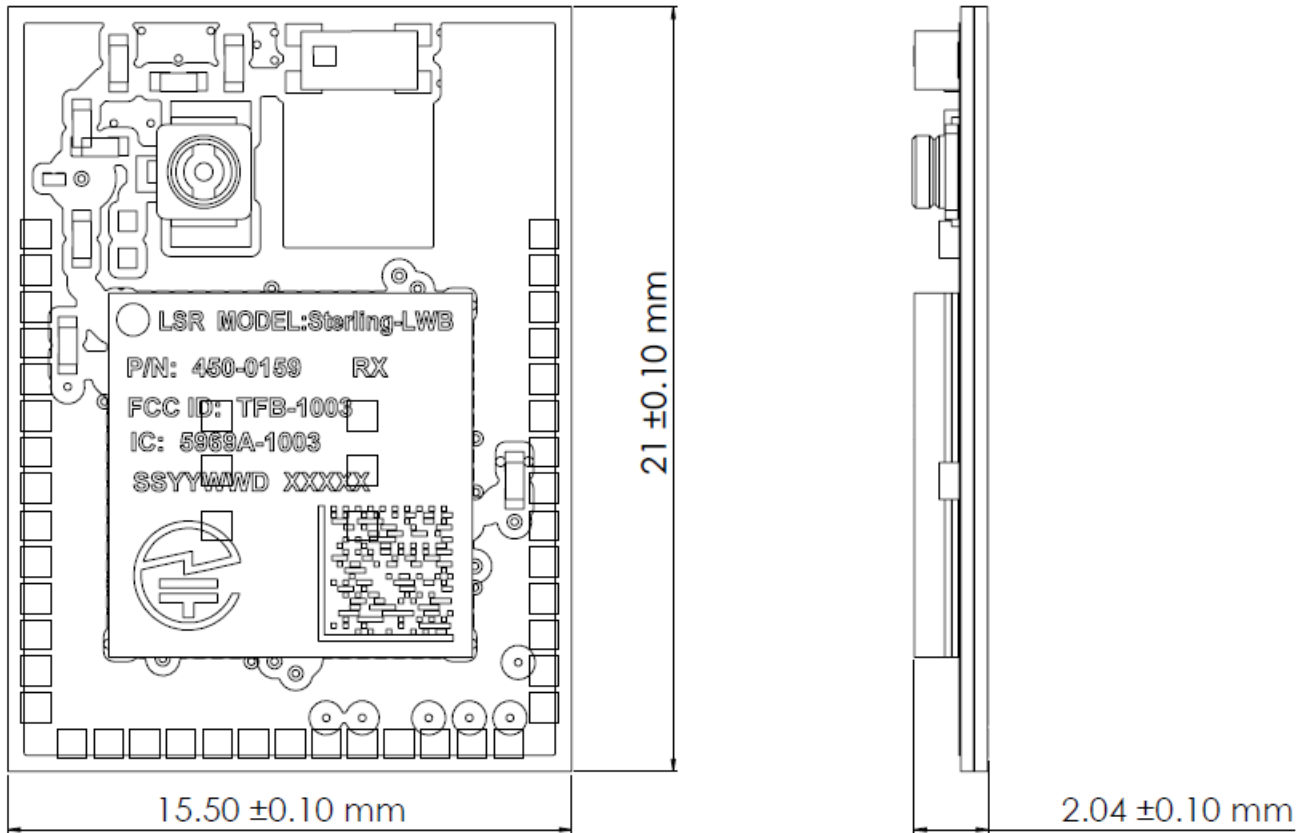
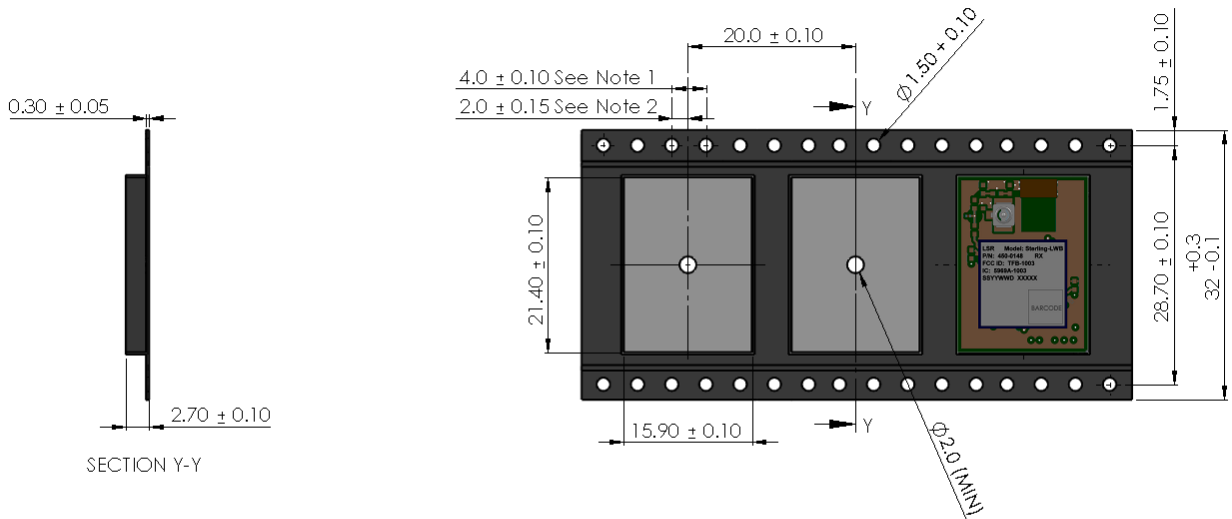

**Figure 23 U.FL and Chip Antenna Mechanical Dimensions**



**U.FL AND CHIP ANTENNA TAPE AND REEL PACKAGING**

**Tape Dimensions**



- NOTES:  
 1. DIM in mm.  
 2. 10 Sprocket Hole Pitch Cumulative Tolerance  $\pm 0.1$ mm.  
 3. Pocket Position Relative to Sprocket Hole Measured as True Position of Pocket, not Pocket Hole  
 4. A Full Reel contains 1000 modules.

(Module must be in this Orientation when Feeding Tape)

**Figure 25 U.FL and Chip Antenna Modules Tape and Reel Specification**

**DEVICE MARKINGS**

**SiP Module**

**Rev 1 Devices**

- Initial Release

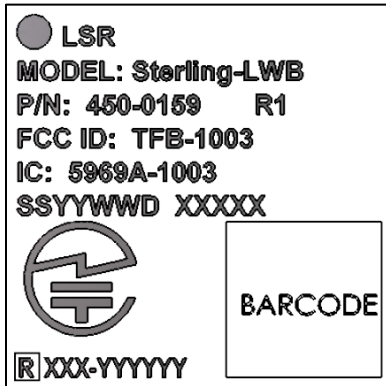

The shield on the 450-0159 modules contains the following information:

- ● Pin 1 Indicator
- LSR
- MODEL: STERLING-LWB
- Part Number and Revision:
  - P/N: 450-0159
  - R1 = Revision 1
- FCC ID: TFB-1003
- IC: 5969A-1003
- SSYYWWD = Date Code (SS=Manufacturer, YY=Year, WW=Week, D=Day)
- XXXXX = Incremental Serial Number
- 2D Barcode Format is Data Matrix Standard
-  Giteki Logo
- Giteki Symbol of Radio Certification: R in the Square Box
- XXX-YYYYYY = Giteki Certification Type Number: 209-J00212. 209 is the CAB ID assigned by the Minister of MIC. J00212 is the Certification Number assigned by the CAB.

**Rev 2 Devices**

- Added RCM (C-Tick) (Australia/New Zealand Certification) Logo
- Added TM (Trademark) Logo



The shield on the 450-0159 modules contains the following information:

- ● Pin 1 Indicator
- LSR
- MODEL: STERLING-LWB
- Part Number and Revision:
  - P/N: 450-0159
  - R1 = Revision 1
- FCC ID: TFB-1003
- IC: 5969A-1003
- SSYYWWD = Date Code (SS=Manufacturer, YY=Year, WW=Week, D=Day)
- XXXXX = Incremental Serial Number
- 2D Barcode Format is Data Matrix Standard
-  Giteki Logo
- Giteki Symbol of Radio Certification: R in the Square Box
- XXX-YYYYYY = Giteki Certification Type Number: 209-J00212. 209 is the CAB ID assigned by the Minister of MIC. J00212 is the Certification Number assigned by the CAB.
-  RCM Logo (Australia/New Zealand Certification)
- ™ = Trademark Logo

## Antenna Option Modules

### Rev 1 Devices

- Initial Release

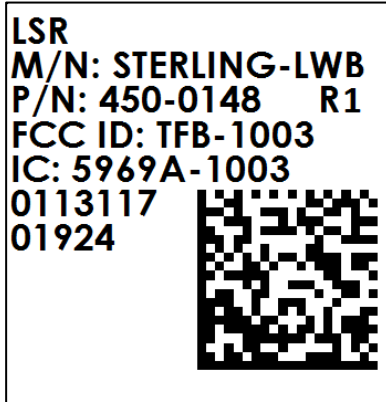

The shield on the 450-0148 & 450-0152 modules contains the following information:

- LSR
- M/N: STERLING-LWB
- Part Number and Revision:
  - P/N: 450-0148 or 450-0152
  - R1 = Revision 1
- FCC ID: TFB-1003
- IC: 5969A-1003
- SSYYWWD = Date Code (SS=Manufacturer, YY=Year, WW=Week, D=Day)
- XXXXX = Incremental Serial Number
- 2D Barcode Format is Data Matrix Standard

**Rev 2 Devices**

- Updated the label to include Giteki marking information.



The shield on the 450-0148 & 450-0152 modules contains the following information:

- LSR
- M/N: STERLING-LWB
- Part Number and Revision:
  - P/N: 450-0148 or 450-0152
  - R2 = Revision 2
- FCC ID: TFB-1003
- IC: 5969A-1003
- SSYYWWD = Date Code (SS=Manufacturer, YY=Year, WW=Week, D=Day)
- XXXXX = Incremental Serial Number
- 2D Barcode Format is Data Matrix Standard



-  Giteki Logo
- Giteki Symbol of Radio Certification: R in the Square Box
- Giteki Certification Type Number: 209-J00212. 209 is the CAB ID assigned by the Minister of MIC. J00212 is the Certification Number assigned by the CAB.

**Rev 3 Devices**

- Updated the label to include RCM (C-Tick) marking information.



The shield on the 450-0148 & 450-0152 modules contains the following information:

- LSR
- M/N: STERLING-LWB
- Part Number and Revision:
  - P/N: 450-0148 or 450-0152
  - R3 = Revision 3
- FCC ID: TFB-1003
- IC: 5969A-1003
- SSYYWWD = Date Code (SS=Manufacturer, YY=Year, WW=Week, D=Day)
- XXXXX = Incremental Serial Number
- 2D Barcode Format is Data Matrix Standard



- Giteki Logo
- Giteki Symbol of Radio Certification: R in the Square Box
- Giteki Certification Type Number: 209-J00212. 209 is the CAB ID assigned by the Minister of MIC. J00212 is the Certification Number assigned by the CAB.



- RCM Logo (Australia/New Zealand Certification)
- <sup>TM</sup> = Trademark Logo

**Rev 4 Devices**

- Internal Update to MRP System



- All label information is the same as Rev 3

**CONTACTING LSR**

<b>Headquarters</b>	LS Research, LLC W66 N220 Commerce Court Cedarburg, WI 53012-2636 USA Tel: (262) 375-4400 Fax: (262) 375-4248
<b>Website</b>	<a href="http://www.lsr.com">www.lsr.com</a>
<b>Technical Support</b>	<a href="http://forum.lsr.com">forum.lsr.com</a>
<b>Sales Contact</b>	<a href="mailto:sales@lsr.com">sales@lsr.com</a>



© Copyright 2018 Laird. All Rights Reserved. Patent pending. Any information furnished by Laird and its agents is believed to be accurate and reliable. All specifications are subject to change without notice. Responsibility for the use and application of Laird materials or products rests with the end user since Laird and its agents cannot be aware of all potential uses. Laird makes no warranties as to non-infringement nor as to the fitness, merchantability, or sustainability of any Laird materials or products for any specific or general uses. Laird, Laird Technologies, Inc., or any of its affiliates or agents shall not be liable for incidental or consequential damages of any kind. All Laird products are sold pursuant to the Laird Terms and Conditions of Sale in effect from time to time, a copy of which will be furnished upon request. When used as a tradename herein, Laird means Laird Limited due to the acquisition by Advent or one or more subsidiaries of Laird Limited. Laird™, Laird Technologies™, corresponding logos, and other marks are trademarks or registered trademarks of Laird. Other marks may be the property of third parties. Nothing herein provides a license under any Laird or any third party intellectual property right.

---

The information in this document is subject to change without notice.

## Looking for pricing, stock, or lifecycle information?

Click below to explore more details on WIN SOURCE:

-  [View 450-0148R on WIN SOURCE](#)
-  [Laird Connectivity Inc. Information](#)

## Optimize Your Supply Chain with WIN SOURCE Solutions

-  Global Sourcing Solution
-  Obsolete Management
-  Cost Control Management
-  Shortage Management
-  Alternative Solution
-  Excess Inventory Management