



THE DATASHEET OF
30082



Element Kits – Part No's. 30082, 30083, 30084, 30085, 30086, 30087, 30088



Do not touch nozzle until cool



WARNING: Disconnect heat gun power cord and allow the heat gun to cool before disassembly.

READ THE SERVICE INSTRUCTIONS CAREFULLY. FAILURE TO EXACTLY FOLLOW THE INSTRUCTIONS COULD RESULT IN PERSONAL INJURY OR DAMAGE TO YOUR HEAT GUN. ALL REPAIRS MUST BE PERFORMED BY A QUALIFIED REPAIR TECHNICIAN.

TOOLS REQUIRED

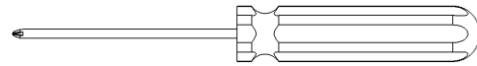

#2 DRIVE PHILLIPS SCREWDRIVER

If nozzle mounting screws (A) are lost or damaged, replace only with #6-32 steel machine screws, 3/16 inch minimum length to 1/2 inch maximum length.

THIS ELEMENT KIT CONSISTS OF:

- ELEMENT, (1)
- MICA INSULATOR, (1)
- RUBBER WASHER, (1)
- BRASS NUT, #2-56, (2)
- SCREW, PAN HEAD, #4-40, (1)

NOTE: Rubber Washer, Brass Nuts, and Screw are not used on model numbers listed above. They are required for older model heat guns shown on back side of this instruction sheet.

TO REMOVE OLD ELEMENT

1. Remove (2) nozzle mounting screws. (A)
2. Gently pull shield from gun housing.
3. Pull element out of housing.

TO INSTALL NEW ELEMENT

1. Gently insert new element into housing, with contacts of element inserted fully into spring contacts within housing. (B)
2. Wrap new mica insulator around coils of new element, ensuring all coils are covered.

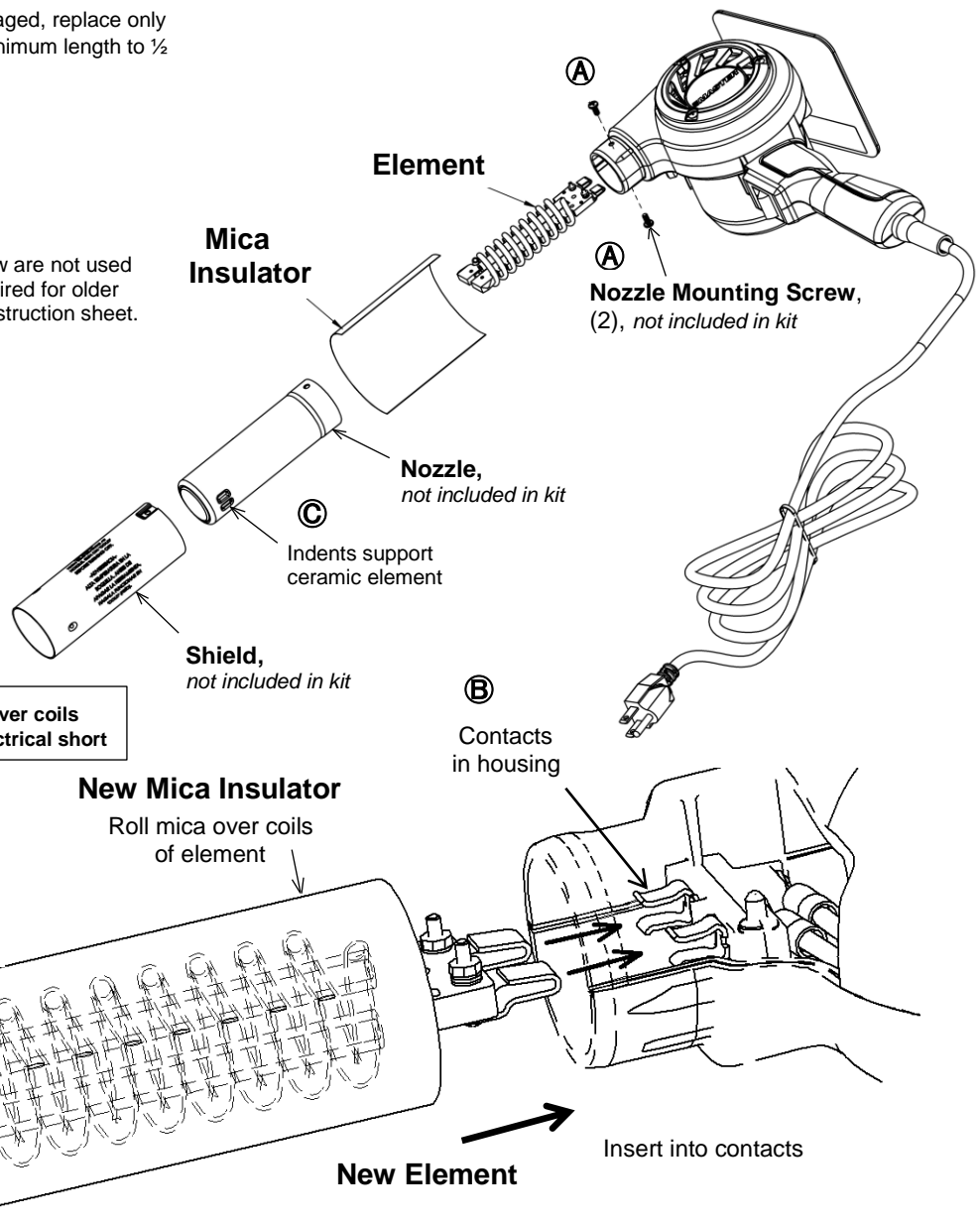

WARNING: Failure to properly cover coils with mica insulator could result in electrical short

3. Gently slide nozzle straight on, aligning ceramic element with front nozzle indents (C) and (2) nozzle screw holes. Slide shield over nozzle, aligning mounting holes. Install (2) nozzle mounting screws loosely until started, and then tighten. (A)

MASTER HEAT GUN REPLACEMENT PARTS AND ACCESSORIES ARE ENGINEERED AND MANUFACTURED TO PRECISE MASTER APPLIANCE SPECIFICATIONS. REPLACEMENT PARTS AND ACCESSORIES FROM OTHER MANUFACTURERS ARE NOT PRODUCED TO THESE PRECISE SPECIFICATIONS. FAILURE TO USE MASTER APPLIANCE REPLACEMENT PARTS OR FAILURE TO INSTALL MASTER APPLIANCE REPLACEMENT PARTS EXACTLY AS INSTRUCTED MAY CAUSE PHYSICAL INJURY OR DAMAGE TO THE HEAT GUN. MASTER APPLIANCE CANNOT ASSUME RESPONSIBILITY FOR PHYSICAL INJURY OR DAMAGE TO THE HEAT GUN RESULTING FROM THE USE OF ANY OTHER BRAND OF REPLACEMENT PART OR IMPROPER INSTALLATION OF MASTER APPLIANCE REPLACEMENT PARTS OR ACCESSORIES.

Element Kits – Part No's. 30082, 30083, 30084, 30085, 30086, 30087, 30088



WARNING: Disconnect heat gun power cord and allow the heat gun to cool before disassembly.

READ THE SERVICE INSTRUCTIONS CAREFULLY. FAILURE TO EXACTLY FOLLOW THE INSTRUCTIONS COULD RESULT IN PERSONAL INJURY OR DAMAGE TO YOUR HEAT GUN. ALL REPAIRS MUST BE PERFORMED BY A QUALIFIED REPAIR TECHNICIAN.

TOOLS REQUIRED

SLOTTED (FLAT) SCREWDRIVER



#1 PHILLIPS SCREWDRIVER



3/16" HEX WRENCH



Do not touch nozzle until cool

If nozzle mounting screws are lost or damaged, replace only with #6-40 steel machine screws, 3/16 inch minimum length to 1/4 inch maximum length.

THIS ELEMENT KIT CONSISTS OF:

- ELEMENT, (1)
- MICA INSULATOR, (1)
- RUBBER WASHER, (1)
- BRASS NUT, #2-56, (2)
- SCREW, PAN HEAD, #4-40, (1)

TO REMOVE OLD ELEMENT

1. Remove (3) nozzle mounting screws. **(A)**
2. Gently pull nozzle shield from gun housing.
3. Remove screws on housing, **(B)** and **(C)**, (NOTE: Models without the "A" or "B" suffix will not have the **(C)** screw.) Cover can now be lifted away.
4. Remove pan head screw and rubber washer holding element to housing, being careful that rubber washer does not fall back into the housing. **(D)**
5. Carefully lift element from its position exposing (2) element nuts holding wires to element. Remove nuts from element and disconnect wires. **(E)**

TO INSTALL NEW ELEMENT

1. Attach element lead wires with new brass nuts furnished in replacement kit. Make sure they are tight for good electrical connection. **(F)**
2. Mount new element with pan head screw and rubber washer. Rubber washer must be mounted between element and mounting boss on housing. Be sure not to overtighten. **(D)**
3. Gently press element lead wires down under blower wheel to prevent rubbing during operation.
4. Discard the old mica insulator sheets and replace with corrugated mica insulator supplied in kit. Wrap mica insulator around coils of element, ensuring all coils are covered and attach housing cover.



WARNING: Failure to properly cover coils with mica insulator could result in electrical short

5. Attach cover screws loosely. **(B)** & **(C)**
6. Gently slide nozzle straight on, aligning ceramic element with front nozzle indents and (3) rear nozzle screw holes. Slide nozzle shield over nozzle, lining up mounting holes. Install (3) mounting screws loosely until started and then tighten. Tighten cover screws. **(B)**

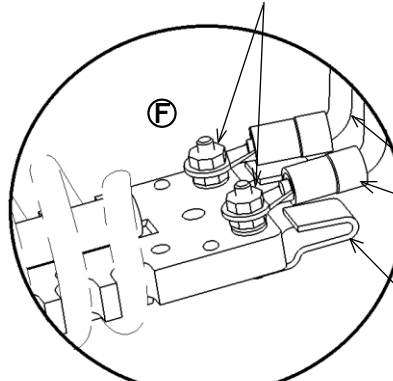
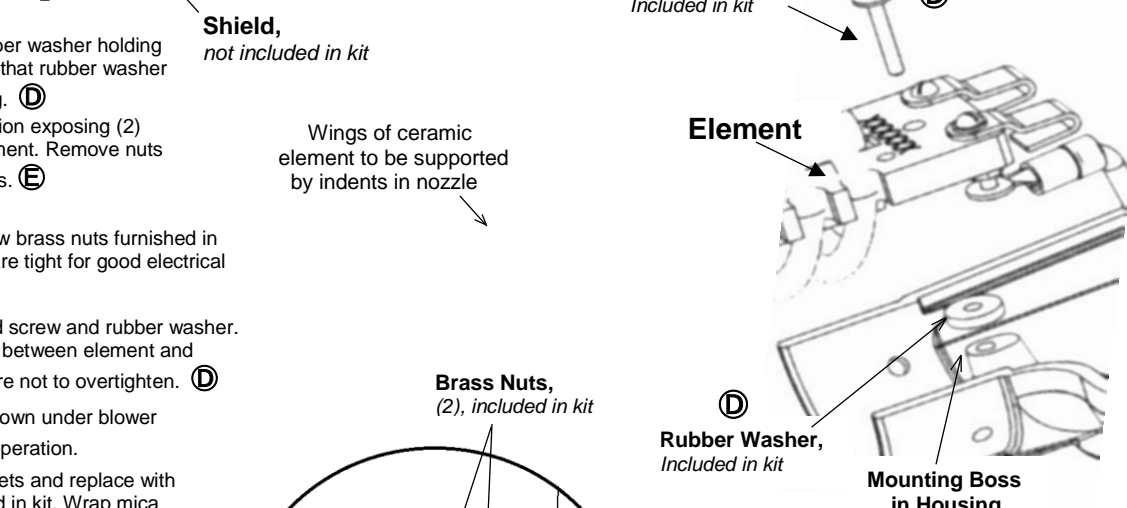
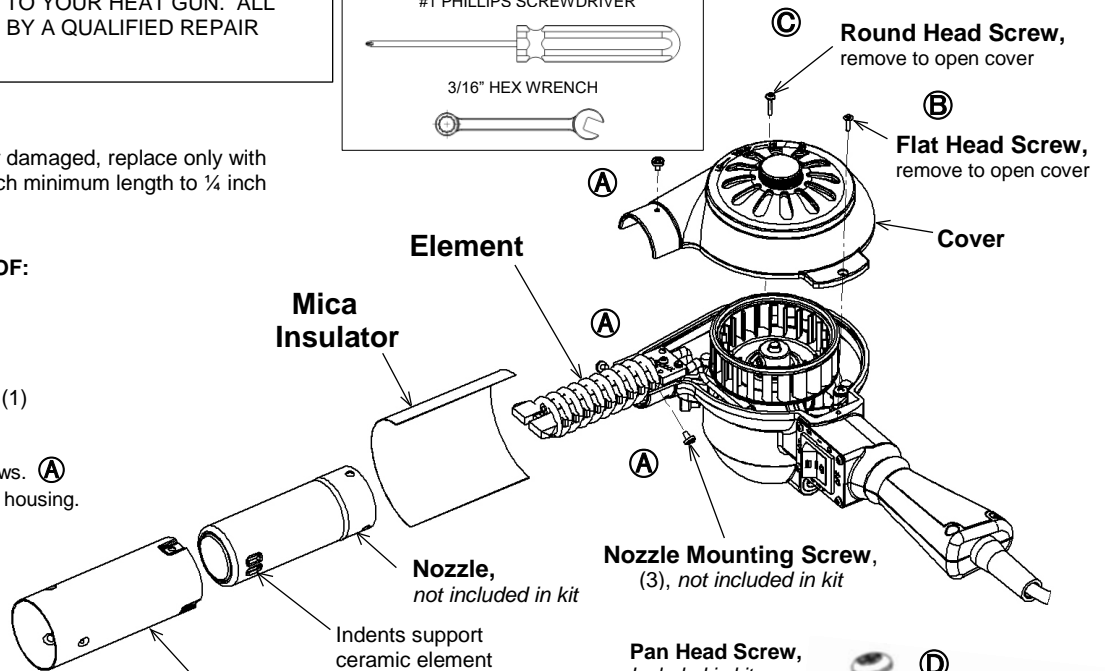

Looking for pricing, stock, or lifecycle information?

Click below to explore more details on WIN SOURCE:

-  [View 30082 on WIN SOURCE](#)
-  [Master Appliance Co](#) Information

Optimize Your Supply Chain with WIN SOURCE Solutions

-  Global Sourcing Solution
-  Obsolete Management
-  Cost Control Management
-  Shortage Management
-  Alternative Solution
-  Excess Inventory Management