



**THE DATASHEET OF  
2N7002KDW-HF**



## 2N7002KDW-HF

N-Channel  
RoHS Device  
Halogen Free

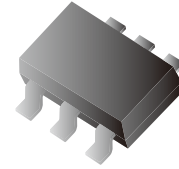

### Features

- High density cell design for low  $R_{DS(ON)}$ .
- Voltage controlled small signal switch.
- High saturation current capability.
- ESD protected.

### Mechanical data

- Case: SOT-363, molded plastic.
- Epoxy: UL 94V-0 flammability rating.

### Circuit Diagram

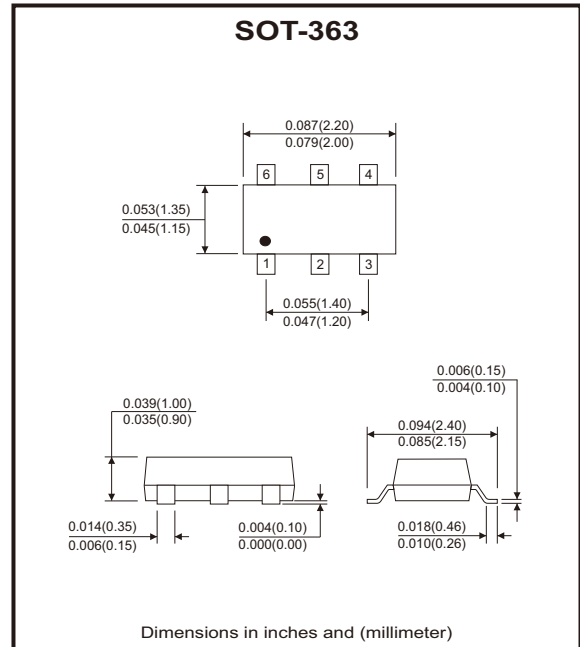
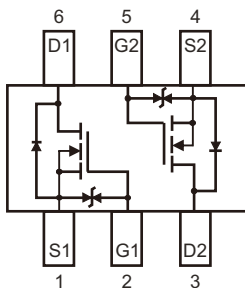

### Maximum Ratings (at $T_A=25^{\circ}C$ unless otherwise noted)

Parameter	Symbol	Value	Unit
Drain-Source voltage	$V_{DS}$	60	V
Gate-Source voltage	$V_{GS}$	$\pm 20$	V
Drain current	$I_D$	340	mA
Total power dissipation	$P_D$	150	mW
Thermal resistance from junction to ambient	$R_{\theta JA}$	820	$^{\circ}C/W$
Junction temperature	$T_J$	150	$^{\circ}C$
Storage temperature range	$T_{STG}$	-55 to +150	$^{\circ}C$

## Electrical Characteristics (at T<sub>A</sub>=25°C unless otherwise noted)

Parameter	Conditions	Symbol	Min	Typ	Max	Unit
<b>Static Characteristics</b>						
Drain-Source breakdown voltage	V <sub>GS</sub> = 0V, I <sub>D</sub> = 250μA	V <sub>(BR)DSS</sub>	60			V
Gate-Threshold voltage (Note 1)	V <sub>DS</sub> = V <sub>GS</sub> , I <sub>D</sub> = 1mA	V <sub>GS(th)</sub>	1		2.5	V
Gate-body leakage	V <sub>DS</sub> = 0V, V <sub>GS</sub> = ±20V	I <sub>GSS</sub>			±10	μA
Zero gate voltage drain current	V <sub>DS</sub> = 48V, V <sub>GS</sub> = 0V	I <sub>DSS</sub>			1	μA
Drain-Source on-resistance (Note 1)	V <sub>GS</sub> = 4.5V, I <sub>D</sub> = 200mA	R <sub>DS(ON)</sub>			5.3	Ω
	V <sub>GS</sub> = 10V, I <sub>D</sub> = 500mA				5	
Diode forward voltage (Note 1)	V <sub>GS</sub> = 0V, I <sub>S</sub> = 300mA	V <sub>SD</sub>			1.5	V
Recovered charge	V <sub>GS</sub> = 0V, I <sub>S</sub> = 300mA, V <sub>R</sub> = 25V dI <sub>S</sub> /dt = -100A/μs	Q <sub>r</sub>		30		nC
<b>Dynamic Characteristics</b>						
Input capacitance	V <sub>DS</sub> = 10V, V <sub>GS</sub> = 0V, f = 1MHz	C <sub>iss</sub>			40	pF
Output capacitance		C <sub>oss</sub>			30	pF
Reverse transfer capacitance		C <sub>rss</sub>			10	pF
<b>Switching Characteristics</b>						
Turn-on delay time	V <sub>DD</sub> = 50V, V <sub>GS</sub> = 10V, R <sub>L</sub> = 250Ω	t <sub>d(on)</sub>			10	ns
Turn-off delay time	R <sub>GS</sub> = 50Ω, R <sub>GEN</sub> = 50Ω	t <sub>d(off)</sub>			15	ns
Reverse recovery time	V <sub>GS</sub> = 0V, I <sub>S</sub> = 300mA, V <sub>R</sub> = 25V dI <sub>S</sub> /dt = -100A/μs	t <sub>rr</sub>		30		ns
<b>Gate-Source Zener Diode</b>						
Gate-Source breakdown voltage	I <sub>GS</sub> = ±1mA (open drain)	BV <sub>GSO</sub>	±21.5		±30	V

Notes: 1. Pulse test: Pulse width ≤ 300μs, duty cycle ≤ 2%.

## Rating and Characteristic Curves (2N7002KDW-HF)

Fig.1 - Output Characteristics

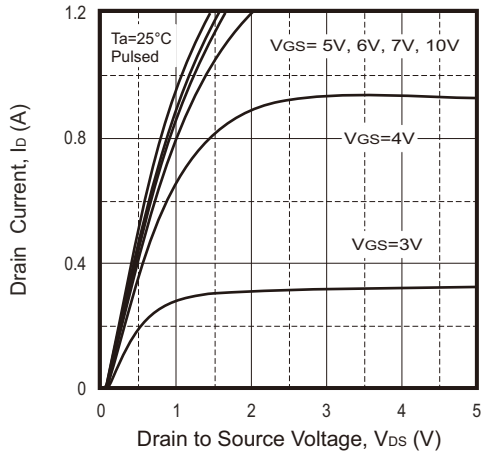

Fig.2 - Transfer Characteristics

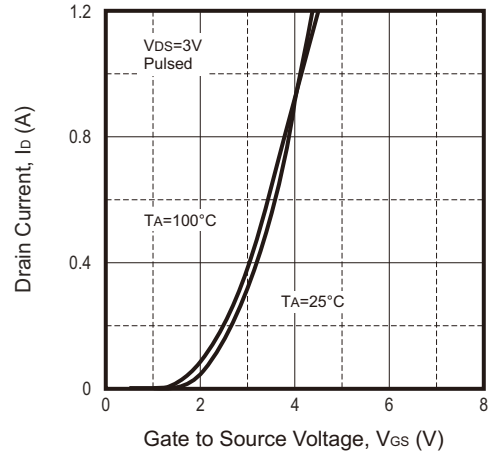

Fig.3 -  $R_{DS(ON)} - I_D$

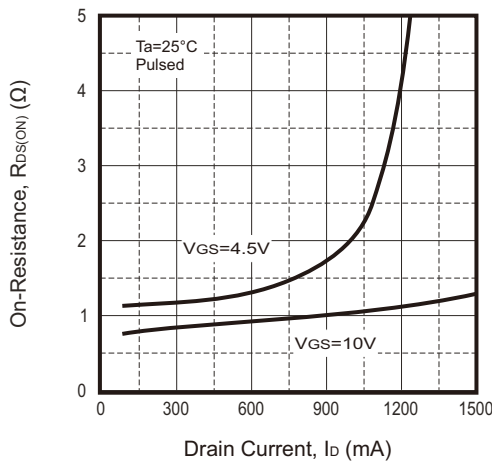

Fig.4 -  $R_{DS(ON)} - V_{GS}$

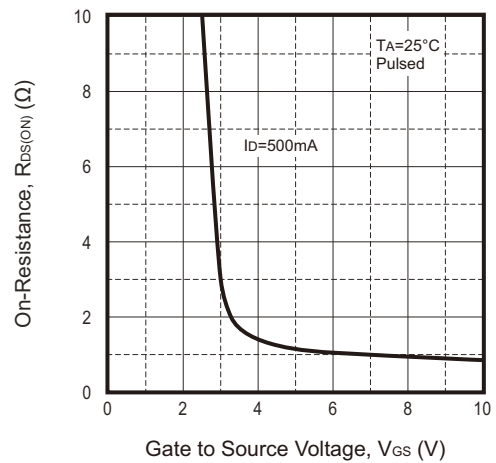

Fig.5 -  $I_S - V_{SD}$

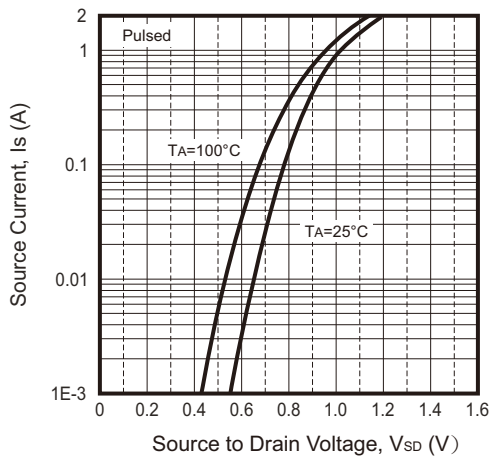
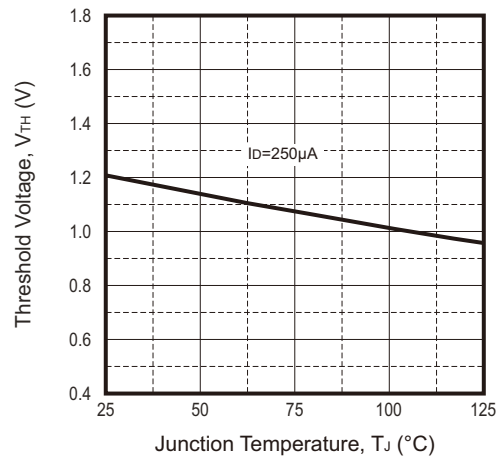
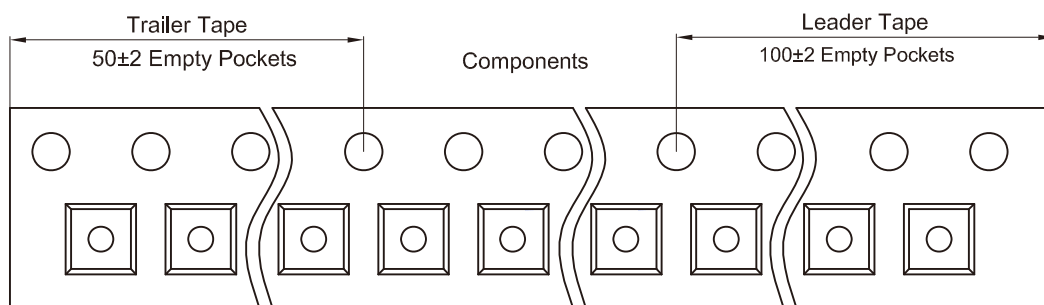
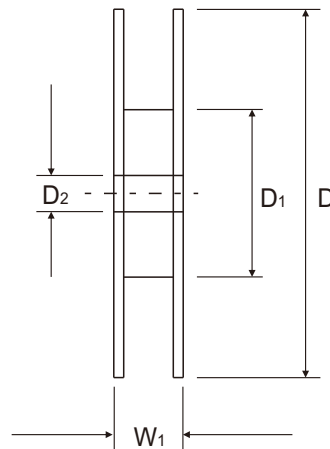
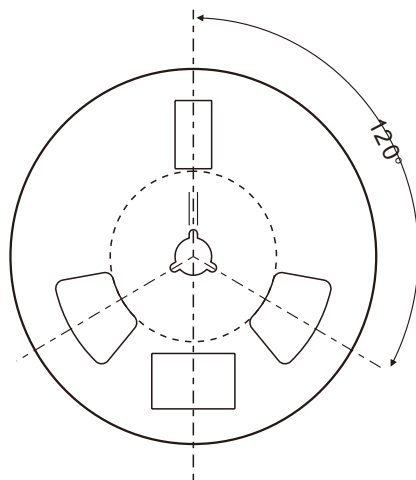
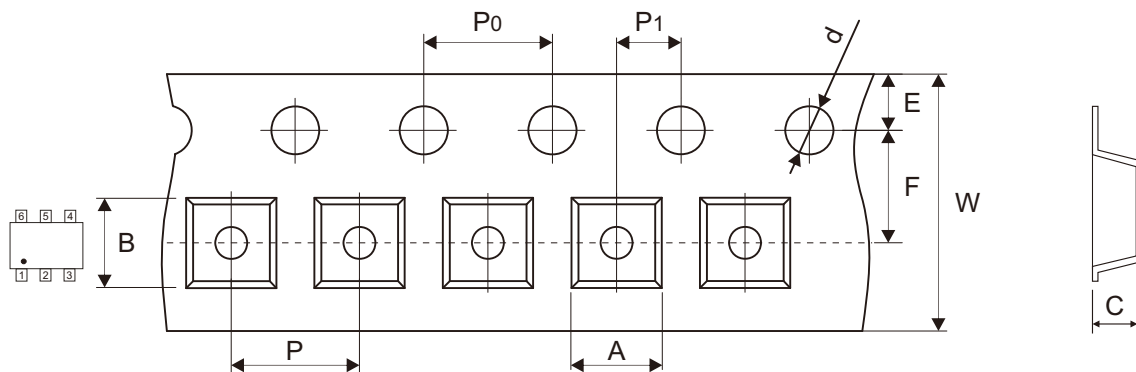

Fig.6 - Threshold Voltage



Company reserves the right to improve product design, functions and reliability without notice.

## Reel Taping Specification



SOT-363	SYMBOL	A	B	C	d	D	D1	D2
	(mm)	2.40 ± 0.10	2.55 ± 0.10	1.20 ± 0.10	1.50 ± 0.10	178.00 ± 1.00	54.40 ± 0.50	13.00 ± 0.20
	(inch)	0.094 ± 0.004	0.100 ± 0.004	0.047 ± 0.004	0.059 ± 0.004	7.008 ± 0.039	2.142 ± 0.020	0.512 ± 0.008

SOT-363	SYMBOL	E	F	P	P0	P1	W	W1
	(mm)	1.75 ± 0.10	3.50 ± 0.05	4.00 ± 0.10	4.00 ± 0.10	2.00 ± 0.05	8.00 + 0.30 - 0.10	13.10 ± 1.30
	(inch)	0.069 ± 0.004	0.138 ± 0.002	0.157 ± 0.004	0.157 ± 0.004	0.079 ± 0.002	0.315 + 0.012 - 0.004	0.516 ± 0.051

Company reserves the right to improve product design, functions and reliability without notice.

REV:A

## Marking Code

Part Number	Marking Code
2N7002KDW-HF	72K

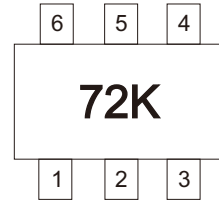

## Suggested PAD Layout

SIZE	SOT-363	
	(mm)	(inch)
A	0.40	0.016
B	0.816	0.032
C	0.65	0.026
D	1.94	0.076

Note: 1. The pad layout is for reference purposes only.

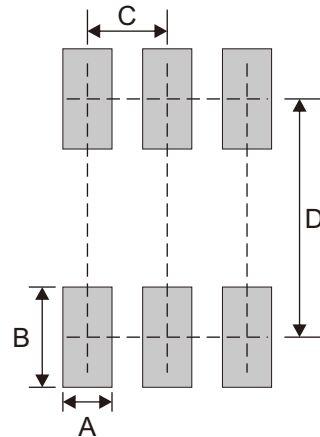

## Standard Packaging

Case Type	REEL PACK	
	REEL ( pcs )	Reel Size (inch)
SOT-363	3,000	7

## Looking for pricing, stock, or lifecycle information?

Click below to explore more details on WIN SOURCE:

- [View 2N7002KDW-HF on WIN SOURCE](#)
- [Comchip Technology Information](#)

## Optimize Your Supply Chain with WIN SOURCE Solutions

- ✓ Global Sourcing Solution
- ✓ Obsolete Management
- ✓ Cost Control Management
- ✓ Shortage Management
- ✓ Alternative Solution
- ✓ Excess Inventory Management