



**THE DATASHEET OF  
145806010002829+**



0.4mm Pitch  
Board to Board Connector

# 5806 Series

シリーズ (Series)	5806
基板間高さ (Stacking Height)	0.6mm
極間隔 (Pitch)	0.4mm
極数 (No. of Positions)	10 to 60 Pos.
定格電流 (Rated Current)	DC 0.3A/Contact
定格電圧 (Rated Voltage)	DC 50V/Contact
耐電圧 (D. W. Voltage)	AC 250Vrms/min.
コンタクト材質 (Contact Material)	銅合金 (Copper alloy)
インシュレータ材質 (Insulator Material)	耐熱樹脂 (Heat-resistant plastic)
使用温度範囲 (Operating Temperature)	-40 to +85°C

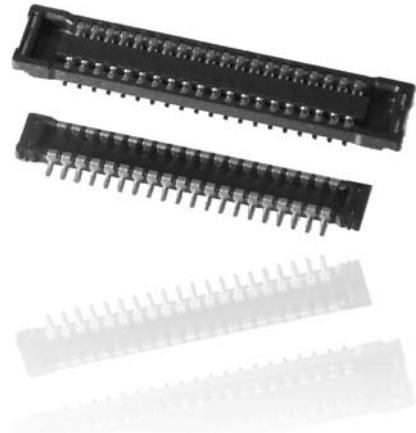

#### ◆概要

5806 シリーズは、0.4mm ピッチ、嵌合（基板間）高さ 0.6mm の狭ピッチ・超低背の基板対基板用コネクタで、奥行き（短手方向）寸法 1.9mm を実現し、機器の省スペース化とスリム化に貢献する製品です。

省スペースを実現しながらも、独自のロック構造による優れたクリック感と保持力を強化し、また基板との剥離強度も固定金具により強化しています。さらに、接点部には「挟み込み接点形状」を採用し、振動や落下衝撃にも強い構造で、高い接触信頼性を実現しています。

#### ◆特長

- (1) 0.4mm ピッチ、基板間（嵌合）高さ 0.6mm、奥行き寸法 1.9mm、の省スペース型コネクタで、機器の省スペース化に貢献します。
- (2) 嵌合時のロック構造は、弊社独自のロック構造を採用。超低背でありながらも優れたクリック感と、抜去時の保持力を強化しています。
- (3) 接点部は、「挟み込み接点形状」（2点接点）を採用し、振動や落下衝撃などに強い構造となっています。また、プラグコンタクトの形状は、集中荷重を上げて異物を排除（ワイピング効果）する機構を施し、高い接触信頼性を実現しています。
- (4) 5,000 個入りのエンボステープ梱包でお届けします。
- (5) 環境に優しい RoHS 指令対応品です。

#### ◆Outline

The 5806 Series are Board to Board Connectors with a fine pitch of 0.4mm and an ultra-low stacking height of 0.6mm (between boards). These products feature the width of 1.9mm on the short side, which contributes to downsizing in small electronic equipment. An original locking structure generates a firm 'click' sound and enhances the retention force despite the slim and low profile, and peeling strength against printed circuit boards is strengthened by equipping metal tabs. In addition, a pinching structure (two-point contact design) has been adopted to enhance resistance to vibrations and drop shocks, thus ensuring high contact reliability.

#### ◆Features

- (1) Space-saving connector with a stacking height of 0.6mm and width of 1.9mm, which contributes to downsizing in small electronic equipment.
- (2) An original locking structure is adopted for mating, which generates a firm 'click' sound and enhances the retention force when connectors are removed despite the ultra-low profile.
- (3) A pinching structure (two-point contact design) is adopted to enhance resistance to vibrations and drop shocks. In addition, the plug connector features a structure which removes foreign matter with concentrated load (wiping effect), thus realizing high contact reliability.
- (4) Packaged in tape and reel: 5,000 pieces/reel.
- (5) RoHS compliant product.

本カタログには推奨めっきを掲載しております。めっき種類・仕様、ならびに生産対応可能極数については営業部にご確認願います。

Recommended plating types are mentioned in this catalogue. For other plating types and their specifications, and available numbers of positions, please feel free to contact our sales department.

# 0.4mm Pitch 5806 Series

0.4mmピッチ 嵌合高さ0.6mm 金具付き SMT  
0.4mm Pitch, Stacking Height=0.6mm, With Metal tabs, SMT

## ● Plug

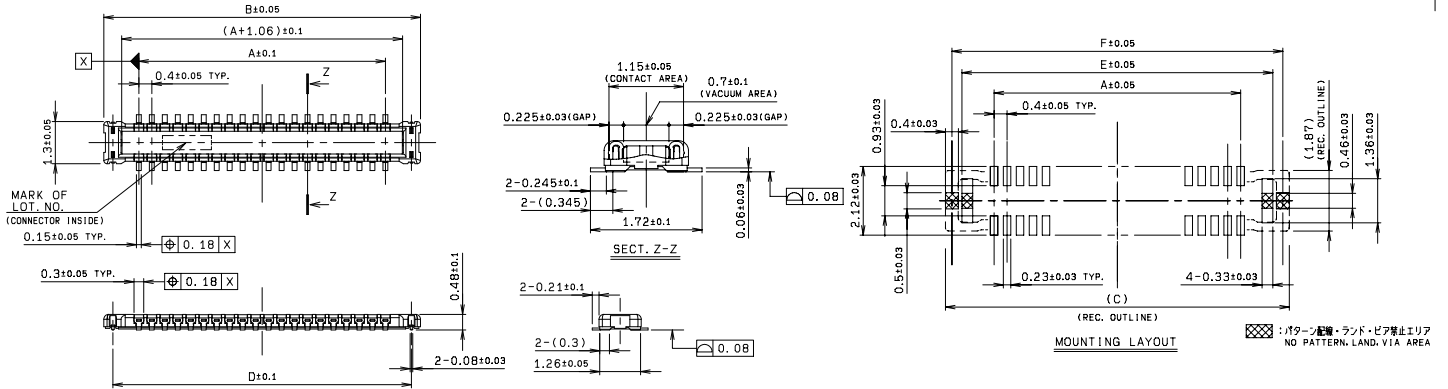

## ● Receptacle

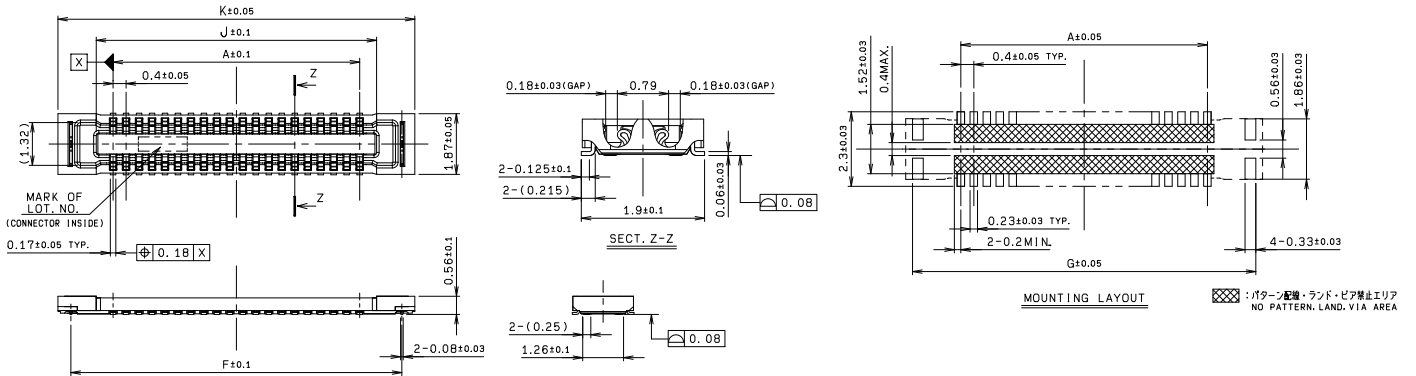

## ● Packaging

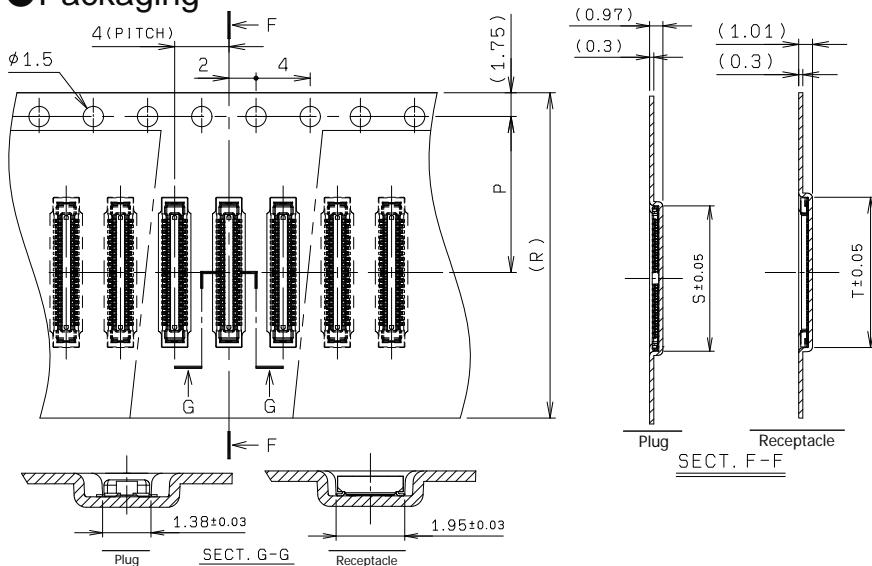

極数 NO. OF POS.	A	B	C	D	E	F	G	J	K
10	1.6	3.76	5.0	3.2	3.58	4.2	4.58	2.64	5.0
12	2.0	4.16	5.4	3.6	3.98	4.6	4.98	3.04	5.4
14	2.4	4.56	5.8	4.0	4.38	5.0	5.38	3.44	5.8
16	2.8	4.96	6.2	4.4	4.78	5.4	5.78	3.84	6.2
18	3.2	5.36	6.6	4.8	5.18	5.8	6.18	4.24	6.6
20	3.6	5.76	7.0	5.2	5.58	6.2	6.58	4.64	7.0
22	4.0	6.16	7.4	5.6	5.98	6.6	6.98	5.04	7.4
24	4.4	6.56	7.8	6.0	6.38	7.0	7.38	5.44	7.8
26	4.8	6.96	8.2	6.4	6.78	7.4	7.78	5.84	8.2
30	5.6	7.76	9.0	7.2	7.58	8.2	8.58	6.64	9.0
32	6.0	8.16	9.4	7.6	7.98	8.6	8.98	7.04	9.4
34	6.4	8.56	9.8	8.0	8.38	9.0	9.38	7.44	9.8
40	7.6	9.76	11.0	9.2	9.58	10.2	10.58	8.64	11.0
44	8.4	10.56	11.8	10.0	10.38	11.0	11.38	9.44	11.8
50	9.6	11.76	13.0	11.2	11.58	12.2	12.58	10.64	13.0
54	10.4	12.56	13.8	12.0	12.38	13.0	13.38	11.44	13.8
60	11.6	13.76	15.0	13.2	13.58	14.2	14.58	12.64	15.0

極数 NO. OF POS.	P	R	S	T
10	5.5	12.0	3.84	5.08
12	5.5	12.0	4.24	5.48
14	7.5	16.0	4.64	5.88
16	7.5	16.0	5.04	6.28
18	7.5	16.0	5.44	6.68
20	7.5	16.0	5.84	7.08
22	7.5	16.0	6.24	7.48
24	7.5	16.0	6.64	7.88
26	7.5	16.0	7.04	8.28
30	7.5	16.0	7.84	9.08
32	7.5	16.0	8.24	9.48
34	11.5	24.0	8.64	9.88
40	11.5	24.0	9.84	11.08
44	11.5	24.0	10.64	11.88
50	11.5	24.0	11.84	13.08
54	11.5	24.0	12.64	13.88
60	11.5	24.0	13.84	15.08

### 注文コード/Ordering Code

Plug  
Part No. 14 5806 OXX 002 829+  
極数 No. of Pos.

Receptacle  
Part No. 24 5806 OXX 112 829+  
極数 No. of Pos.

RoHS 対応品  
RoHS Compliant Product

梱包数量: 5,000個/リール  
PACKING QUANTITY: 5,000/Reel

本カタログには推奨めっきを掲載しております。めっき種類・仕様、ならびに生産対応可能極数については営業部にご確認願います。  
Recommended plating types are mentioned in this catalogue. For other plating types and their specifications, and available numbers of positions, please feel free to contact our sales department.

## Looking for pricing, stock, or lifecycle information?

Click below to explore more details on WIN SOURCE:

- [View 145806010002829+ on WIN SOURCE](#)
- [AVX Corp/Kyocera Corp Information](#)

## Optimize Your Supply Chain with WIN SOURCE Solutions

- ✓ Global Sourcing Solution
- ✓ Obsolete Management
- ✓ Cost Control Management
- ✓ Shortage Management
- ✓ Alternative Solution
- ✓ Excess Inventory Management