



# THE DATASHEET OF M2B



## Double-Balanced Mixer

Rev. V5

### Features

- LO & RF: 10 TO 1600 MHz
- IF: DC TO 800 MHz
- LO DRIVE: +13 dBm (NOMINAL)
- HIGH ISOLATION: 40 dB (TYP.)

### Description

The M2B is a double balanced mixer, designed for use in military, commercial, and test equipment applications. The design utilizes Schottky ring quad diodes and broadband ferrite baluns to attain excellent performance. This mixer can also be used as a phase detector and/or bi-phase modulator since the IF port is DC coupled to the diodes. Environmental screening is available to MIL-STD-883, MIL-STD-202, or MIL-DTL-28837, consult factory.

### Product Image

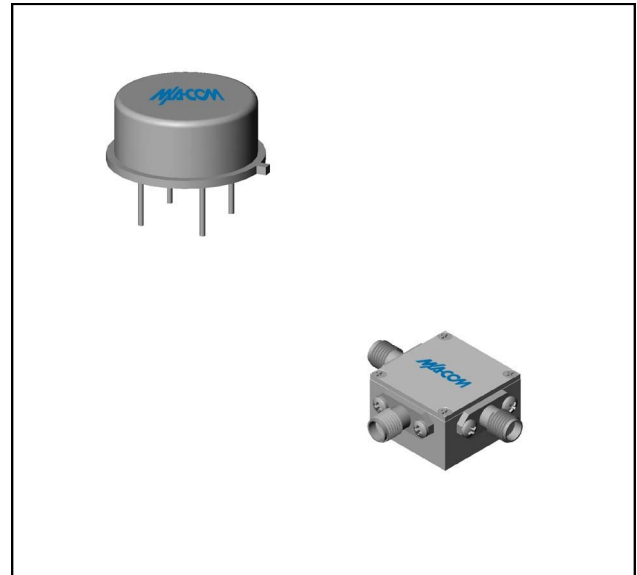

### Ordering Information

Part Number	Package
M2B	TO-8
M2BC	SMA Connectorized

### Electrical Specifications: $Z_0 = 50\Omega$ $L_o = +13$ dBm (Downconverter application only)

Parameter	Test Conditions	Units	Typical	Guaranteed	
				+25°C	-54° to +85°C *
SSB Conversion Loss (max) & SSB Noise Figure (max)	fR = 0.02 to 0.6 GHz, fL = 0.01 to 0.8 GHz, fl = 0.0004 to 0.2 GHz fR = 0.01 to 1.6 GHz, fL = 0.01 to 1.6 GHz, fl = 0.0004 to 0.8 GHz	dB	7.0	8.0	8.5
			8.0	9.0	9.5
Isolation, L to R (min)	fL = 0.01 to 0.7 GHz	dB	50	40	38
	fL = 0.7 to 1.2 GHz	dB	45	30	28
	fL = 1.2 to 1.6 GHz	dB	35	25	23
Isolation, L to I (min)	fL = 0.01 to 0.7 GHz	dB	40	30	28
	fL = 0.7 to 1.2 GHz	dB	30	20	18
	fL = 1.2 to 1.6 GHz	dB	25	18	16
1 dB Conversion Comp.	fL = +13 dBm	dBm	+7		
Input IP3		dBm	+22		

1 \* The M2BC specification limits apply at 0°C to +50°C.

### Typical Performance Curves

**Conversion Loss**

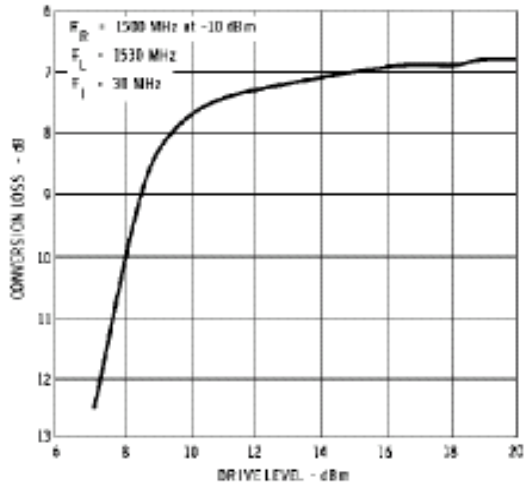

**Isolation**

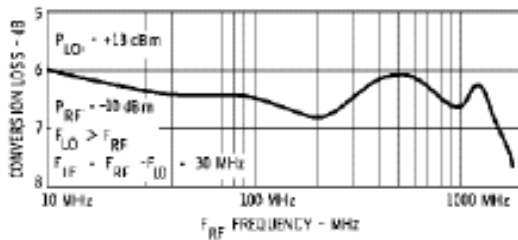
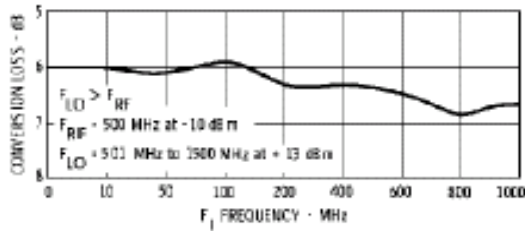
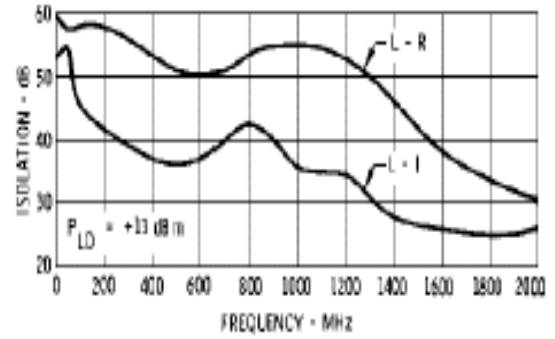

## Double-Balanced Mixer

Rev. V5

### Absolute Maximum Ratings

Parameter	Absolute Maximum
Operating Temperature	-54°C to +100°C
Storage Temperature	-65°C to +100°C
Peak Input Power	+23 dBm max @ +25°C +17 dBm max @ +100°C
Peak Input Current	50 mA DC

### Outline Drawing: TO-8 \*

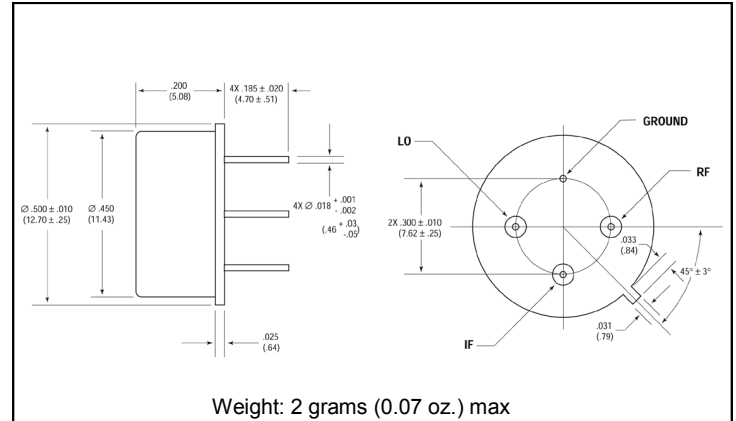

### Outline Drawing: SMA Connectorized \*

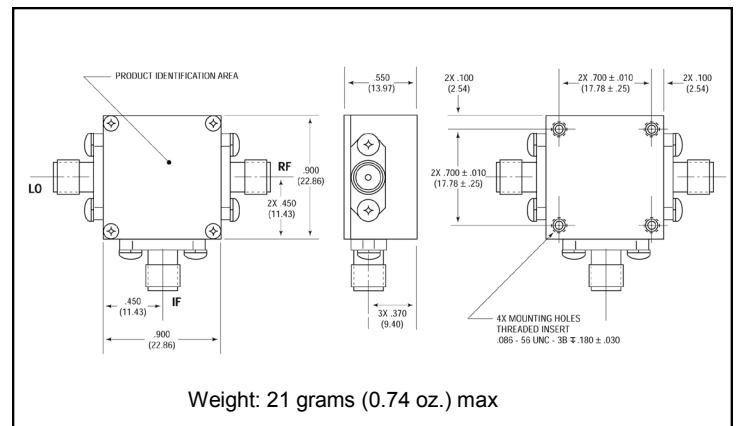

\* Dimensions are inches (millimeters) ±0.015 (0.38) unless otherwise specified.

M/A-COM Technology Solutions Inc. All rights reserved.

Information in this document is provided in connection with M/A-COM Technology Solutions Inc ("MACOM") products. These materials are provided by MACOM as a service to its customers and may be used for informational purposes only. Except as provided in MACOM's Terms and Conditions of Sale for such products or in any separate agreement related to this document, MACOM assumes no liability whatsoever. MACOM assumes no responsibility for errors or omissions in these materials. MACOM may make changes to specifications and product descriptions at any time, without notice. MACOM makes no commitment to update the information and shall have no responsibility whatsoever for conflicts or incompatibilities arising from future changes to its specifications and product descriptions. No license, express or implied, by estoppel or otherwise, to any intellectual property rights is granted by this document.

THESE MATERIALS ARE PROVIDED "AS IS" WITHOUT WARRANTY OF ANY KIND, EITHER EXPRESS OR IMPLIED, RELATING TO SALE AND/OR USE OF MACOM PRODUCTS INCLUDING LIABILITY OR WARRANTIES RELATING TO FITNESS FOR A PARTICULAR PURPOSE, CONSEQUENTIAL OR INCIDENTAL DAMAGES, MERCHANTABILITY, OR INFRINGEMENT OF ANY PATENT, COPYRIGHT OR OTHER INTELLECTUAL PROPERTY RIGHT. MACOM FURTHER DOES NOT WARRANT THE ACCURACY OR COMPLETENESS OF THE INFORMATION, TEXT, GRAPHICS OR OTHER ITEMS CONTAINED WITHIN THESE MATERIALS. MACOM SHALL NOT BE LIABLE FOR ANY SPECIAL, INDIRECT, INCIDENTAL, OR CONSEQUENTIAL DAMAGES, INCLUDING WITHOUT LIMITATION, LOST REVENUES OR LOST PROFITS, WHICH MAY RESULT FROM THE USE OF THESE MATERIALS.

MACOM products are not intended for use in medical, lifesaving or life sustaining applications. MACOM customers using or selling MACOM products for use in such applications do so at their own risk and agree to fully indemnify MACOM for any damages resulting from such improper use or sale.

## Looking for pricing, stock, or lifecycle information?

Click below to explore more details on WIN SOURCE:

- ⊖ [View M2B on WIN SOURCE](#)
- ⊖ [M/A-Com Technology Solutions](#) Information

## Optimize Your Supply Chain with WIN SOURCE Solutions

- ✓ Global Sourcing Solution
- ✓ Obsolete Management
- ✓ Cost Control Management
- ✓ Shortage Management
- ✓ Alternative Solution
- ✓ Excess Inventory Management