

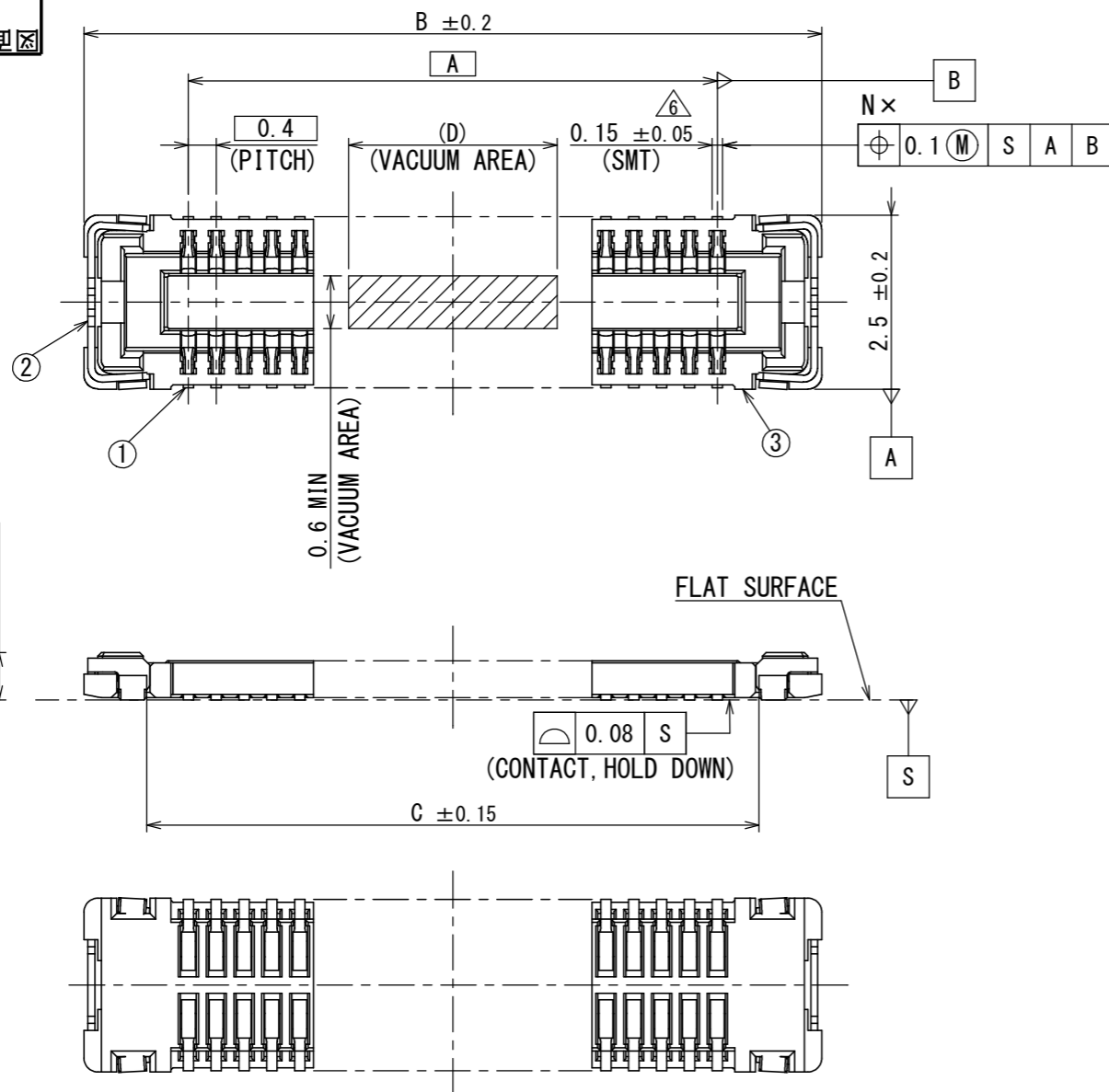

**THE DATASHEET OF  
WP7A-S026VA1-R6000**



SJ111875  
(ON DRAWING) (台異図)



版数 VER.	年月日 DATE	CN NO.	変更内容 DESCRIPTION	製図 DR.	担当 CHK.	査閲 APPD.	承認 APPD.
2	28/FEB/2012	001773	ADDED ITEM.	—	T. KOBUCHI	T. NISHIMURA	H. OBIKANE
3	02/NOV/2012	004406	ADDED ITEM.	—	H. MATSUZAKI	T. NISHIMURA	H. OBIKANE
4	28/FEB/2013	005530	ADDED ITEM.	—	H. MATSUZAKI	T. NISHIMURA	H. OBIKANE
5	29/MAR/2013	005869	ADDED ITEM.	—	H. MATSUZAKI	T. NISHIMURA	H. OBIKANE
6	03/APR/2013	005908	CORRECT AN ERROR	—	H. MATSUZAKI	T. NISHIMURA	H. OBIKANE

TABLE 1

DIMENSIONS 寸法	NUMBER OF CONTACT 芯数			
	A	B	C	D
10	1.6	4.6	2.8	2.0
16	2.8	5.8	4.0	2.0
20	3.6	6.6	4.8	2.0
22	4.0	7.0	5.2	2.0
24	4.4	7.4	5.6	2.0
26	4.8	7.8	6.0	5.0
28	5.2	8.2	6.4	5.0
30	5.6	8.6	6.8	5.0
32	6.0	9.0	7.2	5.0

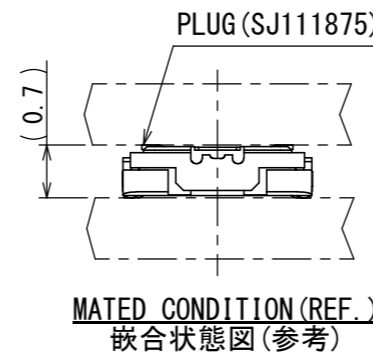

NOTE 1. IT SHOULD BE 3.5 ± 0.05 IF REPAIRING IS NEEDED.  
注 1. リペアーが必要な場合、この寸法は3.5 ± 0.05を推奨する。

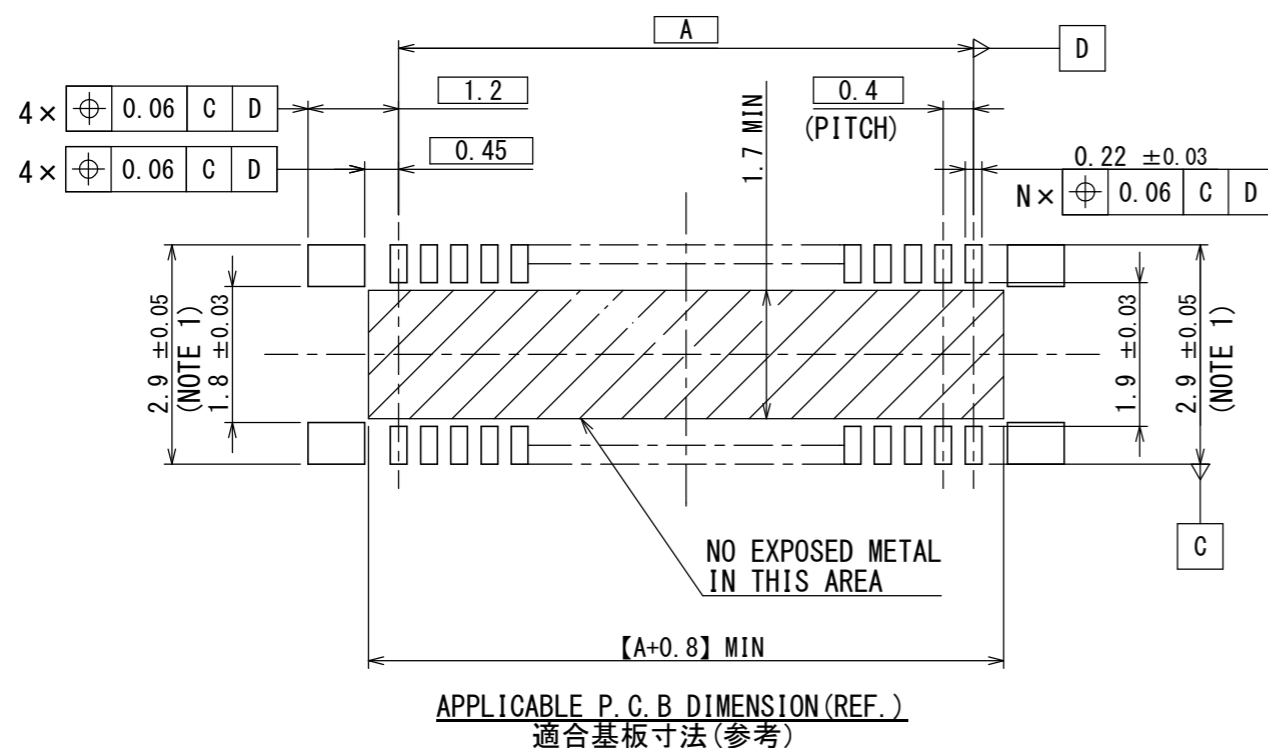

符号 NO.	名称 DESCRIPTION	個数 QTY.	材料 MATERIAL	仕上 FINISH	備考 REMARKS
3	INSULATOR インシュレータ	1	HEAT RESISTING PLASTICS 耐熱プラスチック	—	—
2	HOLD DOWN ホールドダウン	2	COPPER ALLOY 銅合金	TIN PLATING Snめっき	—
1	CONTACT コンタクト	N	COPPER ALLOY 銅合金	GOLD PLATING OVER NICKEL Ni上Auめっき	CONTACT AREA : GOLD (0.1 μm MIN) TERMINAL AREA : GOLD (0.05 μm MIN)

仕様書 (SPECIFICATION) JACS-10814	第1版 (ORIGINAL DATE) 16/JUN/2011	尺度 (SCALE) 10:1	シリーズ (SERIES) WP7A	日本航空電子工業株式会社
一般公差 (GENERAL TOLERANCE)	製図 DR.	名称 (TITLE) WP7A-S***VA1		JAE JAPAN AVIATION ELECTRONICS INDUSTRY, LTD.
寸法 (DIMENSION)	担当 CHK. H. MATSUZAKI	質量 (MASS)		
角度 (ANGLES)	査閲 APPD. T. NISHIMURA	承認 APPD. H. OBIKANE		図面番号 (DRAWING NO.) SJ111877
単位 (UNIT) : mm	質量 (MASS)			版数 (VER.) 6

DCF-C-212H(12.08)

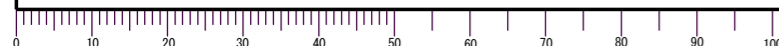

WISDOM承認 2013/04/03

690811CS  
DRAWING NO. (ON DRAWING) 台異異図

版数 VER.	年月日 DATE	CN NO.	変更内容 DESCRIPTION	製図 DR.	担当 CHK.	査閲 APPD.	承認 APPD.
------------	-------------	--------	---------------------	-----------	------------	-------------	-------------

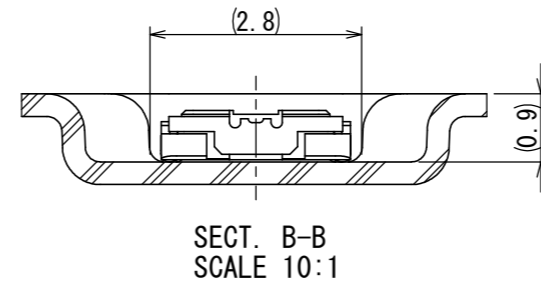
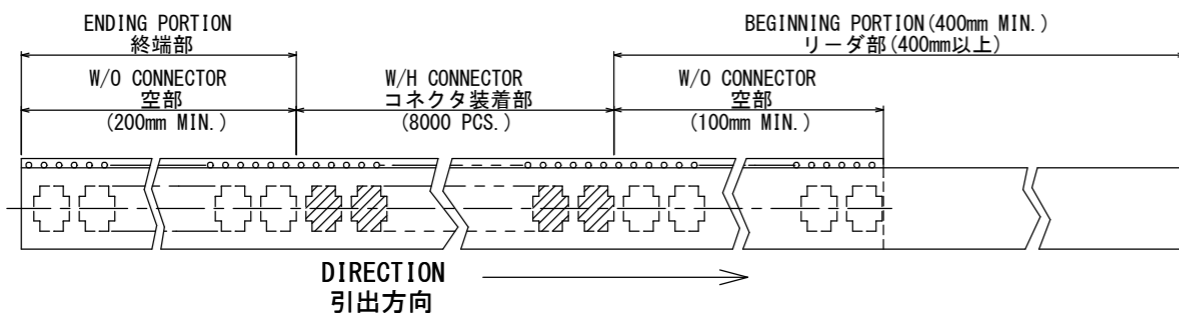
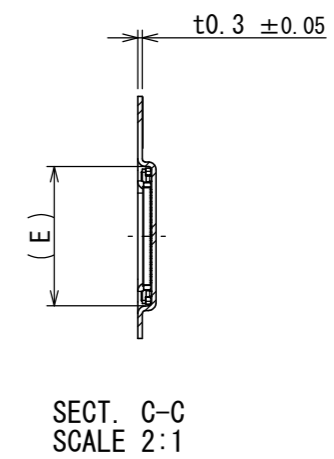
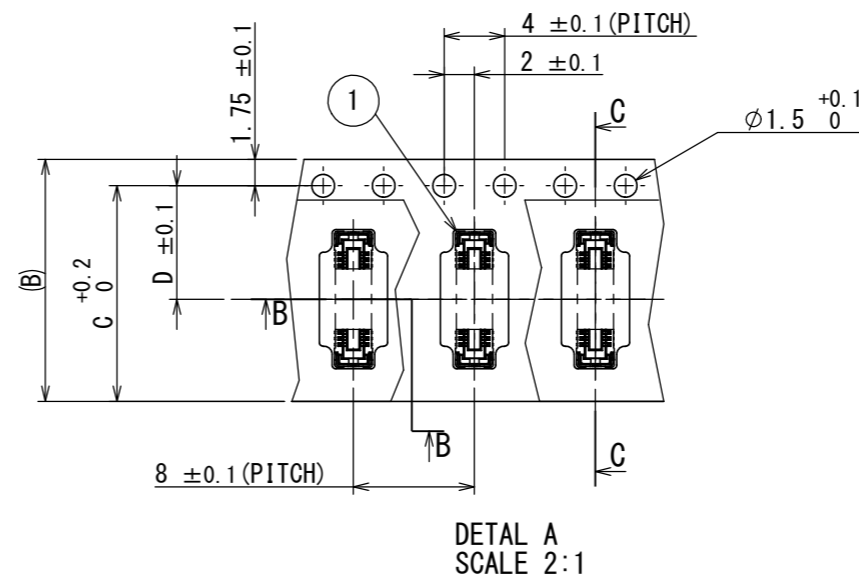
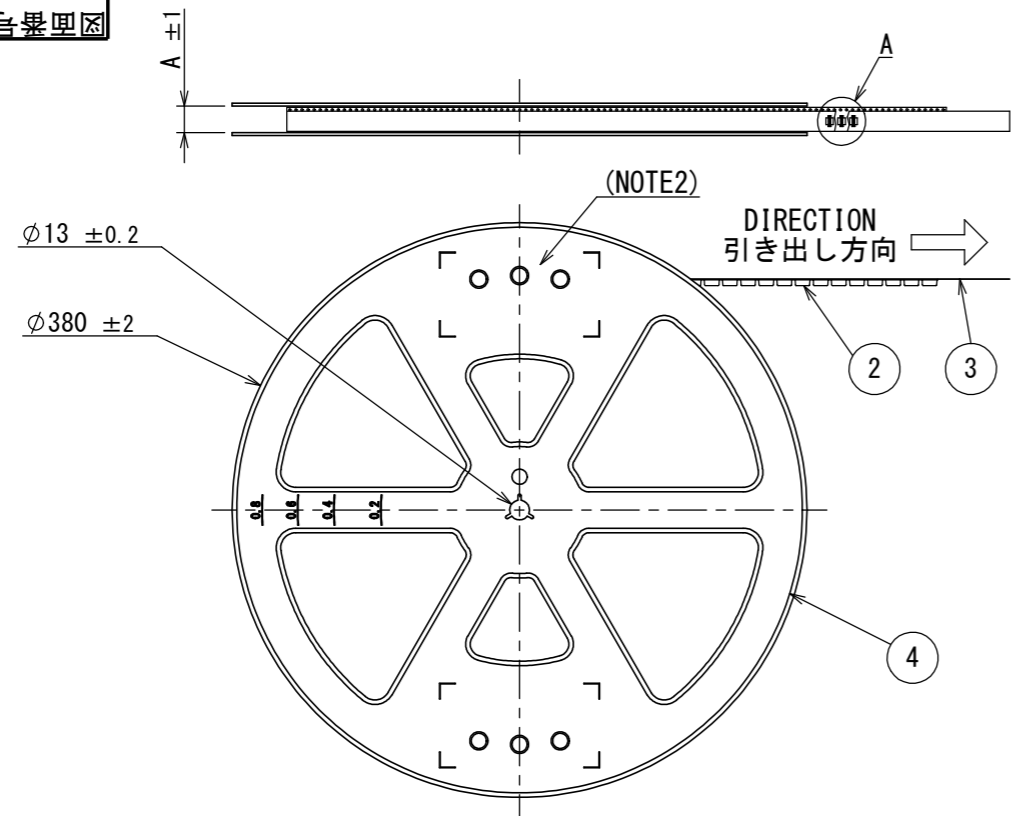

TABLE 1

DIMENSIONS 寸法	NUMBER OF CONTACTS 芯数				
	A	B	C	D	E
10	17.4	12.0	10.25	5.5	4.8
16	21.4	16.0	14.25	7.5	6.0
20	21.4	16.0	14.25	7.5	6.8
22	21.4	16.0	14.25	7.5	7.2
24	21.4	16.0	14.25	7.5	7.6
26	21.4	16.0	14.25	7.5	8.0
28	21.4	16.0	14.25	7.5	8.4
30	21.4	16.0	14.25	7.5	8.8
32	21.4	16.0	14.25	7.5	9.2

- NOTE 1. SUFFIX "-R8000" OF THE PART NUMBER INDICATES THAT 8000 PCS. OF WP7A-S\*\*\*VA1 CONNECTORS ARE ACCOMMODATED IN REEL.  
 2. THE LABEL, IN WHICH PART NO., NO. OF CONTACTS, LOT NO., TAPE WIDTH AND FEED PITCH ARE MARKED IS TO BE ATTACHED ON THE MAGAZINE AS SHOWN.  
 3. REFER TO THE DRAWING SJ111877 (WP7A-S\*\*\*VA1) FOR THE DIMENSIONS OF THE CONNECTOR.  
 4. LOT NO. IS MARKED AS SHOWN IN BELOW FIGURE MARKING.

- 注1. "WP7A-S\*\*\*VA1-R8000"は収納数 8000個入りのリールに収納された品名を表す。  
 2. 図示の位置に右記のシールを貼り、品名、収納数、ロットNo.、及びテープ幅と送りピッチを記入すること。  
 3. コネクタ寸法は、SJ111877 (WP7A-S\*\*\*VA1)を参照のこと。  
 4. ロットNo.を表示する、表示方法は下記による。

符号 No.	名称 DESCRIPTION	個数 QTY.	材料 MATERIAL	仕上 FINISH	備考 REMARKS
4	REEL リール	—	PS	—	—
3	COVER TAPE カバーテープ	—	PET	—	—
2	CARRIER TAPE キャリアテープ	1	PS	—	—
1	CONNECTOR コネクタ	8000	—	—	WP7A-S***VA1 SJ111877 (NOTE 3)

(EX.) 16 08 25  
 MANUFACTURE YEAR.  
製造西暦  
 MANUFACTURE MONTH.  
製造月  
 MANUFACTURE DAY.  
製造日

現品ラベル/ARTICLE LABEL  
 品名 (DESCRIPTION) WP7A-S\*\*\*VA1-R8000  
 図番 (PART No.) SJ118069  
 数量 (Q'ty) 8,000  
 ITEM NO.  
 Lot No.  
 E. Code. TB\*\*\*08  
 2016/08/25  
 Japan Aviation Electronics Industry, Ltd.  
 MADE IN JAPAN  
 QCF-C-0628 (07.12) / JAPS-9006-2

仕様書 (SPECIFICATION) JACS-10814	第1版 (ORIGINAL DATE) 06/SEP/2016	尺度 (SCALE) 1:5	シリーズ (SERIES) WP7A	日本航空電子工業株式会社 JAPAN AVIATION ELECTRONICS INDUSTRY, LTD.
一般公差 (GENERAL TOLERANCE) 寸法 (DIMENSION) × ± ×× ± ××× ±	角度 (ANGLES) ×° ± ×°× ±	名称 (TITLE) WP7A-S***VA1-R8000 RECEPTACLE CONNECTOR	担当者 (DR.) —	図面番号 (DRAWING NO.) SJ118069
単位 (UNIT) : mm	担当 (CHK.) T. KOBUCHI 査閲 (APPD.) K. ASHIBU 承認 (APPD.) H. OBIKANE	質量 (MASS) —	品質 (CHK.) —	版数 (VER.) 1

DCF-C-212H(12.08)

WISDOM承認 2016/09/06

SIZE A3

## Looking for pricing, stock, or lifecycle information?

Click below to explore more details on WIN SOURCE:

 [View WP7A-S026VA1-R6000 on WIN SOURCE](#)

 [JAE Electronics](#) Information

## Optimize Your Supply Chain with WIN SOURCE Solutions

-  Global Sourcing Solution
-  Obsolete Management
-  Cost Control Management
-  Shortage Management
-  Alternative Solution
-  Excess Inventory Management