



**THE DATASHEET OF
AM4967GSTR-G1**



ADJUSTABLE-SPEED SINGLE-PHASE FULL-WAVE PRE-DRIVER FOR MOTOR

Description

The DIODES™ AM4967 is a single-coil, single-phase motor pre-driver designed by bipolar process. Its rotation speed can be controlled through an external PWM. This IC requires few external components and has the merit of high efficiency which makes it suitable for use in great air volume, large current and high-voltage applications.

The AM4967 is available in SSOP-16 package.

Pin Assignments

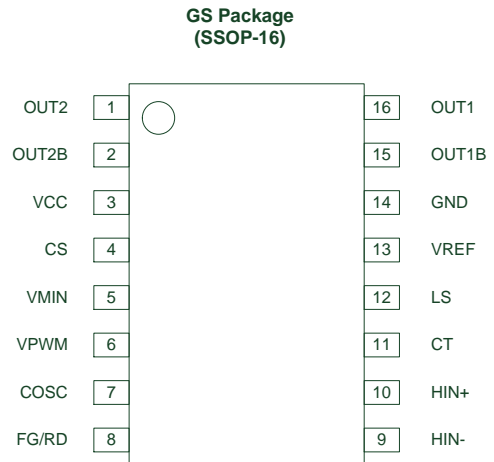

Figure 1. Pin Assignment of AM4967

Features

- Single-phase Full-wave Pre-drive
- Rotation Speed Control via External PWM
- Maximum Operating Current Limit
- Linear Start Function for Reducing Large Current Impulse at the Moment of Turn-on
- Minimum Rotation Speed Setting
- Lock Protection and Auto Start Function
- Rotation Speed Indication
- Overtemperature Protection
- **Totally Lead-Free & Fully RoHS Compliant (Notes 1 & 2)**
- **Halogen and Antimony Free. "Green" Device (Note 3)**
- **For automotive applications requiring specific change control (i.e. parts qualified to AEC-Q100/101/104/200, PPAP capable, and manufactured in IATF 16949 certified facilities), please [contact us](https://www.diodes.com/quality/product-definitions/) or your local Diodes representative. <https://www.diodes.com/quality/product-definitions/>**

Applications

- CPU and OA (Office Automation) Cooler Fan
- Brushless DC Motor



SSOP-16

Figure 2. Package Type of AM4967

Notes: 1. No purposely added lead. Fully EU Directive 2002/95/EC (RoHS), 2011/65/EU (RoHS 2) & 2015/863/EU (RoHS 3) compliant.
 2. See <https://www.diodes.com/quality/lead-free/> for more information about Diodes Incorporated's definitions of Halogen- and Antimony-free, "Green" and Lead-free.
 3. Halogen- and Antimony-free "Green" products are defined as those which contain <900ppm bromine, <900ppm chlorine (<1500ppm total Br + Cl) and <1000ppm antimony compounds.

Pin Descriptions

Pin Number	Pin Name	Function
1	OUT2	Second channel P-type driver output. Open-drain output, must be connected with pull-up resistor to drive external power devices in operation
2	OUT2B	Second channel N-type driver output. Push-pull output to drive external power devices
3	VCC	Power supply
4	CS	Current limiter indicator. Fixed to 0.2V internally. Maximum allowable current is decided by external sample resistance. When the voltage of this pin exceeds 0.2V, the output will be shut down by current limit. If this function is not used, connect this pin to ground directly
5	VMIN	Minimum speed setting terminal. Connect it to VREF when disused. In case it is tied to other power supply for controlling, an isolated resistor is necessary
6	VPWM	Speed control terminal. It is full speed mode when connected to ground. If the speed is controlled by PWM mode, the frequency of control signal is 20kHz to 100kHz. Moreover, a low pass network is necessary to transfer PWM to DC level
7	COSC	PWM basic oscillation frequency generator when connected with a capacitor of 220pF. 30kHz frequency is available.
8	FG/RD	"FG" means pin 8 is an output pin of FG signal which is used for detecting rotation speed. "RD" means pin 8 is an output pin of RD signal, and is used for detecting fan rotate-stop state. "FG" and "RD" can be selected according to the requirement. This pin need to be connected with pull-up resistor when used. A new pulse will be generated once input signal changed. Keep this pin open when it is not to be used
9	HIN-	Hall sensor negative input. To prevent noise, this pin is recommended to be placed as close as possible to Hall circuit. If necessary, a capacitor may be added between HIN+ and HIN- to reduce the influence caused by noise
10	HIN+	Hall sensor positive input. To avoid noise, this pin is recommended to be placed as close as possible to Hall circuit
11	CT	Lock protection and auto start frequency generator. It is connected with an external 0.47μF capacitor which decides lock-rotate time and start time. If lock-rotate protection function is disused, please connect this pin to GND
12	LS	Linear start terminal. This pin is connected to VREF externally via a capacitor of 0.47μF to 1μF which enables fan start steadily. Start time is dependent to the capacitance. If linear start function is not used, connect this pin to ground
13	VREF	5V voltage reference
14	GND	Ground for circuit control
15	OUT1B	First channel N-type driver output. Push-pull output to drive external power devices
16	OUT1	First channel P-type driver output. Open-drain output, must be connected with pull-up resistor to drive external power devices in operation

Functional Block Diagram

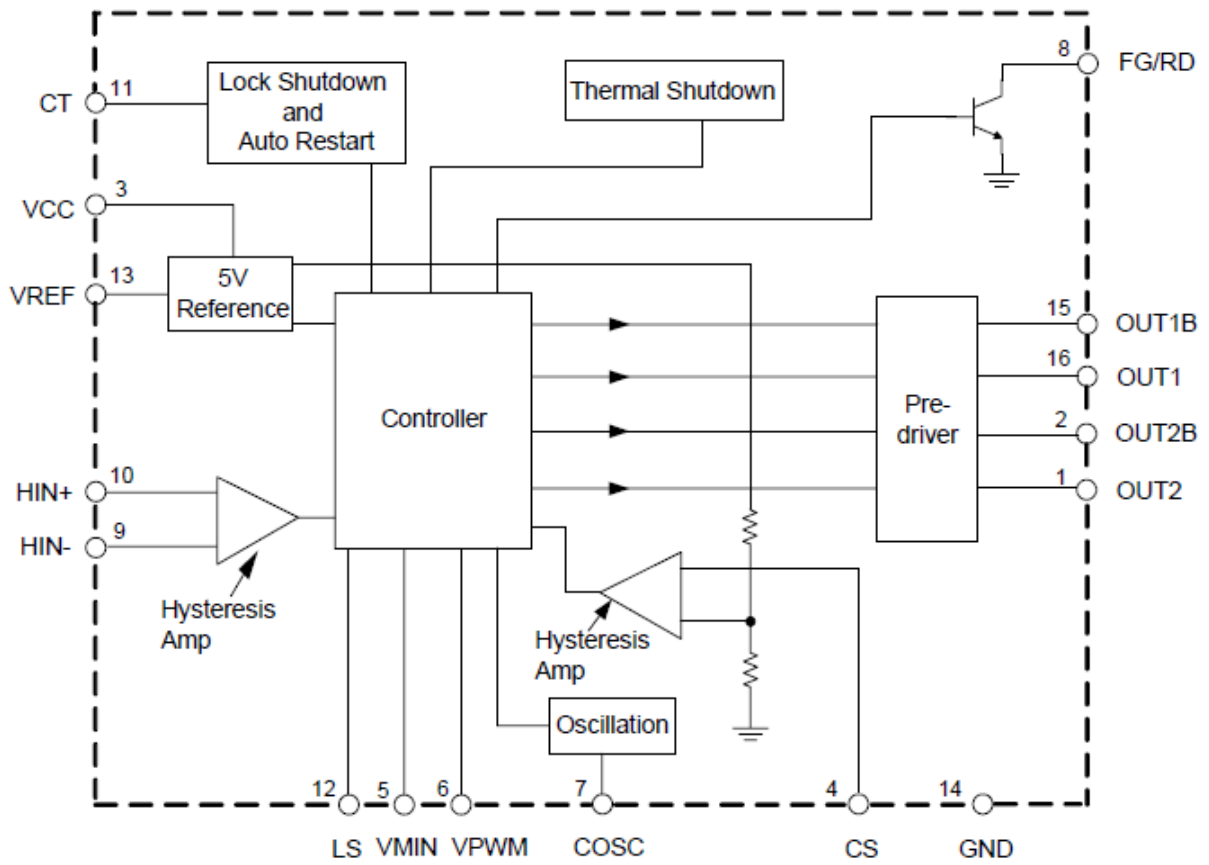

Figure 3. Functional Block Diagram of AM4967

Truth Table

1. Driver-lock. V_{OSC} is High, V_{PWM} , V_{VMIN} and V_{LS} are low.

HIN-	HIN+	CT	OUT1	OUT1B	OUT2	OUT2B	FG/RD	Mode	
H	L	L	L	L	OFF	H	L	OUT1	→ OUT2 (Driver)
L	H		OFF	H	L	L	OFF	OUT2	→ OUT1 (Driver)
H	L	H	OFF	L	OFF	H	L	Lock Protection	
L	H		OFF	H	OFF	L	OFF		

2. Speed control. V_{CT} , V_{LS} are low.

VPWM, VMIN	COSC	HIN-	HIN+	OUT1	OUT1B	OUT2	OUT2B	Mode	
L	H	H	L	L	L	OFF	H	OUT1	→ OUT2 (Driver)
		L	H	OFF	H	L	L	OUT2	→ OUT1 (Driver)
H	L	H	L	OFF	L	OFF	H	Regenerative	
		L	H	OFF	H	OFF	L		

Ordering Information (Note 4)

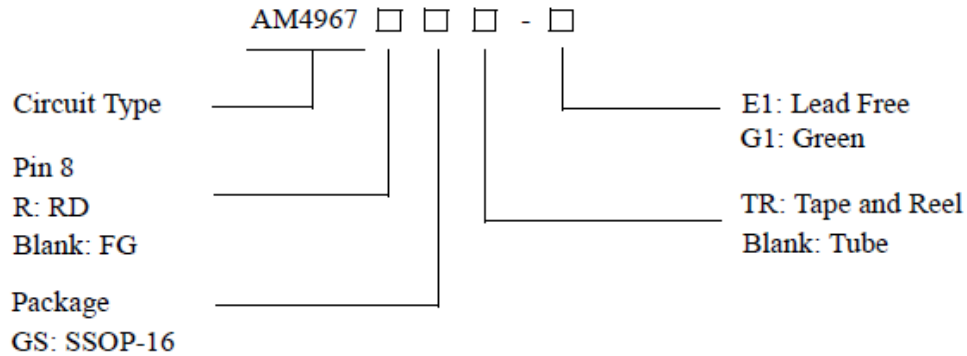

Package	Temperature	Part Number		Marking ID		Packing Type
		Lead Free	Green	Lead Free	Green	
SSOP-16	-30 to 105°C	AM4967GS-E1	AM4967GS-G1	AM4967GS	AM4967GS-G1	Tube
		AM4967GSTR-E1	AM4967GSTR-G1	AM4967GS	AM4967GS-G1	Tape & Reel
		AM4967RGS-E1	AM4967RGS-G1	AM4967RGS	AM4967RGS-G1	Tube
		AM4967RGSTR-E1	AM4967RGSTR-G1	AM4967RGS	AM4967RGS-G1	Tape & Reel

BCD Semiconductor's Pb-free products, as designated with "E1" suffix in the part number, are RoHS compliant. Products with "G1" suffix are available in green package.

Note: 4. For packaging details, go to our website at <https://www.diodes.com/design/support/packaging/diodes-packaging/>.

Absolute Maximum Ratings (Note 5)

Parameter	Symbol	Value	Unit
Supply Voltage	V_{CC}	18	V
OUT1B/OUT2B Output Current	I_{OUTB}	20	mA
OUT1/OUT2 Sink Current	I_{OUT}	20	mA
OUT1B/OUT2B/OUT1/OUT2 Withstand Voltage	V_{OUT}	18	V
VPWM/VMIN Withstand Voltage	V_{PWM}/V_{MIN}	7	V
LS Withstand Voltage	V_{LS}	7	V
FG/RD Withstand Voltage	V_{FG}/V_{RD}	V_{CC}	V
FG/RD Output Current	I_{FG}/I_{RD}	10	mA
VREF Output Current	I_{REF}	20	mA
Power Dissipation (Note 6)	P_D	800	mW
Storage Temperature Range	T_{STG}	-55 to 150	°C
ESD (Human Body Model)	ESD	2000	V

Notes: 5. Stresses greater than those listed under "Absolute Maximum Ratings" may cause permanent damage to the device. These are stress ratings only, and functional operation of the device at these or any other conditions beyond those indicated under "Recommended Operating Conditions" is not implied. Exposure to "Absolute Maximum Ratings" for extended periods may affect device reliability.
 6. When mounted on the specified printed circuit board (114.3mmX76.1mmX1.6mm, glass epoxy).

Recommended Operating Conditions

Parameter	Symbol	Min	Typ	Max	Unit
Supply Voltage	V_{CC}	5.5		16	V
VPWM/VMIN Input Voltage		0		5	V
Hall Input Voltage		0.2		3	V
Ambient Temperature	TA	-30		105	°C

Electrical Characteristics ($V_{CC}=12V$, $T_A=25^{\circ}C$, unless otherwise specified.)

Parameter	Symbol	Condition	Min	Typ	Max	Unit
Quiescent Current	IQ1	Lock off	8	10	12	mA
	IQ2	Lock on	8	10	12	
VREF Reference Voltage	VREF	IOUT=5mA	4.5	5.0	5.5	V
Current Limit Voltage	VLIM		186	200	215	mV
COSC High Level Voltage	VOSCH		3.0	3.4	3.8	V
COSC Low Level Voltage	VOSCL		0.9	1.1	1.3	V
COSC Frequency	fOSC	CL=220pF	25.4	30	35.5	kHz
CT High Level Voltage	VCTH		2.4	3.3	3.6	V
CT Low Level Voltage	VCTL		1.0	1.3	1.6	V
CT Charge Current	ICHG	VCT=0.5V	1.5	2	2.5	μA
CT Discharge Current	IDHG	VCT=3.5V	0.13	0.2	0.25	μA
CT Charge and Discharge Ratio	RCD	ICHG/IDHG	8.5	10	14.5	
Linear Start Charge Current	ILS	VLS=1V		0.5	0.7	μA
OUT1B/OUT2B High Level Voltage	VOBH	IOUT=10mA	$V_{CC} \sim 1.8$	$V_{CC} \sim 0.9$	V_{CC}	V
OUT1B/OUT2B Low Level Voltage	VOBL	IOUT=10mA		0.9	1.5	V
OUT1/OUT2 Low Level Voltage	VOL	IOUT=10mA		0.45	0.8	V
FG Signal Hall Input Sensitivity	VHN	I _{HIN+} , I _{HIN-} difference voltage (include offset and hysteresis)		± 10		mV
FG Saturation Voltage	VSAT	ISINK=5mA		200	500	mV
FG Leakage Current	ILFG	VFG=VCC			30	μA
VPWM/VMIN Bias Current	IPWMB/IVMINB	VOSC=VPWM/VVMIN=2V		0.1	3	μA

Typical Performance Characteristics

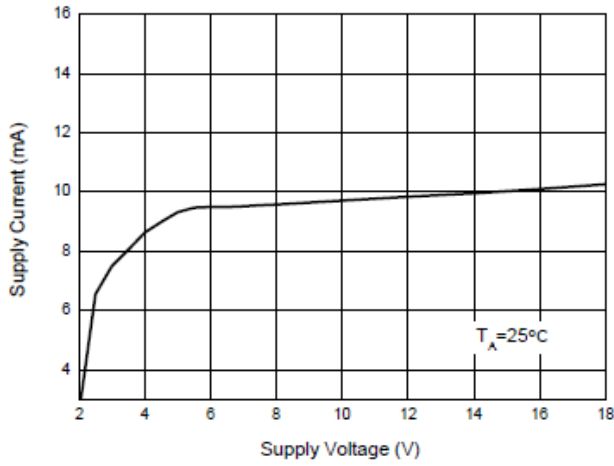

Figure 4. Supply Current vs. Supply Voltage

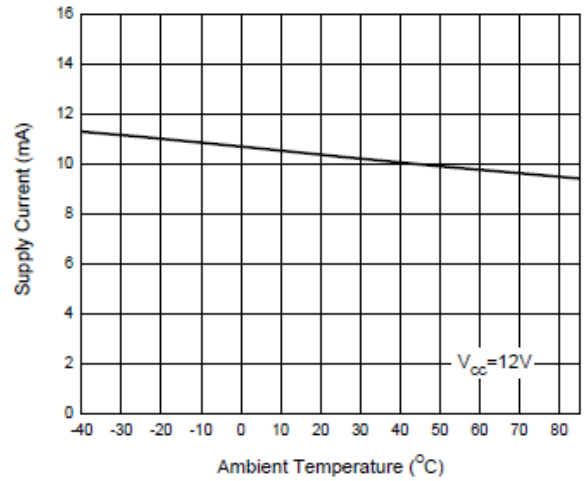

Figure 5. Supply Current vs. Ambient Temperature

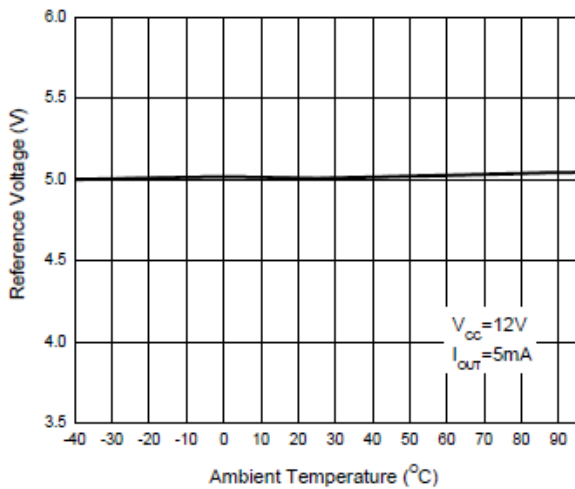

Figure 6. Reference Voltage vs. Ambient Temperature

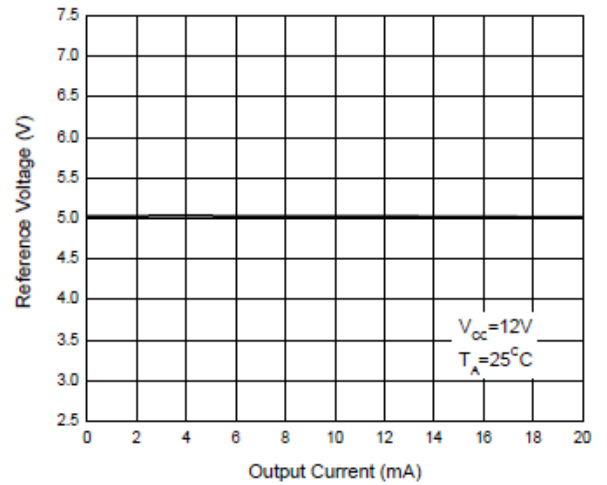

Figure 7. Reference Voltage vs. Output

Current

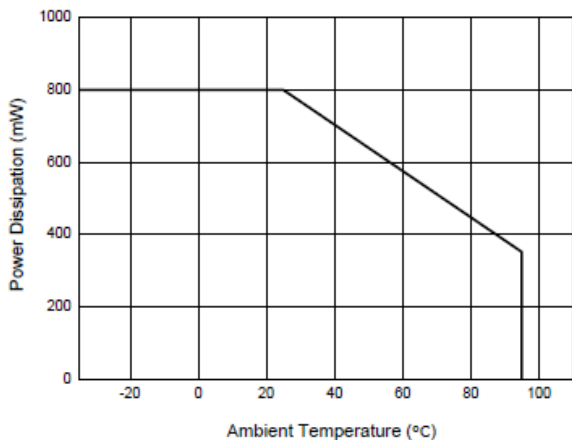

Figure 8. Power Dissipation vs. Ambient Temperature

Operating Diagram

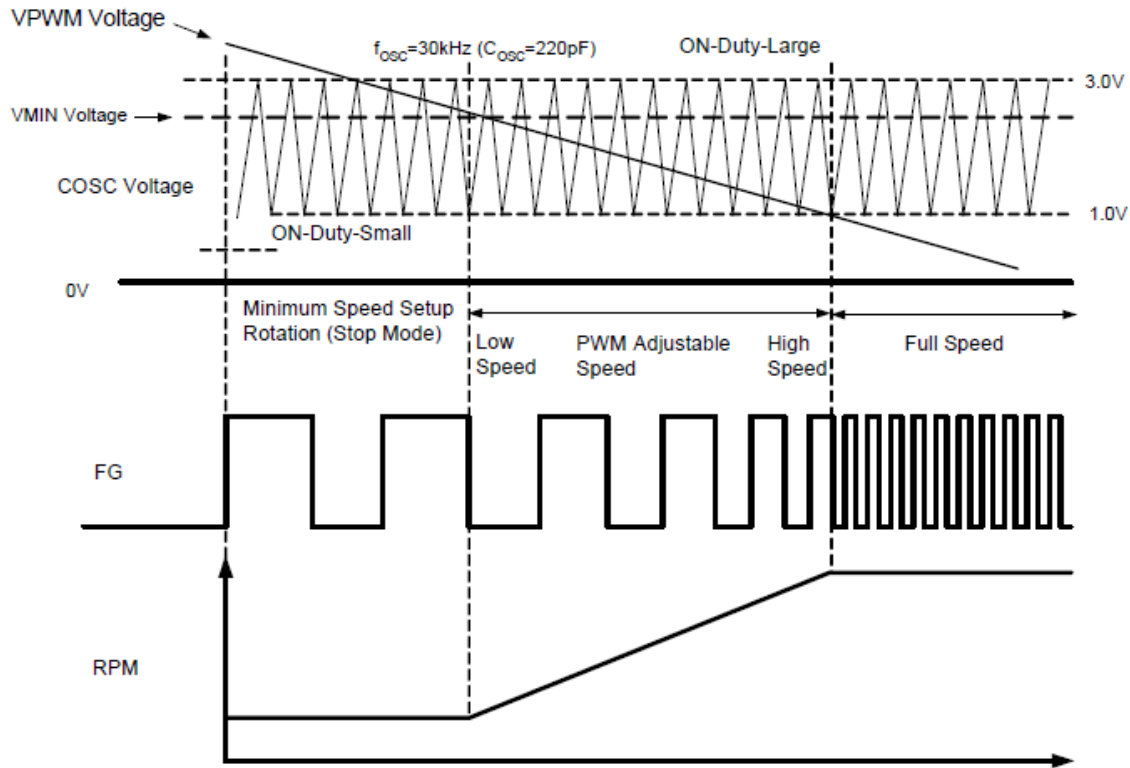

Figure 9. Operating Diagram 1 of AM4967 (Speed Control, Note 7)

Note:

7.
 - a. Minimum Speed Setting Mode (Stop Mode)
When fan rotate at low speed, its lowest speed is settable by VMIN pin voltage. If not, fan motor stops.
 - b. Low Speed to High Speed Setting Mode
PWM control system works by comparing the voltage of VPWM and COSC (1.0V to 3.0V). When VPWM voltage is low, the transistors of the upper and lower side outputs are ON. On contrary, when VPWM voltage is high, the upper side transistors are OFF. And coil current re-circulates in a lower side transistor. Therefore, as the VPWM voltage becomes lower, output ON duty becomes large. Sequentially, coil current increases and the motor runs at high speed which is monitored by FG output while rotation-stop state is monitored by RD output.
 - c. Full Speed Rotation Mode
When VPWM voltage drops to 1.0V or lower, motor fan will run at full speed. (If the speed is not controlled, VPWM=GND)

Operating Diagram (Continued)

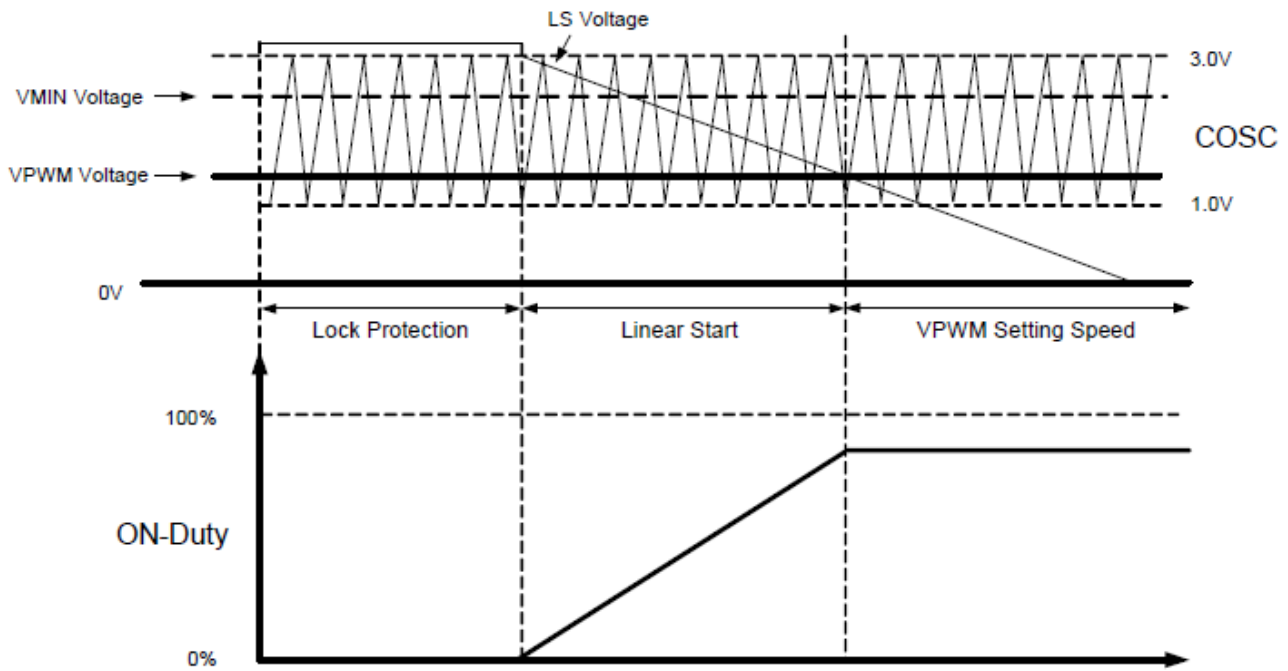

Figure 10. Operating Diagram 2 of AM4967 (Linear Start, VPWM Voltage < VMIN Voltage, Note 4)

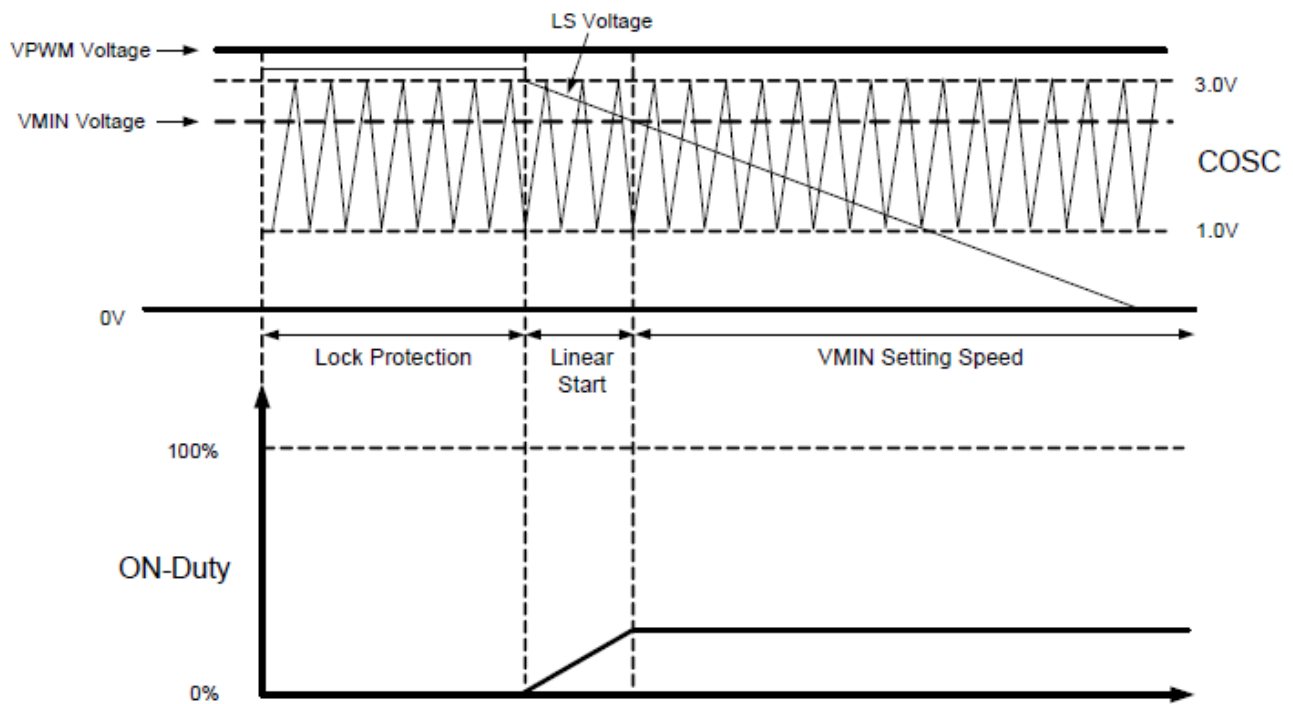

Figure 11. Operating Diagram 3 of AM4967 (Linear Start, VPWM Voltage > VMIN Voltage, Note 4)

Operating Diagram (Continued)

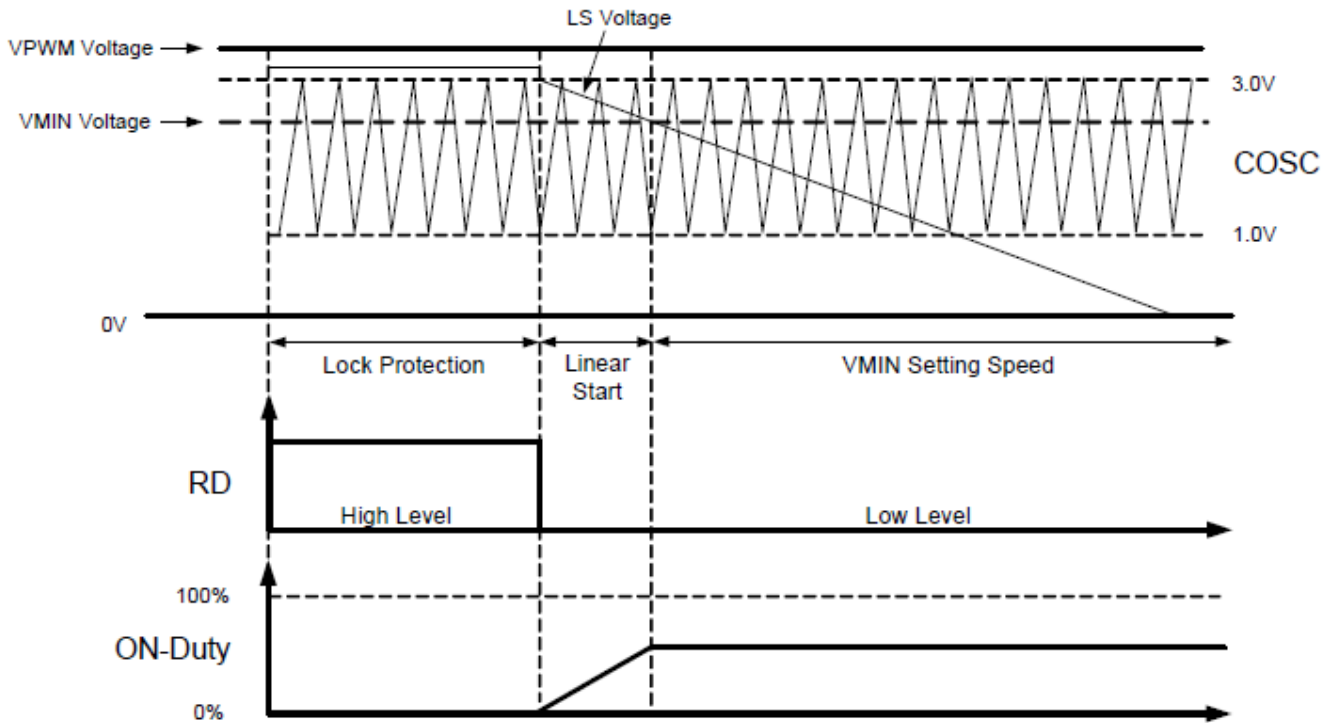

Figure 12. Operating Diagram 4 of AM4967 (Note 8)

Note: 8. The inclination of LS voltage is adjusted between VLS and VREF according to the capacitance which is recommended to be 0.1 μ F to 1.0 μ F

Typical Application

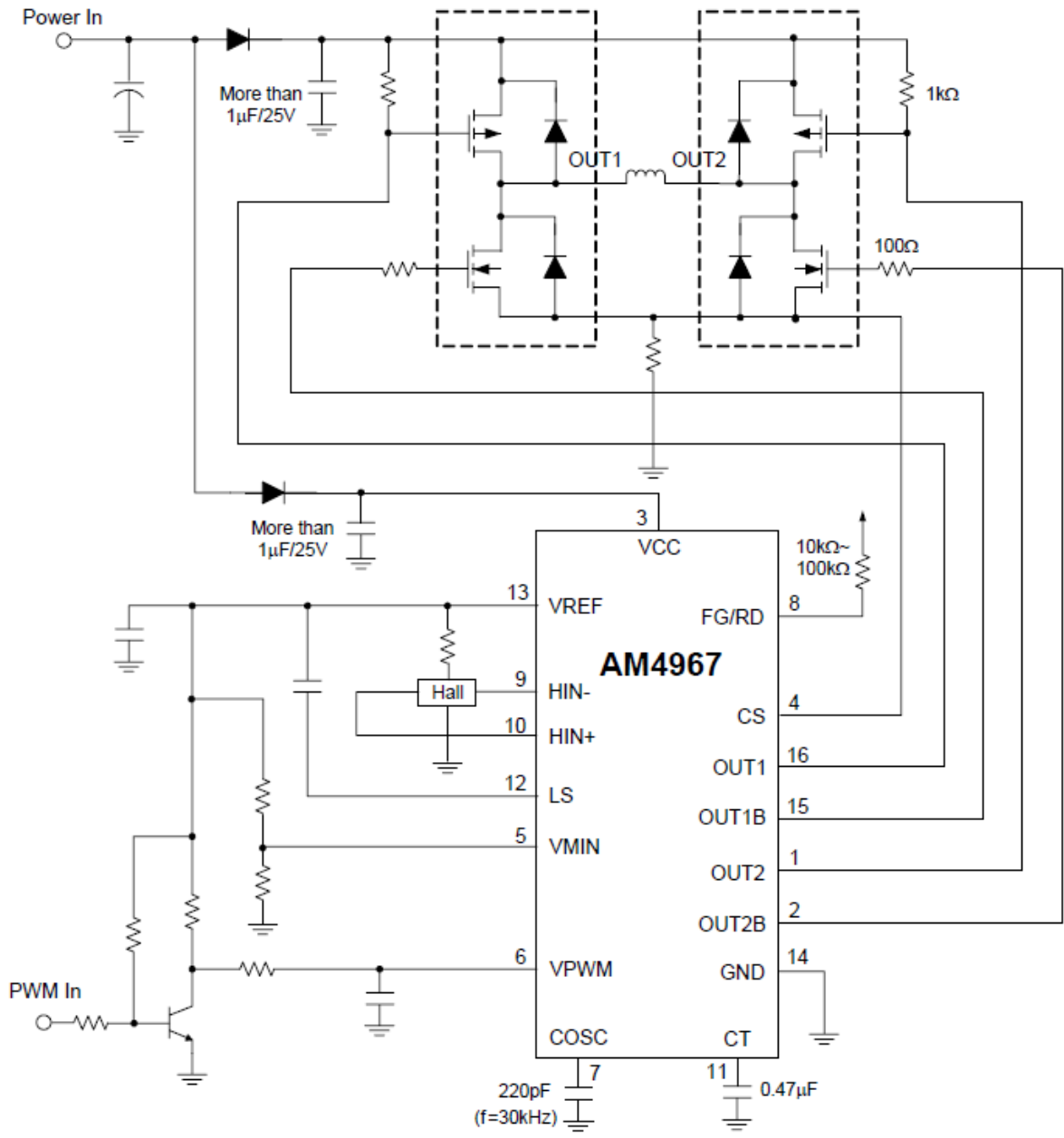

Figure 13. Typical Application of AM4967 (VCC=12V)

Package Outline Dimensions

Please see <http://www.diodes.com/package-outlines.html> for the latest version.

SSOP-16

Unit: mm(inch)

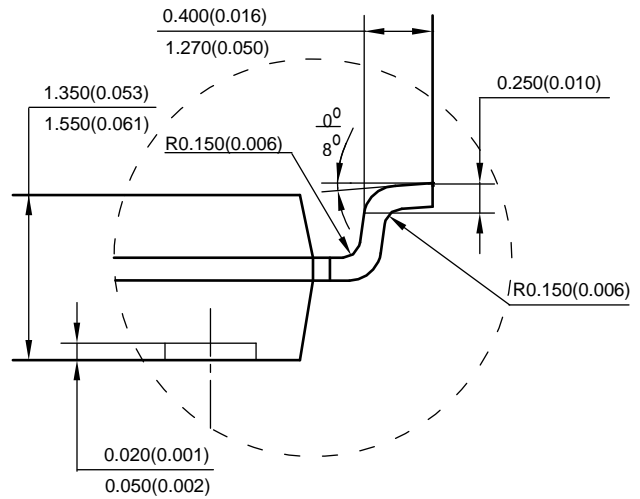
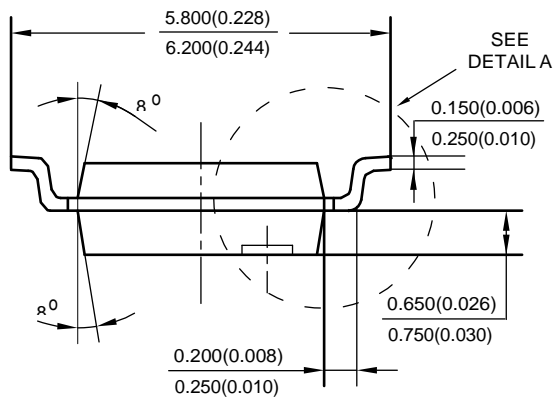
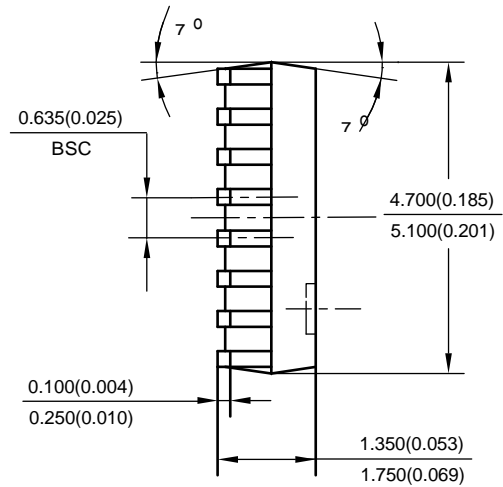
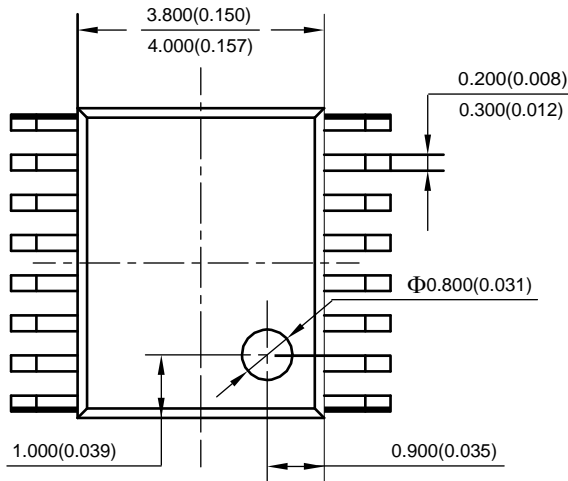

DETAIL A

Suggested Pad Layout

Please see <http://www.diodes.com/package-outlines.html> for the latest version.

SSOP-16

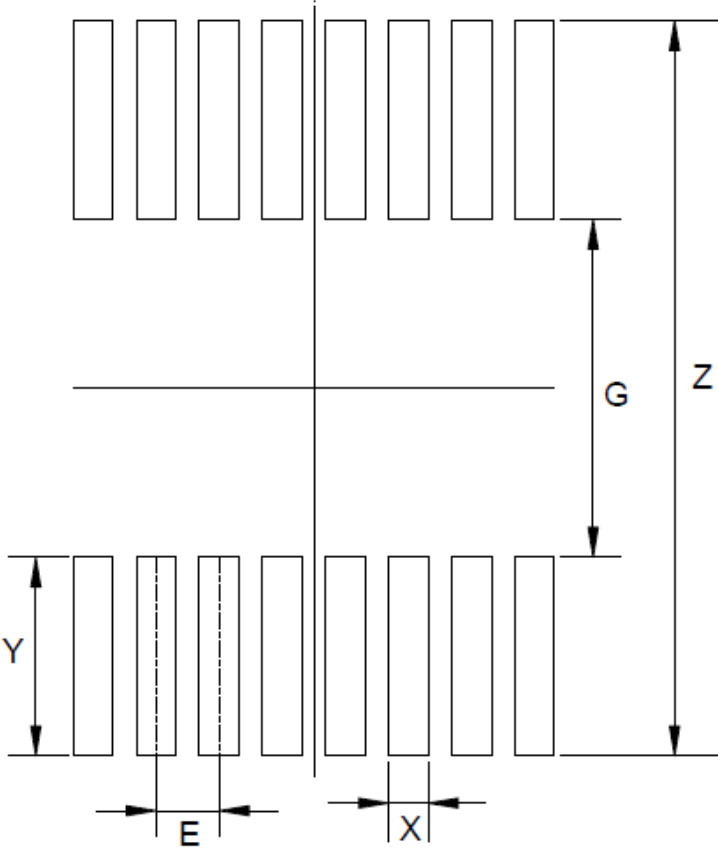

Dimensions	Z (mm)/(inch)	G (mm)/(inch)	X (mm)/(inch)	Y (mm)/(inch)	E (mm)/(inch)
Value	7.400/0.291	3.400/0.134	0.400/0.016	2.000/0.079	0.635/0.025

IMPORTANT NOTICE

1. DIODES INCORPORATED (Diodes) AND ITS SUBSIDIARIES MAKE NO WARRANTY OF ANY KIND, EXPRESS OR IMPLIED, WITH REGARDS TO ANY INFORMATION CONTAINED IN THIS DOCUMENT, INCLUDING, BUT NOT LIMITED TO, THE IMPLIED WARRANTIES OF MERCHANTABILITY, FITNESS FOR A PARTICULAR PURPOSE OR NON-INFRINGEMENT OF THIRD PARTY INTELLECTUAL PROPERTY RIGHTS (AND THEIR EQUIVALENTS UNDER THE LAWS OF ANY JURISDICTION).
2. The Information contained herein is for informational purpose only and is provided only to illustrate the operation of Diodes' products described herein and application examples. Diodes does not assume any liability arising out of the application or use of this document or any product described herein. This document is intended for skilled and technically trained engineering customers and users who design with Diodes' products. Diodes' products may be used to facilitate safety-related applications; however, in all instances customers and users are responsible for (a) selecting the appropriate Diodes products for their applications, (b) evaluating the suitability of Diodes' products for their intended applications, (c) ensuring their applications, which incorporate Diodes' products, comply the applicable legal and regulatory requirements as well as safety and functional-safety related standards, and (d) ensuring they design with appropriate safeguards (including testing, validation, quality control techniques, redundancy, malfunction prevention, and appropriate treatment for aging degradation) to minimize the risks associated with their applications.
3. Diodes assumes no liability for any application-related information, support, assistance or feedback that may be provided by Diodes from time to time. Any customer or user of this document or products described herein will assume all risks and liabilities associated with such use, and will hold Diodes and all companies whose products are represented herein or on Diodes' websites, harmless against all damages and liabilities.
4. Products described herein may be covered by one or more United States, international or foreign patents and pending patent applications. Product names and markings noted herein may also be covered by one or more United States, international or foreign trademarks and trademark applications. Diodes does not convey any license under any of its intellectual property rights or the rights of any third parties (including third parties whose products and services may be described in this document or on Diodes' website) under this document.
5. Diodes' products are provided subject to Diodes' Standard Terms and Conditions of Sale (<https://www.diodes.com/about/company/terms-and-conditions/terms-and-conditions-of-sales/>) or other applicable terms. This document does not alter or expand the applicable warranties provided by Diodes. Diodes does not warrant or accept any liability whatsoever in respect of any products purchased through unauthorized sales channel.
6. Diodes' products and technology may not be used for or incorporated into any products or systems whose manufacture, use or sale is prohibited under any applicable laws and regulations. Should customers or users use Diodes' products in contravention of any applicable laws or regulations, or for any unintended or unauthorized application, customers and users will (a) be solely responsible for any damages, losses or penalties arising in connection therewith or as a result thereof, and (b) indemnify and hold Diodes and its representatives and agents harmless against any and all claims, damages, expenses, and attorney fees arising out of, directly or indirectly, any claim relating to any noncompliance with the applicable laws and regulations, as well as any unintended or unauthorized application.
7. While efforts have been made to ensure the information contained in this document is accurate, complete and current, it may contain technical inaccuracies, omissions and typographical errors. Diodes does not warrant that information contained in this document is error-free and Diodes is under no obligation to update or otherwise correct this information. Notwithstanding the foregoing, Diodes reserves the right to make modifications, enhancements, improvements, corrections or other changes without further notice to this document and any product described herein. This document is written in English but may be translated into multiple languages for reference. Only the English version of this document is the final and determinative format released by Diodes.
8. Any unauthorized copying, modification, distribution, transmission, display or other use of this document (or any portion hereof) is prohibited. Diodes assumes no responsibility for any losses incurred by the customers or users or any third parties arising from any such unauthorized use.
9. This Notice may be periodically updated with the most recent version available at <https://www.diodes.com/about/company/terms-and-conditions/important-notice>

DIODES is a trademark of Diodes Incorporated in the United States and other countries.
The Diodes logo is a registered trademark of Diodes Incorporated in the United States and other countries.
© 2022 Diodes Incorporated. All Rights Reserved.

www.diodes.com

Looking for pricing, stock, or lifecycle information?

Click below to explore more details on WIN SOURCE:

-  [View AM4967GSTR-G1 on WIN SOURCE](#)
-  [Diodes Incorporated Information](#)

Optimize Your Supply Chain with WIN SOURCE Solutions

-  Global Sourcing Solution
-  Obsolete Management
-  Cost Control Management
-  Shortage Management
-  Alternative Solution
-  Excess Inventory Management