



**THE DATASHEET OF
954101DGLFT**



Programmable Timing Control Hub™ for Desktop P4™ Systems

Recommended Application:

CK410 clock, Intel Yellow Cover part

Output Features:

- 2 - 0.7V current-mode differential CPU pairs
- 6 - 0.7V current-mode differential SRC pair for SATA and PCI-E
- 1 - 0.7V current-mode differential CPU/SRC selectable pair
- 6 - PCI (33MHz)
- 3 - PCICLK_F, (33MHz) free-running
- 1 - USB, 48MHz
- 1 - DOT, 96MHz, 0.7V current differential pair
- 1 - REF, 14.318MHz

Key Specifications:

- CPU outputs cycle-cycle jitter < 85ps
- SRC output cycle-cycle jitter < 125ps
- PCI outputs cycle-cycle jitter < 500ps
- +/- 300ppm frequency accuracy on CPU & SRC clocks

Features/Benefits:

- Supports tight ppm accuracy clocks for Serial-ATA and PCI-Express
- Supports spread spectrum modulation, 0 to -0.5% down spread
- Supports CPU clks up to 400MHz
- Uses external 14.318MHz crystal, external crystal load caps are required for frequency tuning
- Supports undriven differential CPU, SRC pair in PD# for power management.

Functionality

FS_C ¹	FS_B ²	FS_A ²	CPU MHz	SRC MHz	PCI MHz	REF MHz	USB MHz	DOT MHz
0	0	0	266.66	100.00	33.33	14.318	48.00	96.00
0	0	1	133.33	100.00	33.33	14.318	48.00	96.00
0	1	0	200.00	100.00	33.33	14.318	48.00	96.00
0	1	1	166.66	100.00	33.33	14.318	48.00	96.00
1	0	0	333.33	100.00	33.33	14.318	48.00	96.00
1	0	1	100.00	100.00	33.33	14.318	48.00	96.00
1	1	0	400.00	100.00	33.33	14.318	48.00	96.00
1	1	1	RESERVED			14.318	48.00	96.00

1. FS_C is a three-level input. Please see V_{IL,FS} and V_{IH,FS} specifications in the Input/Supply/Common Output Parameters Table for correct values. Also refer to the Test Clarification Table.
2. FS_B and FS_A are low-threshold inputs. Please see the V_{IL,FS} and V_{IH,FS} specifications in the Input/Supply/Common Output Parameters Table for correct values.

Pin Configuration

VDDPCI	1	56	PCICLK2
GND	2	55	PCICLK1
PCICLK3	3	54	PCICLK0
PCICLK4	4	53	FS_C/TEST_SEL
PCICLK5	5	52	REFOUT
GND	6	51	GND
VDDPCI	7	50	X1
ITP_EN/PCICLK_F0	8	49	X2
PCICLK_F1	9	48	VDDREF
PCICLK_F2	10	47	SDATA
VDD48	11	46	SCLK
USB_48MHz	12	45	GND
GND	13	44	CPUCLKT0
DOTT_96MHz	14	43	CPUCLKC0
DOTC_96MHz	15	42	VDDCPU
FS_B/TEST_MODE	16	41	CPUCLKT1
Vtt_PwrGd#/PD	17	40	CPUCLKC1
FS_A_410	18	39	IREF
SRCCLKT1	19	38	GND
SRCCLKC1	20	37	VDDA
VDDSRC	21	36	CPUCLKT2_ITP/SRCCLKT_7
SRCCLKT2	22	35	CPUCLKC2_ITP/SRCCLKC_7
SRCCLKC2	23	34	VDDSRC
SRCCLKT3	24	33	SRCCLKT6
SRCCLKC3	25	32	SRCCLKC6
SRCCLKT4_SATA	26	31	SRCCLKT5
SRCCLKC4_SATA	27	30	SRCCLKC5
VDDSRC	28	29	GND

56-pin SSOP & TSSOP

Pin Description

Pin #	PIN NAME	PIN TYPE	DESCRIPTION
1	VDDPCI	PWR	Power supply for PCI clocks, nominal 3.3V
2	GND	PWR	Ground pin.
3	PCICLK3	OUT	PCI clock output.
4	PCICLK4	OUT	PCI clock output.
5	PCICLK5	OUT	PCI clock output.
6	GND	PWR	Ground pin.
7	VDDPCI	PWR	Power supply for PCI clocks, nominal 3.3V
8	ITP_EN/PCICLK_F0	I/O	Free running PCI clock not affected by PCI_STOP#. ITP_EN: latched input to select pin functionality 1 = CPU_ITP pair 0 = SRC pair
9	PCICLK_F1	OUT	Free running PCI clock not affected by PCI_STOP# .
10	PCICLK_F2	OUT	Free running PCI clock not affected by PCI_STOP# .
11	VDD48	PWR	Power pin for the 48MHz output.3.3V
12	USB_48MHz	OUT	48.00MHz USB clock
13	GND	PWR	Ground pin.
14	DOTT_96MHz	OUT	True clock of differential pair for 96.00MHz DOT clock.
15	DOTC_96MHz	OUT	Complement clock of differential pair for 96.00MHz DOT clock.
16	FS_B/TEST_MODE	IN	3.3V tolerant input for CPU frequency selection. Refer to input electrical characteristics for Vil_FS and Vih_FS values. TEST_MODE is a real time input to select between Hi-Z and REF/N divider mode while in test mode. Refer to Test Clarification Table.
17	Vtt_PwrGd#/PD	IN	Vtt_PwrGd# is an active low input used to determine when latched inputs are ready to be sampled. PD is an asynchronous active high input pin used to put the device into a low power state. The internal clocks, PLLs and the crystal oscillator are stopped.
18	FS_A_410	IN	3.3V tolerant low threshold input for CPU frequency selection. This pin requires CK410 FSA. Refer to input electrical characteristics for Vil_FS and Vih_FS threshold values.
19	SRCCLKT1	OUT	True clock of differential SRC clock pair.
20	SRCCLKC1	OUT	Complement clock of differential SRC clock pair.
21	VDDSRC	PWR	Supply for SRC clocks, 3.3V nominal
22	SRCCLKT2	OUT	True clock of differential SRC clock pair.
23	SRCCLKC2	OUT	Complement clock of differential SRC clock pair.
24	SRCCLKT3	OUT	True clock of differential SRC clock pair.
25	SRCCLKC3	OUT	Complement clock of differential SRC clock pair.
26	SRCCLKT4_SATA	OUT	True clock of differential SRC/SATA pair.
27	SRCCLKC4_SATA	OUT	Complement clock of differential SRC/SATA pair.
28	VDDSRC	PWR	Supply for SRC clocks, 3.3V nominal

Pin Description (Continued)

Pin #	PIN NAME	TYPE	DESCRIPTION
29	GND	PWR	Ground pin.
30	SRCCLK5	OUT	Complement clock of differential SRC clock pair.
31	SRCCLKT5	OUT	True clock of differential SRC clock pair.
32	SRCCLK6	OUT	Complement clock of differential SRC clock pair.
33	SRCCLKT6	OUT	True clock of differential SRC clock pair.
34	VDDSRC	PWR	Supply for SRC clocks, 3.3V nominal
35	CPUCLKC2_ITP/SRCCLKC_7	OUT	Complimentary clock of CPU_ITP/SRC differential pair CPU_ITP/SRC output. These are current mode outputs. External resistors are required for voltage bias. Selected by ITP_EN input.
36	CPUCLKT2_ITP/SRCCLKT_7	OUT	True clock of CPU_ITP/SRC differential pair CPU_ITP/SRC output. These are current mode outputs. External resistors are required for voltage bias. Selected by ITP_EN input.
37	VDDA	PWR	3.3V power for the PLL core.
38	GND A	PWR	Ground pin for the PLL core.
39	IREF	OUT	This pin establishes the reference current for the differential current-mode output pairs. This pin requires a fixed precision resistor tied to ground in order to establish the appropriate current. 475 ohms is the standard value.
40	CPUCLKC1	OUT	Complimentary clock of differential pair CPU outputs. These are current mode outputs. External resistors are required for voltage bias.
41	CPUCLKT1	OUT	True clock of differential pair CPU outputs. These are current mode outputs. External resistors are required for voltage bias.
42	VDDCPU	PWR	Supply for CPU clocks, 3.3V nominal
43	CPUCLKC0	OUT	Complimentary clock of differential pair CPU outputs. These are current mode outputs. External resistors are required for voltage bias.
44	CPUCLKT0	OUT	True clock of differential pair CPU outputs. These are current mode outputs. External resistors are required for voltage bias.
45	GND	PWR	Ground pin.
46	SCLK	IN	Clock pin of SMBus circuitry, 5V tolerant.
47	SDATA	I/O	Data pin for SMBus circuitry, 5V tolerant.
48	VDDREF	PWR	Ref, XTAL power supply, nominal 3.3V
49	X2	OUT	Crystal output, Nominally 14.318MHz
50	X1	IN	Crystal input, Nominally 14.318MHz.
51	GND	PWR	Ground pin.
52	REFOUT	OUT	Reference Clock output
53	FS_C/TEST_SEL	IN	3.3V tolerant input for CPU frequency selection. Low voltage threshold inputs, see input electrical characteristics for V_{il_FS} and V_{ih_FS} values. TEST_Sel: 3-level latched input to enable test mode. Refer to Test Clarification Table
54	PCICLK0	OUT	PCI clock output.
55	PCICLK1	OUT	PCI clock output.
56	PCICLK2	OUT	PCI clock output.

General Description

ICS954101 follows Intel CK410 Yellow Cover specification. This clock synthesizer provides a single chip solution for next generation P4 Intel processors and Intel chipsets. **ICS954101** is driven with a 14.318MHz crystal. It generates CPU outputs up to 400MHz. It also provides a tight ppm accuracy output for Serial ATA and PCI-Express support.

Block Diagram

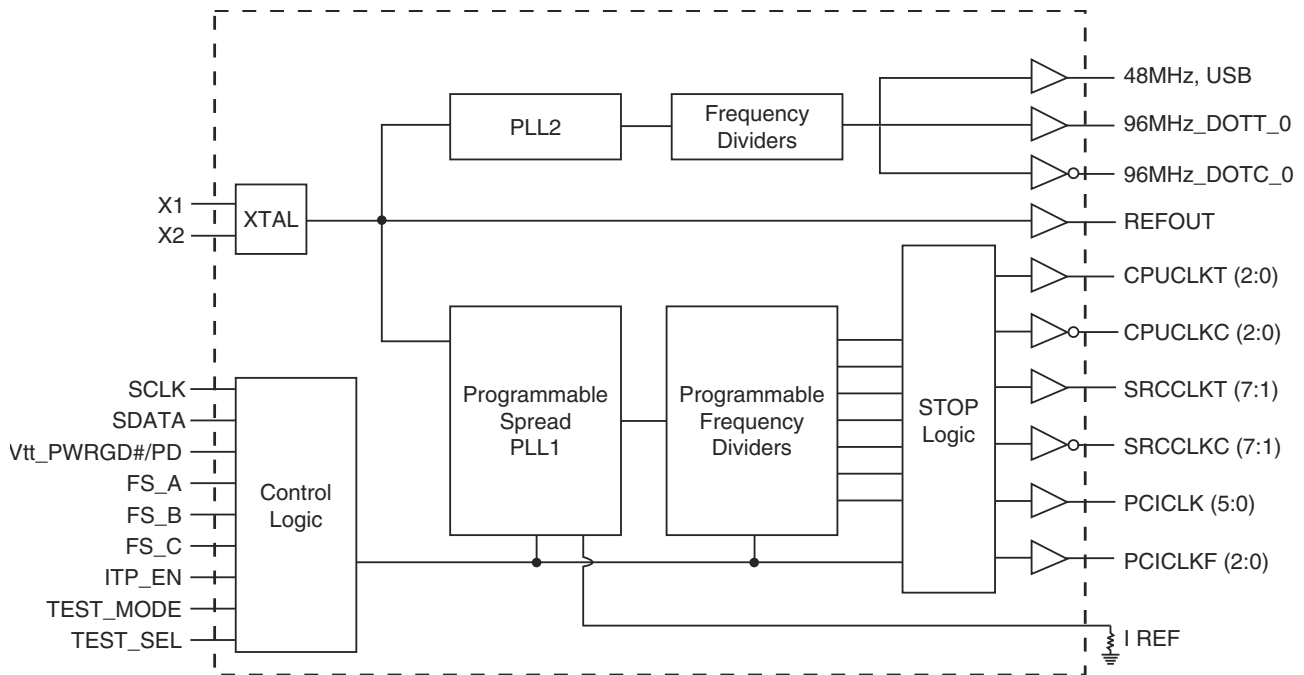

Power Groups

Pin Number		Description
VDD	GND	
48	51	Xtal, Ref
1,7	2,6	PCICLK outputs
21,28,34	29	SRCCLK outputs
37	38	Master clock, CPU Analog
11	13	DOT, USB, PLL_48
42	45	CPUCLK clocks

General I²C serial interface information for the ICS954101

How to Write:

- Controller (host) sends a start bit.
- Controller (host) sends the write address $D2_{(H)}$
- ICS clock will **acknowledge**
- Controller (host) sends the beginning byte location = N
- ICS clock will **acknowledge**
- Controller (host) sends the data byte count = X
- ICS clock will **acknowledge**
- Controller (host) starts sending **Byte N through Byte N + X - 1**
(see Note 2)
- ICS clock will **acknowledge** each byte **one at a time**
- Controller (host) sends a Stop bit

How to Read:

- Controller (host) will send start bit.
- Controller (host) sends the write address $D2_{(H)}$
- ICS clock will **acknowledge**
- Controller (host) sends the beginning byte location = N
- ICS clock will **acknowledge**
- Controller (host) will send a separate start bit.
- Controller (host) sends the read address $D3_{(H)}$
- ICS clock will **acknowledge**
- ICS clock will send the data byte count = X
- ICS clock sends **Byte N + X - 1**
- ICS clock sends **Byte 0 through byte X (if $X_{(H)}$ was written to byte 8).**
- Controller (host) will need to acknowledge each byte
- Controller (host) will send a not acknowledge bit
- Controller (host) will send a stop bit

Index Block Write Operation		
Controller (Host)		ICS (Slave/Receiver)
T	starT bit	
Slave Address $D2_{(H)}$		
WR	WRite	
		ACK
Beginning Byte = N		
		ACK
Data Byte Count = X		
		ACK
Beginning Byte N		X Byte
○		
○		
○		
○		
Byte N + X - 1		
		ACK
P	stoP bit	

Index Block Read Operation			
Controller (Host)		ICS (Slave/Receiver)	
T	starT bit		
Slave Address $D2_{(H)}$			
WR	WRite		
		ACK	
Beginning Byte = N			
		ACK	
RT	Repeat starT		
Slave Address $D3_{(H)}$			
RD	ReaD		
		ACK	
		Data Byte Count = X	
ACK			
ACK		X Byte	
			Beginning Byte N
○			
○			
○			
		Byte N + X - 1	
N	Not acknowledge		
P	stoP bit		

Absolute Max

Symbol	Parameter	Min	Max	Units
VDD_A	3.3V Core Supply Voltage		$V_{DD} + 0.5V$	V
VDD_In	3.3V Logic Input Supply Voltage	GND - 0.5	$V_{DD} + 0.5V$	V
Ts	Storage Temperature	-65	150	°C
Tambient	Ambient Operating Temp	0	70	°C
Tcase	Case Temperature		115	°C
ESD prot	Input ESD protection human body model	2000		V

Electrical Characteristics - Input/Supply/Common Output Parameters

T_A = 0 - 70°C; Supply Voltage V_{DD} = 3.3 V +/-5%

PARAMETER	SYMBOL	CONDITIONS	MIN	TYP	MAX	UNITS	NOTES
Input High Voltage	V _{IH}	3.3 V +/-5%	2		V _{DD} + 0.3	V	
Input Low Voltage	V _{IL}	3.3 V +/-5%	V _{SS} - 0.3		0.8	V	
Input High Current	I _{IH}	V _{IN} = V _{DD}	-5		5	uA	
Input Low Current	I _{IL1}	V _{IN} = 0 V; Inputs with no pull-up resistors	-5			uA	
	I _{IL2}	V _{IN} = 0 V; Inputs with pull-up resistors	-200			uA	
Low Threshold Input High Voltage	V _{IH_FS}	3.3 V +/-5%	0.7		V _{DD} + 0.3	V	
Low Threshold Input Low Voltage	V _{IL_FS}	3.3 V +/-5%	V _{SS} - 0.3		0.35	V	
Operating Supply Current	I _{DD3.3OP}	3.3 V +/-5%, Full Load		350	500	mA	
Powerdown Current	I _{DD3.3PD}	all diff pairs driven			70	mA	
		all differential pairs tri-stated			12	mA	
Input Frequency ³	F _i	V _{DD} = 3.3 V		14.31818		MHz	3
Pin Inductance ¹	L _{pin}				7	nH	1
Input Capacitance ¹	C _{IN}	Logic Inputs			5	pF	1
	C _{OUT}	Output pin capacitance			6	pF	1
	C _{INX}	X1 & X2 pins			5	pF	1
Clk Stabilization ^{1,2}	T _{STAB}	From V _{DD} Power-Up or de-assertion of PD# to 1st clock			1.8	ms	1,2
Modulation Frequency		Triangular Modulation	30		33	kHz	1
Tdrive_PD#		CPU output enable after PD# de-assertion			300	us	1
Tfall_Pd#		PD# fall time of			5	ns	1
Trise_Pd#		PD# rise time of			5	ns	2
SMBus Voltage	V _{DD}		2.7		5.5	V	1
Low-level Output Voltage	V _{OL} SMBUS	@ I _{PULLUP}			0.4	V	1
Current sinking at V _{OL} = 0.4 V	I _{PULLUP}		4			mA	1
SCLK/SDATA Clock/Data Rise Time	T _{RI2C}	(Max V _{IL} - 0.15) to (Min V _{IH} + 0.15)			1000	ns	1
SCLK/SDATA Clock/Data Fall Time	T _{FI2C}	(Min V _{IH} + 0.15) to (Max V _{IL} - 0.15)			300	ns	1

¹Guaranteed by design and characterization, not 100% tested in production.

²See timing diagrams for timing requirements.

³Input frequency should be measured at the REF output pin and tuned to ideal 14.31818MHz to meet ppm accuracy on PLL outputs.

Electrical Characteristics - CPU 0.7V Current Mode Differential Pair

$T_A = 0 - 70^\circ\text{C}$; $V_{DD} = 3.3\text{ V} \pm 5\%$; $C_L = 2\text{pF}$, $R_S = 33.2\Omega$, $R_P = 49.9\Omega$, $I_{REF} = 475\Omega$

PARAMETER	SYMBOL	CONDITIONS	MIN	TYP	MAX	UNITS	NOTES
Current Source Output Impedance	Zo	$V_O = V_x$	3000			Ω	1
Voltage High	VHigh	Statistical measurement on single ended signal using oscilloscope math function.	660		850	mV	1
Voltage Low	VLow		-150		150		1
Max Voltage	Vovs	Measurement on single ended signal using absolute value.			1150	mV	1
Min Voltage	Vuds		-300				1
Crossing Voltage (abs)	Vcross(abs)		250		550	mV	1
Crossing Voltage (var)	d-Vcross	Variation of crossing over all edges			140	mV	1
Long Accuracy	ppm	see Tperiod min-max values	-300		300	ppm	1,2
Average period	Tperiod	400MHz nominal	2.4993		2.5008	ns	2
		400MHz spread	2.4993		2.5133	ns	2
		333.33MHz nominal	2.9991		3.0009	ns	2
		333.33MHz spread	2.9991		3.016	ns	2
		266.66MHz nominal	3.7489		3.7511	ns	2
		266.66MHz spread	3.7489		3.77	ns	2
		200MHz nominal	4.9985		5.0015	ns	2
		200MHz spread	4.9985		5.0266	ns	2
		166.66MHz nominal	5.9982		6.0018	ns	2
		166.66MHz spread	5.9982		6.0320	ns	2
		133.33MHz nominal	7.4978		7.5023	ns	2
		133.33MHz spread	7.4978		5.4000	ns	2
		100.00MHz nominal	9.9970		10.0030	ns	2
		100.00MHz spread	9.9970		10.0533	ns	2
Absolute min period	T _{absmin}	400MHz nominal/spread	2.4143			ns	1,2
		333.33MHz nominal/spread	2.9141			ns	1,2
		266.66MHz nominal/spread	3.6639			ns	1,2
		200MHz nominal/spread	4.8735			ns	1,2
		166.66MHz nominal/spread	5.8732			ns	1,2
		133.33MHz nominal/spread	7.3728			ns	1,2
Rise Time	t _r	$V_{OL} = 0.175\text{V}$, $V_{OH} = 0.525\text{V}$	175		700	ps	1
Fall Time	t _f	$V_{OH} = 0.525\text{V}$, $V_{OL} = 0.175\text{V}$	175		700	ps	1
Rise Time Variation	d-t _r				125	ps	1
Fall Time Variation	d-t _f				125	ps	1
Duty Cycle	d _{t3}	Measurement from differential waveform	45		55	%	1
Skew	t _{sk3}	CPU (1:0) $V_T = 50\%$			100	ps	1
Skew	t _{sk4}	CPU (1:0) to CPU_ITP, $V_T = 50\%$			150	ps	1
Jitter, Cycle to cycle	t _{jyc-cyc}	Measurement from differential waveform			85	ps	1

¹Guaranteed by design, not 100% tested in production.

²All Long Term Accuracy and Clock Period specifications are guaranteed assuming that REFoutput is at 14.31818MHz

Electrical Characteristics - SRC 0.7V Current Mode Differential Pair

$T_A = 0 - 70^\circ\text{C}$; $V_{DD} = 3.3\text{ V} \pm 5\%$; $C_L = 2\text{pF}$, $R_S = 33.2\Omega$, $R_P = 49.9\Omega$, $I_{REF} = 475\mu\text{A}$

PARAMETER	SYMBOL	CONDITIONS	MIN	TYP	MAX	UNITS	NOTES
Current Source Output Impedance	Zo	$V_O = V_x$	3000			Ω	1
Voltage High	VHigh	Statistical measurement on single ended signal using oscilloscope	660		850	mV	1
Voltage Low	VLow		-150		150		1
Max Voltage	Vovs	Measurement on single ended signal using absolute value.			1150	mV	1
Min Voltage	Vuds		-300				1
Crossing Voltage (abs)	Vcross(abs)		250	350	550	mV	1
Crossing Voltage (var)	d-Vcross	Variation of crossing over all edges		12	140	mV	1
Long Accuracy	ppm	see Tperiod min-max values	-300		300	ppm	1,2
Average period	Tperiod	100.00MHz nominal	9.9970		10.0030	ns	2
		100.00MHz spread	9.9970		10.0533	ns	2
Absolute min period	Tabsmin	100.00MHz nominal/spread	9.8720			ns	1,2
Rise Time	t _r	$V_{OL} = 0.175\text{V}$, $V_{OH} = 0.525\text{V}$	175		700	ps	1
Fall Time	t _f	$V_{OH} = 0.525\text{V}$, $V_{OL} = 0.175\text{V}$	175		700	ps	1
Rise Time Variation	d-t _r			30	125	ps	1
Fall Time Variation	d-t _f			30	125	ps	1
Duty Cycle	d _{t3}	Measurement from differential waveform	45		55	%	1
Skew	t _{sk3}	SRC(7:0), $V_T = 50\%$			250	ps	1
Jitter, Cycle to cycle	t _{jyc-cyc}	Measurement from differential waveform			125	ps	1

¹Guaranteed by design, not 100% tested in production.

²All Long Term Accuracy and Clock Period specifications are guaranteed assuming that REFOutput is at 14.31818MHz

Electrical Characteristics - PCICLK/PCICLK_F

T_A = 0 - 70°C; V_{DD} = 3.3 V +/-5%; C_L = 30 pF (unless otherwise specified)

PARAMETER	SYMBOL	CONDITIONS	MIN	TYP	MAX	UNITS	Notes
Long Accuracy	ppm	see Tperiod min-max values	-300		300	ppm	1,2
Clock period	T _{period}	33.33MHz output nominal	29.99100		30.00900	ns	2
		33.33MHz output spread	29.99100		30.15980	ns	2
Absolute Min/Max Clock period	T _{abs}	33.33MHz output nominal	29.49100		30.50900	ns	2
		33.33MHz output spread	29.49100		30.65980	ns	2
Clk High Time	t _{h1}		12		N/A	ns	1
Clock Low Time	t _{l1}		12		N/A	ns	1
Output High Voltage	V _{OH}	I _{OH} = -1 mA	2.4			V	
Output Low Voltage	V _{OL}	I _{OL} = 1 mA			0.55	V	
Output High Current	I _{OH}	V _{OH} @ MIN = 1.0 V	-33			mA	
		V _{OH} @ MAX = 3.135 V			-33	mA	
Output Low Current	I _{OL}	V _{OL} @ MIN = 1.95 V	30			mA	
		V _{OL} @ MAX = 0.4 V			38	mA	
Edge Rate		Rising edge rate	1		4	V/ns	1
Edge Rate		Falling edge rate	1		4	V/ns	1
Rise Time	t _{r1}	V _{OL} = 0.4 V, V _{OH} = 2.4 V	0.5		2	ns	1
Fall Time	t _{f1}	V _{OH} = 2.4 V, V _{OL} = 0.4 V	0.5		2	ns	1
Duty Cycle	d _{t1}	V _T = 1.5 V	45		55	%	1
Skew	t _{sk1}	V _T = 1.5 V			500	ps	1
Jitter	t _{jvc-cyc}	V _T = 1.5 V			500	ps	1

¹Guaranteed by design, not 100% tested in production.

²All Long Term Accuracy and Clock Period specifications are guaranteed assuming that REFoutput is at 14.31818MHz

Electrical Characteristics - USB_48MHz

T_A = 0 - 70°C; V_{DD} = 3.3 V +/-5%; C_L = 20 pF (unless otherwise specified)

PARAMETER	SYMBOL	CONDITIONS	MIN	TYP	MAX	UNITS	Notes
Long Accuracy	ppm	see Tperiod min-max values	-100		100	ppm	1,2
Clock period	T _{period}	48.0000MHz output nominal	20.82570		20.83400	ns	2
Absolute Min/Max Clock period	T _{abs}	Nominal	20.48125		21.18542	ns	2
Clk High Time	t _{h1}		8.094		10.036	ns	1
Clock Low Time	t _{l1}		7.694		9.836	ns	1
Output High Current	I _{OH}	V _{OH} @ MIN = 1.0 V	-33			mA	
		V _{OH} @ MAX = 3.135 V			-33	mA	
Output Low Current	I _{OL}	V _{OL} @ MIN = 1.95 V	30			mA	
		V _{OL} @ MAX = 0.4 V			38	mA	
Edge Rate		Rising edge rate	1		2	V/ns	1
Edge Rate		Falling edge rate	1		2	V/ns	1
Rise Time	t _{r1}	V _{OL} = 0.4 V, V _{OH} = 2.4 V	1	1.4	2	ns	1
Fall Time	t _{f1}	V _{OH} = 2.4 V, V _{OL} = 0.4 V	1	1.3	2	ns	1
Duty Cycle	d _{t1}	V _T = 1.5 V	45	48	55	%	1
Jitter, Cycle to cycle	t _{jvc-cyc}	V _T = 1.5 V			350	ps	1

¹Guaranteed by design, not 100% tested in production.

²All Long Term Accuracy and Clock Period specifications are guaranteed assuming that REFoutput is at 14.31818MHz

Electrical Characteristics - DOT, 96MHz 0.7V Current Mode Differential Pair

$T_A = 0 - 70^\circ\text{C}$; $V_{DD} = 3.3\text{ V} \pm 5\%$; $C_L = 2\text{pF}$, $R_S = 33.2\Omega$, $R_P = 49.9\Omega$, $I_{REF} = 475\mu\text{A}$

PARAMETER	SYMBOL	CONDITIONS	MIN	TYP	MAX	UNITS	NOTES
Current Source Output Impedance	Z_o	$V_o = V_x$	3000			Ω	1
Voltage High	VHigh	Statistical measurement on single ended signal	660		850	mV	1
Voltage Low	VLow		-150		150		1
Max Voltage	Vovs	Measurement on single ended signal using			1150	mV	1
Min Voltage	Vuds		-300				1
Crossing Voltage (abs)	Vcross(abs)		250		550	mV	1
Crossing Voltage (var)	d-Vcross	Variation of crossing over all edges			140	mV	1
Long Accuracy	ppm	see Tperiod min-max values	-100		100	ppm	1,2
Average period	Tperiod	96.00MHz nominal	10.4135		10.4198	ns	2
Absolute min period	Tabmin	96.00MHz nominal	10.1635			ns	1,2
Rise Time	t_r	$V_{OL} = 0.175\text{V}$, $V_{OH} = 0.525\text{V}$	175		700	ps	1
Fall Time	t_f	$V_{OH} = 0.525\text{V}$, $V_{OL} = 0.175\text{V}$	175		700	ps	1
Rise Time Variation	d- t_r				125	ps	1
Fall Time Variation	d- t_f				125	ps	1
Duty Cycle	d_{13}	Measurement from differential waveform	45		55	%	1
Jitter, Cycle to cycle	$t_{j\text{cyc-cyc}}$	Measurement from differential waveform			250	ps	1

¹Guaranteed by design, not 100% tested in production.

²All Long Term Accuracy and Clock Period specifications are guaranteed assuming that REFOutput is at 14.31818MHz

Electrical Characteristics - REF-14.318MHz

$T_A = 0 - 70^\circ\text{C}$; $V_{DD} = 3.3 \text{ V} \pm 5\%$; $C_L = 20 \text{ pF}$ (unless otherwise specified)

PARAMETER	SYMBOL	CONDITIONS	MIN	TYP	MAX	UNITS	NOTES
Long Accuracy	ppm	see Tperiod min-max values	-300		300	ppm	1
Clock period	T_{period}	14.318MHz output nominal	69.82700		69.85500	ns	1
Absolute Min/Max Clock period	T_{abs}	Nominal	68.82033		70.86224	ns	2
Output High Voltage	V_{OH}	$I_{\text{OH}} = -1 \text{ mA}$	2.4			V	1
Output Low Voltage	V_{OL}	$I_{\text{OL}} = 1 \text{ mA}$			0.4	V	1
Output High Current	I_{OH}	$V_{\text{OH}} @ \text{MIN} = 1.0 \text{ V}$, $V_{\text{OH}} @ \text{MAX} = 3.135 \text{ V}$	-29		-23	mA	1
Output Low Current	I_{OL}	$V_{\text{OL}} @ \text{MIN} = 1.95 \text{ V}$, $V_{\text{OL}} @ \text{MAX} = 0.4 \text{ V}$	29		27	mA	1
Rise Time	t_{r1}	$V_{\text{OL}} = 0.4 \text{ V}$, $V_{\text{OH}} = 2.4 \text{ V}$	1		2	ns	1
Fall Time	t_{f1}	$V_{\text{OH}} = 2.4 \text{ V}$, $V_{\text{OL}} = 0.4 \text{ V}$	1		2	ns	1
Duty Cycle	d_{t1}	$V_T = 1.5 \text{ V}$	45		55	%	1
Jitter	$t_{\text{jyc-cyc}}$	$V_T = 1.5 \text{ V}$			1000	ps	1

¹Guaranteed by design, not 100% tested in production.

I²C Table: Read-Back Register

Byte 0	Pin #	Name	Control Function	Type	0	1	PWD	
Bit 7	35,36	CPUCLK2/RCCLK7 Enable	Output Enable	RW	DISABLE	ENABLE	1	
Bit 6	32,33	SRCLK6 Enable	Output Enable	RW	DISABLE	ENABLE	1	
Bit 5	30,31	SRCLK5 Enable	Output Enable	RW	DISABLE	ENABLE	1	
Bit 4	26,27	SRCLK4 Enable	Output Enable	RW	DISABLE	ENABLE	1	
Bit 3	24,25	SRCLK3 Enable	Output Enable	RW	DISABLE	ENABLE	1	
Bit 2	22,23	SRCLK2 Enable	Output Enable	RW	DISABLE	ENABLE	1	
Bit 1	19,20	SRCLK1 Enable	Output Enable	RW	DISABLE	ENABLE	1	
Bit 0	-	RESERVED						

I²C Table: Spreading and Device Behavior Control Register

Byte 1	Pin #	Name	Control Function	Type	0	1	PWD
Bit 7	54	PCI_F0 Enable	Output Enable	RW	Disable	Enable	1
Bit 6	14,15	DOT_96MHz	Output Enable	RW	Disable	Enable	1
Bit 5	12	USB_48MHz Enable	Output Enable	RW	Disable	Enable	1
Bit 4	52	REFOUT Enable	Output Enable	RW	Disable	Enable	1
Bit 3		RESERVED					1
Bit 2	40,41	CPUT1/CPUC1	Output Enable	RW	Disable	Enable	1
Bit 1	43,44	CPUT0/CPUC0	Output Enable	RW	Disable	Enable	1
Bit 0	-	Spread Spectrum Mode	Spread Off	RW	SPREAD OFF	SPREAD ON	0

I²C Table: Output Control Register

Byte 2	Pin #	Name	Control Function	Type	0	1	PWD
Bit 7	5	PCICLK5	Output Enable	RW	Disable	Enable	1
Bit 6	4	PCICLK4	Output Enable	RW	Disable	Enable	1
Bit 5	3	PCICLK3	Output Enable	RW	Disable	Enable	1
Bit 4	56	PCICLK2	Output Enable	RW	Disable	Enable	1
Bit 3	55	PCICLK1	Output Enable	RW	Disable	Enable	1
Bit 2	54	PCICLK0	Output Enable	RW	Disable	Enable	1
Bit 1	10	PCI_F2 Enable	Output Enable	RW	Disable	Enable	1
Bit 0	9	PCI_F1 Enable	Output Enable	RW	Disable	Enable	1

I²C Table: Output Control Register

Byte 3	Pin #	Name	Control Function	Type	0	1	PWD
Bit 7	35,35	CPU_ITP/SRCCLK7	Free-Running Control default: not affected by PCI/SRC_STOP (Byte 6, bit 3)	RW	Free-Running	Stoppable	0
Bit 6	32,33	SRCLK6		RW	Free-Running	Stoppable	0
Bit 5	30,31	SRCLK5		RW	Free-Running	Stoppable	0
Bit 4	26,27	SRCLK4		RW	Free-Running	Stoppable	0
Bit 3	24,25	SRCLK3		RW	Free-Running	Stoppable	0
Bit 2	22,23	SRCLK2		RW	Free-Running	Stoppable	0
Bit 1	19,20	SRCLK1		RW	Free-Running	Stoppable	0
Bit 0	-	RESERVED					0

I²C Table: Output Control Register

Byte 4	Pin #	Name	Control Function	Type	0	1	PWD
Bit 7			RESERVED				1
Bit 6	14,15	DOT_96MHz	Driven in PD	RW	Driven	Hi-Z	1
Bit 5	10	PCI_F2	Free-Running Control not affected by	RW	Free-Running	Stoppable	1
Bit 4	9	PCI_F1		RW	Free-Running	Stoppable	1
Bit 3	8	PCI_F0		RW	Free-Running	Stoppable	1
Bit 2			RESERVED				1
Bit 1			RESERVED				1
Bit 0			RESERVED				1

I²C Table: Output Control Register

Byte 5	Pin #	Name	Control Function	Type	0	1	PWD
Bit 7	19,20,22,23, 24,25,26,27,30,31, 32,33,35,36	SRC Stop Drive Mode	Drive Mode in PCI_Stop	RW	Driven	Hi-Z	0
Bit 6			RESERVED				0
Bit 5			RESERVED				0
Bit 4			RESERVED				0
Bit 3	19,20,22,23, 24,25,26,27,30,31, 32,33,35,36	SRC PD Drive Mode	Drive Mode in PD	RW	Driven	Hi-Z	0
Bit 2	35,36	CPUCLK_ITP	Drive Mode in PD	RW	Driven	Hi-Z	0
Bit 1	40,41	CPUCLK1	Drive mode in PD	RW	Driven	Hi-Z	0
Bit 0	43,44	CPUCLK0	Drive mode in PD	RW	Driven	Hi-Z	0

I²C Table: Output Control Register

Byte 6	Pin #	Name	Control Function	Type	0	1	PWD
Bit 7	-	Test Mode Selection	Test Mode Selection	RW	Hi-Z	REF/N	0
Bit 6	-	Test Clock Mode Entry	Test Mode	RW	Disable	Enable	0
Bit 5	-		RESERVED				0
Bit 4	52	REFOUT Strength	Strength Prog	RW	1X	2X	1
Bit 3	17,18,19,20,22,23, 24,25,26,27,30,31, 32,33,35,36 54,55,56,3,4,5,8,9, 10	PCI/SRC_STOP	Stop all PCI and SRC clocks	RW	Enabled, all stoppable PCI and SRC clocks are stopped.	Disabled, all stoppable PCI and SRC clocks are running	1
Bit 2	-	FS_C	readback	R	-	-	LATCHED
Bit 1	-	FS_B	readback	R	-	-	LATCHED
Bit 0	-	FS_A	readback	R	-	-	LATCHED

I²C Table: Vendor & Revision ID Register

Byte 7	Pin #	Name	Control Function	Type	0	1	PWD
Bit 7	-	RID3	REVISION ID	R	-	-	0
Bit 6	-	RID2		R	-	-	0
Bit 5	-	RID1		R	-	-	0
Bit 4	-	RID0		R	-	-	0
Bit 3	-	VID3	VENDOR ID	R	-	-	0
Bit 2	-	VID2		R	-	-	0
Bit 1	-	VID1		R	-	-	0
Bit 0	-	VID0		R	-	-	1

Test Clarification Table

Comments	HW		SW		OUTPUT
	FS_C/TEST_SEL HW PIN	FS_B/TEST_MODE HW PIN	TEST ENTRY BIT B6b6	REF/N or HI-Z B6b7	
	0	X	0	X	NORMAL
<ul style="list-style-type: none"> · FS_C/TEST_SEL is a 3-level latched input. <ul style="list-style-type: none"> o Power-up w/ V >= 2.0V to select TEST o Power-up w/ V < 2.0V to have pin function as FS_C. · When pin is FS_C, VIH_FS and VIL_FS levels apply. · FS_B/TEST_MODE is a low-threshold input <ul style="list-style-type: none"> o VIH_FS and VIL_FS levels apply. o TEST_MODE is a real time input · TEST_SEL can be invoked after power up through SMBus B6b6. <ul style="list-style-type: none"> o If TEST is selected by B6b6, only B6b7 controls TEST_MODE. The FS_B/TEST_Mode pin is not used. · Power must be cycled to exit TEST. 	1	0	X	0	HI-Z
	1	0	X	1	REF/N
	1	1	X	0	REF/N
	1	1	X	1	REF/N
	0	X	1	0	HI-Z
	0	X	1	1	REF/N

B6b6: 1= ENTER TEST MODE, Default = 0 (NORMAL OPERATION)
 B6b7: 1= REF/N, Default = 0 (HI-Z)

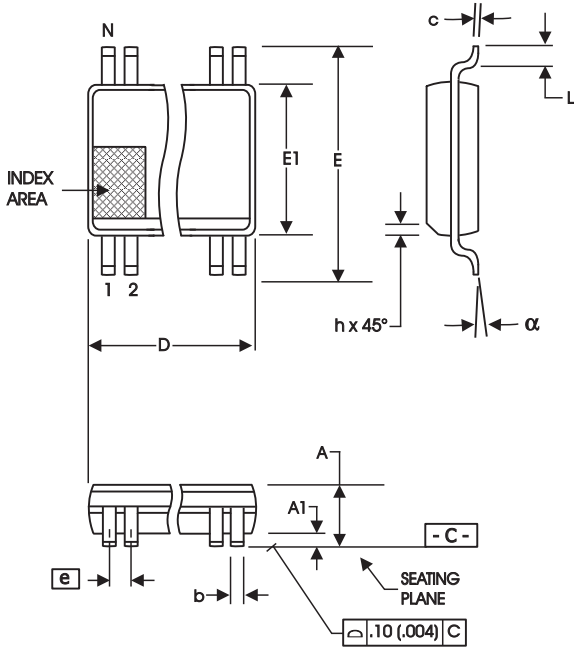

56-Lead, 300 mil Body, 25 mil, SSOP

SYMBOL	In Millimeters COMMON DIMENSIONS		In Inches COMMON DIMENSIONS	
	MIN	MAX	MIN	MAX
A	2.41	2.80	.095	.110
A1	0.20	0.40	.008	.016
b	0.20	0.34	.008	.0135
c	0.13	0.25	.005	.010
D	SEE VARIATIONS		SEE VARIATIONS	
E	10.03	10.68	.395	.420
E1	7.40	7.60	.291	.299
e	0.635 BASIC		0.025 BASIC	
h	0.38	0.64	.015	.025
L	0.50	1.02	.020	.040
N	SEE VARIATIONS		SEE VARIATIONS	
a	0°	8°	0°	8°

VARIATIONS

N	D mm.		D (inch)	
	MIN	MAX	MIN	MAX
56	18.31	18.55	.720	.730

Reference Doc.: JEDEC Publication 95, MO-118

10-0034

Ordering Information

954101yFLFT

Example:

XXXX y FLFT

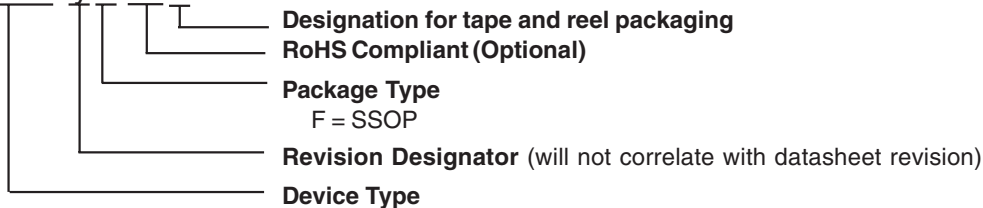

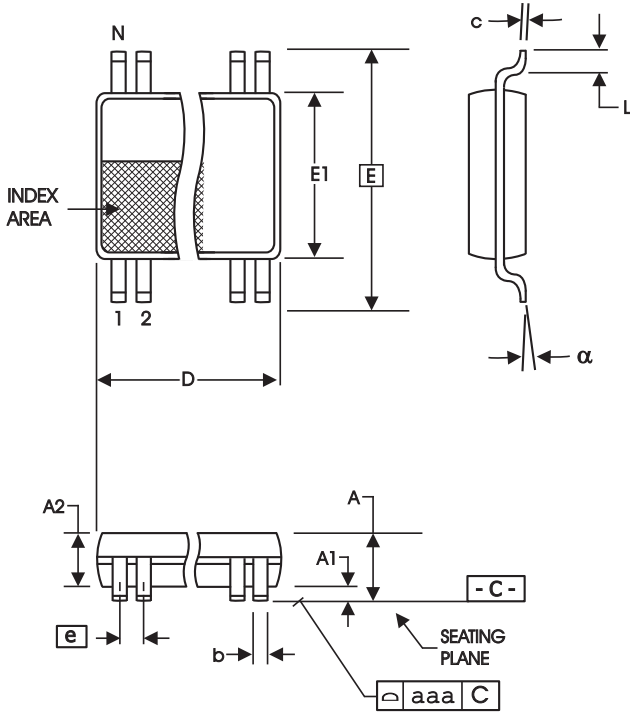

56-Lead 6.10 mm. Body, 0.50 mm. Pitch TSSOP
(240 mil) (20 mil)

SYMBOL	In Millimeters		In Inches	
	COMMON DIMENSIONS		COMMON DIMENSIONS	
	MIN	MAX	MIN	MAX
A	--	1.20	--	.047
A1	0.05	0.15	.002	.006
A2	0.80	1.05	.032	.041
b	0.17	0.27	.007	.011
c	0.09	0.20	.0035	.008
D	SEE VARIATIONS		SEE VARIATIONS	
E	8.10 BASIC		0.319 BASIC	
E1	6.00	6.20	.236	.244
e	0.50 BASIC		0.020 BASIC	
L	0.45	0.75	.018	.030
N	SEE VARIATIONS		SEE VARIATIONS	
a	0°	8°	0°	8°
aaa	--	0.10	--	.004

VARIATIONS

N	D mm.		D (inch)	
	MIN	MAX	MIN	MAX
56	13.90	14.10	.547	.555

Reference Doc.: JEDEC Publication 95, MO-153

10-0039

Ordering Information

954101yGLFT

Example:

XXXX y GLFT

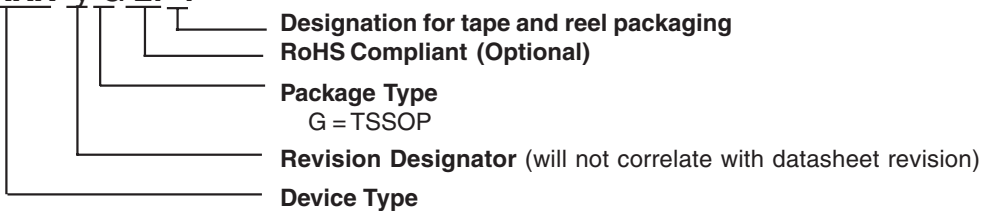

Revision History

Rev.	Issue Date	Description	Page #
E	6/1/2005	1. Updated Block Diagram. 2. Update LF Ordering Information to RoHS Compliant.	4,15-16
F	8/15/2005	1. Removed Skew from REF Electrical Characteristics Table - only 1 REF output.	11
G	12/2/2008	Removed ICS prefix from ordering information	15-16

IMPORTANT NOTICE AND DISCLAIMER

RENESAS ELECTRONICS CORPORATION AND ITS SUBSIDIARIES (“RENESAS”) PROVIDES TECHNICAL SPECIFICATIONS AND RELIABILITY DATA (INCLUDING DATASHEETS), DESIGN RESOURCES (INCLUDING REFERENCE DESIGNS), APPLICATION OR OTHER DESIGN ADVICE, WEB TOOLS, SAFETY INFORMATION, AND OTHER RESOURCES “AS IS” AND WITH ALL FAULTS, AND DISCLAIMS ALL WARRANTIES, EXPRESS OR IMPLIED, INCLUDING, WITHOUT LIMITATION, ANY IMPLIED WARRANTIES OF MERCHANTABILITY, FITNESS FOR A PARTICULAR PURPOSE, OR NON-INFRINGEMENT OF THIRD-PARTY INTELLECTUAL PROPERTY RIGHTS.

These resources are intended for developers who are designing with Renesas products. You are solely responsible for (1) selecting the appropriate products for your application, (2) designing, validating, and testing your application, and (3) ensuring your application meets applicable standards, and any other safety, security, or other requirements. These resources are subject to change without notice. Renesas grants you permission to use these resources only to develop an application that uses Renesas products. Other reproduction or use of these resources is strictly prohibited. No license is granted to any other Renesas intellectual property or to any third-party intellectual property. Renesas disclaims responsibility for, and you will fully indemnify Renesas and its representatives against, any claims, damages, costs, losses, or liabilities arising from your use of these resources. Renesas' products are provided only subject to Renesas' Terms and Conditions of Sale or other applicable terms agreed to in writing. No use of any Renesas resources expands or otherwise alters any applicable warranties or warranty disclaimers for these products.

(Disclaimer Rev.1.01 Jan 2024)

Corporate Headquarters

TOYOSU FORESIA, 3-2-24 Toyosu,
Koto-ku, Tokyo 135-0061, Japan
www.renesas.com

Trademarks

Renesas and the Renesas logo are trademarks of Renesas Electronics Corporation. All trademarks and registered trademarks are the property of their respective owners.

Contact Information

For further information on a product, technology, the most up-to-date version of a document, or your nearest sales office, please visit www.renesas.com/contact-us/.

Looking for pricing, stock, or lifecycle information?

Click below to explore more details on WIN SOURCE:

-  [View 954101DGLFT on WIN SOURCE](#)
-  [Renesas Electronics America](#) Information

Optimize Your Supply Chain with WIN SOURCE Solutions

-  Global Sourcing Solution
-  Obsolete Management
-  Cost Control Management
-  Shortage Management
-  Alternative Solution
-  Excess Inventory Management