



THE DATASHEET OF TDA7498E



160-watt + 160-watt dual BTL class-D audio amplifier

Datasheet - production data

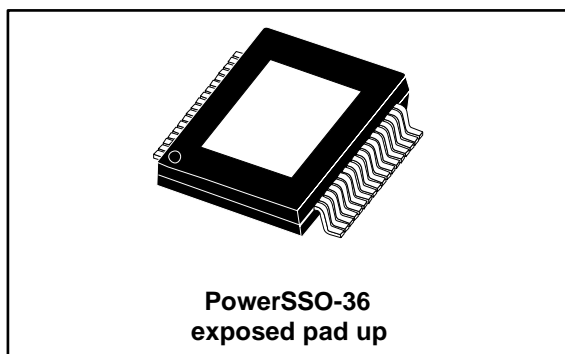
Features

- 160-W + 160-W output power at THD = 10% with $R_L = 4 \Omega$ and $V_{CC} = 36 V$
- 1 x 220 W output power mono parallel BTL at THD = 10% with $R_L = 3 \Omega$ and $V_{CC} = 36 V$
- Wide-range single-supply operation (14 - 36 V)
- High efficiency ($\eta = 85\%$)
- Parallel BTL function using the MODE pin
- Four selectable, fixed gain settings of nominally 23.8 dB, 29.8 dB, 33.3 dB and 35.8 dB

- Differential inputs minimize common-mode noise
- Standby and mute features
- Smart protection
- Thermal overload protection
- Small offset less than 20 mV

Description

The TDA7498E is a dual BTL class-D audio amplifier with a single power supply designed for home systems and active speaker applications.

It comes in a 36-pin PowerSSO package with exposed pad up (EPU) to facilitate mounting a separate heatsink.

Table 1: Device summary

Order code	Operating temp. range	Package	Packaging
TDA7498E	0 to 70 °C	PowerSSO36 (EPU)	Tube
TDA7498ETR	0 to 70 °C	PowerSSO36 (EPU)	Tape and reel

Contents

1	Device block diagram.....	5
2	Pin description	6
	2.1 Pinout.....	6
	2.2 Pin list	7
3	Electrical specifications.....	8
	3.1 Absolute maximum ratings.....	8
	3.2 Thermal data.....	8
	3.3 Recommended operating conditions.....	8
	3.4 Electrical specifications	8
	3.5 Test circuit.....	10
4	Characterization curves.....	11
	4.1 For $R_L = 4 \Omega$, stereo configuration.....	11
	4.2 For $R_L = 3 \Omega$, mono BTL configuration	12
5	Application information	13
	5.1 Stereo and mono BTL operation selection using the MODE pin	13
	5.2 Gain setting.....	13
	5.3 Smart protection.....	13
6	Package information	14
	6.1 PowerSSO-36 EPU package information.....	14
7	Revision history	17

List of tables

Table 1: Device summary	1
Table 2: Pin description list	7
Table 3: Absolute maximum ratings	8
Table 4: Thermal data	8
Table 5: Recommended operating conditions	8
Table 6: Electrical specifications	8
Table 7: Gain settings	13
Table 8: PowerSSO-36 EPU package mechanical data	16
Table 9: Document revision history	17

List of figures

Figure 1: Internal block diagram (showing one channel only)	5
Figure 2: Pin connections (top view, PCB view)	6
Figure 3: Test circuit stereo application and mono BTL mode	10
Figure 4: Output power vs. supply voltage	11
Figure 5: THD vs. output power	11
Figure 6: THD vs. frequency	11
Figure 7: FFT performance	11
Figure 8: Crosstalk vs. frequency	11
Figure 9: Output power vs. supply voltage	12
Figure 10: THD vs. output power	12
Figure 11: THD vs. frequency	12
Figure 12: PowerSSO-36 EPU package outline	15

1 Device block diagram

The figure below shows the block diagram of one of the two identical channels of the TDA7498E.

Figure 1: Internal block diagram (showing one channel only)

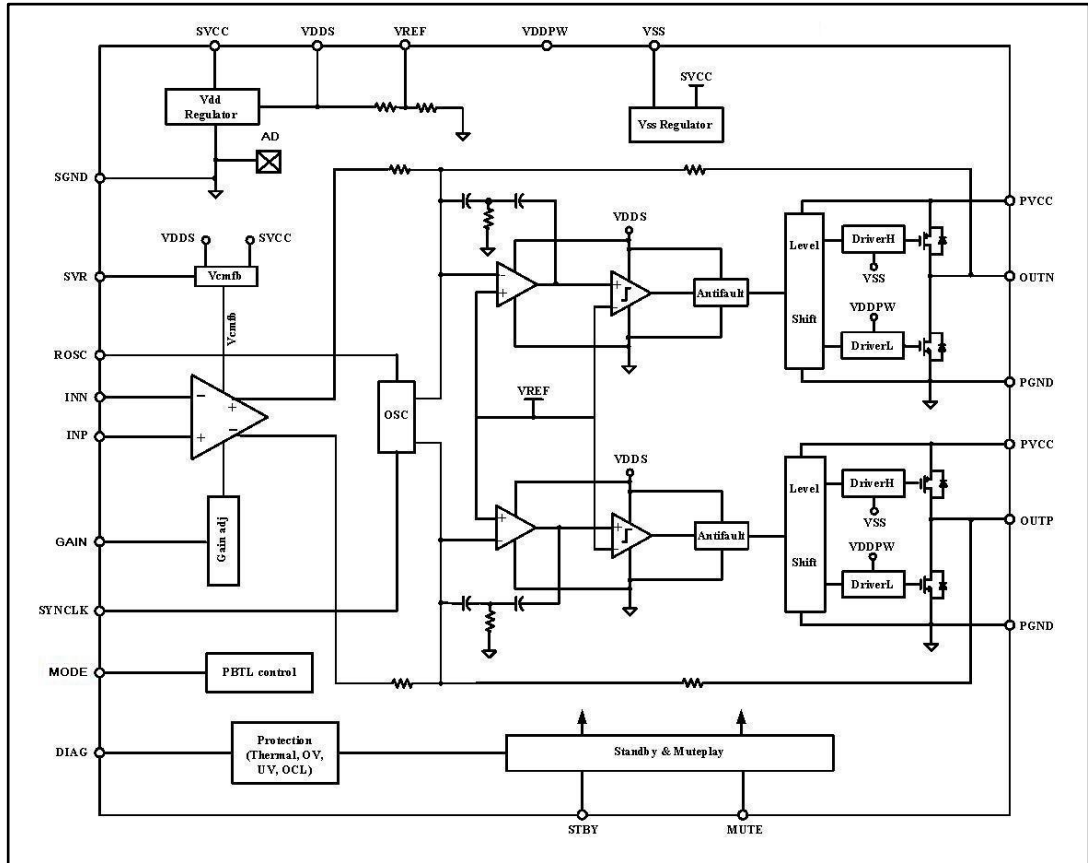

2 Pin description

2.1 Pinout

Figure 2: Pin connections (top view, PCB view)

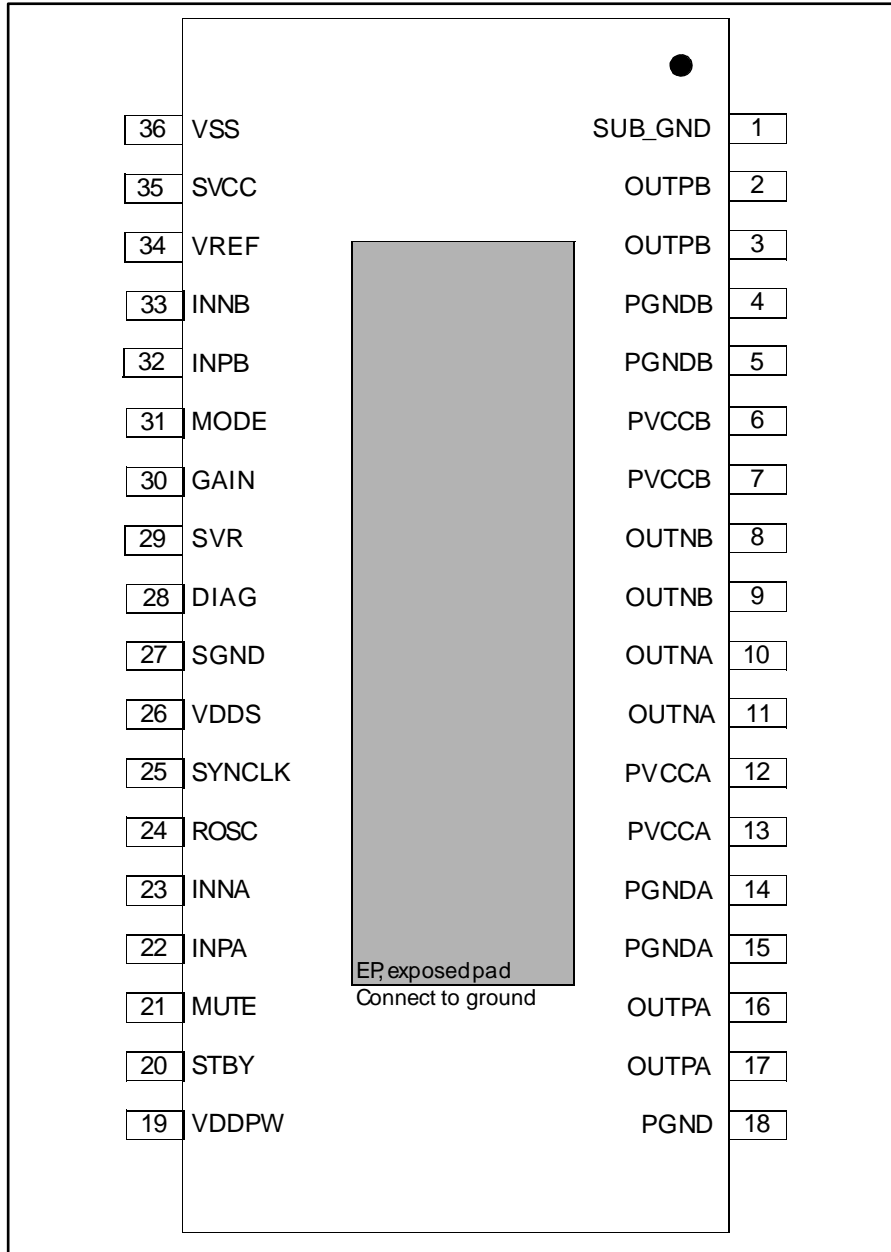

2.3 Pin list

Table 2: Pin description list

Number	Name	Type	Description
1	SUB_GND	PWR	Connect to the frame
2,3	OUTPB	O	Positive PWM for right channel
4,5	PGNDB	PWR	Power stage ground for right channel
6,7	PVCCB	PWR	Power supply for right channel
8,9	OUTNB	O	Negative PWM output for right channel
10,11	OUTNA	O	Negative PWM output for left channel
12,13	PVCCA	PWR	Power supply for left channel
14,15	PGNDA	PWR	Power stage ground for left channel
16,17	OUTPA	O	Positive PWM output for left channel
18	PGND	PWR	Power stage ground
19	VDDPW	O	3.3-V (nominal) regulator output referred to ground for power stage
20	STBY	I	Standby mode control
21	MUTE	I	Mute mode control
22	INPA	I	Positive differential input of left channel
23	INNA	I	Negative differential input of left channel
24	ROSC	O	Master oscillator frequency-setting pin
25	SYNCLK	I/O	Clock in/out for external oscillator
26	VDDS	O	3.3-V (nominal) regulator output referred to ground for signal blocks
27	SGND	PWR	Signal ground
28	DIAG	O	Open-drain diagnostic output
29	SVR	O	Supply voltage rejection
30	GAIN	I	Gain setting input
31	MODE	I	Enables stereo or mono BTL mode of operation
32	INPB	I	Positive differential input of right channel
33	INNBN	I	Negative differential input of right channel
34	VREF	O	Half VDDS (nominal) referred to ground
35	SVCC	PWR	Signal power supply
36	VSS	O	3.3-V (nominal) regulator output referred to power supply
-	EP	-	Exposed pad for heatsink, to be connected to ground

3 Electrical specifications

3.1 Absolute maximum ratings

Table 3: Absolute maximum ratings

Symbol	Parameter	Value	Unit
V _{CC}	DC supply voltage for pins PVCCA, PVCCB, SVCC	45	V
V _I	Voltage limits for input pins STBY, MUTE, INNA, INPA, INN, INPB, GAIN, MODE	-0.3 to 4.0	V
T _j	Operating junction temperature	0 to 150	°C
T _{op}	Operating ambient temperature	0 to 70	°C
T _{stg}	Storage temperature	-40 to 150	°C

3.2 Thermal data

Table 4: Thermal data

Symbol	Parameter	Min	Typ	Max	Unit
R _{th j-case}	Thermal resistance, junction to case	-	3.0		°C/W

3.3 Recommended operating conditions

Table 5: Recommended operating conditions

Symbol	Parameter	Min	Typ	Max	Unit
V _{CC}	Supply voltage for pins PVCCA, PVCCB, SVCC	14	-	39	V
T _{amb}	Ambient operating temperature	0	-	70	°C

3.4 Electrical specifications

Unless otherwise stated, the values in the table below are specified for the conditions:
V_{CC} = 36 V, R_L = 4 Ω, R_{OSC} = R3 = 39 kΩ, C8 = 100 nF, f = 1 kHz, G_V = 23.6 dB
T_{amb} = 25 °C.

Table 6: Electrical specifications

Symbol	Parameter	Condition	Min	Typ	Max	Unit
I _q	Total quiescent current	No LC filter, no load	-	60		mA
I _{qSTBY}	Quiescent current in standby	-	-	1		μA
V _{OS}	Output offset voltage	V _i = 0, A _v = 23.6 dB, no load	-20	-	20	mV
I _{oCP}	Overcurrent protection threshold	R _L = 0 Ω	10	11	14	A
T _j	Junction temperature at thermal shutdown	-	140	150	160	°C
R _i	Input resistance	Differential input		69	-	kΩ

Symbol	Parameter	Condition	Min	Typ	Max	Unit
V_{UVP}	Undervoltage protection threshold	-	-	-	8	V
R_{dsON}	Power transistor on-resistance	High side	-	0.15	-	Ω
		Low side	-	0.15	-	
P_o	Output power	THD = 10%	-	160	-	W
		THD = 1%	-	125	-	
P_o	Parallel BTL (mono) output power, $R_L = 3 \text{ ohm}$, $V_{\text{CC}} = 36 \text{ V}$	THD = 10%	-	220	-	W
		THD = 1%	-	170	-	
η	Efficiency		-	85	-	%
THD	Total harmonic distortion	$P_o = 1 \text{ W}$	-	0.05	-	%
G_V	Closed-loop gain	$\text{GAIN} < 0.25 \cdot V_{\text{DD}}$		23.8		dB
		$0.25 \cdot V_{\text{DD}} < \text{GAIN} < 0.5 \cdot V_{\text{DD}}$		29.8		
		$0.5 \cdot V_{\text{DD}} < \text{GAIN} < 0.75 \cdot V_{\text{DD}}$		33.3		
		$\text{GAIN} > 0.75 \cdot V_{\text{DD}}$		35.8		
ΔG_V	Gain matching	-	-1	-	1	dB
C_T	Crosstalk	$f = 1 \text{ kHz}$, $P_o = 1 \text{ W}$	50	60	-	dB
V_n	Total output noise	Inputs shorted and to ground, A Curve		231		μV
		Inputs shorted and to ground, $f = 20 \text{ Hz}$ to 20 kHz		400		
SVRR	Supply voltage rejection ratio	$f_r = 100 \text{ Hz}$, $V_r = 0.5 \text{ Vpp}$, $C_{\text{SVR}} = 10 \mu\text{F}$	-	55	-	dB
T_r, T_f	Rise and fall times	-	-	35	-	ns
f_{SW}	Switching frequency	Internal oscillator	240	310	400	kHz
f_{SWR}	Output switching frequency range	With internal oscillator by changing $R_{\text{OSC}}^{(1)}$	240	-		kHz
V_{inH}	Digital input high (H)	-	2.0	-	-	V
V_{inL}	Digital input low (L)		-	-	0.8	
Function mode	Standby & mute & play	$\text{STBY} < 0.5 \text{ V}$; $\text{MUTE} = \text{X}$	Standby			
		$\text{STBY} > 2.5 \text{ V}$; $\text{MUTE} < \text{L}$	Mute			
		$\text{STBY} > 2.5 \text{ V}$; $\text{MUTE} > \text{H}$	Play			
A_{MUTE}	Mute attenuation	$V_{\text{MUTE}} < \text{L}$, $V_{\text{STBY}} = \text{H}$	-	75	-	dB

Notes:

⁽¹⁾ $f_{\text{SW}} = 10^6 / ((16 \cdot R_{\text{OSC}} + 182) \cdot 4) \text{ kHz}$, $f_{\text{SYNCLK}} = 2 \cdot f_{\text{SW}}$ with $R_3 = 39 \text{ k}\Omega$ (see [Figure 3: "Test circuit stereo application and mono BTL mode"](#)).

3.5 Test circuit

Figure 3: Test circuit stereo application and mono BTL mode

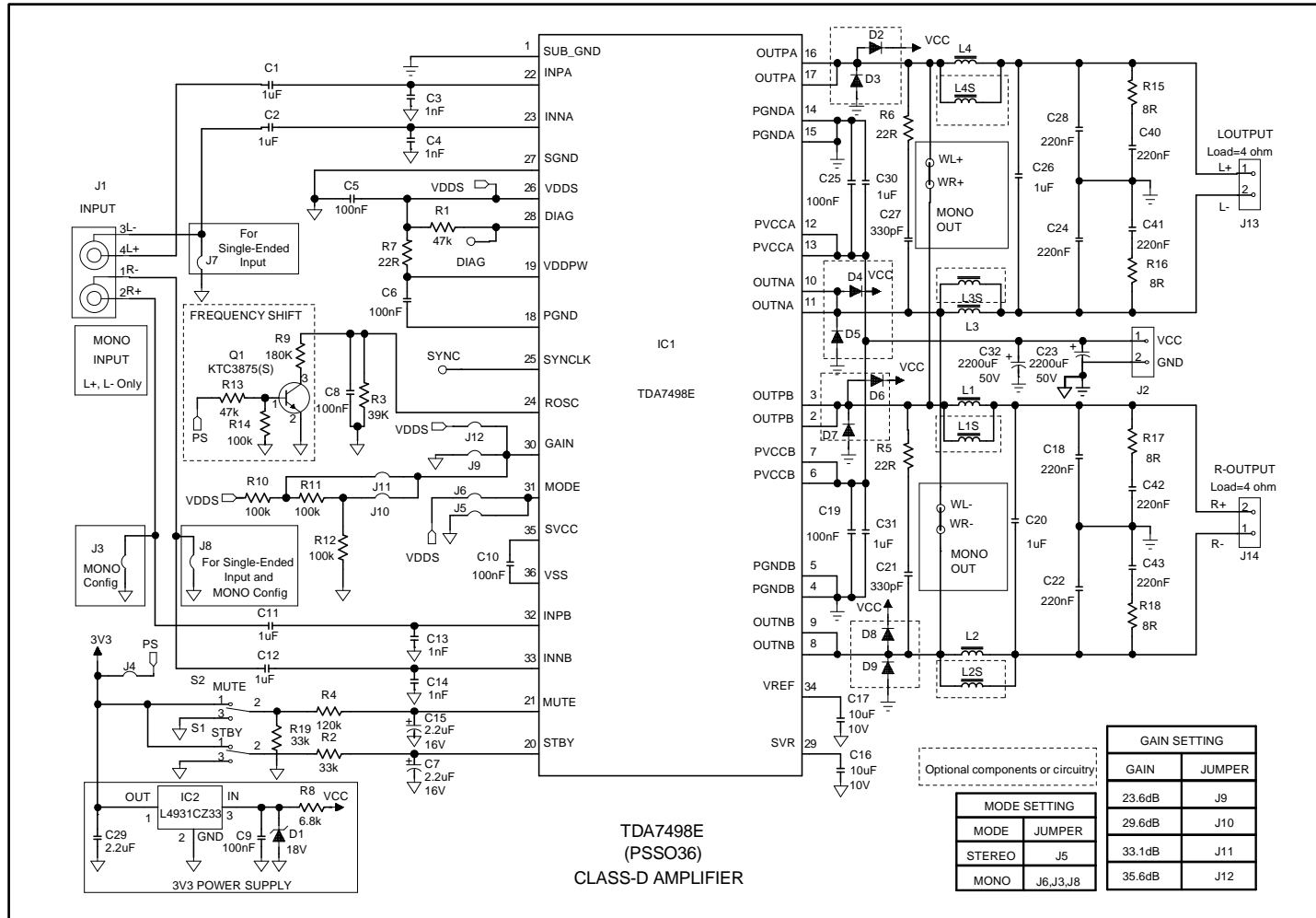

4 Characterization curves

Unless otherwise stated the measurements were made under the following conditions:

$V_{CC} = 36\text{ V}$, $f = 1\text{ kHz}$, $G_V = 23.6\text{ dB}$, $R_{OSC} = 39\text{ k}\Omega$, $C_{OSC} = 100\text{ nF}$, $T_{amb} = 25\text{ }^\circ\text{C}$

4.1 For $R_L = 4\ \Omega$, stereo configuration

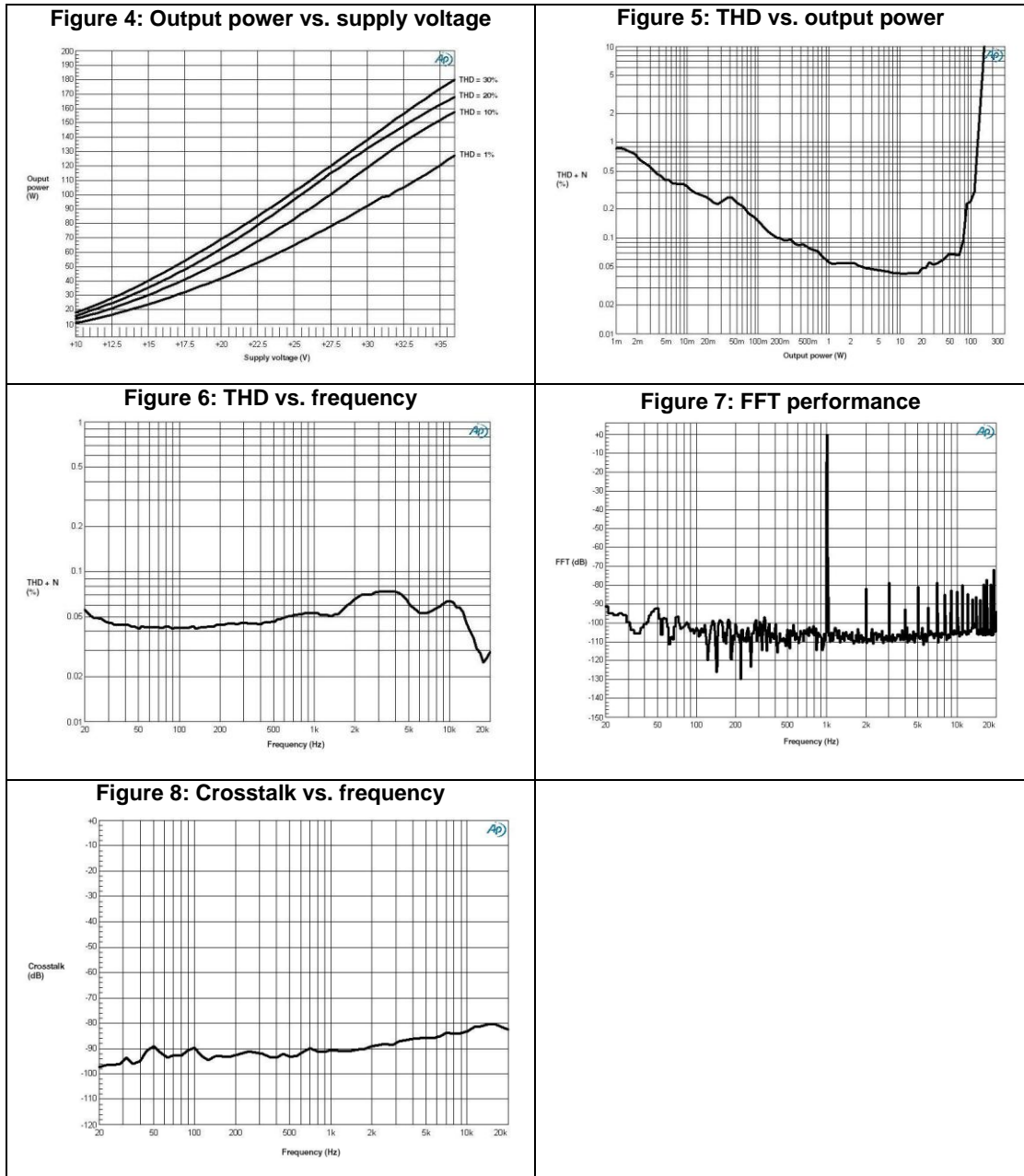

4.3 For $R_L = 3 \Omega$, mono BTL configuration

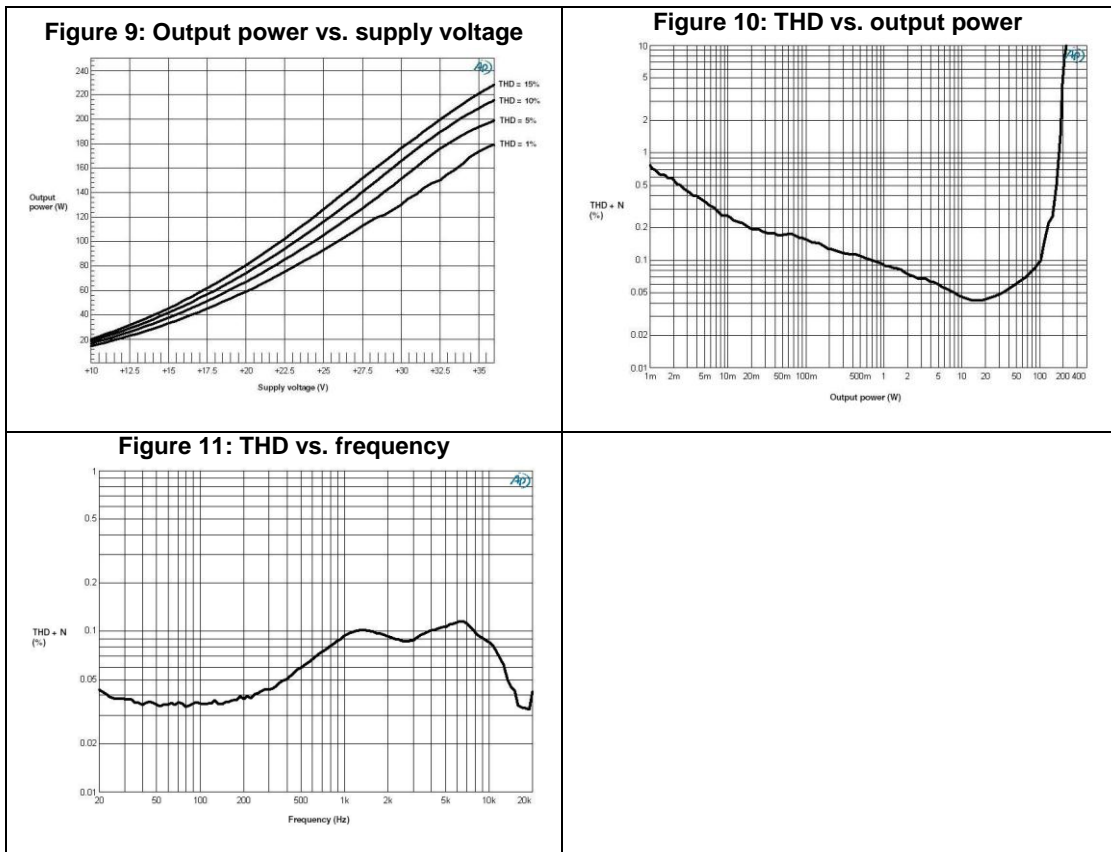

5 Application information

5.1 Stereo and mono BTL operation selection using the MODE pin

The TDA7498E can be used in stereo applications or mono BTL applications. Connecting the MODE pin to the VDDS pin configures the device in mono BTL. The output of the two channels can be paralleled. When the MODE pin is connected to ground or floating (pulled down internally) the device works as a stereo amplifier.

5.2 Gain setting

The gain of the TDA7498E is set by GAIN (pin 30).

Table 7: Gain settings

GAIN	Total gain	Application recommendation
$VGAIN < 0.25 \cdot VDDS$	23.6 dB	GAIN pin connected to SGND
$0.25 \cdot VDDS < VGAIN < 0.5 \cdot VDDS$	29.6 dB	Rc10 = Rc11 = Rc12 = 100 K max
$0.5 \cdot VDDS < VGAIN < 0.75 \cdot VDDS$	33.1 dB	Rc10 = Rc11 = Rc12 = 100 K max
$VGAIN > 0.75 \cdot VDDS$	35.6 dB	GAIN pin connected to VDDS

5.3 Smart protection

The TDA7498E embeds an overcurrent protection circuitry to protect the device from unwanted current peaks. If the overcurrent protection threshold ([Table 6: "Electrical specifications"](#)) is exceeded, the power stage will be shut down immediately. The device will recover automatically once the fault is removed.

6 Package information

In order to meet environmental requirements, ST offers these devices in different grades of ECOPACK[®] packages, depending on their level of environmental compliance. ECOPACK[®] specifications, grade definitions and product status are available at: www.st.com. ECOPACK[®] is an ST trademark.

6.1 PowerSSO-36 EPU package information

The TDA7492E comes in a 36-pin PowerSSO package with exposed pad up (EPU).

Figure 12: "PowerSSO-36 EPU package outline" shows the package outline and *Table 8: "PowerSSO-36 EPU package mechanical data"* gives the dimensions.

Figure 12: PowerSSO-36 EPU package outline

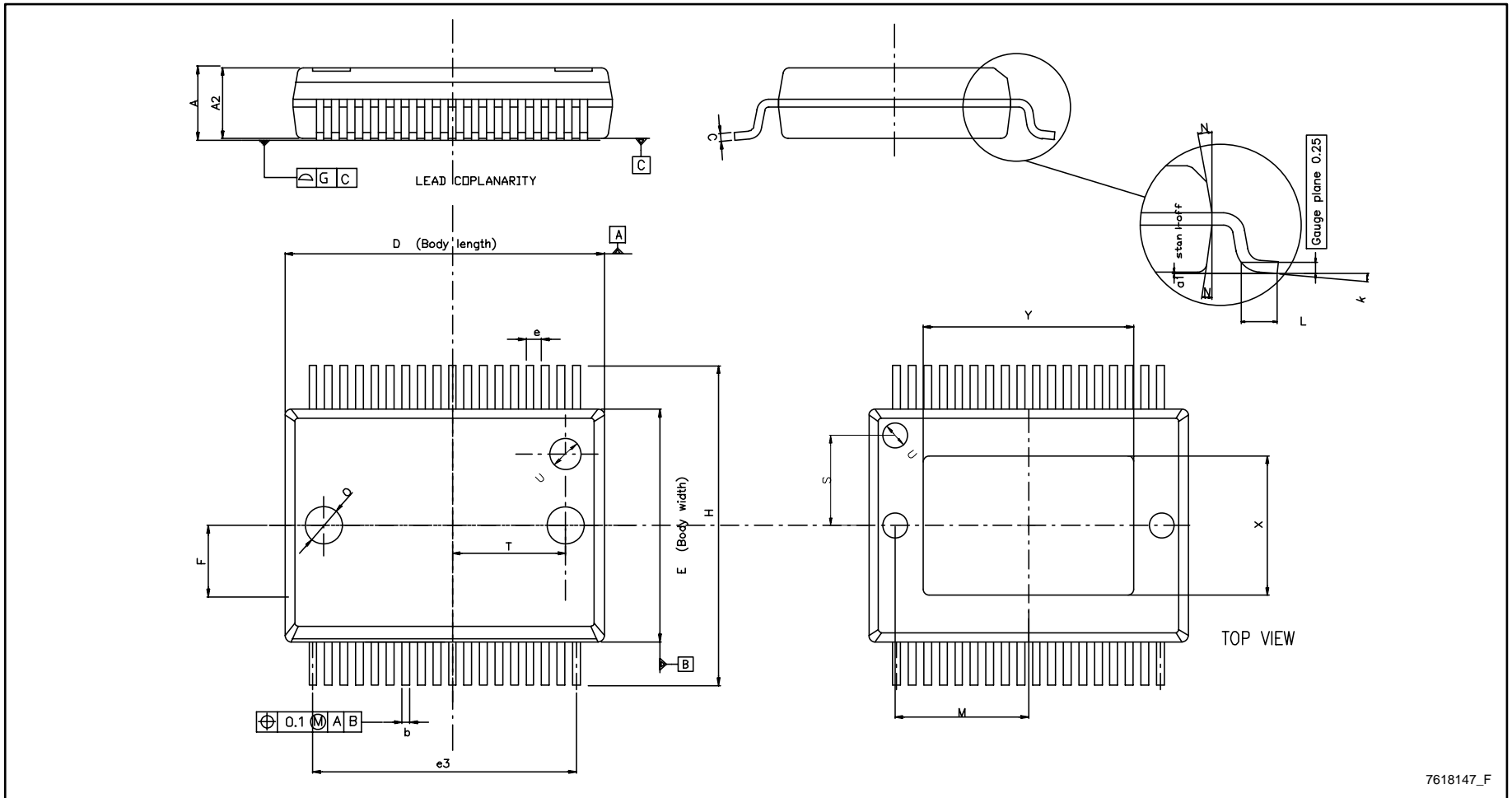

7618147_F

Table 8: PowerSSO-36 EPU package mechanical data

Symbol	Dimensions in mm			Dimensions in inches		
	Min.	Typ.	Max.	Min.	Typ.	Max.
A	2.15	-	2.45	0.085	-	0.096
A2	2.15	-	2.35	0.085	-	0.093
a1	0	-	0.10	0	-	0.004
b	0.18	-	0.36	0.007	-	0.014
c	0.23	-	0.32	0.009	-	0.013
D	10.10	-	10.50	0.398	-	0.413
E	7.40	-	7.60	0.291	-	0.299
e	-	0.5	-	-	0.020	-
e3	-	8.5	-	-	0.335	-
F	-	2.3	-	-	0.091	-
G	-	-	0.10	-	-	0.004
H	10.10	-	10.50	0.398	-	0.413
h	-	-	0.40	-	-	0.016
k	0	-	8 degrees	0	-	8 degrees
L	0.55	-	0.85	0.022	-	0.033
M	-	4.30	-	-	0.169	-
N	-	-	10 degrees	-	-	10 degrees
O	-	1.20	-	-	0.047	-
Q	-	0.80	-	-	0.031	-
S	-	2.90	-	-	0.114	-
T	-	3.65	-	-	0.144	-
U	-	1.00	-	-	0.039	-
X	4.10	-	4.70	0.161	-	0.185
Y	4.90	-	7.10	0.193	-	0.280

7 Revision history

Table 9: Document revision history

Date	Revision	Changes
12-Dec-2011	1	Initial release.
16-Jun-2015	2	Updated V_{CC} in Table 3: "Absolute maximum ratings" , updated Section 6.3: "Smart protection" , and updated dimension L in Table 8: "PowerSSO-36 EPU package mechanical data" .

IMPORTANT NOTICE – PLEASE READ CAREFULLY

STMicroelectronics NV and its subsidiaries ("ST") reserve the right to make changes, corrections, enhancements, modifications, and improvements to ST products and/or to this document at any time without notice. Purchasers should obtain the latest relevant information on ST products before placing orders. ST products are sold pursuant to ST's terms and conditions of sale in place at the time of order acknowledgement.

Purchasers are solely responsible for the choice, selection, and use of ST products and ST assumes no liability for application assistance or the design of Purchasers' products.

No license, express or implied, to any intellectual property right is granted by ST herein.

Resale of ST products with provisions different from the information set forth herein shall void any warranty granted by ST for such product.



ST and the ST logo are trademarks of ST. All other product or service names are the property of their respective owners.

Information in this document supersedes and replaces information previously supplied in any prior versions of this document.

© 2015 STMicroelectronics – All rights reserved

Looking for pricing, stock, or lifecycle information?

Click below to explore more details on WIN SOURCE:

-  [View TDA7498E on WIN SOURCE](#)
-  [STMicroelectronics Information](#)

Optimize Your Supply Chain with WIN SOURCE Solutions

-  Global Sourcing Solution
-  Obsolete Management
-  Cost Control Management
-  Shortage Management
-  Alternative Solution
-  Excess Inventory Management