

Serial-in / Parallel-out Driver Series

# Serial-Parallel 3-input Driver



BA823F

No.09051EAT01

●Description

BA823F are an 8-bit serial-to-parallel-output driver, applicable for thermal printer heads or LED character display drivers.

●Features

- 1) Capable of driving a maximum of 200mA.
- 2) Non-driving current consumption can be reduced by controlling the strobe timing pulse.
- 3) Output data terminal can be used for a cascade configuration.
- 4) Digital ground and power ground are separated.
- 5) TTL and CMOS allow driving.

●Applications

Driver for thermal print head  
Driver for LED character display

●Absolute maximum ratings (Ta=25°C)

Parameter	Symbol	Limits	Unit
Power supply voltage	Vcc	7.0* <sup>1</sup>	V
Power dissipation	BA823F Pd	500* <sup>3</sup>	mW
Input voltage	VIN MAX	+0.3 to +6.0	V
Operating temperature	Topr	-20 to +75	°C
Storage temperature	Tstg	-55 to +125	°C

\*1 Voltage of  $\overline{O}_0\sim\overline{O}_7$  terminals is 34V (Max.)

\*2 Reduced by 5.5 mW/°C over 25°C.

\*3 Reduced by 5.0 mW/°C over 25°C.

●Thermal derating curve

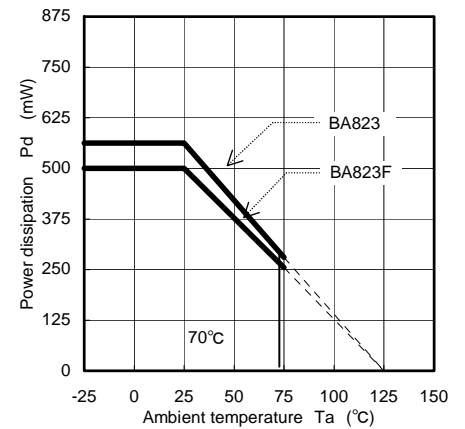

Fig.1

● **Electrical characteristics** (Unless otherwise specified,  $T_a=25^\circ\text{C}$ ,  $V_{cc}=+5.0\text{V}$ )

Parameter	Symbol	Min.	Typ.	Max.	Unit	Conditions	Test Circuit
Power supply	$V_{CC}$	4.5	5.0	5.5	V	$V_{CC}$ terminal	Fig.2
Current dissipation(no load)1	$I_{O1}$	-	4	6	mA	@All outputs = "0"	Fig.2
Current dissipation(no load)2	$I_{O2}$	-	8	11	mA	@All outputs = "0"	Fig.2
Input low level voltage	$V_{IL}$	-	-	0.8	V	-	Fig.2
Input high level voltage	$V_{IH}$	2	-	-	V	-	Fig.2
Input low level current	$I_{IL}$	-	-	0.4	mA	$V_{IN}=4.5\text{V}$	Fig.2
Input high level current	$I_{IH}$	-	-	100	$\mu\text{A}$	$V_{IN}=2.0\text{V}$	Fig.3
Maximum output voltage	$V_{O\ OFF}$	-	-	21.8	V	$\bar{O} 0$ to $\bar{O} 7$ , $I_o=10\mu\text{A}$	Fig.3
Output saturation voltage	$V_{O\ ON}$	-	0.8	1.3	V	@ $I_o=100\text{mA}$ sink	Fig.3
Output current	$I_{OL}$	-	-	207	mA	External voltage = 11.8V	Fig.3
"H" output voltage	$V_{DOH}$	2.4	-	-	V	$R_L=10\text{k}\Omega$	Fig.3
"L" output voltage	$V_{DOL}$	-	-	0.8	V	-	Fig.3
Minimum set up time	$t_1$	-	-	300	ns	$V_{IH}=2.0\text{V}$ , $V_{IL}=0.8\text{V}$	-
Minimum shift clock width	$T_2$	-	-	1	$\mu\text{s}$	$V_{IH}=2.0\text{V}$ , $V_{IL}=0.8\text{V}$	-
Minimum timing pulse width	$T_3$	-	-	1	$\mu\text{s}$	$V_{IH}=2.0\text{V}$ , $V_{IL}=0.8\text{V}$	-
Maximum transfer time	$f_{Max}$	500	-	-	kHz	$V_{IH}=2.0\text{V}$ , $V_{IL}=0.8\text{V}$	-

● **Usage conditions range**

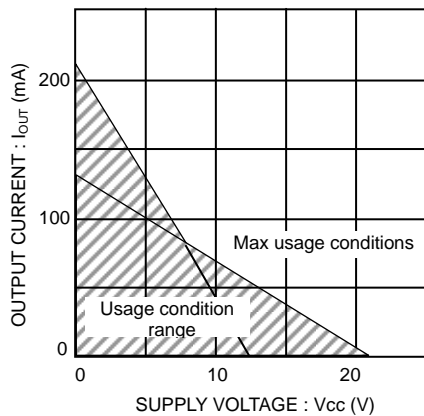
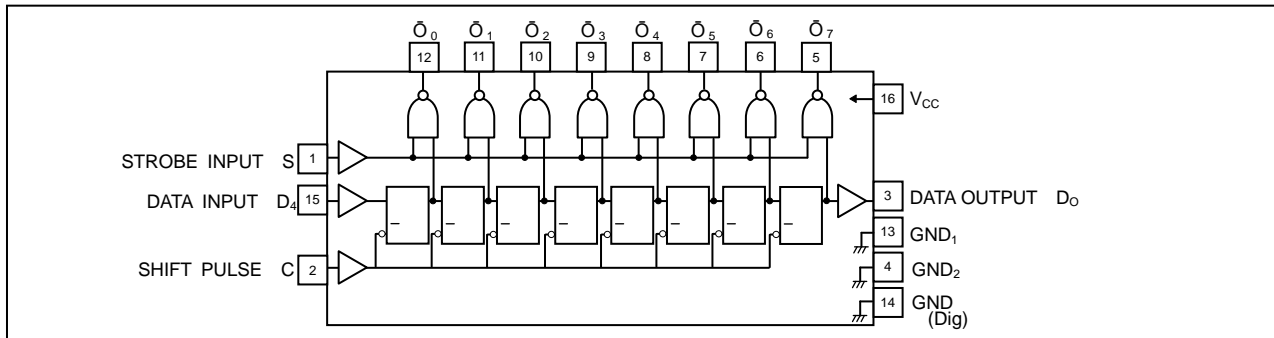

Fig.2: Conditions to use supply voltage and output current (per circuit)  
 Maximum conditions of use in the diagram to the left, show the absolute maximum supply voltage and IC output current.  
 This product should not exceed the usage conditions range.

Fig.2 Power supply voltage and current usage conditions

### ●Block diagram



### ●Pin descriptions

Pin No.	Pin Name	Symbol	Function
2	SHIFT PULSE	C	Shift pulse of shift register
15	DATA INPUT	D1	Data input of shift register is stored during the shift pulse rise time.
1	STROBE	S	When "1" is effective, the content of shift register is outputted.
12	OUTPUT	$\bar{O}_0$	"0" is effective when the content of register is "1" on the 1st bit is outputted.
11	OUTPUT	$\bar{O}_1$	"0" is effective when the content of register is "1" on the 2nd bit is outputted.
10	OUTPUT	$\bar{O}_2$	"0" is effective when the content of register is "1" on the 3rd bit is outputted.
9	OUTPUT	$\bar{O}_3$	"0" is effective when the content of register is "1" on the 4th bit is outputted.
8	OUTPUT	$\bar{O}_4$	"0" is effective when the content of register is "1" on the 5th bit is outputted.
7	OUTPUT	$\bar{O}_5$	"0" is effective when the content of register is "1" on the 6th bit is outputted.
6	OUTPUT	$\bar{O}_6$	"0" is effective when the content of register is "1" on the 7th bit is outputted.
5	OUTPUT	$\bar{O}_7$	"0" is effective when the content of register is "1" on the 8th bit is outputted.
3	DATA OUTPUT	D0	Data having passed through the output circuit of $\bar{O}_7$ becomes the input of the next stage
16	Vcc	Vcc	5.0V .is used normally ( $\pm 10\%$ )
13	GND	GND1	Especially, GND of the output circuit of $\bar{O}_0 \sim \bar{O}_3$
4	GND	GND2	Especially, GND of the output circuit of $\bar{O}_4 \sim \bar{O}_7$
14	GND	GND(Dig)	Especially, GND of the logic circuit

### ●Description of operation

BA823 is configured internally as shown in the block diagram. Terminals of clock C, data D1, and strobe S are used as input. Data input is synchronized with the clock, read serially during the rise time and latched at the rise time edge of the shifted shift register. The content of the set shift register appears on the output terminal of  $\bar{O}_0 \sim \bar{O}_7$  when the strobe is input, as shown in the time chart of Fig.5. Pulse width is the same as that of the strobe input pulse.

Data output terminal D0, is a terminal used for cascade connection of the IC, where the output of the final stage of the shift register has appeared, and is connected to the next data input terminal D1. In this case, when the clock and the strobe are used in conjunction, output terminal can be increased by 8 bits at a time.

● Measurement circuits

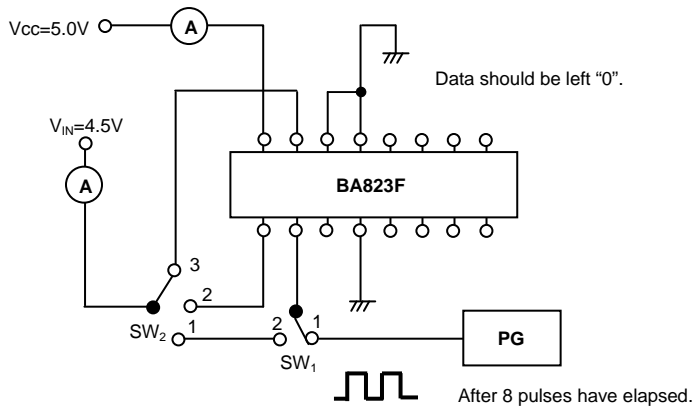

Item	SW <sub>1</sub>	SW <sub>2</sub>
I <sub>CC</sub>	1	1
I <sub>IH</sub>	2	1~3

Fig.3 Icc 1st measurement circuit

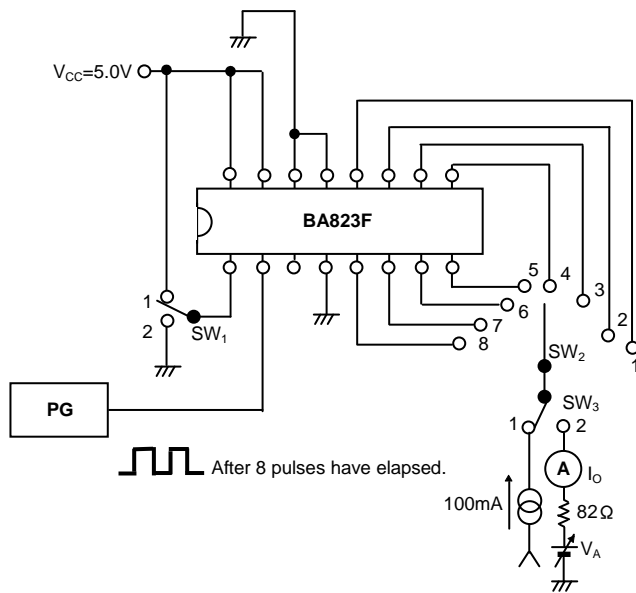

Item	SW <sub>1</sub>	SW <sub>2</sub>	SW <sub>3</sub>
VO ON	1	1~8	1
IOL	1	1~8	1
VO OFF	2	1~8	2

I<sub>O</sub> = 10μA when VO OFF is measured  
 V<sub>A</sub> = 30V when I<sub>O</sub> ON is measured

Fig.4 Vo ON, Vo OFF, IOL measurement circuit

● Input conditions

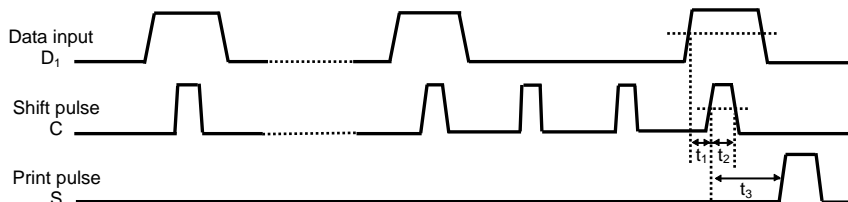

Fig.5

●Timing chart

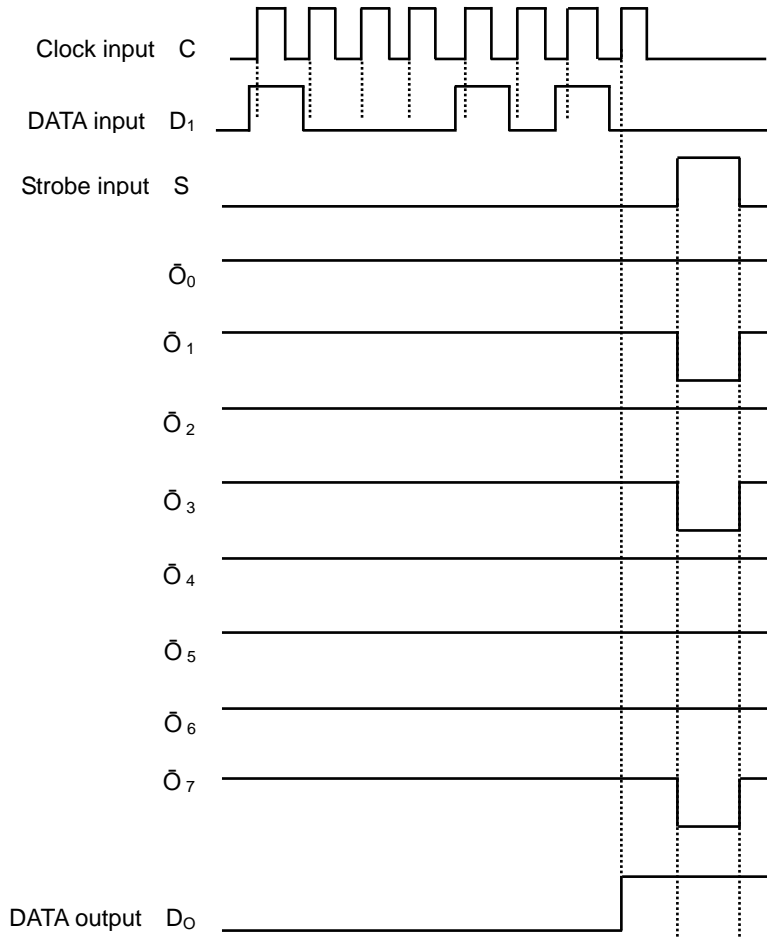

Fig.6

●Application example

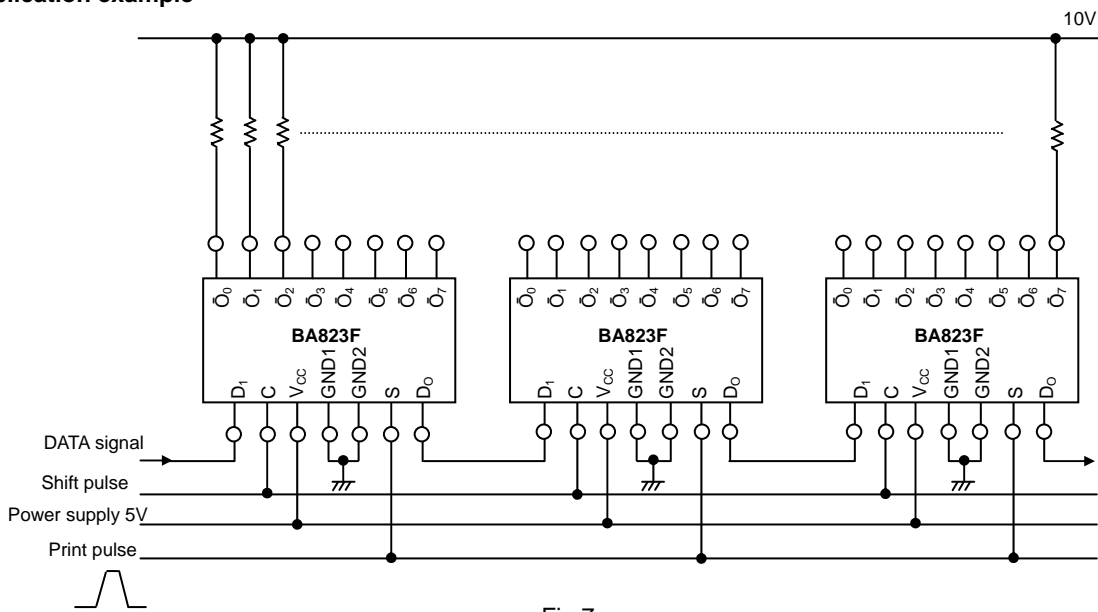

Fig.7

Example: Print head using the strobe function  
 Disabling the high current while the heating element is switched off is advantageous.

Use for thermal printer (when the timing is 1 phase) example

● Interfaces

(a) Input

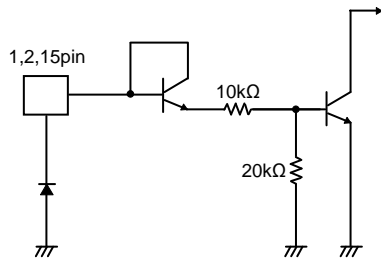

(b) Output

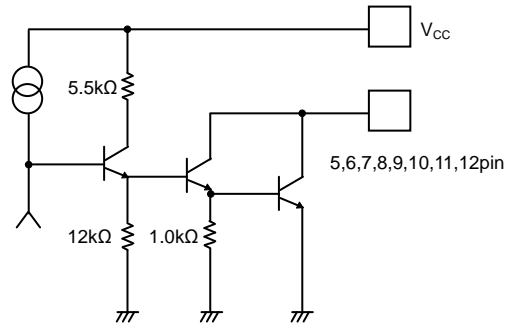

(c) Serial data output

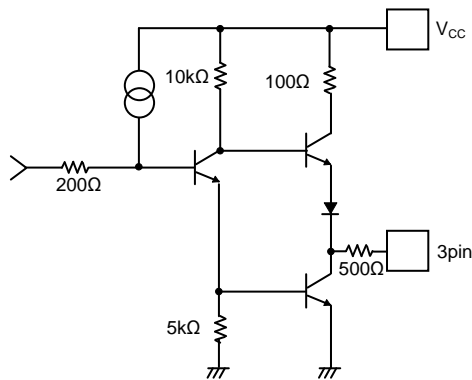
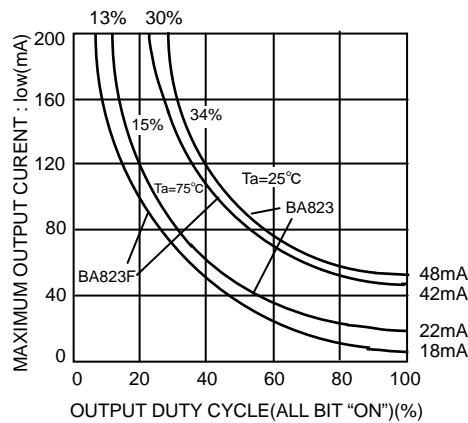

Fig.8

● Thermal derating curve



At repetition frequency 1Hz or higher

Fig.9 Output conditions

### ●Notes for use

#### 1. Absolute maximum ratings

An excess in the absolute maximum ratings, such as supply voltage, temperature range of operating conditions, etc., can break down the devices, thus making impossible to identify breaking mode, such as a short circuit or an open circuit. If any over rated values will expect to exceed the absolute maximum ratings, consider adding circuit protection devices, such as fuses.

#### 2. Connecting the power supply connector backward

Connecting of the power supply in reverse polarity can damage IC. Take precautions when connecting the power supply lines. An external direction diode can be added.

#### 3. Power supply lines

Design PCB layout pattern to provide low impedance GND and supply lines. To obtain a low noise ground and supply line, separate the ground section and supply lines of the digital and analog blocks. Furthermore, for all power supply terminals to ICs, connect a capacitor between the power supply and the GND terminal. When applying electrolytic capacitors in the circuit, not that capacitance characteristic values are reduced at low temperatures.

#### 4. GND voltage

The potential of GND pin must be minimum potential in all operating conditions.

#### 5. Inter-pin shorts and mounting errors

Use caution when positioning the IC for mounting on printed circuit boards. The IC may be damaged if there is any connection error or if pins are shorted together.

#### 6. Actions in strong electromagnetic field

Use caution when using the IC in the presence of a strong electromagnetic field as doing so may cause the IC to malfunction.

#### 7. Testing on application boards

When testing the IC on an application board, connecting a capacitor to a pin with low impedance subjects the IC to stress. Always discharge capacitors after each process or step. Always turn the IC's power supply off before connecting it to or removing it from a jig or fixture during the inspection process. Ground the IC during assembly steps as an antistatic measure. Use similar precaution when transporting or storing the IC.

#### 8. Regarding input pin of the IC

This monolithic IC contains P+ isolation and P substrate layers between adjacent elements in order to keep them isolated. P-N junctions are formed at the intersection of these P layers with the N layers of other elements, creating a parasitic diode or transistor. For example, the relation between each potential is as follows:

When  $GND > Pin A$  and  $GND > Pin B$ , the P-N junction operates as a parasitic diode.

When  $GND > Pin B$ , the P-N junction operates as a parasitic transistor.

Parasitic diodes can occur inevitable in the structure of the IC. The operation of parasitic diodes can result in mutual interference among circuits, operational faults, or physical damage. Accordingly, methods by which parasitic diodes operate, such as applying a voltage that is lower than the GND (P substrate) voltage to an input pin, should not be used.

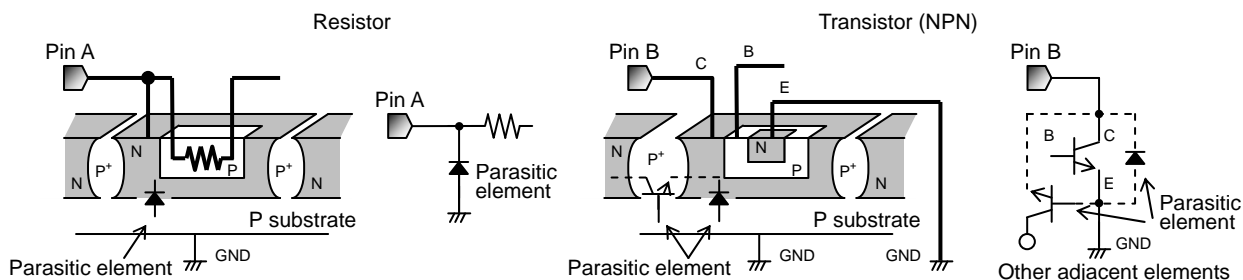

Fig.10 Example of IC structure

#### 9. Ground Wiring Pattern

When using both small signal and large current GND patterns, it is recommended to isolate the two ground patterns, placing a single ground point at the ground potential of application so that the pattern wiring resistance and voltage variations caused by large currents do not cause variations in the small signal ground voltage. Be careful not to change the GND wiring pattern of any external components, either.

●Ordering part number

B	D
---	---

Part No.

8	2	3
---	---	---

Part No.

F
---

Package  
F: SOP16

E	2
---	---

Packaging and forming specification  
E2: Embossed tape and reel

SOP16

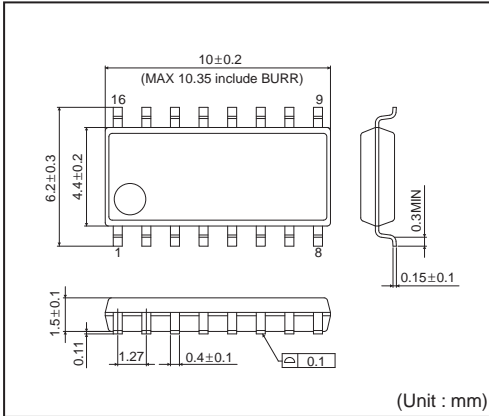

<Tape and Reel information>

Tape	Embossed carrier tape
Quantity	2500pcs
Direction of feed	E2 ( The direction is the 1 pin of product is at the upper left when you hold reel on the left hand and you pull out the tape on the right hand )

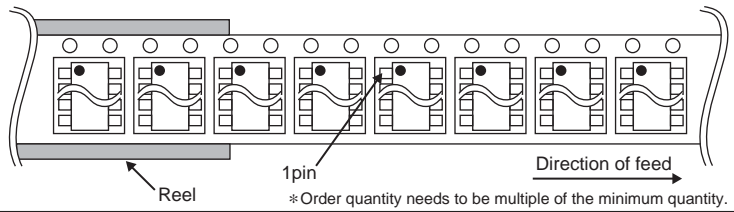

# Notice

## Precaution on using ROHM Products

- Our Products are designed and manufactured for application in ordinary electronic equipments (such as AV equipment, OA equipment, telecommunication equipment, home electronic appliances, amusement equipment, etc.). If you intend to use our Products in devices requiring extremely high reliability (such as medical equipment <sup>(Note 1)</sup>, transport equipment, traffic equipment, aircraft/spacecraft, nuclear power controllers, fuel controllers, car equipment including car accessories, safety devices, etc.) and whose malfunction or failure may cause loss of human life, bodily injury or serious damage to property ("Specific Applications"), please consult with the ROHM sales representative in advance. Unless otherwise agreed in writing by ROHM in advance, ROHM shall not be in any way responsible or liable for any damages, expenses or losses incurred by you or third parties arising from the use of any ROHM's Products for Specific Applications.

(Note1) Medical Equipment Classification of the Specific Applications

JAPAN	USA	EU	CHINA
CLASS III	CLASS III	CLASS II b	CLASS III
CLASS IV		CLASS III	

- ROHM designs and manufactures its Products subject to strict quality control system. However, semiconductor products can fail or malfunction at a certain rate. Please be sure to implement, at your own responsibilities, adequate safety measures including but not limited to fail-safe design against the physical injury, damage to any property, which a failure or malfunction of our Products may cause. The following are examples of safety measures:
  - Installation of protection circuits or other protective devices to improve system safety
  - Installation of redundant circuits to reduce the impact of single or multiple circuit failure
- Our Products are designed and manufactured for use under standard conditions and not under any special or extraordinary environments or conditions, as exemplified below. Accordingly, ROHM shall not be in any way responsible or liable for any damages, expenses or losses arising from the use of any ROHM's Products under any special or extraordinary environments or conditions. If you intend to use our Products under any special or extraordinary environments or conditions (as exemplified below), your independent verification and confirmation of product performance, reliability, etc. prior to use, must be necessary:
  - Use of our Products in any types of liquid, including water, oils, chemicals, and organic solvents
  - Use of our Products outdoors or in places where the Products are exposed to direct sunlight or dust
  - Use of our Products in places where the Products are exposed to sea wind or corrosive gases, including Cl<sub>2</sub>, H<sub>2</sub>S, NH<sub>3</sub>, SO<sub>2</sub>, and NO<sub>2</sub>
  - Use of our Products in places where the Products are exposed to static electricity or electromagnetic waves
  - Use of our Products in proximity to heat-producing components, plastic cords, or other flammable items
  - Sealing or coating our Products with resin or other coating materials
  - Use of our Products without cleaning residue of flux (even if you use no-clean type fluxes, cleaning residue of flux is recommended); or Washing our Products by using water or water-soluble cleaning agents for cleaning residue after soldering
  - Use of the Products in places subject to dew condensation
- The Products are not subject to radiation-proof design.
- Please verify and confirm characteristics of the final or mounted products in using the Products.
- In particular, if a transient load (a large amount of load applied in a short period of time, such as pulse. is applied, confirmation of performance characteristics after on-board mounting is strongly recommended. Avoid applying power exceeding normal rated power; exceeding the power rating under steady-state loading condition may negatively affect product performance and reliability.
- De-rate Power Dissipation (Pd) depending on Ambient temperature (Ta). When used in sealed area, confirm the actual ambient temperature.
- Confirm that operation temperature is within the specified range described in the product specification.
- ROHM shall not be in any way responsible or liable for failure induced under deviant condition from what is defined in this document.

## Precaution for Mounting / Circuit board design

- When a highly active halogenous (chlorine, bromine, etc.) flux is used, the residue of flux may negatively affect product performance and reliability.
- In principle, the reflow soldering method must be used; if flow soldering method is preferred, please consult with the ROHM representative in advance.

For details, please refer to ROHM Mounting specification

**Precautions Regarding Application Examples and External Circuits**

1. If change is made to the constant of an external circuit, please allow a sufficient margin considering variations of the characteristics of the Products and external components, including transient characteristics, as well as static characteristics.
2. You agree that application notes, reference designs, and associated data and information contained in this document are presented only as guidance for Products use. Therefore, in case you use such information, you are solely responsible for it and you must exercise your own independent verification and judgment in the use of such information contained in this document. ROHM shall not be in any way responsible or liable for any damages, expenses or losses incurred by you or third parties arising from the use of such information.

**Precaution for Electrostatic**

This Product is electrostatic sensitive product, which may be damaged due to electrostatic discharge. Please take proper caution in your manufacturing process and storage so that voltage exceeding the Products maximum rating will not be applied to Products. Please take special care under dry condition (e.g. Grounding of human body / equipment / solder iron, isolation from charged objects, setting of ionizer, friction prevention and temperature / humidity control).

**Precaution for Storage / Transportation**

1. Product performance and soldered connections may deteriorate if the Products are stored in the places where:
  - [a] the Products are exposed to sea winds or corrosive gases, including Cl<sub>2</sub>, H<sub>2</sub>S, NH<sub>3</sub>, SO<sub>2</sub>, and NO<sub>2</sub>
  - [b] the temperature or humidity exceeds those recommended by ROHM
  - [c] the Products are exposed to direct sunshine or condensation
  - [d] the Products are exposed to high Electrostatic
2. Even under ROHM recommended storage condition, solderability of products out of recommended storage time period may be degraded. It is strongly recommended to confirm solderability before using Products of which storage time is exceeding the recommended storage time period.
3. Store / transport cartons in the correct direction, which is indicated on a carton with a symbol. Otherwise bent leads may occur due to excessive stress applied when dropping of a carton.
4. Use Products within the specified time after opening a humidity barrier bag. Baking is required before using Products of which storage time is exceeding the recommended storage time period.

**Precaution for Product Label**

QR code printed on ROHM Products label is for ROHM's internal use only.

**Precaution for Disposition**

When disposing Products please dispose them properly using an authorized industry waste company.

**Precaution for Foreign Exchange and Foreign Trade act**

Since our Products might fall under controlled goods prescribed by the applicable foreign exchange and foreign trade act, please consult with ROHM representative in case of export.

**Precaution Regarding Intellectual Property Rights**

1. All information and data including but not limited to application example contained in this document is for reference only. ROHM does not warrant that foregoing information or data will not infringe any intellectual property rights or any other rights of any third party regarding such information or data. ROHM shall not be in any way responsible or liable for infringement of any intellectual property rights or other damages arising from use of such information or data.:
2. No license, expressly or implied, is granted hereby under any intellectual property rights or other rights of ROHM or any third parties with respect to the information contained in this document.

**Other Precaution**

1. This document may not be reprinted or reproduced, in whole or in part, without prior written consent of ROHM.
2. The Products may not be disassembled, converted, modified, reproduced or otherwise changed without prior written consent of ROHM.
3. In no event shall you use in any way whatsoever the Products and the related technical information contained in the Products or this document for any military purposes, including but not limited to, the development of mass-destruction weapons.
4. The proper names of companies or products described in this document are trademarks or registered trademarks of ROHM, its affiliated companies or third parties.

**General Precaution**

1. Before you use our Products, you are requested to carefully read this document and fully understand its contents. ROHM shall not be in any way responsible or liable for failure, malfunction or accident arising from the use of any ROHM's Products against warning, caution or note contained in this document.
2. All information contained in this document is current as of the issuing date and subject to change without any prior notice. Before purchasing or using ROHM's Products, please confirm the latest information with a ROHM sales representative.
3. The information contained in this document is provided on an "as is" basis and ROHM does not warrant that all information contained in this document is accurate and/or error-free. ROHM shall not be in any way responsible or liable for any damages, expenses or losses incurred by you or third parties resulting from inaccuracy or errors of or concerning such information.

## Looking for pricing, stock, or lifecycle information?

Click below to explore more details on WIN SOURCE:

- [View BA823F-E2 on WIN SOURCE](#)
- [Rohm Semiconductor Information](#)

## Optimize Your Supply Chain with WIN SOURCE Solutions

- ✓ Global Sourcing Solution
- ✓ Obsolete Management
- ✓ Cost Control Management
- ✓ Shortage Management
- ✓ Alternative Solution
- ✓ Excess Inventory Management