



**THE DATASHEET OF  
BA823**



# 8-bit, serial IN, parallel OUT driver

## BA823 / BA823F

The BA823 and BA823F are 8-bit serial input, parallel output drivers. These monolithic ICs were developed as drivers for thermal printing heads, LED character displays, and other similar applications.

●Applications

Thermal printing head drivers  
LED character display drivers

●Features

- 1) Can drive up to 200 mA.
- 2) Controlling the strobe terminal with the drive timing pulse enables current to be reduced when drive is not being carried out.
- 3) Using the data output terminal for the next data input enables cascade connections.
- 4) The digital ground and power ground are separated.
- 5) TTL and CMOS drive possible.

●Block diagram

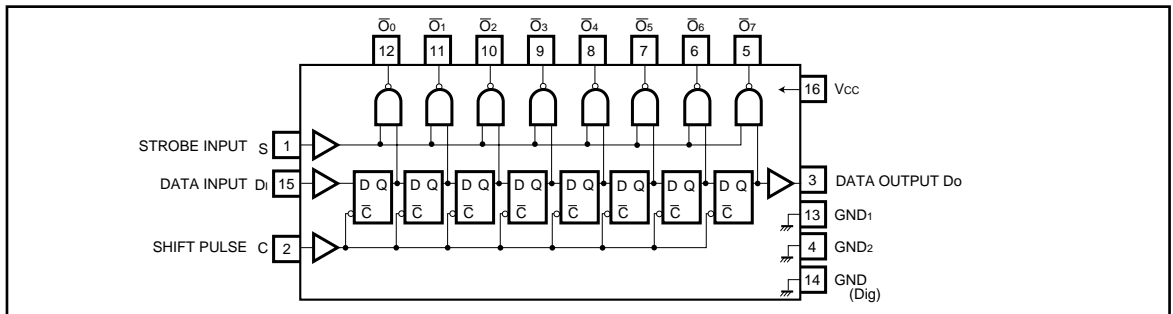

●Absolute maximum ratings (Ta = 25°C)

Parameter	Symbol	Limits	Unit
Power supply voltage	V <sub>cc</sub>	7.0*1	V
Power dissipation	BA823	550*2	mW
	BA823F		
Input voltage	V <sub>IN Max.</sub>	+ 0.3 ~ + 6.0	V
Operating temperature	Topr	- 20 ~ + 75	°C
Storage temperature	Tstg	- 55 ~ + 125	°C

\*1  $\bar{O}_0$  to  $\bar{O}_7$  output pins are 34V (max.).

\*2 Reduced by 5.5mW for each increase in Ta of 1°C over 25°C.

\*3 Reduced by 5mW for each increase in Ta of 1°C over 25°C.

● Usage conditions range

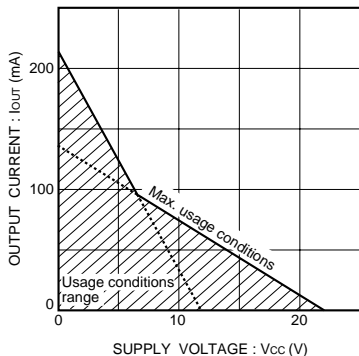

Fig. 1 Power supply voltage and output current usage conditions

Fig. 1 Power supply voltage and output current usage conditions (Per Circuit)

The maximum usage conditions, shown on the left, indicate the absolute maximums for power supply voltage and IC output current. Never exceed these usage conditions, under any circumstances.

● Electrical characteristics (unless otherwise noted, Ta = 25°C, Vcc = + 5.0V)

Parameter	Symbol	Min.	Typ.	Max.	Unit	Conditions	Measurement circuit
Power supply voltage	V <sub>CC</sub>	4.5	5.0	5.5	V	V <sub>CC</sub> pin	Fig.2
Quiescent current 1	I <sub>Q1</sub>	—	4	6	mA	When all data values are "0"	Fig.2
Quiescent current 2	I <sub>Q2</sub>	—	8	11	mA	When all data values are "0"	Fig.2
Input low level voltage	V <sub>IL</sub>	—	—	0.8	V	—	Fig.2
Input high level voltage	V <sub>IH</sub>	2	—	—	V	—	Fig.2
Input high level current	I <sub>IH</sub>	—	—	0.4	mA	V <sub>IN</sub> = 4.5 V	Fig.2
Input high level current	I <sub>IH</sub>	—	—	100	μA	V <sub>IN</sub> = 2.0 V	Fig.2
Maximum output voltage	V <sub>O OFF</sub>	—	—	21.8	V	O <sub>0</sub> to O <sub>7</sub> pins, I <sub>o</sub> = 10μA	Fig.3
Output saturation voltage	V <sub>O ON</sub>	—	0.8	1.3	V	When I <sub>o</sub> = 100mA sink	Fig.3
Output current	I <sub>OL</sub>	—	—	207	mA	Applied voltage V = 11.8V	Fig.3
"H" level data output voltage	V <sub>DOH</sub>	2.4	—	—	V	R <sub>L</sub> = 10kΩ	Fig.3
"L" level data output voltage	V <sub>DOL</sub>	—	—	0.8	V	—	Fig.3
Minimum setup time	t <sub>1</sub>	—	—	300	ns	V <sub>IH</sub> = 2.0V, V <sub>IL</sub> = 0.8V	—
Minimum shift pulse width	t <sub>2</sub>	—	—	1	μs	V <sub>IH</sub> = 2.0V, V <sub>IL</sub> = 0.8V	—
Minimum timing time	t <sub>3</sub>	—	—	1	μs	V <sub>IH</sub> = 2.0V, V <sub>IL</sub> = 0.8V	—
Maximum data transfer speed	f <sub>Max.</sub>	500	—	—	kHz	V <sub>IH</sub> = 2.0V, V <sub>IL</sub> = 0.8V	—

● Measurement circuits

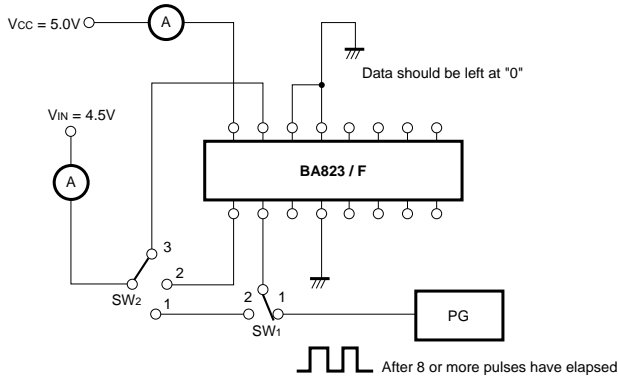

Fig. 2 I<sub>CC</sub> and I<sub>IH</sub> measurement circuit

Item	SW <sub>1</sub>	SW <sub>2</sub>
I <sub>CC</sub>	1	1
I <sub>IH</sub>	2	1 ~ 3

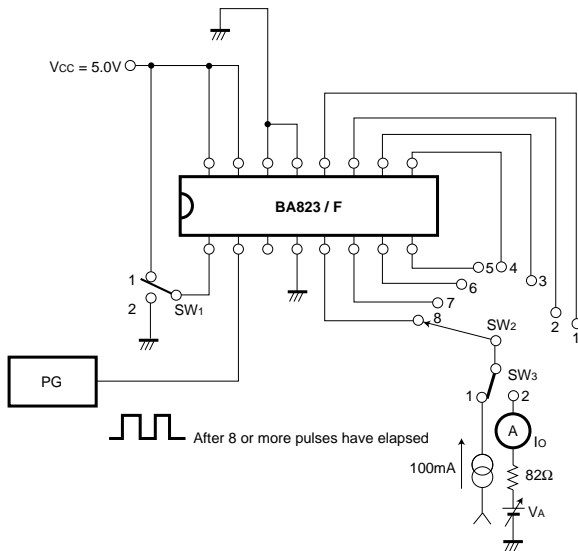

Fig. 3 V<sub>O ON</sub>, V<sub>O OFF</sub> and I<sub>OL</sub> measurement circuit

Item	SW <sub>1</sub>	SW <sub>2</sub>	SW <sub>3</sub>
V <sub>O ON</sub>	1	1 ~ 8	1
I <sub>OL</sub>	1	1 ~ 8	2
V <sub>O OFF</sub>	2	1 ~ 8	2

When tested at V<sub>O OFF</sub> : I<sub>O</sub> = 10μA  
 When tested at I<sub>O ON</sub> : V<sub>A</sub> = 30V

● Input conditions

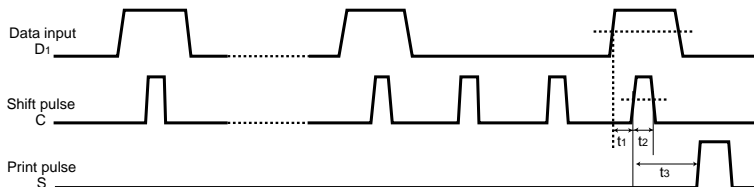
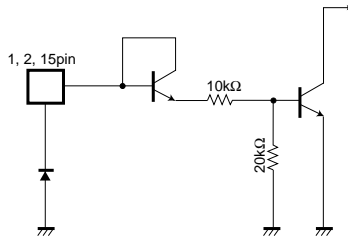

Fig. 4

● Input / output circuits

(a) Input circuit



(b) Output circuit

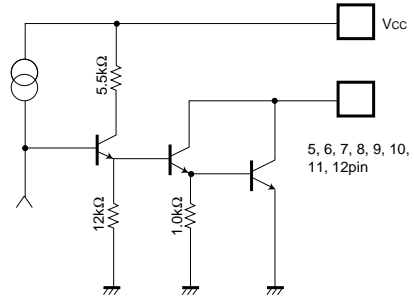

(c) Data output circuit

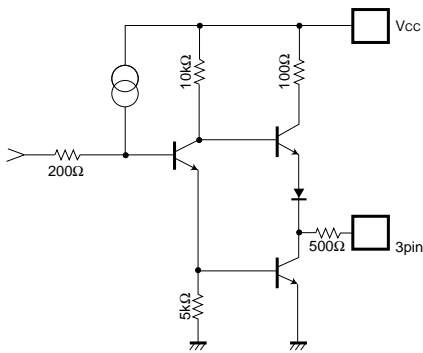

Fig.5

● Electrical characteristic curves

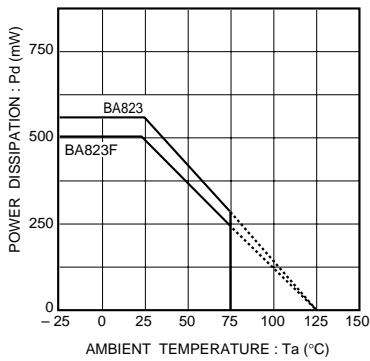

Fig. 6 Power dissipation vs. ambient temperature

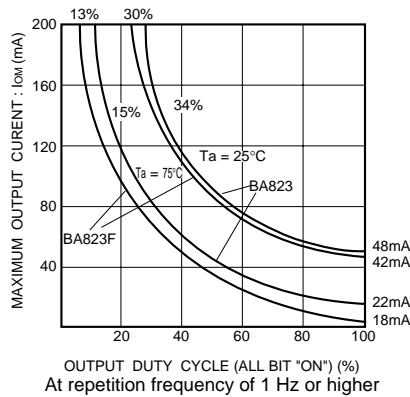

Fig. 7 Output conditions

## ●Pin descriptions

Pin No.	Pin name	Code	Function
2	SHIFT PULSE	C	Shift pulse of shift register
15	DATA INPUT	D <sub>1</sub>	Data input of shift pulse registered using shift pulse rise
1	STROBE	S	When "1", the content of the shift register is output
12	OUTPUT	$\bar{O}_0$	"0" when the content of the register is "1" on the 1st bit
11	OUTPUT	$\bar{O}_1$	"0" when the content of the register is "1" on the 2nd bit
10	OUTPUT	$\bar{O}_2$	"0" when the content of the register is "1" on the 3rd bit
9	OUTPUT	$\bar{O}_3$	"0" when the content of the register is "1" on the 4th bit
8	OUTPUT	$\bar{O}_4$	"0" when the content of the register is "1" on the 5th bit
7	OUTPUT	$\bar{O}_5$	"0" when the content of the register is "1" on the 6th bit
6	OUTPUT	$\bar{O}_6$	"0" when the content of the register is "1" on the 7th bit
5	OUTPUT	$\bar{O}_7$	"0" when the content of the register is "1" on the 8th bit
3	DATA OUTPUT	D <sub>0</sub>	Has passed the $\bar{O}_7$ output circuit and becomes the input for the next step
16	V <sub>CC</sub>	V <sub>CC</sub>	Normally 5.0V used ( $\pm 10\%$ )
13	GND	GND <sub>1</sub>	$\bar{O}_0$ to $\bar{O}_3$ output circuit GND
4	GND	GND <sub>2</sub>	$\bar{O}_4$ to $\bar{O}_7$ output circuit GND
14	GND	GND (Dig)	Logic circuit GND

●Timing chart

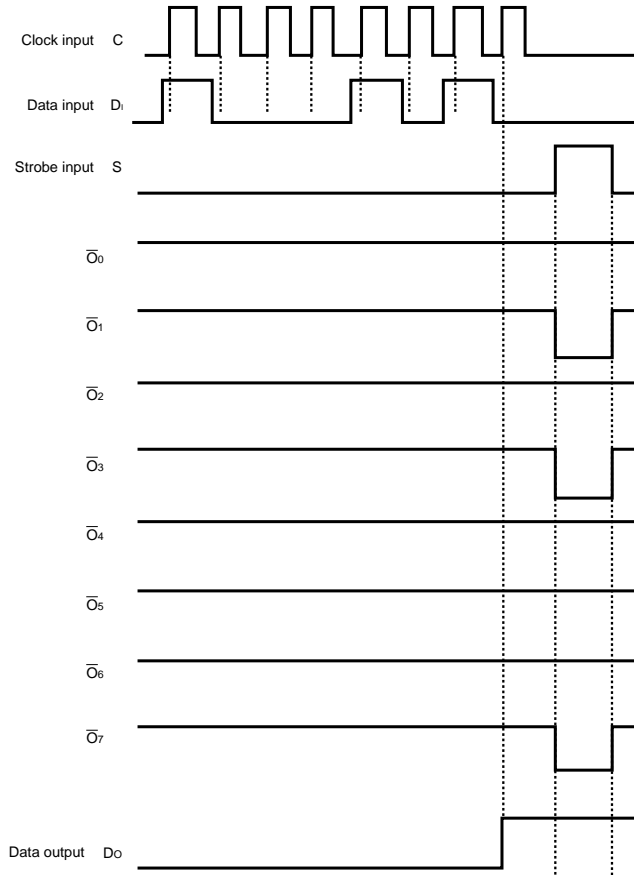

Fig.8

●Application example

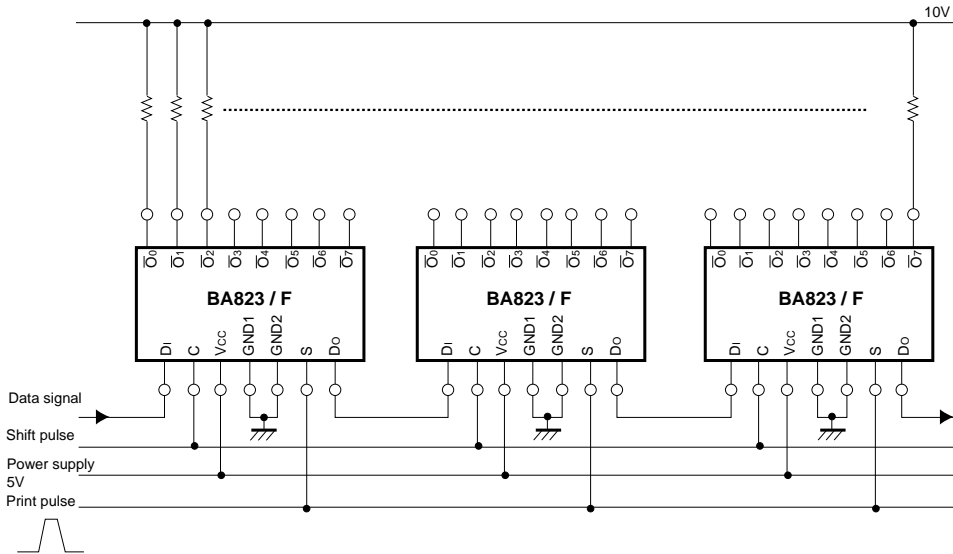

Fig.9

Example of printing using a strobe pulse  
 This offers the advantage that the common line (large

current) of the heat element does not need to be switched.

●Circuit operation

The BA823 has the internal configuration shown in the logic diagram, with the following three input pins: clock C, data DI, and strobe S. Data input is synchronized to the clock, with data being read serially at the rising edge. The content of the set shift register appears at output terminals  $\overline{O}_0$  to  $\overline{O}_7$ , as shown in the timing chart in Figure 8, depending on the strobe input, with that

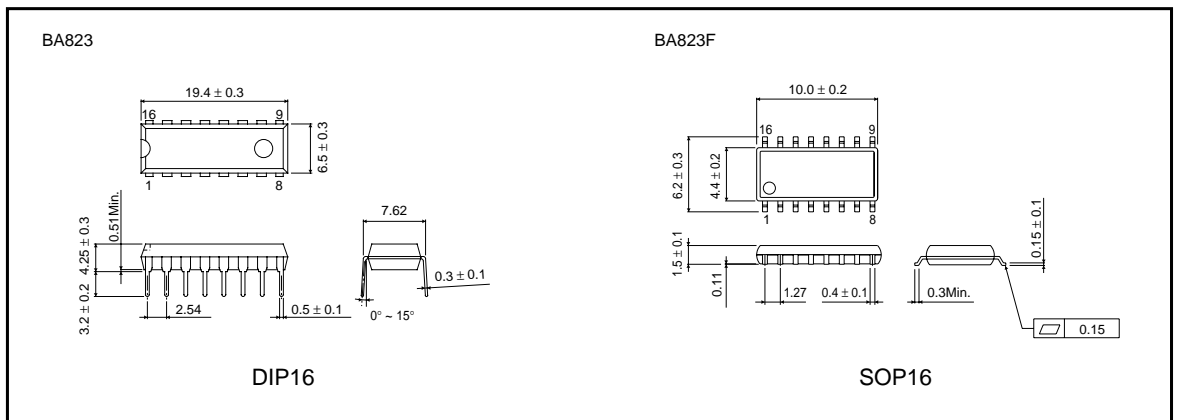

pulse width being the same as that of the strobe input. The data output pin  $\overline{D}_0$  is used when ICs are connected in cascade format, and when the output for the last stage of the shift register appears, is connected to the next data input pin  $\overline{D}_i$ . When these clock and strobe latches and power switch are used in common, the output pins can be increased by eight bits each.

●External dimensions (Units: mm)



## Looking for pricing, stock, or lifecycle information?

Click below to explore more details on WIN SOURCE:

-  [View BA823 on WIN SOURCE](#)
-  [Rohm Semiconductor Information](#)

## Optimize Your Supply Chain with WIN SOURCE Solutions

-  Global Sourcing Solution
-  Obsolete Management
-  Cost Control Management
-  Shortage Management
-  Alternative Solution
-  Excess Inventory Management