



**THE DATASHEET OF  
ZL30251LDF1**





# ZL30250, ZL30251

## 4-Input, 3-Output Any-to-Any Clock Multiplier and Frequency Synthesizer ICs

Data Sheet

January 2018

### Features

- **Four Input Clocks**
  - One crystal/CMOS input
  - Two differential/CMOS inputs
  - One single-ended/CMOS input
  - Any input frequency from 9.72MHz to 1250MHz (9.72MHz to 300MHz for CMOS)
  - Clock selection by pin or register control
- **Low-Jitter Fractional-N APLL and 3 Outputs**
  - Any output frequency from <1Hz to 1035MHz
  - High-resolution fractional frequency conversion with 0ppm error
  - Easy-to-configure, encapsulated design requires no external VCXO or loop filter components
  - Each output has independent dividers
  - Output jitter as low as 0.16ps RMS (12kHz-20MHz integration band)
  - Outputs are CML or 2xCMOS, can interface to LVDS, LVPECL, HSTL, SSTL and HCSL
  - In 2xCMOS mode, the P and N pins can be different frequencies (e.g. 125MHz and 25MHz)
  - Per-output supply pin with CMOS output voltages from 1.5V to 3.3V

### Ordering Information

ZL30250LDG1	32 Pin QFN	Trays
ZL30250LDF1	32 Pin QFN	Tape and Reel
ZL30251LDG1	32 Pin QFN	Trays
ZL30251LDF1	32 Pin QFN	Tape and Reel

Matte Tin

Package size: 5 x 5 mm

-40°C to +85°C

- Precise output alignment circuitry and per-output phase adjustment
- Per-output enable/disable and glitchless start/stop (stop high or low)
- **General Features**
  - Automatic self-configuration at power-up from external (ZL30250) or internal (ZL30251) EEPROM; up to four configs, pin-selectable
  - SPI or I<sup>2</sup>C processor Interface
  - Numerically controlled oscillator mode
  - Spread-spectrum modulation mode
  - Tiny 5x5mm QFN package
  - Easy-to-use evaluation software

### Applications

- Frequency conversion and frequency synthesis in a wide variety of equipment types

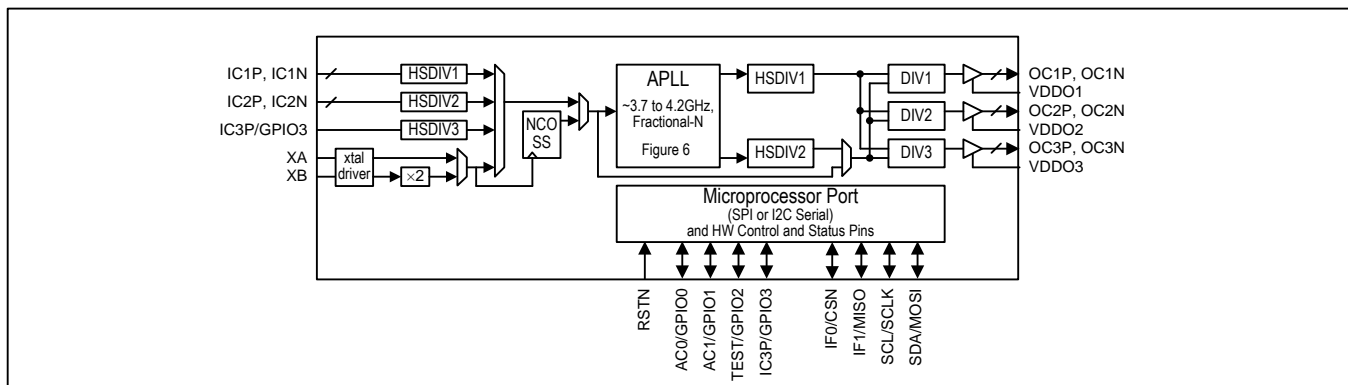

Figure 1 - Functional Block Diagram

## **Table of Contents**

<b>1. APPLICATION EXAMPLES .....</b>	<b>5</b>
<b>2. DETAILED FEATURES.....</b>	<b>5</b>
2.1 INPUT CLOCK FEATURES .....	5
2.2 APLL FEATURES.....	5
2.3 OUTPUT CLOCK FEATURES .....	5
2.4 GENERAL FEATURES .....	5
2.5 EVALUATION SOFTWARE.....	6
<b>3. PIN DIAGRAM.....</b>	<b>6</b>
<b>4. PIN DESCRIPTIONS .....</b>	<b>7</b>
<b>5. FUNCTIONAL DESCRIPTION .....</b>	<b>9</b>
5.1 DEVICE IDENTIFICATION .....	9
5.2 PIN-CONTROLLED AUTOMATIC CONFIGURATION AT RESET .....	9
5.2.1 ZL30250—External EEPROM or No EEPROM.....	10
5.2.2 ZL30251—Internal EEPROM.....	10
5.3 LOCAL OSCILLATOR OR CRYSTAL .....	10
5.3.1 External Oscillator .....	11
5.3.2 External Crystal and On-Chip Driver Circuit .....	11
5.3.3 Clock Doubler.....	12
5.3.4 Ring Oscillator (for System Start-Up).....	12
5.4 INPUT SIGNAL FORMAT CONFIGURATION.....	12
5.5 NUMERICALLY CONTROLLED OSCILLATOR / SPREAD SPECTRUM BLOCK (NCO/SS).....	13
5.5.1 Numerically Controlled Oscillator (NCO) Mode .....	13
5.5.2 Spread-Spectrum Modulation Mode .....	13
5.6 APLL CONFIGURATION .....	14
5.6.1 APLL Input Selection and Frequency .....	14
5.6.2 APLL Output Frequency.....	14
5.6.3 APLL Phase Adjustment.....	15
5.7 OUTPUT CLOCK CONFIGURATION .....	15
5.7.1 Output Enable, Signal Format, Voltage and Interfacing .....	16
5.7.2 Output Frequency Configuration.....	16
5.7.3 Output Duty Cycle Adjustment.....	17
5.7.4 Output Phase Adjustment and Phase Alignment.....	17
5.7.4.1 Phase Adjustment.....	17
5.7.4.2 Phase Alignment, Output-to-Output.....	18
5.7.4.3 Phase Alignment, Input-to-Output .....	19
5.7.5 Output Clock Start and Stop .....	19
5.7.6 A-to-B Phase Offset Measurement .....	20
5.8 MICROPROCESSOR INTERFACE .....	23
5.8.1 SPI Slave .....	23
5.8.2 SPI Master (ZL30250 Only) .....	25
5.8.3 I <sup>2</sup> C Slave .....	26
5.9 INTERRUPT LOGIC .....	28
5.10 RESET LOGIC.....	29
5.11 POWER-SUPPLY CONSIDERATIONS .....	29
5.12 AUTO-CONFIGURATION FROM EEPROM .....	29
5.12.1 Generating Device Configurations .....	29
5.12.2 Direct EEPROM Write Mode (ZL30251 Only) .....	30
5.12.3 Holding Other Devices in Reset During Auto-Configuration .....	30

---

5.13	POWER SUPPLY DECOUPLING AND LAYOUT RECOMMENDATIONS .....	30
<b>6.</b>	<b>REGISTER DESCRIPTIONS .....</b>	<b>30</b>
6.1	REGISTER TYPES .....	30
6.1.1	<i>Status Bits .....</i>	<i>30</i>
6.1.2	<i>Configuration Fields .....</i>	<i>30</i>
6.1.3	<i>Multiregister Fields .....</i>	<i>30</i>
6.1.4	<i>Bank-Switched Registers (ZL30251 Only) .....</i>	<i>31</i>
6.2	REGISTER MAP .....	31
6.3	REGISTER DEFINITIONS .....	33
6.3.1	<i>Global Configuration Registers .....</i>	<i>33</i>
6.3.2	<i>Status Registers .....</i>	<i>41</i>
6.3.3	<i>APLL Configuration Registers .....</i>	<i>49</i>
6.3.4	<i>Output Clock Configuration Registers .....</i>	<i>55</i>
6.3.5	<i>Input Clock Configuration Registers .....</i>	<i>61</i>
6.3.6	<i>NCO/Spread-Spectrum Configuration Registers .....</i>	<i>61</i>
<b>7.</b>	<b>ELECTRICAL CHARACTERISTICS .....</b>	<b>63</b>
<b>8.</b>	<b>PACKAGE AND THERMAL INFORMATION .....</b>	<b>74</b>
8.1	PACKAGE TOP MARK FORMAT .....	74
8.2	THERMAL SPECIFICATIONS .....	75
<b>9.</b>	<b>MECHANICAL DRAWING .....</b>	<b>76</b>
<b>10.</b>	<b>ACRONYMS AND ABBREVIATIONS .....</b>	<b>77</b>
<b>11.</b>	<b>DATA SHEET REVISION HISTORY .....</b>	<b>77</b>

### List of Figures

Figure 1 - Functional Block Diagram .....	1
Figure 2 - Ethernet Frequency Synthesis Application .....	5
Figure 3 - PCI Express Frequency Multiplication Application .....	5
Figure 4 - Pin Diagram .....	6
Figure 5 - Crystal Equivalent Circuit / Recommended Crystal Circuit .....	11
Figure 6 - APLL Block Diagram .....	14
Figure 7 - SPI Read Transaction Functional Timing .....	24
Figure 8 - SPI Write Enable Transaction Functional Timing (ZL30251 Only) .....	24
Figure 9 - SPI Write Transaction Functional Timing .....	25
Figure 10 – I <sup>2</sup> C Read Transaction Functional Timing .....	27
Figure 11 – I <sup>2</sup> C Register Write Transaction Functional Timing .....	27
Figure 12 – I <sup>2</sup> C EEPROM Write Transaction Functional Timing (ZL30251 Only) .....	27
Figure 13 – I <sup>2</sup> C EEPROM Read Status Transaction Functional Timing (ZL30251 Only) .....	27
Figure 14 – Interrupt Structure .....	28
Figure 15 - Electrical Characteristics: Clock Inputs .....	65
Figure 16 - Example External Components for Differential Input Signals .....	66
Figure 17 - Electrical Characteristics: CML Clock Outputs .....	67
Figure 18 – Example External Components for CML Output Signals .....	67
Figure 19 – Example External Components for HCSL Output Signals .....	68
Figure 20 - SPI Slave Interface Timing .....	70
Figure 21 - SPI Master Interface Timing .....	72
Figure 22 - I <sup>2</sup> C Slave Interface Timing .....	73
Figure 23 - Non-customized Device Top Mark .....	74
Figure 24 - Custom Factory Programmed Device Top Mark .....	74

### List of Tables

Table 1 - Pin Descriptions .....	7
Table 2 - Crystal Selection Parameters .....	12
Table 3 – SPI Commands .....	23
Table 4 - Register Map .....	31
Table 5 - Recommended DC Operating Conditions .....	63
Table 6 - Electrical Characteristics: Supply Currents .....	63
Table 7 - Electrical Characteristics: Non-clock CMOS Pins .....	64
Table 8 - Electrical Characteristics: XA Clock Input .....	64
Table 9 - Electrical Characteristics: Clock Inputs, ICxP/N .....	65
Table 10 - Electrical Characteristics: CML Clock Outputs .....	66
Table 11 - Electrical Characteristics: CMOS and HSTL (Class I) Clock Outputs .....	68
Table 12 - Electrical Characteristics: APLL Frequencies .....	68
Table 13 - Electrical Characteristics: Jitter Specifications .....	69
Table 14 - Electrical Characteristics: Typical Output Jitter Performance .....	69
Table 15 - Electrical Characteristics: Typical Input-to-Output Clock Delay .....	69
Table 16 - Electrical Characteristics: Typical Output-to-Output Clock Delay .....	69
Table 17 - Electrical Characteristics: SPI Slave Interface Timing, Device Registers .....	70
Table 18 - Electrical Characteristics: SPI Slave Interface Timing, Internal EEPROM (ZL30251 Only) .....	71
Table 19 - Electrical Characteristics: SPI Master Interface Timing (ZL30250 Only) .....	72
Table 20 - Electrical Characteristics: I <sup>2</sup> C Slave Interface Timing .....	73
Table 21 – Package Top Mark Legend .....	74
Table 22 - 5x5mm QFN Package Thermal Properties .....	75

## 1. Application Examples

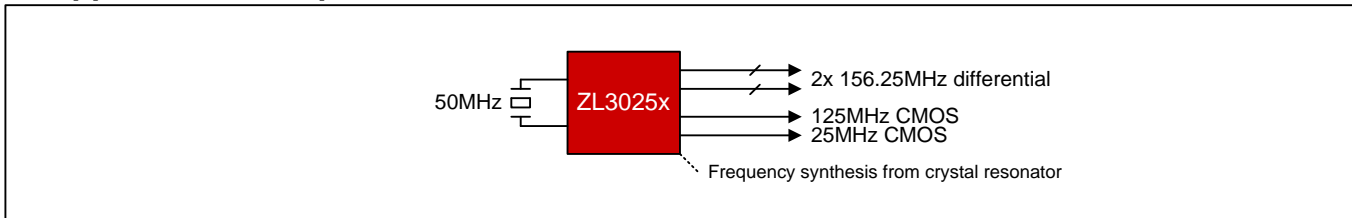

Figure 2 - Ethernet Frequency Synthesis Application

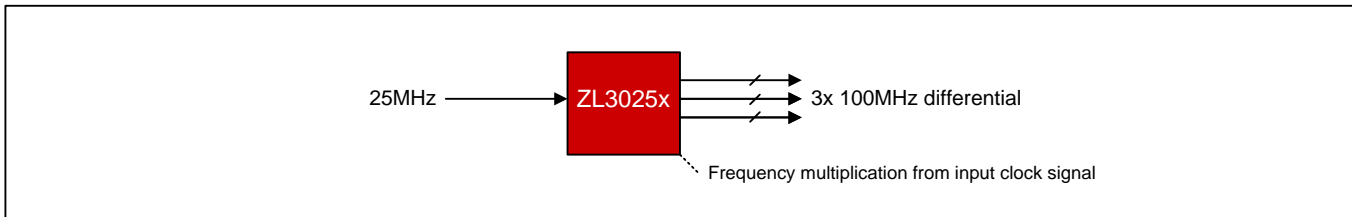

Figure 3 - PCI Express Frequency Multiplication Application

## 2. Detailed Features

### 2.1 Input Clock Features

- Four input clocks: one crystal/CMOS, two differential/CMOS, one single-ended/CMOS
- Input clocks can be any frequency from 9.72MHz up to 1250MHz (differential) or 300MHz (CMOS)

### 2.2 APLL Features

- Very high-resolution fractional (i.e. non-integer) multiplication
- Any-to-any frequency conversion with 0ppm error
- Two high-speed dividers (integers 4 to 15, half divides 4.5 to 7.5)
- Easy-to-configure, completely encapsulated design requires no external VCXO or loop filter components
- Bypass mode supports system testing

### 2.3 Output Clock Features

- Three low-jitter output clocks
- Each output can be one differential output or two CMOS outputs
- Output clocks can be any frequency from 1Hz to 1035MHz (250MHz max for CMOS and HSTL outputs)
- Output jitter as low as 0.16ps RMS (12kHz to 20MHz integration band)
- In CMOS mode, an additional divider allows the OCxN pin to be an integer divisor of the OCxP pin (example: OC3P 125MHz, OC3N 25MHz)
- Outputs easily interface with CML, LVDS, LVPECL, HSTL, SSTL, HCSL and CMOS components
- Supported telecom frequencies include PDH, SDH, Synchronous Ethernet, OTN
- Can produce clock frequencies for microprocessors, ASICs, FPGAs and other components
- Can produce PCIe clocks (PCIe gen. 1, 2 and 3)
- Sophisticated output-to-output phase alignment
- Per-output phase adjustment with high resolution and unlimited range
- Per-output enable/disable
- Per-output glitchless start/stop (stop high or low)

### 2.4 General Features

- SPI or I<sup>2</sup>C serial microprocessor interface
- Automatic self-configuration at power-up from external (ZL30250) or internal (ZL30251) EEPROM memory; pin control to specify one of four stored configurations

- Numerically controlled oscillator (NCO) mode allows system software to steer frequency with resolution better than 0.01ppb
- Spread-spectrum modulation mode (meets PCI Express requirements)
- Four general-purpose I/O pins each with many possible status and control options
- Reference can be fundamental-mode crystal, low-cost XO or clock signal from elsewhere in the system

**2.5 Evaluation Software**

- Simple, intuitive Windows-based graphical user interface
- Supports all device features and register fields
- Makes lab evaluation of the ZL30250 or ZL30251 quick and easy
- Generates configuration scripts to be stored in external (ZL30250) or internal (ZL30251) EEPROM
- Generates full or partial configuration scripts to be run on a system processor
- Works with or without a ZL30250 or ZL30251 evaluation board

**3. Pin Diagram**

The device is packaged in a 5x5mm 32-pin QFN.

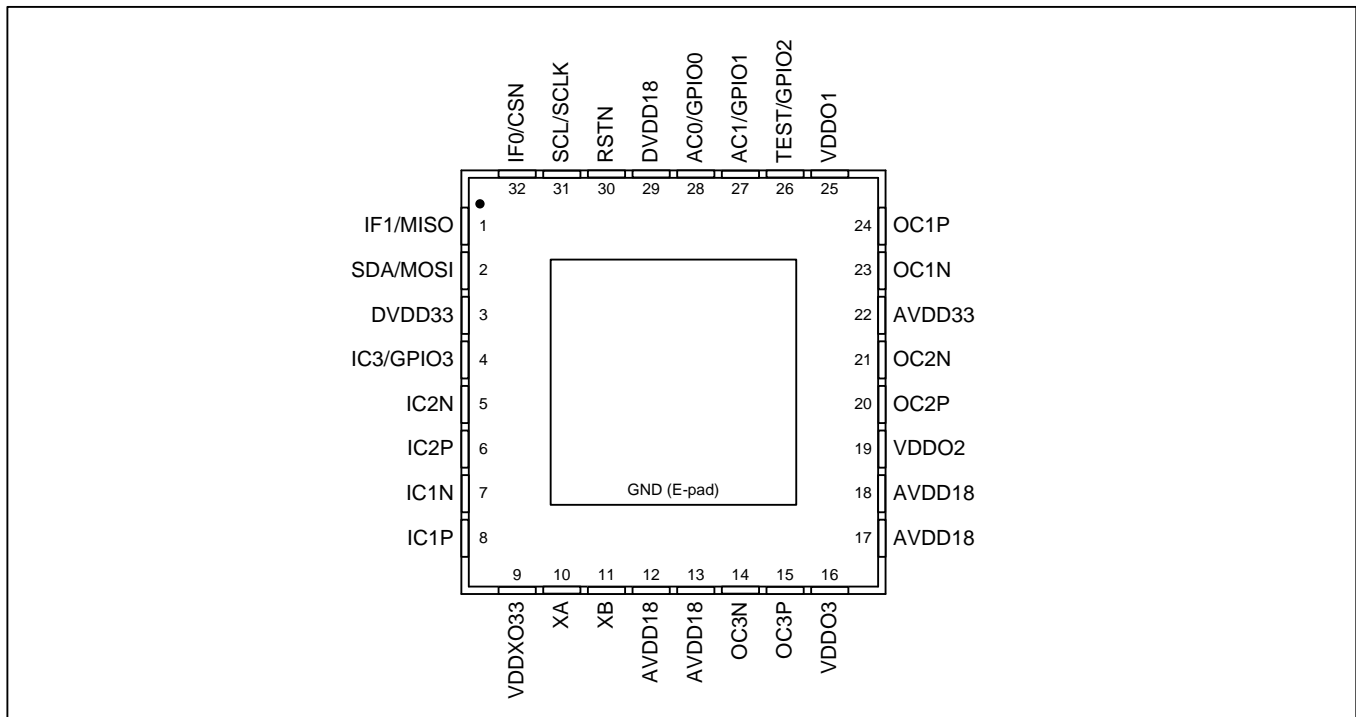

**Figure 4 - Pin Diagram**

## 4. Pin Descriptions

All device inputs and outputs are LVCMOS unless described otherwise. The Type column uses the following symbols: I – input, I<sub>PU</sub> – input with 50kΩ internal pullup resistor, O – output, A – analog, P – power supply pin. All GPIO and SPI/I<sup>2</sup>C interface pins have Schmitt-trigger inputs and have output drivers that can be disabled (high impedance).

**Table 1 - Pin Descriptions**

Pin #	Name	Type	Description
8 7 6 5 4	IC1P IC1N IC2P IC2N IC3P/GPIO3	I I I I I/O	<p><b>Input Clock Pins</b> Differential or Single-ended signal format. Programmable frequency.</p> <p><i>Differential:</i> See <a href="#">Table 9</a> for electrical specifications, and see <a href="#">Figure 16</a> for recommended external circuitry for interfacing these differential inputs to LVDS, LVPECL, CML or HSCL output pins on neighboring devices.</p> <p><i>Single-ended:</i> For input signal amplitude &gt;2.5V, connect the signal directly to ICxP pin. For input signal amplitude ≤2.5V, AC-coupling the signal to ICxP is recommended. Connect the N pin to a capacitor (0.1μF or 0.01μF) to VSS. As shown in <a href="#">Figure 16</a>, the ICxP and ICxN pins are internally biased to approximately 1.3V. Treat the ICxN pin as a sensitive node; minimize stubs; do not connect to anything else including other ICxN pins.</p> <p><i>Unused:</i> Set ICEN.ICxEN=0. The ICxP and ICxN pins can be left floating.</p> <p>Note that the IC3N pin is not bonded out. A differential signal can be connected to IC3P by AC-coupling the POS trace to IC3P and terminating the signal on the driver side of the coupling cap. If not needed as an input clock pin, IC3P can behave as general-purpose I/O pin GPIO3, which is configured by <a href="#">GPIOCR2</a>. Its state is indicated in <a href="#">GPIOSR</a>.</p>
10 11	XA XB	A / I	<p><b>Crystal or Input Clock Pins</b> <i>Crystal:</i> <a href="#">MCR1.XAB=01</a>. An on-chip crystal driver circuit is designed to work with an external crystal connected to the XA and XB pins. See section <a href="#">5.3.2</a> for crystal characteristics and recommended external components.</p> <p><i>Input Clock:</i> <a href="#">MCR1.XAB=10</a>. An external local oscillator or clock signal can be connected to the XA pin. The XB pin must be left unconnected.</p>
24 23 20 21 15 14	OC1P OC1N OC2P OC2N OC3P OC3N	O	<p><b>Output Clock Pins</b> CML, HSTL or 1 or 2 CMOS. Programmable frequency and drive strength. See <a href="#">Table 10</a> and <a href="#">Figure 18</a> for electrical specifications and recommended external circuitry for interfacing to LVDS, LVPECL or CML input pins on neighboring devices.</p> <p>See <a href="#">Table 11</a> for electrical specifications for interfacing to CMOS and HSTL inputs on neighboring devices.</p> <p>See <a href="#">Figure 19</a> for recommended external circuitry for interfacing to HCSL inputs on neighboring devices.</p>
30	RSTN	I <sub>PU</sub>	<p><b>Reset (Active Low)</b> When this global asynchronous reset is pulled low, all internal circuitry is reset to default values. The device is held in reset as long as RSTN is low. See section <a href="#">5.10</a>.</p>

**Table 1 - Pin Descriptions (continued)**

Pin #	Name	Type	Description
28 27	AC0/GPIO0 AC1/GPIO1	I/O	<p><b>Auto-Configure [1:0] / General Purpose I/O 0 and 1</b></p> <p><i>Auto Configure:</i> On the rising edge of RSTN these pins behave as AC[1:0] and specify one of the configurations stored in EEPROM. See section 5.2.</p> <p><i>General-Purpose I/O:</i> After reset these pins are GPIO0 and GPIO1. GPIOCR1 configures the pins. Their states are indicated in GPIOSR.</p>
26	TEST/GPIO2	I/O	<p><b>Factory Test / General Purpose I/O 2</b></p> <p><i>Factory Test:</i> On the rising edge of RSTN the pin behaves as TEST. Factory test mode is enabled when TEST is high. For normal operation TEST must be low on the rising edge of RSTN.</p> <p><i>General-Purpose I/O:</i> After reset this pin is GPIO2. GPIOCR2 configures the pin. Its state is indicated in GPIOSR.</p>
32	IF0/CSN	I/O	<p><b>Interface Mode 0 / SPI Chip Select (Active Low)</b></p> <p><i>Interface Mode:</i> On the rising edge of RSTN the pin behaves as IF0 and, together with IF1, specifies the interface mode for the device. See section 5.2.</p> <p><i>SPI Chip Select:</i> After reset this pin is CSN. When the device is configured as a SPI slave, an external SPI master must assert (low) CSN to access device registers. When the device is configured as a SPI master (ZL30250 only), the device asserts CSN to access an external SPI EEPROM during auto-configuration.</p>
31	SCL/SCLK	I/O	<p><b>I<sup>2</sup>C Clock / SPI Clock</b></p> <p><i>I<sup>2</sup>C Clock:</i> When the device is configured as an I<sup>2</sup>C slave, an external I<sup>2</sup>C master must provide the I<sup>2</sup>C clock signal on the SCL pin. Note that I<sup>2</sup>C requires an external pullup resistor on this signal. See the I<sup>2</sup>C specification for details.</p> <p><i>SPI Clock:</i> When the device is configured as a SPI slave, an external SPI master must provide the SPI clock signal on SCLK. When the device is configured as a SPI master (ZL30250 only), the device drives SCLK as an output to clock accesses to an external SPI EEPROM during auto-configuration.</p>
1	IF1/MISO	I/O	<p><b>Interface Mode 1 / SPI Master-In-Slave-Out</b></p> <p><i>Interface Mode:</i> On the rising edge of RSTN the pin behaves as IF1 and, together with IF0, specifies the interface mode for the device. See section 5.2.</p> <p><i>SPI MISO:</i> After reset this pin is MISO. When the device is configured as a SPI slave, the device outputs data to an external SPI master on MISO during SPI read transactions. When the device is configured as a SPI master (ZL30250 only), the device receives data on MISO from an external SPI EEPROM during auto-configuration.</p> <p>Note: On rev A parts, in I<sup>2</sup>C interface mode this pin toggles between driving low and high-impedance during register accesses. Therefore in I<sup>2</sup>C mode this pin must not be wired directly to VDD. To implement a static high value on IF1/MISO, wire it to VDD through a resistor (approximately 10kΩ recommended).</p>
2	SDA/MOSI	I/O	<p><b>I<sup>2</sup>C Data / SPI Master-Out-Slave-In</b></p> <p><i>I<sup>2</sup>C Data:</i> When the device is configured as an I<sup>2</sup>C slave, SDA is the bidirectional data line between the device and an external I<sup>2</sup>C master. Note that I<sup>2</sup>C requires an external pullup resistor on this signal. See the I<sup>2</sup>C</p>

Pin #	Name	Type	Description
			specification for details.  <i>SPI MOSI:</i> When the device is configured as a SPI slave, an external SPI master sends commands, addresses and data to the device on MOSI. When the device is configured as a SPI master (ZL30250 only), the device sends commands, addresses and data on MOSI to an external SPI EEPROM during auto-configuration.

**Table 1 - Pin Descriptions (continued)**

Pin #	Name	Type	Description
12 13 17 18	AVDD18	P	<b>Analog Power Supply.</b> 1.8V $\pm$ 5%.
22	AVDD33	P	<b>Analog Power Supply.</b> 3.3V $\pm$ 5%.
29	DVDD18	P	<b>Digital Power Supply.</b> 1.8V $\pm$ 5%.
3	DVDD33	P	<b>Digital Power Supply.</b> 3.3V $\pm$ 5%.
25	VDDO1	P	<b>Output OC1 Power Supply.</b> 1.5V to 3.3V $\pm$ 5%.
19	VDDO2	P	<b>Output OC2 Power Supply.</b> 1.5V to 3.3V $\pm$ 5%.
16	VDDO3	P	<b>Output OC3 Power Supply.</b> 1.5V to 3.3V $\pm$ 5%.
9	VDDXO33	P	<b>Analog Power Supply for Crystal Driver Circuitry.</b> 3.3V $\pm$ 5%.
E-pad	VSS	P	<b>Ground.</b> 0 Volts.

## 5. Functional Description

### 5.1 Device Identification

The 12-bit read-only ID field and the 4-bit revision field are found in the [ID1](#) and [ID2](#) registers. Contact the factory to interpret the revision value and determine the latest revision.

### 5.2 Pin-Controlled Automatic Configuration at Reset

The device configuration is determined at reset (i.e. on the rising edge of RSTN) by the signal levels on five device pins: TEST/GPIO2, AC1/GPIO1, AC0/GPIO0, IF1/MISO and IF0/CSN. For each of these pins, the first name (TEST, AC1, AC0, IF1, IF0) indicates their function when they are sampled by the rising edge of the RSTN pin. The second name refers to their function after reset. The values of these pins are latched into the [CFGSR](#) register when RSTN goes high. To ensure the device properly samples the reset values of these pins, the following guidelines should be followed:

1. Any pullup or pulldown resistors used to set the value of these pins at reset should be 1k $\Omega$ .
2. RSTN must be asserted at least as long as specified in section [5.10](#).

The hardware configuration pins are grouped into three sets:

1. TEST - Manufacturing test mode
2. IF[1:0] – Microprocessor interface mode and I<sup>2</sup>C address
3. AC[1:0] – Auto-configuration from EEPROM

The TEST pin selects manufacturing test modes when TEST=1 (the AC[1:0] pins specify the test mode). For ZL30251, TEST=1 and AC[1:0]=00 configures the part so that production SPI EEPROM programmers can program the internal EEPROM (see section [5.12.2](#)). For more information about auto-configuration from EEPROM see section [5.12.1](#).

### 5.2.1 ZL30250—External EEPROM or No EEPROM

For the ZL30250 the IF[1:0] pins specify the processor interface mode and the I<sup>2</sup>C slave address. When IF[1:0]=11 (SPI) two options are available:

If AC[1:0]=00 the device sets up its processor interface as SPI slave through which it can be configured by software running on the SPI master. In this option the device cannot auto-configure from an external EEPROM.

If AC[1:0]=01, 10, or 11 the device first sets up its processor interface as a SPI master. It then auto-configures itself by reading the configuration number specified by AC[1:0] from an external SPI EEPROM connected to its SPI pins. After auto-configuration is complete, the device reconfigures its processor interface to be SPI slave.

These options are summarized in the following table:

IF1	IF0	AC1	AC0	Processor Interface	External EEPROM	Auto Configuration
0	0	0	0	I <sup>2</sup> C, slave address 11011 00	No	n/a
0	1	0	0	I <sup>2</sup> C, slave address 11011 01	No	n/a
1	0	0	0	I <sup>2</sup> C, slave address 11011 10	No	n/a
1	1	0	0	SPI Slave	No	n/a
1	1	0	1	SPI Master to external EEPROM for auto-configuration then SPI Slave	Yes	Configuration 1
1	1	1	0		Yes	Configuration 2
1	1	1	1		Yes	Configuration 3

Notes about the device auto-configuring from external EEPROM:

1. The device's CSN pin must have a pull-up resistor to VDD to ensure its processor interface is inactive after auto-configuration is complete. The SCLK, MISO and MOSI pins should also have pull-up resistors to VDD to keep them from floating.
2. If a processor or similar device will access device registers after the device has auto-configured from external EEPROM, the SPI SCLK, MOSI and MISO wires can be connected directly to the processor, the device and the external EEPROM. The processor and device CSN pins can be wired together also. The EEPROM CSN signal must be controlled by the device's CSN pin during device auto-configuration and then held inactive when the processor accesses device registers.

### 5.2.2 ZL30251—Internal EEPROM

For the ZL30251 the IF[1:0] pins specify the processor interface mode and the I<sup>2</sup>C slave address. The AC[1:0] pins specify which of four device configurations in the EEPROM to execute after reset.

IF1	IF0	Processor Interface
0	0	I <sup>2</sup> C, slave address 11011 00
0	1	I <sup>2</sup> C, slave address 11011 01
1	0	I <sup>2</sup> C, slave address 11011 10
1	1	SPI Slave

AC1	AC0	Auto Configuration
0	0	Configuration 0
0	1	Configuration 1
1	0	Configuration 2
1	1	Configuration 3

## 5.3 Local Oscillator or Crystal

Section 5.3.1 describes how to connect an external oscillator and the required characteristics of the oscillator. Section 5.3.2 describes how to connect an external crystal to the on-chip crystal driver circuit and the required characteristics of the crystal.

### 5.3.1 External Oscillator

A signal from an external oscillator can be connected to the XA pin (XB must be left unconnected). [Table 8](#) specifies the range of possible frequencies for the XA input. To minimize jitter, the signal must be properly terminated and must have very short trace length. A poorly terminated single-ended signal can greatly increase output jitter, and long single-ended trace lengths are more susceptible to noise. When `MCR1.XAB=10`, XA is enabled as a single-ended input.

While the stability of the external oscillator can be important, its absolute frequency accuracy is less important because any known frequency inaccuracy of the oscillator can be compensated. When the device is configured for NCO or spread-spectrum operation, the `DFREQZ` parameter can be used to compensate for oscillator frequency error. When the device is configured for APLL-only mode, the APLL's fractional feedback divider value (`AFBDIV`) can be adjusted by ppb or ppm to compensate for oscillator frequency error.

The jitter on output clock signals depends on the phase noise and frequency of the external oscillator. For the device to operate with the lowest possible output jitter, the external oscillator should have the following characteristics:

- Phase Jitter: less than 0.1ps RMS over the 12kHz to 5MHz integration band
- Frequency: The higher the better, all else being equal

### 5.3.2 External Crystal and On-Chip Driver Circuit

The on-chip crystal driver circuit is designed to work with a fundamental mode, AT-cut crystal resonator. See [Table 2](#) for recommended crystal specifications. To enable the crystal driver, set `MCR1.XAB=01`.

See [Figure 5](#) for the crystal equivalent circuit and the recommended external capacitor connections. To achieve a crystal load ( $C_L$ ) of 10pF, an external 16pF is placed in parallel with the 4pF internal capacitance of the XA pin, and an external 16pF is placed in parallel with the 4pF internal capacitance of the XB pin. The crystal then sees a load of 20pF in series with 20pF, which is 10pF total load. Note that the 16pF capacitance values in [Figure 5](#) include all capacitance on those nodes. If, for example, PCB trace capacitance between crystal pin and IC pin is 2pF then 14pF capacitors should be used to make 16pF total.

The crystal, traces, and two external capacitors should be placed on the board as close as possible to the XA and XB pins to reduce crosstalk of active signals into the oscillator. Also no active signals should be routed under the crystal circuitry.

Note: Crystals have temperature sensitivities that can cause frequency changes in response to ambient temperature changes. In applications where significant temperature changes are expected near the crystal, it is recommended that the crystal be covered with a thermal cap, or an external XO or TCXO should be used instead.

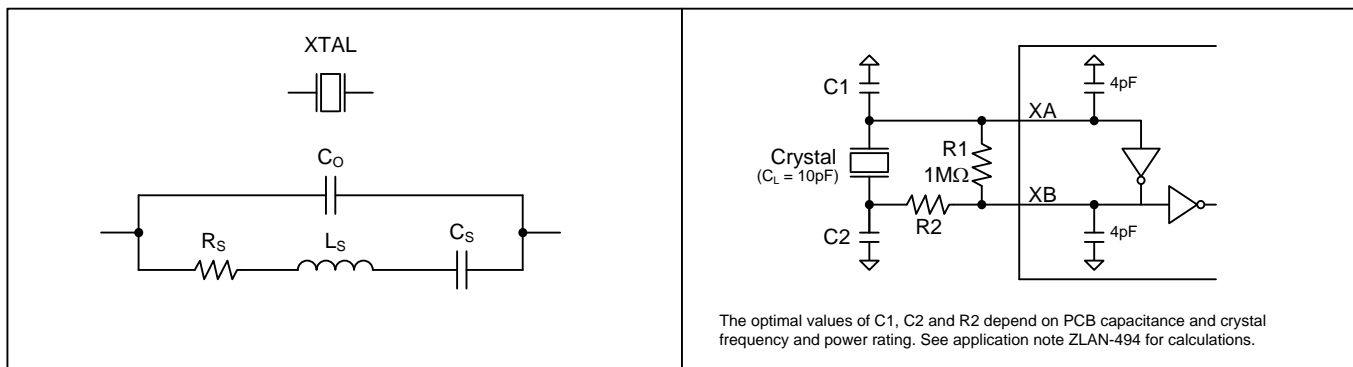

Figure 5 - Crystal Equivalent Circuit / Recommended Crystal Circuit

**Table 2 - Crystal Selection Parameters**

Parameter	Symbol	Min.	Typ.	Max.	Units
Crystal oscillation frequency <sup>1</sup>	f <sub>osc</sub>	25		60	MHz
Shunt capacitance	C <sub>O</sub>		2	5	pF
Load capacitance	C <sub>L</sub>		10		pF
Equivalent series resistance (ESR) <sup>2</sup>	f <sub>osc</sub> < 40MHz	R <sub>S</sub>		60	Ω
	f <sub>osc</sub> > 40MHz	R <sub>S</sub>		50	Ω
Maximum crystal drive level		100			μW

Note 1: Higher frequencies give lower output jitter, all else being equal.

Note 2: These ESR limits are chosen to constrain crystal drive level to less than 100μW. If the crystal can tolerate a drive level greater than 100μW then proportionally higher ESR is acceptable.

Parameter	Symbol	Min.	Typ.	Max.	Units
Crystal Frequency Stability vs. Power Supply	f <sub>FVD</sub>		0.2	0.5	ppm per 10% Δ in VDD

Any known frequency inaccuracy of the crystal can be compensated in the APLL by adjusting the APLL's fractional feedback divider value (AFBDIV) by ppb or ppm to compensate for crystal frequency error.

### 5.3.3 Clock Doubler

Figure 1 shows an optional clock doubler (“x2” block) following the crystal driver block. The doubler, which is enabled by setting MCR1.DBL=1, can be used to double the frequency of the internal crystal driver circuit or a clock signal on the XA pin. The following table shows scenarios when the clock doubler can be used.

Device Mode	With Crystal	With XO or Clock Signal
APLL, Integer Multiply	Maybe <sup>1</sup>	Maybe <sup>1</sup>
APLL, Fractional Multiply	Yes	Yes
NCO	Yes	Yes
Spread-Spectrum	Yes	Yes

Note 1: For APLL integer multiplication, use of the doubler is application-dependent. On the positive side, use of the doubler reduces random jitter. On the negative side, the doubler causes a large spur at the XA frequency (but this spur may be outside the band of interest for the application).

### 5.3.4 Ring Oscillator (for System Start-Up)

To ensure that registers can be written immediately after system start-up, in its power-on reset state the device operates its registers and processor interface from an internal ring oscillator.

When operating the device in NCO mode or spread spectrum mode, as soon as the external oscillator connected to the XA pin has stabilized and is ready to use, the MCR1.MCSEL bit must be set to source the NCO/SS master clock from XA. If the ring oscillator causes undesirable spurs it can be disabled (powered down) by setting MCR1.ROSCD=1.

When operating the part in APLL-only mode, a master clock signal on the XA pin is not required, and the ring oscillator is left enabled to provide a clock for the processor interface logic and registers.

## 5.4 Input Signal Format Configuration

Input clocks IC1, IC2 and IC3 are enabled by setting the enable bits in the ICEN register. The power consumed by a differential receiver is shown in Table 6. The electrical specifications for these inputs are listed in Table 9. Each input clock can be configured to accept nearly any differential signal format by using the proper set of external components (see Figure 16). To configure these differential inputs to accept single-ended CMOS signals, connect the single-ended signal to the ICxP pin, and connect the ICxN pin to a capacitor (0.1μF or 0.01μF) to VSS. Each ICxP and ICxN pin is internally biased to approximately 1.3V. If an input is not used, both ICxP and ICxN pins can be left floating. Note that the IC3N pin is not present. A differential signal can be connected to IC3P by AC-coupling

the POS trace to IC3P and terminating the signal on the driver side of the coupling cap. If not needed as an input clock pin, IC3P can behave as general-purpose I/O pin GPIO3.

## 5.5 Numerically Controlled Oscillator / Spread Spectrum Block (NCO/SS)

The NCO/SS block allows the device to behave as a numerically controlled oscillator and optionally perform spread-spectrum frequency modulation. This block is enabled by setting `PLLEN.NCSSEN=1` and is the input reference for the APLL when `APLLCR3.APLLMUX=11x`. The NCO/SS block requires a clock signal from an external oscillator connected to the XA pin (see section 5.3.1). Table 8 shows the allowable frequency range for the XA signal. Note that device output jitter increases as XA frequency decreases.

### 5.5.1 Numerically Controlled Oscillator (NCO) Mode

The NCO/SS block operates in NCO mode when `NCSSCR1.MODE=0001`. In this mode system software controls the NCO/SS block by controlling the value of the 40-bit `FREQZ` field in the `DFREQZ` registers. The resolution of frequency control is better than 0.01ppb.

The nominal `FREQZ` value, hereafter referred to as `FREQZ0`, is computed by the evaluation software for the desired device configuration. When the `FREQZ` field is set to the `FREQZ0` value, the device's output clock frequencies have a fractional frequency offset of zero with respect to the NCO master clock signal applied to the XA pin.

(Fractional frequency offset (FFO) is defined as  $(\text{actual\_frequency} - \text{nominal\_frequency}) / \text{nominal\_frequency}$ . FFO is a unitless number but is typically expressed in parts per billion (ppb), parts per million (ppm) or percent.)

To control the NCO, system software first reads the `FREQZ0` value from the device. `FREQZ0` is a 40-bit unsigned integer.

To change the NCO frequency to a specific FFO (in ppm), system software calculates `newFREQZ` (a 40-bit unsigned integer) as follows:

$$\text{newFREQZ} = \text{round}(\text{FREQZ0} * (1 + \text{FFO}/1\text{e}6))$$

System software then writes the `newFREQZ` value directly to the `FREQZ` field in the `DFREQZ` registers.

Note that any subsequent frequency changes are calculated using the same equation from the original `FREQZ0` value and are not a function of the previous `newFREQZ` value. The value of `newFREQZ` should be kept within  $\pm 1000\text{ppm}$  of `FREQZ0` and within  $\pm 500\text{ppm}$  of the previous `newFREQZ` value to avoid causing the APLL to lose lock. If spread spectrum modulation is also in use, the total frequency change caused by spread spectrum modulation and NCO control should be kept within  $\pm 5000\text{ppm}$  of `FREQZ0` to avoid causing the APLL to lose lock.

### 5.5.2 Spread-Spectrum Modulation Mode

For EMI-sensitive applications such as PCI Express, the device can perform spread spectrum modulation (SSM). In SSM the frequency of the output clock is continually varied over a narrow frequency range to spread the energy of the signal and thereby reduce EMI. This mode is a special case of NCO mode.

The NCO/SS block operates in spread spectrum mode when `NCSSCR1.MODE=0010`. In this mode the NCO/SS block performs frequency modulation starting from a base frequency offset specified in the 40-bit `FREQZ` field in the `DFREQZ` registers. The frequency modulation is triangle-wave center-spread of up to  $\pm 0.5\%$  deviation from the center frequency with modulation rate configurable from 25kHz to 55kHz. The nominal value of `FREQZ` and the spread configuration register values are determined by the evaluation software.

Down-spread applications can be supported by converting them into center-spread. This is done by setting the NCO/SS block's center frequency to be the center of the modulation range rather than the high end of range. For example, 100MHz with -1% downspread can be converted into  $\pm 0.5\%$  center spread with center frequency of  $100\text{MHz}/1.005=99.502488\text{MHz}$ .

In PCI Express applications the device can be used as a “point of load” spread-spectrum generator. In such an application, the 100MHz PCI Express clock signal without SSM can be generated centrally and distributed to various points in the system. A device positioned at one of those points can accept the 100MHz signal on its XA pin and generate multiple 100MHz signals on its outputs. System software can then choose to enable or disable SSM in the device as needed to suit the needs of the application.

## 5.6 APLL Configuration

### 5.6.1 APLL Input Selection and Frequency

The APLL can lock to any of inputs IC1 through IC3, a clock signal on XA (optionally clock-doubled), or the crystal driver circuit (optionally clock-doubled) when a crystal is connected to XA and XB. The APLL can also lock to the output of the NCO/SS block (see section 5.5).

The input to the APLL can be controlled by a GPIO pin or by the [APLLCR3.APLLMUX](#) register field. When [APLLCR3.EXTSW=0](#), the [APLLCR3.APLLMUX](#) register field controls the APLL input mux.

When [APLLCR3.EXTSW=1](#), a GPIO pin controls the APLL input mux. When the GPIO pin is low, the mux selects the input specified by [APLLCR3.APLLMUX](#). When the GPIO pin is high, the mux selects the input specified by [APLLCR3.ALTMUX](#). [MCR2.EXTSS](#) specifies which GPIO pin controls this behavior.

In APLL-only mode, the frequencies of all enabled input clocks (ICx and XA) must divide to a common APLL phase-frequency detector (PFD) frequency from 9.72MHz to 156.25MHz. In this mode the input high-speed dividers ([ICxCR1.HSDIV](#)) can be used to divide the ICx frequencies by 1, 2, 4 or 8. The XA pin does not have an internal divider, and, therefore, if XA is an enabled input clock then the XA frequency sets the APLL common PFD frequency. The polarity of an ICx input signal can be inverted by setting [ICxCR1.POL](#).

### 5.6.2 APLL Output Frequency

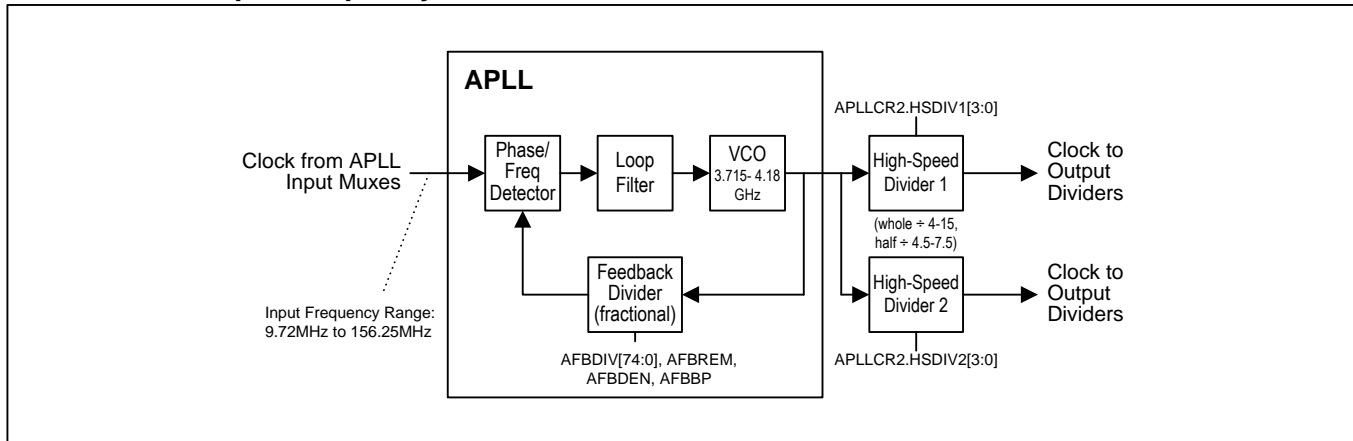

Figure 6 - APLL Block Diagram

The APLL is enabled when [PLEN.APLEN=1](#). The APLL has a fractional-N architecture and therefore can produce output frequencies that are either integer or non-integer multiples of the input clock frequency. [Figure 6](#) shows a block diagram of the APLL, which is built around an ultra-low-jitter multi-GHz VCO. Register fields [AFBDIV](#), [AFBREM](#), [AFBDEN](#) and [AFBBP](#) configure the frequency multiplication ratio of the APLL. The [APLLCR2.HSDIV1](#) and [HSDIV2](#) fields specify how the VCO frequency is divided down by the high-speed dividers. Dividing by six is the typical setting to produce 622.08MHz for SDH/SONET or 625MHz for Ethernet applications.

Internally, the exact APLL feedback divider value is expressed in the form  $AFBDIV + AFBREM / AFBDEN * 2^{-(33-AFBBP)}$ . This feedback divider value must be chosen such that  $APLL\_input\_frequency * feedback\_divider\_value$  is in the operating range of the VCO (as specified in [Table 12](#)). The [AFBDIV](#) term is a fixed-point number with 9 integer bits and a configurable number of fractional bits (up to 33, as specified by [AFBBP](#)). Typically [AFBBP](#) is set

to 9 to specify that **AFBDIV** has  $33 - 9 = 24$  fractional bits. Using more than 24 fractional bits does not yield a detectable benefit. Using less than 12 fractional bits is not recommended.

The following equations show how to calculate the feedback divider values for the situation where the APLL should multiply the APLL input frequency by integer M and also fractionally scale by the ratio of integers N / D. In other words,  $VCO\_frequency = input\_frequency * M * N / D$ . An example of this is multiplying 77.76MHz by  $M=48$  and scaling by  $N / D = 255 / 237$  for forward error correction applications.

$$AFBDIV = \text{trunc}(M * N / D * 2^{24}) \quad (1)$$

$$lsb\_fraction = M * N / D * 2^{24} - AFBDIV \quad (2)$$

$$AFBDEN = D \quad (3)$$

$$AFBREM = \text{round}(lsb\_fraction * AFBDEN) \quad (4)$$

$$AFBBP = 33 - 24 = 9 \quad (5)$$

The `trunc()` function returns only the integer portion of the number. The `round()` function rounds the number to the nearest integer. In Equation (1), **AFBDIV** is set to the full-precision feedback divider value,  $M * N / D$ , truncated after the 24<sup>th</sup> fractional bit. In Equation (2) the temporary variable 'lsb\_fraction' is the fraction that was truncated in Equation (1) and therefore is not represented in the **AFBDIV** value. In Equation (3), **AFBDEN** is set to the denominator of the original  $M * N / D$  ratio. In Equation (4), **AFBREM** is calculated as the integer numerator of a fraction (with denominator **AFBDEN**) that equals the 'lsb\_fraction' temporary variable. Finally, in Equation (5) **AFBBP** is set to  $33 - 24 = 9$  to correspond with **AFBDIV** having 24 fractional bits.

When a fractional scaling scenario involves multiplying an integer M times multiple scaling ratios  $N_1 / D_1$  through  $N_n / D_n$ , the equations above can still be used if the numerators are multiplied together to get  $N = N_1 * N_2 * \dots * N_n$  and the denominators are multiplied together to get  $D = D_1 * D_2 * \dots * D_n$ .

The easiest way to calculate the exact values to write to the APLL registers is to use the ZL3025x evaluation software, available on the Microsemi website. This software can be used even when no evaluation board is attached to the computer.

Note: After the APLL's feedback divider settings are configured in register fields **AFBDIV**, **AFBREM**, **AFBDEN** and **AFBBP**, the APLL enable bit **PLLEN**.APLLEN should be changed from 0 to 1 to cause the APLL to reacquire lock with the new settings. The real-time lock/unlock status of the APLL is indicated by **APLLSR**.ALK and ALK2.

### 5.6.3 APLL Phase Adjustment

The phase of the APLL's output clock can be incremented or decremented by 1/8<sup>th</sup> of a VCO cycle. This phase step size is 30ps at maximum VCO frequency of 4180MHz and 33.7ps at minimum VCO frequency of 3715MHz. The **APLLCR4**.PDSS field specifies the phase decrement control signal, which can be the **APLLCR4**.DECPH bit or any of the four GPIOs. The **APLLCR4**.PISS field specifies the phase increment control signal, which can be the **APLLCR4**.INCPH bit or any of the four GPIOs. Phase is adjusted on every rising edge and every falling edge of the control signal. This phase adjustment affects the output of both high-speed dividers.

## 5.7 Output Clock Configuration

The device has three output clock signal pairs. Each output has individual divider, enable and signal format controls. In CMOS mode each signal pair can become two CMOS outputs, allowing the device to have up to six output clock signals. Also in CMOS mode, the OCxN pin can have an additional divider allowing the OCxN frequency to be an integer divisor of the OCxP frequency (example: OC3P 125MHz and OC3N 25MHz). The outputs can be aligned relative to each other and relative to an input signal, and the phases of output signals can be adjusted dynamically with high resolution and infinite range.

### 5.7.1 Output Enable, Signal Format, Voltage and Interfacing

To use an output, the output driver must be enabled by setting `OCxCR2.OCSF≠0`, and the per-output dividers must be enabled by setting the appropriate bit in the `OCEN` register. The per-output dividers include the medium-speed divider, the low-speed divider and the associated phase adjustment/alignment circuitry and start/stop logic.

Using the `OCxCR2.OCSF` register field, each output pair can be disabled or configured as a CML output, an HSTL output, or one or two CMOS outputs. When an output is disabled it is high impedance, and the output driver is in a low-power state. In CMOS mode, the `OCxN` pin can be disabled, in phase or inverted vs. the `OCxP` pin. In CML mode the normal 800mV  $V_{OD}$  differential voltage is available as well as a half-swing 400mV  $V_{OD}$ . All of these options are specified by `OCxCR2.OCSF`. The clock to the output driver can be inverted by setting `OCxCR2.POL=1`. The CMOS/HSTL output driver can be set to any of four drive strengths using `OCxCR2.DRIVE`.

Each output has its own power supply pin to allow CMOS or HSTL signal swing from 1.5V to 3.3V for glueless interfacing to neighboring components. If `OCSF` is set to HSTL mode then a 1.5V power supply voltage should be used to get a standards-compliant HSTL output. Note that differential (CML) outputs must have a power supply of 3.3V.

The differential outputs can be easily interfaced to LVDS, LVPECL, CML, HCSL, HSTL and other differential inputs on neighboring ICs using a few external passive components. See [Figure 18](#) for examples.

### 5.7.2 Output Frequency Configuration

The frequency of each output is determined by the configuration of the APLL, the high-speed dividers and the per-output dividers. Each output can be connected to either high-speed divider 1 (`HSDIV1`) or 2 (`HSDIV2`) using the `OCxCR3.DIVSEL` field.

Each output has two output dividers, a 7-bit medium-speed divider (`OCxCR1.MSDIV`) and a 25-bit low-speed output divider (`LSDIV` field in the `OCxDIV` registers). These dividers are in series, medium-speed divider first then output divider. These dividers produce signals with 50% duty cycle for all divider values including odd numbers. The low-speed divider can only be used if the medium-speed divider is used (i.e. `OCxCR1.MSDIV>0`). The maximum input frequency to the medium-speed divider is 850MHz. The maximum input frequency to the low-speed divider is 425MHz.

Since each output has its own independent dividers, the device can output families of related frequencies that have an APLL `HSDIV` output frequency as a common multiple. For example, for Ethernet clocks, a 625MHz `HSDIV` output clock can be divided by four for one output to get 156.25MHz, divided by five for another output to get 125MHz, and divided by 25 for another output to get 25MHz. Similarly, for SDH/SONET clocks, a 622.08MHz `HSDIV` output clock can be divided by 4 to get 155.52MHz, by 8 to get 77.76MHz, by 16 to get 38.88MHz or by 32 to get 19.44MHz.

#### Two Different Frequencies in 2xCMOS Mode

When an output is in 2xCMOS mode it can be configured to have the frequency of the `OCxN` clock be an integer divisor of the frequency of the `OCxP` clock. Examples of where this can be useful:

- 125MHz on `OCxP` and 25MHz on `OCxN` for Ethernet applications
- 77.76MHz on `OCxP` and 19.44MHz on `OCxN` for SONET/SDH applications
- 25MHz on `OCxP` and 1Hz (i.e. 1PPS) on `OCxN` for telecom applications with Synchronous Ethernet and IEEE1588 timing

An output can be configured to operate like this by setting the `LSDIV` value in the `OCxDIV` registers to `OCxP_freq / OCxN_freq - 1` and setting `OCxCR3.LSSEL=0` and `OCxCR3.NEGLSD=1`. Here are some notes about this dual-frequency configuration option:

- In this mode only the medium speed divider is used to create the OCxP frequency. The low-speed divider is then used to divide the OCxP frequency down to the OCxN frequency. This means that the lowest OCxP frequency is the high-speed divider output frequency divided by 128.
- An additional constraint is that the medium-speed divider must be configured to divide by 6 or more (i.e. must have `OCxCR1.MSDIV $\geq$ 5`).

### 5.7.3 Output Duty Cycle Adjustment

For output frequencies less than or equal to 141.666MHz, the duty cycle of the output clock can be modified using the `OCxDC.OCDC` register field. This behavior is only available when `MSDIV $>$ 0` and `LSDIV  $>$  1`. When `OCDC = 0` the output clock is 50%. Otherwise the clock signal is a pulse with a width of `OCDC` number of `MSDIV` output clock periods. The range of `OCDC` can create pulse widths of 1 to 255 `MSDIV` output clock periods. When `OCxCR2.POL=0`, the pulse is high and the signal is low the remainder of the cycle. When `POL=1`, the pulse is low and the signal is high the remainder of the cycle.

Note that duty cycle adjustment is done in the low-speed divider. Therefore when `OCxCR3.LSSEL=0` the duty cycle of the output is not affected. Also, when a CMOS output is configured with `OCxCR3.LSSEL=0` and `OCxCR3.NEGLSD=1`, the OCxN pin has duty cycle adjustment but the OCxP pin does not. This allows a higher-speed 50% duty cycle clock signal to be output on the OCxP pin and a lower-speed frame/phase/time pulse (e.g. 2kHz, 8kHz or 1PPS) to be output on the OCxN pin at the same time.

An output configured for CMOS or HSTL signal format should not be configured to have a duty cycle with high time shorter than 2ns or low time shorter than 2ns.

### 5.7.4 Output Phase Adjustment and Phase Alignment

The device has flexible, high-resolution tools for managing the phases of the output clocks relative to one another. The key register fields for this are found in the `PACR1` and `PACR2` global configuration registers and the per-output `OCxPH` register.

Phase alignment and phase adjustment are done in the medium-speed dividers. Resolution is 0.5 periods (also known as unit intervals or UI) of the high-speed divider (`HSDIV`) output clock. For example, for an `HSDIV` output frequency of 800MHz, resolution is 625ps.

#### 5.7.4.1 Phase Adjustment

A phase adjustment is a phase change for an output relative to that output's most recent phase. To cause the device to perform phase adjustment of an output clock, set `PACR1.MODE=1`, set `OCxCR1.PHEN=1` to enable the output for phase adjustment, and write the phase adjustment amount to the output's `OCxPH` register. Then an arm/trigger methodology is used to cause the phase adjustment to happen.

The arm step tells the device that it is enabled to perform the phase adjustment when it sees the trigger stimulus. The source of the arm signal is specified by `PACR2.ARMSRC`. Options include the 0-to-1 transition of the `PACR1.ARM` bit, APLL transition from unlocked to locked, or a transition on one of the GPIO pins.

The source of the trigger signal is specified by `PACR2.TRGSRC`. Options include 0-to-1 transition of the `PACR1.TRIG` bit, APLL transition from unlocked to locked, or a transition on one of the GPIO pins. The trigger signal can be inverted by setting `PACR1.TINV`. With `TINV=1`, the same GPIO signal can arm on one edge and trigger on the opposite edge.

Any combination of outputs can be phase adjusted by the same trigger, and each output can be adjusted by a different amount. Only outputs with `OCxCR1.PHEN=1` and `OCxPH.PHADJ $\neq$ 0` have their phases adjusted.

There are a few constraints on the range of possible phase adjustments. These have to do with the output's medium-speed divider value.

- 1) Phase adjustment is not available unless `OCxCR1.MSDIV>0`.
- 2) The largest negative phase adjustment magnitude in HSDIV periods is:  
 If `OCxCR1.MSDIV` is odd:  $(OCxCR1.MSDIV - 1) / 2$   
 If `OCxCR1.MSDIV` is even:  $(OCxCR1.MSDIV - 2) / 2$
- 3) The largest positive phase adjustment in HSDIV periods is:  
 If `OCxCR1.MSDIV` is odd:  $(127 - OCxCR1.MSDIV) / 2$   
 If `OCxCR1.MSDIV` is even:  $(128 - OCxCR1.MSDIV) / 2$

The implications of constraints 2) and 3) are shown in this table:

<b>OCxCR1.MSDIV</b>	<b>Largest Negative Phase Adjust, HSDIV periods</b>	<b>Largest Positive Phase Adjust, HSDIV periods</b>	<b>Notes</b>
1 or 2	0	63	no negative adjustment
3 or 4	1	62	
5 or 6	2	61	
...	...	...	
123 or 124	61	2	
125 or 126	62	1	
127	63	0	no positive adjustment

During a phase adjustment the MSDIV output period is changed for one period. The MSDIV output signal during that period will have longer high time (unless inverted) during a positive phase adjustment and shorter high time (unless inverted) during a negative phase adjustment. With negative phase adjustments care must be taken to not shorten the high time of the output clock signal to be too short for the components that receive the clock. There are several possible ways to avoid this issue including: (1) using small negative adjustments such as  $-0.5UI$  repeatedly instead of one larger negative adjustment, (2) using positive adjustments to “wrap around” to the desired negative adjustment, or (3) holding the components that receive the clock in reset during the phase adjustment.

An armed phase adjustment can be canceled before the trigger occurs by setting the `PACR1.RST` bit.

The `PASR` register has real-time status bits indicating whether a phase adjustment is armed and waiting for a trigger (ARMED bit) or in progress (BUSY bit). It also has a latched status bit (ADJL bit) to indicate the adjustment has completed.

**Example:** +1.0 HSDIV period phase adjustment for output OC1 using ARM and TRIG register bits:

```

OC1CR1.PHEN=1           (Enable phase adjust on OC1)
OC1PH.PHADJ=00000010   (Specify +1.0 HSDIV period phase adjustment)
PACR1.MODE=1           (Phase adjustment mode)
PACR2.ARMSRC=0001      (arm signal is PACR1.ARM bit)
PACR2.TRGSRC=0000      (trigger signal is PACR1.TRIG bit)
PACR1.RST=1            (reset phase adjust/align state machine after changing ARMSRC)
PACR1.ARM=1            (arm for phase adjust)
PACR1.TRIG=1           (do the phase adjust: add +1.0 UI to output phase)
repeat the next two writes as needed:
PACR1.ARM=1 .TRIG=0    (arm again; clearing the TRIG bit is required when MSDIV period < master
                        clock period because TRIG is not self-clearing in this situation)
PACR1.TRIG=1           (add +1.0 UI to output phase again)
    
```

#### 5.7.4.2 Phase Alignment, Output-to-Output

A phase alignment is a special case of phase adjustment where the MSDIV and LSDIV dividers for all participating outputs are reset just before the phase adjustment occurs. For output-to-output alignment the trigger can be the `PACR1.TRIG` bit or the APLL lock signal.

To avoid glitches (i.e. “runt pulses”) on the output clock it is possible to manually stop the output(s), before triggering the phase alignment, and then restart the output(s) after the alignment (See section 5.7.5).

When aligning outputs, it is important to note that, by default, the phase of outputs configured as HSTL format or “two CMOS, OCxP inverted vs. OCxN” format is opposite that of CML outputs. For example, consider the case where OC1 is 100MHz CML format and OC2 is 100MHz HSTL format. When OC1 and OC2 are aligned then OC2N is high when OC1P is high. The polarity bit OCxCR2.POL can be used to change this as needed.

There are several rules when alignment is enabled for multiple outputs:

- All participating outputs must come from the same high-speed divider
- All outputs that use both medium-speed and low-speed divider must have the same MSDIV value, the same LSDIV value and PHADJ=0. Subsequent phase adjustment(s) can be used to move the output(s) to other phase(s).
- All outputs that only use medium-speed divider can have PHADJ values smaller than the period of the highest output frequency among them.
- When some outputs use only medium-speed divider and other outputs use both medium-speed and low-speed divider, all MSDIV values must be the same, and those output using low-speed divider must have PHADJ=0.

Contact Microsemi Timing Applications Support for help with alignment scenarios that don’t meet the rules listed above.

**Example:** OC1-to-OC2 alignment (+3.5 HSDIV UI offset) after the APLL locks:

```

OC1CR1.PHEN=1      (Enable phase adjust on OC1)
OC2CR1.PHEN=1      (Enable phase adjust on OC2)
OC1PH.PHADJ=00000000 (0.0UI)
OC2PH.PHADJ=00000111 (+3.5UI)
PACR1.MODE=0       (Phase alignment mode)
PACR2.ARMSRC=0001  (arm signal is PACR1.ARM bit)
PACR2.TRGSRC=0001  (trigger signal is APLL transition from unlocked to locked)
PACR1.RST=1        (reset phase adjust/align state machine after changing ARMSRC, TRGSRC)
PACR1.ARM=1        (arm for phase alignment)
(Aligns/realigns outputs when the APLL locks or relocks)

```

### 5.7.4.3 Phase Alignment, Input-to-Output

The phase alignment tool described in section 5.7.4.2 can use a GPIO pin as the alignment trigger. However there is some uncertainty associated with sampling the GPIO signal. Therefore the phase alignment tool *by itself* is not sufficient to achieve input-to-output phase alignment. The procedure is to first do a phase alignment as described in section 5.7.4.2 but with a GPIO input as the trigger. Then the phase measurement tool described in section 5.7.6 can be used to determine the phase difference between an output signal and the input signal. Then phase adjustment as described in section 5.7.4.1 can be used to change the phase of one or more output signals to align with input signal phase.

It is important to note that, by default, outputs that only use the medium-speed divider have their rising edge aligned with the rising edge of the trigger signal. Meanwhile, outputs that use both the medium-speed and low-speed dividers have their rising edge aligned with the falling edge of the trigger signal. Per-output polarity bits (OCxCR2.POL) can be used to invert the polarity of output signals as needed so that all are rising-edge aligned or falling-edge aligned or any combination as needed.

### 5.7.5 Output Clock Start and Stop

Output clocks can be stopped high or low. One use for this behavior is to ensure “glitchless” output clock operation while the output is reconfigured or phase aligned with some other signal.

Each output has an **OCxSTOP** register with fields to control this behavior. The **OCxSTOP.MODE** field specifies whether the output clock signal stops high, stops low, or does not stop. The **OCxSTOP.SRC** field specifies the source of the stop signal. Options include the **OCxSTOP.STOP** bit, assertion of one of the GPIO pins, and the arming of a phase adjustment (which is indicated by **PASR.ARMED**).

When the stop mode is Stop High (**OCxSTOP.MODE=01**) and the stop signal is asserted, the output clock is stopped after the next rising edge of the output clock. When the stop mode is Stop Low (**OCxSTOP.MODE=10**) and the stop signal is asserted, the output clock is stopped after the next falling edge of the output clock. Internally the clock signal continues to toggle while the output is stopped. When the stop signal is deasserted, the output clock resumes on the opposite edge that it stopped on. Low-speed output clocks can take long intervals before being stopped after the stop signal goes active. For example, a 1 Hz output could take up to 1 second to stop.

**OCxCR1.MSDIV** must be > 0 for this function to operate since **MSDIV=0** bypasses the start-stop circuits. Note that when **OCxCR3.NEGLSD=1** the start-stop logic is bypassed for the **OCxN** pin, and **OCxN** may not start/stop without glitches.

When **OCxCR2.POL=1** the output stops on the opposite polarity that is specified by the **OCxSTOP.MODE** field.

When **OCxCR2.STOPDIS=1** the output driver is disabled (high impedance) while the output clock is stopped.

Each output has a status register (**OCxSR**) with several stop/start status bits. The **STOPD** bit is a real-time status bit indicating stopped or not stopped. The **STOPL** bit is a latched status bit that is set when the output clock has stopped. The **STARTL** bit is a latched status bit that is set when the output clock has started.

### 5.7.6 A-to-B Phase Offset Measurement

The phase or time offset between two signals (A and B) can be measured in units of a timebase clock. This capability can be used to for several purposes, including:

- Keeping output clocks and low-speed output phase/time signals—such as frame sync, multiframe sync, or 1 pulse per second (1PPS) signals—aligned with input phase/time signals. The A-to-B measurement circuitry can detect phase changes in the input signal. Then the output phase adjustment circuitry described in section 5.7.4 can be used to move phase(s) of output(s) to follow the input phase change.
- Keeping output clock signals and/or low-speed output phase/time signals aligned with one another. The A-to-B measurement circuitry can detect relative phase changes, and the phase adjustment circuitry described in section 5.7.4 can be used to move phase(s) of output(s) as needed.

The A and B signals can be any **ICx** input, any **OCx** output, or any **GPIO**, as specified by **MABCR2.ASRC** and **MABCR3.BSRC**. The timebase signal can be the external oscillator signal (or the output of the crystal driver circuit, optionally doubled by the clock doubler) or the output clock of any of the three medium-speed dividers (**MSDIV1**, **MSDIV2**, **MSDIV3**). The timebase signal is specified by **MABCR1.TBSRC**.

A new measurement is started by writing **MABCR1.START=1**. Any previously started measurement must be completed before a new measurement is started. If a measurement has not finished it can be aborted by writing **MABCR1.RST=1** before starting a new measurement. The measurement is complete when **MABSR1.RDYL** is set.

**Example:** consider an SDH/SONET application where **OC1** is a 19.44MHz output clock and **OC2** is an 8kHz frame sync signal. The goal is to measure the phase offset of **OC1** vs. **OC2**. If they are found to have a phase offset then the phase adjustment circuitry in section 5.7.4 can be used to slowly change the phase of **OC1** to match the phase of **OC2** (or vice versa).

<b>MABCR1.TBSRC=001</b>	( <b>MSDIV1</b> output clock is 311.04MHz = 3.2 ns period)
<b>MABCR2.ASRC=10001</b>	( <b>OC2</b> 8kHz sync signal)
<b>MABCR3.BSRC=10000</b>	( <b>OC1</b> 19.44MHz clock)
<b>MABCR1.START=1</b>	(Start measurement)
Wait for <b>MABSR1.RDYL=1</b>	(Measurement ready)

Read `MABSR1.OVFL` (to see if the measurement is valid)  
`MABSR1.RDYL=1, MABSR1.OVFL=1` (clear latched status bits)  
 Read MEAS bits from `MABSR1`  
 and `MABSR2`

If, for example, MEAS = 111 1111 1001 (-8) then the rising edge of OC1 (the 'B' signal) precedes the rising edge of OC2 (the 'A' signal) by 8 MSDIV1 output clock periods (25.7ns).

An A-to-B measurement is performed by sampling the A and B signals with the selected timebase clock and detecting the rising or falling edges to measure. The number of timebase clocks between the A and B edges is counted. If the counter doesn't overflow then the phase difference is reported in the MEAS field in `MABSR1` and `MABSR2`. If the counter does overflow then `MABSR1.OVFL` is set and the value of MEAS is invalid.

While the measurement is in progress the `MABSR1.BUSY` bit is set to 1. When the measurement is complete `MABSR1.BUSY` is set to 0 and `MABSR1.RDYL` is set to 1. Since the A and B signals are sampled by the timebase signal, this measurement tool is only useful when the timebase signal is much higher frequency than the A and B signals (at least 8-10x). Also, when possible, the timebase signal frequency should be less than or equal to 1000 times faster than the the frequencies of the A and B frequencies to avoid measurement counter overflow.

Constraints on A-to-B measurement:

- $f_B = f_A \times N$  where  $f_A$  is the frequency of signal A,  $f_B$  is the frequency of signal B and N is a positive integer

When measuring from an ICx input or a GPIO (signal A) to an ICx or a GPIO (signal B) and when measuring from an OCx output to an OCx output, the measured value is MEAS \* timebase\_period. This measurement has a variability of 0 to +1 timebase clock period.

When measuring from an ICx input or a GPIO (signal A) to an OCx output (signal B), the measurement in time units is MEAS \* timebase\_period + 6 \* HSCLK\_period, where HSCLK\_period is the period of the output of the high-speed divider from which OCx signal is derived. This measurement has a variability of 0 to +1 timebase clock period plus 0 to +1 HSCLK periods.

When measuring from an OCx output (signal A) to an ICx input or a GPIO (signal B), the the measurement in time units is MEAS \* timebase\_period - 6 \* HSCLK\_period, where HSCLK\_period is the period of the output of the high-speed divider from which OCx signal is derived. This measurement has a variability of 0 to +1 timebase clock period plus 0 to +1 HSCLK periods.

### Guidance for Use

When the A and B signals are aligned to within one timebase clock cycle, the measurement hardware does not report 0. Instead it reports a measurement value that is equivalent to +1 cycle of signal B.

If the timebase clock is  $\leq 1023$  times faster than signal B (so that the MEAS field cannot overflow, unless signal B is grossly too slow or not toggling at all) then system software should check the measured phase value. If the measured value is equal to the period of signal B then the A and B signals are aligned.

If the timebase clock is 1024 to 2047 times faster than signal B (and therefore the measurement counter can overflow) then the measurement hardware reports overflow when the A and B signals are aligned to within one timebase clock cycle. This report of overflow can be distinguished from other overflow cases by setting `MABCR3.BINV=1` and then remeasuring from signal A to the opposite edge of signal B. If the new measured value is equal to half the period of signal B then the A and B signals are aligned.

If the timebase clock is  $> 2047$  times faster than signal B then the measurement hardware reports overflow when the A and B signals are aligned to within one timebase clock cycle. This report of overflow is not distinguishable from other overflow cases. One way system software could work around this to determine that A and B are aligned

is to use phase adjustment to move one of the signals by 2 or more timebase clocks then remeasure. If the new measured value matches the phase adjustment then the signals were aligned before the phase adjustment. Software can then adjust the phase of the signal back to its original position. Not all applications can tolerate such phase adjustments; for those applications it is recommended that the timebase clock be  $\leq 2047$  times faster than signal B.

## 5.8 Microprocessor Interface

The device can communicate over a SPI interface or an I<sup>2</sup>C interface.

In SPI mode the ZL30250 can be configured at reset to be a SPI slave to a processor master or a SPI master to an external EEPROM slave. The ZL30251 can only be configured as a SPI slave to a processor master. Both devices are always slaves on the I<sup>2</sup>C bus.

Section 5.2 describes reset pin settings required to configure the device for these interfaces.

### 5.8.1 SPI Slave

The device can present a SPI slave port on the CSN, SCLK, MOSI, and MISO pins. SPI is a widely used master/slave bus protocol that allows a master and one or more slaves to communicate over a serial bus. SPI masters are typically microprocessors, ASICs or FPGAs. Data transfers are always initiated by the master, which also generates the SCLK signal. The device receives serial data on the MOSI (Master Out Slave In) pin and transmits serial data on the MISO (Master In Slave Out) pin. MISO is high impedance except when the device is transmitting data to the bus master.

**Bit Order.** The register address and all data bytes are transmitted most significant bit first on both MOSI and MISO.

**Clock Polarity and Phase.** The device latches data on MOSI on the rising edge of SCLK and updates data on MISO on the falling edge of SCLK. SCLK does not have to toggle between accesses, i.e., when CSN is high.

**Device Selection.** Each SPI device has its own chip-select line. To select the device, the bus master drives its CSN pin low.

**Command and Address.** After driving CSN low, the bus master transmits an 8-bit command followed by a 16-bit register address. The available commands are shown below.

**Table 3 – SPI Commands**

Command	Hex	Bit Order, Left to Right
Write Enable	0x06	0000 0110
Write	0x02	0000 0010
Read	0x03	0000 0011
Read Status	0x05	0000 0101

**Read Transactions.** The device registers are accessible when **EESEL**=0. On a ZL30251 the internal EEPROM memory is accessible when **EESEL**=1. On a ZL30250 **EESEL** must be set to 0. After driving CSN low, the bus master transmits the read command followed by the 16-bit address. The device then responds with the requested data byte on MISO, increments its address counter, and prefetches the next data byte. If the bus master continues to demand data, the device continues to provide the data on MISO, increment its address counter, and prefetch the following byte. The read transaction is completed when the bus master drives CSN high. See [Figure 7](#).

**Register Write Transactions.** The device registers are accessible when **EESEL**=0. After driving CSN low, the bus master transmits the write command followed by the 16-bit register address followed by the first data byte to be written. The device receives the first data byte on MOSI, writes it to the specified register, increments its internal address register, and prepares to receive the next data byte. If the master continues to transmit, the device continues to write the data received and increment its address counter. The write transaction is completed when the bus master drives CSN high. See [Figure 9](#).

**EEPROM Writes (ZL30251 Only).** The internal EEPROM memory is accessible when **EESEL**=1. After driving CSN low, the bus master transmits the write enable command and then drives CSN high to set the internal write enable latch. The bus master then drives CSN low again and transmits the write command followed by the 16-bit address followed by the first data byte to be written. The device first copies the page to be written from EEPROM to

its page buffer. The device then receives the first data byte on MOSI, writes it to its page buffer, increments its internal address register, and prepares to receive the next data byte. If the master continues to transmit, the device continues to write the data received to its page buffer and continues to increment its address counter. The address counter rolls over at the 32-byte page boundary (i.e. when the five least-significant address bits are 11111). When the bus master drives CSN high, the device transfers the data in the page buffer to the appropriate page in the EEPROM memory. See [Figure 8](#) and [Figure 9](#).

**EEPROM Read Status (ZL30251 Only).** After the bus master drives CSN high to end an EEPROM write command, the EEPROM memory is not accessible for up to 5ms while the data is transferred from the page buffer. To determine when this transfer is complete, the bus master can use the Read Status command. After driving CSN low, the bus master transmits the Read Status command. The device then responds with the status byte on MISO. In this byte, the least significant bit is set to 1 if the transfer is still in progress and 0 if the transfer has completed.

**Early Termination of Bus Transactions.** The bus master can terminate SPI bus transactions at any time by pulling CSN high. In response to early terminations, the device resets its SPI interface logic and waits for the start of the next transaction. If a register write transaction is terminated prior to the SCLK edge that latches the least significant bit of a data byte, the data byte is not written. On ZL30251, if an EEPROM write transaction is terminated prior to the SCLK edge that latches the least significant bit of a data byte, none of the bytes in that write transaction are written.

**Design Option: Wiring MOSI and MISO Together.** Because communication between the bus master and the device is half-duplex, the MOSI and MISO pins can be wired together externally to reduce wire count. To support this option, the bus master must not drive the MOSI/MISO line when the device is transmitting.

**AC Timing.** See [Table 17](#) and [Figure 20](#) for AC timing specifications for the SPI interface.

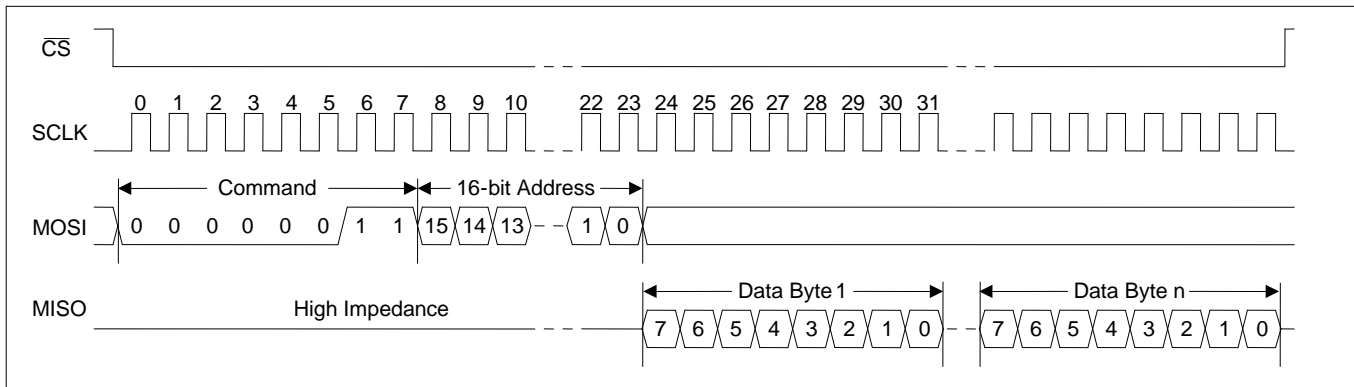

Figure 7 - SPI Read Transaction Functional Timing

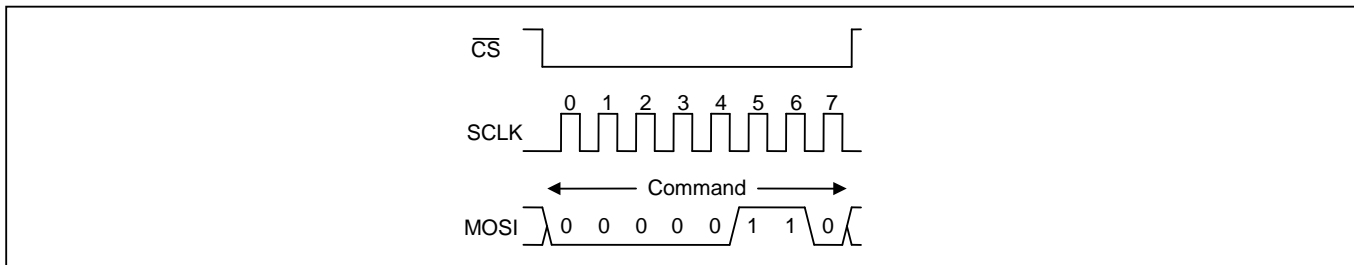

Figure 8 - SPI Write Enable Transaction Functional Timing (ZL30251 Only)

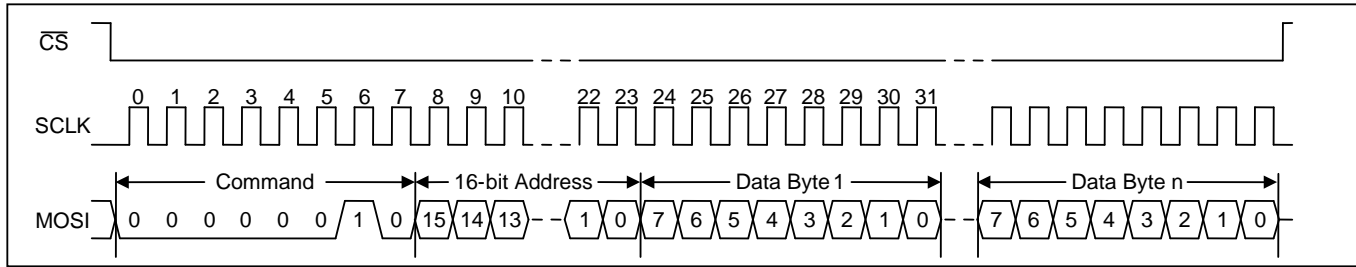

Figure 9 - SPI Write Transaction Functional Timing

**5.8.2 SPI Master (ZL30250 Only)**

After reset the ZL30250 can present a SPI master port on the CSN, SCLK, MOSI, and MISO pins for auto-configuration using data read from an external SPI EEPROM. During auto-configuration the device is always the SPI master and generates the CSN and SCLK signals. The device transmits serial data on the the MOSI (Master Out Slave In) pin and receives serial data on the MISO (Master In Slave Out) pin.

**Bit Order.** The register address and all data bytes are transmitted most significant bit first on both MOSI and MISO.

**Clock Polarity and Phase.** The device latches data on MISO on the rising edge of SCLK and updates data on MOSI on the falling edge of SCLK.

**Device Selection.** Each SPI device has its own chip-select line. To select the external EEPROM, the device drives the CSN signal low.

**Command and Address.** After driving CSN low, the device transmits an 8-bit read command followed by a 16-bit register address. The read command is shown below.

Command	Hex	Bit Order, Left to Right
Read	0x03	0000 0011

**Read Transactions.** After driving CSN low, the device transmits the read command followed by the 16-bit register address. The external EEPROM then responds with the requested data byte on MISO, increments its address counter, and prefetches the next data byte. If the device continues to demand data, the EEPROM continues to provide the data on MISO, increment its address counter, and prefetch the following byte. The read transaction is completed when the device drives CSN high. See [Figure 7](#).

**Writing the External EEPROM.** Due to the small package size and low pin count of the device, there is no way to use the ZL30250 to write the external EEPROM. The auto-configuration data used by the ZL30250 must be pre-programmed into the EEPROM by some other method, such as:

1. The EEPROM manufacturer can write the data to the EEPROM during production testing. This is a service they routinely provide.
2. A contract manufacturer or distributor can write the data to the EEPROM using a production EEPROM programmer before the EEPROM is mounted to the board.

### 5.8.3 I<sup>2</sup>C Slave

The device can present a fast-mode (400kbit/s) I<sup>2</sup>C slave port on the SCL and SDA pins. I<sup>2</sup>C is a widely used master/slave bus protocol that allows one or more masters and one or more slaves to communicate over a two-wire serial bus. I<sup>2</sup>C masters are typically microprocessors, ASICs or FPGAs. Data transfers are always initiated by the master, which also generates the SCL signal. The device is compliant with version 2.1 of the I<sup>2</sup>C specification.

The I<sup>2</sup>C interface on the device is a protocol translator from external I<sup>2</sup>C transactions to internal SPI transactions. This explains the slightly increased protocol complexity described in the paragraphs that follow.

**Read Transactions.** The device registers are accessible when `EESEL=0`. On a ZL30251 the internal EEPROM memory is accessible when `EESEL=1`. On ZL30250 `EESEL` must be set to 0. The bus master first does an I<sup>2</sup>C write to the device. In this transaction three bytes are written: the SPI Read command (see [Table 3](#)), the upper byte of the register address, and the lower byte of the register address. The bus master then does an I<sup>2</sup>C read. During each acknowledge (A) bit the device fetches data from the read address and then increments the read address. The device then transmits the data to the bus master during the next 8 SCL cycles. The bus master terminates the read with a not-acknowledge (NA) followed by a STOP condition (P). See [Figure 10](#). Note: If the I<sup>2</sup>C write is separated in time from the I<sup>2</sup>C read by other I<sup>2</sup>C transactions then the device only outputs the data value from the first address and repeats that same data value after each acknowledge (A) generated by the bus master.

**Register Write Transactions.** The device registers are accessible when `EESEL=0`. The bus master does an I<sup>2</sup>C write to the device. The first three bytes of this transaction are the SPI Write command (see [Table 3](#)), the upper byte of the register address, and the lower byte of the register address. Subsequent bytes are data bytes to be written. After each data byte is received, the device writes the byte to the write address and then increments the write address. The bus master terminates the write with a STOP condition (P). See [Figure 11](#).

**EEPROM Writes (ZL30251 Only).** The EEPROM memory is accessible when `EESEL=1`. The bus master first does an I<sup>2</sup>C write to transmit the SPI Write Enable command (see [Table 3](#)) to the device. The bus master then does an I<sup>2</sup>C write to transmit data to the device as described in the Register Write Transactions paragraph above. See [Figure 12](#).

**EEPROM Read Status (ZL30251 Only).** The bus master first does an I<sup>2</sup>C write to transmit the SPI Read Status command (see [Table 3](#)) to the device. The bus master then does an I<sup>2</sup>C read to get the status byte. In this byte, the least significant bit is set to 1 if the transfer is still in progress and 0 if the transfer has completed. See [Figure 13](#).

**I<sup>2</sup>C Features Not Supported by the Device.** The I<sup>2</sup>C specification has several optional features that are not supported by the device. These are: 3.4Mbit/s high-speed mode (Hs-mode), 10-bit device addressing, general call address, software reset, and device ID. The device does not hold SCL low to force the master to wait.

**I<sup>2</sup>C Slave Address.** The device's 7-bit slave address can be pin-configured for any of three values. These values are show in the table in section [5.2](#).

**Bit Order.** The I<sup>2</sup>C specification requires device address, register address and all data bytes to be transmitted most significant bit first on the SDA signal.

Note: as required by the I<sup>2</sup>C specification, when power is removed from the device, the SDA and SCL pins are left floating so they don't obstruct the bus lines.

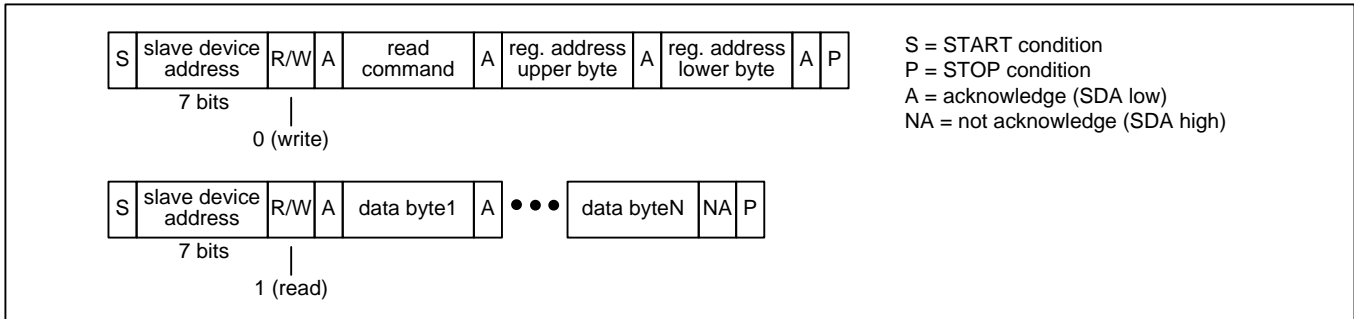

Figure 10 – I<sup>2</sup>C Read Transaction Functional Timing

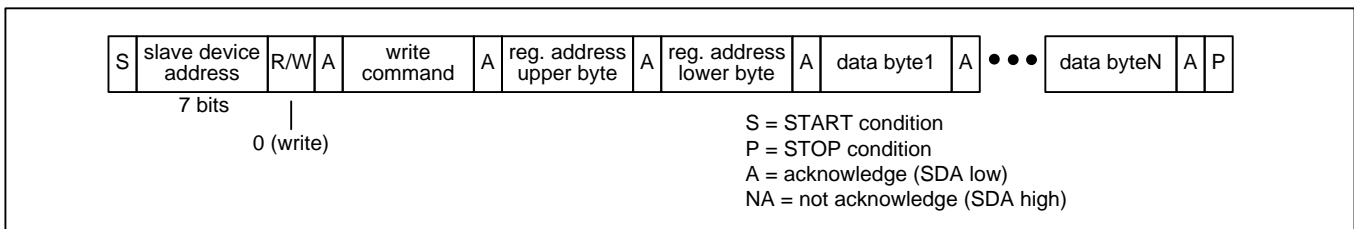

Figure 11 – I<sup>2</sup>C Register Write Transaction Functional Timing

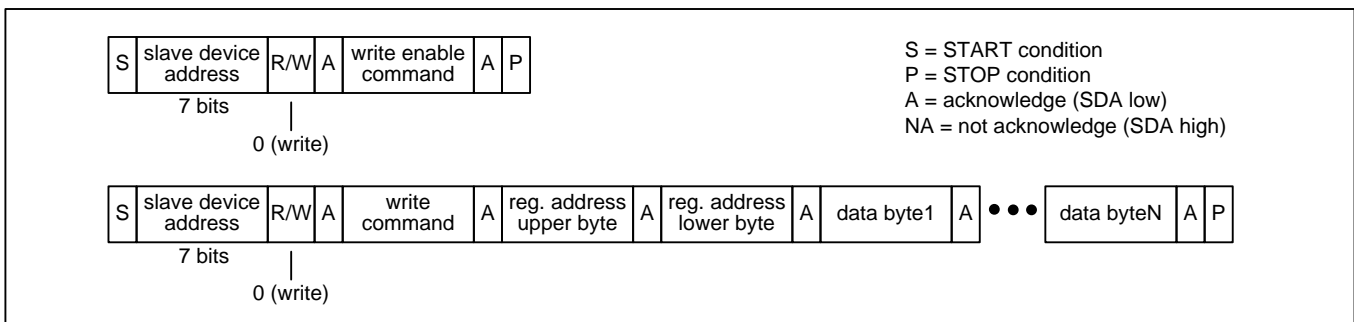

Figure 12 – I<sup>2</sup>C EEPROM Write Transaction Functional Timing (ZL30251 Only)

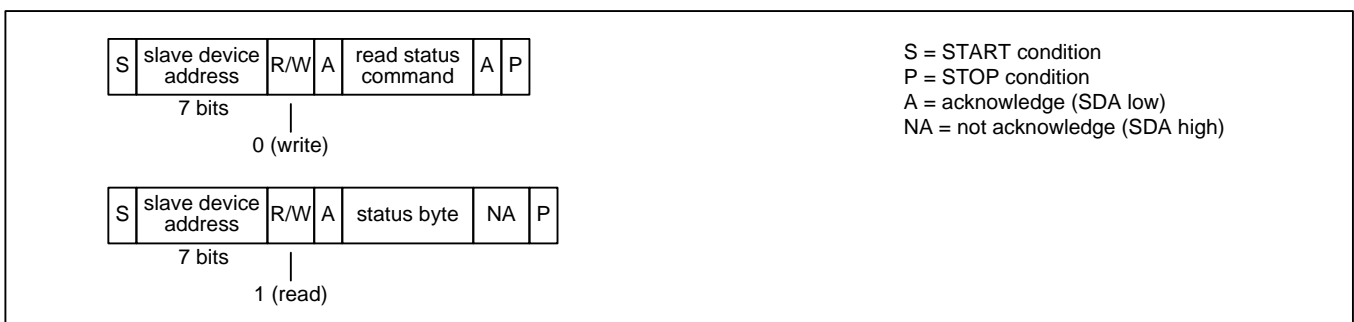

Figure 13 – I<sup>2</sup>C EEPROM Read Status Transaction Functional Timing (ZL30251 Only)

Note: In Figure 10 through Figure 13, a STOP condition (P) immediately followed by a START condition (S) can be replaced by a repeated START condition (Sr) as described in the I<sup>2</sup>C specification.

### 5.9 Interrupt Logic

Any of the GPIO pins can be configured as an interrupt-request output by setting the appropriate GPIOxC field in the GPIOCR registers to one of the status output options (01xx) and configuring the appropriate GPIOxSS register to follow the INTSR.INT bit. If system software is written to poll rather than receive interrupt requests, then software can read the INTSR.INT bit first to determine if any interrupt requests are active in the device.

Many of the latched status bits in the device can be the source of an interrupt request if their corresponding interrupt enable bits are set. The device's interrupt logic is shown in Figure 14. See the register map (Table 4) and the status register descriptions in section 6.3.2 for descriptions of the register bits shown in the figure.

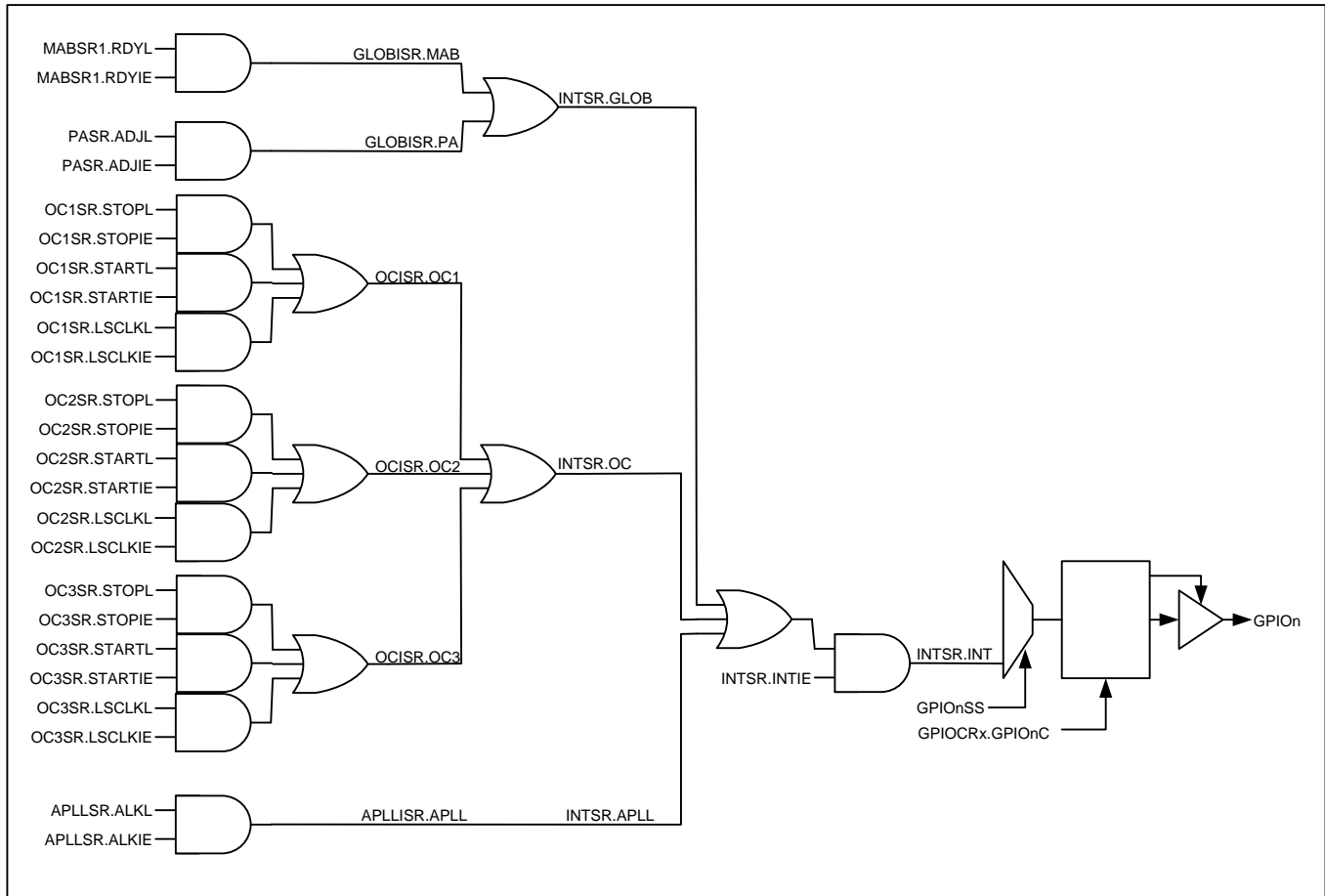

Figure 14 – Interrupt Structure

## 5.10 Reset Logic

The device has two reset controls: the RSTN pin and the RST bit in [MCR1](#). The RSTN pin asynchronously resets the entire device. When the RSTN pin is low all internal registers are reset to their default values. **The RSTN pin must have one rising edge after power-up.** At initial power-up reset should be asserted for at least 1 $\mu$ s. During operation, the RSTN assertion time can be as short as 1 $\mu$ s with one important exception:

Consider each of these four pins: AC0/GPIO0, AC1/GPIO1, TEST/GPIO2 and IF1/MISO. If (1) the pin could be an output driving high when RSTN is asserted, and (2) an external pulldown resistor is used to set the at-reset value of the pin, then RSTN should be asserted for 100 milliseconds.

The [MCR1.RST](#) bit resets the entire device (except for the microprocessor interface and the RST bit itself), but when the RST bit is active, the register fields with pin-programmed defaults do not latch their values from, or based on, the corresponding input pins. Instead these fields are reset to the default values that were latched when the RSTN pin was last active.

Microsemi recommends holding RSTN low while the internal ring oscillator starts up and stabilizes. An incorrect reset condition could result if RSTN is released before the oscillator has started up completely. After the external oscillator or internal crystal driver circuit has been enabled and stabilized, the master clock can be switched from the ring oscillator to the external oscillator using the [MCR1.MCSEL](#) bit.

**Important:** System software must wait at least 100 $\mu$ s after RSTN is deasserted and wait for [GLOBISR.BCDONE=1](#) before configuring the device.

## 5.11 Power-Supply Considerations

Due to the multi-power-supply nature of the device, some I/Os have parasitic diodes between a <3.3V supply and a 3.3V supply. When ramping power supplies up or down, care must be taken to avoid forward-biasing these diodes because it could cause latchup. Two methods are available to prevent this. The first method is to place a Schottky diode external to the device between the <3.3V supply and the 3.3V supply to force the 3.3V supply to be within one parasitic diode drop of the <3.3V supply. The second method is to ramp up the 3.3V supply first and then ramp up the <3.3V supply. In some applications VDDOx power supply pins can be at other voltages, such as 2.5V or 1.5V. In these applications the general solution is to ramp up the supplies in order from highest nominal to lowest nominal voltage.

## 5.12 Auto-Configuration from EEPROM

For the ZL30250, for applications where the device can operate stand-alone without supervision from a processor, the device can configure itself at reset from an external EEPROM connected to its SPI interface. The EEPROM can store up to three configurations, known as configurations 1, 2 and 3. As described in section [5.2.1](#), IF[1:0] must be 11 at reset, and the device configuration to be used is specified by the values of the AC[1:0] pins at reset (1, 2 or 3).

For the ZL30251, the internal EEPROM memory can store up to four device configurations, known as configurations 0, 1, 2 and 3. As described in section [5.2.2](#), the device configuration to be used is specified by the values of the AC[1:0] pins at reset.

### 5.12.1 Generating Device Configurations

Device configurations must be generated using the evaluation software. This is true for auto-configurations stored in internal or external EEPROM and for configurations that are written to the device by a system processor. The reason for this requirement is that writes to undocumented registers must be done to tune analog circuitry for optimal performance. The writes to be done depend on integer vs. fractional multiplication, device mode and other factors. The registers involved control very low-level device parameters that are difficult to describe and difficult to understand how to use. Instead the evaluation software has all of the expert knowledge built-in to keep configuration easy for the user.

### 5.12.2 Direct EEPROM Write Mode (ZL30251 Only)

To simplify writing the ZL30251's internal EEPROM during manufacturing, the device has a test mode known as direct EEPROM write mode. The device enters this mode when TEST=1 and AC[1:0]=00 on the rising edge of RSTN. In this mode the EEPROM memory is mapped into the address map and can be written as needed to store configuration scripts in the device. Device registers are not accessible in this mode. The device exits this mode when TEST=0 on the rising edge of RSTN. Note: the device drives the MISO pin continually during this mode. Therefore this mode cannot be used when MOSI and MISO are tied together (as described in the *Design Option: Wiring MOSI and MISO Together* paragraph in section 5.8.1).

### 5.12.3 Holding Other Devices in Reset During Auto-Configuration

Using the appropriate GPIOCR and GPIO0SS registers, a GPIO pin can be configured to follow the GLOBISR.BCDONE status bit. This GPIO can then be used as a reset signal to hold other devices (that use clocks from this device) in reset while the device configures itself. As an example, to configure GPIO0 to follow BCDONE with 0=reset add the following writes at the beginning of the configuration file: write 0x1F to GPIO0SS and write 0x04 to GPIOCR1.

## 5.13 Power Supply Decoupling and Layout Recommendations

Application Note ZLAN-490 describes recommended power supply decoupling and layout practices.

## 6. Register Descriptions

The device has an overall address range from 000h to 6FFh. Table 4 shows the register map. In each register, bit 7 is the MSb and bit 0 is the LSb. Register addresses not listed and bits marked “—” are reserved and must be written with 0. Writing other values to these registers may put the device in a factory test mode resulting in undefined operation. Bits labeled “0” or “1” must be written with that value for proper operation. Register fields with underlined names are read-only fields; writes to these fields have no effect. All other fields are read-write. Register fields are described in detail in the register descriptions that follow Table 4.

### 6.1 Register Types

#### 6.1.1 Status Bits

The device has two types of status bits. Real-time status bits are read-only and indicate the state of a signal at the time it is read. Latched status bits are set when a signal changes state (low-to-high, high-to-low, or both, depending on the bit) and cleared when written with a logic 1 value. Writing a 0 has no effect. When set, some latched status bits can cause an interrupt request if enabled to do so by corresponding interrupt enable bits. Status bits marked “—” are reserved and must be ignored.

#### 6.1.2 Configuration Fields

Configuration fields are read-write. During reset, each configuration field reverts to the default value shown in the register definition. Configuration register bits marked “—” are reserved and must be written with 0.

#### 6.1.3 Multiregister Fields

Multiregister fields—such as FREQZ[39:0] in registers DFREQZ1 through DFREQZ5—must be handled carefully to ensure that the bytes of the field remain consistent. A write access to a multiregister field is accomplished by writing all the registers of the field in order from smallest address to largest. Writes to registers other than the last register in the field (i.e. the register with the largest address) are stored in a transfer register. When the last register of the field is written, the entire multiregister field is updated simultaneously from the transfer register. If the last register of the field is not written, the field is not updated. Any reads from the multiregister field that occur during the middle of the multiregister write will read the existing value of the field not the new value in the transfer register.

A read access from a multiregister field is accomplished by reading the registers of the field in order from smallest address to largest. When the first register in the field (i.e. the register with the lowest address) is read, the entire multiregister field is copied to the transfer register. During subsequent reads from the other registers in the multiregister field, the data comes from the transfer register. Any writes to the multiregister field that occur during the middle of the multiregister read will overwrite values in the transfer register.

The device has one write transfer register and one read transfer register that it reuses for all multiregister fields. For proper operation system software should be organized such that only one software process accesses the device's registers. If two or more processes are allowed to make uncoordinated accesses to the device's registers, their accesses to multiregister fields could interrupt one another leading to incorrect writes and reads of the multiregister fields.

The multiregister fields are:

Field	Registers	Type
FREQZ[39:0]	DFREQZ1 to DFREQZ5	Read/Write

#### 6.1.4 Bank-Switched Registers (ZL30251 Only)

The **EESEL** register is a bank-select control field that maps the device registers into the memory map at address 0x1 and above when EESEL=0 and maps the EEPROM memory into the memory map at address 0x1 and above when EESEL=1. The EESEL register itself is always in the memory map at address 0x0 for both EESEL=0 and EESEL=1.

## 6.2 Register Map

Table 4 - Register Map

ADDR	REGISTER	BIT 7	BIT 6	BIT 5	BIT 4	BIT 3	BIT 2	BIT 1	BIT 0
<b>Global Configuration Registers</b>									
00h	EESEL	—	—	—	—	—	—	—	EESEL
09	MCR1	RST	—	MCSEL1	MCSEL	ROSCD	DBL	XAB[1:0]	
0A	MCR2	—	EXTSS[1:0]		—	—	—	—	—
0B	PLLEN	—	—	—	NCSSSEN	—	—	—	APLLEN
0C	ICEN	—	—	—	—	—	IC3EN	IC2EN	IC1EN
0D	OCEN	—	—	—	—	—	OC3EN	OC2EN	OC1EN
0E	GPIOCR1	GPIO1C[3:0]				GPIO0C[3:0]			
0F	GPIOCR2	GPIO3C[3:0]				GPIO2C[3:0]			
12	GPIO0SS	REG[4:0]				BIT[2:0]			
13	GPIO1SS	REG[4:0]				BIT[2:0]			
14	GPIO2SS	REG[4:0]				BIT[2:0]			
15	GPIO3SS	REG[4:0]				BIT[2:0]			
1B	PACR1	RST	TRIG	ARM	—	—	—	TINV	MODE
1C	PACR2	ARMSRC[3:0]				TRGSRC[3:0]			
1D	MABCR1	RST	START	—	—	—	TBSRC[2:0]		
1E	MABCR2	AINV	—	—	ASRC[4:0]				
1F	MABCR3	BINV	—	—	BSRC[4:0]				
<b>Status Registers</b>									
30	ID1	IDU[7:0]							
31	ID2	IDL[3:0]				REV[3:0]			
40	CFGSR	TEST	XOFAIL	—	—	IF[1:0]		AC[1:0]	
41	GPIOSR	—	—	—	—	GPIO3	GPIO2	GPIO1	GPIO0

ADDR	REGISTER	BIT 7	BIT 6	BIT 5	BIT 4	BIT 3	BIT 2	BIT 1	BIT 0
42	INTSR	—	GLOB	OC	—	—	APLL	INTIE	INT
43	GLOBISR	BCDONE	—	—	—	—	—	PA	MAB
45	OCISR	—	—	—	—	—	OC3	OC2	OC1
46	APLLISR	—	—	—	—	—	—	—	APLL
48	APLLSR	—	ALK2IE	ALK2L	ALK2	—	ALKIE	ALKL	ALK
4B	MABSR1	—	OVFL	RDYIE	RDYL	BUSY	MEAS[10:8]		
4C	MABSR2	MEAS[7:0]							
4D	PASR	—	—	—	—	ADJIE	ADJL	BUSY	ARMED
53	OC1SR	LSCLKIE	LSCLKL	LSCLK	STARTIE	STARTL	STOPIE	STOPL	STOPD
54	OC2SR	LSCLKIE	LSCLKL	LSCLK	STARTIE	STARTL	STOPIE	STOPL	STOPD
55	OC3SR	LSCLKIE	LSCLKL	LSCLK	STARTIE	STARTL	STOPIE	STOPL	STOPD
<b>APLL Configuration Registers</b>									
100	APLLCR1	—	—	—	—	—	ENHS2	BYPHS2	—
101	APLLCR2	HSDIV2[3:0]				HSDIV1[3:0]			
102	APLLCR3	—	EXTSW	ALTMUX[2:0]			APLLMUX[2:0]		
103	APLLCR4	DECPH	PDSS[2:0]			INCPH	PISS[2:0]		
106	AFBDIV1	AFBDIV[7:0]							
107	AFBDIV2	AFBDIV[15:8]							
108	AFBDIV3	AFBDIV[23:16]							
109	AFBDIV4	AFBDIV[31:24]							
10A	AFBDIV5	AFBDIV[39:32]							
10B	AFBDIV6	—	—	—	—	—	—	AFBDIV[41:40]	
10C	AFBDEN1	AFBDEN[7:0]							
10D	AFBDEN2	AFBDEN[15:8]							
10E	AFBDEN3	AFBDEN[23:16]							
10F	AFBDEN4	AFBDEN[31:24]							
110	AFBREM1	AFBREM[7:0]							
111	AFBREM2	AFBREM[15:8]							
112	AFBREM3	AFBREM[23:16]							
113	AFBREM4	AFBREM[31:24]							
114	AFBBP	AFBBP[7:0]							
<b>Output Clock Configuration Registers</b>									
<b>OC1 Registers</b>									
200	OC1CR1	PHEN	MSDIV[6:0]						
201	OC1CR2	—	POL	DRIVE[1:0]		STOPDIS	OCSF[2:0]		
202	OC1CR3	SRLSEN	DIVSEL	NEGLSD	LSSEL	—	—	—	LSDIV[24]
203	OC1DIV1	LSDIV[7:0]							
204	OC1DIV2	LSDIV[15:8]							
205	OC1DIV3	LSDIV[23:16]							
206	OC1DC	OCDC[7:0]							
207	OC1PH	PHADJ[7:0]							
208	OC1STOP	STOP	—	SRC[3:0]			MODE[1:0]		
<b>OC2 Registers</b>									
210	OC2CR1	same as OC1 registers							
...	...								
218	OC2STOP								
<b>OC3 Registers</b>									

ADDR	REGISTER	BIT 7	BIT 6	BIT 5	BIT 4	BIT 3	BIT 2	BIT 1	BIT 0
220	OC3CR1	same as OC1 registers							
...	...								
228	OC3STOP								
<b>Input Clock Configuration</b>									
300	IC1CR1	—	POL	—	—	—	—	HSDIV[1:0]	
320	IC2CR1	—	POL	—	—	—	—	HSDIV[1:0]	
340	IC3CR1	—	POL	—	—	—	—	HSDIV[1:0]	
<b>NCO/SS Configuration Registers</b>									
40B	NCSSCR1	—	—	—	—	MODE[3:0]			
420	DFREQZ1	FREQZ[7:0]							
421	DFREQZ2	FREQZ[15:8]							
422	DFREQZ3	FREQZ[23:16]							
423	DFREQZ4	FREQZ[31:24]							
424	DFREQZ5	FREQZ[39:32]							

## 6.3 Register Definitions

### 6.3.1 Global Configuration Registers

**Register Name:** EESEL  
**Register Description:** EEPROM Memory Selection Register  
**Register Address:** 00h

	Bit 7	Bit 6	Bit 5	Bit 4	Bit 3	Bit 2	Bit 1	Bit 0
<b>Name</b>	—	—	—	—	—	—	—	EESEL
<b>Default</b>	0	0	0	0	0	0	0	0

**Bit 0: EEPROM Memory Select (EESEL).** This bit is a bank-select that specifies whether device register space or EEPROM memory is mapped into addresses 0x1 and above. This applies only to the ZL30251. The ZL30250 does not have internal EEPROM memory. See sections 5.8 and 6.1.4. Note that this bit is write-only; the value read is not reliable.

0 = Device registers  
 1 = EEPROM memory

**Register Name:** MCR1  
**Register Description:** Master Configuration Register 1  
**Register Address:** 09h

	Bit 7	Bit 6	Bit 5	Bit 4	Bit 3	Bit 2	Bit 1	Bit 0
<b>Name</b>	RST	—	MCSEL1	MCSEL	ROSCD	DBL	XAB[1:0]	
<b>Default</b>	0	0	0	0	0	0	0	0

**Bit 7: Device Reset (RST).** When this bit is high the entire device is held in reset, and all register fields, except the RST bit itself, are reset to their default states. When RST is high, the register fields with pin-programmed defaults do not latch their values from the corresponding input pins. Instead these fields are reset to the default values that were latched from the pins when the RSTN pin was last active. See section 5.10.

0 = Normal operation  
 1 = Reset

Note: For proper sequencing of internal logic, write MCR1 to clear the MCSEL1, MCSEL and ROSCD bits first (without changing the value of the RST bit) then perform a second write to set the RST bit.  
 (Note: on rev A devices (ID2.REV=0) do not set this bit to 1.)

**Bit 5: NCO/SS Master Clock Select IC1 (MCSEL1).** This bit overrides the MCSEL bit to specify IC1 as the source of the NCO/SS block's master clock.

0 = Master clock selected by MCSEL bit

1 = Master clock sourced from IC1, which has a divider and a polarity control bit

**Bit 4: NCO/SS Master Clock Select (MCSEL).** This bit selects the source of the NCO/SS block's master clock. At reset the internal ring oscillator is enabled and selected. When operating the device in NCO mode or spread spectrum mode, this bit must be set to 1 after the external oscillator connected to the XA pin has stabilized and is ready to use. See section 5.3.4.

0 = Master clock sourced from internal ring oscillator

1 = Master clock sourced from the XA pin (optionally through the clock doubler)

**Bit 3: Ring Oscillator Disable (ROSCD).** This bit disables the ring oscillator. It can be set to 1 when either MCSEL or MCSEL1 is set 1 so that the ring oscillator does not cause unwanted phase noise spurs in output clock signals. See section 5.3.4.

0 = Enable

1 = Disable (power-down)

**Bit 2: Clock Doubler Enable (DBL).** This bit enables the clock doubler for either the output of the crystal driver circuitry or the signal on the XA pin. During power-up, system software must wait at least 5ms for the crystal driver circuit to stabilize before enabling the clock doubler. See section 5.3.3.

0 = Disable (power down)

1 = Enable

**Bits 1 to 0: XA/XB Pin Mode (XAB[1:0]).** This field specifies the behavior of the XA and XB pins. See section 5.3.

00 = Crystal driver and input disabled / powered down

01 = Crystal driver and input enabled on XA/XB

10 = XA enabled as single-ended input for external oscillator signal; XB must be left floating

11 = {unused value}

**Register Name:** MCR2  
**Register Description:** Master Configuration Register 2  
**Register Address:** 0Ah

	Bit 7	Bit 6	Bit 5	Bit 4	Bit 3	Bit 2	Bit 1	Bit 0
<b>Name</b>	—	EXTSS[1:0]		—	—	—	—	—
<b>Default</b>	0	0	0	0	0	0	0	0

**Bits 6 to 5: External Switch Source Select (EXTSS[1:0]).** This field selects the GPIO source for the external switch control signal. It is only valid when `APLLCR3.EXTSW=1`. See section 5.6.1.

00 = GPIO0

01 = GPIO1

10 = GPIO2

11 = GPIO3

**Register Name:** PLEN  
**Register Description:** APLL Enable Register  
**Register Address:** 0Bh

	Bit 7	Bit 6	Bit 5	Bit 4	Bit 3	Bit 2	Bit 1	Bit 0
<b>Name</b>	—	—	—	NCSSEN	—	—	—	APLLEN
<b>Default</b>	0	0	0	0	0	0	0	0

**Bit 4: NCO/SS Block Enable (NCSSEN).** This field enables or disables the NCO/SS block. See section 5.5. Note that the XA clock source must be properly configured and selected to operate the NCO/SS block.

0 = Disable (powered down)  
 1 = Enable

**Bit 0: APLL Enable (APLLEN).** This bit enables or disables the APLL. For normal operation the APLL must be enabled. See section 5.6.2.

0 = Disabled  
 1 = Enabled

**Register Name:** ICEN  
**Register Description:** Input Clock Enable Register  
**Register Address:** 0Ch

	Bit 7	Bit 6	Bit 5	Bit 4	Bit 3	Bit 2	Bit 1	Bit 0
<b>Name</b>	—	—	—	—	—	IC3EN	IC2EN	IC1EN
<b>Default</b>	0	0	0	0	0	0	0	0

**Bit 2: Input Clock 3 Enable (IC3EN).** This bit enables and disables the input clock 3 differential receiver and input dividers. See section 5.4.

0 = Disabled  
 1 = Enabled

**Bit 1: Input Clock 2 Enable (IC2EN).** This bit enables and disables the input clock 2 differential receiver and input dividers. See section 5.4.

0 = Disabled  
 1 = Enabled

**Bit 0: Input Clock 1 Enable (IC1EN).** This bit enables and disables the input clock 1 differential receiver and input dividers. See section 5.4.

0 = Disabled  
 1 = Enabled

**Register Name:** OCEN  
**Register Description:** Output Clock Enable Register  
**Register Address:** 0Dh

	Bit 7	Bit 6	Bit 5	Bit 4	Bit 3	Bit 2	Bit 1	Bit 0
<b>Name</b>	—	—	—	—	—	OC3EN	OC2EN	OC1EN
<b>Default</b>	0	0	0	0	0	0	0	0

**Bit 2: Output Clock 3 Enable (OC3EN).** This bit enables and disables the output clock 3 drivers, output dividers, phase adjustment/alignment circuitry and start/stop circuitry. See section 5.7.1.

0 = Disabled  
 1 = Enabled

**Bit 1: Output Clock 2 Enable (OC2EN).** This bit enables and disables the output clock 2 drivers, output dividers, phase adjustment/alignment circuitry and start/stop circuitry. See section 5.7.1.

0 = Disabled  
1 = Enabled

**Bit 0: Output Clock 1 Enable (OC1EN).** This bit enables and disables the output clock 1 drivers, output dividers, phase adjustment/alignment circuitry and start/stop circuitry. See section 5.7.1.

0 = Disabled  
1 = Enabled

**Register Name:** GPIOCR1  
**Register Description:** GPIO Configuration Register 1  
**Register Address:** 0Eh

	Bit 7	Bit 6	Bit 5	Bit 4	Bit 3	Bit 2	Bit 1	Bit 0
Name	GPIO1C[3:0]				GPIO0C[3:0]			
Default	0	0	0	0	0	0	0	0

**Bits 7 to 4: GPIO1 Configuration (GPIO1C[3:0]).** This field configures the GPIO1 pin as a general-purpose input, a general-purpose output driving low or high, or a status output. The current state of the pin can be read from [GPIOSR.GPIO1](#). When GPIO1 is a status output, the [GPIO1SS](#) register specifies which status bit is output.

0000 = General-purpose input  
0001 = General-purpose input - inverted polarity  
0010 = General-purpose output driving low  
0011 = General-purpose output driving high  
0100 = Status output – non-inverted polarity  
0101 = Status output - inverted polarity of the status bit it follows  
0110 = Status output – 0 drives low, 1 high impedance  
0111 = Status output – 0 high impedance, 1 drives low  
1000 to 1111 = {unused values}

**Bits 3 to 0: GPIO0 Configuration (GPIO0C[3:0]).** This field configures the GPIO0 pin as a general-purpose input, a general-purpose output driving low or high, or a status output. The current state of the pin can be read from [GPIOSR.GPIO0](#). When GPIO0 is a status output, the [GPIO0SS](#) register specifies which status bit is output.

0000 = General-purpose input  
0001 = General-purpose input - inverted polarity  
0010 = General-purpose output driving low  
0011 = General-purpose output driving high  
0100 = Status output – non-inverted polarity  
0101 = Status output - inverted polarity of the status bit it follows  
0110 = Status output – 0 drives low, 1 high impedance  
0111 = Status output – 0 high impedance, 1 drives low  
1000 to 1111 = {unused values}

**Register Name:** GPIOCR2  
**Register Description:** GPIO Configuration Register 2  
**Register Address:** 0Fh

	Bit 7	Bit 6	Bit 5	Bit 4	Bit 3	Bit 2	Bit 1	Bit 0
Name	GPIO3C[3:0]				GPIO2C[3:0]			
Default	0	0	0	0	0	0	0	0

These fields are identical to those in [GPIOCR1](#) except they control GPIO2 and GPIO3.

**Register Name:** GPIO0SS  
**Register Description:** GPIO0 Status Select Register  
**Register Address:** 12h

	Bit 7	Bit 6	Bit 5	Bit 4	Bit 3	Bit 2	Bit 1	Bit 0
Name	REG[4:0]					BIT[2:0]		
Default	0	0	0	0	0	0	0	0

**Bits 7 to 3: Status Register (REG[4:0]).** When [GPIOCR1.GPIO0C=01xx](#), this field specifies the register of the status bit that GPIO0 will follow while the BIT field below specifies the status bit within the register. Setting the combination of this field and the BIT field below to point to a bit that isn't implemented as a real-time or latched status register bit results in GPIO0 being driven low. The address of the status bit that GPIO0 follows is 0x40 + REG[4:0]

**Bits 2 to 0: Status Bit (BIT[2:0]).** When [GPIOCR1.GPIO0C=01xx](#), the REG field above specifies the register of the status bit that GPIO0 will follow while this field specifies the status bit within the register. Setting the combination of the REG field and this field to point to a bit that isn't implemented as a real-time or latched status register bit results in GPIO1 being driven low. 000=bit 0 of the register. 111=bit 7 of the register.

Note: The device does not allow the GPIO status register bits in [GPIOSR](#) to be followed by a GPIO.

**Register Name:** GPIO1SS  
**Register Description:** GPIO1 Status Select Register  
**Register Address:** 13h

	Bit 7	Bit 6	Bit 5	Bit 4	Bit 3	Bit 2	Bit 1	Bit 0
Name	REG[4:0]					BIT[2:0]		
Default	0	0	0	0	0	0	0	0

These fields are identical to those in [GPIO0SS](#) except they control GPIO1.

**Register Name:** GPIO2SS  
**Register Description:** GPIO2 Status Select Register  
**Register Address:** 14h

	Bit 7	Bit 6	Bit 5	Bit 4	Bit 3	Bit 2	Bit 1	Bit 0
Name	REG[4:0]					BIT[2:0]		
Default	0	0	0	0	0	0	0	0

These fields are identical to those in [GPIO0SS](#) except they control GPIO2.

**Register Name:** GPIO3SS  
**Register Description:** GPIO3 Status Select Register  
**Register Address:** 15h

	Bit 7	Bit 6	Bit 5	Bit 4	Bit 3	Bit 2	Bit 1	Bit 0
Name	REG[4:0]					BIT[2:0]		
Default	0	0	0	0	0	0	0	0

These fields are identical to those in [GPIO0SS](#) except they control GPIO3.

**Register Name:** PACR1  
**Register Description:** Phase Adjust Configuration Register 1  
**Register Address:** 1Bh

	Bit 7	Bit 6	Bit 5	Bit 4	Bit 3	Bit 2	Bit 1	Bit 0
<b>Name</b>	RST	TRIG	ARM	—	—	—	TINV	MODE
<b>Default</b>	0	0	0	0	0	0	0	0

**Bit 7: Phase Adjustment Reset Bit (RST).** This bit is used to reset the phase adjustment state machine. This is used to abort the phase adjustment after arming but before the trigger occurs. Resetting puts the state machine back to waiting for an arm signal. This bit is self-clearing. See section 5.7.4.

1 = Reset a phase adjustment event in progress, self clearing

**Bit 6: Phase Adjustment Trigger Bit (TRIG).** This bit is used to trigger the phase adjustment event when PACR2.TRGSRC=0000 and the phase adjustment has been armed. This bit is self-clearing and must be written again to cause another trigger. When the ARM bit and TRIG bit are selected as the sources for arming and triggering, respectively, the ARM bit must be set first then the TRIG bit can be set in a subsequent register write to initiate a trigger event. See section 5.7.4.

1 = Trigger a phase adjustment, self clearing

Note: For (1) phase adjustment when any OCx output's MSDIV period is less than master clock period, or (2) phase alignment when device is in APLL-only mode and any OCx output has MSDIV period + 7 x HSDIV period < 15.38ns, this bit may or may not self-clear depending on exact device configuration and therefore must be cleared by system software for proper operation.

**Bit 5: Phase Adjustment Arm Bit (ARM).** When PACR2.ARMSRC=0001, setting this bit to 1 while PASR.ARMED=0 arms the phase adjustment. Writing a 0 to this bit has no effect. Changing the value of this bit from 0 to 1 while PASR.ARMED=1 has no effect. See section 5.7.4.

1 = Arm the phase adjustment, self clearing

**Bit 1: Phase Adjustment Trigger Invert (TINV).** This bit specifies the polarity of the trigger signal. See section 5.7.4.

0 = Trigger signal normal polarity

1 = Trigger signal inverted

**Bit 0: Phase Adjust/Alignment Mode (MODE).** This field sets the mode of the phase change. In output phase *alignment* mode, the device resets the MSDIV and LSDIV dividers for all participating outputs so that they are all aligned and then adjusts the phase of each participating output as specified in the OCxPH register. In output phase *adjustment* mode the device does not reset the MSDIV and LSDIV dividers and therefore causes each participating output to have the phase adjustment specified in the OCxPH register relative to that output's previous phase. See section 5.7.4.

0 = Phase alignment mode

1 = Phase adjustment mode

**Register Name:** PACR2  
**Register Description:** Phase Adjust Configuration Register 2  
**Register Address:** 1Ch

	Bit 7	Bit 6	Bit 5	Bit 4	Bit 3	Bit 2	Bit 1	Bit 0
<b>Name</b>	ARMSRC[3:0]				TRGSRC[3:0]			
<b>Default</b>	0	0	0	0	0	0	0	0

**Bits 7 to 4: Output Phase Adjustment Arm Source (ARMSRC[3:0]).** This field selects the source of the phase adjustment arming signal. See section 5.7.4.

- 0000 = Always armed (see Note)
- 0001 = PACR1.ARM bit (one-shot)
- 0010 = APLL transition from unlocked to locked
- 0011 to 0111 = {unused values}
- 1000 = GPIO0 transition (see note below)
- 1001 = GPIO1 transition
- 1010 = GPIO2 transition
- 1011 = GPIO3 transition
- 1100 to 1111 = {unused values}

Note: When using always armed, any change to the PACR1 or PACR2 registers or any change to the OCxCR1.PHEN bits must be followed by a reset of the phase adjustment state machine (set PACR1.RST=1).

**Bits 3 to 0: Output Phase Adjustment Trigger Source (TRGSRC[3:0]).** This field selects the source of the phase adjustment trigger signal. The phase adjustment must be armed or the trigger signal is ignored. The trigger source transition initiates the phase adjustment event. See section 5.7.4.

- 0000 = PACR1.TRIG bit
- 0001 = APLL transition from unlocked to locked
- 0010 to 0111 = {unused values}
- 1000 = GPIO0 transition (see note below)
- 1001 = GPIO1 transition
- 1010 = GPIO2 transition
- 1011 = GPIO3 transition
- 1100 to 1111 = {unused values}

**Note:** In both fields above the GPIO transitions are 0-to-1 when GPIOCR1.GPIOxC=0000 and 1-to-0 when GPIOCR1.GPIOxC=0001.

**Register Name:** MABCR1  
**Register Description:** Measure A-to-B Configuration Register 1  
**Register Address:** 1Dh

	Bit 7	Bit 6	Bit 5	Bit 4	Bit 3	Bit 2	Bit 1	Bit 0
<b>Name</b>	RST	START	—	—	—	TBSRC[2:0]		
<b>Default</b>	0	0	0	0	0	0	0	0

**Bit 7: Measurement Reset (RST).** This field stops the current A-to-B phase measurement. This bit is self clearing. See section 5.7.6.

1 = Stop measurement (self-clearing)

**Bit 6: Measurement Start (START).** This field starts a new A-to-B phase measurement. This bit is self clearing. See section 5.7.6.

1 = Start new measurement (self-clearing)

**Bits 2 to 0: Measurement Time Base Source (TBSRC[2:0]).** This field selects the source of the measurement time base. See section 5.7.6.

000 = {reserved value, do not use}

001 = Medium-speed divider 1 (MSDIV1) output clock

010 = Medium-speed divider 2 (MSDIV2) output clock

011 = Medium-speed divider 3 (MSDIV3) output clock

**Register Name:** MABCR2  
**Register Description:** Measure A-to-B Configuration Register 2  
**Register Address:** 1Eh

	Bit 7	Bit 6	Bit 5	Bit 4	Bit 3	Bit 2	Bit 1	Bit 0
<b>Name</b>	AINV	—	—	ASRC[4:0]				
<b>Default</b>	0	0	0	0	0	0	0	0

**Bit 7: Measurement Input A Invert (AINV).** This field inverts the signal of measurement input A. See section 5.7.6.

0 = Measure to and from rising edge of input A

1 = Measure to and from falling edge of input A

**Bits 4 to 0: Measurement Input A Source (ASRC[4:0]).** This field selects the source of measurement input A. See section 5.7.6.

00000=IC1

00001=IC2

00010=IC3

01000 = GPIO0

01001 = GPIO1

01010 = GPIO2

01011 = GPIO3

10000=OC1

10001=OC2

10010=OC3

**Register Name:** MABCR3  
**Register Description:** Measure A to B Configuration Register 3  
**Register Address:** 1Fh

	Bit 7	Bit 6	Bit 5	Bit 4	Bit 3	Bit 2	Bit 1	Bit 0
<b>Name</b>	BINV	—	—	BSRC[4:0]				
<b>Default</b>	0	0	0	0	0	0	0	0

**Bit 7: Measurement Input B Invert (BINV).** This field inverts the signal of measurement input B. See section 5.7.6.

- 0 = Measure to and from rising edge of input B
- 1 = Measure to and from falling edge of input B

**Bits 4 to 0: Measurement Input B Source (BSRC[4:0]).** This field selects the source of measurement input B. See section 5.7.6.

- 00000=IC1
- 00001=IC2
- 00010=IC3
- 01000 = GPIO0
- 01001 = GPIO1
- 01010 = GPIO2
- 01011 = GPIO3
- 10000=OC1
- 10001=OC2
- 10010=OC3

### 6.3.2 Status Registers

**Register Name:** ID1  
**Register Description:** Device Identification Register, MSB  
**Register Address:** 30h

	Bit 7	Bit 6	Bit 5	Bit 4	Bit 3	Bit 2	Bit 1	Bit 0
<b>Name</b>	IDU[7:0]							
<b>Default</b>	0	0	0	1	1	0	0	1

**Bits 7 to 0: Device ID Upper (IDU[7:0]).** This field is the upper eight bits of the device ID.

**Register Name:** ID2  
**Register Description:** Device Identification Register, LSB and Revision  
**Register Address:** 31h

	Bit 7	Bit 6	Bit 5	Bit 4	Bit 3	Bit 2	Bit 1	Bit 0
<b>Name</b>	IDL[3:0]				REV[3:0]			
<b>Default</b>	See below				0	0	0	1

**Bits 7 to 4: Device ID Lower (IDL[3:0]).** This field is the lower four bits of the device ID.

- ZL30250 = 0000
- ZL30251 = 0001

**Bits 3 to 0: Device Revision (REV[3:0]).** These bits are the device hardware revision starting at 0.

**Register Name:** CFGSR  
**Register Description:** Configuration Status Register  
**Register Address:** 40h

	Bit 7	Bit 6	Bit 5	Bit 4	Bit 3	Bit 2	Bit 1	Bit 0
<b>Name</b>	TEST	XOFAIL	—	—	IF[1:0]		AC[1:0]	
<b>Default</b>	see below	0	0	0	see below	see below	see below	see below

**Bit 7: Test Mode (TEST).** This read-only bit is the latched state of the TEST/GPIO2 pin when the RSTN pin transitions high. For proper operation it should be 0. See section 5.2.

**Bit 6: XO Fail (XOFAIL).** This read-only bit is set when the external oscillator signal on the XA pin fails or when the crystal connected to the XA/XB pins fails to oscillate.

**Bits 3 to 2: Interface Mode (IF[1:0]).** These read-only bits are the latched state of the IF1/MISO and IF0/CSN pins when the RSTN pin transitions high. See section 5.2.

**Bits 1 to 0: Auto-Configuration (AC[1:0]).** These read-only bits are the latched state of the AC1/GPIO1 and AC0/GPIO0 pins when the RSTN pin transitions high. See section 5.2.

**Register Name:** GPIOSR  
**Register Description:** GPIO Status Register  
**Register Address:** 41h

	Bit 7	Bit 6	Bit 5	Bit 4	Bit 3	Bit 2	Bit 1	Bit 0
<b>Name</b>	—	—	—	—	GPIO3	GPIO2	GPIO1	GPIO0
<b>Default</b>	0	0	0	0	0	0	0	0

**Bit 3: GPIO3 State (GPIO3).** This real-time status bit indicates the current state of the GPIO3 pin, not influenced by any inversion that may be specified by GPIOCR2.GPIO3C.

0 = low  
 1 = high

**Bit 2: GPIO2 State (GPIO2).** This real-time status bit indicates the current state of the GPIO2 pin, not influenced by inversion that may be specified by GPIOCR2.GPIO2C.

0 = low  
 1 = high

**Bit 1: GPIO1 State (GPIO1).** This real-time status bit indicates the current state of the GPIO1 pin, not influenced by inversion that may be specified by GPIOCR1.GPIO1C.

0 = low  
 1 = high

**Bit 0: GPIO0 State (GPIO0).** This real-time status bit indicates the current state of the GPIO0 pin, not influenced by inversion that may be specified by GPIOCR1.GPIO0C.

0 = low  
 1 = high

**Register Name:** INTSR  
**Register Description:** Interrupt Status Register  
**Register Address:** 42h

	Bit 7	Bit 6	Bit 5	Bit 4	Bit 3	Bit 2	Bit 1	Bit 0
<b>Name</b>	—	<u>GLOB</u>	<u>OC</u>	—	—	<u>APLL</u>	INTIE	<u>INT</u>
<b>Default</b>	0	0	0	0	0	0	0	0

**Bit 6: Global Interrupt Status (GLOB).** This read-only bit is set if any of the global interrupt status bits are set in the [GLOBISR](#) register. See section [5.9](#).

**Bit 5: Output Clock Interrupt Status (OC).** This read-only bit is set if any of the output clock interrupt status bits are set in the [OCISR](#) register. See section [5.9](#).

**Bit 2: APLL Interrupt Status (APLL).** This read-only bit is set if any of the APLL interrupt status bits are set in the [APLLISR](#) register. See section [5.9](#).

**Bit 1: Interrupt Enable Bit (INTIE).** This is the global interrupt enable bit. When this bit is 0 all interrupt sources are prevented from setting the INT global interrupt status bit (below). See section [5.9](#).

- 0 = Interrupts are disabled at the global level
- 1 = Interrupts are enabled at the global level

**Bit 0: Interrupt Status (INT).** This read-only bit is set when any of the GLOB, OC or APLL bits in this [INTSR](#) register are set and the INTIE bit is set. This bit can cause an interrupt request when set by configuring one of the GPIO pins to follow it. See section [5.9](#).

- 0 = No interrupt
- 1 = An unmasked interrupt source is active

**Register Name:** GLOBISR  
**Register Description:** Global Functions Interrupt Status Register  
**Register Address:** 43h

	Bit 7	Bit 6	Bit 5	Bit 4	Bit 3	Bit 2	Bit 1	Bit 0
<b>Name</b>	<u>BCDONE</u>	—	—	—	—	—	<u>PA</u>	<u>MAB</u>
<b>Default</b>	see below	0	0	0	0	0	0	0

**Bit 7: Boot Controller Done (BCDONE).** This bit indicates the status of the on-chip boot controller, which performs auto-configuration from EEPROM. It is cleared when the device is reset and set after the boot controller finishes auto-configuration of the device. See section [5.12](#).

**Bit 1: Phase Adjust Interrupt Status (PA).** This bit indicates the current status of the interrupt sources from the phase adjust function (see section [5.7.4](#)). It is set when any latched status bit in the [PASR](#) register is set and the associated interrupt enable bit is also set. See section [5.9](#).

**Bit 0: Measure AB Interrupt Status (MAB).** This bit indicates the current status of the interrupt sources from the A-to-B phase offset measurement function (see section [5.7.6](#)). It is set when any latched status bit in the [MABSR1](#) register is set and the associated interrupt enable bit is also set. See section [5.9](#).

**Register Name:** OCISR  
**Register Description:** Output Clock Interrupt Status Register  
**Register Address:** 45h

	Bit 7	Bit 6	Bit 5	Bit 4	Bit 3	Bit 2	Bit 1	Bit 0
<b>Name</b>	—	—	—	—	—	<u>OC3</u>	<u>OC2</u>	<u>OC1</u>
<b>Default</b>	0	0	0	0	0	0	0	0

**Bit 2: Output Clock 3 Interrupt Status (OC3).** This bit indicates the current status of the interrupt sources for OC3. It is set when any latched status bit in the [OC3SR](#) register is set and the associated interrupt enable bit is also set. See section [5.9](#).

**Bit 1: Output Clock 2 Interrupt Status (OC2).** This bit indicates the current status of the interrupt sources for OC2. It is set when any latched status bit in the [OC2SR](#) register is set and the associated interrupt enable bit is also set. See section [5.9](#).

**Bit 0: Output Clock 1 Interrupt Status (OC1).** This bit indicates the current status of the interrupt sources for OC1. It is set when any latched status bit in the [OC1SR](#) register is set and the associated interrupt enable bit is also set. See section [5.9](#).

**Register Name:** APLLISR  
**Register Description:** APLL Interrupt Status Register  
**Register Address:** 46h

	Bit 7	Bit 6	Bit 5	Bit 4	Bit 3	Bit 2	Bit 1	Bit 0
<b>Name</b>	—	—	—	—	—	—	—	<u>APLL</u>
<b>Default</b>	0	0	0	0	0	0	0	0

**Bit 0: APLL Interrupt Status (APLL).** This bit indicates the current status of the interrupt sources for the APLL. It is set when any latched status bit in the [APLLSR](#) register is set and the associated interrupt enable bit is also set. See section [5.9](#).

**Register Name:** APLLSR  
**Register Description:** APLL Status Register  
**Register Address:** 48h

	Bit 7	Bit 6	Bit 5	Bit 4	Bit 3	Bit 2	Bit 1	Bit 0
<b>Name</b>	—	ALK2IE	ALK2L	ALK2	—	ALKIE	ALKL	ALK
<b>Default</b>	0	0	0	0	0	0	0	0

**Bit 6: APLL Lock 2 Interrupt Enable (ALK2IE).** This bit enables the ALK2L latched status bit to send an interrupt request into device's interrupt logic.

- 0 = Interrupt is disabled
- 1 = Interrupt is enabled

**Bit 5: APLL Lock 2 Latched Status (ALK2L).** This latched status bit is set to 1 when the ALK2 status bit changes state (set or cleared). ALK2L is cleared when written with a 1. When ALK2L is set it can cause an interrupt request if the ALK2IE interrupt enable bit is set.

**Bit 4: APLL Lock Status 2 (ALK2).** This real-time status bit provides one type of APLL lock status. System software should consider the APLL locked when ALK (bit 0) is set to 1 AND ALK2=1. See section 5.6.

**Bit 2: APLL Lock Interrupt Enable (ALKIE).** This bit enables the ALKL latched status bit to send an interrupt request into device's interrupt logic.

- 0 = Interrupt is disabled
- 1 = Interrupt is enabled

**Bit 1: APLL Lock Latched Status (ALKL).** This latched status bit is set to 1 when the ALK status bit changes state (set or cleared). ALKL is cleared when written with a 1. When ALKL is set it can cause an interrupt request if the ALKIE interrupt enable bit is set.

**Bit 0: APLL Lock Status (ALK).** This real-time status bit indicates one type of APLL lock status. System software should consider the APLL locked when ALK=1 AND ALK2 (bit 4) is set to 1. See section 5.6.

- 0 = Not locked
- 1 = Locked

**Register Name:** MABSR1  
**Register Description:** Measure A to B Status Register 1  
**Register Address:** 4Bh

	Bit 7	Bit 6	Bit 5	Bit 4	Bit 3	Bit 2	Bit 1	Bit 0
<b>Name</b>	—	OVFL	RDYIE	RDYL	BUSY	MEAS[10:8]		
<b>Default</b>	0	0	0	0	0	0	0	0

**Bit 6: Measurement Overflow (OVFL).** This latched status bit is set when the phase measurement is ready and an overflow has occurred. See section 5.7.6.

- 0 = No measurement overflow, MEAS is a valid value
- 1 = A measurement overflow occurred, MEAS is not a valid value

**Bit 5: Measurement Ready Interrupt Enable (RDYIE).** This bit enables the RDYL latched status bit to send an interrupt request into device's interrupt logic.

- 0 = Interrupt is disabled
- 1 = Interrupt is enabled

**Bit 4: Measurement Ready (RDYL).** This latched status bit is set when a new phase measurement is ready. See section 5.7.6.

- 0 = New measurement not ready
- 1 = A new measurement in MEAS is ready

**Bit 3: Measurement Busy (BUSY).** This real-time status bit is set when a new phase measurement is being performed. See section 5.7.6.

- 0 = A measurement is not being performed
- 1 = A measurement is being performed

**Bits 2 to 0: Measurement Value (MEAS[10:8]).** See the [MABSR2](#) register description.

**Register Name:** MABSR2  
**Register Description:** Measure A to B Status Register 2  
**Register Address:** 4Ch

	Bit 7	Bit 6	Bit 5	Bit 4	Bit 3	Bit 2	Bit 1	Bit 0
<b>Name</b>	MEAS[7:0]							
<b>Default</b>	0	0	0	0	0	0	0	0

**Bits 7 to 0: Measurement Value (MEAS[7:0]).** The full 11-bit MEAS[10:0] field spans this register and the lower bits of [MABSR1](#). The format is two's-complement. This field indicates the result of the A-to-B measurement when BUSY=0, RDYL=1 and OVFL=0. Its value is in units of the selected timebase period and has a range of +1023 to -1024 periods. See section 5.7.6.

**Register Name:** PASR  
**Register Description:** Phase Adjust Status Register  
**Register Address:** 4Dh

	Bit 7	Bit 6	Bit 5	Bit 4	Bit 3	Bit 2	Bit 1	Bit 0
<b>Name</b>	—	—	—	—	ADJIE	ADJL	BUSY	ARMED
<b>Default</b>	1	0	0	0	0	1	0	0

**Bit 3: Phase Adjustment Finished Interrupt Enable (ADJIE).** This bit enables the ADJL latched status bit to send an interrupt request into the device's interrupt logic.

- 0 = Interrupt is disabled
- 1 = Interrupt is enabled

**Bit 2: Phase Adjustment Finished (ADJL).** This latched status bit is set when the output phase adjustment is completed for all participating outputs. Writing a 1 to this bit clears it. See section 5.7.4.

- 0 = Output phase adjustment has not completed
- 1 = Output phase adjustment has completed

Note: For (1) phase adjustment when any OCx output's MSDIV period is less than master clock period, or (2) phase alignment when device is in APLL-only mode and any OCx output has MSDIV period + 7 x HSDIV period < 15.38ns, this bit may or may not be set depending on exact device configuration and therefore should not be checked by system software. Instead the state of the BUSY real-time bit (bit 1) should be checked.

**Bit 1: Phase Adjustment Busy (BUSY).** This bit is a real time status that indicates that the output phase adjustment has been triggered and is in progress on the participating outputs. See section 5.7.4.

- 0 = Output phase adjustment is not in progress
- 1 = Output phase adjustment is in progress

**Bit 0: Phase Adjustment Armed (ARMED).** This bit is a real time status that indicates that the output phase adjustment is armed and waiting for a trigger. It is cleared when the trigger event occurs. See section 5.7.4.

- 0 = Output phase adjustment is not armed
- 1 = Output phase adjustment is armed

**Register Name:** OCxSR  
**Register Description:** Output Clock x Status Register  
**Register Address:** OC1: 53h, OC2: 54h, OC3: 55h

	Bit 7	Bit 6	Bit 5	Bit 4	Bit 3	Bit 2	Bit 1	Bit 0
<b>Name</b>	LSCLKIE	LSCLKL	LSCLK	STARTIE	STARTL	STOPIE	STOPL	STOPD
<b>Default</b>	0	0	0	0	0	0	see note	see note

**Bit 7: (LSCLKIE).** This bit enables the LSCLKL latched status bit to send an interrupt request into device's interrupt logic.

- 0 = Interrupt is disabled
- 1 = Interrupt is enabled

**Bit 6: (LSCLKL).** This latched status bit is set when the low-speed divider output clock transitions low-to-high. Writing a 1 to this bit clears it.

- 0 = Low speed output clock has not transitioned low to high
- 1 = Low speed output clock has transitioned low to high

**Bit 5: (LSCLK).** This real-time status bit follows the level of the low-speed divider output clock when the [OCxCR3.SRLSEN](#) bit is set.

- 0 = LSCLK is high
- 1 = LSCLK is low

**Bit 4: (STARTIE).** This bit enables the STARTL latched status bit to send an interrupt request into device's interrupt logic.

- 0 = Interrupt is disabled
- 1 = Interrupt is enabled

**Bit 3: (STARTL).** This latched status bit is set when the output clock signal has been started after being stopped. Writing a 1 to this bit clears it. See section [5.7.5](#).

- 0 = Output clock signal has not resumed from being stopped
- 1 = Output clock signal has resumed from being stopped

**Bit 2: (STOPIE).** This bit enables the STOPL latched status bit to send an interrupt request into device's interrupt logic.

- 0 = Interrupt is disabled
- 1 = Interrupt is enabled

**Bit 1: (STOPL).** This latched status bit is set when the output clock signal has been stopped. Writing a 1 to this bit clears it. See section [5.7.5](#).

- 0 = Output clock signal has not stopped
- 1 = Output clock signal has stopped

**Bit 0: (STOPD).** This real-time status bit is high when the output clock signal is stopped and low when the output clock is not stopped. See section [5.7.5](#).

- 0 = Output clock signal is not stopped
- 1 = Output clock signal is stopped

**Note:** STOPL and STOPD are controlled by logic that does not have a clock at reset. Therefore their reset values are indeterminate. They will become 0 when the output clock path is configured and one of the high-speed clocks from the APLL is connected to the logic.

### 6.3.3 APLL Configuration Registers

**Register Name:** APLLCR1  
**Register Description:** APLL Configuration Register 1  
**Register Address:** 100h

	Bit 7	Bit 6	Bit 5	Bit 4	Bit 3	Bit 2	Bit 1	Bit 0
<b>Name</b>	—	—	—	—	—	ENHS2	BYPHS2	—
<b>Default</b>	0	0	0	0	0	0	0	0

**Bit 2: Enable High-Speed Divider 2 (ENHS2).** This bit is an enable/disable control for HSDIV2. When HSDIV2 is disabled, device power consumption is reduced as shown in [Table 6](#). HSDIV2 is enabled when `PLLEN.APLLEN=1`, `ENHS2=1` and `APLLCR1.BYPHS2=0`.

0 = Disable  
 1 = Enable

**Bit 1: Bypass APLL and High-Speed Divider 2 (BYPHS2).** This bit controls the mux immediately to the right of HSDIV2 in [Figure 1](#). The mux that provides the bypass signal to this mux is controlled by `APLLMUX` and related fields in `APLLCR3`.

0 = No bypass  
 1 = Bypass

**Register Name:** APLLCR2  
**Register Description:** APLL Configuration Register 2  
**Register Address:** 101h

	Bit 7	Bit 6	Bit 5	Bit 4	Bit 3	Bit 2	Bit 1	Bit 0
<b>Name</b>	HSDIV2[3:0]				HSDIV1[3:0]			
<b>Default</b>	0	0	0	0	0	0	0	0

**Bits 7 to 4: APLL High-Speed Divider 2 (HSDIV2[3:0]).** This field controls the APLL's high-speed divider 2 block (see [Figure 6](#)). See section [5.6.2](#).

0000 = Divide by 4	1000 = Divide by 8
0001 = Divide by 4.5	1001 = Divide by 9
0010 = Divide by 5	1010 = Divide by 10
0011 = Divide by 5.5	1011 = Divide by 11
0100 = Divide by 6	1100 = Divide by 12
0101 = Divide by 6.5	1101 = Divide by 13
0110 = Divide by 7	1110 = Divide by 14
0111 = Divide by 7.5	1111 = Divide by 15

**Bits 3 to 0: APLL High-Speed Divider 1 (HSDIV1[3:0]).** This field controls the APLL's high-speed divider 1 block (see [Figure 6](#)). See section [5.6.2](#).

0000 = Divide by 4	1000 = Divide by 8
0001 = Divide by 4.5	1001 = Divide by 9
0010 = Divide by 5	1010 = Divide by 10
0011 = Divide by 5.5	1011 = Divide by 11
0100 = Divide by 6	1100 = Divide by 12
0101 = Divide by 6.5	1101 = Divide by 13
0110 = Divide by 7	1110 = Divide by 14
0111 = Divide by 7.5	1111 = Divide by 15

**Register Name:** APLLCR3  
**Register Description:** APLL Configuration Register 3  
**Register Address:** 102h

	Bit 7	Bit 6	Bit 5	Bit 4	Bit 3	Bit 2	Bit 1	Bit 0
<b>Name</b>	—	EXTSW	ALTMUX[2:0]			APLLMUX[2:0]		
<b>Default</b>	0	0	0	0	0	0	0	0

**Bit 6: APLL External Switching Mode (EXTSW).** This bit enables APLL external reference switching mode. In this mode, if the selected GPIO signal is low the APLL input mux is controlled by [APLLCR3.APLLMUX](#). If the selected GPIO signal is high the APLL input mux is controlled by [APLLCR3.ALTMUX](#). [MCR2.EXTSS](#) specifies which GPIO pin controls this behavior. See section [5.6.1](#)

**Bits 5 to 3: APLL Alternate Mux Control (ALTMUX[2:0]).** When [APLLCR3.EXTSW](#)=0 this field is ignored. When [APLLCR3.EXTSW](#)=1 and the selected GPIO signal is high, this field controls the APLL input muxes. See section [5.6.1](#).

- 000 = Crystal driver circuit if crystal is connected, otherwise XA input  
(clock frequency can be 2x if clock doubler enabled by [MCR1.DBL](#)=1)
- 001 = IC1 input
- 010 = IC2 input
- 011 = IC3 input
- 100-111 = {unused values}

**Bits 2 to 0: APLL Mux Control (APLLMUX[2:0]).** By default this field controls the APLL input muxes. When [APLLCR3.EXTSW](#)=1 and the selected GPIO signal is high, this field is ignored, and the APLL's clock source is specified by [APLLCR3.ALTMUX](#). See section [5.6.1](#).

- 000 = Crystal driver circuit if crystal is connected, otherwise XA input  
(clock frequency can be 2x if clock doubler enabled by [MCR1.DBL](#)=1)
- 001 = IC1 input
- 010 = IC2 input
- 011 = IC3 input
- 110 = NCO/SS output to the APLL, XA (optionally doubled) sent to the bypass mux
- 111 = NCO/SS output to the APLL, no signal sent to the bypass mux (set [APLLCR1.BYPHS2](#)=0)

The following decodes are for applications where the NCO/SS master clock comes from IC1 rather than XA ([MCR1.MCSEL1](#)=1).

- 100 = NCO/SS output to the APLL, IC1 sent to the bypass mux
- 101 = NCO/SS output to the APLL, no signal sent to the bypass mux (set [APLLCR1.BYPHS2](#)=0)

**Register Name:** APLLCR4  
**Register Description:** APLL Configuration Register 4  
**Register Address:** 103h

	Bit 7	Bit 6	Bit 5	Bit 4	Bit 3	Bit 2	Bit 1	Bit 0
<b>Name</b>	DECPH	PDSS[2:0]			INCPH	PISS[2:0]		
<b>Default</b>	0	0	0	0	0	0	0	0

**Bit 7: Decrement Phase (DECPH).** When PDSS=000, this bit is the APLL phase decrement control signal. See section 5.6.3. Decrement moves the signal earlier in time (to the left on a scope).

**Bits 6 to 4: Phase Decrement Source Select (PDSS[2:0]).** This field specifies the APLL phase decrement control signal. Every low-to-high transition and every high-to-low transition of the signal decrements the APLL's output phase. See section 5.6.3.

- 000 = DECPH bit
- 001 = GPIO0
- 010 = GPIO1
- 011 = GPIO2
- 100 = GPIO3
- 101 to 111 = {unused values}

**Bit 3: Increment Phase (INCPH).** When PISS=000, this bit is the APLL phase increment control signal. See section 5.6.3. Increment moved the signal later in time (to the right on a scope).

**Bits 2 to 0: Phase Increment Source Select (PISS[2:0]).** This field specifies the APLL phase increment control signal. Every low-to-high transition and every high-to-low transition of the signal increments the APLL's output phase. See section 5.6.3.

- 000 = INCPH bit
- 001 = GPIO0
- 010 = GPIO1
- 011 = GPIO2
- 100 = GPIO3
- 101 to 111 = {unused values}

**Register Name:** AFBDIV1  
**Register Description:** APLL Feedback Divider Register 1  
**Register Address:** 106h

	Bit 7	Bit 6	Bit 5	Bit 4	Bit 3	Bit 2	Bit 1	Bit 0
<b>Name</b>	AFBDIV[7:0]							
<b>Default</b>	0	0	0	0	0	0	0	0

**Bits 7 to 0: APLL Feedback Divider Register (AFBDIV[7:0]).** The full 42-bit AFBDIV[41:0] field spans the AFBDIV1 through AFBDIV6 registers. AFBDIV is an unsigned number with 9 integer bits (AFBDIV[41:33]) and up to 33 fractional bits. AFBDIV specifies the fixed-point term of the APLL's fractional feedback divide value. The value AFBDIV=0 is undefined. Unused least significant bits must be written with 0. See section 5.6.2.

**Register Name:** AFBDIV2  
**Register Description:** APLL Feedback Divider Register 2  
**Register Address:** 107h

	Bit 7	Bit 6	Bit 5	Bit 4	Bit 3	Bit 2	Bit 1	Bit 0
Name	AFBDIV[15:8]							
Default	0	0	0	0	0	0	0	0

Bits 7 to 0: APLL Feedback Divider Register (AFBDIV[15:8]). See the [AFBDIV1](#) register description.

**Register Name:** AFBDIV3  
**Register Description:** APLL Feedback Divider Register 3  
**Register Address:** 108h

	Bit 7	Bit 6	Bit 5	Bit 4	Bit 3	Bit 2	Bit 1	Bit 0
Name	AFBDIV[23:16]							
Default	0	0	0	0	0	0	0	0

Bits 7 to 0: APLL Feedback Divider Register (AFBDIV[23:16]). See the [AFBDIV1](#) register description.

**Register Name:** AFBDIV4  
**Register Description:** APLL Feedback Divider Register 4  
**Register Address:** 109h

	Bit 7	Bit 6	Bit 5	Bit 4	Bit 3	Bit 2	Bit 1	Bit 0
Name	AFBDIV[31:24]							
Default	0	0	0	0	0	0	0	0

Bits 7 to 0: APLL Feedback Divider Register (AFBDIV[31:24]). See the [AFBDIV1](#) register description.

**Register Name:** AFBDIV5  
**Register Description:** APLL Feedback Divider Register 5  
**Register Address:** 10Ah

	Bit 7	Bit 6	Bit 5	Bit 4	Bit 3	Bit 2	Bit 1	Bit 0
Name	AFBDIV[39:32]							
Default	0	0	0	0	0	0	0	0

Bits 7 to 0: APLL Feedback Divider Register (AFBDIV[39:32]). See the [AFBDIV1](#) register description.

**Register Name:** AFBDIV6  
**Register Description:** APLL Feedback Divider Register 6  
**Register Address:** 10Bh

	Bit 7	Bit 6	Bit 5	Bit 4	Bit 3	Bit 2	Bit 1	Bit 0
Name	—	—	—	—	—	—	AFBDIV[41:40]	
Default	0	0	0	0	0	0	0	0

Bits 7 to 0: APLL Feedback Divider Register (AFBDIV[41:40]). See the [AFBDIV1](#) register description.

**Register Name:** AFBDEN1  
**Register Description:** APLL Feedback Divider Denominator Register 1  
**Register Address:** 10Ch

	Bit 7	Bit 6	Bit 5	Bit 4	Bit 3	Bit 2	Bit 1	Bit 0
<b>Name</b>	AFBDEN[7:0]							
<b>Default</b>	0	0	0	0	0	0	0	1

**Bits 7 to 0: APLL Feedback Divider Denominator Register (AFBDEN[7:0]).** The full 32-bit AFBDEN[31:0] field spans AFBDEN1 through AFBDEN4 registers. AFBDEN is an unsigned integer that specifies the denominator of the APLL's fractional feedback divide value. The value AFBDEN=0 is undefined. When [AFBBP=0](#), [AFBDEN](#) must be set to 1. See section [5.6.2](#).

**Register Name:** AFBDEN2  
**Register Description:** APLL Feedback Divider Denominator Register 2  
**Register Address:** 10Dh

	Bit 7	Bit 6	Bit 5	Bit 4	Bit 3	Bit 2	Bit 1	Bit 0
<b>Name</b>	AFBDEN[15:8]							
<b>Default</b>	0	0	0	0	0	0	0	0

**Bits 7 to 0: APLL Feedback Divider Denominator Register (AFBDEN[15:8]).** See the [AFBDEN1](#) register description.

**Register Name:** AFBDEN3  
**Register Description:** APLL Feedback Divider Denominator Register 3  
**Register Address:** 10Eh

	Bit 7	Bit 6	Bit 5	Bit 4	Bit 3	Bit 2	Bit 1	Bit 0
<b>Name</b>	AFBDEN[23:16]							
<b>Default</b>	0	0	0	0	0	0	0	0

**Bits 7 to 0: APLL Feedback Divider Denominator Register (AFBDEN[23:16]).** See the [AFBDEN1](#) register description.

**Register Name:** AFBDEN4  
**Register Description:** APLL Feedback Divider Denominator Register 4  
**Register Address:** 10Fh

	Bit 7	Bit 6	Bit 5	Bit 4	Bit 3	Bit 2	Bit 1	Bit 0
<b>Name</b>	AFBDEN[31:24]							
<b>Default</b>	0	0	0	0	0	0	0	0

**Bits 7 to 0: APLL Feedback Divider Denominator Register (AFBDEN[31:24]).** See the [AFBDEN1](#) register description.

**Register Name:** AFBREM1  
**Register Description:** APLL Feedback Divider Remainder Register 1  
**Register Address:** 110h

	Bit 7	Bit 6	Bit 5	Bit 4	Bit 3	Bit 2	Bit 1	Bit 0
<b>Name</b>	AFBREM[7:0]							
<b>Default</b>	0	0	0	0	0	0	0	0

**Bits 7 to 0: APLL Feedback Divider Remainder Register (AFBREM[7:0]).** The full 32-bit AFBDEN[31:0] field spans AFBREM1 through AFBREM4 registers. AFBREM is an unsigned integer that specifies the remainder of the APLL's fractional feedback divider value. When [AFBBP=0](#), [AFBREM](#) must be set to 0. See section [5.6.2](#).

**Register Name:** AFBREM2  
**Register Description:** APLL Feedback Divider Remainder Register 2  
**Register Address:** 111h

	Bit 7	Bit 6	Bit 5	Bit 4	Bit 3	Bit 2	Bit 1	Bit 0
<b>Name</b>	AFBREM[15:8]							
<b>Default</b>	0	0	0	0	0	0	0	0

**Bits 7 to 0: APLL Feedback Divider Remainder Register (AFBREM[15:8]).** See the [AFBREM1](#) register description.

**Register Name:** AFBREM3  
**Register Description:** APLL Feedback Divider Remainder Register 3  
**Register Address:** 112h

	Bit 7	Bit 6	Bit 5	Bit 4	Bit 3	Bit 2	Bit 1	Bit 0
<b>Name</b>	AFBREM[23:16]							
<b>Default</b>	0	0	0	0	0	0	0	0

**Bits 7 to 0: APLL Feedback Divider Remainder Register (AFBREM[23:16]).** See the [AFBREM1](#) register description.

**Register Name:** AFBREM4  
**Register Description:** APLL Feedback Divider Remainder Register 4  
**Register Address:** 113h

	Bit 7	Bit 6	Bit 5	Bit 4	Bit 3	Bit 2	Bit 1	Bit 0
<b>Name</b>	AFBREM[31:24]							
<b>Default</b>	0	0	0	0	0	0	0	0

**Bits 7 to 0: APLL Feedback Divider Remainder Register (AFBREM[31:24]).** See the [AFBREM1](#) register description.

**Register Name:** AFBBP  
**Register Description:** APLL Feedback Divider Truncate Bit Position  
**Register Address:** 114h

	Bit 7	Bit 6	Bit 5	Bit 4	Bit 3	Bit 2	Bit 1	Bit 0
<b>Name</b>	AFBBP[7:0]							
<b>Default</b>	0	0	0	0	0	0	0	0

**Bits 7 to 0: APLL Feedback Divider Truncate Bit Position (AFBBP[7:0]).** This unsigned integer specifies the number of fractional bits that are valid in the [AFBDIV](#) value. There are 33 fractional bits in AFBDIV. The value in this AFBBP field specifies 33 – number\_of\_valid\_AFBDIV\_fractional\_bits. When AFBBP=0 all 33 AFBDIV fractional bits are valid. When AFBBP=9, the most significant 24 AFBDIV fractional bits are valid and the least significant 9 bits must be set to 0. This register field is only used when the feedback divider value is expressed in the form  $AFBDIV + AFBREM / AFBDEN$ . AFBBP values greater than 33 are invalid. When AFBBP=0, [AFBREM](#) must be set to 0 and [AFBDEN](#) must be set to 1. See section [5.6.2](#).

### 6.3.4 Output Clock Configuration Registers

**Register Name:** OCxCR1  
**Register Description:** Output Clock x Configuration Register 1  
**Register Address:** OC1: 200h, OC2: 210h, OC3: 220h

	Bit 7	Bit 6	Bit 5	Bit 4	Bit 3	Bit 2	Bit 1	Bit 0
<b>Name</b>	PHEN	MSDIV[6:0]						
<b>Default</b>	0	0	0	0	0	0	0	0

**Bit 7: Phase Adjust Enable (PHEN).** This bit enables this output to participate in phase adjustment/alignment. See section [5.7.4](#).

- 0 = Phase adjustment/alignment disabled for this output
- 1 = Phase adjustment/alignment enabled for this output

**Bits 6 to 0: Medium-Speed Divider Value (MSDIV[6:0]).** This field specifies the setting for the output clock's medium-speed divider. The divisor is MSDIV+1. Note that if MSDIV is not set to 0 (bypass) then MSDIV must be set to a value that causes the output clock of the medium-speed divider to be 425MHz or less. When MSDIV=0, the medium-speed divider, phase adjust, low-speed divider, start/stop and output duty cycle adjustment circuits are bypassed and the high-frequency clock signal is directly sent to the output driver. See section [5.7.2](#).

**Register Name:** OCxCR2  
**Register Description:** Output Clock x Configuration Register 2  
**Register Address:** OC1: 201h, OC2: 211h, OC3: 221h

	Bit 7	Bit 6	Bit 5	Bit 4	Bit 3	Bit 2	Bit 1	Bit 0
<b>Name</b>	—	POL	DRIVE[1:0]		STOPDIS	OCSF[2:0]		
<b>Default</b>	0	0	0	0	0	0	0	0

**Bit 6: Clock Path Polarity (POL).** The clock path to the CML, HSTL and CMOS outputs is inverted when this bit set. This does not invert the LSDIV path to the CMOS OCxN pin if that path is enabled. See section 5.7.1.

**Bits 5 to 4: CMOS/HSTL Output Drive Strength (DRIVE[1:0]).** The CMOS/HSTL output drivers have four equal sections that can be enabled or disabled to achieve four different drive strengths from 1x to 4x. When the output power supply VDDOx is 3.3V or 2.5V, the user should start with 1x and only increase drive strength if the output is highly loaded and signal transition time is unacceptable. When VDDOx is 1.8V or 1.5V the user should start with 4x and only decrease drive strength if the output signal has unacceptable overshoot. See section 5.7.1.

00 = 1x

01 = 2x

10 = 3x

11 = 4x

**Bit 3: Stop Disable (STOPDIS).** This bit causes the output to become disabled (high impedance) while the output clock is stopped. See section 5.7.5.

0 = Do not disable the output while stopped

1 = Disable the output while stopped

**Bits 2 to 0: Output Clock Signal Format (OCSF[2:0]).** Note that `OCEN.OCxEN=0` forces the output driver to be high-impedance regardless of the value of the OCSF register field. See section 5.7.1.

000 = Disabled (high-impedance, low power mode)

001 = CML, standard swing ( $V_{OD} = 800mV_{P-P}$  typical)

010 = CML, narrow swing ( $V_{OD} = 400mV_{P-P}$  typical)

011 = HSTL (Set `OCxCR2.DRIVE=11` (4x) to meet JESD8-6)

100 = Two CMOS: OCxP in phase with OCxN

101 = One CMOS: OCxP high impedance, OCxN enabled

110 = One CMOS: OCxP enabled, OCxN high impedance

111 = Two CMOS: OCxP inverted vs. OCxN

**Register Name:** OCxCR3  
**Register Description:** Output Clock x Configuration Register 3  
**Register Address:** OC1: 202h, OC2: 212h, OC3: 222h

	Bit 7	Bit 6	Bit 5	Bit 4	Bit 3	Bit 2	Bit 1	Bit 0
<b>Name</b>	SRLSEN	DIVSEL	NEGLSD	LSSEL	—	—	—	LSDIV[24]
<b>Default</b>	0	0	0	0	0	0	0	0

**Bit 7 Enable LSDIV Statuses (SRLSEN).** This bit enables the [OCxSR.LSCLK](#) real-time status bit and its associated latched status bit [OCxSR.LSCLKL](#).

- 0 = LSCLK status bit is not enabled (low)
- 1 = LSCLK status bit is enabled

**Bit 6: High Speed Divider Select (DIVSEL).** This bit selects which high-speed divider is the source of the clock for the output. See section [5.7.2](#).

- 0 = HSDIV1
- 1 = HSDIV2

**Bit 5: OCxN Low Speed Divider (NEGLSD).** This bit selects the source of the clock on the OCxN pin in CMOS mode. See section [5.7.2](#).

- 0 = Same as OCxP
- 1 = Output of the LSDIV divider

Note: NEGLSD should only be set to one in two-CMOS mode ([OCxCR2.OCSF](#)=100 or 111) and when [OCxCR2.POL](#)=0.

**Bit 4: LSDIV Select (LSSEL).** This bit selects the source of the output clock. When the MSDIV divider is selected (LSSEL=0) the LSDIV divider output can be independently selected as the source for the OCxN pin (in CMOS output mode) or monitored by the [OCxSR.LSCLK](#) status bit. This bit is only valid when [OCxCR1.MSDIV](#) > 0. See section [5.7.2](#).

- 0 = The output clock is sourced from the MSDIV divider.
- 1 = The output clock is sourced from the LSDIV divider.

**Bit 0: Low-Speed Divider Value (LSDIV[24]).** See the [OCxDIV1](#) register description.

**Register Name:** OCxDIV1  
**Register Description:** Output Clock x Divider Register 1  
**Register Address:** OC1: 203h, OC2: 213h, OC3: 223h

	Bit 7	Bit 6	Bit 5	Bit 4	Bit 3	Bit 2	Bit 1	Bit 0
<b>Name</b>	LSDIV[7:0]							
<b>Default</b>	0	0	0	0	0	0	0	0

**Bits 7 to 0: Low-Speed Divider Value (LSDIV[7:0]).** The full 25-bit LSDIV[24:0] field spans this register, OCxDIV2, OCxDIV3, and bit 0 of OCxCR3. LSDIV is an unsigned integer. The frequency of the clock from the medium-speed divider is divided by LSDIV+1. The OCxCR3.LSSEL and NEGLSD bits control when the output of the low-speed divider is present on the OCxP and OCxN output pins. OCxCR1.MSDIV must be > 0 for the low-speed divider to operate. See section 5.7.2.

**Register Name:** OCxDIV2  
**Register Description:** Output Clock x Divider Register 2  
**Register Address:** OC1: 204h, OC2: 214h, OC3: 224h

	Bit 7	Bit 6	Bit 5	Bit 4	Bit 3	Bit 2	Bit 1	Bit 0
<b>Name</b>	LSDIV[15:8]							
<b>Default</b>	0	0	0	0	0	0	0	0

**Bits 7 to 0: Low-Speed Divider Value (LSDIV[15:8]).** See the OCxDIV1 register description.

**Register Name:** OCxDIV3  
**Register Description:** Output Clock x Divider Register 3  
**Register Address:** OC1: 205h, OC2: 215h, OC3: 225h

	Bit 7	Bit 6	Bit 5	Bit 4	Bit 3	Bit 2	Bit 1	Bit 0
<b>Name</b>	LSDIV[23:16]							
<b>Default</b>	0	0	0	0	0	0	0	0

**Bits 7 to 0: Low-Speed Divider Value (LSDIV[23:16]).** See the OCxDIV1 register description.

**Register Name:** OCxDC  
**Register Description:** Output Clock x Duty Cycle Register  
**Register Address:** OC1: 206h, OC2: 216h, OC3: 226h

	Bit 7	Bit 6	Bit 5	Bit 4	Bit 3	Bit 2	Bit 1	Bit 0
<b>Name</b>	OCDC[7:0]							
<b>Default</b>	0	0	0	0	0	0	0	0

**Bits 7 to 0: Output Clock Duty Cycle (OCDC[7:0]).** This field controls the output clock signal duty cycle when MSDIV>0 and LSDIV>1. When OCDC = 0 the output clock is 50%. Otherwise the clock signal is a pulse with a width of OCDC number of MSDIV output clock periods. The range of OCDC can create pulse widths from 1 to 255 MSDIV output clock periods. When OCxCR2.POL=0, the pulse is high and the signal is low the remainder of the cycle. When POL=1, the pulse is low and the signal is high the remainder of the cycle. See section 5.7.3.

Note: Rev A devices require MSDIV>5.

**Register Name:** OCxPH  
**Register Description:** Output Clock x Phase Adjust Register  
**Register Address:** OC1: 207h, OC2: 217h, OC3: 227h

	Bit 7	Bit 6	Bit 5	Bit 4	Bit 3	Bit 2	Bit 1	Bit 0
<b>Name</b>	PHADJ[7:0]							
<b>Default</b>	0	0	0	0	0	0	0	0

**Bits 7 to 0: Phase Adjust Value (PHADJ[7:0]).** When `OCxCR1.PHEN=1`, this field specifies the phase adjustment of the output clock during a phase adjustment event. When `OCxCR1.PHEN=0`, this field is ignored. The specified phase adjustment occurs once during a phase adjustment event. The format of the field is 2's-complement with the LSB being one half of an HSDIV output clock period. Positive values move the signal later in time (to the right on a scope). See section 5.7.4.

00000000 = 0.0 UI  
 00000001 = +0.5 UI  
 00000010 = +1.0 UI  
 00000011 = +1.5 UI  
 ...  
 01111110 = +63.0 UI  
 01111111 = +63.5 UI  
 10000000 = -64.0 UI  
 10000001 = -63.5 UI  
 ...  
 11111101 = -1.5 UI  
 11111110 = -1.0 UI  
 11111111 = -0.5 UI

**Register Name:** OCxSTOP  
**Register Description:** Output Clock x Start Stop Register  
**Register Address:** OC1: 208h, OC2: 218h, OC3: 228h

	Bit 7	Bit 6	Bit 5	Bit 4	Bit 3	Bit 2	Bit 1	Bit 0
<b>Name</b>	STOP	—	SRC[3:0]			MODE[1:0]		
<b>Default</b>	0	0	0	0	0	0	0	0

**Bit 7: Output Clock Stop (STOP).** When `SRC=0000`, this bit is used to stop the output clock high or low. The output stays stopped while this bit is high. See section 5.7.5.

0 = Do not stop the output clock  
 1 = Stop the output clock

**Bits 5 to 2: Output Clock Stop Source (SRC[3:0]).** This field specifies the source of the stop signal. See section 5.7.5.

0000 = STOP bit  
 0001 = The arming of a phase adjustment (signal stopped when `PASR.ARMED` is asserted; signal started when `PASR.ADJL` is asserted)  
 0010 to 0111 = {unused values}  
 1000 = GPIO0  
 1001 = GPIO1  
 1010 = GPIO2  
 1011 = GPIO3  
 1100 to 1111 = {unused values}

**Bits 1 to 0: Output Clock Stop Mode (MODE[1:0]).** This field selects the mode of the start-stop function. See section 5.7.5.

00 = Never stop

01 = Stop High: stop after rising edge of output clock, start after falling edge of output clock

10 = Stop Low: stop after falling edge of output clock, start after rising edge of output clock

11 = {unused value}

The following table shows which pin(s) stop high or low as specified above for each output signal format:

Signal Format	OCxCR2.OCSF	Pin that Stops As Specified
CML	001 or 010	OCxP
HSTL	011	OCxN
Two CMOS, OCxP in phase with OCxN	100	OCxP and OCxN
One CMOS, OCxN enabled	101	OCxN
One CMOS, OCxP enabled	110	OCxP
Two CMOS, OCxP inverted vs. OCxN	111	OCxN

Notes:

1. The highest priority condition for an output is when it is stopped and OCxCR2.STOPDIS=1. When this condition occurs both OCxP and OCxN become high-impedance regardless of the state of the control bits mentioned below.
2. When the output is not stopped or when OCxCR2.STOPDIS=0, OCxCR3.NEGLSD=1 causes the OCxN pin to follow the output clock of the low-speed divider uninverted regardless of the signal format, regardless of the state of OCxCR2.POL, and regardless of whether the output is stopped.
3. When the above situations do not apply, OCxCR2.POL=1 changes Stop High to Stop Low and vice versa.

### 6.3.5 Input Clock Configuration Registers

**Register Name:** ICxCR1  
**Register Description:** Input Clock x Configuration Register 1  
**Register Address:** IC1: 300h, IC2: 320h, IC3: 340h

	Bit 7	Bit 6	Bit 5	Bit 4	Bit 3	Bit 2	Bit 1	Bit 0
Name	—	POL	—	—	—	—	HSDIV[1:0]	
Default	0	0	0	0	0	0	0	0

**Bit 6: Locking Polarity (POL).** This field specifies which input clock signal edge the APLL will lock to. See section 5.6.1.

0 = Rising edge  
 1 = Falling edge

**Bits 1 to 0: Input Clock High-Speed Divider (HSDIV[1:0]).** This field specifies the divide value for the input clock high-speed divider. See section 5.6.1.

00 = Divide by 1  
 01 = Divide by 2  
 10 = Divide by 4  
 11 = Divide by 8

### 6.3.6 NCO/Spread-Spectrum Configuration Registers

**Register Name:** NCSSCR1  
**Register Description:** NCO/SS Configuration Register 1  
**Register Address:** 40Bh

	Bit 7	Bit 6	Bit 5	Bit 4	Bit 3	Bit 2	Bit 1	Bit 0
Name	—	—	—	—	MODE[3:0]			
Default	0	0	0	0	0	0	0	0

**Bits 3 to 0: NCO/SS Mode (MODE[3:0]).** This field selects the operational mode of the NCO/SS block. See section 5.5.

0000: Reset  
 0001: NCO  
 0010: Spread-spectrum  
 all other values are invalid

**Register Name:** DFREQZ1  
**Register Description:** Digital Frequency Tuning Word Register 1  
**Register Address:** 420h

	Bit 7	Bit 6	Bit 5	Bit 4	Bit 3	Bit 2	Bit 1	Bit 0
Name	FREQZ[7:0]							
Default	0	0	0	0	0	0	0	0

**Bits 7 to 0: Digital Frequency Tuning Word (FREQZ[7:0]).** The full 40-bit DFREQZ[39:0] field spans this register and the [DFREQZ2](#) to [DFREQZ5](#) registers and is a multi-register field (see section [6.1.3](#)). This unsigned coefficient is the frequency tuning word value that sets the frequency the NCO/SS block generates in NCO mode. It is also the base frequency to which the NCO/SS adds a dynamic offset during spread spectrum mode. The nominal value of this field is set by the evaluation software. In NCO mode, system software can change this value by any fraction (less than 1 ppb to multiple ppm) to cause a fractional change in the device's output frequency. See section [5.5.1](#).

**Register Name:** DFREQZ2  
**Register Description:** Digital Frequency Tuning Word Register 2  
**Register Address:** 421h

	Bit 7	Bit 6	Bit 5	Bit 4	Bit 3	Bit 2	Bit 1	Bit 0
Name	FREQZ[15:8]							
Default	0	0	0	0	0	0	0	0

**Bits 7 to 0: Digital Frequency Tuning Word (FREQZ[15:8]).** See the [DFREQZ1](#) register description.

**Register Name:** DFREQZ3  
**Register Description:** Digital Frequency Tuning Word Register 3  
**Register Address:** 422h

	Bit 7	Bit 6	Bit 5	Bit 4	Bit 3	Bit 2	Bit 1	Bit 0
Name	FREQZ[23:16]							
Default	0	0	0	0	0	0	0	0

**Bits 7 to 0: Digital Frequency Tuning Word (FREQZ[23:16]).** See the [DFREQZ1](#) register description.

**Register Name:** DFREQZ4  
**Register Description:** Digital Frequency Tuning Word Register 4  
**Register Address:** 423h

	Bit 7	Bit 6	Bit 5	Bit 4	Bit 3	Bit 2	Bit 1	Bit 0
Name	FREQZ[31:24]							
Default	0	0	0	0	0	0	0	0

**Bits 7 to 0: Digital Frequency Tuning Word (FREQZ[31:24]).** See the [DFREQZ1](#) register description.

**Register Name:** DFREQZ5  
**Register Description:** Digital Frequency Tuning Word Register 5  
**Register Address:** 424h

	Bit 7	Bit 6	Bit 5	Bit 4	Bit 3	Bit 2	Bit 1	Bit 0
Name	FREQZ[39:32]							
Default	0	0	0	0	0	0	0	0

**Bits 7 to 0: Digital Frequency Tuning Word (FREQZ[39:32]).** See the [DFREQZ1](#) register description.

## 7. Electrical Characteristics

### Absolute Maximum Ratings

Parameter	Symbol	Min.	Max.	Units
Supply voltage, nominal 1.8V	VDD18	-0.3	1.98	V
Supply voltage, nominal 3.3V	VDD33	-0.3	3.63	V
Supply voltage, VDDOx (x=1,2,3)	VDDOx	-0.3	3.63	V
Voltage on XA, any ICxP/N, any OCxP/N pin	VANAPIN	-0.3	3.63	V
Voltage on any digital I/O pin	VDIGPIN	-0.3	5.5	V
Storage Temperature Range	T <sub>ST</sub>	-55	+125	°C

\* Exceeding these values may cause permanent damage. Functional operation under these conditions is not implied.

\* Voltages are with respect to ground (VSS) unless otherwise stated.

**Note 1:** The typical values listed in the tables of Section 7 are not production tested.

**Note 2:** Specifications to -40°C and 85°C are guaranteed by design or characterization and not production tested.

**Table 5 - Recommended DC Operating Conditions**

Parameter	Symbol	Min.	Typ.	Max.	Units
Supply voltage, nominal 1.8V	VDD18	1.71	1.8	1.89	V
Supply voltage, nominal 3.3V	VDD33	3.135	3.3	3.465	V
Supply voltage, VDDOx (x=1,2,3)	VDDOx	1.425	1.5	1.575	V
		1.71	1.8	1.89	
		2.375	2.5	2.625	
		3.135	3.3	3.465	
Operating temperature	T <sub>A</sub>	-40		+85	°C

**Table 6 - Electrical Characteristics: Supply Currents**

Characteristics	Symbol	Min.	Typ. <sup>1</sup>	Max	Units	Notes
Total power, one input and one normal-swing CML output enabled, XA/XB disabled	P <sub>DISS</sub>		0.57		W	
Total current, all 1.8V supply pins, NCO and SSM modes	I <sub>DD18</sub>		242	297	mA	Note 2
Total current, all 3.3V supply pins, NCO and SSM modes	I <sub>DD33</sub>		184	225	mA	Note 2
Total current, all 1.8V supply pins, APLL-only mode	I <sub>DD18</sub>		208	251	mA	Note 2
Total current, all 3.3V supply pins, APLL-only mode	I <sub>DD33</sub>		168	206	mA	Note 2
3.3V supply current change from enabling or disabling the crystal driver circuit	ΔI <sub>DD33XTAL</sub>		16		mA	
3.3V supply current change from enabling or disabling high-speed divider 2	ΔI <sub>DD33HSD</sub>		20		mA	
1.8V supply current from enabling/disabling per-output mux and dividers using OCEN.OCxEN bit	ΔI <sub>DD18ODIV</sub>		28		mA	
1.8V supply current change from enabling or disabling a CML output, standard swing	ΔI <sub>DD18CML</sub>		10		mA	
3.3V supply current change from enabling or disabling a CML output, standard swing	ΔI <sub>DD33CML</sub>		17		mA	
1.8V supply current change from enabling or disabling a CML output, narrow swing	ΔI <sub>DD18CMLN</sub>		10		mA	
3.3V supply current change from enabling or disabling a CML output, narrow swing	ΔI <sub>DD33CMLN</sub>		9		mA	
1.8V supply current change from enabling or disabling a pair of single-ended outputs	ΔI <sub>DD18CMOS</sub>		2		mA	
VDDOx supply current change from enabling or disabling a pair of single-ended outputs	ΔI <sub>DD33CMOS</sub>		16		mA	Note 3

Characteristics	Symbol	Min.	Typ. <sup>1</sup>	Max	Units	Notes
1.8V supply current change from enabling or disabling an input clock	$\Delta I_{DD18IN}$		13		mA	

**Note 1:** Typical values measured at 1.80V and 3.30V supply voltages and 25°C ambient temperature.

**Note 2:** Max  $I_{DD}$  measurements made with all blocks enabled, 650MHz signals on IC1 and IC2 inputs, 187.5MHz signal on IC3, VCO frequency of 3750MHz, both HSDIV enabled and dividing by 6, all MSDIV dividing by 2, all LSDIV dividing by 2, and all outputs enabled as full-swing CML outputs driving 156.25MHz signals. NCO or SSM modes: 114.285M XO master clock on XA. APLL-only mode: Crystal driver and doubler off, guaranteed by design.

**Note 3:**  $V_{DDOx}=3.3V$ , 1x drive strength,  $f_o=250MHz$ , 2pF load

**Table 7 - Electrical Characteristics: Non-clock CMOS Pins**

Characteristics	Symbol	Min.	Typ.	Max.	Units	Notes
Input high voltage, SCL and SDA	$V_{IH}$	0.7 x VDD33			V	
Input low voltage, SCL and SDA	$V_{IL}$			0.3 x VDD33	V	
Input high voltage, all other digital inputs	$V_{IH}$	2.0			V	
Input low voltage, all other digital inputs	$V_{IL}$			0.8	V	
Input leakage current, RSTN pin	$I_{ILPU}$	-85		10	$\mu A$	Note 1
Input leakage current, GPIO3/IC3P pin	$I_{ILGP3}$	-20		20	$\mu A$	Note 1
Input leakage current, all other digital inputs	$I_{IL}$	-10		10	$\mu A$	Note 1
Input capacitance	$C_{IN}$		3	10	pF	
Input capacitance, SCL/SCLK, SDA/MOSI	$C_{IN}$		3	11	pF	
Input hysteresis, SCL and SDA in I <sup>2</sup> C Bus Mode		0.05* VDD33			mV	
Output leakage (when high impedance)	$I_{LO}$	-10		10	$\mu A$	Note 1
Output high voltage	$V_{OH}$	2.4			V	$I_o = -3.0mA$
Output low voltage	$V_{OL}$			0.4	V	$I_o = 3.0mA$

**Note 1:**  $0V < V_{IN} < V_{DD33}$  for all other digital inputs.

**Note 2:**  $V_{OH}$  does not apply for SCL and SDA in I<sup>2</sup>C interface mode since they are open drain.

**Table 8 - Electrical Characteristics: XA Clock Input**

This table covers the case when there is no external crystal connected and an external oscillator or clock signal is connected to the XA pin.

Characteristics	Symbol	Min.	Typ.	Max.	Units	Notes
Input high voltage, XA	$V_{IH}$	1.2			V	
Input low voltage, XA	$V_{IL}$			0.8	V	
Input frequency on XA pin, master clock for NCO mode, clock doubler disabled	$f_{IN}$	80		130	MHz	
Input frequency on XA pin, internally doubled to make master clock for NCO mode	$f_{IN}$	40		65	MHz	
Input frequency on XA pin, master clock for Spread Spectrum mode, clock doubler disabled	$f_{IN}$	80		130	MHz	
Input frequency on XA pin, internally doubled to make master clock for Spread Spectrum mode	$f_{IN}$	55		65	MHz	
Input frequency, XA pin to APLL mux	$f_{IN}$	9.72		156.25	MHz	
Input frequency, XA pin to HSDIV2 bypass mux	$f_{IN}$			156.25	MHz	
Input leakage current	$I_{IL}$	-10		10	$\mu A$	
Input duty cycle		40		60	%	

**Table 9 - Electrical Characteristics: Clock Inputs, ICxP/N**

Characteristics	Symbol	Min.	Typ.	Max.	Units	Notes
Input voltage tolerance (each pin, single-ended)	$V_{TOL}$	0		VDD33	V	Note 1
Input differential voltage	$ V_{ID} $	0.1		1.4	V	Note 2
Input DC bias voltage (internally biased)	$V_{CMI}$		1.3		V	
Input frequency, ICx pins	$f_{IN}$	9.72		1250	MHz	Differential
		9.72		300	MHz	Single-ended
Minimum input clock high, low time, $f_{IN} \leq 250\text{MHz}$	$t_H, t_L$		smaller of 3ns or $0.3 \times 1 / f_{IN}$		ns	Note 5
Minimum input clock high, low time, $f_{IN} > 250\text{MHz}$	$t_H, t_L$	0.4			ns	Note 6
Input resistance, single-ended to VDD18, ICxP or ICxN	$R_{INVDD18}$		50		$k\Omega$	
Input resistance, single-ended to VSS, ICxP or ICxN	$R_{INVSS}$		80		$k\Omega$	

- Note 1:** The device can tolerate voltages as specified in  $V_{TOL}$  w.r.t. VSS on its ICxP and ICxN pins without being damaged. For differential input signals, proper operation of the input circuitry is only guaranteed when the other specifications in this table, including  $|V_{ID}|$ , are met.
- Note 2:** For inputs IC1P/N and IC2P/N  $V_{ID} = V_{ICxP} - V_{ICxN}$ . For input IC3P,  $V_{ID} = V_{IC3P} - V_{CMI}$ . The max  $V_{ID}$  spec only applies when a differential signal is applied on ICxP/N; it does not apply when a single-ended signal is applied on ICxP.
- Note 3: Differential signals.** The differential inputs can easily be interfaced to neighboring ICs driving LVDS, LVPECL, CML, HCSL, HSTL or other differential signal formats using a few external passive components. In general, Microsemi recommends terminating the signal with the termination/load recommended in the neighboring component's data sheet and then AC-coupling the signal into the ICxP/ICxN pins. See Figure 16 for details. To connect a differential signal to IC3, AC-couple one side of the signal to IC3P and AC-couple the other side to VSS. For DC-coupling, treat the input as 1.8V CML.
- Note 4: Single-ended signals** can be connected to ICxP pins. Signals with amplitude greater than 2.5V must be DC-coupled. For signals with amplitudes less than 2.5V Microsemi recommends AC-coupling but DC-coupling can also be used. When a single-ended signal is connected to ICxP, ICxN should be connected to a capacitor (0.1 $\mu$ F or 0.01 $\mu$ F) to VSS.
- Note 5:** If MCR1.MCSEL1=1 then IC1 is the NCO/SS block's master clock source and therefore the duty cycle spec in Table 8 applies to IC1 rather than the  $t_H, t_L$  spec in this table.
- Note 6:** The input high-speed divider must be used to divide the frequency by 2 or more.

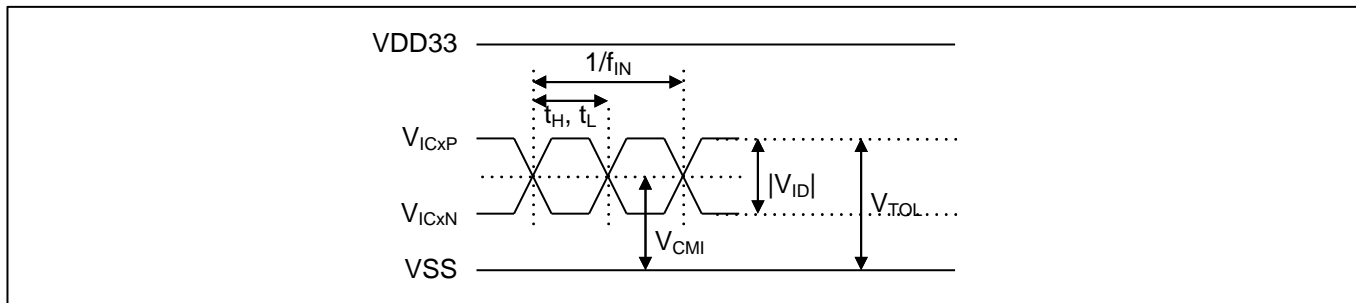

**Figure 15 - Electrical Characteristics: Clock Inputs**

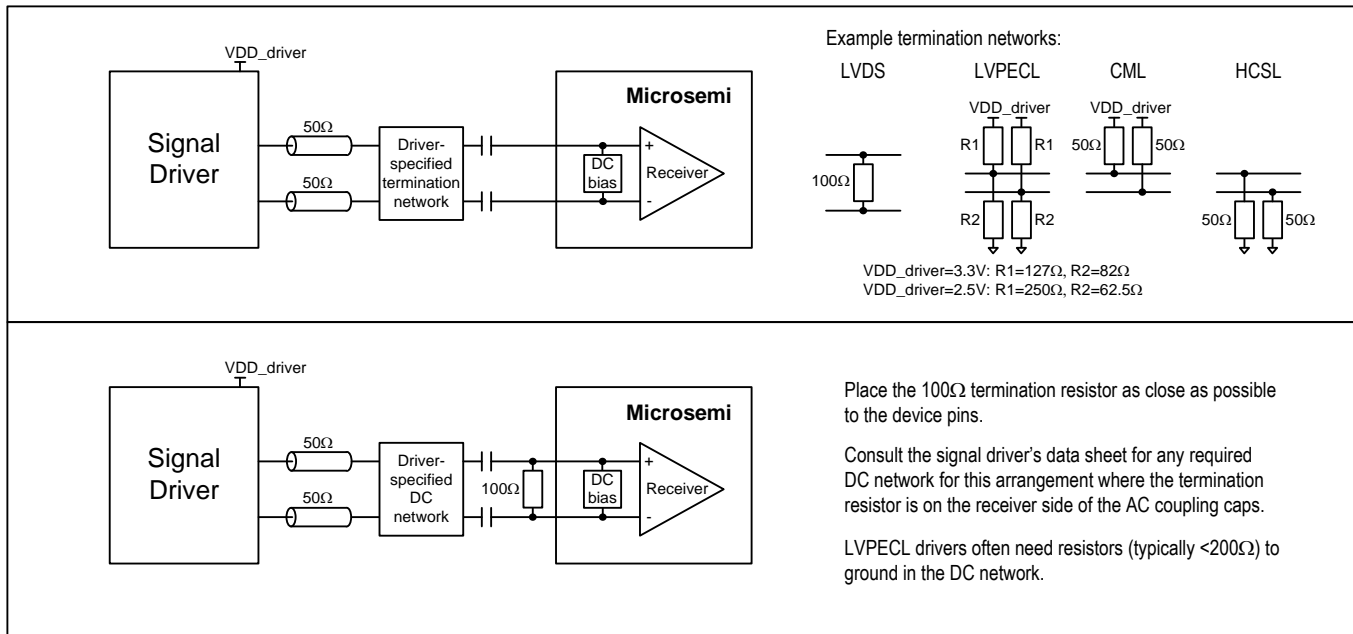

Figure 16 - Example External Components for Differential Input Signals

Table 10 - Electrical Characteristics: CML Clock Outputs

VODDx = 3.3V±5% for CML operation.

Characteristics	Symbol	Min.	Typ.	Max.	Units	Notes
Output frequency	f <sub>OCML</sub>			1035	MHz	
Output frequency from medium-speed divider	f <sub>OCML,MSDIV</sub>			425	MHz	
Output high voltage, single-ended, OCxP or OCxN	V <sub>OH,S</sub>		VDDOx - 0.2		V	Standard Swing (OCxCR2.OCSF=1), AC coupled to 50Ω termination
Output low voltage, single-ended, OCxP or OCxN	V <sub>OL,S</sub>		VDDOx - 0.6		V	
Output common mode voltage	V <sub>CM,S</sub>		VDDOx - 0.4		V	
Output differential voltage	V <sub>OD,S</sub>	320	400	500	mV	
Output differential voltage, peak-to-peak	V <sub>OD,S,PP</sub>	640	800	1000	mV <sub>P-P</sub>	
Output high voltage, single-ended, OCxP or OCxN	V <sub>OH,N</sub>		VDDOx - 0.1		V	Narrow Swing (half the power) (OCxCR2.OCSF=2), AC coupled to 50Ω termination
Output low voltage, single-ended, OCxP or OCxN	V <sub>OL,N</sub>		VDDOx - 0.3		V	
Output common mode voltage	V <sub>CM,N</sub>		VDDOx - 0.2		V	
Output differential voltage	V <sub>OD,N</sub>	160	200	250	mV	
Output differential voltage, peak-to-peak	V <sub>OD,N,PP</sub>	320	400	500	mV <sub>P-P</sub>	
Difference in Magnitude of Differential Voltage for Complementary States	V <sub>DOS</sub>			50	mV	
Output Rise/Fall Time	t <sub>R</sub> , t <sub>F</sub>		150		ps	20%-80%
Output Duty Cycle		45	50	55	%	Notes 2
Output Duty Cycle		40		60	%	Notes 3
Output Impedance	R <sub>OUT</sub>		50		Ω	Single Ended, to VDDOx
Mismatch in a pair	ΔR <sub>OUT</sub>			10	%	

**Note 1:** The differential CML outputs can easily be interfaced to LVDS, LVPECL, CML and other differential inputs on neighboring ICs using a few external passive components. See Figure 18 for details.

**Note 2:** For all HSDIV, MSDIV and LSDIV combinations other than those specified in Note 3.

**Note 3:** For the case when `APLLCR1.HSDIV` specifies a half divide and `OCxCR1.MSDIV=0` and `OCxDIV=0`.

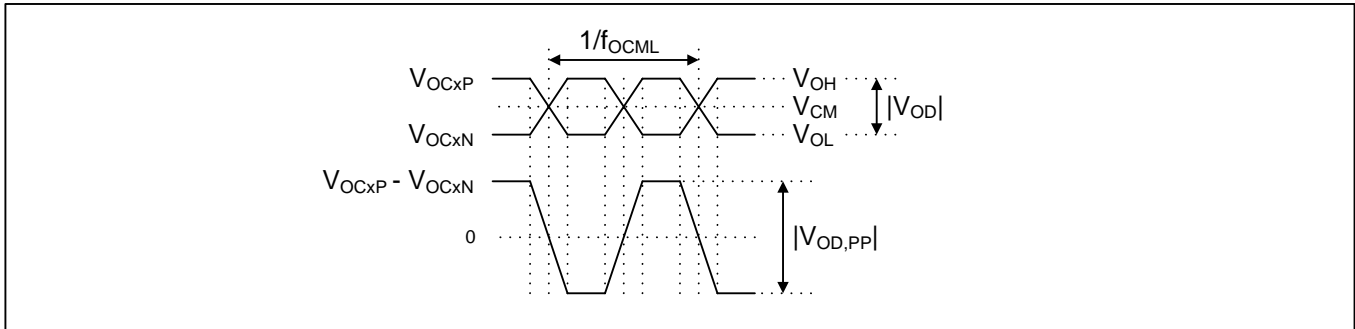

Figure 17 - Electrical Characteristics: CML Clock Outputs

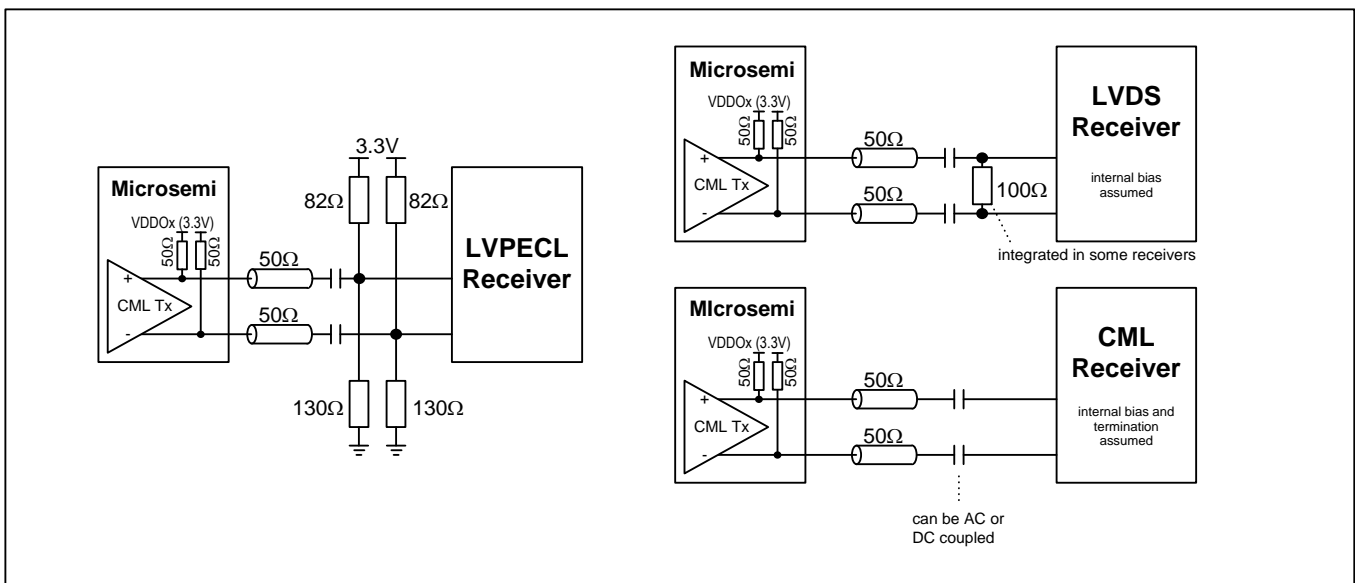

Figure 18 – Example External Components for CML Output Signals

**Table 11 - Electrical Characteristics: CMOS and HSTL (Class I) Clock Outputs**

Characteristics	Symbol	Min.	Typ.	Max.	Units	Notes
Output frequency	$f_{OCMOS}$	$\ll 1\text{Hz}$		250	MHz	Note 1
Output high voltage	$V_{OH}$	$V_{DDOx} - 0.4$		$V_{DDOx}$	V	Notes 3, 4
Output low voltage	$V_{OL}$	0		0.4	V	Notes 3, 4
Output rise/fall time, $V_{CCOx}=1.8\text{V}$ , $OCxCR2.DRIVE=4x$	$t_R, t_F$		0.4		ns	2pF load
Output rise/fall time, $V_{CCOx}=1.8\text{V}$ , $OCxCR2.DRIVE=1x$			1.2		ns	15pF load
Output rise/fall time, $V_{CCOx}=3.3\text{V}$ , $OCxCR2.DRIVE=1x$			0.7		ns	2pF load
Output rise/fall time, $V_{CCOx}=3.3\text{V}$ , $OCxCR2.DRIVE=4x$			2.2		ns	15pF load
Output duty cycle		45	50	55	%	Note 5
Output duty cycle		42	50	58	%	Notes 6, 7
Output duty cycle, $OCxNEG$ single-ended			50		%	Note 6
Output duty cycle, $OCxPOS$ single-ended			46		%	Note 6
Output current when output disabled			10		$\mu\text{A}$	$OCxCR2.OCSF=0$

**Note 1:** Minimum output frequency is a function of VCO frequency and output divider values and is guaranteed by design.

**Note 2:** Measured with a series resistor of  $33\Omega$  and a 5pF load capacitance unless otherwise specified.

**Note 3:** For HSTL Class I,  $V_{OH}$  and  $V_{OL}$  apply for both unterminated loads and for symmetrically terminated loads, i.e.  $50\Omega$  to  $V_{DDOx}/2$ .

**Note 4:** For  $V_{DDOx}=3.3\text{V}$  and  $OCxCR2.DRIVE=1x$ ,  $I_o=4\text{mA}$ . For  $V_{DDOx}=1.5\text{V}$  and  $OCxCR2.DRIVE=4x$ ,  $I_o=8\text{mA}$ .

**Note 5:** Output clock frequency  $\leq 160\text{MHz}$  or  $V_{DDOx} \geq 1.8\text{V}$ .

**Note 6:** Output clock frequency  $> 160\text{MHz}$  and  $V_{DDOx} < 1.8\text{V}$ .

**Note 7:** Measured differentially.

### Interfacing to HCSL Components

Outputs in HSTL mode with  $V_{DDOx}=1.5\text{V}$  or  $V_{DDOx}=1.8\text{V}$  can provide an HCSL signal ( $V_{OH}$  typ. 0.75V) to a neighboring component when configured as shown in Figure 19 below. For  $V_{DDOx}=1.5\text{V}$  the value of  $R_S$  should be set to  $30\Omega$  and  $OCxCR2.DRIVE$  should be set to 4x. For  $V_{DDOx}=1.8\text{V}$  the value of  $R_S$  should be set to  $20\Omega$  and  $OCxCR2.DRIVE$  should be set to 2x.

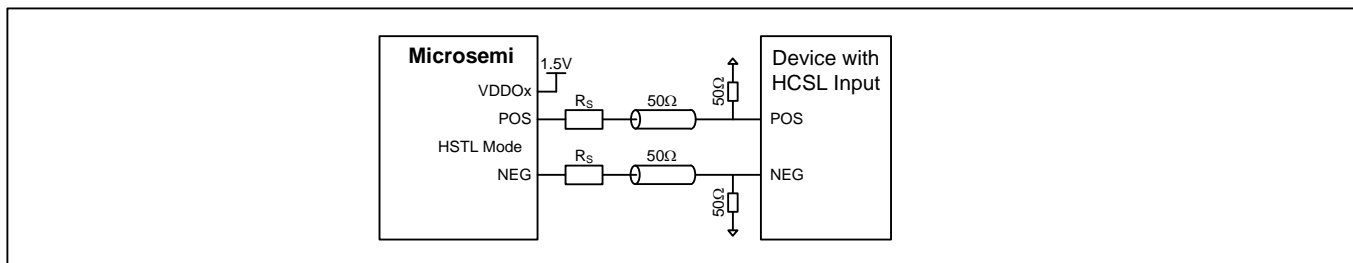
**Figure 19 – Example External Components for HCSL Output Signals**
**Table 12 - Electrical Characteristics: APLL Frequencies**

Characteristics	Symbol	Min.	Typ.	Max.	Units	Notes
APLL VCO frequency range	$f_{VCO}$	3715		4180	MHz	
APLL PFD input frequency	$f_{PFD}$	9.72		156.25	MHz	

**Table 13 - Electrical Characteristics: Jitter Specifications**

Characteristics	Min.	Typ.	Max.	Units	Notes
Output Phase Jitter, 622.08MHz		0.16	0.225	ps RMS	Notes 1, 2
Output Phase Jitter, 625MHz, (1.875MHz-20MHz)		0.06		ps RMS	Note 4
Output Period Jitter		8		ps pk-pk	N=10000, Note 5
Output Half-Period Jitter		14		ps pk-pk	N=10000, Note 5
Output Cycle-to-Cycle Jitter		7.5		ps pk	N=10000, Note 5
Jitter Transfer Bandwidth		600		kHz	Note 3
Bypass Path Additive Jitter, 100MHz in/out		0.18		ps RMS	12kHz-20MHz

**Note 1:** Jitter calculated from integrated phase noise from 12kHz to 20MHz.

**Note 2:** Tested with 155.52MHz XO (Vectron VCC1) connected to IC1, APLL VCO frequency 3732.48MHz, HSDIV1=6, OC1 frequency 622.08MHz.

**Note 3:** APLL bandwidth and damping factor can be field configured over a limited range. Contact the factory for details.

**Note 4:** With 50MHz crystal doubled as APLL input. Jitter calculated from integrated phase noise from 1.875MHz to 20MHz.

**Note 5:** Outputs from a half-divide (e.g. 4.5) in the high-speed divider followed by only an odd divide in the medium-speed divider can have higher jitter values. Example: 100MHz from VCO=3750MHz, HSDIV1=7.5, MSDIV=5 has typical period jitter of 16ps, typical cycle-to-cycle jitter of 15ps and typical half-period jitter of 58ps.

**Table 14 - Electrical Characteristics: Typical Output Jitter Performance**

Output Frequency	Output Jitter, ps RMS 125MHz XO Reference <sup>1</sup>	Output Jitter, ps RMS 50MHz Crystal Reference <sup>2</sup>
625MHz	0.155	0.185
156.25MHz	0.18	0.21
125MHz	0.19	0.21
25MHz CMOS	0.26	0.28
622.08MHz	0.25	0.27
155.52MHz	0.27	0.315
622.08MHz * 255/237	0.26	0.29
155.52MHz * 255/237	0.275	0.30
614.4MHz	0.25	0.28
153.6MHz	0.28	0.32

**Note 1:** APLL locked to external 125MHz XO (Vectron VCC1-1535-125M000).

**Note 2:** APLL locked to external 50MHz crystal (TXC 7M50070021), internal doubler enabled when multiplication is fractional.

**Note 3:** All signals are differential unless otherwise stated. Jitter is integrated 12kHz to 5MHz for 25MHz output frequency and 12kHz to 20MHz for all other output frequencies.

**Table 15 - Electrical Characteristics: Typical Input-to-Output Clock Delay**

Mode	Delay, Input Clock Edge to Output Clock Edge
All Modes	Non-deterministic but constant as long as the APLL remains locked and output clock phases are not adjusted as described in section 5.7.4.1.

**Table 16 - Electrical Characteristics: Typical Output-to-Output Clock Delay**

Mode	Delay, Output Clock Edge to Output Clock Edge
All Modes	<100ps Requires phase adjustment and phase alignment capability described in section 5.7.4.

**Table 17 - Electrical Characteristics: SPI Slave Interface Timing, Device Registers**

Characteristics (Notes 1 to 3)	Symbol	Min.	Typ.	Max.	Units	Notes
SCLK frequency	$f_{BUS}$			10	MHz	
SCLK cycle time	$t_{CYC}$	100			ns	
CSN setup to first SCLK edge	$t_{SUC}$	50			ns	
CSN hold time after last SCLK edge	$t_{HDC}$	50			ns	
CSN high time	$t_{CSH}$	50			ns	
SCLK high time	$t_{CLKH}$	40			ns	
SCLK low time	$t_{CLKL}$	40			ns	
MOSI data setup time	$t_{SUI}$	10			ns	
MOSI data hold time	$t_{HDI}$	10			ns	
MISO enable time from SCLK edge	$t_{EN}$	0			ns	
MISO disable time from CSN high	$t_{DIS}$			80	ns	
MISO data valid time	$t_{DV}$			40	ns	
MISO data hold time from SCLK edge	$t_{HDO}$	0			ns	
CSN, MOSI input rise time, fall time	$t_R, t_F$			10	ns	

- Note 1:** All timing is specified with 100pF load on all SPI pins.
- Note 2:** All parameters in this table are guaranteed by design or characterization.
- Note 3:** See timing diagram in [Figure 20](#).

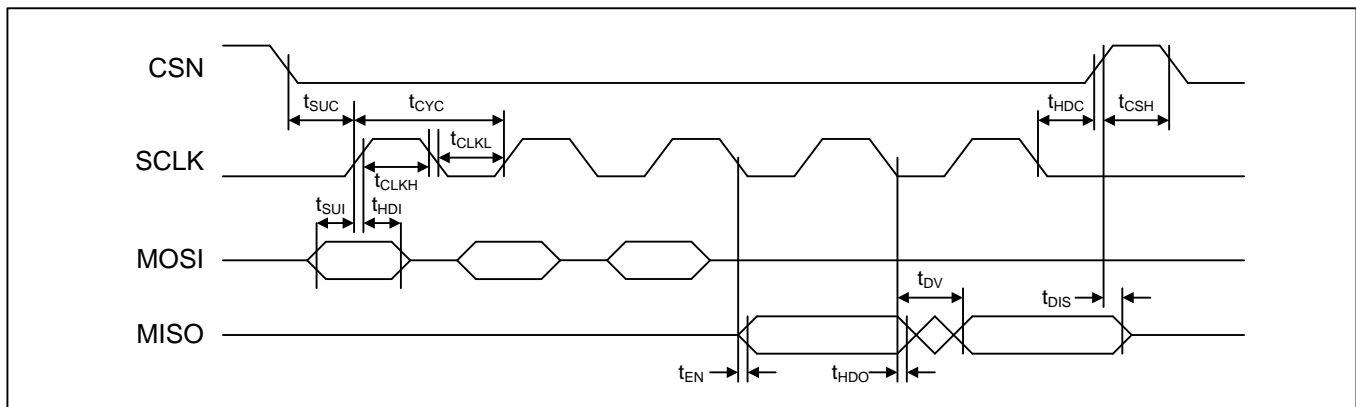

**Figure 20 - SPI Slave Interface Timing**

**Table 18 - Electrical Characteristics: SPI Slave Interface Timing, Internal EEPROM (ZL30251 Only)**

Characteristics (Notes 1 to 4)	Symbol	Min.	Typ.	Max.	Units	Notes
SCLK frequency	$f_{\text{BUS}}$			10	MHz	
SCLK cycle time	$t_{\text{CYC}}$	100			ns	
CSN setup to first SCLK edge	$t_{\text{SUC}}$	50			ns	
CSN hold time after last SCLK edge	$t_{\text{HDC}}$	51			ns	
CSN high time	$t_{\text{CSH}}$	51			ns	
SCLK high time	$t_{\text{CLKH}}$	41			ns	
SCLK low time	$t_{\text{CLKL}}$	41			ns	
MOSI data setup time	$t_{\text{SUI}}$	11			ns	
MOSI data hold time	$t_{\text{HDI}}$	11			ns	
MISO enable time from SCLK edge	$t_{\text{EN}}$	0			ns	
MISO disable time from CSN high	$t_{\text{DIS}}$			90	ns	
MISO data valid time	$t_{\text{DV}}$			60	ns	
MISO data hold time from SCLK edge	$t_{\text{HDO}}$	0			ns	
CSN, MOSI input rise time, fall time	$t_{\text{R}}, t_{\text{F}}$			10	ns	

**Note 1:** This timing applies (a) when  $\text{EESEL}=1$  and (b) in direct EEPROM write mode (see section 5.12.2).

**Note 2:** All timing is specified with 100pF load on all SPI pins.

**Note 3:** All parameters in this table are guaranteed by design or characterization.

**Note 4:** See timing diagram in Figure 20.

**Table 19 - Electrical Characteristics: SPI Master Interface Timing (ZL30250 Only)**

Characteristics (Notes 1 to 3)	Symbol	Min.	Typ.	Max.	Units	Notes
SCLK output frequency	$f_{BUS}$			5	MHz	
SCLK output cycle time	$t_{CYC}$	200			ns	
SCLK output duty cycle	$t_{CLKH}/t_{CYC}$	45	50	55	%	
CSN output setup to first SCLK rising edge	$t_{SUC}$	200			ns	
CSN output hold after last SCLK falling edge	$t_{HDC}$	200			ns	
CSN output high time	$t_{CSH}$	200			ns	
MISO input setup time to SCLK rising edge	$t_{SU}$	15			ns	
MISO input hold time from SCLK rising edge	$t_{HD}$	5			ns	
MOSI output valid from SCLK falling edge	$t_{DV}$			10	ns	
SCLK, CSN, MOSI output rise time, fall time	$t_R, t_F$			15	ns	
MISO input rise time, fall time	$t_R, t_F$			10	ns	

- Note 1:** All timing is specified with 100pF load on all SPI pins.
- Note 2:** All parameters in this table are guaranteed by design or characterization.
- Note 3:** See timing diagram in [Figure 21](#).

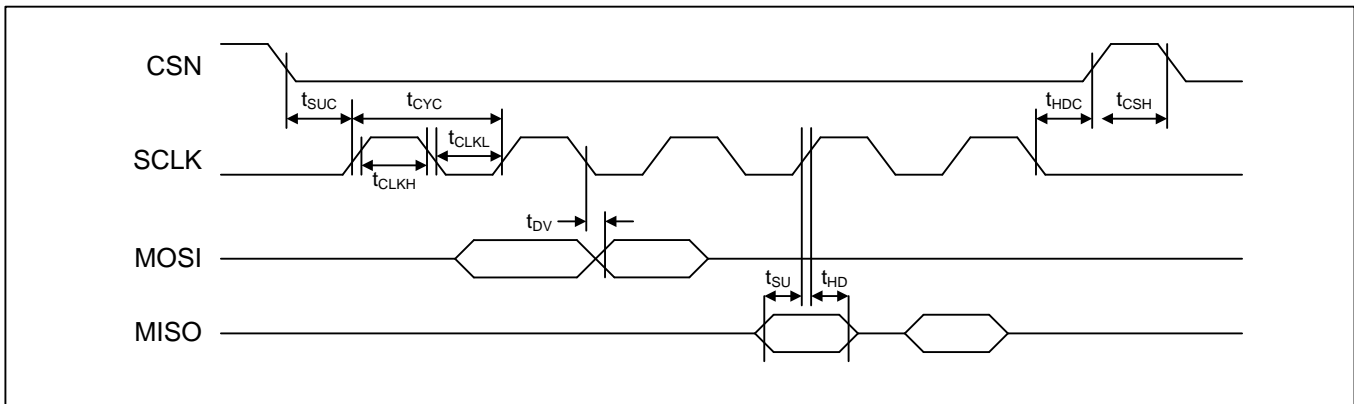

**Figure 21 - SPI Master Interface Timing**

**Table 20 - Electrical Characteristics: I<sup>2</sup>C Slave Interface Timing**

Characteristics	Symbol	Min.	Typ.	Max.	Units	Notes
SCL clock frequency	f <sub>SCL</sub>			400	kHz	
Hold time, START condition	t <sub>HD:STA</sub>	0.6			μs	
Low time, SCL	t <sub>LOW</sub>	1.3			μs	
High time, SCL	t <sub>HIGH</sub>	0.6			μs	
Setup time, START condition	t <sub>SU:STA</sub>	0.6			μs	
Data hold time	t <sub>HD:DAT</sub>	0		0.9	μs	Notes 2 and 3
Data setup time	t <sub>SU:DAT</sub>	100			ns	
Rise time	t <sub>R</sub>				ns	Note 4
Fall time	t <sub>F</sub>	20 + 0.1C <sub>b</sub>		300	ns	C <sub>b</sub> is cap. of one bus line
Setup time, STOP condition	t <sub>SU:STO</sub>	0.6			μs	
Bus free time between STOP/START	t <sub>BUF</sub>	1.3			μs	
Pulse width of spikes which must be suppressed by the input filter	t <sub>SP</sub>	0		50	ns	

**Note 1:** The timing parameters in this table are specifically for 400kbps Fast Mode. Fast Mode devices are downward-compatible with 100kbps Standard Mode I<sup>2</sup>C bus timing. All parameters in this table are guaranteed by design or characterization. All values referred to V<sub>IHmin</sub> and V<sub>ILmax</sub> levels (see Table 7).

**Note 2:** The device internally provides a hold time of at least 300ns for the SDA signal (referred to the V<sub>IHmin</sub> of the SCL signal) to bridge the undefined region of the falling edge of SCL. Other devices must provide this hold time as well per the I<sup>2</sup>C specification.

**Note 3:** The I<sup>2</sup>C specification indicates that the maximum t<sub>HD:DAT</sub> spec only has to be met if the device does not stretch the low period (t<sub>LOW</sub>) of the SCL signal. The device does not stretch the low period of the SCL signal.

**Note 4:** Determined by choice of pull-up resistor.

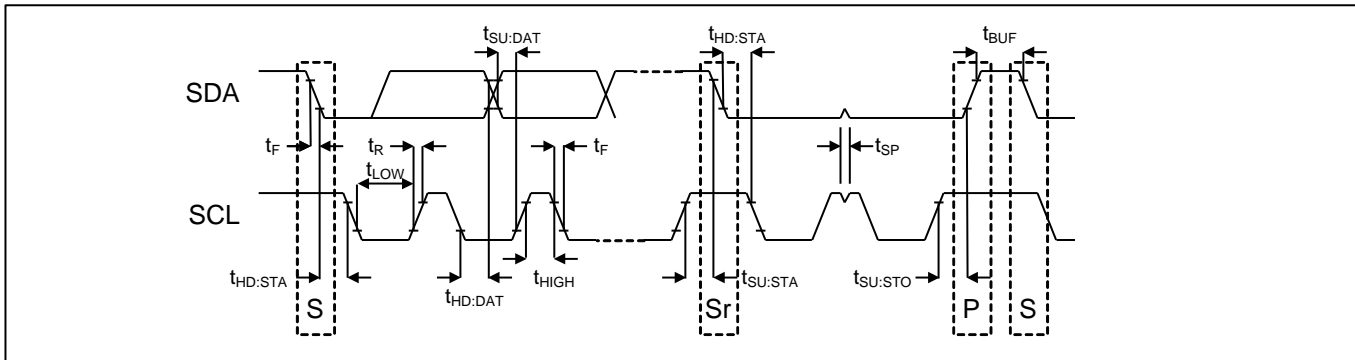

**Figure 22 - I<sup>2</sup>C Slave Interface Timing**

## 8. Package and Thermal Information

### 8.1 Package Top Mark Format

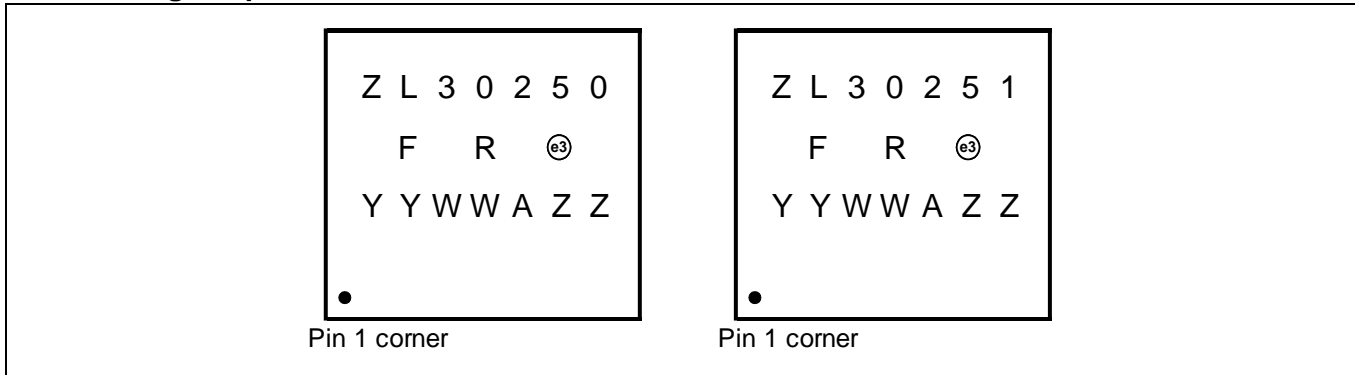

Figure 23 - Non-customized Device Top Mark

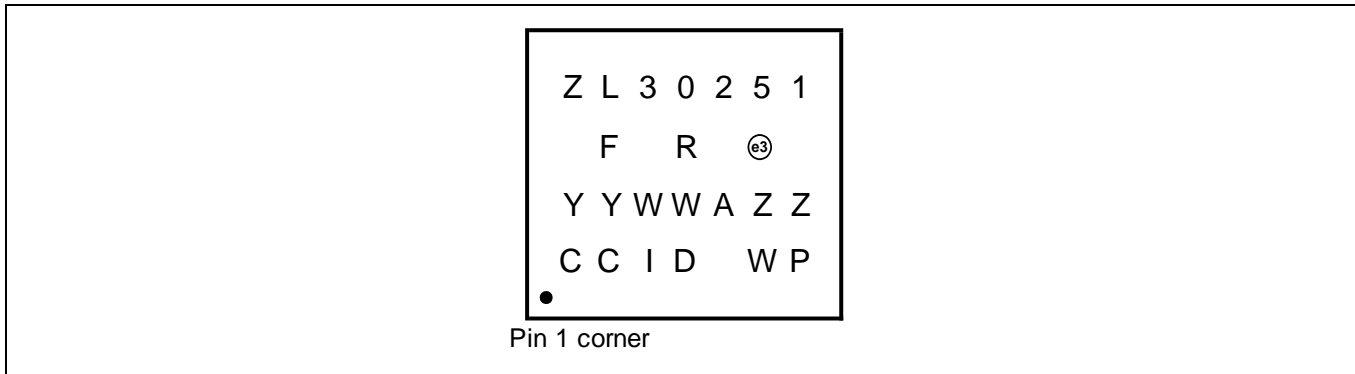

Figure 24 - Custom Factory Programmed Device Top Mark

Table 21 – Package Top Mark Legend

Line	Characters	Description
1	ZL30250 or ZL30251	Part Number
2	F	Fab Code
2	R	Product Revision Code
2	e3	Denotes Pb-Free Package
3	YY	Last Two Digits of the Year of Encapsulation
3	WW	Work Week of Assembly
3	A	Assembly Location Code
3	ZZ	Assembly Lot Sequence
4	CCID	Custom Programming Identification Code
4	WP	Work Week of Programming

## 8.2 Thermal Specifications

**Table 22 - 5x5mm QFN Package Thermal Properties**

PARAMETER	SYMBOL	CONDITIONS	VALUE	UNITS
Maximum Ambient Temperature	$T_A$		85	°C
Maximum Junction Temperature	$T_{JMAX}$		125	°C
Junction to Ambient Thermal Resistance (Note 1)	$\theta_{JA}$	still air	29.6	°C/W
		1m/s airflow	23.3	
		2.5m/s airflow	20.6	
Junction to Board Thermal Resistance	$\theta_{JB}$		9.8	°C/W
Junction to Case Thermal Resistance	$\theta_{JC}$		17.5	°C/W
Junction to Pad Thermal Resistance (Note 2)	$\theta_{JP}$	Still air	3.4	°C/W
Junction to Top-Center Thermal Characterization Parameter	$\Psi_{JT}$	Still air	0.2	°C/W

**Note 1:** Theta-JA ( $\theta_{JA}$ ) is the thermal resistance from junction to ambient when the package is mounted on an 4-layer JEDEC standard test board and dissipating maximum power.

**Note 2:** Theta-JP ( $\theta_{JP}$ ) is the thermal resistance from junction to the center exposed pad on the bottom of the package.

**Note 3:** For all numbers in the table, the exposed pad is connected to the ground plane with a 5x5 array of thermal vias; via diameter 0.33mm; via pitch 0.76mm.

9. Mechanical Drawing

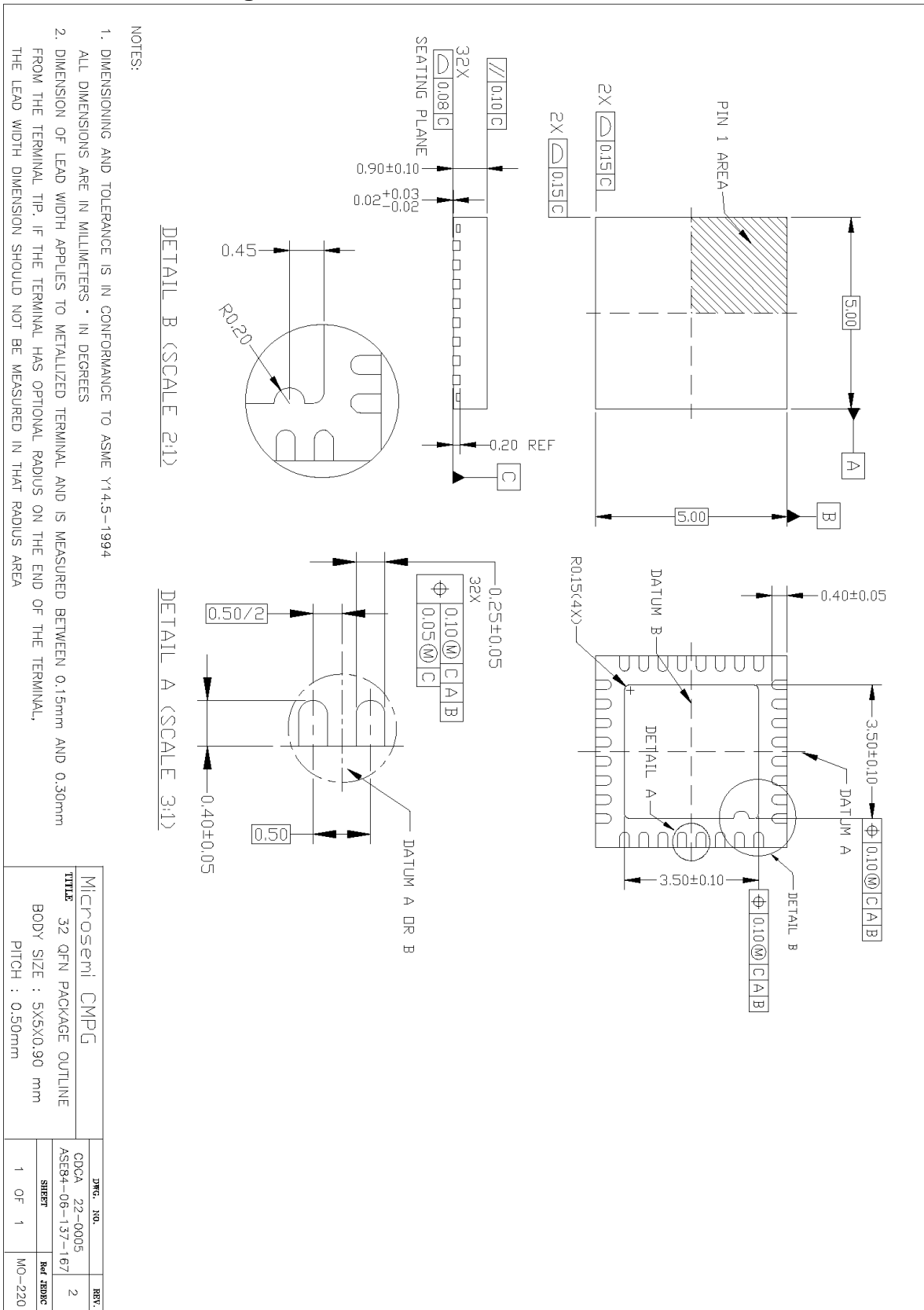

## 10. Acronyms and Abbreviations

APLL	analog phase locked loop
CML	current mode logic
GbE	gigabit Ethernet
HCSL	high-speed current steering logic
HSTL	high-speed transceiver logic
I/O	input/output
LVDS	low-voltage differential signal
LVPECL	low-voltage positive emitter-coupled logic
PFD	phase/frequency detector
PLL	phase locked loop
ppb	parts per billion
ppm	parts per million
pk-pk	peak-to-peak
RMS	root-mean-square
RO	read-only
R/W	read/write
SS or SSM	spread spectrum modulation
TCXO	temperature-compensated crystal oscillator
UI	unit interval
UI <sub>PP</sub> or UI <sub>P-P</sub>	unit interval, peak to peak
XO	crystal oscillator

## 11. Data Sheet Revision History

Revision	Description
23-Jun-2014	First general release
07-Jul-2014	In <a href="#">Table 6</a> added $\Delta I_{DD18ODIV}$ spec., added typical power spec for DPLL+APLL with one input and one output enabled and corrected the $\Delta I_{DD}$ numbers to match device characterization. In <a href="#">Table 8</a> changed XA $V_{IH}$ min from 1.65V to 1.2V. In <a href="#">Table 13</a> added phase jitter for 625MHz measured 1.875-20MHz, period jitter and cycle-to-cycle jitter plus Note 4.
07-Aug-2014	Changed title to Any-to-Any. In <a href="#">Table 1</a> , in ICx row changed the note about IC3 to delete the recommendation to AC-couple the NEG trace to VSS. Above <a href="#">Figure 19</a> specified $R_S$ should be set to $30\Omega$ and <a href="#">OCxCR2.DRIVE</a> should be set to 4x.
29-Sep-2014	Corrected references to section 0. Edited section 5.4 to match the <a href="#">Table 1</a> edit done 07-Aug-2014. In <a href="#">Table 13</a> , reduced typical period jitter to 8ps and typical cycle-to-cycle jitter to 7.5ps. In both specs removed "100MHz" from the name and changed N=50000 to N=10000. Added half-period jitter spec and footnote 5. Added section 8.1 to document package top mark.
31-Mar-2015	In section 5.2.1 changed the first three rows of the table to to have AC1=0, AC0=0 rather than AC1=X, AC0=X to match the implementation. In section 5.2 added two guidelines to ensure the device properly samples the reset values of TEST, IF[1:0] and AC[1:0] pins. In section 5.10 change min reset assert time from 100ns to 100ms to ensure AC0/GPIO0, AC1/GPIO1, TEST/GPIO2, IF0/CSN and IF1/MISO pads have enough time to set up their "latched at reset" values. Also added that system software must wait for for

Revision	Description
	<p><b>GLOBALSR</b>.BCDONE=1 before configuring the device.</p> <p>In <a href="#">Table 20</a> Note 1 clarified device compatibility with I<sup>2</sup>C 400kbps Fast Mode and 100kbps Standard Mode.</p> <p>In section <a href="#">5.12.2</a> specified that MISO is driven continually during Direct EEPROM Write Mode.</p> <p>Documented the 100 and 101 decodes of <a href="#">APLLCR3</a>.APLLMUX.</p> <p>Changed the VDDO1, VDDO2, VDDO3 descriptions in <a href="#">Table 1</a> to clearly indicate that VDDO1 is for output OC1, VDDO2 is for output OC2, etc.</p> <p>Deleted section 5.14.1, renamed and rewrote section 5.12.2 (which became new section <a href="#">5.12.1</a>) and renamed section <a href="#">5.12</a>.</p> <p>Modified <a href="#">Figure 18</a>. In the LVDS diagram removed the 5k<math>\Omega</math> resistors to ground, which are only appropriate for one type of LVDS receiver design. Added 100<math>\Omega</math> differential termination and note about how it may be integrated in some receivers. Added note that internal bias and termination is assumed for the CML receiver diagram.</p> <p>Edited the <i>Interfacing to HCSL Components</i> discussion on page <a href="#">68</a> to include a recommendation for HCSL when VDDOx=1.8V.</p> <p>In <a href="#">Table 13</a> added bypass path additive jitter spec.</p> <p>In section <a href="#">5.5</a> deleted the last sentence: "An external crystal and the internal crystal driver circuit cannot be used with the NCO/SS block."</p> <p>Changed product title on page 1 from 3-input to 4-input.</p> <p>Added section <a href="#">5.12.3</a>, Holding Other Devices in Reset During Auto-Configuration.</p>
28-Mar-2016	<p>In the <a href="#">ID2</a> description corrected the bit 0 default value to 1.</p> <p>Corrected <a href="#">Figure 4</a> to have square corners rather than chamfered corners to match the mechanical drawing in section <a href="#">9</a>.</p> <p>Added Note 3 to <a href="#">Table 22</a>.</p> <p>In <a href="#">Table 9</a> changed <math>t_H</math>, <math>t_L</math> specs for <math>f_{IN} &gt; 250\text{MHz}</math> from <math>0.4/f_{IN}</math> typical to 0.4ns min and added Note 6.</p> <p>Edited section <a href="#">5.10</a> to reduce RSTN assertion time for all but one specific situation.</p> <p>Added a note to the <a href="#">MCR1</a>.RST description to indicate the need to clear the MCSEL, MCSEL1 and ROCD bits before setting the RST bit.</p> <p>In section <a href="#">5.8.3</a> in the Read Transactions paragraph added a note describing the case where the I<sup>2</sup>C write is separated in time from the I<sup>2</sup>C read.</p>
23-Jan-2018	<p>In section <a href="#">5.7.2</a> second paragraph added maximum input frequency sentences for the medium-speed and low-speed dividers.</p> <p>In section <a href="#">6</a> changed the end of the address range from 0x1FF to 0x6FF to include test registers.</p> <p>In the <a href="#">EESEL</a> register description, added a note that the EESEL bit is write-only.</p> <p>In <a href="#">Table 1</a>, in the SCL/SCLK and SDA/MOSI pin descriptions added notes indicating the need for an external pullup resistor for I<sup>2</sup>C operation and referring the reader to the I<sup>2</sup>C specification for details.</p> <p>In <a href="#">OCxPH</a> register description, indicated that positive values represent later in time.</p> <p>In the <a href="#">APLLCR4</a> register description indicated that "increment" moves the signal later in time and "decrement" moves the signal earlier in time.</p>



Microsemi Corporate Headquarters  
One Enterprise  
Aliso Viejo, CA 92656 USA

**Within the USA:** +1 (800) 713-4113  
**Outside the USA:** +1 (949) 380-6100  
**Sales:** +1 (949) 380-6136  
**Fax:** +1 (949) 215-4996

**E-mail:** [sales.support@microsemi.com](mailto:sales.support@microsemi.com)

©2018 Microsemi Corporation. All rights reserved. Microsemi and the Microsemi logo are trademarks of Microsemi Corporation. All other trademarks and service marks are the property of their respective owners.

Microsemi Corporation (Nasdaq: MSCC) offers a comprehensive portfolio of semiconductor and system solutions for communications, defense & security, aerospace and industrial markets. Products include high-performance and radiation-hardened analog mixed-signal integrated circuits, FPGAs, SoCs and ASICs; power management products; timing and synchronization devices and precise time solutions, setting the world's standard for time; voice processing devices; RF solutions; discrete components; security technologies and scalable anti-tamper products; Power-over-Ethernet ICs and midspans; as well as custom design capabilities and services. Microsemi is headquartered in Aliso Viejo, Calif., and has approximately 3,400 employees globally. Learn more at [www.microsemi.com](http://www.microsemi.com).

---

Microsemi makes no warranty, representation, or guarantee regarding the information contained herein or the suitability of its products and services for any particular purpose, nor does Microsemi assume any liability whatsoever arising out of the application or use of any product or circuit. The products sold hereunder and any other products sold by Microsemi have been subject to limited testing and should not be used in conjunction with mission-critical equipment or applications. Any performance specifications are believed to be reliable but are not verified, and Buyer must conduct and complete all performance and other testing of the products, alone and together with, or installed in, any end-products. Buyer shall not rely on any data and performance specifications or parameters provided by Microsemi. It is the Buyer's responsibility to independently determine suitability of any products and to test and verify the same. The information provided by Microsemi hereunder is provided "as is, where is" and with all faults, and the entire risk associated with such information is entirely with the Buyer. Microsemi does not grant, explicitly or implicitly, to any party any patent rights, licenses, or any other IP rights, whether with regard to such information itself or anything described by such information. Information provided in this document is proprietary to Microsemi, and Microsemi reserves the right to make any changes to the information in this document or to any products and services at any time without notice.

## Looking for pricing, stock, or lifecycle information?

Click below to explore more details on WIN SOURCE:

- ⊖ [View ZL30251LDF1 on WIN SOURCE](#)
- ⊖ [Microchip Technology](#) Information

## Optimize Your Supply Chain with WIN SOURCE Solutions

- ✓ Global Sourcing Solution
- ✓ Obsolete Management
- ✓ Cost Control Management
- ✓ Shortage Management
- ✓ Alternative Solution
- ✓ Excess Inventory Management