



**THE DATASHEET OF  
MAX31865AAP+**



## General Description

The MAX31865 is an easy-to-use resistance-to-digital converter optimized for platinum resistance temperature detectors (RTDs). An external resistor sets the sensitivity for the RTD being used and a precision delta-sigma ADC converts the ratio of the RTD resistance to the reference resistance into digital form. The MAX31865's inputs are protected against overvoltage faults as large as  $\pm 45V$ . Programmable detection of RTD and cable open and short conditions is included.

## Applications

- Industrial Equipment
- Medical Equipment
- Instrumentation

*Ordering Information appears at end of data sheet.*

## Benefits and Features

- Integration Lowers System Cost, Simplifies Design Efforts, and Reduces Design Cycle Time
  - Simple Conversion of Platinum RTD Resistance to Digital Value
  - Handles  $100\Omega$  to  $1k\Omega$  (at  $0^\circ C$ ) Platinum RTDs (PT100 to PT1000)
  - Compatible with 2-, 3-, and 4-Wire Sensor Connections
  - SPI-Compatible Interface
  - 20-Pin TQFN and SSOP Packages
- High Accuracy Facilitates Meeting Error Budgets
  - 15-Bit ADC Resolution; Nominal Temperature Resolution  $0.03125^\circ C$  (Varies Due to RTD Nonlinearity)
  - Total Accuracy Over All Operating Conditions:  $0.5^\circ C$  (0.05% of Full Scale) max
  - Fully Differential  $V_{REF}$  Inputs
  - 21ms (max) Conversion Time
- Integrated Fault Detection Increases System Reliability
  - $\pm 45V$  Input Protection
  - Fault Detection (Open RTD Element, RTD Shorted to Out-of-Range Voltage, or Short Across RTD Element)

## Typical Application Circuits

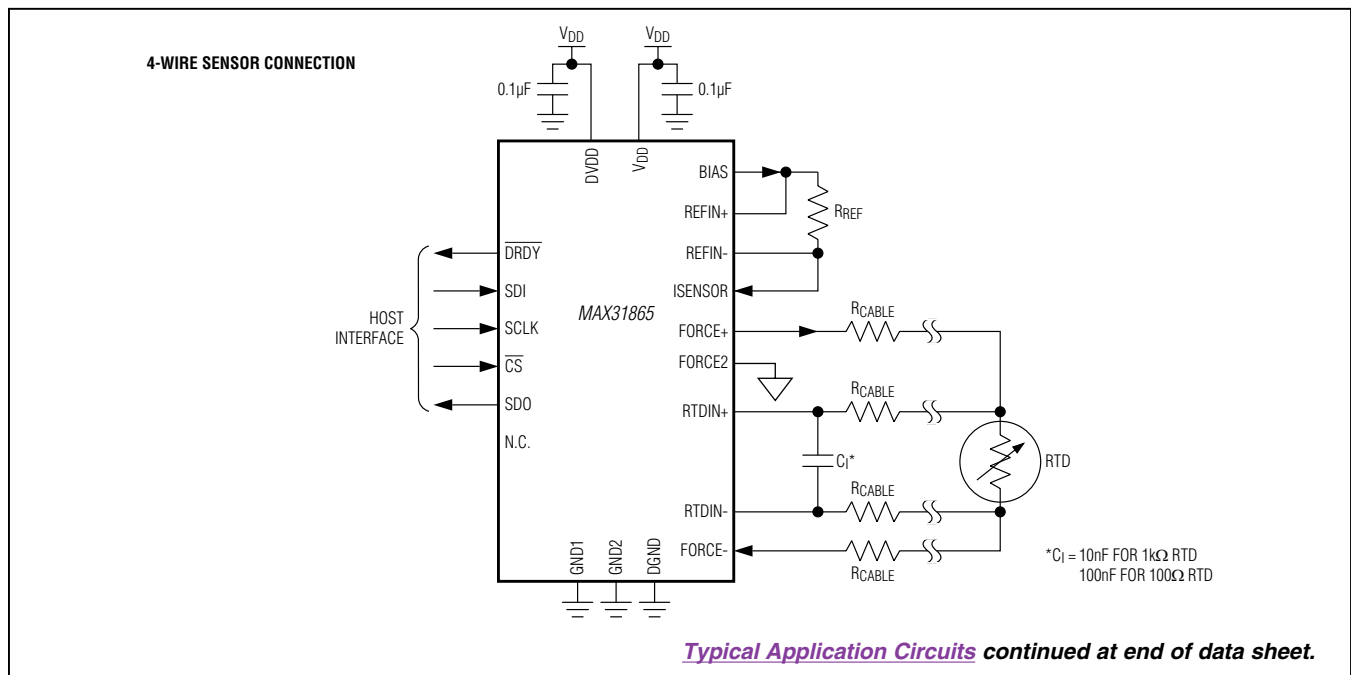

### Absolute Maximum Ratings

Voltage Range on V<sub>DD</sub> Relative to GND1.....-0.3V to +4.0V  
 Voltage Range on BIAS, REFIN+,  
 REFIN-, ISENSOR..... -0.3V to (V<sub>DD</sub> + 0.3V)  
 Voltage Range on FORCE+, FORCE2,  
 FORCE-, RTDIN+, RTDIN- Relative to GND1 .... -50V to +50V  
 Voltage Range on DVDD Relative to DGND.....-0.3V to +4.0V  
 Voltage Range on All Digital Pins  
 Relative to DGND ..... -0.3V to (V<sub>DVDD</sub> + 0.3V)

Continuous Power Dissipation (T<sub>A</sub> = +70°C)  
 TQFN (derate 34.5mW/°C above +70°C).....2758.6mW  
 SSOP (derate 11.9mW/°C above +70° C).....952.4mW  
 ESD Protection (all pins, Human Body Model).....±2kV  
 Operating Temperature Range.....-40°C to +125°C  
 Junction Temperature .....+150°C  
 Storage Temperature Range.....-65°C to +150°C  
 Soldering Temperature (reflow) .....+260°C  
 Lead Temperature (soldering, 10s) .....+300°C

*Stresses beyond those listed under “Absolute Maximum Ratings” may cause permanent damage to the device. These are stress ratings only, and functional operation of the device at these or any other conditions beyond those indicated in the operational sections of the specifications is not implied. Exposure to absolute maximum rating conditions for extended periods may affect device reliability.*

### Package Thermal Characteristics (Note 1)

TQFN

Junction-to-Ambient Thermal Resistance (θ<sub>JA</sub>) .....29°C/W  
 Junction-to-Case Thermal Resistance (θ<sub>JC</sub>).....2°C/W

SSOP

Junction-to-Ambient Thermal Resistance (θ<sub>JA</sub>) .....84°C/W  
 Junction-to-Case Thermal Resistance (θ<sub>JC</sub>).....32°C/W

**Note 1:** Package thermal resistances were obtained using the method described in JEDEC specification JESD51-7, using a four-layer board. For detailed information on package thermal considerations, refer to [www.maximintegrated.com/thermal-tutorial](http://www.maximintegrated.com/thermal-tutorial).

### Recommended DC Operating Conditions

(T<sub>A</sub> = -40°C to +125°C, unless otherwise noted.) (Notes 2 and 3)

PARAMETER	SYMBOL	CONDITIONS	MIN	TYP	MAX	UNITS
V <sub>DD</sub>	V <sub>DD</sub>		3.0	3.3	3.6	V
DVDD	V <sub>DVDD</sub>		3.0	3.3	3.6	V
Input Logic 0	V <sub>IL</sub>	$\overline{CS}$ , SDI, SCLK	-0.3		0.3 x V <sub>DVDD</sub>	V
Input Logic 1	V <sub>IH</sub>	$\overline{CS}$ , SDI, SCLK	0.7 x V <sub>DVDD</sub>		V <sub>DVDD</sub> + 0.3	V
Analog Voltages (FORCE+, FORCE2, FORCE-, RTDIN+, RTDIN-)		Normal conversion results	0		V <sub>BIAS</sub>	V
Reference Resistor	R <sub>REF</sub>		350		10k	Ω
Cable Resistance	R <sub>CABLE</sub>	Per lead	0		50	Ω

### Electrical Characteristics

(3.0V ≤ V<sub>DD</sub> ≤ 3.6V, T<sub>A</sub> = -40°C to +125°C, unless otherwise noted. Typical values are T<sub>A</sub> = +25°C, V<sub>DD</sub> = V<sub>DVDD</sub> = 3.3V.) (Notes 2 and 3)

PARAMETER	SYMBOL	CONDITIONS	MIN	TYP	MAX	UNITS
ADC Resolution		No missing codes		15		Bits
ADC Full-Scale Input Voltage (RTDIN+ - RTDIN-)				REFIN+ - REFIN-		V

### Electrical Characteristics (continued)

( $3.0V \leq V_{DD} \leq 3.6V$ ,  $T_A = -40^\circ\text{C}$  to  $+125^\circ\text{C}$ , unless otherwise noted. Typical values are  $T_A = +25^\circ\text{C}$ ,  $V_{DD} = V_{DVDD} = 3.3V$ .) (Notes 2 and 3)

PARAMETER	SYMBOL	CONDITIONS	MIN	TYP	MAX	UNITS
ADC Common-Mode Input Range			0		$V_{BIAS}$	V
Input Leakage Current		RTDIN+, RTDIN-, $0^\circ\text{C}$ to $+70^\circ\text{C}$ , on-state		2		nA
		RTDIN+, RTDIN-, $-40^\circ\text{C}$ to $+85^\circ\text{C}$ , on-state		5		
		RTDIN+, RTDIN-, $-40^\circ\text{C}$ to $100^\circ\text{C}$ , on-state		14		
Bias Voltage	$V_{BIAS}$		1.95	2.00	2.06	V
Bias Voltage Output Current	$I_{OUT}$		0.2		5.75	mA
Bias Voltage Load Regulation		$I_{OUT} \leq 5.75\text{mA}$		30		mV/mA
Bias Voltage Startup Time		(Note 4)			10	ms
ADC Full-Scale Error				$\pm 1$		LSB
ADC Integral Nonlinearity		Differential Input, endpoint fit, $0.3 \times V_{BIAS} \leq V_{REF} \leq V_{BIAS}$		$\pm 1$		LSB
ADC Offset Error			-3		+3	LSB
Noise (over Nyquist Bandwidth)		Input referred		150		$\mu\text{V RMS}$
Common-Mode Rejection				90		dB
50/60Hz Noise Rejection		Fundamental and harmonics		82		dB
Temperature Conversion Time (Note 5)	$t_{CONV}$	Continuous conversion (60Hz notch)		16.7	17.6	ms
		Single conversion (60Hz notch)		52	55	
		Single conversion (50Hz notch)		62.5	66	
		Continuous conversion (50Hz notch)		20	21	
Automatic Fault Detection Cycle Time		From $\overline{CS}$ high to cycle complete		550	600	$\mu\text{s}$
Power-Supply Rejection				1		LSB/V
Power-Supply Current (Note 6)	$I_{DD}$ Shutdown	Bias off, ADC off		1.5	3	mA
	$I_{DD}$	Bias on, active conversion		2	3.5	mA
Power-On Reset Voltage Threshold			2	2.27		V
Power-On Reset Voltage Hysteresis				120		mV
Input Capacitance	$C_{IN}$	Logic inputs		6		pF
Input Leakage Current	$I_L$	Logic inputs	-1		+1	$\mu\text{A}$
Output High Voltage	$V_{OH}$	$I_{OUT} = -1.6\text{mA}$	$V_{DVDD} - 0.4$			V
Output Low Voltage	$V_{OL}$	$I_{OUT} = 1.6\text{mA}$			0.4	V

## AC Electrical Characteristics: SPI Interface

( $3.0V \leq V_{DD} \leq 3.6V$ ,  $T_A = -40^\circ\text{C}$  to  $+125^\circ\text{C}$ , unless otherwise noted. Typical values are  $T_A = +25^\circ\text{C}$ ,  $V_{DD} = V_{DVDD} = 3.3V$ .) (Notes 3 and 7) (Figure 1 and Figure 2)

PARAMETER	SYMBOL	CONDITIONS	MIN	TYP	MAX	UNITS
Data to SCLK Setup	$t_{DC}$	(Notes 8, 9)	35			ns
SCLK to Data Hold	$t_{CDH}$	(Notes 8, 9)	35			ns
SCLK to Data Valid	$t_{CDD}$	(Notes 8, 9, 10)			80	ns
SCLK Low Time	$t_{CL}$	(Note 9)	100			ns
SCLK High Time	$t_{CH}$	(Note 9)	100			ns
SCLK Frequency	$t_{CLK}$	(Note 9)	DC		5.0	MHz
SCLK Rise and Fall	$t_R, t_F$	(Note 9)			200	ns
$\overline{CS}$ to SCLK Setup	$t_{CC}$	(Note 9)	400			ns
SCLK to $\overline{CS}$ Hold	$t_{CCH}$	(Note 9)	100			ns
$\overline{CS}$ Inactive Time	$t_{CWH}$	(Note 9)	400			ns
$\overline{CS}$ to Output High-Z	$t_{CDZ}$	(Notes 8, 9)			40	ns
Address 01h or 02h Decoded to $\overline{DRDY}$ High	$t_{DRDYH}$	After RTD register read access (Note 9)		50		ns

**Note 2:** All voltages are referenced to ground when common. Currents entering the IC are specified positive.

**Note 3:** Limits are 100% production tested at  $T_A = +25^\circ\text{C}$  and/or  $T_A = +85^\circ\text{C}$ . Limits over the operating temperature range and relevant supply voltage range are guaranteed by design and characterization. Typical values are not guaranteed.

**Note 4:** For 15-bit settling, a wait of at least 10.5 time constants of the input RC network is required. Max startup time is calculated with a  $10\text{k}\Omega$  reference resistor and a  $0.1\mu\text{F}$  capacitor across the RTD inputs.

**Note 5:** The first conversion after enabling continuous conversion mode takes a time equal to the single conversion time for the respective notch frequency.

**Note 6:** Specified with no load on the bias pin as the sum of analog and digital currents. No active communication. If the RTD input voltage is greater than the input reference voltage, then an additional  $400\mu\text{A}$   $I_{DD}$  can be expected.

**Note 7:** All timing specifications are guaranteed by design.

**Note 8:** Measured at  $V_{IH} = 0.7V \times V_{DVDD}$  or  $V_{IL} = 0.3 \times V_{DVDD}$  and 10ms maximum rise and fall times.

**Note 9:** Measured with 50pF load.

**Note 10:** Measured at  $V_{OH} = 0.7 \times V_{DVDD}$  or  $V_{OL} = 0.3 \times V_{DVDD}$ . Measured from the 50% point of SCLK to the  $V_{OH}$  minimum of SDO.

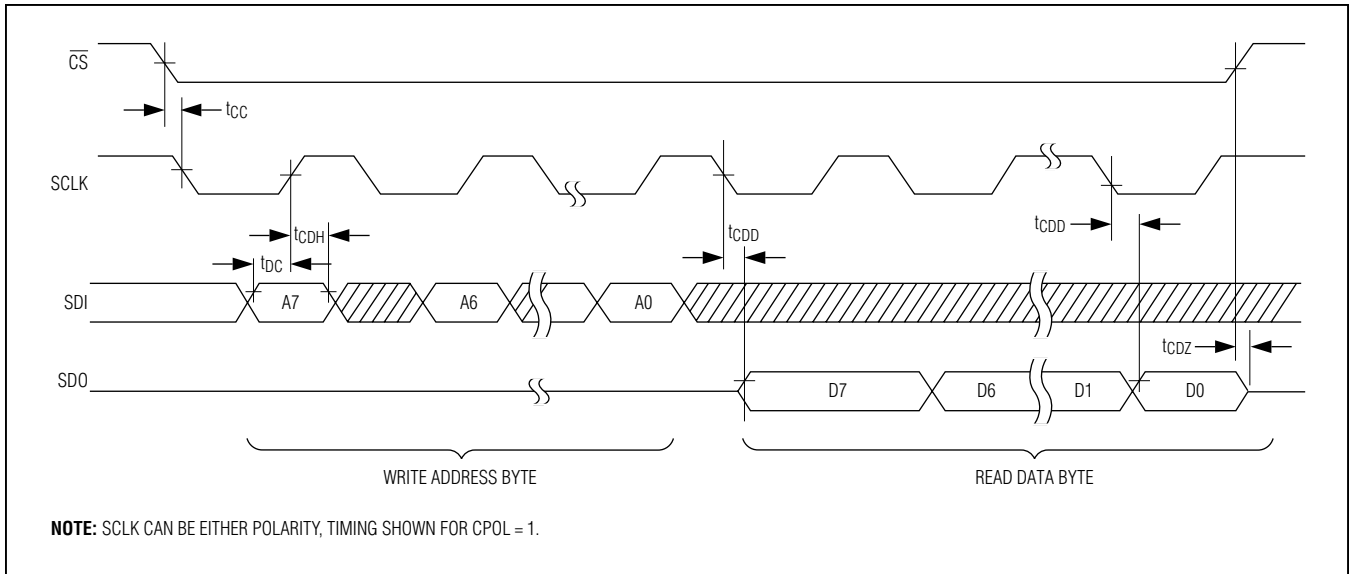

Figure 1. Timing Diagram: SPI Read Data Transfer

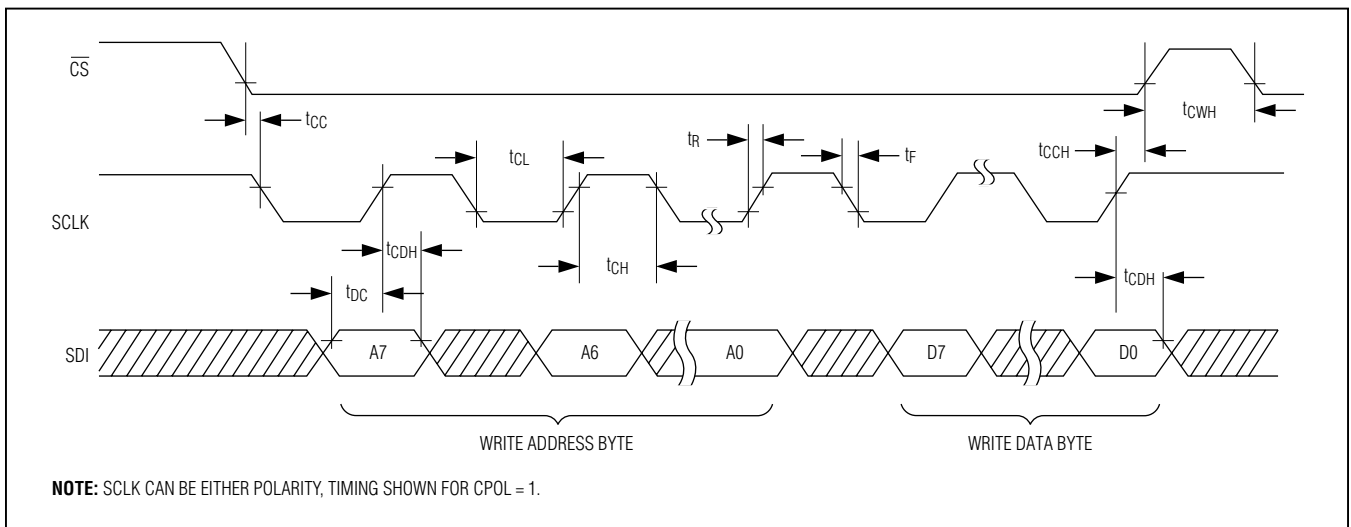
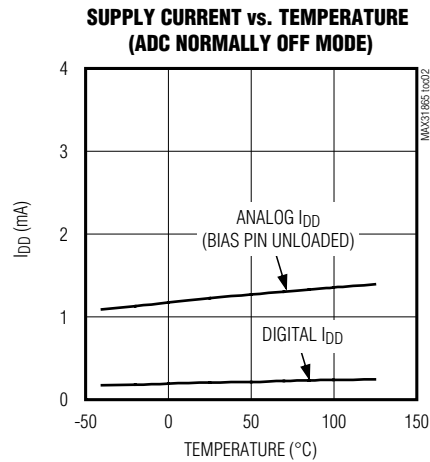
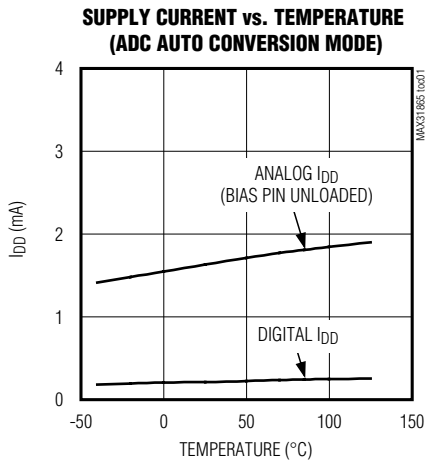

Figure 2. Timing Diagram: SPI Write Data Transfer

Typical Operating Characteristics

( $V_{DD} = V_{DVDD} = 3.3V$ ,  $T_A = +25^\circ C$ , unless otherwise noted.)



**LEAKAGE CURRENT PER PIN vs. TEMPERATURE (1 VOLT APPLIED TO FORCE+, FORCE2, RTDIN+, RTDIN- PINS)**

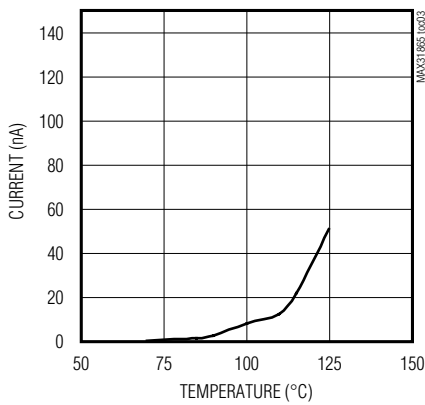

**SINC FILTER OPERATION INPUT FREQUENCY vs. NOISE RESPONSE**

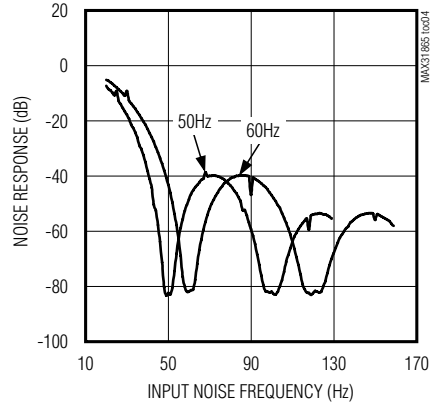

**ADC CONVERSION ERROR vs. RTD RESISTANCE (4kΩ RREF, 4-WIRE CONNECTION)**

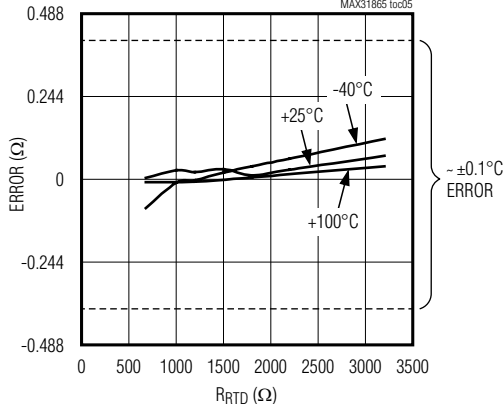

**ADC CONVERSION ERROR vs. RTD RESISTANCE (400Ω RREF, 4-WIRE CONNECTION)**

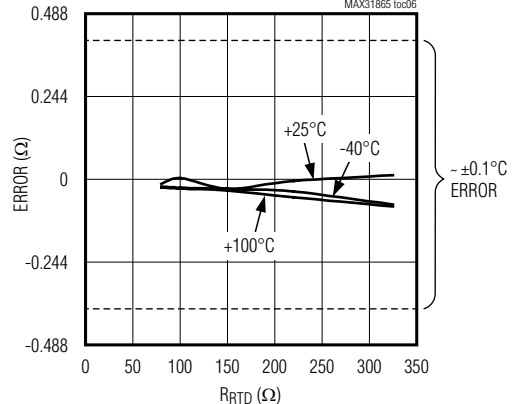

Pin Configurations

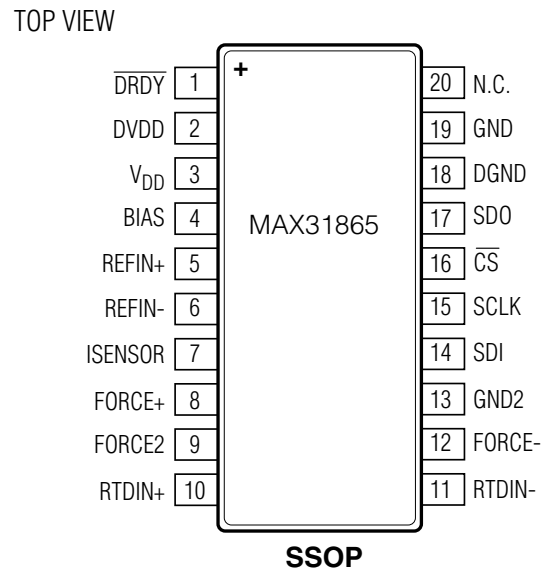
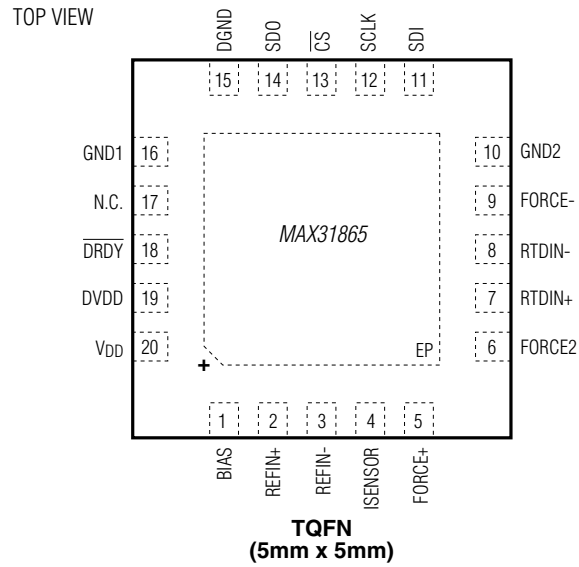

## Pin Description

PIN		NAME	FUNCTION
TQFN	SSOP		
1	4	BIAS	Bias Voltage Output ( $V_{BIAS}$ )
2	5	REFIN+	Positive Reference Voltage Input. Connect to BIAS. Connect the reference resistor between REFIN+ and REFIN-.
3	6	REFIN-	Negative Reference Voltage Input. Connect the reference resistor between REFIN+ and REFIN-.
4	7	ISENSOR	Low Side of $R_{REF}$ . Connect to REFIN-.
5	8	FORCE+	High-Side RTD Drive. Connect to FORCE2 when using the 3-wire connection configuration. Protected to $\pm 45V$ .
6	9	FORCE2	Positive Input Used in 3-Wire Only. When in the 3-wire connection configuration, connect to FORCE+. When in the 2-wire or 4-wire connection configuration, connect to ground. Protected to $\pm 45V$ .
7	10	RTDIN+	Positive RTD Input. Protected to $\pm 45V$ .
8	11	RTDIN-	Negative RTD Input. Protected to $\pm 45V$ .
9	12	FORCE-	Low-Side RTD Return. Protected to $\pm 45V$ .
10	13	GND2	Analog Ground. Connect to GND1.
11	14	SDI	Serial-Data Input
12	15	SCLK	Serial-Data Clock Input
13	16	$\overline{CS}$	Active-Low Chip Select. Set $\overline{CS}$ low to enable the serial interface.
14	17	SDO	Serial-Data Output
15	18	DGND	Digital Ground
16	19	GND1	Analog Ground. Connect to GND2.
17	20	N.C.	Do Not Connect
18	1	$\overline{DRDY}$	Active-Low, Push-Pull, Data-Ready Output. $\overline{DRDY}$ goes low when a new conversion result is available in the data register. When a read operation of an RTD resistance data register occurs, $\overline{DRDY}$ returns high.
19	2	DVDD	Digital Supply Voltage Input. Connect to a 3.3V power supply. Bypass to DGND with a 0.1 $\mu$ F bypass capacitor.
20	3	$V_{DD}$	Analog Supply Voltage Input. Connect to a 3.3V power supply. Bypass to GND1 with a 0.1 $\mu$ F bypass capacitor.
—	—	EP	Exposed Pad (Bottom Side of Package). Connect to GND1. Applies to TQFN package only.

Block Diagram

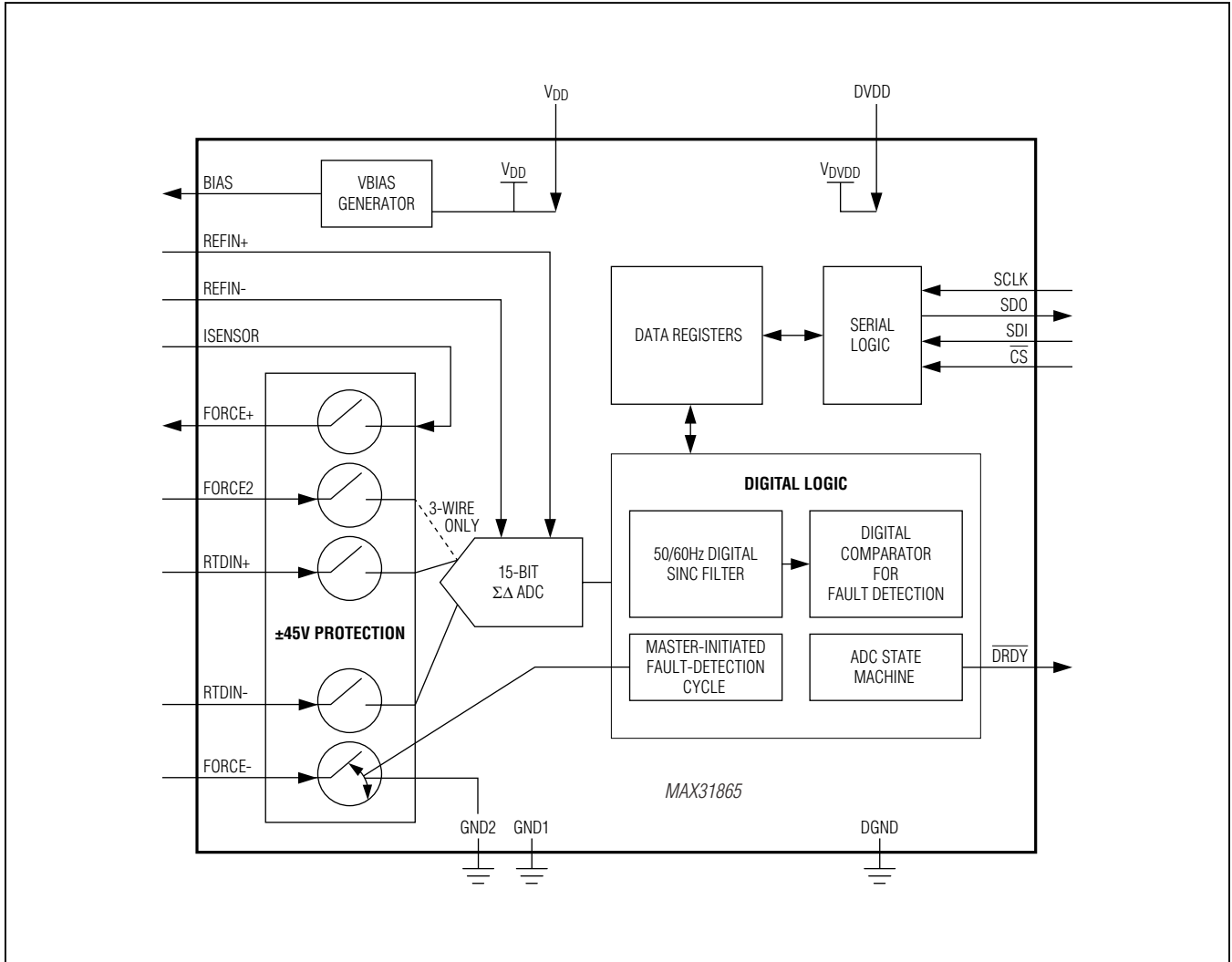

## Detailed Description

The MAX31865 is a sophisticated RTD-to-digital converter with a built-in 15-bit analog-to-digital converter (ADC), input protection, a digital controller, an SPI-compatible interface, and associated control logic. The signal conditioning circuitry is optimized to work with PT100 through PT1000 RTDs. Thermistors are also supported.

## Temperature Conversion

Resistance temperature detectors (RTDs) are sensors whose resistance varies with temperature. Platinum is the most common, most accurate wire material; platinum RTDs are referred to as PT-RTDs. Nickel, copper, and other metals may also be used to make RTDs. Characteristics of platinum RTDs include a wide temperature range (to over +800°C), excellent accuracy and repeatability, and reasonable linearity.

For PT-RTDs, the most common values for nominal resistance at 0°C are 100Ω and 1kΩ, though other values are available. The average slope between 0°C and +100°C is called alpha ( $\alpha$ ). This value depends on the impurities and their concentrations in the platinum. The two most widely used values for alpha are 0.00385 and 0.00392, corresponding to the IEC 751 (PT100) and SAMA standards.

The resistance vs. temperature curve is reasonably linear, but has some curvature, as described by the Callendar-Van Dusen equation:

$$R(T) = R_0(1 + aT + bT^2 + c(T - 100)T^3)$$

where:

T = temperature (°C)

R(T) = resistance at T

R<sub>0</sub> = resistance at T = 0°C

IEC 751 specifies  $\alpha = 0.00385055$  and the following Callendar-Van Dusen coefficient values:

$$a = 3.90830 \times 10^{-3}$$

$$b = -5.77500 \times 10^{-7}$$

$$c = -4.18301 \times 10^{-12} \text{ for } -200^\circ\text{C} \leq T \leq 0^\circ\text{C}, \text{ 0 for } 0^\circ\text{C} \leq T \leq +850^\circ\text{C}$$

Figure 3 shows the curve of resistance vs. temperature for a PT100 RTD along with a straight-line approximation based on the slope between 0°C and +100°C.

To measure the RTD's resistance, connect a reference resistor (R<sub>REF</sub>) and RTD in series and apply the bias voltage to the top of R<sub>REF</sub> as shown in the [Typical](#)

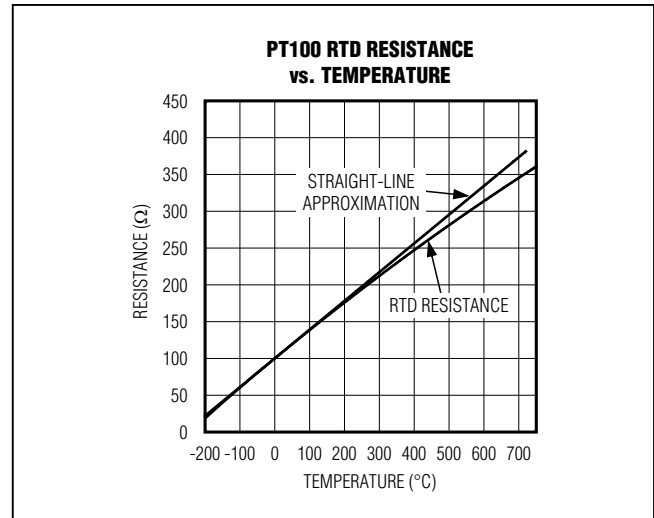

Figure 3. PT100 RTD resistance vs. temperature.

**Application Circuits.** The reference resistor current also flows through the RTD. The voltage across the reference resistor is the reference voltage for the ADC. The voltage across the RTD is applied to the ADC's differential inputs (RTDIN+ and RTDIN-). The ADC therefore produces a digital output that is equal to the ratio of the RTD resistance to the reference resistance. A reference resistor equal to four times the RTD's 0°C resistance is optimum for a platinum RTD. Therefore, a PT100 uses a 400Ω reference resistor, and a PT1000 uses a 4kΩ reference resistor.

A 2-wire connection (see the [Typical Application Circuits](#)) can give acceptable results when the RTD is located close to the MAX31865. Note that, for a PT100, series resistance of 0.4Ω causes an error of approximately 1°C. Therefore, as the cable length increases, the error due to cable resistance can become excessive.

The 4-wire connection eliminates errors due to cable resistance by using separate force and sense leads.

A 3-wire connection is a compromise approach that uses one less conductor than the 4-wire approach. To compensate for the voltage drop across the return wire, the voltage between FORCE+ and RTDIN+ is subtracted from (RTDIN+ - RTDIN-). This is accomplished using the FORCE2 sampling input. If the cable resistances are well-matched, the error due to cable resistance is cancelled. Select 3-wire operation by setting the 3-wire bit in the Configuration register to 1.

### Linearizing Temperature Data

For a temperature range of -100°C to +100°C, a good approximation of temperature can be made by simply using the RTD data as shown below:

$$\text{Temperature (}^\circ\text{C)} \approx (\text{ADC code}/32) - 256$$

This equation gives 0°C error at 0°C, -1.75°C error at -100°C, and -1.4°C error at +100°C (assuming an IEC751 RTD and  $R_{REF}$  equal to four times the 0 °C RTD resistance). For high precision, use the Callendar-Van Dusen equation (in the [Temperature Conversion](#) section) or a lookup table to correct the RTD's predictable nonlinearity.

### Using Thermistors

Other resistive sensors, such as thermistors (NTCs or PTCs) may be used. Select an  $R_{REF}$  that is greater than or equal to the sensor's maximum resistance over the temperature range of interest. The output data is the ratio of the sensor resistance to the reference resistance.

### Analog-to-Digital Converter (ADC)

The ADC has fully differential analog inputs, RTDIN+ and RTDIN-, and fully differential reference inputs, REFIN+ and REFIN-. The output code represents the ratio between the analog input voltage and the reference voltage. A negative input voltage produces an output code of 0. An input voltage greater than the reference voltage produces a full-scale output.

Input noise is attenuated by a third-order digital "sinc" filter. Noise from 50Hz or 60Hz power sources (including harmonics of the ac power's fundamental frequency) is attenuated by 82dB.

### Fault Detection and Input Protection

The MAX31865 detects a variety of faults that can occur with the external RTD and 2-, 3-, or 4-wire cables. Some faults are detected on every conversion, while others are

detected only when a fault detection cycle is requested by the master. During a fault detection cycle the MAX31865 has the ability to disconnect the FORCE- input from its GND2 return path by means of an internal analog switch.

The conditions that generate a fault are listed below, see [Figure 4](#) for a fault detection flowchart.

- Detected at any point in time
  - Overvoltage ( $> V_{DD}$ ) or undervoltage ( $< GND1$ ) condition on FORCE+, FORCE2, RTDIN+, RTDIN-, or FORCE- pins
- Detected every ADC conversion
  - Greater than or equal to threshold high conversion result
  - Less than or equal to threshold low conversion result
- Detected on demand by initiating a Fault Detection Cycle (Configuration Register bits (D[3:2])
  - $V_{REFIN-} > 0.85 \times V_{BIAS}$
  - $V_{REFIN-} < 0.85 \times V_{BIAS}$  when FORCE- input switch is open
  - $V_{RTDIN-} < 0.85 \times V_{BIAS}$  when FORCE- input switch is open

FORCE+, FORCE2, FORCE-, RTDIN+, and RTDIN- are protected against input voltages up to  $\pm 45V$ . Signals applied to these pins are gated by analog switches that open when the applied voltage is typically greater than  $V_{DD} + 100mV$  or less than  $GND1 - 400mV$ . Note that when a voltage fault occurs, the protection circuits may allow approximately 350 $\mu A$  of current flow. This fault-induced leakage current does not cause any damage to the MAX31865.

When an overvoltage or undervoltage condition is detected, bit D2 of the Fault Status register is set and the ADC halts conversion updates until the fault is no longer detected, at which point conversions resume.

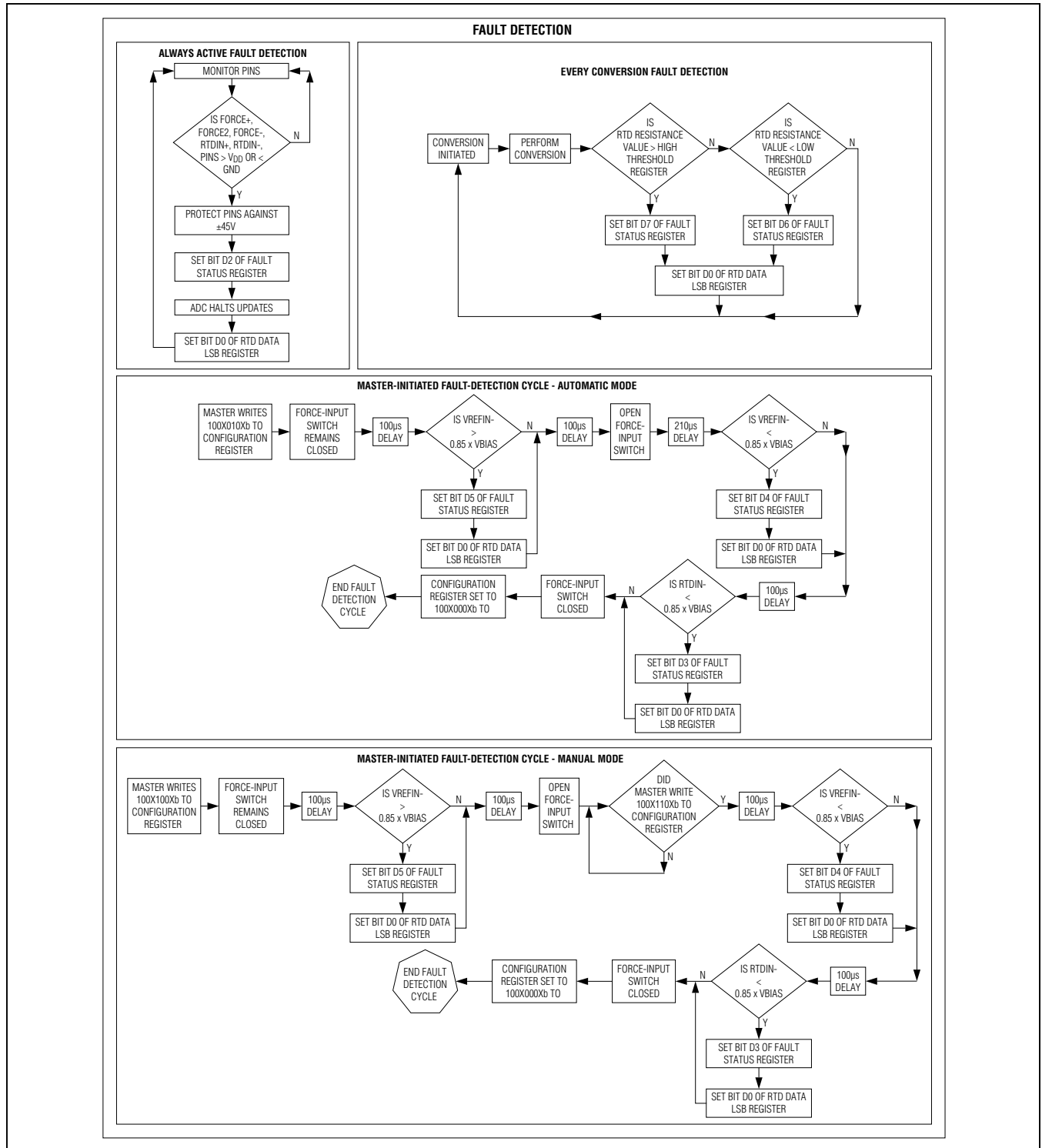

Figure 4. Fault Detection Flowcharts

**Internal Registers**

Communication is through eight 8-bit registers that contain conversion, status, and configuration data. All programming is done by selecting the appropriate address of the desired register location. [Table 1](#) illustrates the addresses for the registers.

The registers are accessed using the 0Xh addresses for reads and the 8Xh addresses for writes. Data is read from or written to the registers MSB first.

**Configuration Register (00h)**

The configuration register selects the conversion mode (automatic or triggered by the 1-shot command), enables and disables BIAS pin output voltage  $V_{BIAS}$ , initiates 1-shot conversions, selects the RTD connection (either 3-wire or 2-wire/4-wire), initiates a full fault detection cycle, clears the Fault Status register, and selects the filter notch frequencies. The effects of the configuration bits are described below.

**BIAS (D7)**

When no conversions are being performed,  $V_{BIAS}$  may be disabled to reduce power dissipation. Write 1 to this bit to enable  $V_{BIAS}$  before beginning a single (1-Shot) conversion. When automatic (continuous) conversion mode is selected,  $V_{BIAS}$  remains on continuously.

**Conversion Mode (D6)**

Write 1 to this bit to select automatic conversion mode, in which conversions occur continuously at a 50/60Hz rate. Write 0 to this bit to exit automatic conversion mode and enter the “Normally Off” mode. 1-shot conversions may be initiated from this mode.

**1-Shot (D5)**

When the conversion mode is set to “Normally Off”, write 1 to this bit to start a conversion. This causes a single resistance conversion to take place. The conversion is triggered when  $\overline{CS}$  goes high after writing a 1 to this bit. Note that if a multibyte write is performed, the conversion is triggered when  $\overline{CS}$  goes high at the end of the transaction. If  $V_{BIAS}$  is on (as selected by the Configuration Register), the RTD voltage is sampled when  $\overline{CS}$  goes high and the conversion begins. Note that if  $V_{BIAS}$  is off (to reduce supply current between conversions), any filter capacitors at the RTDIN inputs need to charge before an accurate conversion can be performed. Therefore, enable  $V_{BIAS}$  and wait at least 10.5 time constants of the input RC network plus an additional 1ms before initiating the conversion. Note that a single conversion requires approximately 52ms in 60Hz filter mode or 62.5ms in 50Hz filter mode to complete. 1-Shot is a self-clearing bit.

**Table 1. Register Addresses and POR State**

REGISTER NAME	READ ADDRESS (HEX)	WRITE ADDRESS (HEX)	POR STATE	READ/WRITE
Configuration	00h	80h	00h	R/W
RTD MSBs	01h	—	00h	R
RTD LSBs	02h	—	00h	R
High Fault Threshold MSB	03h	83h	FFh	R/W
High Fault Threshold LSB	04h	84h	FFh	R/W
Low Fault Threshold MSB	05h	85h	00h	R/W
Low Fault Threshold LSB	06h	86h	00h	R/W
Fault Status	07h	—	00h	R

**Table 2. Configuration Register Definition**

D7	D6	D5	D4	D3	D2	D1	D0
$V_{BIAS}$ 1 = ON 0 = OFF	Conversion mode 1 = Auto 0 = Normally off	1-shot 1 = 1-shot (auto-clear)	3-wire 1 = 3-wire RTD 0 = 2-wire or 4-wire	Fault Detection Cycle Control (see Table 3)		Fault Status Clear 1 = Clear (auto-clear)	50/60Hz filter select 1 = 50Hz 0 = 60Hz

**3-Wire (D4)**

Write 1 to this bit when using a 3-wire RTD connection. In this mode the voltage between FORCE+ and RTDIN+ is subtracted from (RTDIN+ - RTDIN-) to compensate for the IR errors caused by using a single wire for the FORCE- and RTDIN- connections. When using 2-wire or 4-wire connections, write 0 to this bit.

**Fault Detection Cycle (D3:D2)**

The master initiated fault detection cycle has two modes of operation, manual and automatic mode timing. If the external RTD interface circuitry includes an input filter with a time constant greater than 100 $\mu$ s, the fault detection cycle timing should be controlled in the manual mode operation. The fault detection cycle checks for three faults by making the following voltage comparisons and setting the associated bits in the Fault Status Register:

- 1) Is the voltage at REFIN- greater than 85% x V<sub>BIAS</sub>? (Fault Status Register bit D5)
- 2) Is the voltage at REFIN- less than 85% x V<sub>BIAS</sub> when FORCE- input switch is open? (Fault Status Register bit D4)
- 3) Is the voltage at RTDIN- less than 85% x V<sub>BIAS</sub> when FORCE- input switch is open? (Fault Status Register bit D3)

**Note:** All voltages are referenced to GND1.

The [Applications Information](#) provides tables for decoding possible causes of set fault status bits.

To enter the automatic fault detection cycle, write 100X010Xb to the Configuration register. The ADC is now in “Normally Off” mode. The automatic fault detection cycle inserts 100 $\mu$ s delays before checking for faults, thereby allowing the external input filter to settle. The

Fault Detect Cycle bits (D[3:2]) self-clear to 00b upon completion.

To enter the manual fault detection cycle, first ensure that V<sub>BIAS</sub> has been on for at least 5 time constants. Next, write 100X100Xb to the Configuration register. The ADC is now in “Normally Off” mode. The MAX31865 checks for faults while the FORCE- input switch is closed, and when the check completes, the FORCE- input switch opens. The Fault Detect Cycle bits (D[3:2]), remain set to 10b. Again, wait at least 5 time constants, and then write 100X110Xb to the Configuration register. The MAX31865 now checks for faults while the FORCE- inputs switch is open; when the check completes, the FORCE- input switch closes and the Fault Detect Cycle bits (D[3:2]) self-clear to 00b. Note that if 1 is written to D5 (1-Shot) and D2 or D3 in a single write, both commands are ignored. If 100X110Xb is set without a prior initiation of the first manual step (setting 100X100Xb), the automatic fault detection mode is run instead.

**Fault Status Clear (D1)**

Write a 1 to this bit while writing 0 to bits D5, D3, and D2 to return all fault status bits (D[7:2]) in the Fault Status Register to 0. Note that bit D2 in the Fault Register, and subsequently bit D0 in the RTD LSB register may be set again immediately after resetting if an over/undervoltage fault persists. The fault status clear bit D1, self-clears to 0.

**50/60Hz (D0)**

This bit selects the notch frequencies for the noise rejection filter. Write 0 to this bit to reject 60Hz and its harmonics; write 1 to this bit to reject 50Hz and its harmonics. **Note:** Do not change the notch frequency while in auto conversion mode.

**Table 3. Fault-Detection Cycle Control Bits**

D3	D2	CONFIGURATION REGISTER WRITE (BINARY)	WRITE ACTION	READ MEANING
0	0	XXXX00XXb	No action	Fault detection finished
0	1	100X010Xb	Fault detection with automatic delay	Automatic fault detection still running
1	0	100X100Xb	Run fault detection with manual delay (cycle 1)	Manual cycle 1 still running; waiting for user to write 11
1	1	100X110Xb	Finish fault detection with manual delay (cycle 2)	Manual cycle 2 still running

X = Don't care

**RTD Resistance Registers (01h–02h)**

Two 8-bit registers, RTD MSBs and RTD LSBs, contain the RTD resistance data. The data format is shown in [Table 4](#). The data format is simply the 15-bit ratio of RTD

resistance to reference resistance. D0 of the RTD LSBs register is a Fault bit that indicates whether any RTD faults have been detected.

**Table 4. RTD Resistance Registers Definition**

REGISTER	RTD MSBS (01h) REGISTER								RTD LSBS (02h) REGISTER							
Bit	D7	D6	D5	D4	D3	D2	D1	D0	D7	D6	D5	D4	D3	D2	D1	D0
RTD Resistance Data	MSB	—	—	—	—	—	—	—	—	—	—	—	—	—	LSB	Fault
Bit Weighting	2 <sup>14</sup>	2 <sup>13</sup>	2 <sup>12</sup>	2 <sup>11</sup>	2 <sup>10</sup>	2 <sup>9</sup>	2 <sup>8</sup>	2 <sup>7</sup>	2 <sup>6</sup>	2 <sup>5</sup>	2 <sup>4</sup>	2 <sup>3</sup>	2 <sup>2</sup>	2 <sup>1</sup>	2 <sup>0</sup>	—
Decimal Value	16384	8192	4096	2048	1024	512	256	128	64	32	16	8	4	2	1	—

**Table 5. RTD Resistance-Data Relationship**

R <sub>RTD</sub> /R <sub>REF</sub>	BINARY		HEX		DECIMAL
	RTD MSBs (01h)	RTD LSBs (02h)	RTD MSBs (01h)	RTD LSBs (02h)	
0.025	0000 0110	0110 0110b	06h	66h	819
0.125	0010 0000	0000 0000b	20h	00h	4096
0.25	0100 0000	0000 0000b	40h	00h	8192
0.50	1000 0000	0000 0000b	80h	00h	16,384
0.75	1100 0000	0000 0000b	C0h	00h	24,576
0.999	1111 1111	1111 1110b	FFh	FEh	32,767

**Note:** D0 (“Fault”) is assumed to be 0.

**Fault Threshold Registers (03h–06h)**

The High Fault Threshold and Low Fault Threshold registers select the trip thresholds for RTD fault detection. The results of RTD conversions are compared with the values in these registers to generate the “Fault” (D[7:6]) bits in the Fault Status register. The RTD Data Registers, High Fault Threshold Registers, and Low Fault Threshold Registers all have the same format.

The RTD High bit in the Fault Status Register is set if the RTD resistance register value is greater than or equal to the value in the High Fault Threshold register. The POR value of the High Fault Threshold register is FFFFh.

The RTD Low bit in the Fault Status Register is set if the RTD resistance value is less than or equal to the value in the Low Fault Threshold register. The POR value of the Low Fault Threshold register is 0000h.

**Fault Status Register (07h)**

The Fault Status register latches any detected fault bits; writing a 1 to the Fault Status Clear bit in the Configuration Register returns all fault status bits to 0.

**Serial Interface**

The MAX31865 supports SPI modes 1 and 3. Four pins are used for SPI-compatible communications: SDO (serial-data out), SDI (serial-data in),  $\overline{CS}$  (chip select), and SCLK (serial clock). SDI and SDO are the serial-data input and output pins for the devices, respectively. The  $\overline{CS}$  input initiates and terminates a data transfer. SCLK synchronizes data movement between the master (microcontroller) and the slave (MAX31865).

The serial clock (SCLK), which is generated by the microcontroller, is active only when  $\overline{CS}$  is low and during address and data transfer to any device on the SPI

**Table 6. Fault Threshold Registers Definition**

REGISTER	HIGH FAULT THRESHOLD MSB (03h) REGISTER								HIGH FAULT THRESHOLD LSB (04h) REGISTER							
	LOW FAULT THRESHOLD MSB (05h) REGISTER								LOW FAULT THRESHOLD LSB (06h) REGISTER							
Bit	D7	D6	D5	D4	D3	D2	D1	D0	D7	D6	D5	D4	D3	D2	D1	D0
RTD Resistance Data	MSB	—	—	—	—	—	—	—	—	—	—	—	—	—	LSB	X
Bit Weighting	2 <sup>14</sup>	2 <sup>13</sup>	2 <sup>12</sup>	2 <sup>11</sup>	2 <sup>10</sup>	2 <sup>9</sup>	2 <sup>8</sup>	2 <sup>7</sup>	2 <sup>6</sup>	2 <sup>5</sup>	2 <sup>4</sup>	2 <sup>3</sup>	2 <sup>2</sup>	2 <sup>1</sup>	2 <sup>0</sup>	—
Decimal Value	16384	8192	4096	2048	1024	512	256	128	64	32	16	8	4	2	1	—

X = Don't care

**Table 7. Fault Status Register Definition**

D7	D6	D5	D4	D3	D2	D1	D0
RTD High Threshold	RTD Low Threshold	REFIN- > 0.85 x V <sub>BIAS</sub>	REFIN- < 0.85 x V <sub>BIAS</sub> (FORCE- open)	RTDIN- < 0.85 x V <sub>BIAS</sub> (FORCE- open)	Overvoltage/ undervoltage fault	x	x

X = Don't care

bus. The inactive clock polarity is programmable in some microcontrollers. The MAX31865 automatically accommodates either clock polarity by sampling SCLK when  $\overline{CS}$  becomes active to determine the polarity of the inactive clock. Input data (SDI) is latched on the internal strobe edge and output data (SDO) is shifted out on the shift edge (see [Table 8](#) and [Figure 5](#)). There is one clock for each bit transferred. Address and data bits are transferred in groups of eight, MSB first.

**Address and Data Bytes**

Address and data bytes are shifted MSB-first into the serial-data input (SDI) and out of the serial-data output (SDO). Any transfer requires the address of the byte to specify a write or a read, followed by one or more bytes of data. Data is transferred out of the SDO for a read opera-

tion and into the SDI for a write operation. The address byte is always the first byte transferred after  $\overline{CS}$  is driven low. The MSB (A7) of this byte determines whether the following byte is written or read. If A7 is 0, one or more byte reads follow the address byte. If A7 is 1, one or more byte writes follow the address byte.

For a single-byte transfer, 1 byte is read or written and then  $\overline{CS}$  is driven high (see [Figure 6](#) and [Figure 7](#)). For a multiple-byte transfer, multiple bytes can be read or written after the address has been written (see [Figure 8](#)). The address continues to increment through all memory locations as long as  $\overline{CS}$  remains low. If data continues to be clocked in or out, the address loops from 7Fh/FFh to 00h/80h. Invalid memory addresses report an FFh value. Attempting to write to a read-only register results in no change to that register’s contents.

**Table 8. Function Table**

MODE	$\overline{CS}$	SCLK	SDI	SDO
Disable Reset	High	Input disabled	Input disabled	High impedance
Write	Low	CPOL = 1*, SCLK rising	Data bit latch	High impedance
		CPOL = 0, SCLK falling		
Read	Low	CPOL = 1, SCLK falling	X	Next data bit shift**
		CPOL = 0, SCLK rising		

**Note:** CPHA bit polarity must be set to 1.

\*CPOL is the clock polarity bit that is set in the control register of the microcontroller.

\*\*SDO remains at high impedance until 8 bits of data are ready to be shifted out during a read.

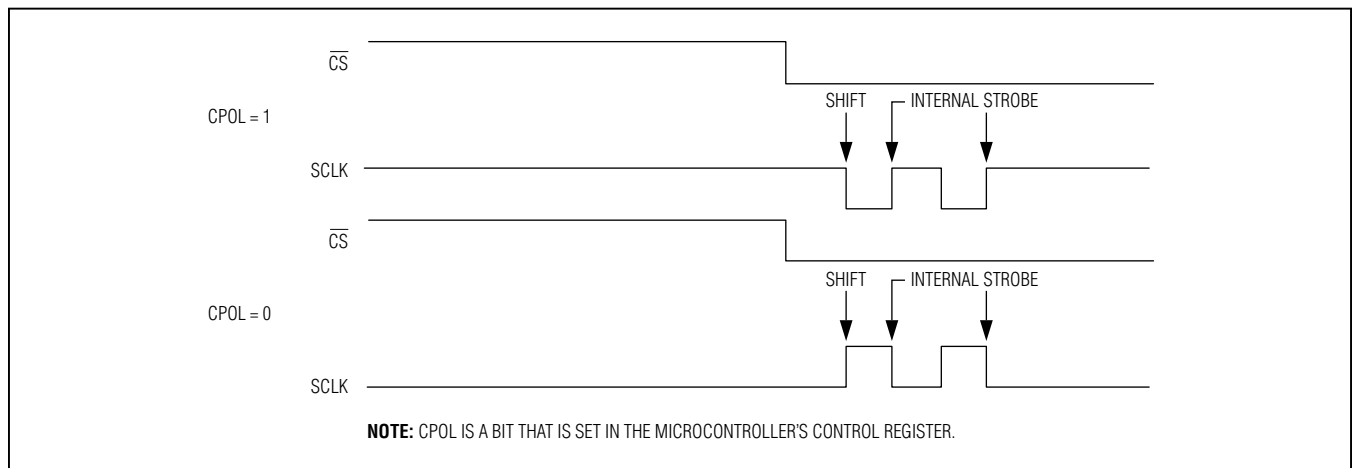

Figure 5. Serial Clock as a Function of Microcontroller Clock Polarity (CPOL)

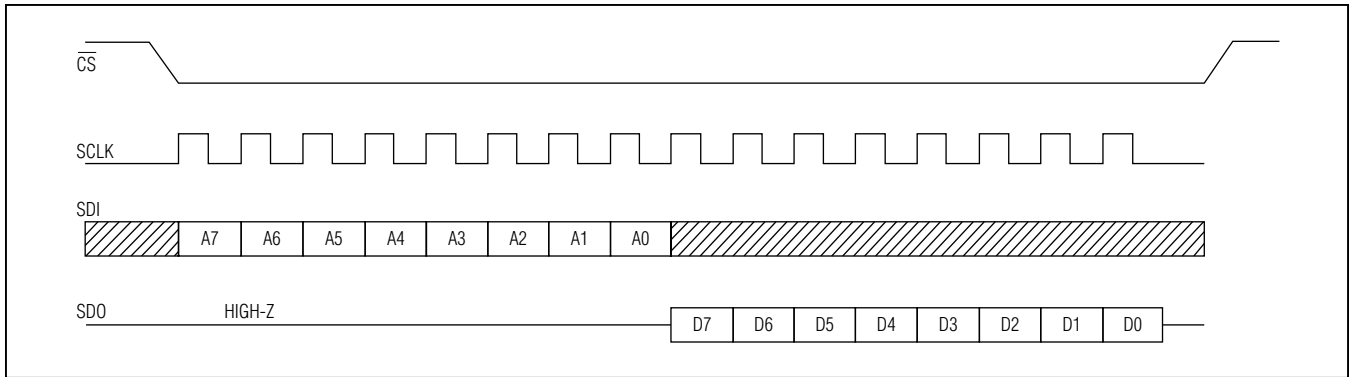

Figure 6. SPI Single-Byte Read

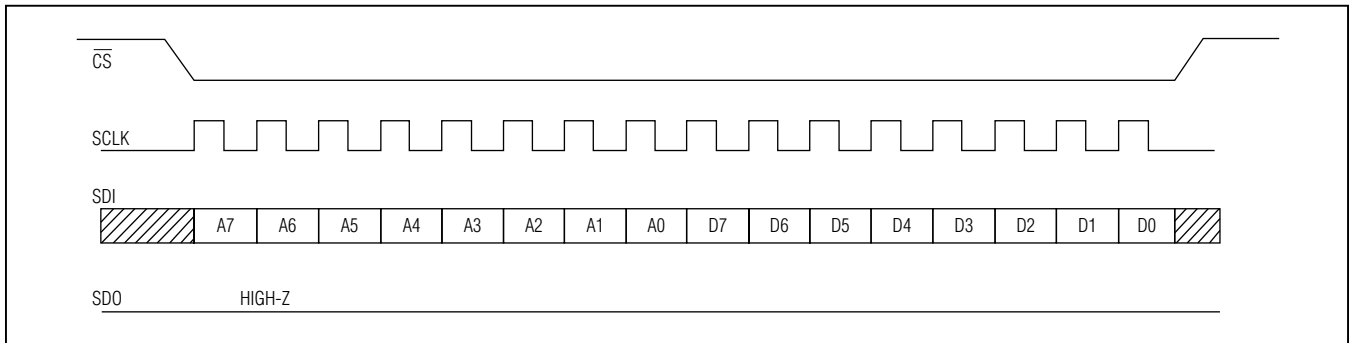

Figure 7. SPI Single-Byte Write

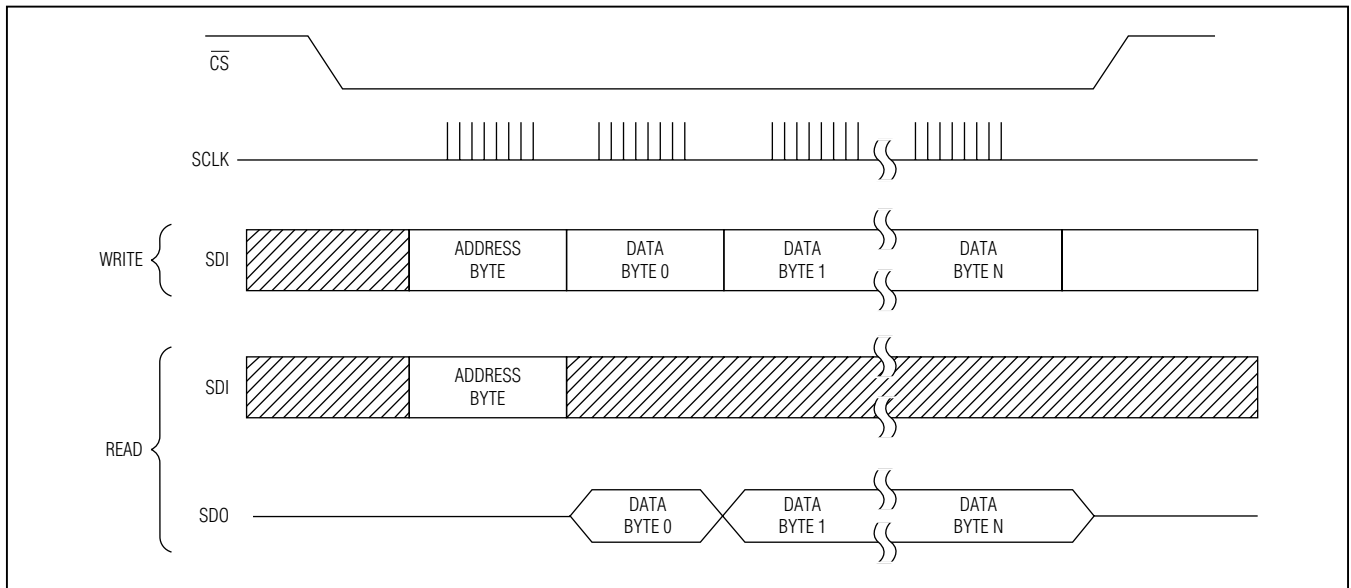

Figure 8. SPI Multibyte Transfer

**DRDY**

The  $\overline{\text{DRDY}}$  output goes low when a new conversion result is available in the RTD Data Registers. When a read-operation of the RTD Data Registers completes,  $\overline{\text{DRDY}}$  returns high.

**Applications Information**

For operation in noisy environments, a filter capacitor may be placed across the RTDIN+ and RTDIN- inputs. After an overvoltage or undervoltage fault, after a fault detection cycle, or after enabling  $V_{\text{BIAS}}$ , always allow for the settling time of the input filter before restarting the ADC. A delay time of at least five time constants plus an

additional 1ms (for the protection devices to stabilize) is recommended to achieve specified accuracy.

**Converting RTD Data Register Values to Temperature**

The ratiometric ADC conversion results found in the RTD Data Registers can be converted to temperature with a few calculations.

First, the Resistance of the RTD needs to be determined with the following equation:

$$R_{\text{RTD}} = (\text{ADC Code} \times R_{\text{REF}}) / 2^{15}$$

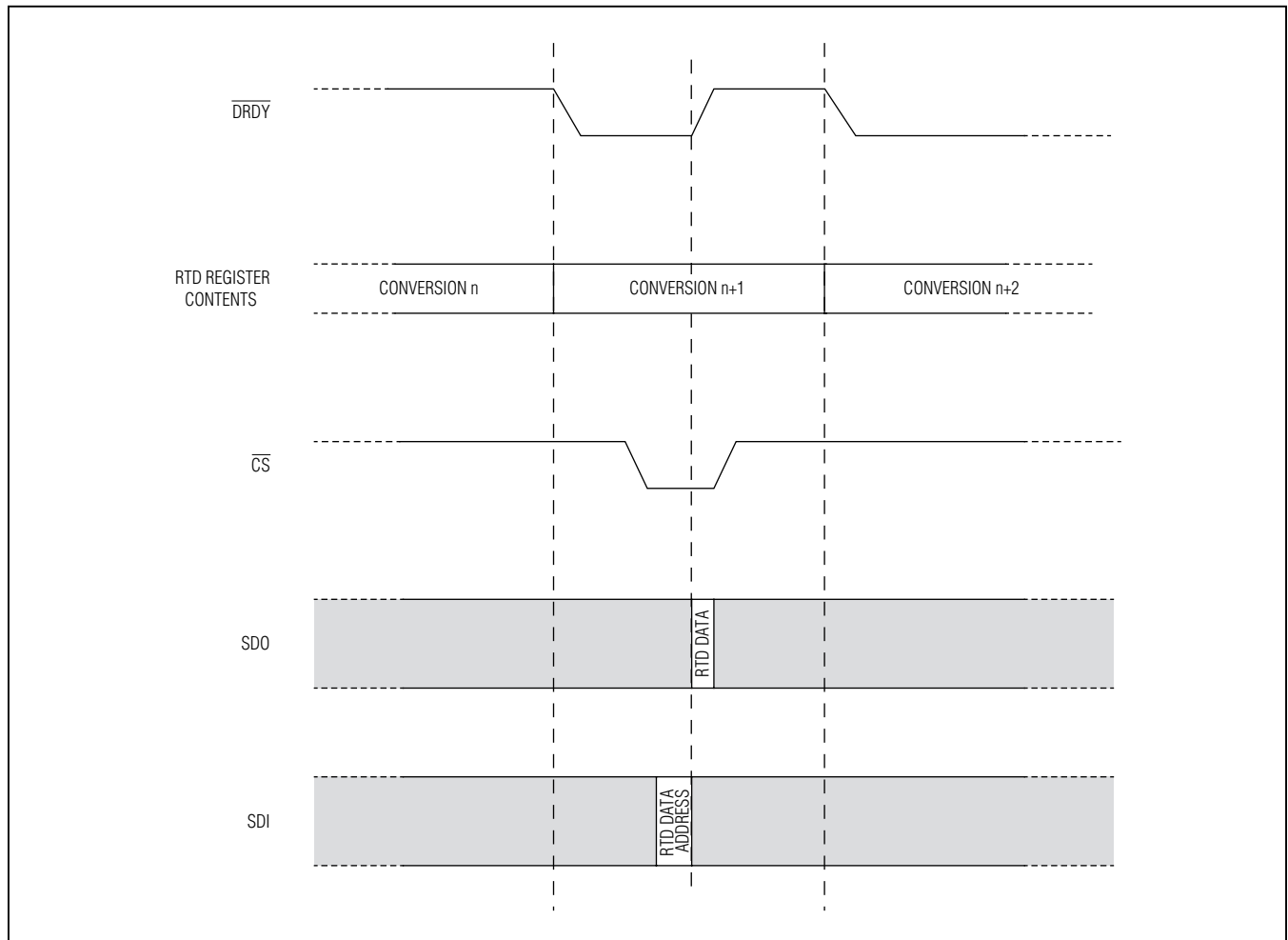

Figure 9.  $\overline{\text{DRDY}}$  Operation

ADC Code = 15-bit ADC results from RTD Data registers (01h–02h)

$R_{REF}$  = Resistance of the reference resistor

Once the resistance of the RTD is known, the well-defined resistive properties of the selected RTD can be used to

determine temperature by either calculations or lookup tables.

In the typical case of a PT100 RTD with a 400 $\Omega$  high precision low drift reference resistor, [Table 9](#) shows examples of temperature and resistance values with the corresponding ADC code results.

**Table 9. Temperature Example for PT100 with 400 $\Omega$   $R_{REF}$**

TEMPERATURE (°C)	RTD RESISTANCE ( $\Omega$ )	RTD DATA REG (01h–02h) (hex)	ADC CODE (dec)	ADC CODE/32-256 (°C)
-200	18.52	0BDAh	1517	-208.59
-175	29.22	12B4h	2394	-181.19
-150	39.72	196Ch	3254	-154.31
-125	50.06	200Ah	4101	-127.84
-100	60.26	2690h	4936	-101.75
-75	70.33	2D04h	5762	-75.94
-50	80.31	3366h	6579	-50.41
-40	84.27	35EEh	6903	-40.28
-30	88.22	3876h	7227	-30.16
-20	92.16	3AFCh	7550	-20.06
-10	96.09	3D7Eh	7871	-10.03
0	100.00	4000h	8192	0.00
10	103.90	4280h	8512	10.00
20	107.79	44FCh	8830	19.94
30	111.67	4778h	9148	29.88
40	115.54	49F2h	9465	39.78
50	119.40	4C6Ah	9781	49.66
60	123.24	4EE0h	10096	59.50
70	127.08	5154h	10410	69.31
80	130.90	53C6h	10723	79.09
90	134.71	5636h	11035	88.84
100	138.51	58A4h	11346	98.56
110	142.29	5B12h	11657	108.28
120	146.07	5D7Ch	11966	117.94
130	149.83	5FE4h	12274	127.56
140	153.58	624Ch	12582	137.19
150	157.33	64B0h	12888	146.75
160	161.05	6714h	13194	156.31
170	164.77	6974h	13498	165.81
180	168.48	6BD4h	13802	175.31
190	172.17	6E30h	14104	184.75
200	175.86	708Ch	14406	194.19
225	185.01	7668h	15156	217.63
250	194.10	7C3Ah	15901	240.91

**Table 9. Temperature Example for PT100 with 400Ω R<sub>REF</sub> (continued)**

TEMPERATURE (°C)	RTD RESISTANCE (Ω)	RTD DATA REG (01h–02h) (hex)	ADC CODE (dec)	ADC CODE/32-256 (°C)
275	203.11	81FEh	16639	263.97
300	212.05	87B6h	17371	286.84
325	220.92	8D64h	18098	309.56
350	229.72	9304h	18818	332.06
375	238.44	989Ah	19533	354.41
400	247.09	9E24h	20242	376.56
425	255.67	A3A2h	20945	398.53
450	264.18	A914h	21642	420.31
475	272.61	AE7Ah	22333	441.91
500	280.98	B3D4h	23018	463.31
525	289.27	B922h	23697	484.53
550	297.49	BE64h	24370	505.56

### Detecting RTDIN+ Cable Faults

In the 3- and 4-wire RTD connection configuration, a broken or disconnected RTDIN+ cable results in an unbiased ADC+ input into the MAX31865. This causes unpredictable ADC conversion results, which can be influenced by PCB layout, external circuit noise, and ambient temperature. This cable fault condition can go undetected depending upon the values set in the fault threshold registers. If this condition is of interest, add a 10MΩ resistor from the RTDIN+ pin to the BIAS pin. Doing so results in a full-scale RTD resistance measurement if the RTDIN+ lead is broken or disconnected.

### Decoding RTD and Cable Fault Conditions

An open RTD element or a short across the RTD element are detected on every conversion based on the resistance data. An open RTD element results in a full-scale reading. Set the threshold for open RTD element detection using the High Fault Threshold registers. If the conversion result is greater than or equal to the threshold value, the RTD High bit in the Fault Status register is set at the end of the

conversion. An open RTD element can also be detected on demand by testing for  $V_{REFIN-} > 0.85 \times V_{BIAS}$ . A shorted RTD element produces a conversion result near zero. Set the threshold for shorted RTD detection in the Low Fault Threshold registers.

[Table 10](#), [Table 11](#), and [Table 12](#) summarize how RTD and cable faults are detected for 2-, 3-, and 4-wire setups and provide a description for the most common cause.

Fault Status bits are latched until the Fault Clear bit in the Configuration register is set. This allows intermittent faults to be captured.

### Power-Supply Decoupling

To achieve the best results when using the device, decouple the V<sub>DD</sub> and DVDD power supplies with a 0.1μF capacitor. Use a high-quality, ceramic, surface-mount capacitor if possible. Surface-mount components minimize lead inductance, which improves performance, and ceramic capacitors tend to have adequate high-frequency response for decoupling applications.

**Table 10. Decoding RTD Faults for 2-Wire Setups When Fault Bit in RTD Data LSB Register = 1**

FAULT STATUS BIT SET	DESCRIPTION OF POSSIBLE CAUSE	CONDITION DETECTED	DESCRIPTION OF RESULTING DATA
D7	Open RTD element	Measured resistance greater than High Fault Threshold value	Full scale
D6	Shorted RTD element RTDIN+ shorted low	Measured resistance less than Low Fault Threshold value	Near zero
D5	Open RTD	$V_{REFIN-} > 0.85 \times V_{BIAS}$	Full scale
	RTDIN+ shorted high		Indeterminate
	RTDIN- shorted high		Indeterminate
D4	RTDIN- shorted low	$V_{REFIN-} < 0.85 \times V_{BIAS}$ (FORCE- open)	Appear to be valid
D3	RTDIN- shorted low	$V_{RTDIN-} < 0.85 \times V_{BIAS}$ (FORCE- open)	Appear to be valid
	RTDIN+ shorted low		Near zero
D2	Overvoltage or undervoltage fault	Any protected input voltage $>V_{DD}$ or $<GND1$	Indeterminate

**Table 11. Decoding RTD Faults for 3-Wire Setups When Fault Bit in RTD Data LSB Register = 1**

FAULT STATUS BIT SET	DESCRIPTION OF POSSIBLE CAUSE	CONDITION DETECTED	DESCRIPTION OF RESULTING DATA
D7	Open RTD element	Measured resistance greater than High Fault Threshold value	Full scale
	RTDIN+ shorted high and not connected to RTD		
	Force+ shorted high and connected to RTD		
D6	RTDIN+ shorted to RTDIN-	Measured resistance less than Low Fault Threshold value	Near zero
	RTDIN+ shorted low and not connected to RTD		
	Force+ shorted low		
D5	Open RTD element	$V_{REFIN-} > 0.85 \times V_{BIAS}$	Full scale
	Force+ shorted high and connected to RTD		
	Force+ unconnected		Indeterminate
	Force+ shorted high and not connected to RTD		
	RTDIN- shorted high		
D4	RTDIN- shorted low	$V_{REFIN-} < 0.85 \times V_{BIAS}$ (FORCE- open)	Appear to be valid
D3	Force+ shorted low	$V_{RTDIN-} < 0.85 \times V_{BIAS}$ (FORCE- open)	Near zero
	RTDIN+ shorted low and connected to RTD		
	RTDIN- shorted low		Appear to be valid
D2	Overvoltage or undervoltage fault	Any protected input voltage $>V_{DD}$ or $<GND1$	Indeterminate

**Table 12. Decoding RTD Faults for 4-Wire Setups When Fault Bit in RTD Data LSB Register = 1**

FAULT STATUS BIT SET	DESCRIPTION OF POSSIBLE CAUSE	CONDITION DETECTED	DESCRIPTION OF RESULTING DATA
D7	Open RTD element	Measured resistance greater than High Fault Threshold value	Full scale
	RTDIN+ shorted high and not connected to RTD		
	Force+ shorted high and connected to RTD		
D6	RTDIN+ shorted to RTDIN-	Measured resistance less than Low Fault Threshold value	Near zero
	RTDIN+ shorted low and not connected to RTD		
	RTDIN- shorted high and not connected to RTD		
	Force+ shorted low		
D5	Open RTD element	$V_{REFIN^-} > 0.85 \times V_{BIAS}$	Full scale
	Force+ shorted high and connected to RTD		
	Force- unconnected		
	Force+ unconnected		
	Force+ shorted high and not connected to RTD		Indeterminate
	Force- shorted high and not connected to RTD		
	Force- shorted high and connected to RTD		
	Force- shorted low and not connected to RTD		
D4	Force- shorted low and connected to RTD	$V_{REFIN^-} < 0.85 \times V_{BIAS}$ (FORCE- open)	Indeterminate
	RTDIN- shorted low and connected to RTD		Appear to be valid
D3	Force+ shorted low	$V_{RTDIN^-} < 0.85 \times V_{BIAS}$ (FORCE- open)	Near zero
	RTDIN+ shorted low and connected to RTD		
	RTDIN- shorted low and connected to RTD		Appear to be valid
	RTDIN- shorted low and not connected to RTD		
	Force- shorted low		
D2	Overvoltage or undervoltage fault	Any protected input voltage $>V_{DD}$ or $<GND1$	Indeterminate

Typical Application Circuits (continued)

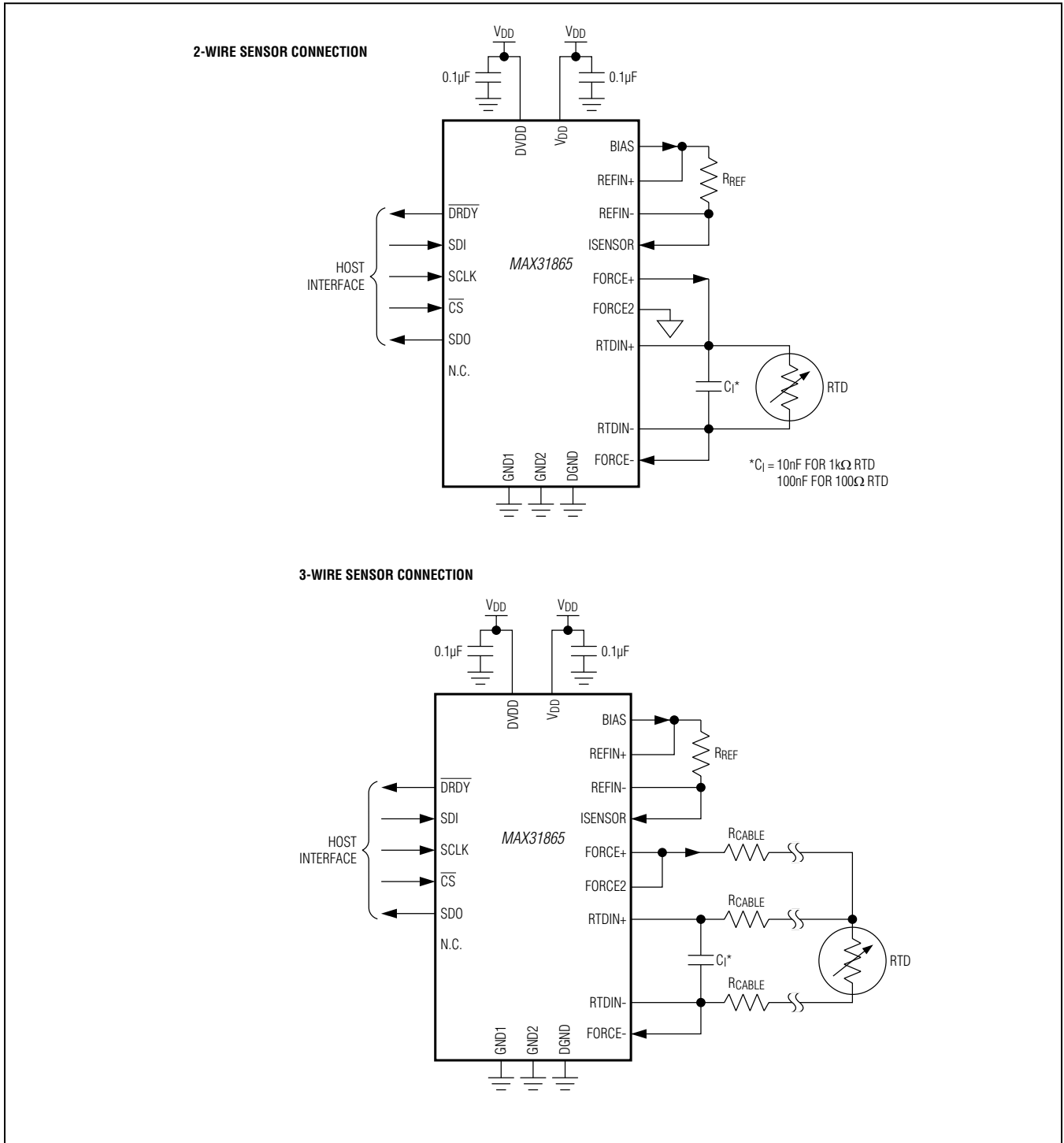

## Ordering Information

PART	TEMP RANGE	PIN-PACKAGE
MAX31865AAP+	-40°C to +125°C	20 SSOP
MAX31865AAP+T	-40°C to +125°C	20 SSOP
MAX31865ATP+	-40°C to +125°C	20 TQFN-EP*
MAX31865ATP+T	-40°C to +125°C	20 TQFN-EP*

+Denotes a lead(Pb)-free/RoHS-compliant package.

T = Tape and reel.

\*EP = Exposed pad.

## Package Information

For the latest package outline information and land patterns (footprints), go to [www.maximintegrated.com/packages](http://www.maximintegrated.com/packages). Note that a "+", "#", or "-" in the package code indicates RoHS status only. Package drawings may show a different suffix character, but the drawing pertains to the package regardless of RoHS status.

PACKAGE TYPE	PACKAGE CODE	OUTLINE NO.	LAND PATTERN NO.
20 TQFN-EP	T2055+5	<a href="#">21-0140</a>	<a href="#">90-0010</a>
20 SSOP	A20+1	<a href="#">21-0056</a>	<a href="#">90-0094</a>

## Revision History

REVISION NUMBER	REVISION DATE	DESCRIPTION	PAGES CHANGED
0	10/12	Initial release	—
1	1/15	Revised <i>Benefits and Features</i> section	1
2	5/15	Added the SSOP package to the data sheet and updated input voltage protection as $\pm 45V$ .	1, 2, 7, 10, 11, 24
3	7/15	Updated Table 6	16

For pricing, delivery, and ordering information, please contact Maxim Direct at 1-888-629-4642, or visit Maxim Integrated's website at [www.maximintegrated.com](http://www.maximintegrated.com).

*Maxim Integrated cannot assume responsibility for use of any circuitry other than circuitry entirely embodied in a Maxim Integrated product. No circuit patent licenses are implied. Maxim Integrated reserves the right to change the circuitry and specifications without notice at any time. The parametric values (min and max limits) shown in the Electrical Characteristics table are guaranteed. Other parametric values quoted in this data sheet are provided for guidance.*

## Looking for pricing, stock, or lifecycle information?

Click below to explore more details on WIN SOURCE:

 [View MAX31865AAP+](#) on WIN SOURCE

 [Maxim Integrated](#) Information

## Optimize Your Supply Chain with WIN SOURCE Solutions

-  Global Sourcing Solution
-  Obsolete Management
-  Cost Control Management
-  Shortage Management
-  Alternative Solution
-  Excess Inventory Management