



**THE DATASHEET OF
PMA3-63GLN+**





LOW NOISE, HIGH GAIN

Monolithic Amplifier

PMA3-63GLN+

50Ω 1.8 to 6.0 GHz

THE BIG DEAL

- Flat gain over wideband
- Low noise figure, 0.6 dB typ.
- High gain, up to 29.7 dB typ.
- High IP3, +28.6 dBm typ.
- Excellent gain flatness, ±1.6 dB over 2.5 to 6 GHz
- Low Additive Phase Noise

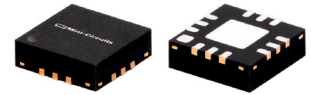

Generic photo used for illustration purposes only

CASE STYLE: DQ1225

+RoHS Compliant

The +Suffix identifies RoHS Compliance. See our website for methodologies and qualifications

APPLICATIONS

- 5G
- WiFi
- WLAN
- UMTS
- LTE
- WiMAX
- S-band Radar
- C-band Satcom

PRODUCT OVERVIEW

The PMA3-63GLN+ is a PHEMT based wideband, low noise MMIC amplifier with a unique combination of low noise, high IP3, and flat gain over wideband making it ideal for sensitive, high-dynamic-range S-band receiver applications. This design operates on a single +5 V supply, is well matched for 50Ω and comes in a tiny, low profile package (3 x 3 x 0.89mm), accommodating dense circuit board layouts.

KEY FEATURES

Feature	Advantages
Low noise, 0.6 dB at 2.5 GHz	Enables lower system noise figure performance.
Wide bandwidth with flat gain • ±1.6 dB over 2.5 to 5 GHz	Enables a single amplifier to be used in many wideband applications including defense, instrumentation and more.
High Gain, 29.7 dB at 2.5 GHz	Enables signal amplification without the need for multiple gain stage. Thus minimize effect of subsequent stages on noise figure.
High IP3 • +28.6 dBm at 2.5 GHz	Combination of low noise and high IP3 makes this MMIC amplifier ideal for use in low noise receiver front end (RFE) as it gives the user advantages of sensitivity and two-tone IM performance at both ends of the dynamic range.
3 x 3mm 12-lead MCLP package	Tiny footprint saves space in dense layouts while providing low inductance, repeatable transitions, and excellent thermal contact to the PCB.

REV. B
ECO-010881
PMA3-63GLN+
RS/CP/AM
240401





LOW NOISE, HIGH GAIN

Monolithic Amplifier

PMA3-63GLN+

50Ω 1.8 to 6.0 GHz

ELECTRICAL SPECIFICATIONS¹ AT +25°C AND +5 V, UNLESS NOTED OTHERWISE

Parameter	Condition (GHz)	V _{DD} = +5 V			Units
		Min.	Typ.	Max.	
Frequency Range		1.8		6.0	GHz
Noise Figure	1.8		0.8		dB
	2.5		0.6		
	3.5		0.7	1.5	
	5		0.9		
	6		1.1		
Gain	1.8	28.5	31.7	34.8	dB
	2.5		29.7		
	3.5	25	27.9	30.6	
	5		26.5		
	6	22	24.9	26.9	
Input Return Loss	1.8		7		dB
	2.5		10		
	3.5		11		
	5		10		
	6		12		
Output Return Loss	1.8		10		dB
	2.5		10		
	3.5		10		
	5		16		
	6		22		
Output Power at 1dB Compression	1.8		+15.2		dBm
	2.5		+14.8		
	3.5	+12.4	+14.1		
	5		+11.5		
	6		+10.7		
Output IP3	1.8		+28.8		dBm
	2.5		+28.6		
	3.5	+22.1	+26.6		
	5		+23.4		
	6		+22.3		
Device Operating Voltage (V _{DD})			5.0		V
Device Operating Current (I _{DD})		-	69	80	mA
Device Current Variation vs. Temperature ²			-26.9		μA/°C
Device Current Variation vs. Voltage			0.006		mA/mV
Thermal Resistance, junction-to-ground lead			57.3		°C/W

1. Measured on Mini-Circuits Characterization test board TB-PMA3-63GLN+ with tested board loss being deducted. See Characterization Test Circuit (Fig. 1)
 2. (Current at 85°C - Current at -45°C)/130

ABSOLUTE MAXIMUM RATINGS³

Parameter	Ratings
Operating Temperature (ground lead)	-40°C to +85°C
Storage Temperature	-65°C to +150°C
Junction Temperature	+150°C
Total Power Dissipation	1.0 W
Input Power (CW), V _d =5V	+29 dBm (5 minutes max.) +10 dBm (continuous)
DC Voltage	+8.5 V

3. Permanent damage may occur if any of these limits are exceeded. Electrical maximum ratings are not intended for continuous normal operation.





LOW NOISE, HIGH GAIN

Monolithic Amplifier

PMA3-63GLN+

50Ω 1.8 to 6.0 GHz

SIMPLIFIED SCHEMATIC & PAD DESCRIPTION

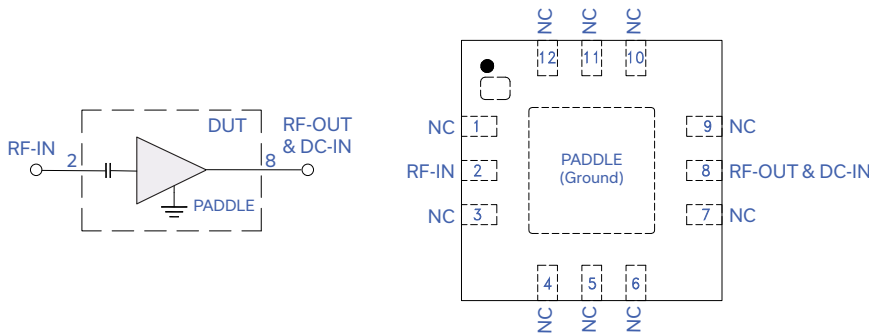

Function	Pad Number	Description (Fig. 1)
RF-IN	2	Connects to RF input via C1
RF-OUT & DC-IN	8	Connects to RF output via C2 and V_{DD} via L1
Ground	Paddle	Connects to ground
No Connection	1, 3 to 7, 9 to 12	Not used internally. Connected to ground on test board

RECOMMENDED APPLICATION AND CHARACTERIZATION TEST CIRCUIT

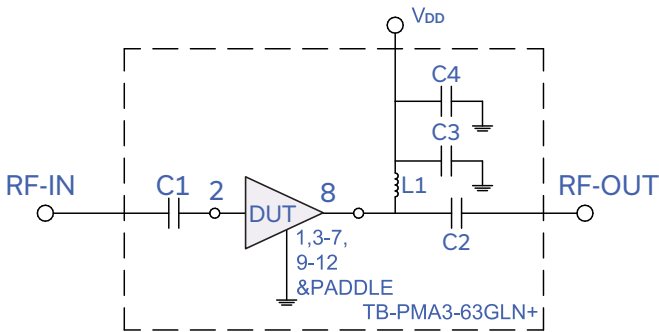

Fig 1. Application and Characterization Circuit

Note: This block diagram is used for characterization. (DUT soldered on Mini-Circuits Characterization test board TB-PMA3-63GLN+) Gain, Return loss, Output power at 1dB compression (P1 dB), output IP3 (OIP3) and noise figure measured using Agilent's N5242A PNA-X microwave network analyzer.

Conditions:

- Gain and Return Loss: $P_{IN} = -35\text{dBm}$
- Output IP3 (OIP3): Two tones, spaced 1 MHz apart, 0 dBm/tone at output.

Component	Size	Value	P/N	Manufacturer
C1	0402	22pF	GRM1555C1H220JA01	Murata
C2	0402	22pF	GRM1555C1H220JA01	Murata
C3	0402	100pF	GRM1555C1H101JA01	Murata
C4	1206	22uF	GRM31CR61H106KA12	Murata
L1	0402	10nH	LQG15HSIONJD2	Murata

PRODUCT MARKING

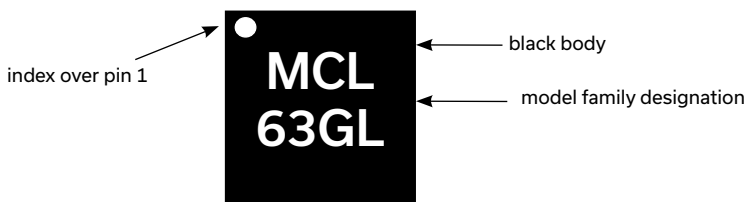

Marking may contain other features or characters for internal lot control





LOW NOISE, HIGH GAIN

Monolithic Amplifier

PMA3-63GLN+

50Ω 1.8 to 6.0 GHz

ADDITIONAL DETAILED TECHNICAL INFORMATION IS AVAILABLE ON OUR DASH BOARD. TO ACCESS [CLICK HERE](#)

Performance Data	Data Table
	Swept Graphs
	S-Parameter (S2P Files) Data Set (.zip file)
Case Style	DQ1225 Plastic package, exposed paddle, lead finish: Matte Tin
Tape & Reel	F66
Standard quantities available on reel	7" reels with 20, 50, 100, 200, 500, 1K, 2K or 3K devices
Suggested Layout for PCB Design	PL-611
Evaluation Board	TB-PMA3-63GLN+
Environmental Ratings	ENV08T1

ESD RATING

Human Body Model (HBM): Class 1C (1000 to <2000V) in accordance with ANSI/ESD STM 5.1 - 2001

MSL TEST FLOW CHART

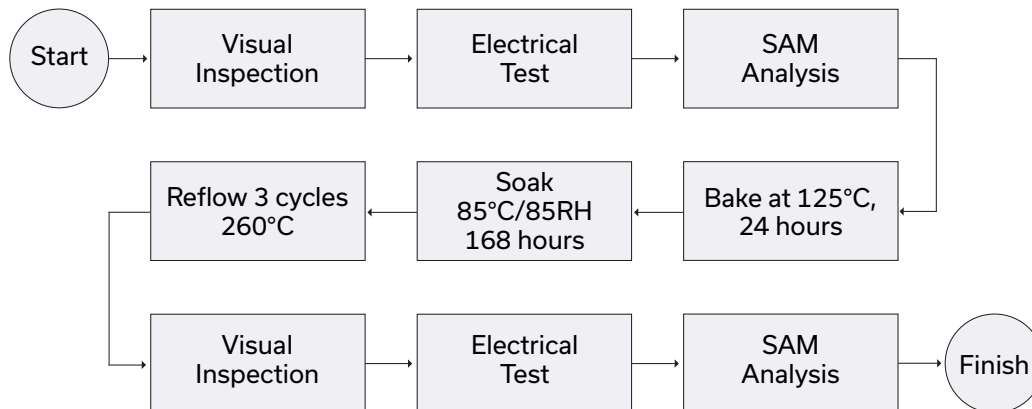



- NOTES**
- A. Performance and quality attributes and conditions not expressly stated in this specification document are intended to be excluded and do not form a part of this specification document.
 - B. Electrical specifications and performance data contained in this specification document are based on Mini-Circuit's applicable established test performance criteria and measurement instructions.
 - C. The parts covered by this specification document are subject to Mini-Circuits standard limited warranty and terms and conditions (collectively, "Standard Terms"); Purchasers of this part are entitled to the rights and benefits contained therein. For a full statement of the standard. Terms and the exclusive rights and remedies thereunder, please visit Mini-Circuits' website at www.minicircuits.com/MCLStore/terms.jsp



Looking for pricing, stock, or lifecycle information?

Click below to explore more details on WIN SOURCE:

-  [View PMA3-63GLN+ on WIN SOURCE](#)
-  [Mini-Circuits Information](#)

Optimize Your Supply Chain with WIN SOURCE Solutions

-  Global Sourcing Solution
-  Obsolete Management
-  Cost Control Management
-  Shortage Management
-  Alternative Solution
-  Excess Inventory Management