



**THE DATASHEET OF  
MASW-000936-14000T**



# PIN Diode SPDT 120 W Switch for 0.05 - 6 GHz High Power Applications



**MASW-000936**  
Rev. V8

## Features

- Exceptional Broadband Performance
- Low Insertion Loss:  $T_x = 0.20$  dB @ 2.7 GHz
- High Isolation:  $R_x = 50$  dB @ 2.7 GHz
- High  $T_x$  RF Input Power = 120 W CW @ 2.0 GHz, +85°C
- High  $T_x$  RF Input Peak Power: 1000 W
- Positive DC Bias Only Required
- Surface Mount 4 mm PQFN Package
- RoHS\* Compliant and 260°C Reflow Compatible

## Applications

- Suitable for High Power LTE, TD-SCDMA, WiMAX, and Military Radio Applications

## Description

The MASW-000936 is a SPDT high power, broadband, high linearity, PIN diode T/R switch for 0.05 - 6.0 GHz applications, including WiMAX & WiFi. The device is provided in an industry standard lead free 4 mm PQFN plastic package.

This device incorporates PIN diode die fabricated with a low loss, high isolation switching diode

## Ordering Information<sup>1</sup>

Part Number	Package
MASW-000936-14000T	1000 piece reel
MASW-000936-001SMB	Sample Board
MASW-000936-DRVSMB	Sample Board (with MADR-009150 driver)

1. Reference Application Note M513 for reel size information.

## Functional Diagram (Top View)

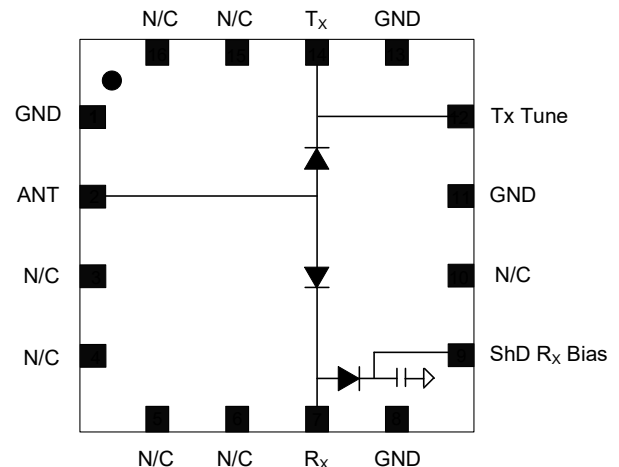

## Pin Configuration<sup>2</sup>

Pin #	Pin Name	Description
1,8,11,13	GND	Ground
2	ANT	Antenna
3,6,15	N/C	Connect to Ground
4,5,10,16	N/C	No Connection
7	R <sub>x</sub>	Receive
9	ShD R <sub>x</sub> Bias	ShD R <sub>x</sub> Bias
12	T <sub>x</sub> Tune	T <sub>x</sub> Tune <sup>3</sup>
14	T <sub>x</sub>	Transmit

2. The exposed pad centered on the package bottom must be connected to RF, DC and Thermal ground.
3. Optional tuning pin. See note 6 for details.

\* Restrictions on Hazardous Substances, compliant to current RoHS EU directive.

# PIN Diode SPDT 120 W Switch for 0.05 - 6 GHz High Power Applications



MASW-000936

Rev. V8

## Electrical Specifications<sup>4</sup>: Freq. = 2.0, 2.7, 3.5 GHz, T<sub>A</sub> = 25°C, Bias = 100 mA / 28 V

Parameter	Test Conditions	Units	Min.	Typ.	Max.	
Insertion Loss <sup>4</sup> P <sub>IN</sub> = 0 dBm	R <sub>X</sub> , 0.8 GHz	dB	—	0.20	—	
	T <sub>X</sub> , 0.8 GHz			0.07	—	
	R <sub>X</sub> , 2.0 GHz			0.35	0.55	
	T <sub>X</sub> , 2.0 GHz			0.15	—	
	R <sub>X</sub> , 2.7 GHz			0.50	0.75	
	T <sub>X</sub> , 2.7 GHz			0.20	—	
	R <sub>X</sub> , 3.5 GHz			0.70	0.90	
	T <sub>X</sub> , 3.5 GHz	0.25	—			
Isolation <sup>4</sup> P <sub>IN</sub> = 0 dBm	R <sub>X</sub> to Antenna, 2.0 GHz	dB	41	45	—	
	T <sub>X</sub> to Antenna, 2.0 GHz		—	16		
	R <sub>X</sub> to Antenna, 2.7 GHz		40	50		
	T <sub>X</sub> to Antenna, 2.7 GHz		—	13		
	R <sub>X</sub> to Antenna, 3.5 GHz		33	40		
	T <sub>X</sub> to Antenna, 3.5 GHz		—	11		
Input Return Loss <sup>4</sup> P <sub>IN</sub> = 0 dBm	R <sub>X</sub>	dB	—	23	—	
	T <sub>X</sub>			34		
T <sub>X</sub> Input P0.1 dB	T <sub>X</sub> to Antenna	dBm	—	>50	—	
T <sub>X</sub> IIP3 P <sub>IN</sub> = 30 dBm	F1 = 2010 MHz, F2 = 2020 MHz	dBm	—	72	—	
T <sub>X</sub> CW Input Power	85°C Base plate	dBm / W	—	50.8 / 120	—	
	2.0 GHz					
	2.7 GHz					50 / 100
	3.5 GHz					49 / 80
R <sub>X</sub> CW Input Power	85°C Base plate	dBm W	—	41.5	—	
	2.0 GHz					14
T <sub>X</sub> RF Switching Speed	(10 - 90% RF Voltage) 1 MHz Rep Rate in Modulating Mode	ns	—	200	—	

4. See Bias Table

# PIN Diode SPDT 120 W Switch for 0.05 - 6 GHz High Power Applications



MASW-000936  
Rev. V8

## Bias Schematic

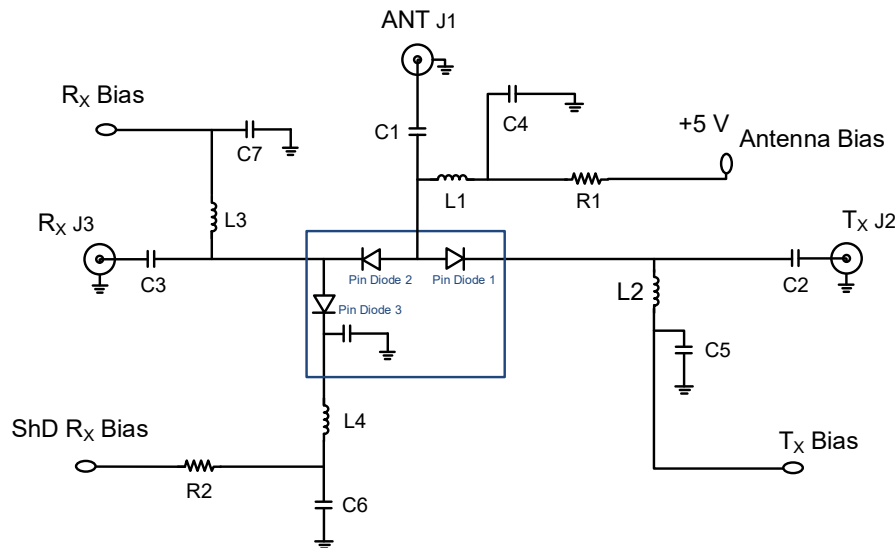

## Parts List<sup>6</sup>

Component	Value	Package
C1 - C3	22 pF	0603
C4 - C7	27 pF	0603
L1 - L4	68 nH	0603
R1 <sup>5</sup>	39 Ω	0603
R2 <sup>5</sup>	480 Ω	See note 5

## Suggested Switch Driver MADR-009150 or MADR-010574

- R1 and R2 values equal to  $((\text{Applied Bias Voltage}) - (\text{Forward Voltage of Diode})) / (I_{\text{bias}})$  where the Forward Voltage of Diode (V<sub>f</sub>) can be approximated as 1 V. The size of the package will depend on the power rating needed.
- Not shown, adding an LC network to pin 12 can improve R<sub>x</sub> performance between 2.0 and 2.7 GHz but may limit performance above 3.0 GHz. For broadband applications MACOM recommends not using pin 12 and not connecting it to any metal trace.

## Bias Table

Switch State	T <sub>x</sub> Bias	R <sub>x</sub> Bias	ShD R <sub>x</sub> Bias	ANT Bias
T <sub>x</sub> -ANT Isolation	(+28 V), 0 mA	(GND), -100 mA	(+28 V), 0 mA	+5 V
T <sub>x</sub> -ANT Insertion Loss	(GND), -100 mA	(+28 V), +56 mA	(GND), -56 mA	+5 V
R <sub>x</sub> -ANT Isolation	(GND), -100 mA	(+28 V), +56 mA	(GND), -56 mA	+5 V
R <sub>x</sub> -ANT Insertion Loss	(+28 V), 0 mA	(GND), -100 mA	(+28 V), 0 mA	+5 V

# PIN Diode SPDT 120 W Switch for 0.05 - 6 GHz High Power Applications



MASW-000936

Rev. V8

## Absolute Maximum Ratings<sup>7,8,9</sup>

@ T<sub>A</sub> = +25°C (unless otherwise specified)

Parameter	Absolute Maximum
Forward Current	150 mA
DC Reverse Voltage	130 V
T <sub>X</sub> Incident CW Power	See Power De-rating Curve
T <sub>X</sub> Incident Peak Power (10 μs Pulse Width <sup>10</sup> )	1000 W
R <sub>X</sub> Incident CW Power	41.5 dBm (14 W) @ 2 GHz, +85°C
Junction Temperature	+175°C
Operating Temperature	-40°C to +100°C
Storage Temperature	-55°C to +150°C

7. Exceeding these limits may cause permanent damage.
8. MACOM does not recommend sustained operation near these survivability limits.
9. Operating at nominal conditions with T<sub>J</sub> ≤ +175°C will ensure MTTF > 1 x 10<sup>6</sup> hours.
10. Measured with 4 ms pulse period, up to +100°C case temperature.

## Minimum Reverse Bias Voltage<sup>11</sup>

Frequency (MHz)	DC Voltage (V)
50	130 <sup>12</sup>
500	91 <sup>12</sup>
1000	57 <sup>12</sup>
2000	31
4000	16
6000	11

11. Minimum DC bias voltage to maintain low loss under 120 W of Tx power with 1.5:1 VSWR
12. The MADR-009150 switch driver has a maximum output voltage of 55 V. If a higher output voltage is desired, then one may want to consider using the MADR-010574 switch driver.

## T<sub>X</sub> Input Power De-rating @ 20 dB I/O Return Loss

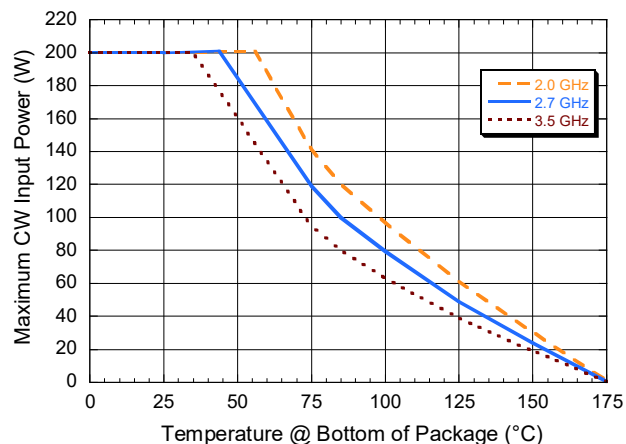

## Handling Procedures

Please observe the following precautions to avoid damage:

### Static Sensitivity

Silicon Integrated Circuits are sensitive to electrostatic discharge (ESD) and can be damaged by static electricity. Proper ESD control techniques should be used when handling these Class 1C Human Body devices.

# PIN Diode SPDT 120 W Switch for 0.05 - 6 GHz High Power Applications



MASW-000936  
Rev. V8

## Typical Performance Curves (RF-probed parts), $T_x$ (100 mA Bias Current)

**Insertion Loss,  $T_x$**

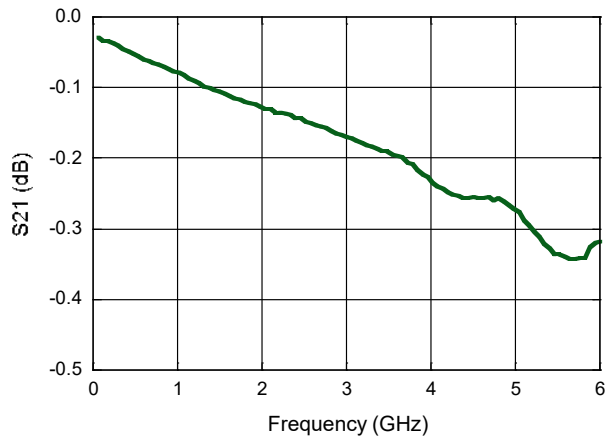

**Isolation,  $T_x$**

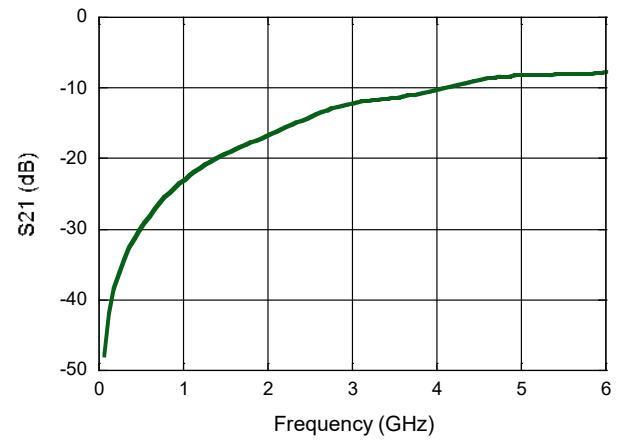

**Input Return Loss,  $T_x$**

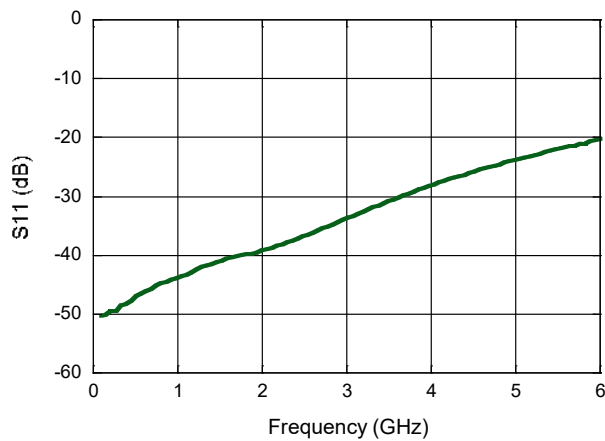

**Output Return Loss,  $T_x$**

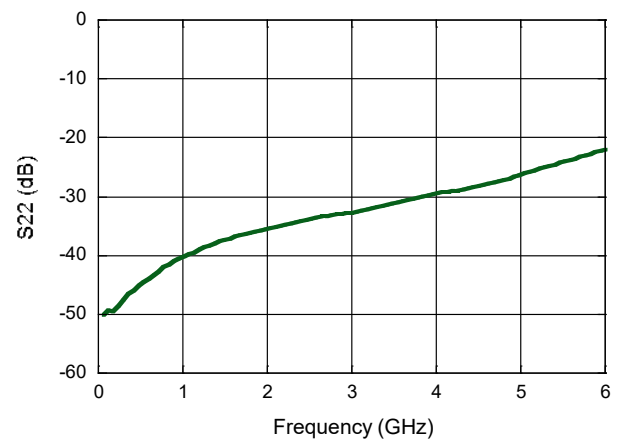

# PIN Diode SPDT 120 W Switch for 0.05 - 6 GHz High Power Applications



MASW-000936  
Rev. V8

## Typical Performance Curves (RF-probed parts), $R_X$ (100 mA Bias Current)

**Insertion Loss,  $R_X$**

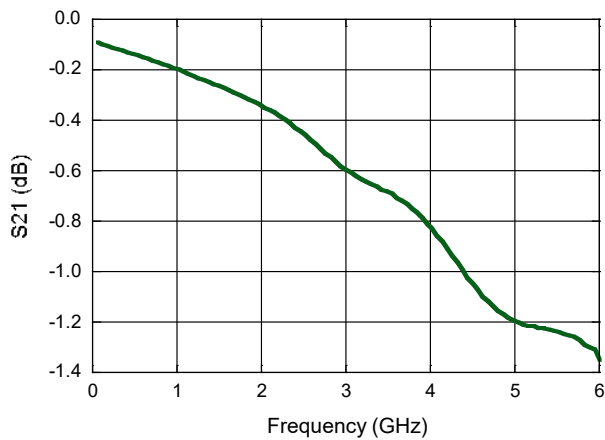

**Isolation,  $R_X$**

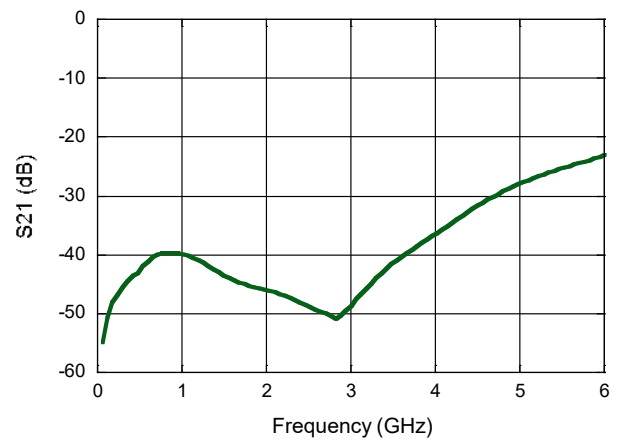

**Input Return Loss,  $R_X$**

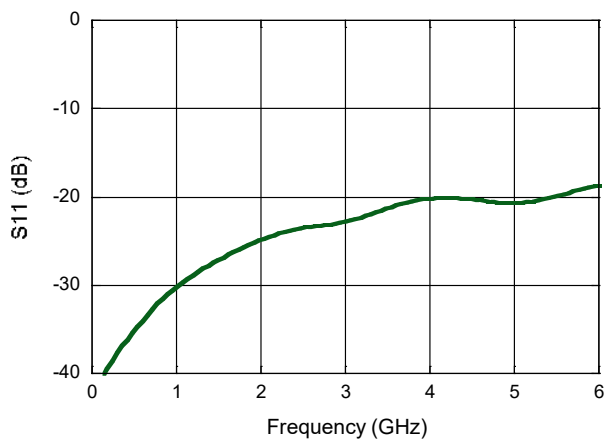

**Output Return Loss,  $R_X$**

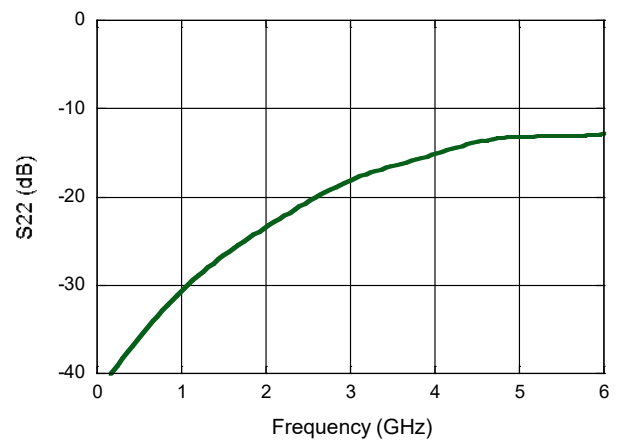

# PIN Diode SPDT 120 W Switch for 0.05 - 6 GHz High Power Applications



MASW-000936

Rev. V8

## PCB Footprint

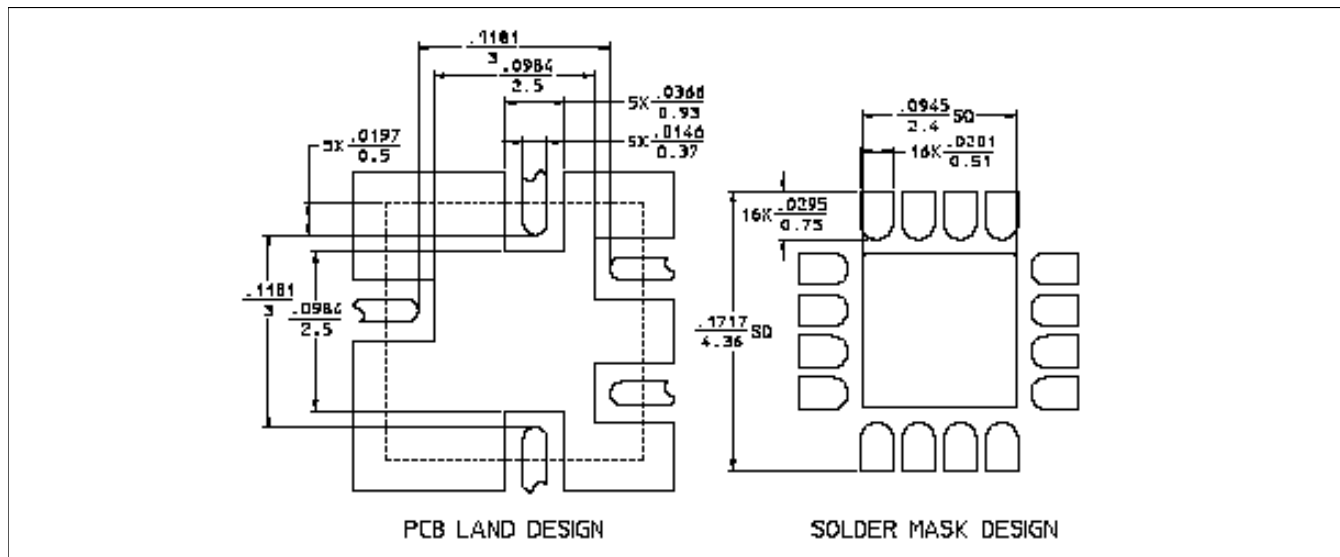

## Lead Free 4 mm 16-Lead PQFN<sup>†</sup>

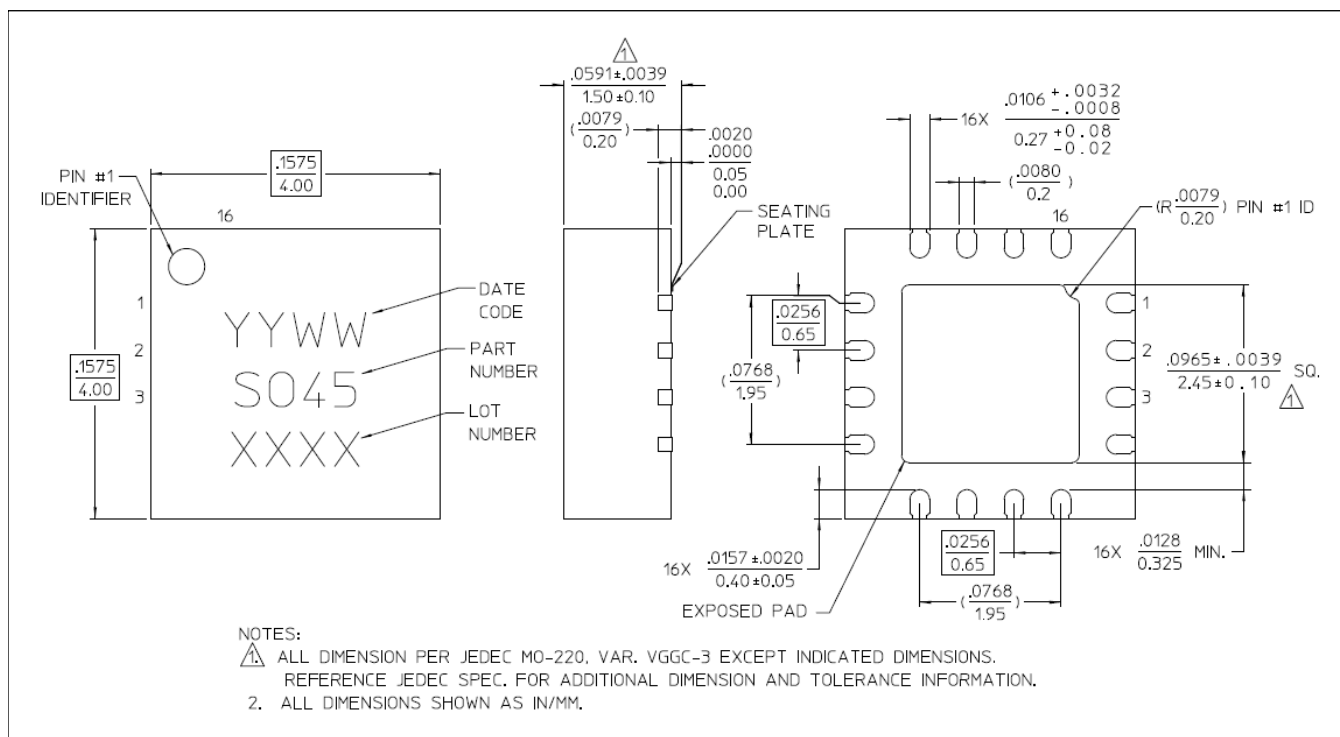

<sup>†</sup> Reference Application Note S2083 for lead-free solder reflow recommendations.  
 Meets JEDEC moisture sensitivity level (MSL) 1 requirements.  
 Plating is NiPdAuAg.

# PIN Diode SPDT 120 W Switch for 0.05 - 6 GHz High Power Applications



MASW-000936

Rev. V8

MACOM Technology Solutions Inc. ("MACOM"). All rights reserved.

These materials are provided in connection with MACOM's products as a service to its customers and may be used for informational purposes only. Except as provided in its Terms and Conditions of Sale or any separate agreement, MACOM assumes no liability or responsibility whatsoever, including for (i) errors or omissions in these materials; (ii) failure to update these materials; or (iii) conflicts or incompatibilities arising from future changes to specifications and product descriptions, which MACOM may make at any time, without notice. These materials grant no license, express or implied, to any intellectual property rights.

THESE MATERIALS ARE PROVIDED "AS IS" WITH NO WARRANTY OR LIABILITY, EXPRESS OR IMPLIED, RELATING TO SALE AND/OR USE OF MACOM PRODUCTS INCLUDING FITNESS FOR A PARTICULAR PURPOSE, MERCHANTABILITY, INFRINGEMENT OF INTELLECTUAL PROPERTY RIGHT, ACCURACY OR COMPLETENESS, OR SPECIAL, INDIRECT, INCIDENTAL, OR CONSEQUENTIAL DAMAGES WHICH MAY RESULT FROM USE OF THESE MATERIALS.

MACOM products are not intended for use in medical, lifesaving or life sustaining applications. MACOM customers using or selling MACOM products for use in such applications do so at their own risk and agree to fully indemnify MACOM for any damages resulting from such improper use or sale.

## Looking for pricing, stock, or lifecycle information?

Click below to explore more details on WIN SOURCE:

- ⊖ [View MASW-000936-14000T on WIN SOURCE](#)
- ⊖ [M/A-Com Technology Solutions Information](#)

## Optimize Your Supply Chain with WIN SOURCE Solutions

- ✓ Global Sourcing Solution
- ✓ Obsolete Management
- ✓ Cost Control Management
- ✓ Shortage Management
- ✓ Alternative Solution
- ✓ Excess Inventory Management